

FORD **EVEREST** Owner's Manual



Go Further

The information contained in this publication was correct at the time of going to print. In the interest of continuous development, we reserve the right to change specifications, design or equipment at any time without notice or obligation. No part of this publication may be reproduced, transmitted, stored in a retrieval system or translated into any language in any form by any means without our written permission. Errors and omissions excepted.

© Ford Motor Company 2015

All rights reserved.

Part Number: EB3B-19G219-YAB 20150930234803

Table of Contents

Introduction

About This Manual.....	5
Symbols Glossary.....	5
Replacement Parts Recommendation.....	7
Mobile Communications Equipment.....	8

At a Glance

At a Glance.....	9
------------------	---

Child Safety

Child Restraints.....	15
Selecting a Child Restraint System.....	15
Installing Child Restraints.....	16
Child Restraint Positioning.....	18
Child Safety Locks.....	19

Seatbelts

Principle of Operation.....	20
Fastening the Seatbelts.....	21
Seatbelt Height Adjustment.....	22
Seatbelt Reminder.....	22
Seatbelt Maintenance.....	23

Supplementary Restraints System

Principle of Operation.....	24
-----------------------------	----

Keys and Remote Controls

General Information on Radio Frequencies.....	26
Remote Control.....	26
Replacing a Lost Key or Remote Control.....	28

MyKey™

Principle of Operation.....	29
Creating a MyKey.....	30
Clearing All MyKeys.....	30

Checking MyKey System Status.....	32
MyKey Troubleshooting.....	33

Locks

Locking and Unlocking.....	34
Manual Liftgate.....	35
Power Liftgate.....	36

Security

Passive Anti-Theft System.....	39
Anti-Theft Alarm.....	39

Steering Wheel

Adjusting the Steering Wheel.....	41
Audio Control.....	41
Voice Control.....	42
Cruise Control.....	42
Information Display Control.....	42

Wipers and Washers

Windshield Wipers.....	43
Autowipers.....	43
Windshield Washers.....	44
Rear Window Wiper and Washers.....	45
Headlamp Washers.....	45

Lighting

General Information.....	46
Lighting Control.....	46
Autolamps.....	47
Automatic High Beam Control.....	47
Daytime Running Lamps.....	49
Front Fog Lamps.....	49
Rear Fog Lamps.....	49
Headlamp Leveling.....	50
Direction Indicators.....	51
Ambient Lighting.....	51
Interior Lamps.....	51

Table of Contents

Windows and Mirrors

Power Windows.....	53
Global Opening and Closing.....	55
Exterior Mirrors.....	56
Interior Mirror.....	57
Moonroof.....	57

Instrument Cluster

Gauges.....	59
Warning Lamps and Indicators.....	61
Audible Warnings and Indicators.....	65

Information Displays

General Information.....	67
Clock.....	74
Trip Computer.....	74
Personalized Settings.....	75
Information Messages.....	76

Climate Control

Principle of Operation.....	89
Air Vents.....	89
Manual Climate Control.....	90
Automatic Climate Control.....	92
Hints on Controlling the Interior Climate.....	95
Rear Passenger Climate Controls.....	98
Heated Windows and Mirrors.....	98
Cabin Air Filter.....	99

Seats

Sitting in the Correct Position.....	100
Head Restraints.....	100
Manual Seats.....	101
Power Seats.....	103
Rear Seats.....	104
Heated Seats.....	108

Auxiliary Power Points

Auxiliary Power Points.....	109
-----------------------------	-----

Storage Compartments

Cup Holders.....	111
Glove Box.....	111
Center Console.....	111
Overhead Console.....	112

Starting and Stopping the Engine

General Information.....	113
Ignition Switch.....	113
Steering Wheel Lock.....	113
Starting a Diesel Engine.....	114
Diesel Particulate Filter.....	114
Switching Off the Engine.....	115

Fuel and Refueling

Safety Precautions.....	116
Fuel Quality.....	116
Running Out of Fuel.....	117
Catalytic Converter.....	118
Selective Catalytic Reduction System.....	118
Refueling.....	122

Transmission

Automatic Transmission.....	124
Electronic Locking Differential.....	127

All-Wheel Drive

Using All-Wheel Drive.....	129
----------------------------	-----

Brakes

General Information.....	130
Hints on Driving With Anti-Lock Brakes.....	130
Parking Brake.....	130
Hill Start Assist.....	130

Table of Contents

Traction Control

Principle of Operation.....	133
Using Traction Control.....	133

Stability Control

Principle of Operation.....	134
Using Stability Control.....	135

Hill Descent Control

Principle of Operation.....	136
Using Hill Descent Control.....	136

Parking Aids

Principle of Operation.....	138
Rear Parking Aid.....	138
Front Parking Aid.....	139
Active Park Assist.....	140
Rear View Camera.....	144

Cruise Control

Principle of Operation.....	146
Using Cruise Control.....	146
Using Adaptive Cruise Control.....	147

Driving Aids

Speed Limiter.....	153
Driver Alert.....	153
Lane Keeping System.....	155
Blind Spot Information System.....	159
Steering.....	163
Pre-Collision Assist.....	164

Load Carrying

General Information.....	168
Roof Racks and Load Carriers.....	168

Towing

Towing a Trailer.....	169
Tow Ball.....	170

Trailer Sway Control.....	171
Recommended Towing Weights.....	171
Essential Towing Checks.....	173
Towing Points.....	175
Towing the Vehicle on Four Wheels.....	176

Driving Hints

Breaking-In.....	177
Reduced Engine Performance.....	177
Off-Road Driving.....	177
Cold Weather Precautions.....	182
Driving Through Water.....	182
Floor Mats.....	182

Roadside Emergencies

Hazard Warning Flashers.....	184
Jump Starting the Vehicle.....	184
Post-Crash Alert System.....	185
Transporting the Vehicle.....	186

Fuses

Fuse Box Locations.....	187
Changing a Fuse.....	188
Fuse Specification Chart - 3.2L Duratorq-TDCi (148kW/200PS) - Puma.....	189

Maintenance

General Information.....	201
Opening and Closing the Hood.....	201
Under Hood Overview - 3.2L Duratorq-TDCi (143kW/194PS) - Puma.....	203
Engine Oil Dipstick.....	205
Engine Oil Check.....	205
Engine Coolant Check.....	205
Brake and Clutch Fluid Check.....	207
Washer Fluid Check.....	207
Draining the Fuel Filter Water Trap.....	207
Changing the 12V Battery.....	208

Table of Contents

Checking the Wiper Blades.....	208
Changing the Wiper Blades.....	208
Removing a Headlamp.....	210
Changing a Bulb.....	210
Bulb Specification Chart.....	214
Changing the Engine Air Filter.....	216

Vehicle Care

Cleaning the Exterior.....	217
Cleaning the Interior.....	217

Wheels and Tires

General Information.....	219
Tire Care.....	219
Using Snow Chains.....	224
Tire Pressure Monitoring System.....	224
Changing a Road Wheel.....	228
Technical Specifications.....	233

Capacities and Specifications

Vehicle Dimensions.....	234
Vehicle Identification Plate.....	236
Vehicle Identification Number.....	237
Engine Number.....	237

Audio System

General Information.....	239
Audio Unit - Vehicles With: AM/FM/CD/ SYNC/DAB/Touchscreen Display.....	240
Audio Unit Clock and Date Displays.....	242
Compact Disc Player.....	242
Media Hub.....	246
Audio Troubleshooting.....	247

SYNC™

General Information.....	248
Using Voice Recognition.....	249
Using SYNC™ With Your Phone.....	252
SYNC™ Applications and Services.....	263

Using SYNC™ With Your Media Player.....	270
SYNC™ Troubleshooting.....	276

SYNC™ 2

General Information.....	286
Settings.....	295
Entertainment.....	309
Phone.....	318
Information.....	326
Climate.....	331
Navigation.....	334
SYNC™ Troubleshooting.....	343

Appendices

Electromagnetic Compatibility.....	351
Type Approvals.....	352
End User License Agreement.....	355
End User License Agreement.....	361

Introduction

ABOUT THIS MANUAL

Thank you for choosing Ford. We recommend that you take some time to get to know your vehicle by reading this manual. The more that you know about your vehicle, the greater the safety and pleasure you will get from driving it.

WARNING



Driving while distracted can result in loss of vehicle control, crash and injury. We strongly recommend that you use extreme caution when using any device that may take your focus off the road. Your primary responsibility is the safe operation of your vehicle. We recommend against the use of any hand-held device while driving and encourage the use of voice-operated systems when possible. Make sure you are aware of all applicable local laws that may affect the use of electronic devices while driving.

Note: This manual describes product features and options available throughout the range of available models, sometimes even before they are generally available. It may describe options not fitted to the vehicle you have purchased.

Note: Some of the illustrations in this manual may show features as used in different models, so they may appear different to you on your vehicle.

Note: Always use and operate your vehicle in line with all applicable laws and regulations.

Note: Pass on this manual when selling your vehicle. It is an integral part of your vehicle.

This manual may qualify the location of a component as left-hand side or right-hand side. The side is determined when facing forward in the seat.

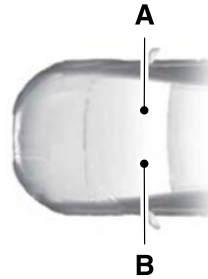

E154903

A Right-hand side.

B Left-hand side.

SYMBOLS GLOSSARY

These are some of the symbols you may see on your vehicle.



Safety alert



See Owner's Manual



Air conditioning system



Anti-lock braking system



Avoid smoking, flames or sparks



AdBlue[®] System



Battery



Battery acid

Introduction



Brake fluid - non petroleum based



Fasten seatbelt



Brake system



Front airbag



Cabin air filter



Front fog lamps



Check fuel cap



Fuse compartment



Child safety door lock or unlock



Hazard warning flashers



Child seat lower anchor



Heated rear window



Child seat tether anchor



Heated windshield



Cruise control



Interior luggage compartment release



Do not open when hot



Jack



Engine air filter



Lighting control



Engine coolant



Lock rear window



Engine coolant temperature



Low tire pressure warning



Engine oil



Maintain correct fluid level



Explosive gas



Panic alarm



Fan warning



Parking aid

Introduction



Parking brake



Power steering fluid



Power windows front/rear



Service engine soon



Side airbag



Stability control



Windshield wash and wipe



Keep out of reach of children



Recyclable product



Do not dispose of in the trash because the material contains lead



Use safety glasses when handling

REPLACEMENT PARTS RECOMMENDATION

Your vehicle has been built to the highest standards using quality parts. We recommend that you demand the use of genuine Ford and Motorcraft parts whenever your vehicle requires scheduled maintenance or repair. You can clearly identify genuine Ford and Motorcraft parts by looking for the Ford, FoMoCo or Motorcraft branding on the parts or their packaging.

Scheduled Maintenance and Mechanical Repairs

One of the best ways for you to make sure that your vehicle provides years of service is to have it maintained in line with our recommendations using parts that conform to the specifications detailed in this Owner's Manual. Genuine Ford and Motorcraft parts meet or exceed these specifications.

Collision Repairs

We hope that you never experience a collision, but accidents do happen. Genuine Ford replacement collision parts meet our stringent requirements for fit, finish, structural integrity, corrosion protection and dent resistance. During vehicle development we validate these parts deliver the intended level of protection as a whole system. A great way to know for sure you are getting this level of protection is to use genuine Ford replacement collision parts.

Introduction

Warranty on Replacement Parts

Genuine Ford and Motorcraft replacement parts are the only replacement parts that benefit from a Ford Warranty. Damage caused to your vehicle as a result of the failure of non-Ford parts may not be covered by the Ford Warranty. For additional information, refer to the terms and conditions of the Ford Warranty.

MOBILE COMMUNICATIONS EQUIPMENT

Using mobile communications equipment is becoming increasingly important in the conduct of business and personal affairs. However, you must not compromise your own or others' safety when using such equipment. Mobile communications can enhance personal safety and security when appropriately used, particularly in emergency situations. Safety must be paramount when using mobile communications equipment to avoid negating these benefits. Mobile communication equipment includes, but is not limited to, cellular phones, pagers, portable email devices, text messaging devices and portable two-way radios.

WARNING



Driving while distracted can result in loss of vehicle control, crash and injury. We strongly recommend that you use extreme caution when using any device that may take your focus off the road. Your primary responsibility is the safe operation of your vehicle. We recommend against the use of any hand-held device while driving and encourage the use of voice-operated systems when possible. Make sure you are aware of all applicable local laws that may affect the use of electronic devices while driving.

At a Glance

Front Exterior Overview

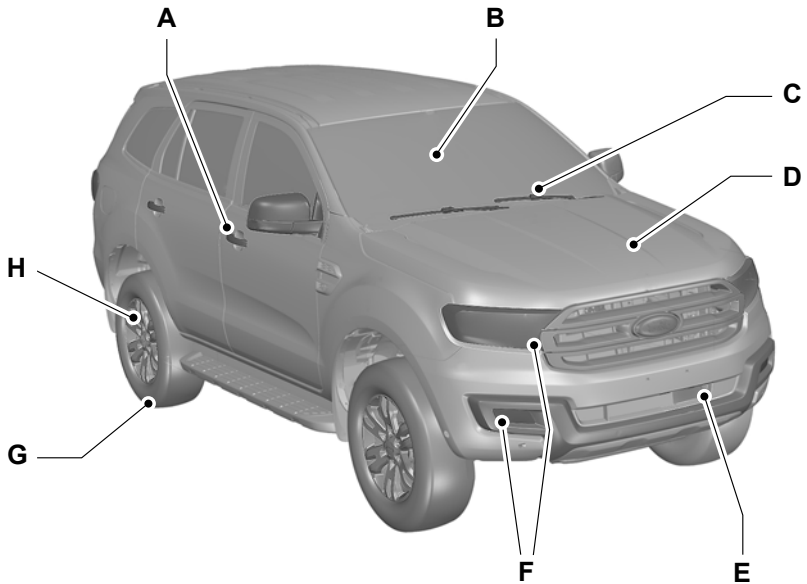

E194808

- A See **Locking and Unlocking** (page 34).
- B See **Interior Mirror** (page 57).
- C See **Changing the Wiper Blades** (page 208).
- D See **Under Hood Overview** (page 203).
- E See **Towing Points** (page 175).
- F See **Changing a Bulb** (page 210).

At a Glance

- G See **Technical Specifications** (page 233).
- H See **Changing a Road Wheel** (page 228).

Vehicle Interior Overview

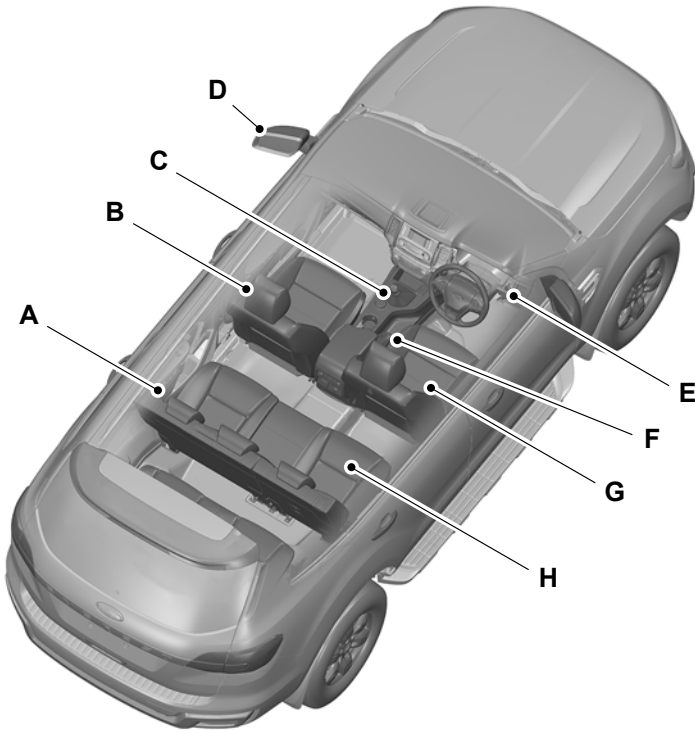

E194809

- A See **Fastening the Seatbelts** (page 21).
- B See **Head Restraints** (page 100).

At a Glance

- C See **Automatic Transmission** (page 124). See **Automatic Transmission** (page 124).
- D See **Exterior Mirrors** (page 56).
- E See **Opening and Closing the Hood** (page 201).
- F See **Parking Brake** (page 130).
- G See **Manual Seats** (page 101).
- H See **Rear Seats** (page 104).

Instrument Panel Overview

Left Hand Drive

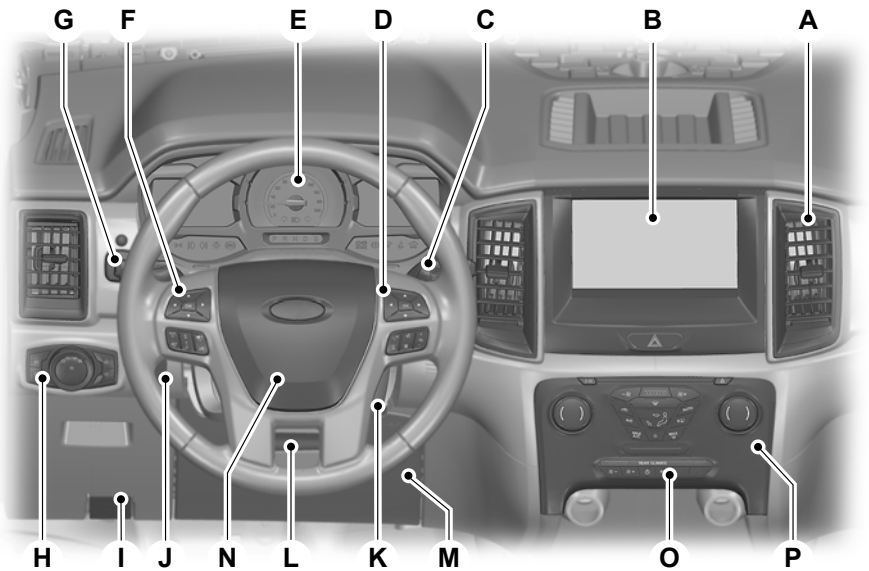

E196952

At a Glance

Right Hand Drive

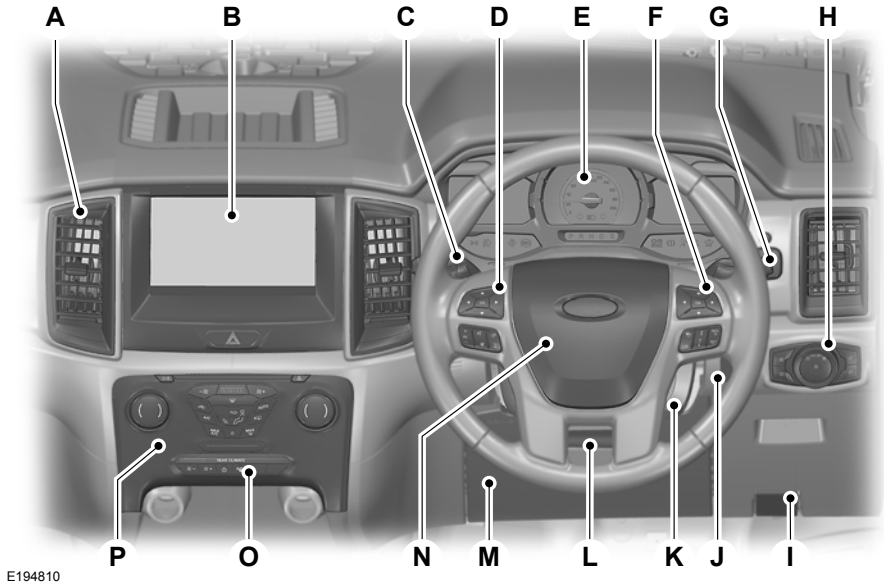

E194810

- A Air vents.
- B Multi-function display. See **General Information** (page 67).
- C Windshield wipers. See **Wipers and Washers** (page 43).
- D Audio control. See **Audio Control** (page 41).
- E Instrument cluster. See **Instrument Cluster** (page 59).
- F Cruise control buttons. See **Using Cruise Control** (page 146). Adaptive cruise control. See **Using Adaptive Cruise Control** (page 147).
- G Direction indicators. See **Direction Indicators** (page 51). Lane keeping system. See **Lane Keeping System** (page 155).
- H Lighting control. See **Lighting Control** (page 46).
- I Hood release lever. See **Fastening the Seatbelts** (page 21).
- J Power liftgate. See **Power Liftgate** (page 36).
- K Ignition switch. See **Ignition Switch** (page 113).

At a Glance

- L Steering wheel adjustment lever. See **Adjusting the Steering Wheel** (page 41).
- M Drivers knee airbag. See **Principle of Operation** (page 24).
- N Horn.
- O Climate control.
- P Audio unit. See **Audio System** (page 239).

Rear Exterior Overview

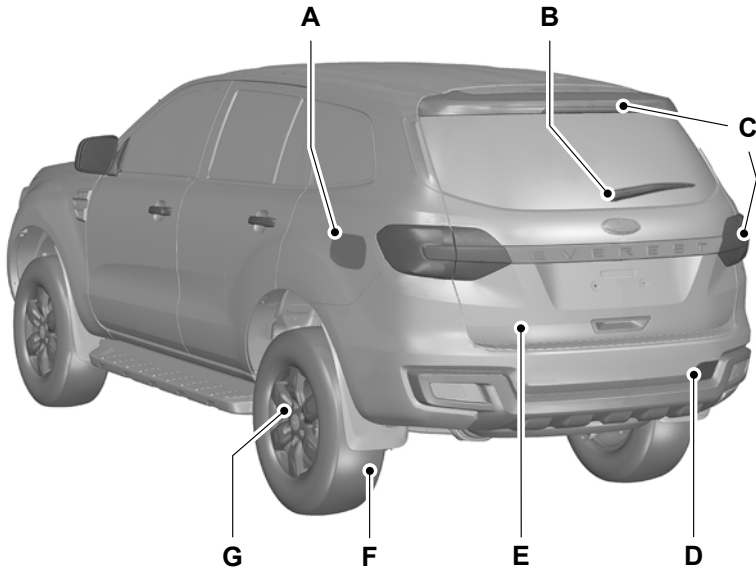

E194811

At a Glance

- A See **Refueling** (page 122).
- B See **Changing the Wiper Blades** (page 208).
- C See **Changing a Bulb** (page 210).
- D See **Towing Points** (page 175).
- E Spare wheel. Jack. See **Changing a Road Wheel** (page 228).
- F See **Technical Specifications** (page 233).
- G See **Changing a Road Wheel** (page 228).

Child Safety

CHILD RESTRAINTS

WARNINGS



Children must always be properly restrained.



This section provides useful information on the installation and safe use of child restraints. Ford strongly recommends that you read and understand this section before carrying children in your vehicle.

It is the driver's responsibility to ensure that the children are seated in suitable child restraints prescribed by the laws of the State or Territory in which the vehicle is operated.

If you are in any doubt about the laws that apply in your location, please consult your local Authorised Ford Dealer or Local Approved Child Restraint Fitting Station for assistance.

WARNING



EXTREME HAZARD! Do not use a rearward facing child restraint on a seat protected by an airbag in front of it.



E211048

WARNINGS



Seatbelts and seats can become hot in a vehicle that has been closed up in sunny weather, they could burn a small child. Check seat covers and buckles before you place a child anywhere near them.



Read and follow the child restraint manufacturer's instructions when you are fitting a child restraint.



Do not alter or modify child restraints in any way.



Do not hold a child on your lap when the vehicle is moving.



Do not leave children unattended in your vehicle.



On hot days, the temperature inside the vehicle can rise very quickly. Exposure of people or animals to these high temperatures for even a short time can cause death or serious heat related injuries, including brain damage. Small children are particularly at risk.



Destroy the child restraint if it has been in a severe crash, even if no damage is visible.

SELECTING A CHILD RESTRAINT SYSTEM



To provide protection, a child restraint system should meet three requirements.

Child Safety

1. **The child restraint system complies with Australian Standard AS1754.** Infants and children must be properly restrained at all times in an approved child restraint which conforms to Australian Standards AS1754 - 2004 or later. Look for the Australian Standard Approval Mark on the child restraint.
2. **The child restraint must be suitable for the size and weight of the child and must be properly fitted and adjusted.** Use the child restraint exactly as shown in the instructions provided with the child restraint. If you have any doubts, contact the child restraint manufacturer or consult an approved Restraint Fitting Station.
3. **The child restraint system should fit the vehicle seating position (or positions) where it will be used.** Due to variations in the design of child restraint systems, vehicle seats and seatbelts, all child restraint systems may not fit all seating positions. Before purchasing a child restraint system, it is recommended that the child restraint system is tested in the specific vehicle seating position (or positions) where it is intended to be used. If a previously purchased child restraint does not fit, you may need to purchase a different one that will fit.

INSTALLING CHILD RESTRAINTS

WARNINGS

-  **EXTREME HAZARD!** Do not use a rearward facing child restraint on a seat protected by an airbag in front of it.
-  Incorrectly fitted child restraints may swing, tip or come away causing death or injury.

WARNINGS

-  Do not use a child restraint if the tether strap falls into a split in the vehicle seat back or falls off the edge of the vehicle seat.

After installing a child restraint system, push and pull the system forward and back and from side to side to verify that it is secured.

Be sure to read and follow the instructions provided by the child restraint manufacturer. If you have any doubts contact the child restraint manufacturer or consult an approved Restraint Fitting Station. Your automobile club or local vehicle registration authority can provide location details of fitting stations.

When installing the child restraint attaching clip to the anchor fitting, raise the head restraint (where fitted) and pass the tether strap between the head restraint supports. This will prevent the tether strap from falling off the outboard edge of the seating positions.

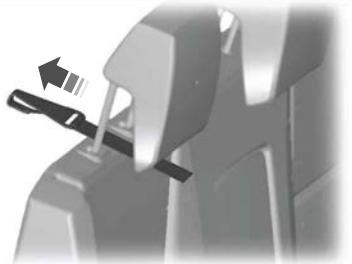

E166723

Note: Side curtain air bags (where fitted) will not interfere with a properly installed child restraint system or booster seat, because they are designed to inflate downward from the headliner above the doors along the side window openings.

Child Safety

When a child restraint system is not being used, either remove it and store it in a safe place, or make sure it is properly secured. An unsecured child restraint system can be thrown around the vehicle in a collision or sudden stop and injure someone.

CHILD RESTRAINT ANCHORAGE LOCATIONS

Upper (top tether) anchorages

WARNING



WARNING: child restraint anchorages are designed to withstand only those loads imposed by correctly fitted child restraints. Under no circumstances are they to be used for adult seatbelts, harnesses or for attaching other items or equipment to the vehicle.

Second Row Seats

There are three child restraint top tether anchorages on the second row seat backs, one for each rear seating position, located as shown in the following picture.

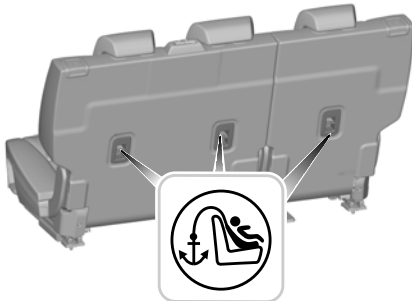

E213627

Third Row Seats

There are two child restraint top tether anchorages on the third row seat backs, one for each rear seating position, located as shown in the following picture.

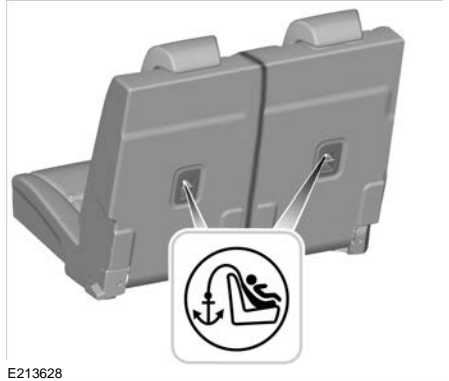

E213628

The top tether anchorages are only suitable for child restraints conforming to Australian Standard AS1754-2004 or later. If your child restraint does not have an approved latched hook attaching clip as shown, you should consult an approved restraint fitting station.

WARNINGS



Always ensure that the attaching clip is properly engaged with the anchor fitting and the tether strap length is adjusted to remove any slack.



Always ensure that the locking mechanism of the rear seat back is fully engaged when in the upright position, by attempting to pull it down again.



Do not attach a tether strap to anything other than the correct tether anchor point.



Make sure that the seat back is secure and fully engaged in the catch.

Child Safety

WARNINGS



Make sure that the tether strap tightening mechanism remains accessible when the seat back is fully engaged in the catch.

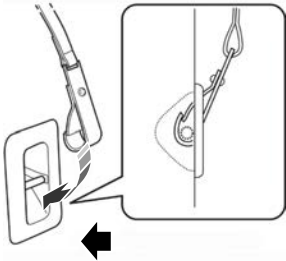

E166781

Note: Arrow points to front of vehicle.

Note: Where applicable, remove the luggage cover to ease installation.

Note: You may need to raise or remove the head restraint to ease installation. See **Head Restraints** (page 100).

ISOFIX LOWER ANCHORAGES (if Equipped)

WARNING



The ISOFIX lower anchorages must be used in conjunction with the upper (top tether) anchorages.

If your vehicle has ISOFIX lower anchorages they are located on the outboard rear seats, where the cushion and backrest meet.

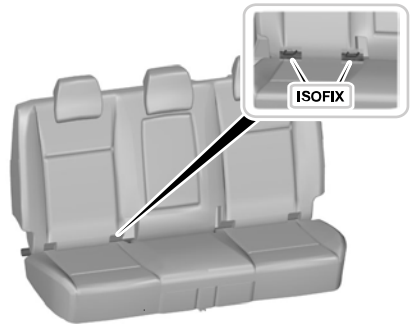

E132631

CHILD RESTRAINT POSITIONING

The rear seats (where provided) are the safest place for children.

When a child outgrows the recommended weight or height limits for a forward facing child restraint system, the child should sit on a booster seat and wear a lap-sash seatbelt. The raised seating position will allow you to position the shoulder strap of the adult seatbelt over the centre of your child's shoulder and the lap strap tightly across its hips. A booster seat should be used until the child is tall enough for the lap-sash seatbelt to fit properly.



Child Safety

Typical Booster Seat



E70710





WARNINGS

-  Do not install a booster seat with only the lap strap of the seatbelt.
-  Do not install a booster seat with a seatbelt that is slack or twisted.

CHECKING SEATBELT FIT

If the lap-sash seatbelt touches or crosses the child's neck, then the child needs a booster seat.

WARNINGS

-  Never wear a seatbelt across the neck. This could result in serious neck injury in the event of a collision.
-  Do not put the seatbelt under your child's arm or behind its back.
-  Do not use pillows, books or towels to boost your child's height.
-  Make sure that your children sit in an upright position.

CHILD SAFETY LOCKS

Manual Child Safety Locks

WARNING

-  You cannot open the doors from inside if you have put the child safety locks on.

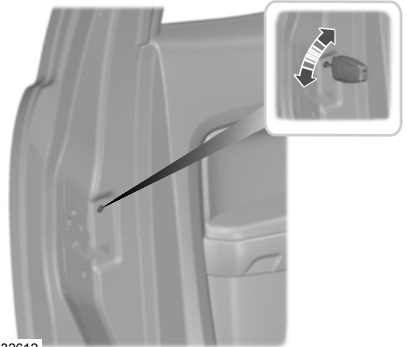

E132612

The childproof locks are located on the rear edge of each rear door and must be set separately for each door.

Left-Hand Side

Turn counterclockwise to lock and clockwise to unlock.

Right-Hand Side

Turn clockwise to lock and counterclockwise to unlock.

Seatbelts

PRINCIPLE OF OPERATION

WARNINGS

 The wearing of a seatbelt is a mandatory requirement. Seatbelts should be properly fastened and adjusted before the vehicle is driven. Adjust the driver's seat position before fastening the seatbelt.

 Seatbelts are designed to bear upon the bony structure of the body and should be worn low across the front of the pelvis or the pelvis, chest and shoulders, as applicable; wearing the lap section of the belt across the abdominal area must be avoided.

 Wear a seatbelt and keep sufficient distance between yourself and the steering wheel. Only when you use the seatbelt properly, can it hold you in position to achieve its optimum effect.

 Never use a seatbelt for more than one person; it is dangerous to put a belt around a child being carried on the occupant's lap.

 Use the correct buckle for each seatbelt.

 Do not use a seatbelt that is slack or twisted.

 Do not wear thick clothing. The seatbelt must fit tightly around your body to achieve its optimum effect.

 Position the shoulder strap of the seatbelt over the centre of your shoulder and position the lap strap tightly across your hips.

WARNINGS

 Care should be taken to avoid contamination of the webbing with polishes, oils and chemicals, and particularly battery acid. Cleaning may safely be carried out using mild soap and water. The belt should be replaced if the webbing becomes frayed, contaminated or damaged.

 No modifications or additions should be made by the user which will either prevent the seatbelt adjusting devices from operating to remove slack, or prevent the seatbelt assembly from being adjusted to remove slack.

 Seatbelts are designed to be used by adult sized occupants.

The driver and front passenger seatbelt systems are fitted with a seatbelt pretensioner. Seatbelt pretensioners have a lower deployment threshold than the airbags. During minor collisions, it is possible that only the seatbelt pretensioners will deploy.

Status after a collision

WARNINGS

 Seatbelts subjected to strain, as a result of an accident, should be renewed and the anchorages checked by a properly trained technician.

 If a seatbelt pretensioner has been deployed, the seatbelt must be renewed.

Seatbelts

The seatbelt pretensioners at the front seating positions are designed to tighten the seatbelts when activated. In frontal and near-frontal crashes, the seatbelt pretensioners may be activated alone or, if the crash is of sufficient severity, together with the front airbags. The pretensioners also activate when side airbags are deployed.

FASTENING THE SEATBELTS

WARNINGS



Insert the tongue into the buckle until you hear a distinct click. You have not fastened the seatbelt properly if you do not hear a click.



Make sure that the seatbelts are securely stowed away when not in use and are not outside your vehicle when closing the doors.



E74124

2nd Row seat

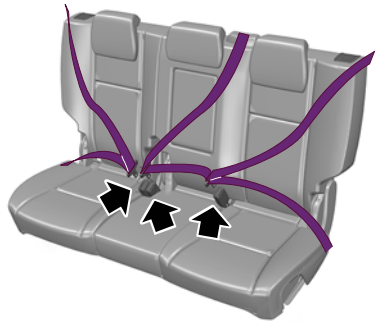

E200940

3rd Row seat

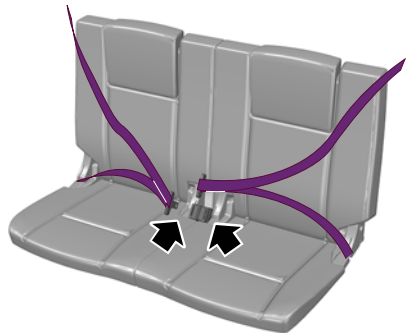

E200941

Pull the belt out steadily. It may lock if you pull it sharply or if your vehicle is on a slope.

Press the red button on the buckle to release the belt. Hold the tongue and let it retract completely and smoothly to its stowed position.

Seatbelts

The 2nd row centre seatbelt can lock if you return the seat back from a folded position to the upright position forcefully. Should the seatbelt lock, recline the seat using the recline adjustment. See **Rear Seats** (page 104).

Using Seatbelts During Pregnancy

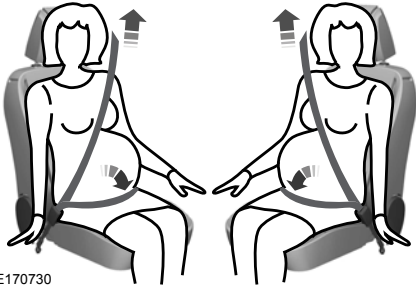

WARNING

 Position the seatbelt correctly for your safety and that of your unborn child. Do not use only the lap strap or the shoulder strap.

Pregnant women should always wear their seatbelt. The lap belt portion of a combination lap and shoulder belt should be positioned low across the hips below the belly and worn as tight as comfort will allow. The shoulder belt should be positioned to cross the middle of the shoulder and the centre of the chest.

SEATBELT HEIGHT ADJUSTMENT

WARNING

 Position the seatbelt height adjuster so that the seatbelt rests across the middle of your shoulder. Failure to adjust the seatbelt correctly could reduce its effectiveness and increase the risk of injury in a crash.

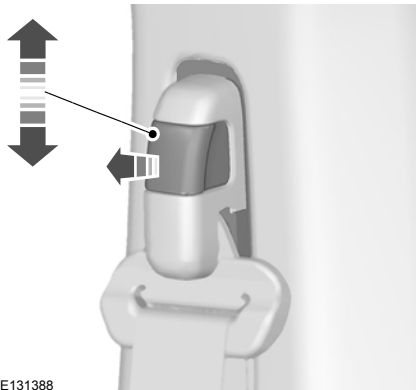

To adjust the shoulder belt height:

1. Pull the locking button and slide the height adjuster up or down.
2. Release the button and pull down on the height adjuster to make sure it is locked in place.

SEATBELT REMINDER

WARNING

 The system will only provide protection when you use the seatbelt correctly.

Seatbelts



Type 1: The seatbelt warning lamp will be illuminated for 6 seconds when the ignition is turned on to remind the driver to fasten the seatbelt.

Type 2: The seatbelt warning lamp will be illuminated at any time when the drivers seatbelt is not fastened.

Type 3: The seatbelt reminder warning lamp illuminates and an audible warning will sound if the driver or front passenger seatbelt has not been fastened and the vehicle exceeds a relatively low speed. It will also illuminate if either of the seatbelt is unfastened when the vehicle is moving. The audible warning will go off after five minutes but the seatbelt reminder warning lamp will remain on until the seatbelt is fastened.

Deactivating the seatbelt reminder

Contact an authorised dealer.

SEATBELT MAINTENANCE

Inspect the vehicle seatbelts periodically to make sure they work properly and are not damaged. Inspect the vehicle seatbelts to make sure there are no nicks, tears or cuts. Replace if necessary. All vehicle seatbelt assemblies, including retractors, buckles, front seatbelt buckle assemblies, buckle support assemblies (slide bar-if equipped), shoulder belt height adjusters (if equipped), shoulder belt guide on seat back (if equipped), should be inspected after a crash.

Ford Motor Company recommends that all seatbelt assemblies in use in vehicles involved in a crash be replaced. However, if the crash was minor and an authorized dealer finds that the belts do not show damage and continue to operate properly, they do not need to be replaced. Seatbelt assemblies not in use during a crash should also be inspected and replaced if either damage or improper operation is noted.

Properly care for seatbelts. See **Vehicle Care** (page 217).

Supplementary Restraints System

PRINCIPLE OF OPERATION

WARNINGS

 Do not fit a non-Ford approved bull bar or nudge-bar to your vehicle as this may interfere with the operation of the restraint system, including the air bag deployment, and could result in injury to yourself and others. Fitment of a non-Ford approved bull bar or nudge-bar may also void the vehicle's compliance with Australian Design Rules.

 Do not modify the front of your vehicle in any way. This could adversely affect deployment of the airbags. Failure to adhere to this warning could result in serious personal injury or death.

 Wear a seatbelt and keep sufficient distance between yourself and the steering wheel. Only when you use the seatbelt correctly, can it hold you in a position that allows the airbag to achieve its optimum effect. See **Principle of Operation** (page 24). Failure to adhere to this warning could result in serious personal injury or death.

 Repairs to the steering wheel, steering column, seats, airbags and seatbelts must be carried out by an authorized dealer. Failure to adhere to this warning could result in serious personal injury or death.

 Keep the areas in front of the airbags free from obstruction. Do not affix anything to or over the airbag covers. In the event of a crash, hard objects could cause serious personal injury or death.

 Do not puncture the seat with sharp objects. This could damage and adversely affect deployment of the airbags. Failure to adhere to this warning could result in serious personal injury or death.

WARNINGS

 Use seat covers designed for seats with side airbags. Have these fitted by an authorized dealer. Failure to adhere to this warning could result in serious personal injury or death.

Note: *You will hear a loud bang and see a cloud of harmless powdery residue if an airbag deploys. This is normal.*

Note: *Only wipe airbag covers with a damp cloth.*

DRIVER & FRONT PASSENGER AIRBAG

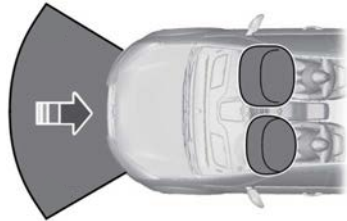

E151127

The driver and front passenger airbag will deploy during significant frontal or near-frontal collisions. The airbags will inflate within a few thousandths of a second and deflate on contact with the occupant, thus cushioning forward body movement. During minor frontal collisions, overturns, rear collisions and side collisions, the front passenger airbag will not deploy.

SIDE AIRBAGS

WARNING

 Use seat covers designed for seats with side airbags. Have these fitted by an authorized dealer.

Supplementary Restraints System



E72658

Side airbags are fitted inside the seat back of the front seats. A label indicates that side airbags are fitted to your vehicle.

The side airbags will deploy during significant lateral collisions. The airbags will inflate within a few thousandths of a second and deflate on contact with the occupants, thus providing protection for the chest and shoulder areas. During minor lateral collisions, overturns, front collisions and rear collisions, the side airbags will not deploy.

DRIVER KNEE AIRBAG

WARNING



Do not attempt to open the airbag cover.

The airbag will deploy during frontal collisions. The airbag will inflate within a few thousandths of a second and deflate on contact with the occupants, thus providing a cushion between the driver's knees and the steering column. During overturns, rear collisions and side collisions, the knee airbag will not deploy.

For item location: See **At a Glance** (page 9).

Note: The airbag has a lower deployment threshold than the front airbags. During a minor collision, it is possible that only the knee airbag will deploy.

SIDE CURTAIN AIRBAGS

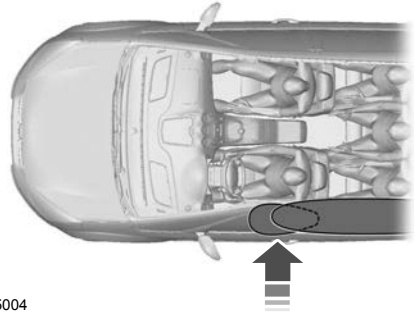

E75004

Curtain airbags are fitted inside the trim panels over the front and rear side windows. Moulded badges in the B-pillar trim panels indicate that curtain airbags are fitted to your vehicle.

The curtain airbags will deploy during significant lateral collisions. The airbag will inflate within a few thousandths of a second and deflate on contact with the occupants, thus providing protection for the head. During minor lateral collisions, front collisions, rear collisions, or overturns the curtain airbags will not deploy.

Keys and Remote Controls

GENERAL INFORMATION ON RADIO FREQUENCIES

Note: *Changes or modifications not expressly approved by the party responsible for compliance could void the user's authority to operate the equipment.*

The typical operating range for your transmitter is approximately 10 m.

A decrease in operating range could be caused by:

- weather conditions
- nearby radio towers
- structures around your vehicle
- other vehicles parked next to your vehicle.

The radio frequency used by your remote control can also be used by other radio transmitters, for example amateur radios, medical equipment, wireless headphones, wireless remote controls, cell phones, battery chargers and alarm systems. If the frequencies are jammed, you will not be able to use your remote control. You can lock and unlock the doors with the key.

Note: *Make sure your vehicle is locked before leaving it unattended.*

Note: *If you are in range, the remote control will operate if you press any button unintentionally.*

Note: *The remote control contains sensitive electrical components. Exposure to moisture or impact may cause permanent damage.*

REMOTE CONTROL

Reprogramming the Unlocking Function

Note: *When you press the unlock button either all the doors are unlocked or only the driver's door and the liftgate are unlocked. Pressing the unlock button again unlocks all the doors.*

Press and hold the unlock and lock buttons on the remote control simultaneously for at least four seconds with the ignition off. The direction indicators will flash twice to confirm the change.

To return to the original unlocking function, repeat the process.

Programming the additional key

Note: *You need to have two programmed keys for this procedure.*

1. Insert the first key and turn the ignition on.
2. Remove the key within 10 seconds.
3. Insert the second key within 10 seconds and turn the ignition on.
4. Remove the key within 10 seconds.
5. Insert the additional key within 10 seconds which need to be programmed.

Changing the Remote Control Battery



Make sure that you dispose of old batteries in an environmentally friendly way. Seek advice from your local authority regarding recycling.

Keys and Remote Controls

Remote Control With a Folding Key Blade

The remote control uses one coin-type three-volt lithium battery CR2032 or equivalent.



E168254

Press the button to release the key before beginning the procedure.



E168255

1. Insert a screwdriver in the position shown and gently push the clip.
2. Press the clip down to release the battery cover.

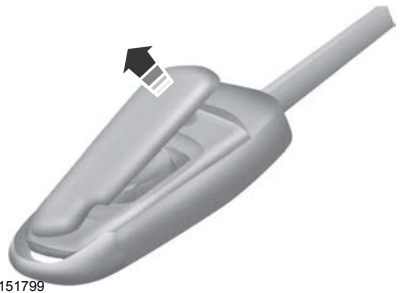

E151799

3. Carefully remove the cover.



E151800

Note: Do not touch the battery contacts or the printed circuit board with the screwdriver.

4. Insert a screwdriver as shown to release the battery.



E151801

5. Remove the battery.

Keys and Remote Controls

6. Install a new battery with the + facing up.
7. Replace the battery cover.

REPLACING A LOST KEY OR REMOTE CONTROL

Replacement keys or remote controls can be purchased from an authorized dealer. Authorized dealers can program remote controls for your vehicle. See **Passive Anti-Theft System** (page 39).

PRINCIPLE OF OPERATION

MyKey allows you to program keys with restricted driving modes to promote good driving habits. All but one of the keys can be activated with these restricted modes.

Any keys that remain unprogrammed are referred to as administrator keys or admin keys. They can be used to:

- Create a MyKey.
- Program configurable MyKey settings.
- Clear all MyKey features.

When you have created a MyKey, you can access the following information by using the information display to determine:

- How many admin keys and MyKeys are programmed to your vehicle.
- The total distance your vehicle traveled with a MyKey.

Note: *Switch the vehicle on to use the system.*

Note: *All MyKeys are programmed to the same settings. You cannot program them individually.*

Non-configurable Settings

The following settings cannot be changed by an MyKey key user:

- Seatbelt reminder. You cannot disable this feature. The audio system will mute when the front seat passengers' seatbelts are not fastened.
- Early low fuel or charge. The low-fuel or low charge warning activates earlier, giving the MyKey user more time to refuel or recharge.
- Driver assist features are forced on: parking aid and Blind Spot Information System (BLIS) with cross traffic alert.
- Satellite radio adult content restrictions.

Configurable Settings

With an admin key, you can configure certain MyKey settings when you first create a MyKey and before you recycle the key or restart the vehicle. You can also change the settings afterward with an MyKey key.

- A vehicle speed limit can be set. Warnings will be shown in the display followed by an audible tone when your vehicle reaches the set speed. You cannot override the set speed by fully depressing the accelerator pedal or by setting cruise control.

WARNING



Do not set MyKey maximum speed limit to a limit that will prevent the driver from maintaining a safe speed considering posted speed limits and prevailing road conditions. The driver is always responsible to drive in accordance with local laws and prevailing conditions. Failure to do so could result in accident or injury.

- Various vehicle speed minders can be set. Once you select a speed, it will be shown in the display, followed by an audible tone when the preselected vehicle speed is exceeded.
- Audio system maximum volume of 45%. A message will be shown in the display when you attempt to exceed the limited volume. Also, the speed-sensitive or compensated automatic volume control will be disabled.
- Always on setting. When this is selected, you will not be able to switch off AdvanceTrac™ or traction control, 911 Assist or Emergency Assistance, or the do not disturb feature.

CREATING A MYKEY

Use the information display to create a MyKey:

1. Insert the key you want to program into the ignition.

2. Switch the ignition on.
3. Access the main menu on the information display controls. Use the arrow keys to get to the following menu selections:

Message	Action and Description
Settings	Press the OK button or the right arrow key.
MyKey	Press the OK button or the right arrow key.
Create MyKey	Press the OK button or the right arrow key.

When prompted, hold the **OK** button until you see a message informing you to label this key as a MyKey. The key will be restricted at the next start.

MyKey is successfully created. Make sure you label it so you can distinguish it from the admin keys.

You can also program configurable settings for the key(s). See

Programming/Changing Configurable Settings.

Programming/Changing Configurable Settings

Use the information display to access your configurable MyKey settings.

1. Switch the ignition on using an admin key or remote control.
2. Access the main menu on the information display controls. Use the arrow keys to get to the following menu selections:

Message	Action and Description
Settings	Press the OK button or the right arrow key.
MyKey	Press the OK button or the right arrow key.

Note: You can clear or change your MyKey settings at any time during the same key cycle as you created the MyKey. Once you have switched the vehicle off, however, you will need an admin key to change or clear your MyKey settings.

CLEARING ALL MYKEYS

You can clear or change your MyKey settings using the information display control on the steering wheel. See **Information Displays** (page 67).

Switch the ignition on using an admin key or remote control.

MyKey™

To clear all MyKeys of all MyKey settings, press the left arrow button to access the main menu and scroll to:

Message	Action and Description
Settings	Press the OK button.
MyKey	Press the OK button.
Clear MyKey	Press and hold the OK button until the following message displays.
All MyKeys Cleared	

Note: *When you clear your MyKeys, you remove all restrictions and return all MyKeys to their original admin key status.*

CHECKING MYKEY SYSTEM STATUS

You can find information on programmed MyKey(s) using the information display control on the steering wheel. See **Information Displays** (page 67).

To find information on programmed MyKey(s), press the left arrow button to access the main menu and scroll to:

Message	Description
Settings	Press the OK button.
MyKey	Press the OK button.
Select one of the following:	
MyKey Dist.	Tracks the distance when drivers use a MyKey. The only way to delete the accumulated distance is by using an admin key to clear your MyKeys. If the distance does not accumulate as expected, then the intended user is not using the MyKey, or an admin key user recently cleared and then recreated a MyKey.
{0} MyKeys	Indicates the number of MyKeys programmed to your vehicle. Use this feature to detect how many MyKeys you have for your vehicle and determine when a MyKey has been deleted.
{0} Admin Keys	Indicates how many admin keys are programmed to your vehicle. Use this feature to determine how many unrestricted keys you have for your vehicle, and detect if an additional MyKey has been programmed.

MYKEY TROUBLESHOOTING

Condition	Potential Causes
I cannot create a MyKey.	<ul style="list-style-type: none"> • The key or transmitter used to start the vehicle does not have admin privileges. • The key or transmitter used to start the vehicle is the only admin key (there always has to be at least one admin key). • SecuriLock passive anti-theft system is disabled or in unlimited mode.
I cannot program the configurable settings.	<ul style="list-style-type: none"> • The key or transmitter used to start your vehicle does not have admin privileges. • No MyKeys are created. See Creating a MyKey (page 30).
I cannot clear the MyKeys.	<ul style="list-style-type: none"> • The key or transmitter used to start your vehicle does not have admin privileges. • No MyKeys are created. See Creating a MyKey (page 30).
I lost the only admin key.	Purchase a new key from an authorized dealer.
I lost a key.	Program a spare key. See Passive Anti-Theft System (page 39).
MyKey distances do not accumulate.	<ul style="list-style-type: none"> • The MyKey user is not using the MyKey. • An admin key holder cleared the MyKeys and created new MyKeys. • The key system has been reset.

Locks

LOCKING AND UNLOCKING

Power Door Locks

The power door lock control is on the driver and front passenger door panels.

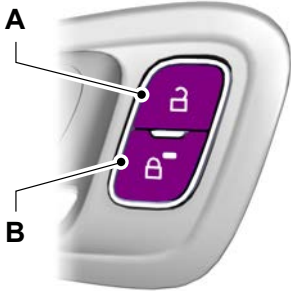

E184784

- A Unlock.
- B Lock.

Remote Control

You can use the remote control at any time while your vehicle is switched off.

Unlocking the Doors



Press the button to unlock all doors. The direction indicators will flash.

Note: You can unlock the driver's door with the key. Use the key when the remote control is not functioning.

Note: When you leave your vehicle locked for several weeks, the remote control will be switched off. Your vehicle must be unlocked with key and started. Unlocking and starting your vehicle once will enable the remote control.

Reprogramming the Unlocking Function

You can reprogram the unlocking function so that only the driver door is unlocked. See **Remote Control** (page 26).

Locking the Doors



Press the button to lock all the doors. The direction indicators will flash.

Note: If any door or the luggage compartment is not closed, or if the hood is not closed on vehicles that have an anti-theft alarm or remote start, the direction indicators will not flash.

Automatic Relocking

The doors will automatically relock if you do not open a door within 45 seconds of unlocking the doors with the remote control. The door locks and the alarm will return to their previous state.

Locking and Unlocking the Doors from Inside

Use the lock and unlock buttons located on the driver and passenger doors.

Locking and Unlocking the Doors with the Key

Locking with the Key

Turn the top of the key toward the front of your vehicle.

Unlocking with the Key

Turn the top of the key toward the rear of your vehicle.

Note: If the child safety locks are on and you pull the interior handle, you will only turn off the emergency locking, not the child safety lock. You can only open the doors using the external door handle.

Locks

Locking and Unlocking the Doors Individually with the Key - Vehicles with Central Locking

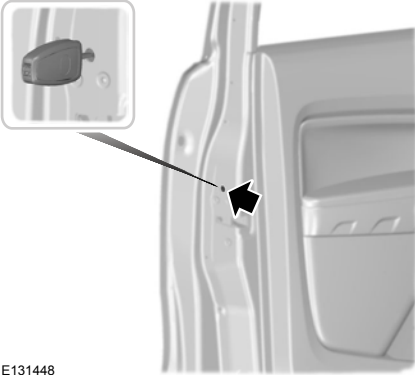

E131448

Locking

If the central locking function fails to operate, lock the doors individually by inserting the key into the exterior door handle key slot and rotating it.

Left-Hand Side

Turn clockwise to lock.

Right-Hand Side

Turn counterclockwise to lock.

Unlocking

If the central locking function fails to operate, unlock the driver door and then unlock all other doors individually by pulling the interior door handles.

Note: *If the doors have been unlocked using this method, the doors must be locked individually until the central locking function has been repaired.*

Opening the Liftgate

With the Remote Control



Press the button twice within three seconds.

From Outside Your Vehicle

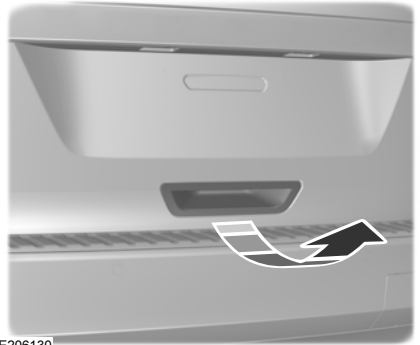

E206130

Press the release button below the license plate to unlatch the liftgate. Your vehicle must be unlocked or have an intelligent access transmitter within 1 m of the liftgate.

MANUAL LIFTGATE

WARNINGS



It is extremely dangerous to ride in a cargo area, inside or outside of a vehicle. In a crash, people riding in these areas are more likely to be seriously injured or killed. Do not allow people to ride in any area of your vehicle that is not equipped with seats and seatbelts. Be sure everyone in your vehicle is in a seat and using a seatbelt properly. Failure to follow this warning could result in serious personal injury or death.

Locks

WARNINGS



Make sure to close and latch the liftgate to prevent drawing exhaust fumes into your vehicle. This will also prevent passengers and cargo from falling out. If you must drive with the liftgate open, keep the vents or windows open so outside air comes into your vehicle. Failure to follow this warning could result in serious personal injury.

Note: Be careful when opening or closing the liftgate in a garage or other enclosed area to avoid damaging the liftgate.

Note: Do not hang anything, for example a bike rack, from the glass or liftgate. This could damage the liftgate and its components.

Note: Do not leave the liftgate open while driving. This could damage the liftgate and its components.

Opening the Liftgate

Manually

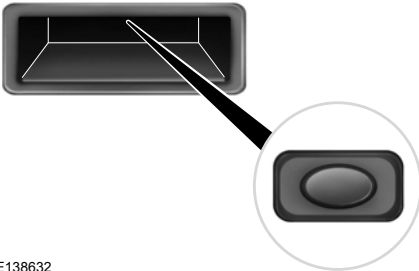

E138632

Note: The manual liftgate button must be enabled before it can be used, using the unlock button on the remote control.

Press the button located in the top of the liftgate pull cup handle to unlatch the liftgate, and then pull on the outside handle.

With the Remote Control



Press the button twice within three seconds.

Closing the Liftgate



E155976

A handle is located inside the liftgate to help with closing.

POWER LIFTGATE

WARNINGS



Do not operate the liftgate unless it is free from obstruction.



Careless opening and closing of the liftgate can override the protection function and cause injuries.



Do not place objects on the liftgate.



Make sure you fully close the liftgate after operation.



Operate the liftgate only when your vehicle is stationary.

You can operate the liftgate using the remote control, the instrument panel switch, or the liftgate switch.

Note: Make sure there is enough headroom to open the liftgate.

Locks

Note: If your vehicle has an automatic transmission, make sure the transmission selector lever is in park.

Note: In extreme weather conditions, automatic opening and closing will not work with the liftgate frozen to the seal.

Note: The liftgate will stop automatically while opening and reverse some distance if there is an obstacle in the way.

Note: The liftgate will stop automatically while closing and fully open if there is an obstacle in the way.

Note: You can manually operate the liftgate.

Liftgate Switch

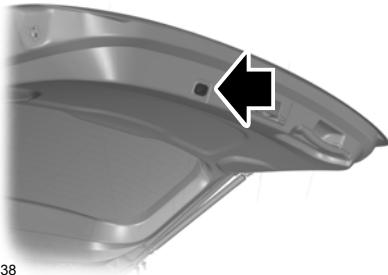

E129838



Switch the ignition on to operate the liftgate using the center console switch.

Note: A tone sounds three times when the liftgate begins to close.

Five short tones indicate a malfunction with the open or close request. This could be caused by one of the following:

- You switch the ignition on and the transmission selector lever is not in park.
- The battery voltage is below the minimum operating voltage.
- Your vehicle speed exceeds 3 mph (5 km/h).

To open a fully closed liftgate, you can either:

- Press the button on the remote control twice within three seconds.
- Press the center console switch.
- Use the liftgate switch.

To fully open a partially opened liftgate, you can either:

- Press the button on the remote control twice within three seconds.
- Press the center console switch or the liftgate switch.
- Use the liftgate switch.

To stop the liftgate, you can either:

- Press the button on the remote control. A further remote control operation will be delayed for approximately three seconds.
- Press the center console switch or the liftgate switch.
- Use the liftgate switch.

Closing the Liftgate

WARNING



The bounce-back feature will not work and it will not detect obstacles when the liftgate is in contact with the vehicle body.

Note: Do not leave a passive key in your vehicle when closing the liftgate. A message will be shown in the display. See **Information Messages** (page 76).

Note: A recessed grip is located inside the liftgate to help with closing.

You can either:

- Press the button on the remote control twice within three seconds.
- Press the center console switch or the liftgate switch.

Locks

- Use the liftgate release switch.
- Manually close the liftgate

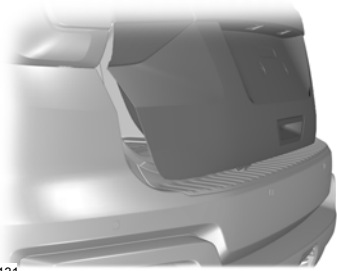

E206131

The liftgate will close automatically when it comes into contact with the vehicle body.

Programming Liftgate Height

You can set the power liftgate height as desired by following the below steps.

1. Open the liftgate.
2. Manually move the liftgate to the desired height.
3. Press and hold the liftgate switch for at least three seconds. A tone sounds when the desired height has been set.

Security

PASSIVE ANTI-THEFT SYSTEM

Principle of Operation

The system prevents someone from starting the engine with an incorrectly coded key.

Coded Keys

If you lose a key, you can purchase a replacement from an authorized dealer. If possible, provide them with the key number from the tag provided with the original keys. You can also obtain extra keys from an authorized dealer.

Note: *Have all of your remaining keys erased and recoded if you lose a key. Have replacement keys coded together with recoding your remaining keys. See an authorized dealer for further information.*

Note: *Do not shield your keys with metal objects. This may prevent the receiver from recognizing a coded key.*

Arming the Engine Immobilizer

When you switch the ignition off the engine immobilizer will arm automatically after a short time.

Disarming the Engine Immobilizer

When you switch the ignition on the engine immobilizer will disarm automatically if a correctly coded key is used.

If you are unable to start the engine with a correctly coded key, have your vehicle checked by an authorized dealer.

ANTI-THEFT ALARM

Alarm System

Your vehicle may have one or more of the following alarm systems:

- Perimeter alarm with interior sensors.
- Perimeter alarm with interior sensors and battery back-up sounder.
- Inclination or motion sensor to set off the alarm if the vehicle is moved or raised.

Perimeter Alarm

The perimeter alarm is a deterrent against unauthorized access to your vehicle through the doors, luggage compartment and the hood.

Panic Alarm

The alarm can be activated using the remote control.

Interior Sensors



The sensors act as a deterrent against unauthorized access by sensing any movement within your vehicle.

Arming the alarm turns on the interior sensors.

Note: *Do not cover the interior lamp scanning sensors.*

Security

Note: Do not arm the alarm with full guard if passengers, animals or other moving objects are inside your vehicle, as this could trigger the alarm.

Note: Do not leave the glasses holder open.

Note: To permanently switch off the interior motion sensor, see an authorized dealer.

Note: Fuel fired heater may trigger false alarms.

Inclination/ Motion Sensor

The sensors act as a deterrent against unauthorized access by sensing any movement within your vehicle.

Triggering the Alarm

- If someone opens a door or the hood without a valid key or remote control.
- If someone removes the multi-function display.
- If you switch the ignition on without a valid key.
- If the interior sensors detect movement within your vehicle.
- On vehicles with a battery back-up sounder, if someone disconnects your vehicle battery or the battery back-up sounder itself.

If the alarm sounds, the alarm horn will sound for 30 seconds and the hazard warning lamps flash for five minutes.

Any further attempts to carry out one of the above will sound the alarm again.

Full and Reduced Guard

Full Guard

Full guard is the standard setting.

In full guard, the interior sensors are on when you arm the alarm.

Note: Do not arm the alarm with full guard if passengers, animals or other moving objects are inside your vehicle, as this could trigger the alarm.

Reduced Guard

In reduced guard, the interior sensors are off when you arm the alarm.

Note: You can set the alarm to reduced guard for the current ignition cycle only.

Selecting Full or Reduced Guard

Full guard is the standard setting.

You can switch this feature on or off and adjust the settings using the information display.

Note: You can set the alarm to reduced guard for the current ignition cycle only.

The alarm resets to full guard the next time you unlock and then relock the vehicle with the remote control.

Arming the Alarm

Press the lock button once to lock your vehicle and arm the alarm.

Disarming the Alarm

Disarm the alarm by any of the following actions:

- Unlock the doors with the key and switch the ignition on with a correctly coded key within 12 seconds.
- Unlock the doors or luggage compartment using the remote control.

Steering Wheel

ADJUSTING THE STEERING WHEEL

WARNING

 Do not adjust the steering wheel when your vehicle is moving.

Note: Make sure that you are sitting in the correct position.



E161488

1. Unlock the steering column.
2. Adjust the steering wheel to the desired position.



E95179

3. Lock the steering column.

AUDIO CONTROL

Select the required source on the audio unit.

You can operate the following functions with the control:

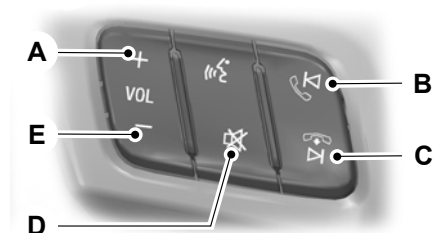

E199065

- A Volume up.
- B Seek down or previous.

Steering Wheel

- C Seek up or next.
- D Mute.
- E Volume down.

VOICE CONTROL



E200787

- A Press the button to switch on or off the voice control.
- B Press the button to accept phone call.
- C Press the button to end phone call.

CRUISE CONTROL

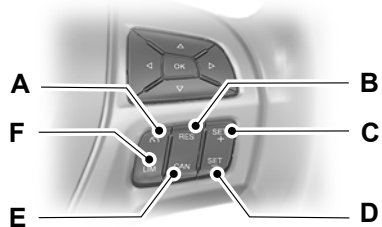

E200943

- A Cruise control On and off.
- B Resume.
- C Set speed increase.
- D Set speed decrease.
- E Cancel.
- F Speed limiter on and off.

INFORMATION DISPLAY CONTROL



E201420

See **General Information** (page 67).

Wipers and Washers

WINDSHIELD WIPERS

Note: Fully defrost the windshield before you switch the windshield wipers on.

Note: Make sure you switch the windshield wipers and vehicle power off before using an automatic car wash.

Note: If streaks or smears appear on the windshield, clean the windshield and the wiper blades. See **Windshield Wipers** (page 43). If that does not resolve the issue, install new wiper blades. See **Changing the Wiper Blades** (page 208).

Note: Do not operate the wipers on a dry windshield. This may scratch the glass, damage the wiper blades or cause the wiper motor to burn out. Always use the windshield washers before wiping a dry windshield.

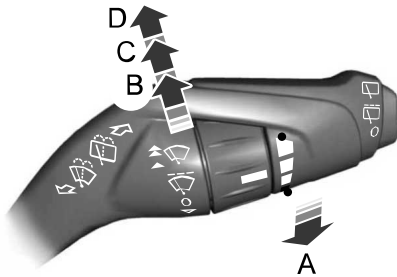

E222239

- A Single wipe.
- B Intermittent wipe.
- C Normal wipe.
- D High-speed wipe.

Note: Move to position **O** marked on the wiper lever to switch off.

Note: Make sure the wiper is switched off before switching the ignition off. Otherwise, the wipers will stop at the current operating position.

Intermittent Wipe

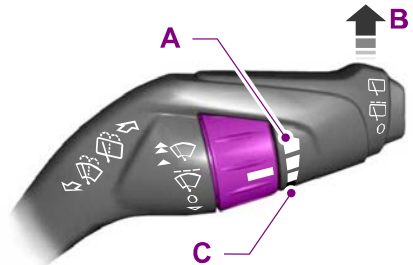

E222240

- A Short-wipe interval.
- B Intermittent wipe.
- C Long-wipe interval.

Push the wiper lever up to switch the wipers on, and then use the rotary control to adjust the intermittent wipe interval.

Speed Dependent Wipers

When your vehicle speed increases, the interval between wipes decreases.

AUTOWIPERS (If Equipped)

Note: Fully defrost the windshield before switching on the windshield wipers.

Note: Make sure you switch off the windshield wipers before entering a car wash.

Note: Clean the windshield and wiper blades if they begin to leave streaks or smears. If that does not resolve the issue, install new wiper blades.

Note: If you switch on the autolamps with the autowipers, the low beam headlamps will turn on automatically when the rain sensor turns on the windshield wipers continuously.

Wipers and Washers

Note: During wet or winter driving conditions with ice, snow or a salty road mist, inconsistent or unexpected wiping or smearing may occur.

In these conditions, you can do the following:

- Lower the sensitivity of the autowipers to reduce the amount of smearing.
- Switch to normal or high-speed wipe.
- Switch the autowipers off.

Note: Make sure the wiper is switched off before switching the ignition off. Otherwise, the wipers will stop at the current operating position.

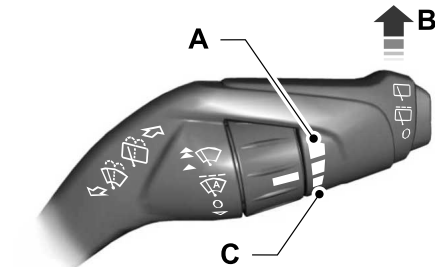

E168041

- A High sensitivity.
- B On.
- C Low sensitivity.

The autowipers feature uses a rain sensor that is located in the area around the interior rear view mirror. The rain sensor monitors the amount of moisture on the windshield and automatically turns the wipers on. It will adjust the wiper speed by the amount of moisture that the sensor detects on the windshield.

Use the rotary control to adjust the sensitivity of the rain sensor. Set the control to low sensitivity, and the wipers will turn on when the rain sensor detects a large amount of moisture on the windshield. Set the control to high sensitivity, and the wipers will turn on when the rain sensor detects a small amount of moisture on the windshield.

Keep the outside of the windshield clean. The rain sensor is very sensitive. Dirt or debris around the interior rear view mirror area will affect the autowipers' performance. For example, the autowipers may turn on if dirt, mist or insects hit the windshield.

WINDSHIELD WASHERS

Note: Do not operate the washers when the washer reservoir is empty. This may cause the washer pump to overheat.

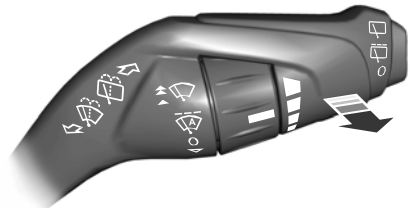

E168042

To operate the windshield washers, pull the lever toward you. The wiper will be activated within a second.

In order to reduce water usage, the washer is functioned to stop after operating continuously for 10 seconds. Pull the lever to operate the washer again.

Wipers and Washers

REAR WINDOW WIPER AND WASHERS

Rear Window Wiper

Note: Fully defrost the rear window before switching on the rear window wiper.

Note: Make sure you switch off the rear window wipers before entering a car wash chamber.

Note: Clean the rear window and wiper blades if they begin to leave streaks or smears. If that does not resolve the streaking issue, install new wiper blade(s).

Note: Turn off the wipers before turning off the vehicle or the wipers will be stopped in their current position on the window.



E168043

- A Intermittent wipe.
- B Low-speed wipe.
- C Off.

Press the top of the button at the end of the lever to switch on the intermittent wiper. Press the button again to switch on low-speed wipe. Press the bottom of the button to switch the wiper off, or to change the wiper speed from low-speed to intermittent.

When you shift the transmission into reverse (R) the rear wiper will turn on to intermittent if the front wipers are activated.

Note: The rear wiper will only activate when the liftgate is closed.

Rear Window Washer

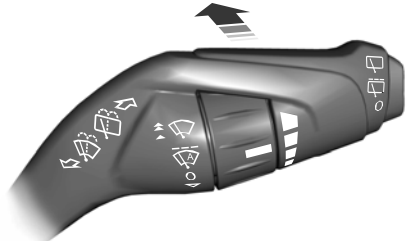

E168044

To use the rear washer function, push the lever away from you. The rear wiper will then be activated within one second to clear the washer fluid from the rear window during the rear window wash cycle.

To reduce water usage, the rear washer can only be operated for 10 continuous seconds. The washer fluid pump can be reactivated by activating the rear washer again.

HEADLAMP WASHERS

Note: The headlamp washer system is automatic and does not have a dedicated control switch.

Headlamp washers operate when the low beam headlamps are ON and the windshield washer is operated, then with very fifth cycle of windshield wash.

Lighting

GENERAL INFORMATION

Condensation in Lamp Assemblies

Exterior lamps have vents to accommodate normal changes in air pressure.

Condensation can be a natural by-product of this design. When moist air enters the lamp assembly through the vents, there is a possibility that condensation can occur when the temperature is cold. When normal condensation occurs, a fine mist can form on the interior of the lens. The fine mist eventually clears and exits through the vents during normal operation.

Clearing time may take as long as 48 hours under dry weather conditions.

Examples of acceptable condensation are:

- The presence of a fine mist (no streaks, drip marks or large droplets).
- A fine mist covers less than 50% of the lens.

Examples of unacceptable condensation are:

- A water puddle inside the lamp.
- Streaks, drip marks or large droplets present on the interior of the lens.

If you see any unacceptable condensation, have your vehicle checked by an authorized dealer.

LIGHTING CONTROL



E142449

- A Off.
- B Position lamps, instrument panel lamps, license plate lamps and tail lamps.
- C Headlamps.

WARNING



Prolonged use of the position lamps when the ignition is off will cause the battery to run out of charge.

Note: Switch on the position lamps within 10 minutes from the key out, reinsert the key if exceeded.

Select position B on the lighting control to switch the parking lamps on. The parking lamps operate with the ignition on or off.

Single Side Parking Lamps

WARNING



Prolonged use of the single side parking lamps when the ignition is off will cause the battery to run out of charge.

Single side parking lamps operate with the ignition on or off.

Lighting

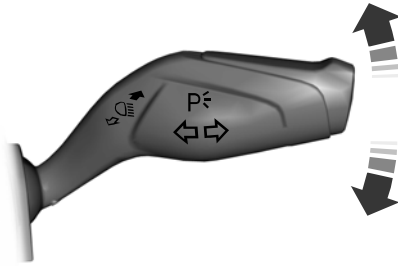

E211866

Move the lever up or down to switch on the desired single side parking lamp.

High and Low Beam

Push the lever forward to switch between high beam and low beam.

Headlamp Flasher

Slightly pull the lever toward you and release it to flash the headlamps.

AUTOLAMPS

WARNING



The autolamps switch position may not activate the headlamps in all low visibility conditions, such as daytime fog. Always ensure that your headlamps are switched to auto or on, as appropriate, during all low visibility conditions. Failure to do so may result in a collision.

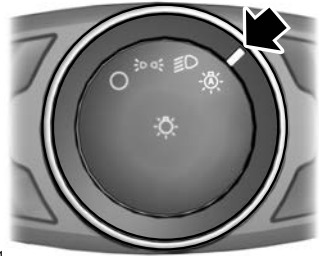

E142451

When the lighting control is in the autolamps position, the headlamps automatically turn on in low light situations or when the wipers activate.

The following also activate when the lighting control is in the autolamps position and you switch them on in the information display:

- Configurable daytime running lamps.
- Automatic high beam control.

The headlamps remain on for a period of time after you switch the ignition off. Use the information display controls to adjust the period of time that the headlamps remain on. See **Information Displays** (page 67).

Note: *With the headlamps in the autolamps position, you cannot switch the high beam headlamps on until the autolamps system turns the low beam headlamps on.*

AUTOMATIC HIGH BEAM CONTROL

WARNINGS



The system does not relieve you of your responsibility to drive with due care and attention. A manual override may be necessary if the system fails to switch the high beam on or off.

Lighting

WARNINGS



A manual override may be required when approaching other road users such as cyclists.



Do not use the system in fog.



In cold and severe weather conditions the system may not function. A manual override may be necessary in these cases.



The system may not deactivate the high beam if the lights of oncoming vehicles are hidden by obstacles (for example guard rails).



Check and replace wiper blades regularly to ensure the camera sensor has a clear view through the windscreen. Replacement wiper blades must be the correct length.

Note: Keep the windscreen free from obstructions such as bird droppings, insects and snow or ice.

Note: Reflective road signs may be detected as oncoming traffic and the headlamps will be switched to low beam.

Note: Always fit Ford Original Parts when replacing headlamp bulbs. Other bulbs may reduce system performance.

The system will automatically switch on high beams if it is dark enough and no other traffic is present. If it detects an approaching vehicle's headlamps or tail lamps, or street lighting ahead the system will switch off high beam before it can distract other road users. Low beam will remain on.

A camera sensor is centrally mounted behind the windshield of your vehicle. This monitors conditions continuously to decide when to switch the high beams on and off.

Once the system is active the high beam will switch on if:

- It is dark enough to require the use of high beams and
- there is no traffic or street lighting ahead and
- vehicle speed is greater than approximately 40 km/h .

The high beam will switch off if:

- The ambient light is high enough that high beam is not required.
- An approaching vehicle's headlamps or tail lamps are detected.
- Street lighting is detected.
- Vehicle speed falls below approximately 25 km/h.
- The camera sensor is too hot or becomes blocked.

Activating the System

Switch the system on using the information display. See **General Information** (page 67). Turn the switch to the autolamps position. See **Autolamps** (page 47).

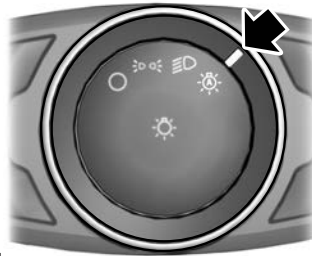

E142451

The indicator will illuminate to confirm when the system is ready to assist.

Lighting

Manually Overriding the System



E169254

Push or pull the lever to switch between high and low beam.

Note: This is a temporary override and the system will return to automatic operation after a short period.

To permanently switch the system off, use the information display menu or turn the lighting control switch to the headlamps position.

DAYTIME RUNNING LAMPS

WARNING



Always remember to switch your headlamps on in low light situations or during inclement weather. The system does not activate the tail lamps and may not provide adequate lighting during these conditions. Failure to activate your headlamps under these conditions may result in a collision.

To switch the system on:

1. Switch the ignition on.
2. Switch the lighting control to the off or autolamp position.

FRONT FOG LAMPS



E132709

Press the control to switch the fog lamps on or off.

You can switch the fog lamps on when the lighting control is in any position except off.

Note: Only use fog lamps during reduced visibility, for example, fog, snow or heavy rain.

REAR FOG LAMPS



E132710

Press the control to switch the fog lamps on or off.

You can only switch the rear fog lamps on when either the front fog lamps or low beam headlamps are on.

Note: Only use the rear fog lamps when visibility is less than 50 m.

Lighting

Note: Do not use the rear fog lamps when it is raining or snowing.

Note: If you switch autolamps on, you can only switch the fog lamps on once autolamps has turned the headlamps on.

HEADLAMP LEVELING

Headlamp leveling is provided to avoid glare for other road users when the vehicle is loaded in a number of different conditions.

To adjust the level of the headlamp beams:



E132711

1. Press to release the control.
2. Rotate the control to the required setting.
3. Press to close the control.

Set the headlamp leveling to the corresponding setting, depending on the vehicles loading condition.

Vehicle Loading Condition Setting

	0
	0
	1
	1
	2
	3

Set the headlamp leveling to the corresponding switch setting, depending on the vehicles loading condition.

Set the headlamp leveling control to zero when your vehicle is unloaded.

Lighting

DIRECTION INDICATORS



E169255

Push the lever up or down to use the direction indicators.

Note: Tap the lever up or down to make the direction indicators flash three times to indicate a lane change.

AMBIENT LIGHTING (If Equipped)

Adjust the ambient lighting using the touchscreen.

INTERIOR LAMPS

The lamps will turn on when you have met one of the following conditions:

- You open any door.
- You press a remote control button.
- You press button A on the overhead console.

Front Interior Lamp

Note: The front interior lamp buttons are on the overhead console. The exact location of each button on the overhead console depends upon which roof, moonroof, and window shade features are equipped on the vehicle.

Note: Press button C to switch the door function off when you open any door. The indicator lamp will light amber when the door function is off. When the door function is off and you open a door, the dome and map lamps will stay off. Press button C again to switch the door function back on. The indicator lamp will light blue when the door function is on. When the door function is on and you open a door, the dome and map lamps will light.

With Moonroof



E201210

- A Individual map lamps.
- B All lamps on button.
- C Door function button.

Lighting

Without Moonroof

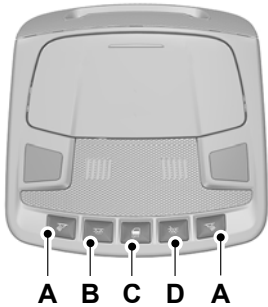

E201211

- A Individual map lamps.
- B All lamps on button.
- C Door function button.
- D All lamps off button.

You can switch individual lamps on independently by pressing a lamp button.

Rear Interior Lamp

2nd Row Seats

With Moonroof

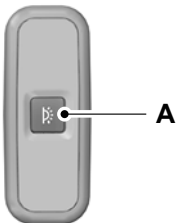

E201099

- A Press the button to switch map lamps on or off.

Without Moonroof

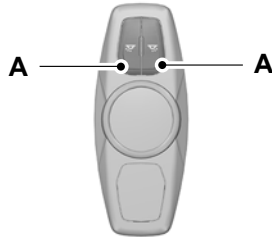

E201084

- A Press the button to switch individual map lamps on or off.

3rd Row Seats

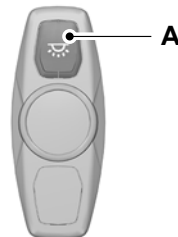

E204767

- A Press the button to switch dome lamps on or off.

Glove Box Lamp

The glove box will be illuminated when it is opened.

Cargo Compartment Lamp

The cargo compartment will be illuminated when the rear liftgate is opened.

Windows and Mirrors

POWER WINDOWS

WARNINGS

 Do not leave children unattended in your vehicle and do not let them play with the power windows. They may seriously injure themselves.

 When closing the power windows, you should verify they are free of obstructions and make sure that children and pets are not in the proximity of the window openings.

 If the vehicle is to be left unsupervised, the vehicle key should be taken to ensure that the windows are not operated inadvertently.

 Do not operate the electric windows unless they are free from obstruction.

Note: If you operate the switches often during a short period of time, the system might become inoperable for a certain time to prevent damage due to overheating.

Note: If you operate both the switch on the relevant door and the switch for that window on the driver's door at the same time, the window will stop moving.

Note: You may hear a rumbling noise when just one of the windows are open. Lower the opposite window slightly to reduce this noise.

Driver's Door Switches

You can operate all the windows with the switches on the door trim panel of the driver's door.

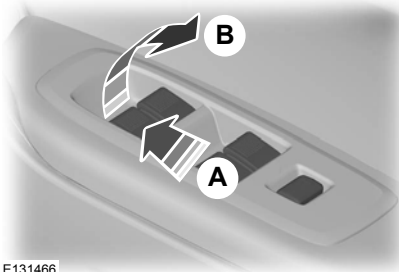

E131466

- A Press the switch to open the window.
- B Lift the switch to close the window.

Front and Rear Passengers' Door Switches

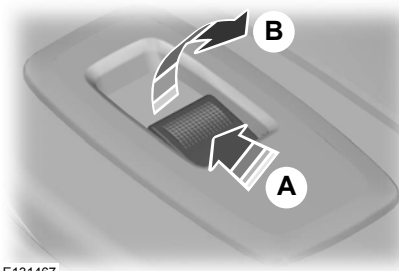

E131467

- A Press the switch to open the window.
- B Lift the switch to close the window.

Opening and Closing the Driver Side Window Automatically

Press or lift the switch to the second action point and release it. Press or lift it again to stop the window.

Windows and Mirrors

Opening and Closing Other Windows Automatically

Press or lift the switch to the second action point and release it. Press or lift it again to stop the window.

Safety Switch for the Rear Windows

Note: You can always operate the rear and front passenger windows from the driver's door if global opening and closing is fitted.

Note: On vehicles without global opening and closing, the rear windows cannot be operated from driver side when the safety switch is pressed.

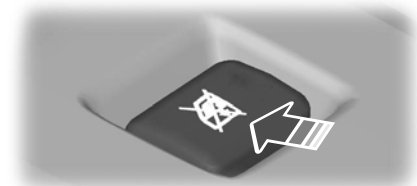

E131468

A switch in the driver's door disables the rear passenger electric window switches.

The indicator in the safety switch turns on once the switch is pressed.

Resetting the Memory of the Electric Windows - Vehicle with One Touch Up/Down on Driver Side only

WARNING



The anti-trap function is deactivated until you have reset the memory.

In the event of a flat battery or after the battery has been disconnected from the vehicle, you must reset the memory for driver window.

1. Open the window.

2. Lift and hold the switch to second action point until the window is fully closed.
3. Hold the switch lifted for more than two seconds and release.
4. Open the window using the first action point and try to close it automatically using second action point.
5. If the window does not open or close automatically when the switch is pressed or lifted to second action points, repeat the procedure.

Anti-trap windows

Anti-trap windows are designed to prevent objects from getting caught between the glass and the seal when the electric window is closed. Upon sensing an obstruction, the window automatically re-opens and allows the trapped object to be removed.

Safety Mode

WARNINGS



The anti-trap function is not active during this procedure.



While you close the window (auto-up) for the third time with the obstacle in the way, the anti-trap function is disabled. Make sure there are no obstacles in the way of the closing window.

If the system detects a malfunction, it enters a safety mode. The windows will move for only about 0.8 seconds at a time and then stop again. Close the windows by lifting the switch again when the windows stop moving. Have this checked immediately.

Windows and Mirrors

Bounce-Back

The window will stop automatically while closing. It will reverse some distance if there is an obstacle in the way.

Overriding the Bounce-Back Feature

WARNING



When you override the bounce-back feature the window will not reverse if it detects an obstacle. Take care when closing the windows to avoid personal injury.

Proceed as follows to override this protection feature when there is a resistance, for example in winter:

1. Close the window twice until it reaches the point of resistance and let it reverse.
2. Close the window a third time to the point of resistance.

Note: *This operation should occur within two seconds after the window reaches the reversing end position.*

3. The bounce-back feature is now disabled and you can close the window manually. The window will go past the point of resistance and you can close it fully.

See an authorized dealer as soon as possible if the window does not close after the third attempt.

Resetting the Bounce-Back Feature

WARNING



The bounce-back feature remains turned off until you reset the memory.

If you have disconnected the battery, you must reset the bounce-back memory separately for each window.

1. Lift and hold the switch until the window is fully closed.
2. Release the switch.
3. Lift the switch again for one more second.
4. Press and hold the switch until the window is fully open.
5. Release the switch.
6. Lift and hold the switch until the window is fully closed.
7. Open the window and then try to close it automatically.
8. Reset and repeat the procedure if the window does not close automatically.

GLOBAL OPENING AND CLOSING

You can use the remote control to operate the windows with the ignition off.

Note: *You can enable or disable this feature in the information display or see an authorized dealer. See **General Information** (page 67).*

Note: *To operate this feature, accessory delay must not be active.*

Opening the Windows

You can only open the windows for a short time after you unlock your vehicle with the remote control. After you unlock your vehicle, press and hold the remote control unlock button to open the windows and vent the moonroof. Release the button once movement starts. Press the lock or unlock button to stop movement.

Windows and Mirrors

Closing the Windows

WARNING

 When closing the windows and moonroof, you should verify they are free of obstructions and make sure that children and pets are not in the proximity of the window openings.

To close the windows and moonroof, press and hold the remote control lock button. Release the button once movement starts. Press the lock or unlock button to stop movement.

EXTERIOR MIRRORS

Power Exterior Mirrors

WARNING

 Do not adjust the mirrors when your vehicle is moving. This could result in the loss of control of your vehicle, serious personal injury or death.

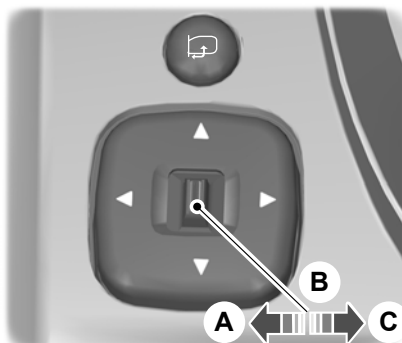

E131480

- A Left-hand side.
- B Off.
- C Right-hand side.

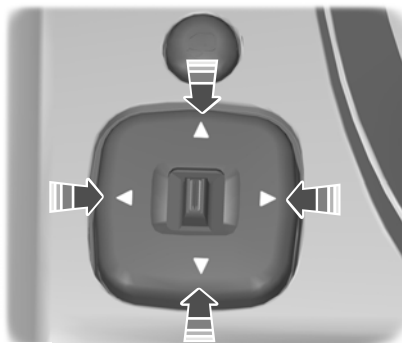

E131481

Press the arrows to adjust the mirror.

Heated Exterior Mirrors

The heated exterior mirrors will remove ice, mist and fog.

Windows and Mirrors

Fold-Away Exterior Mirrors

Push the mirror toward the door window glass.

Make sure that you fully engage the mirror in its support when returning it to its original position.

Power-Folding Mirrors

The power folding mirrors operate with the ignition on, and for several minutes after you switch the ignition off.

Note: *The mirrors no longer operate if you switch the ignition off and open a door.*

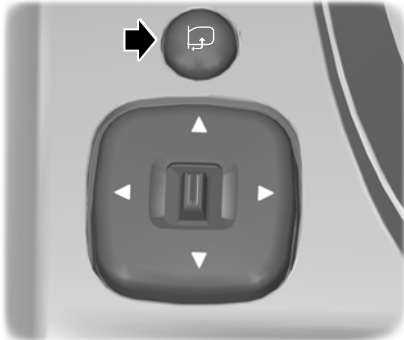

E131482

Press the button to fold the mirrors inward.

Release the button to stop and reverse the direction of movement, or to fold the mirrors outward.

INTERIOR MIRROR

WARNING



Do not adjust the mirror when your vehicle is moving.

Note: *Do not clean the housing or glass of any mirror with harsh abrasives, fuel or other petroleum or ammonia-based cleaning products.*

You can adjust the interior mirror to your preference. Some mirrors also have a second pivot point. This lets you move the mirror head up or down and from side to side.

Pull the tab below the mirror toward you to reduce glare at night.

Auto-Dimming Mirror

Note: *Do not block the sensors on the front and back of the mirror. Mirror performance may be affected. A rear center passenger or raised rear center head restraint may also block light from reaching the sensor.*

The mirror will dim automatically to reduce glare when bright lights are detected from behind your vehicle. It will automatically return to normal reflection when you select reverse gear to make sure you have a clear view when backing up.

MOONROOF (If Equipped)

WARNINGS



Do not let children play with the moonroof or leave them unattended in the vehicle. They may seriously hurt themselves.



When closing the moonroof, you should verify that it is free of obstructions and make sure that children and pets are not in the proximity of the roof opening.

The moonroof controls are located on the overhead console and have a one-touch open and close feature. To stop it during one-touch operation, touch the control a second time.

Windows and Mirrors

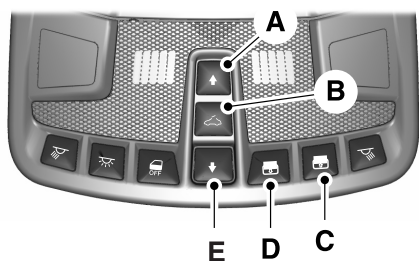

Touch and hold **C** within two seconds of a bounce-back event to override this function.

E191272

- A **Moonroof:** Press and release to open the moonroof. The moonroof stops short of the fully opened position. Press and release the control again to open the moonroof fully.
- B **Moonroof vent:** Press and release to vent the moonroof.
- C **Sunshade open:** Press and release to open the sunshade. The sunshade opens automatically with the moonroof. You can also open the sunshade with the moonroof closed. The sunshade stops short of its fully opened position for the comfort of rear passengers. To open the moonroof fully, press the control again.
- D **Sunshade close:** Press and release to close the sunshade.
- E **Moonroof close:** Press and release to close the moonroof from either the open or vent positions.

Bounce-Back

The moonroof will stop automatically and reverse some distance if an obstacle is detected while closing.

Instrument Cluster

GAUGES

Type 1

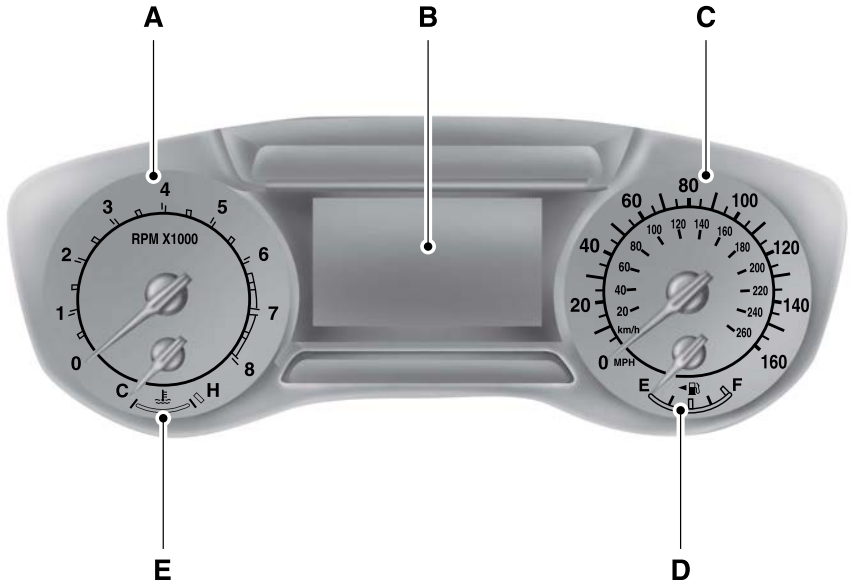

E144485

- A Tachograph.
- B Multi-function display.
- C Speedometer.
- D Fuel gauge.
- E Engine coolant temperature gauge.

Instrument Cluster

Type 2

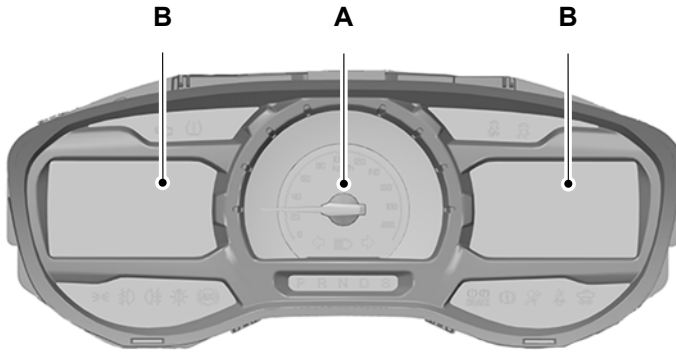

E205854

- A Speedometer.
- B Multi-function display.

Note: In the design and manufacture of instrumentation, Ford comply with the government regulations that the indicated value of the speedometer is not less than the actual speed. In normal operation, customers may be observed by other instruments (such as a GPS Unit) that the indicated speed is slightly faster than the actual vehicle speed. This is normal and does not represent an instrument malfunction.

Information Display

Odometer

Registers the accumulated distance your vehicle has traveled.

Outside Air Temperature

Shows the outside air temperature.

Compass

Displays the vehicle's heading direction.

Trip Computer

See **General Information** (page 67).

Vehicle Settings and Personalization

See **General Information** (page 67).

Engine Coolant Temperature Gauge

At normal operating temperature, the needle will remain in the center section. If the needle enters the red section, the engine is overheating. Stop the engine, switch the ignition off and determine the cause once the engine has cooled down.

Instrument Cluster

Note: Do not restart the engine until the cause of overheating has been determined and resolved.

WARNING



Never remove the coolant reservoir cap while the engine is running or hot.

Fuel Gauge

Switch the ignition on. The fuel gauge will indicate approximately how much fuel is left in the fuel tank. The arrow adjacent to the fuel pump symbol indicates on which side of your vehicle the fuel filler door is located.

After refueling some variability in needle position is normal:

Variations:

Driving type (fuel economy conditions)	Fuel gauge position	Distance-to-empty
Highway driving	1/16th	56–129 km
Severe duty driving (trailer towing, extended idle)	1/16th	56 km

WARNING LAMPS AND INDICATORS

The following warning lamps and indicators alert you to a vehicle condition that may become serious. Some lamps illuminate when you start your vehicle to make sure they work. If any lamps remain on after starting your vehicle, refer to the respective system warning lamp for further information.

Note: Some warning indicators appear in the information display and operate the same as a warning lamp but do not illuminate when you start your vehicle.

- It may take a short time for the needle to reach **F** after leaving the gas station. This is normal and depends upon the slope of pavement at the gas station.
- The fuel amount dispensed into the tank is a little less or more than the gauge indicated. This is normal and depends upon the slope of pavement at the gas station.
- If the gas station nozzle shuts off before the tank is full, try a different gas pump nozzle.

Low Fuel Reminder

A low fuel reminder triggers when the fuel gauge needle is at approximately 1/16th.

Note: Depending on your vehicle specification, some warning lamps and indicators may not be active.

Adaptive Cruise Control Lamp



The speed control system indicator light changes color to indicate what mode the system is in: See **Using Cruise Control** (page 146).

On (white light): Illuminates when the adaptive cruise control system is turned on. Turns off when the speed control system is turned off.

Engaged (green light): Illuminates when the adaptive cruise control system is engaged. Turns off when the speed control system is disengaged.

Instrument Cluster

Anti-Lock Braking System Warning Lamp



If it illuminates when you are driving, this indicates a malfunction. You will continue to have the normal braking system (without anti-lock braking system) unless the brake system warning lamp is also illuminated. Have your vehicle checked by an authorized dealer.

Automatic High Beam Lamp



It will illuminate when this feature is on. See **Autolamps** (page 47).

Battery Warning Lamp



If it illuminates when driving, this indicates a malfunction. Switch off all unnecessary electrical equipment. Have your vehicle checked by an authorized dealer immediately.

Blind Spot Monitor Indicator



It will illuminate when you switch this feature off or in conjunction with a message. See **Blind Spot Information System** (page 159). See **Information Messages** (page 76).

Brake System Warning Lamp



It will illuminate when you engage the parking brake with the ignition on.

If it illuminates when you are driving, check that the parking brake is not engaged. If the parking brake is not engaged, this indicates low brake fluid level or a brake system malfunction. Have your vehicle checked by an authorized dealer immediately.

WARNING



Driving your vehicle with the warning lamp on is dangerous. A significant decrease in braking performance may occur. It will take you longer to stop your vehicle. Have your vehicle checked by an authorized dealer immediately. Driving extended distances with the parking brake engaged can cause brake failure and the risk of personal injury.

Cruise Control Indicator



It will illuminate when you switch this feature on. See **Using Cruise Control** (page 146).

Direction Indicator



Illuminates when the left or right direction indicator or the hazard warning flasher is turned on. If the indicators stay on or flash faster, check for a burnt out bulb. See **Changing a Bulb** (page 210).

Door Ajar Indicator



It will illuminate when the ignition is on and any door is not completely closed.

Engine Coolant Temperature Warning Lamp



It will illuminate when the engine or motor coolant temperature is high. Stop your vehicle as soon as possible and contact your authorized dealer.

Instrument Cluster

Engine Oil Warning Lamp

WARNING



If it illuminates when you are driving do not continue your journey, even if the oil level is correct. Have your vehicle checked.



If it illuminates with the engine running or when you are driving, this indicates a malfunction. Stop your vehicle as soon as it is safe to do so and switch the engine off. Check the engine oil level.

Electronic Locking Differential



Illuminates when using the electronic locking differential.

Fasten Seat Belt Warning Lamp



It will illuminate and a chime will sound to remind you to fasten your seat belt. See **Seatbelt Reminder** (page 22).

Four-Wheel Drive Indicators



Illuminates when four-wheel drive low is engaged.

Front Airbag Warning Lamp



If the warning lamp does not illuminate during start up, remains on or flashes, the system may be disabled.

Have your vehicle checked by an authorized dealer.

Front Fog Lamps Indicator



It will illuminate when you switch the front fog lamps on.

Frost Warning Lamp

WARNING



Even if the temperature rises to above 4°C there is no guarantee that the road is free of hazards caused by inclement weather.



It will illuminate when the outside air temperature is 4°C or below.

Glow Plug Indicator



With the key in the on position, illuminates when the glow plug heat is necessary as a starting aid. Wait until the light goes off before starting.

After you start the engine, the light should turn off. When the engine is cold, the light should always illuminate for a short period.

High Beam Indicator



It will illuminate when you switch the high beam headlamps on. It will flash when you use the headlamp flasher.

Hill Descent Control



Illuminates when hill descent control is switched on.

Hood Ajar Warning Lamp



It will illuminate when the ignition is on and the hood is not completely closed.

Lane Keeping Aid Indicator



It will illuminate when you activate the lane keeping system.

Instrument Cluster

Liftgate Ajar Warning Lamp



It will illuminate when the liftgate is not completely closed.

AdBlue® Lamp



It will illuminate and a message will appear in the information display when the Diesel Exhaust Fluid (AdBlue®) level is low and needs to be refilled, or a fault is active in the system.

Low Fuel Level Warning Lamp



If it illuminates when you are driving, refuel as soon as possible.

Low Tire Pressure Warning



Will illuminate when your tire pressure is low. If the lamp remains on with the engine running or when driving, check your tire pressure as soon as possible.

It will also illuminate momentarily when you switch the ignition on to confirm the lamp is functional. If it does not illuminate when you switch the ignition on, or begins to flash at any time, have the system checked by an authorized dealer.

Low Washer Fluid



It illuminates when the windshield washer fluid is low.

Over Speed Warning



It will illuminate if the vehicle exceeds 120km/h.

Parking Lamps Indicator



It will illuminate when you switch the parking lamps on.

Powertrain Fault



It will illuminate when a powertrain or a four-wheel drive fault has been detected. Contact an authorized dealer as soon as possible.

Rear Fog Lamps Indicator



It will illuminate when you switch the rear fog lamps on.

Fasten Rear Seat Belt Warning Lamp



It will illuminate and a chime will sound to signal the rear seat belts are not buckled.

Service Engine Soon



The service engine soon indicator light illuminates when the ignition is first turned on prior to engine start to check the bulb. If the service engine soon indicator light stays illuminated after the engine is started, it indicates that the On Board Diagnostics system (OBD) has detected a malfunction of the vehicle emissions control system. Refer to the Fuel and Refueling chapter for more information about having your vehicle serviced.

WARNING



Under engine misfire conditions, excessive exhaust temperatures could damage the catalytic converter, the fuel system, interior floor coverings or other vehicle components, possibly causing a fire. Have an authorized dealer service your vehicle immediately.

Instrument Cluster

If the light is blinking, an engine misfire is occurring which could damage your catalytic converter. Drive in a moderate fashion (avoid heavy acceleration and deceleration) and have your vehicle serviced immediately.

Shift Indicator



It will illuminate to inform you that shifting to a higher gear as indicated may give better fuel economy and lower CO2 emissions. It will not illuminate during periods of high acceleration, braking or when the clutch pedal is pressed.

Speed Limiter



It will illuminate when you switch on the speed limiter system. See **Speed Limiter** (page 153).

Stability Control Warning Lamp



It will flash when the system is active. If it remains illuminated or does not illuminate when you switch the ignition on, this indicates a malfunction. During a malfunction the system will switch off. Have your vehicle checked by an authorized dealer immediately. See **Using Stability Control** (page 135).

Stability Control Off Indicator



It will illuminate when you switch the system off. It will go out when you switch the system back on or when you switch the ignition off. See **Using Stability Control** (page 135).

Water-In-Fuel Warning Lamp



It will illuminate when there is excess water in the fuel filter. Drain off the water immediately. See **Fuel Quality** (page 116).

AUDIBLE WARNINGS AND INDICATORS

Note: Depending on your vehicle options and instrument cluster type, not all of the audible warnings and indicators will display or be available.

Key in Ignition

Sounds when the driver door is open and the key is in the ignition.

Headlamps On

Sounds when you remove the key from the ignition and open the driver's door and you have left the headlamps or parking lamps on.

Parking Brake On

Sounds when the parking brake is on and your vehicle is moving.

If the warning chime remains on after you have released the parking brake, have the system checked by an authorized dealer immediately.

Door Ajar

Sounds when the driver door is ajar, or when any door is ajar while the vehicle is travelling over 5 km/h.

Seatbelt Reminder

Sounds when a seatbelt is unfastened in an occupied seat and your vehicle is moving.

Instrument Cluster

Lane Departure Warning

Sounds when the system detects unintentional drifting toward the outside of the lane and alerts or aids you to stay in the lane through the steering system and instrument cluster display.

Front and Rear Park Aid

Sounds to alert driver of objects approaching the front and rear of the vehicle while moving forward or reversing.

Information Displays

GENERAL INFORMATION

WARNING



Driving while distracted can result in loss of vehicle control, crash and injury. We strongly recommend that you use extreme caution when using any device that may take your focus off the road. Your primary responsibility is the safe operation of your vehicle. We recommend against the use of any hand-held device while driving and encourage the use of voice-operated systems when possible. Make sure you are aware of all applicable local laws that may affect the use of electronic devices while driving.

You can control various systems on your vehicle using the information display controls on the steering wheel.

The information display shows the corresponding information.

Information Display

Type 1



E201432

Menu

You can access the menu using the information display control.

Note: *It may describe options not fitted to the vehicle you have purchased.*

Trip 1 and 2

Digital Speedometer

Distance to E

Trip odometer

Trip Timer

Fuel used

Average Fuel

Outside temp

All values

Note: *Press and hold OK on the current screen to reset the respective trip, distance, time and fuel information.*

Information Displays

Fuel Economy	
Distance to E	
Instantaneous Fuel	
Average Fuel	
Fuel History	
Average Speed	
All values	

Note: You can reset your average fuel economy by pressing and holding the OK button on the left hand steering wheel controls.

Driver Assist	
Traction Control	
Blindspot	
Cross Traffic	
Cruise Control	
Hill Start	
AdBlue® Stat.	
Intellig. AWD	
Front Park Aid	
Rear Park Aid	
Tire Monitor	Tire Pressure
Trailer Sway	

Settings		
Vehicle	Alarm	All Sensors
		Perim. Sens.
		Ask on exit

Information Displays

Settings			
A. Engine Off			
Chimes	Park Slot		
	Information		
DTE calculation	Normal		
	Towing		
Easy Entr/Ex			
Lighting	Auto Beam		
	A/lamp Dlay	Off	
		XX Seconds	
	DRL		
Locks	Auto lock		
	Auto unlock		
	Relock		
	Mislock		
	Unlocking	All Doors	
		Driver Door	
	Switches Inh.		
Power Mirror	Autofold		
Oil Life Reset	Hold OK to Reset Oil Life		
Park lock ctrl			
Pwr Lift Gate	Enable Swch		
	Disable Swch		
Seatbelts			
Silent Mode			
Windows	Remote Open		

Information Displays

Settings		
Display		Rmt Close
	Wipers	Crtesy wipe
		Rain Sensing
		Rev. Wiper
	Distance Unit	Miles & Gallons
		L/100km
		km/L
	Temper- ature	Fahrenh. (°F)
		Celsius (°C)
	Tire Pres- sure	psi
		kPa
		bar
Language	Choose your applicable setting	

Information Display

Type 2

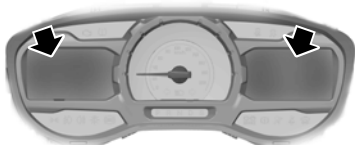

Menu

You can access the menu using the information display control.

Note: *It may describe options not fitted to the vehicle you have purchased.*

E201433

Information Displays

Trip 1 and 2	
All values	All Values — shows all trip values (Trip Timer, Odometer and Average Fuel).

Note: You can reset your trip information by pressing and holding the OK button on the left hand steering wheel controls.

Fuel Economy
Instant fuel
Fuel History
Average Speed

- Instant Fuel Economy - shows a visual graph of your instantaneous fuel economy.
- Fuel History - shows a bar chart of your fuel history.
- Average Speed - shows your vehicles average speed since the function was last reset.

Note: You can reset your average fuel economy by pressing and holding the OK button on the left hand steering wheel controls.

Driver Assist		
Traction Control		
Adaptive Steering	Steering in D	Sport
		Normal
	Steering in S	Sport
		Normal
Blindspot		
Cross Traffic Alert		
Cruise Control	Adaptive	
	Normal	
Driver Alert	Driver Alert	
	Display	
Hill Start		

Information Displays

Driver Assist		
AdBlue® Status		
Intelligent AWD		
Lane Keeping Sys	Mode	Alert Only
		Aid Only
		Both
	Intensity	High
		Normal
		Low
Front Park Aid		
Rear Park Aid		
Tire Monitor	Hold OK to Reset	
Trailer Sway		

Settings			
Vehicle	Alarm	All Sensors Active	
		Perimeter Sensing	
		Ask on Exit	
	Auto Engine Off		
	Chimes	Park Slot Found	
		Information	
	DTE Calculation	Normal	
		Towing	
	Easy Entry/Exit		
	Lighting	Auto Highbeam	
		Autolamp Delay	Off
			XX Seconds
		Daytime Lights	

Information Displays

Settings			
	Locks	Autolock	
		Autounlock	
		Relock	
		Mislock	
		Remote Unlock	All Doors
			Driver's Door
		Switch Inhibit	
	Mirrors	Autofold	
	Oil Life Reset	Hold OK to Reset	
	Park Lock Control		
	Power Liftgate	Enable Switch	
		Disable Switch	
	Seatbelts		
	Windows	Remote Open	
		Remote Close	
Wipers	Courtesy Wipe		
	Rain Sensing		
	Reverse Wiper		
Display Setup	Distance	Miles & Gallons	
		L/100km	
		Km/L	
	Temperature	°Fahrenheit	
		°Celsius	
	Tire Pressure	psi	
		kPa	
		bar	

Information Displays

Settings		
	Language	Choose your applicable setting
MyKey	{0} Admin Keys	"Num" MyKeys
		"Odo" MyKey km
		"Num" Admin Keys
		MyKey Dist
		Odo Units
	Create MyKey	-
	Traction Control	Always On
		Selectable
	Max Speed	Speed selectable based on Region
		Off
	Speed Minder	Speed selectable based on Region
		Off
	Volume Limiter	Set
	Clear MyKeys	Hold OK to
Clear MyKeys		

CLOCK

For detailed instructions on how to adjust the clock See **Audio Unit Clock and Date Displays** (page 242).

TRIP COMPUTER

Distance to Empty

Indicates the approximate distance your vehicle will travel on the fuel remaining in the tank. Changes in driving pattern may cause the value to vary.

Instantaneous fuel consumption

Indicates the current average fuel consumption.

Average Fuel Consumption

Indicates the average fuel consumption since the function was last reset.

Trip Odometer

Records the distance traveled on individual journeys.

Information Displays

Digital Speedometer

The speed your vehicle is traveling at will display as a digital number.

Average Speed

Indicates the average speed since the function was last reset.

Outside Air Temperature

Shows the outside air temperature.

Odometer

Records the total distance traveled by your vehicle.

Resetting the trip computer

To reset a particular display:

1. Highlight **Trip Computer** with the up and down arrow buttons and press the right arrow button.
2. Highlight the function to be reset.
3. Hold the **OK** button pressed.

PERSONALIZED SETTINGS

Languages

A selection of languages are available using the menus in the setting menu.

Measure units

To toggle between either metric or imperial units, scroll to this display and press the **OK** button.

Toggling the units of measure using this display will affect the following displays:

- Distance to empty.
- Average fuel consumption.
- Instantaneous fuel consumption.
- Average speed.

Temperature units

To toggle between metric and imperial units, scroll to this display and press the **OK** button.

Toggling the temperature units using this display will affect the following displays:

- Outside air temperature.
- The temperature display in the automatic climate control.

Chime deactivation

The following chimes can be switched off:

- Warning messages.
- Information messages.

MyKey

MyKey is a feature which allows customers to assign keys which will enable extra safety features designed for use by young drivers. Features can be adjusted and customized to suit the level of driver. Features include:

- Muted audio when seatbelts are unbuckled.
- Vehicle speed limited.
- Speed minder.
- Volume limiter on audio system.
- Fuel warnings given at higher distance to empty values.

Information Displays

- Prevention of turning off some driver assist systems:
 - Traction control
 - Park aid
 - Blind Spot monitor and cross traffic alert
 - Collision Warning System - additionally uses maximum sensitivity as default
 - Emergency assist
 - Do not disturb
- Mileage logged by MyKeys.



E201420

Press the OK button to acknowledge and remove some messages from the information display. Other messages will be removed automatically after a short time.

You need to confirm certain messages before you can access the menus.

INFORMATION MESSAGES

Note: Depending on the vehicle options equipped with your vehicle, not all of the messages will display or be available. Certain messages may be abbreviated or shortened depending upon which cluster type you have.

Active Park

Message	Action
Active Park Fault	Displayed when the system needs service. Contact your authorized dealer as soon as possible.

Information Displays

Adaptive Cruise Control

Message	Action
Adaptive Cruise Malfunction	Displayed when a radar malfunction is preventing the ACC from engaging. See Using Adaptive Cruise Control (page 147).
Adaptive Cruise Not Available	Displayed when conditions exist such that the adaptive cruise cannot function properly. See Using Adaptive Cruise Control (page 147).
Adaptive Cruise Not Available Sensor Blocked See Manual	Displayed when the radar is blocked because of poor radar visibility due to bad weather or ice/mud/water in front of radar. Driver can typically clean the sensor to resolve. See Using Adaptive Cruise Control (page 147).
Front Sensor Not Aligned	Displayed when a radar malfunction is preventing the ACC from engaging.
Adaptive Cruise - Driver Resume Control	Displayed when the adaptive cruise has reinstated controls to the driver.
Adaptive Cruise Speed Too Low to Activate	Displays when the vehicle speed is too slow to activate the adaptive cruise.
Adaptive Cruise Shift Down	Displays when the adaptive cruise is automatically adjusting the gap distance and the driver needs to shift the transmission into a lower gear.

Information Displays

AdBlue® Level

Message	Action
AdBlue® Low Range: XXXX km/mi Refill Soon	Indicates the approximate distance remaining before the diesel exhaust fluid (AdBlue®) tank will be empty. Refill the diesel exhaust fluid (AdBlue®) tank as soon as possible. See Selective Catalytic Reduction System (page 118).
AdBlue® Low No engine start in XXXX km/mi	Indicates the approximate distance remaining before the diesel exhaust fluid (AdBlue®) tank will be empty and when it will restrict the engine from starting. Refill the diesel exhaust fluid (AdBlue®) tank as soon as possible. See Selective Catalytic Reduction System (page 118).
AdBlue® level empty. Refill to start engine	The diesel exhaust fluid tank (AdBlue®) is empty and is restricting the engine from starting. Refill the diesel exhaust fluid (AdBlue®) tank.

AdBlue® System Malfunction

Message	Action
AdBlue® sys Fault Service req'd	The system has detected a fault that requires service.
AdBlue® sys Service req'd to start engine	The system has detected a fault that requires service.

Airbag

Message	Action
Occupant Sensor BLOCKED Remove Objects Near Passenger Seat	Displays when the system detects a malfunction due to a blocked sensor.

Information Displays

Alarm

Message	Action
Vehicle Alarm To Stop Alarm, Start Vehicle.	Displays when the alarm has been triggered due to unauthorized entry.

AWD

Message	Action
AWD Temporarily Disabled	Displayed when the AWD system has been temporarily disabled to protect itself from overheating.
AWD OFF	Displayed when the AWD system has been automatically disabled to protect itself. This is caused by operating the vehicle with the compact spare tire installed or if the system is overheating.
AWD Restored	The AWD system will resume normal function and clear this message after driving a short distance with the road tire re-installed or after the system is allowed to cool.
AWD Malfunction Service Required	Displayed in conjunction with the Throttle Control/Transmission/AWD light when the AWD system is not operating properly. If the warning stays on or continues to come on, contact your authorized dealer as soon as possible.

Information Displays

Battery and Charging System

Message	Action
Check Charging System	Displayed when the charging system needs servicing. If the warning stays on or continues to come on, contact your authorized dealer as soon as possible.
Low Battery Features Temporarily Turned Off	Displayed when the battery management system detects an extended low-voltage condition. Various vehicle features will be disabled to help preserve the battery. Turn off as many of the electrical loads as soon as possible to improve system voltage. If the system voltage has recovered, the disabled features will operate again as normal.
Turn Power Off To Save Battery	Displayed when the battery management system determines that the battery is at a low state of charge. Turn the ignition off as soon as possible to protect the battery. This message will clear once the vehicle has been started and the battery state of charge has recovered. Turning off unnecessary electrical loads will allow faster battery state-of-charge recovery.

Blind Spot Information and Cross Traffic Alert System

Message	Action
Blindspot System Fault	Displayed when a fault with the system has occurred. Contact your authorized dealer as soon as possible.
Blindspot Not Available Sensor Blocked See Manual	Displayed when the system sensors are blocked. Contact your authorized dealer as soon as possible. See Blind Spot Information System (page 159).
Vehicle Coming From Left	Displayed when the system detects a vehicle from the left side. See Blind Spot Information System (page 159).
Vehicle Coming From Right	Displayed when the system detects a vehicle from the right side. See Blind Spot Information System (page 159).
Cross Traffic Not Available Sensor Blocked See Manual	Displayed when the blind spot information system and cross traffic alert system sensors are blocked. See Blind Spot Information System (page 159).
Cross Traffic System Fault	Displays when a fault with the system has occurred. Contact your authorized dealer as soon as possible.

Information Displays

Doors and Locks

Message	Action
Door Ajar	Displays when the door(s) listed is not completely closed and the vehicle is moving.
	Displays when the door(s) listed is not completely closed.
Trunk Ajar	Displays when the luggage compartment is not completely closed.
Hood Ajar	Displays when the hood is not completely closed.
Switches Inhibited Security Mode	Displays when the door switches have been disabled.
Child Lock Malfunction Service Required	Displayed when there is a system malfunction with the child locks. Contact your authorized dealer as soon as possible.
Factory Keypad Code {X X X X}	Displays the factory keypad code after the keypad has been reset.

Driver Alert

Message	Action
Driver Alert Warning Rest Now	Stop and rest as soon as it is safe to do so.
Driver Alert Warning Rest Suggested	Take a rest break soon.

Fuel

Message	Action
Fuel Level Low	Displayed as an early reminder of a low fuel condition.
Check Fuel Fill Inlet	Displayed when the fuel fill inlet may not be properly closed.

Hill Start Assist

Message	Action
Hill Start Assist Not Available	Displays when hill start assist is not available. Contact your authorized dealer. See Hill Start Assist (page 130).

Information Displays

Hill Descent Control

Message	Action
For Hill Descent Reduce Speed 20MPH or Less	Displayed when vehicle speed is too high for HDC to engage. Reduce speed to below that indicated in the message to engage HDC.
Hill Descent Control Off System Cooling	Displayed when HDC cannot be engaged due to excessive heat. Allow system to cool before re-engaging.
Hill Descent Control Fault	Displayed when there is a fault with the HDC system. See your authorized dealer.
For Hill Descent Select Gear	Displayed when HDC cannot be engaged due to vehicle not being in gear. Select gear to engage HDC.

Keys and Keyless Entry

Message	Action
Starting System Fault	This message is displayed when there is a problem with your vehicle's starting system. See your authorized dealer for service.
To START Press Brake and Clutch	Displayed as a reminder to press the brake and clutch while starting the vehicle.
To START Press Clutch	Displayed as a reminder to press the clutch in while starting the vehicle.
Key Program Successful	Displayed during spare key programming, when an intelligent access key is programmed to the system.
Key Program Failure	Displayed during spare key programming, when an intelligent access key has failed to be programmed.
Max Number of Keys Learned	Displayed during spare key programming when the maximum number of keys have been programmed.
Not Enough Keys Learned	Displayed during spare key programming when not enough keys have been programmed.

Information Displays

Message	Action
Key Battery Low Replace Soon	Displays when the key battery is low. Change the battery as soon as possible.
Could Not Program Integrated Key	Displayed when an attempt is made to program a spare key using two existing keys.
Engine ON	Displays to inform the driver that they are exiting the vehicle and the engine is on.

Lane Keeping System

Message	Action
Lane Keeping Sys. Malfunction Service Required	The system has malfunctioned. Contact your authorized dealer as soon as possible.
Front Camera Temporarily Not Available	The system has detected a condition that has caused the system to be temporarily unavailable.
Front Camera Low Visibility Clean Screen	The system has detected a condition that requires the windshield to be cleaned to operate properly.
Front Camera Malfunction Service Required	The system has malfunctioned. Contact your authorized dealer as soon as possible.
Keep Hands on Steering Wheel	Displayed when the system requests the driver to keep their hands on the steering wheel.

Maintenance

Message	Action
Low Engine Oil Pressure	Stop the vehicle as soon as safely possible, turn off the engine. Check the oil level. If the warning stays on or continues to come on with your engine running, contact your authorized dealer as soon as possible.
Change Engine Oil Soon	Displayed when the engine oil life remaining is 10% or less. See Engine Oil Check (page 205).
Oil Change Required	Displayed when the oil life left reaches 0%. See Engine Oil Check (page 205).

Information Displays

Message	Action
Brake Fluid Level Low	Indicates the brake fluid level is low and the brake system should be inspected immediately. See Brake and Clutch Fluid Check (page 207).
Check Brake System	Displays when the brake system needs servicing. Stop the vehicle in a safe place. Contact your authorized dealer.
Engine Coolant Over Temperature	Displays when the engine temperature is too high. Stop the vehicle in a safe place and allow the engine to cool. If the problem persists, contact your authorized dealer. See Engine Coolant Check (page 205).
Power Reduced to Lower Engine Temp	Displays when the engine has reduced power in order to help reduce high coolant temperatures.
Transport Mode Contact Dealer	Displays to indicate that the vehicle is still in Transport mode. This may not allow some features to operate properly. See your authorized dealer.
Factory Mode Contact Dealer	Displays to indicate that the vehicle is still in Factory mode. This may not allow some features to operate properly. See your authorized dealer.
See Manual	Informs the driver that the powertrain needs service due to a powertrain malfunction.

Park Aid

Message	Action
Check Front Park Aid	Displays when the system has detected a condition that requires service. Contact your authorized dealer. See Front Parking Aid (page 139).
Check Rear Park Aid	Displays when the system has detected a condition that requires service. Contact your authorized dealer. See Rear Parking Aid (page 138).
Front Park Aid On Off	Displays the park aid status.
Rear Park Aid On Off	Displays the park aid status.

Information Displays

Park Brake

Message	Action
Park Brake Engaged	Displays when the parking brake is set, the engine is running and the vehicle is driven more than 5 km/h. If the warning stays on after the parking brake is released, contact your authorized dealer.

Power Steering

Message	Action
Steering Lock Fault Service Now	The power steering system has detected a condition that requires service. See your authorized dealer.
Steering Loss Stop Safely	The power steering system is not working. Stop the vehicle in a safe place. Contact your authorized dealer.
Steering Assist Fault Service Required	The power steering system has detected a condition within the power steering system or passive entry or passive start system requires service. Contact your authorized dealer.

Starting System

Message	Action
To START Press Brake	Displays when starting the vehicle as a reminder to apply the brake.
Engine Start Pending Please Wait	Displays when the starter is attempting to start the vehicle.
Pending Start Cancelled	Displays when the pending start has been cancelled.
Cranking Time Exceeded	Displays when the starter has exceeded its cranking time in attempting to start the vehicle.

Information Displays

Terrain Management System

Message	Action
Terrain Management System Fault	Displayed when there is a fault with the Terrain Management system. See your authorized dealer.
Mode Change Not Accepted, Retry	Displayed when the Terrain Management system was unable to complete a mode change. Retry to enter terrain modes.
To Enter Rock Mode 4x4 LOW is Required	Displayed when Terrain Management system is unable to enter crawl mode as the vehicle is not in AWD Low. Engage AWD Low to enter crawl mode.
To Exit 4x4 LOW Exit Rock Mode	Displayed when AWD Low cannot be disengaged as the Terrain Management is in crawl mode. Exit crawl mode to disengage AWD Low.

Tire Pressure Monitoring System

Message	Action
Tire Pressure Low	Displays when one or more tires on your vehicle have low tire pressure. See Tire Pressure Monitoring System (page 224).
Tire Pressure Monitor Fault	Displays when the tire pressure monitoring system is malfunctioning. If the warning stays on or continues to come on, contact your authorized dealer. See Tire Pressure Monitoring System (page 224).
Tire Pressure Sensor Fault	Displayed when a tire pressure sensor is malfunctioning, or your spare tire is in use. For more information on how the system operates under these conditions, See Tire Pressure Monitoring System (page 224). If the warning stays on or continues to come on, contact your authorized dealer as soon as possible.

Information Displays

Traction Control

Message	Action
Traction Control Off	Displays when the traction control system has been switched off. See Traction Control (page 133).
Traction Control On	Displays when the traction control system has been switched on. See Traction Control (page 133).
Spinout Detected Hazards Activated	Displays when a spinout has occurred and the hazard are activated.

Transmission

Message	Action
Transmission Malfunction Service Now	See your authorized dealer.
Transmission Overheating Stop Safely	The transmission is overheating and needs to cool. Stop in a safe place as soon as it is possible.
Transmission Service Required	See your authorized dealer.
Transmission Limited Function See Manual	Displays when the transmission has overheated and has limited functionality. See Automatic Transmission (page 124).
Transmission Not in Park	Displays as a reminder to shift into park.
Press Brake Pedal	Displays as a reminder to press the brake pedal in order to select a gear.

Powertrain

Message	Action
Check Locking Differential	Displayed when there is a malfunction with the electronic locking differential that requires service. See your authorized dealer.
Fuel Pressure Low	Displayed when there is a loss in fuel system pressure. See your authorized dealer.
Stop Safely Now	Displayed when there is a powertrain fault and vehicle has entered limp home mode. See your authorized dealer.

Information Displays

Trailer

Message	Action
Trailer Brake Module Fault	Displayed when there is a fault with the Trailer module. See your authorized dealer.
Fuel Pressure Low	Displayed when there is a loss in fuel system pressure. See your authorized dealer.
Stop Safely Now	Displayed when there is a powertrain fault and vehicle has entered limp home mode. See your authorized dealer.
Trailer Lighting Module Fault See Manual	Displayed when there is a fault with the Trailer module. See your authorized dealer.
Trailer Stop Lamps Fault Check Lamps	Displayed when there is a fault with the stop lamps on the trailer. Check Lamps.
Trailer Park Lamps Fault Check Lamps	Displayed when there is a fault with the park lamps on the trailer. Check Lamps.
Trailer Left Turn Lamps Fault Check Lamps	Displayed when there is a fault with the left lamps on the trailer. Check Lamps.
Trailer Right Turn Lamps Fault Check Lamps	Displayed when there is a fault with the right lamps on the trailer. Check Lamps.

Climate Control

PRINCIPLE OF OPERATION

Outside Air

Keep the air intakes in front of the windshield free from obstruction (such as snow or leaves) to allow the climate control system to function effectively.

Recirculated Air

WARNING



Prolonged use of recirculated air may cause the windows to mist up. If the windows mist up, follow the settings for demisting the windshield.

The air currently in the passenger compartment recirculates. Outside air does not enter your vehicle.

Heating

Heating performance depends on the temperature of the engine coolant.

General Information on Controlling the Interior Climate

Fully close all the windows.

Warming the Interior

Direct the air toward your feet. In cold or humid weather conditions, direct some of the air toward the windshield and the door windows.

Cooling the Interior

Direct the air toward your face.

Air Conditioning

The system directs air through the evaporator for cooling. The evaporator extracts humidity from the air to help keep the windows free of mist. The system directs the resulting condensation to the outside of your vehicle, which may cause a small pool to form under your vehicle. This is normal.

Note: The air conditioning operates only when the temperature is above 4°C.

Note: When you use air conditioning, your vehicle uses more fuel.

AIR VENTS

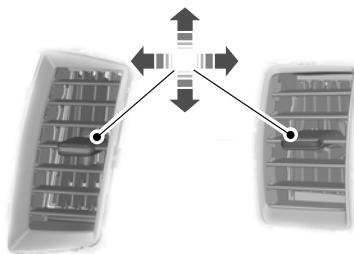

E201078

Climate Control

MANUAL CLIMATE CONTROL

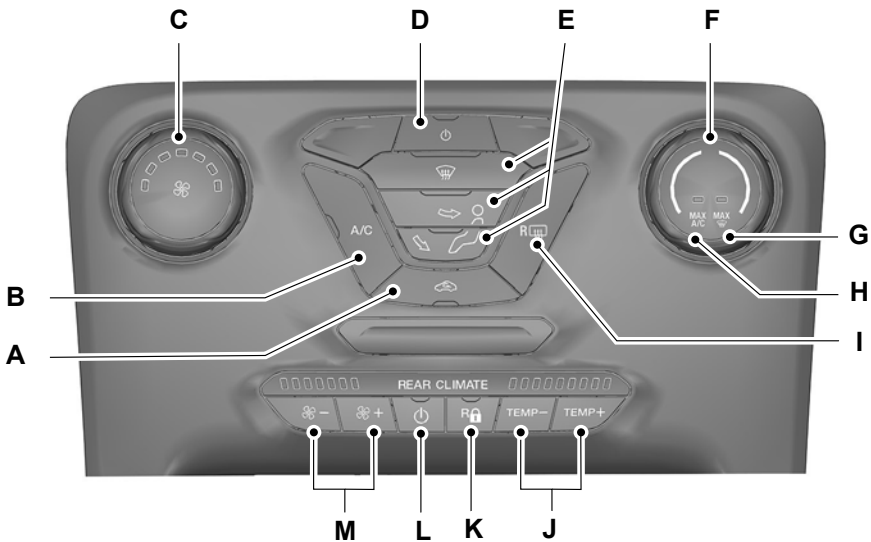

E200604

- A **Recirculated air:** Press the button to switch between outside air and recirculated air. The air currently in the passenger compartment recirculates. This can reduce the time needed to cool the interior (when used with A/C) and reduce unwanted odors from entering your vehicle.
- B **A/C:** Press the button to switch the air conditioning on or off. Air conditioning cools your vehicle.
Note: In certain conditions (for example, maximum defrost), the air conditioning compressor may continue to operate even though the air conditioning is switched off.
- C **Fan speed control:** Adjusts the volume of air circulated in the vehicle.
- D **Power:** Press the button to switch the system on and off.
- E **Air distribution control:** Press the buttons to turn airflow from the windshield, instrument panel, or footwell vents on or off. Some combinations cannot be selected.
Note: At least one of these buttons illuminates when the system is on.

Climate Control

- F **Temperature control:** Controls the temperature of the air circulated in the vehicle.
- G **MAX defrost:** Turn the temperature control dial all the way past the full heat position to maximise defrosting. Outside air flows through the windshield vents, air conditioning automatically turns on, fan automatically adjusts to the highest speed and temperature is set to the full heat position. You can also use this setting to defog or clear the windshield of a thin covering of ice. The heated rear window also automatically turns on when you select max defrost.
Note: To prevent window fogging, you cannot select recirculated air when defrost is on.
- H **MAX A/C:** Turn the temperature control dial all the way past the full cool position to maximise cooling. Recirculated air flows through the instrument panel vents, air conditioning automatically turns on, temperature is set to the full cool position and the fan adjusts to the highest speed.
- I **Heated rear window:** Press the button to switch the heated rear window on and off.
- J **Rear temperature control:** Adjust the temperature of the rear passenger compartment.
- K **Rear climate control lock:** Press the button to lock rear passenger climate control. Rear climate control cannot be operated if this is switched on.
- L **Rear climate control power:** Press the button to switch the rear system on and off.
- M **Rear fan speed control:** Adjust the volume of air circulated to the rear of the passenger compartment.

Climate Control

AUTOMATIC CLIMATE CONTROL

Type 1

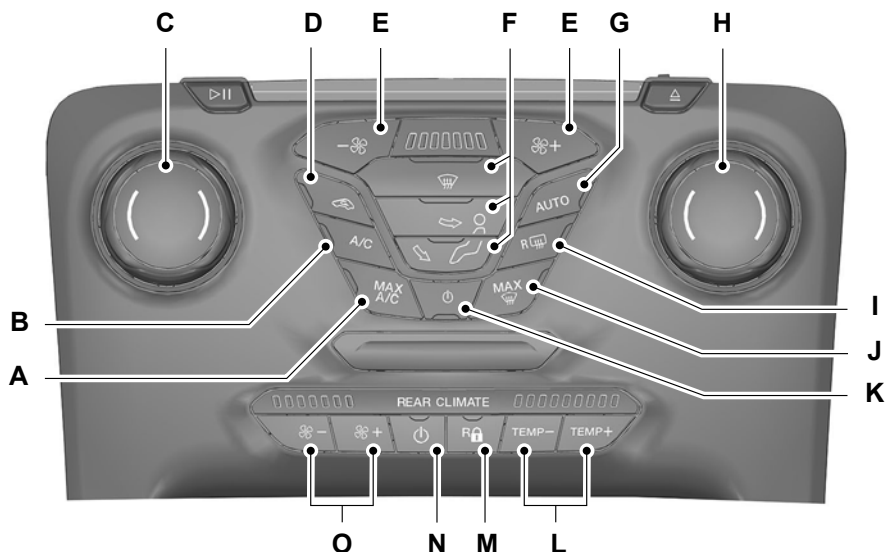

E200619

- A **MAX A/C:** Turn the temperature control dial all the way past the full cool position to maximise cooling. Recirculated air flows through the instrument panel vents, air conditioning automatically turns on, temperature is set to the full cool position and the fan adjusts to the highest speed.
- B **A/C:** Press the button to switch the air conditioning on or off. Air conditioning cools your vehicle.
Note: In certain conditions (for example, maximum defrost), the air conditioning compressor may continue to operate even though the air conditioning is switched off.
- C **Passenger temperature control:** Adjust the temperature on the passenger side of the vehicle. This also turns on dual zone mode.

Climate Control

- D Recirculated air:** Press the button to switch between outside air and recirculated air. The air currently in the passenger compartment recirculates. This can reduce the time needed to cool the interior and reduce unwanted odors from entering your vehicle.
- Note:** Recirculated air may also turn on and off automatically in instrument panel or instrument panel and floor airflow modes during hot weather to improve cooling efficiency.
- E Fan speed control:** Adjust the volume of air circulated in the vehicle.
- F Air distribution control:** Press the button to turn airflow from the windshield, instrument panel, or footwell vents on or off.
- Note:** At least one of these buttons illuminates when the system is on.
- G AUTO:** Press the button to switch on automatic operation. Adjust to select the desired temperature. The system adjusts the fan speed, air distribution, air conditioning operation, and outside or recirculated air to heat or cool the vehicle in order to maintain the desired temperature. You can also turn off dual zone mode by pressing and holding the button for greater than two seconds.
- H Driver temperature control:** Adjust the temperature setting using the control on the driver side. This control also adjusts the passenger side temperature when not in dual zone mode.
- I Heated rear window:** Press the button to switch the heated rear window on and off.
- J MAX Defrost:** Turn the temperature control dial all the way past the full heat position to maximise defrosting. Outside air flows through the windshield vents, air conditioning automatically turns on, fan automatically adjusts to the highest speed and temperature is set to the full heat position. You can also use this setting to defog or clear the windshield of a thin covering of ice. The heated rear window also automatically turns on when you select max defrost.
- Note:** To prevent window fogging, you cannot select recirculated air when defrost is on.
- K Power:** Press the button to switch the system on and off.
- L Rear temperature control:** Adjust the temperature of the rear passenger compartment.
- M Rear climate control lock:** Press the button to lock rear passenger climate control. Rear climate control cannot be operated if this is switched on.
- N Rear climate control power:** Press the button to switch the rear system on and off.
- O Rear fan speed control:** Adjust the volume of air circulated to the rear of the passenger compartment.

Climate Control

Type 2

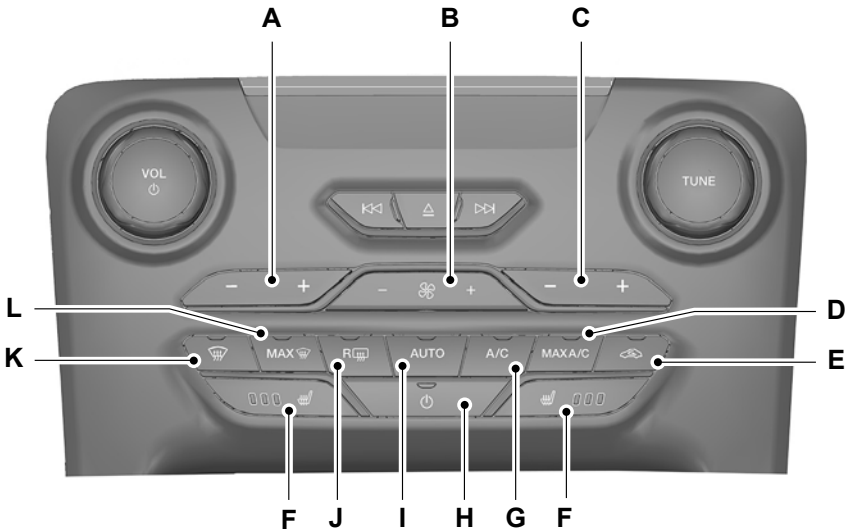

E200620

- A **Passenger temperature control:** Adjust the temperature on the passenger side. This also turns on dual zone mode.
 - B **Fan speed control:** Adjust the volume of air circulated in the vehicle.
 - C **Driver temperature control:** Adjust the temperature setting using the control on the driver side. This control also adjusts the passenger side temperature when not in dual zone mode.
 - D **MAX A/C:** Press the button. Recirculated air flows through the instrument panel vents, air conditioning automatically turns on, temperature is set to the full cool position and the fan adjusts to the highest speed.
 - E **Recirculated air:** Press the button to switch between outside air and recirculated air. The air currently in the passenger compartment recirculates. This can reduce the time needed to cool the interior and reduce unwanted odors from entering your vehicle.
- Note:** Recirculated air may also turn on and off automatically in instrument panel or instrument panel and floor airflow modes during hot weather to improve cooling efficiency.

Climate Control

- F **Heated seats:** Press the button to switch the heated seats on and off. See **Heated Seats** (page 108).
- G **A/C:** Press the button to switch the air conditioning on or off. Air conditioning cools your vehicle. To improve the time to reach a comfortable temperature in hot weather, drive with the windows open until you feel cold air through the air vents.
- Note:** In certain conditions (for example, maximum defrost), the air conditioning compressor may continue to operate even though the air conditioning is switched off.
- H **Power:** Press the button to switch the system on and off.
- I **AUTO:** Press the button to switch on automatic operation. Press the temperature control buttons to select the desired temperature. The system adjusts the fan speed, air distribution, air conditioning operation, and outside or recirculated air to heat or cool the vehicle in order to maintain the desired temperature. You can also turn off dual zone mode by pressing and holding the button for greater than two seconds.
- J **Heated rear window:** Press the button to switch the heated rear window on and off.
- K **Windshield defrost.** Press the button to redirect the air flow through windshield air vents.
- L **MAX Defrost:** Turn the temperature control dial all the way past the full heat position to maximise defrosting. Outside air flows through the windshield vents, air conditioning automatically turns on, fan automatically adjusts to the highest speed and temperature is set to the full heat position. You can also use this setting to defog or clear the windshield of a thin covering of ice. The heated rear window also automatically turns on when you select max defrost.

HINTS ON CONTROLLING THE INTERIOR CLIMATE

General Hints

WARNING



Prolonged use of recirculated air may cause the windows to fog up. If the windows fog up, follow the settings for demisting the windshield.

Note: You may feel a small amount of air from the footwell air vents regardless of the air distribution setting.

Note: To reduce humidity build-up inside your vehicle, do not drive with the system switched off or with recirculated air always switched on.

Note: Do not place objects under the front seats as this may interfere with the airflow to the rear seats.

Note: Remove any snow, ice or leaves from the air intake area at the base of the windshield.

Note: To improve the time to reach a comfortable temperature in hot weather, drive with the windows open until you feel cold air through the air vents.

Climate Control

Manual Climate Control

Note: To reduce fogging of the windshield during humid weather, adjust the air distribution control to the windshield air vents position.

Automatic Climate Control

Note: Adjusting the settings when your vehicle interior is extremely hot or cold is not necessary. The system automatically adjusts to heat or cool the interior to your selected temperature as quickly as possible. For the system to function efficiently, the instrument panel and side air vents should be fully open.

Note: If you select **AUTO** during cold outside temperatures, the system directs airflow to the windshield and side window vents. In addition, the fan may run at a slower speed until the engine warms up.

Note: If you select **AUTO** during hot outside temperatures, or when the inside of the vehicle is hot, the system automatically uses recirculated air to maximize interior cooling. When the interior reaches the selected temperature, the system automatically switches to using outside air.

Heating the Interior Quickly

	Vehicle with manual climate control	Vehicle with automatic climate control
1	Adjust the fan speed to a high speed setting.	Press the AUTO button.
2	Adjust the temperature control to the full heat setting.	Adjust the temperature control to the desired setting.
3	Select the footwell air vents using the air distribution buttons.	

Recommended Settings for Heating

	Vehicle with manual climate control	Vehicle with automatic climate control
1	Adjust the fan speed to the center setting.	Press the AUTO button.
2	Adjust the temperature control to the midway point of the hot settings.	Adjust the temperature control to the desired setting. Use 22°C as a starting point, then adjust the setting as necessary.
3	Select the footwell air vents using the air distribution buttons.	

Climate Control

Cooling the Interior Quickly

	Vehicle with manual climate control	Vehicle with automatic climate control
1	Adjust the temperature control to the MAX A/C position.	Press the MAX A/C button.
2	Drive with the windows fully open until you feel cold air through the air vents.	

Recommended Settings for Cooling

	Vehicle with manual climate control	Vehicle with automatic climate control
1	Adjust the fan speed to the center setting.	Press the AUTO button.
2	Adjust the temperature control to the midway point of the cold settings.	Adjust the temperature control to the desired setting. Use 22°C as a starting point, then adjust the setting as necessary.
3	Select the instrument panel air vents using the air distribution buttons.	

Side Window Defogging in Cold Weather

	Vehicle with manual climate control	Vehicle with automatic climate control
1	Select the windshield air vents using the air distribution buttons.	Press the defrost button.
2	Press the A/C button if the indicator is off.	Adjust the temperature control to the desired setting. Use 22°C as a starting point, then adjust the setting as necessary.
3	Adjust the temperature control to the desired setting.	
4	Adjust the fan speed to a high speed setting.	

Climate Control

REAR PASSENGER CLIMATE CONTROLS

Type 1

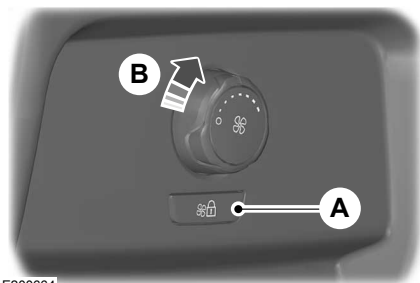

E200664

- A Rear climate control lock indicator.
- B **Fan speed control:** Adjust the volume of air circulated.

Type 2

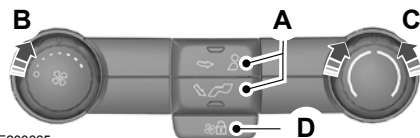

E200665

- A **Air distribution control:** Press the button to change the airflow direction.
- B **Fan speed control:** Adjust the volume of air circulated.
- C **Temperature control:** Controls the temperature of the air circulated.
- D Rear climate control lock indicator.

Note: The rear climate control lock indicator illuminates when rear climate control is locked using front climate control.

HEATED WINDOWS AND MIRRORS

Note: Make sure the engine is running before operating the heated windows.

Heated Windshield



Press the button to clear the window of thin ice and fog.

Heated Rear Window



Press the button to clear the window of thin ice and fog. Press the button to switch the system off. The heated rear window will automatically turn off after a short period of time.

Note: Do not use razor blades or other sharp objects to clean the inside of the rear window or to remove decals from the inside of the rear window. This may cause damage to the heated grid lines and will not be covered by your warranty.

Heated Exterior Mirror

Note: Do not remove ice from the mirrors with a scraper or attempt to readjust the mirror glass if it is frozen in place. These actions could cause damage to the glass and mirrors.

Note: Do not clean the housing or glass of any mirror with harsh abrasives, fuel or other petroleum-based cleaning products.

Both mirrors are heated to remove ice, mist and fog when the heated rear window is switched on.

Climate Control

CABIN AIR FILTER

Your vehicle cabin air filter gives you and your passengers the following benefits:

- It improves your driving comfort by reducing particle concentration.
- It improves the interior compartment cleanliness.
- It protects the climate control components from particle deposits.
- It reduces unpleasant odor and pollutants (vehicles fitted with odor filter).

The cabin air filter is behind the glove box.

Replace the filter at regular intervals.

Make sure you have a cabin air filter installed at all times.

This prevents foreign objects from entering the system.

Running the system without a filter in place could degrade or damage the system.

Seats

SITTING IN THE CORRECT POSITION

WARNINGS



Sitting improperly, out of position or with the seatback reclined too far can take weight off the seat cushion and affect the decision of the passenger sensing system, resulting in serious injury or death in the event of a crash. Always sit upright against your seatback, with your feet on the floor.



Do not recline the seatback as this can cause the occupant to slide under the seatbelt, resulting in serious injury in the event of a crash.



Do not place objects higher than the seatback to reduce the risk of serious injury in the event of a crash or during heavy braking.

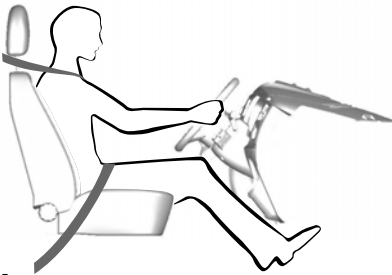

E68595

When you use them properly, the seat, head restraint, seatbelt and airbags will provide optimum protection in the event of a crash.

We recommend that you follow these guidelines:

- Sit in an upright position with the base of your spine as far back as possible.
- Do not recline the seatback more than 30 degrees.
- Adjust the head restraint so that the top of it is level with the top of your head and as far forward as possible. Make sure that you remain comfortable.
- Keep sufficient distance between yourself and the steering wheel. We recommend a minimum of 25 cm between your breastbone and the airbag cover.
- Hold the steering wheel with your arms slightly bent.
- Bend your legs slightly so that you can press the pedals fully.
- Position the shoulder strap of the seatbelt over the center of your shoulder and position the lap strap tightly across your hips.

Make sure that your driving position is comfortable and that you can maintain full control of your vehicle.

HEAD RESTRAINTS

WARNINGS



Fully adjust the head restraint before you sit in or operate your vehicle. This will help minimize the risk of neck injury in the event of a crash. Do not adjust the head restraint when your vehicle is moving.



Raise the rear head restraints when passengers occupy the rear seats.



When front seats are in use the head restraints must not be removed.

Seats

Front head restraints

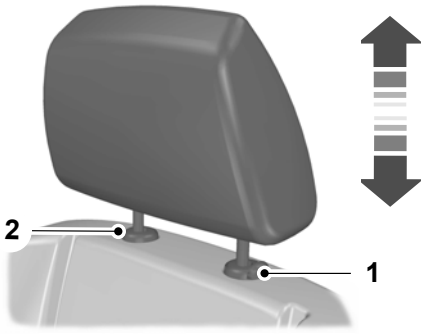

E140447

To raise, pull the head restraint up to the desired position. To lower, press locking button 1 and lower the head restraint to the desired position. Make sure that the head restraint engages properly when in position.

The head restraint should be located so that the top of the head restraint is level with the top of your head for optimum support in the event of an impact.

To remove the head restraint

Press locking button 1 and at the same time release the retaining clip 2 using a suitable implement.

Rear head restraints (Second row seats)

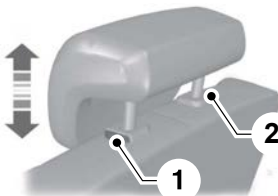

E212698

To raise, pull the head restraint up to the fullest extent. Press the locking button 1 to lower the head restraint. Press the locking button 2 to remove the head restraint.

Rear head restraints (Third row seats)

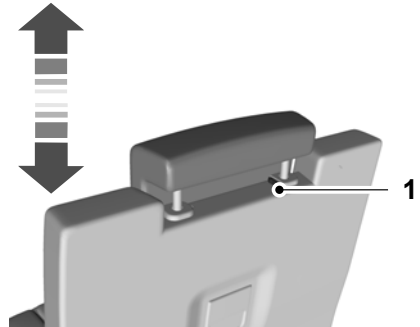

E213753

To raise, pull the head restraint up to the fullest extent where it will lock into position. To lower, press the locking button 1 and push the head restraint downward. To remove, raise the head restraint to the locked position, press the locking button 1 and pull the head restraint upward, removing it from the seat back.

MANUAL SEATS

WARNING



Do not adjust the driver seat when your vehicle is moving.

Seats

Moving the Seat Backward and Forward



E201041

WARNING



Make sure the seat fully locks into place by rocking it backward and forward.

Adjusting the Height of the Driver Seat

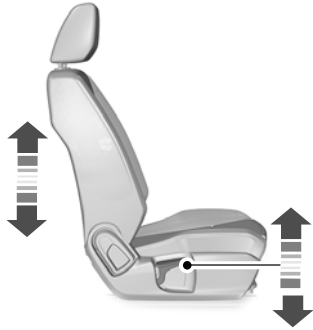

E201043

Recline Adjustment

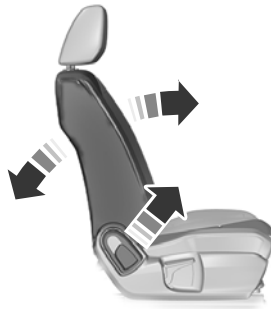

E201044

Seats

WARNING

 Do not place cargo or any objects behind the seat backrest before returning it to the original position. Pull on the seat backrest to make sure that it has fully latched after returning the seat backrest to its original position. An unlatched seat may become dangerous if you stop suddenly or have a crash.

Adjusting the Lumbar Support of the Driver Seat

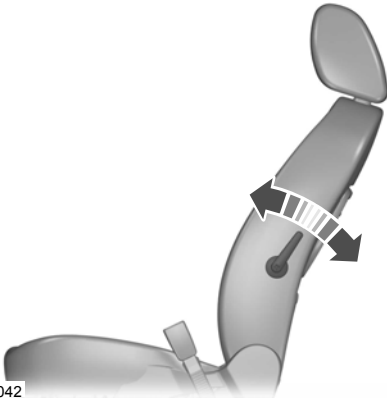

E201042

POWER SEATS (If Equipped)

WARNINGS

 Do not adjust the driver's seat or seatback when your vehicle is moving. Adjusting your seatback while your vehicle is in motion may cause loss of control of your vehicle.

 Do not place cargo or any objects behind the seatback before returning it to the original position.

Seats

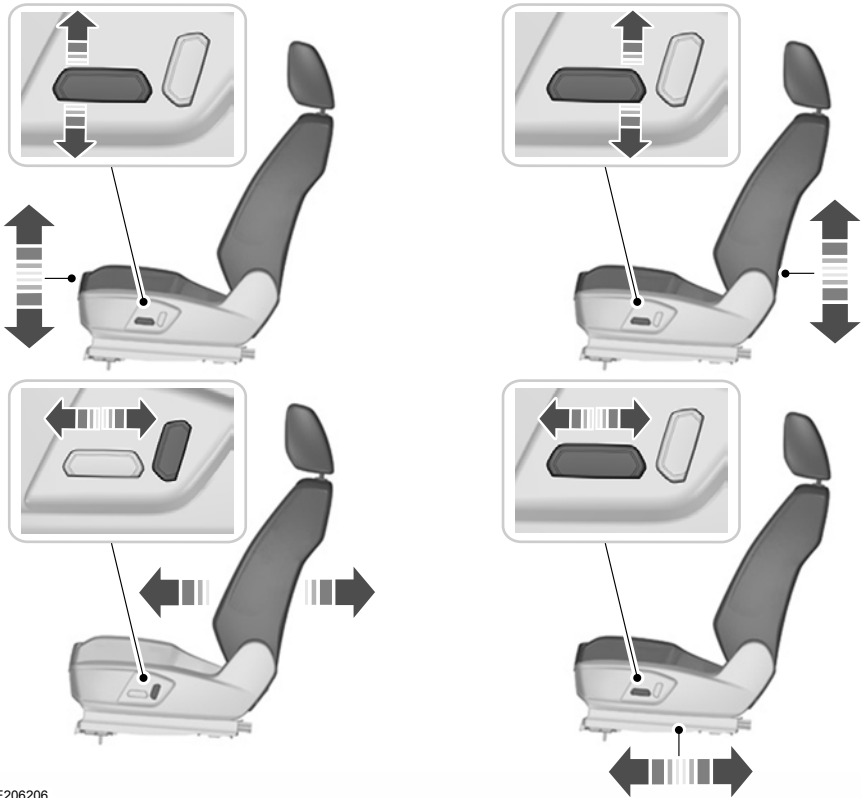

E206206

REAR SEATS

Adjusting the Rear Seats

Second Row Seats

WARNINGS



Always drive and ride with your seatback upright and the lap belt snug and low across the hips.

WARNINGS



Reclining the seatback can cause an occupant to slide under the seat's seatbelt, resulting in severe personal injuries in the event of a crash.

Seats

Reclining adjustment

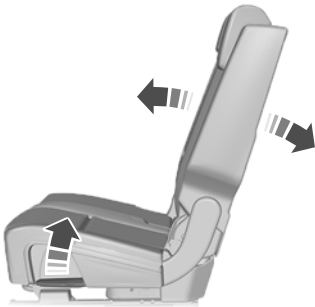

E201038

Folding the Seatback

WARNING



When folding the seatbacks down, take care not to get your fingers caught between the seatback and seat frame.



E206205

With the seat empty, pull the lever up to fold the seatback forward.

Note: Lower the head restraints. See **Head Restraints** (page 100).

Moving the Seats Backward and Forward (If equipped)

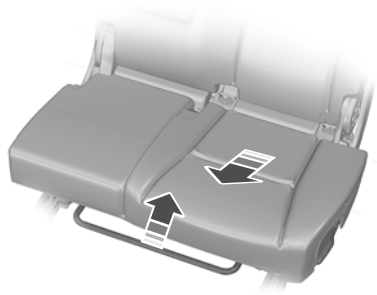

E201070

Accessing Third Row Seats

WARNING



Before returning the seatback to its original position, make sure that cargo or any objects are not trapped behind the seatback. After returning the seatback to its original position, pull on the seatback to make sure that it has fully latched. An unlatched seat may become dangerous in the event of a sudden stop or crash.

Note: Remove items from the second-row seat. Make sure that no bulky objects such as purses or briefcases are on the floor in front of the second-row seats before folding the seats to easy entry position.

Note: For second-row bench seats, make sure the center seatbelt is unbuckled before folding the seatback.

Note: You may have to move the front-row seat forward to allow the second-row seat to be fully folded.

Seats

Note: You may have to lower the center head restraint. See **Head Restraints** (page 100).

Fold the second-row seat to access the third row:

1. Fold the outboard head restraint. See **Head Restraints** (page 100).



E206205

2. Pull the handle located on the top of the seat to move the seats to easy entry position to access 3rd row.
3. Move the left side seat forward until it releases from the catch.
- 4.
5. Lift the seatback toward the rear of the vehicle, and rotate the seatback until you hear a click, locking it in the upright position.



E190846

6. Pull the head restraint back up to its normal adjusted position.

Folding and unfolding the Third Row Manual Seat

1. Remove all objects from the seat.
2. Lower all third row head restraints. See **Head Restraints** (page 100).

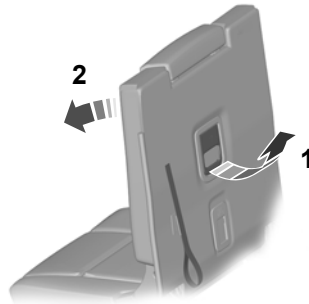

E201039

3. From the rear of the vehicle, fold the seatback by pulling and holding the handle while pushing the seatback forward. Release the handle once the seatback starts rotating forward.
4. To return the seatback to the upright position, pull the long strap located on the seatback.

Seats

Note: Do not use the seat anchors as cargo tie downs.



E190924

Note: Make sure that the area under the seat is free of objects before stowing it.

PowerFold™ Third Row Seats (If equipped)

The third row power seat buttons are located behind the third row seats on the left-hand quarter trim panel.

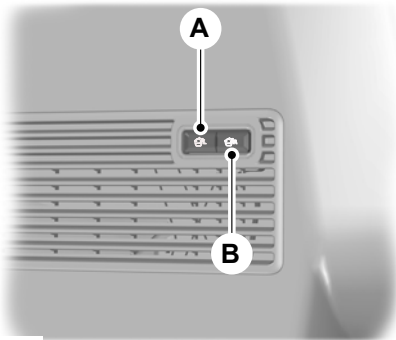

E206212

- A Press to fold and unfold left hand side seat.
- B Press to fold and unfold right hand side seat.

Note: The third row seat includes obstacle detection that allows the seat to stop and reverse direction if it hits an obstacle so that the obstacle can be removed.

Note: Pressing a different button while the power seat feature is already being performed may cause the first selected seat movement to be cancelled. Allow the first seat movement to be completed before pressing a button for another function.

Note: Make sure that there are no objects such as books, purses or briefcases on the load floor before unstowing the seat. Failure to remove all objects from the top of the load floor prior to unstowing it may cause damage to the seat.

Note: In order to allow the seat to complete the stowed position, do not place objects under the seat before stowing. Remove all objects from the seat and stowage tub.

Note: In the unlikely event that the third row power seat stops prematurely or travels to an unexpected position, press the FOLD button to reset the seat and return it to a normal position.

These seats feature a power one-touch operation that allows you fold and stow the seats.

- The power fold seats work only when the transmission is in park (P) and the liftgate is open.
- If the ignition is off and the feature is still running, the battery saver will turn it off after 10 minutes. Press unlock on the remote entry key transmitter to reactivate the power seats or unlock it with the keyless entry keypad. See **Remote Control** (page 26).

HEATED SEATS (If Equipped)

Front Seats

WARNING



People who are unable to feel pain to their skin because of advanced age, chronic illness, diabetes, spinal cord injury, medication, alcohol use, exhaustion or other physical conditions, must exercise care when using the heated seat. The heated seat may cause burns even at low temperatures, especially if used for long periods of time. Do not place anything on the seat that insulates against heat, such as a blanket or cushion. This may cause the heated seat to overheat. Do not puncture the seat with pins, needles or other pointed objects. This may damage the heating element which may cause the heated seat to overheat. An overheated seat may cause serious personal injury.

Do not do the following:

- Place heavy objects on the seat.
- Operate the heated seat if water or any other liquid spills on the seat. Allow the seat to dry thoroughly.
- Operate the heated seats unless the engine is running. Doing so can cause the battery to lose charge.



E146322

Press the heated seat symbol to cycle through the various heat settings and off. More indicator lights indicate warmer settings.

Auxiliary Power Points

12 Volt DC Power Point

WARNING



Incorrect use of the 12 Volt DC Power Point can cause damage not covered by your warranty, and can result in fire or serious injury.

Note: *If used when the vehicle is not running, the battery will run out of charge. There may be insufficient power to restart your vehicle.*

Note: *When you switch the ignition on, you can use the socket to power 12 volt appliances with a maximum current rating of 15 amps.*

After you switch the ignition off, the power supply works only for a maximum of 75 minutes.

Note: *Do not insert objects other than an accessory plug into the power point. This damages the outlet and blows the fuse.*

Note: *Do not hang any type of accessory or accessory bracket from the plug.*

Note: *Do not use the power point over the vehicle capacity of 12 volt DC 150 watt or a fuse may blow.*

Note: *Incorrect use of the power point can cause damage not covered by your warranty.*

Note: *Always keep the power point caps closed when not in use.*

Run the engine for full capacity use of the power point.

To prevent the battery from running out of charge:

- Do not use the power point longer than necessary when your engine is not running.
- Do not leave devices plugged in overnight or when your vehicle is in park (P) for extended periods.

Locations

Power points may be in the following locations:

- On the instrument panel above the cup holders.
- On the rear of the center console.
- In the rear cargo area.

AC Power Point

WARNING



Do not keep electrical devices plugged in the power point whenever the device is not in use. Do not use any extension cord with the 230 volt or 110 volt AC power point, since it will defeat the safety protection design. Doing so may cause the power point to overload. Powering multiple devices can reach beyond the 150 watt load limit and could result in fire or serious injury.

Note: *Keep the vehicle running to use the power point.*

Note: *Depending on your vehicle, the power point may open to the right or upward.*

Note: *Depending on your vehicle, the power point may provide 230 volt AC power, or 110 volt AC power.*

With the engine off, the power point works up to maximum 75 minutes (or less). The power point turns off automatically if the battery voltage becomes low. This prevents the vehicle battery from running out of charge.

Auxiliary Power Points

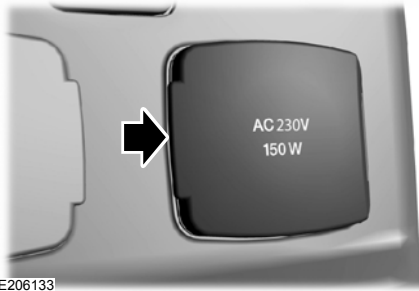

E206133

You can use the power point for powering electrical devices that require up to 150 watts. It is on the rear of the center console.

The power point indicator light, located on the power point, shows when the power point is ready for use.

When the power point indicator light is:

- On — the power point is ready to supply power.
- Off — the power point power supply is off and so is the ignition.
- Flashing — the power point is in fault mode, or the battery voltage is too low.

The power outlet temporarily turns off power when in fault mode if the device exceeds the 150 watt limit. Unplug your device and switch the ignition off. Switch the ignition back on, but do not plug your device back in. Let the system cool off and switch the ignition off to reset the fault mode. Switch the ignition back on and make sure the indicator light remains on.

Do not use the power point for certain electric devices, including:

- Cathode-ray, tube-type televisions.
- Motor loads, such as vacuum cleaners, electric saws and other electric power tools or compressor-driven refrigerators.

- Measuring devices, which process precise data, such as medical equipment or measuring equipment.
- Other appliances requiring an extremely stable power supply such as microcomputer-controlled electric blankets or touch-sensor lamps.

Storage Compartments

CUP HOLDERS

WARNING



Use only soft cups in the cup holders. Hard objects can injure you in a crash.

Note: Stow items in the cup holder carefully as items may become loose during hard braking, acceleration or crashes, including hot drinks which may spill.

Depending on your vehicle, cup holders may be located in the centre console for first row occupants, in the centre fold down seat for second row occupants and in the outer side trims for third row occupants.

GLOVE BOX

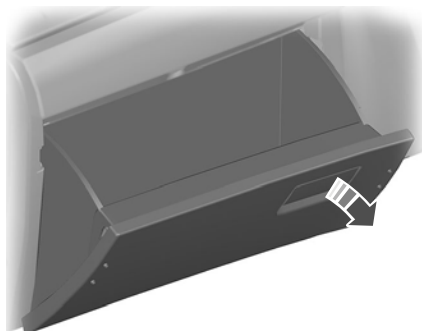

E136461

Note: When opening the glove box, allowing the glove box dampener to lower it gently until it comes to rest.

The glove box is located on the passenger side of the instrument panel. The glove box is opened using the latch handle.

Glove box with key

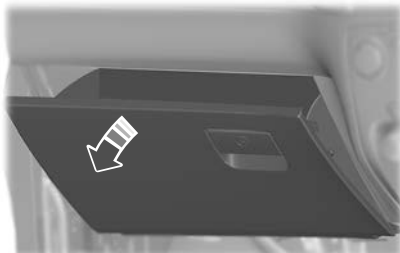

E206091

The glove box can be locked using the ignition key. To lock, close the glove box, then insert the ignition key into the glove box lock and rotate it clockwise. Remove the key.

To unlock the glove box, insert the ignition key into the glove box lock and rotate it counter clockwise. The glove box will then open as normal using the latch handle.

CENTER CONSOLE

Stow items in the cup holder carefully as items may become loose during hard braking, acceleration or crashes, including hot drinks which may spill.

Available console features include:

- Front Cup Holders. See **Cup Holders** (page 111).
- Auxiliary Power Points. See **Auxiliary Power Points** (page 109).
- Media Hub See **Media Hub** (page 246).

Storage Compartments

Center Console Armrest

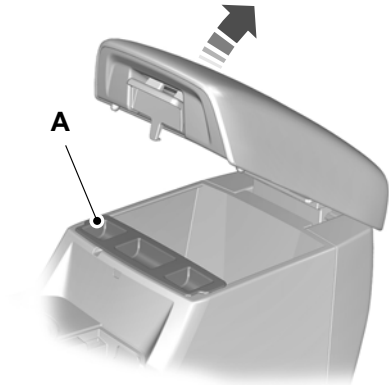

E205766

A Coin tray.

OVERHEAD CONSOLE

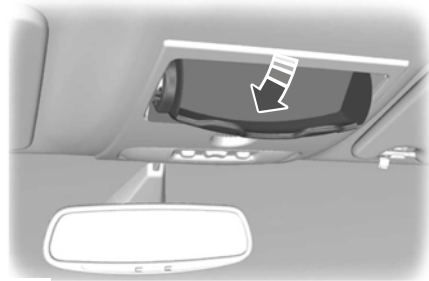

E75193

Press near the rear edge of the door to open it.

Starting and Stopping the Engine

GENERAL INFORMATION

WARNINGS

 Extended idling at high engine speeds can produce very high temperatures in the engine and exhaust system, creating the risk of fire or other damage.

 Do not park, idle or drive your vehicle on dry grass or other dry ground cover. The emission system heats up the engine compartment and exhaust system, creating the risk of fire.

 Do not start the engine in a closed garage or in other enclosed areas. Exhaust fumes can be toxic. Always open the garage door before you start the engine.

 If you smell exhaust fumes inside your vehicle, have it checked by a Ford Dealer immediately. Do not drive your vehicle if you smell exhaust fumes.

If you disconnect the battery, your vehicle may exhibit some unusual driving characteristics for approximately 10 km after you reconnect it. This is because the engine management system must realign itself with the engine. You can disregard any unusual driving characteristics during this period.

When you start the engine, avoid pressing the accelerator pedal before and during operation. Only use the accelerator pedal when you have difficulty starting the engine.

IGNITION SWITCH



E72128

Note: Make sure the key is clean before inserting it into any lock cylinder.

0 (off) - The ignition is off.

I (accessory) - Allows the electrical accessories to operate while the engine is not running.

Note: Do not leave the ignition key in this position for too long to avoid your vehicle battery losing charge.

II (on) - All the electrical circuits are operational. Warning lamps and indicators illuminate.

III (start) - cranks the engine. Release the key as soon as the engine starts.

STEERING WHEEL LOCK

WARNING

 Always check that the steering wheel lock is deactivated before attempting to move your vehicle. Failure to deactivate the steering wheel lock could result in a crash.

To lock the steering wheel:

1. Remove the key from the ignition switch.
2. Rotate the steering wheel slightly to engage the lock.

Starting and Stopping the Engine

Unlocking the Steering Wheel

Vehicles With Automatic Transmission

Switch the ignition on or press the brake pedal.

Vehicles With Manual Transmission

Switch the ignition on.

STARTING A DIESEL ENGINE

Cold or Hot Engine

All Vehicles

Note: *When the temperature is below -15°C, you may need to crank the engine for up to 10 seconds.*

Note: *You can only operate the starter for a limited period of time.*

Note: *After a limited number of attempts to start your engine, the system will not allow you to try again until a period of time has elapsed, for example 30 minutes.*



Switch the ignition on and wait until the glow plug indicator goes off.

Vehicles With Manual Transmission

Note: *Do not touch the accelerator pedal.*

Note: *Releasing the clutch pedal while the engine is starting will stop the engine cranking and return to ignition on.*

1. Fully depress the clutch pedal.
2. Start the engine.

Vehicles With Automatic Transmission

Note: *Do not touch the accelerator pedal.*

Note: *Releasing the brake pedal while the engine is starting will stop the engine cranking and return to ignition on.*

1. Move the transmission selector lever to position park (P) or neutral (N).
2. Fully depress the brake pedal.
3. Start the engine.

Failure to Start

Vehicles With Manual Transmission

If the engine does not crank when the clutch pedal has been fully depressed and the ignition key is turned to position **III**.

1. Fully depress the clutch and brake pedals.
2. Turn the key to position **III** until the engine has started.

DIESEL PARTICULATE FILTER

The filter forms part of the emissions reduction system on your vehicle. It filters harmful diesel particulates (soot) from the exhaust gas.

Regeneration

WARNING



Do not park or idle your vehicle over dry leaves, dry grass or other combustible materials. The regeneration process creates very high exhaust gas temperatures and the exhaust will radiate a considerable amount of heat during and after regeneration and after you have switched the engine off. This is a potential fire hazard.

Note: *Avoid running out of fuel.*

Note: *During regeneration at low speed or engine idle, you may smell a hot metallic odor and could notice a clicking metallic sound. This is due to the high temperatures reached during regeneration and is normal.*

Starting and Stopping the Engine

Note: Changes in the engine or exhaust sound may be heard during the regeneration process.

Note: After you have switched your engine off the fans may continue to run for a short period of time.

The diesel particulate filter on your vehicle requires periodic regeneration to maintain its correct function. Your vehicle will carry out this process automatically.

If your journeys meet one of the following conditions:

- You drive only short distances.
- You frequently switch the ignition on and off.
- Your journeys contain a high level of acceleration and deceleration.

You must carry out occasional trips with the following conditions to assist the regeneration process:

- Drive your vehicle in more favorable conditions, which you will find at higher vehicle speeds in normal driving, on a main road or freeway for a minimum of 20 minutes. This drive may include short stops that will not affect the regeneration process.
- Avoid prolonged idling and always observe speed limits and road conditions.
- Do not switch the ignition off.
- Select a suitable gear to ideally maintain engine speed between 1500 and 3000 RPM.

SWITCHING OFF THE ENGINE

Vehicles With a Turbocharger

WARNING



Do not switch the engine off when it is running at high speed. If you do, the turbocharger will continue running after the engine oil pressure has dropped to zero. This will lead to premature turbocharger bearing wear.

Release the accelerator pedal. Wait until the engine has reached idle speed and then switch it off.

Fuel and Refueling

SAFETY PRECAUTIONS

WARNINGS



Do not overfill the fuel tank. The pressure in an overfilled tank may cause leakage and lead to fuel spray and fire.



Automotive fuels can cause serious injury or death if misused or mishandled.



Flow of fuel through a fuel pump nozzle can produce static electricity. This can cause a fire if you are filling an ungrounded fuel container.



Fuel ethanol and gasoline may contain benzene, which is a cancer-causing agent.



When refueling always shut the engine off and never allow sparks or open flames near the filler neck. Never smoke or use a cell phone while refueling. Fuel vapor is extremely hazardous under certain conditions. Avoid inhaling excess fumes.

Observe the following guidelines when handling automotive fuel:

- Extinguish all smoking materials and any open flames before refueling your vehicle.
- Always turn off the vehicle before refueling.
- Automotive fuels can be harmful or fatal if swallowed. Fuel such as gasoline is highly toxic and if swallowed can cause death or permanent injury. If fuel is swallowed, call a physician immediately, even if no symptoms are immediately apparent. The toxic effects of fuel may not be visible for hours.

- Avoid inhaling fuel vapors. Inhaling too much fuel vapor of any kind can lead to eye and respiratory tract irritation. In severe cases, excessive or prolonged breathing of fuel vapor can cause serious illness and permanent injury.
- Avoid getting fuel liquid in your eyes. If fuel is splashed in the eyes, remove contact lenses (if worn), flush with water for 15 minutes and seek medical attention. Failure to seek proper medical attention could lead to permanent injury.
- Fuels can also be harmful if absorbed through the skin. If fuel is splashed on the skin, clothing or both, promptly remove contaminated clothing and wash skin thoroughly with soap and water. Repeated or prolonged skin contact with fuel liquid or vapor causes skin irritation.
- Be particularly careful if you are taking "Antabuse" or other forms of disulfiram for the treatment of alcoholism. Breathing gasoline vapors, or skin contact could cause an adverse reaction. In sensitive individuals, serious personal injury or sickness may result. If fuel is splashed on the skin, promptly wash skin thoroughly with soap and water. Consult a physician immediately if you experience an adverse reaction.

FUEL QUALITY

WARNINGS



Do not mix diesel with oil, gasoline or other liquids. This could cause a chemical reaction.



Do not add kerosene, paraffin or gasoline to diesel. This could cause damage to the fuel system.

Note: We recommend that you use only high quality fuel.

Fuel and Refueling

Note: We do not recommend the use of additional additives or other engine treatments for normal vehicle use.

Note: We do not recommend the use of additional additives to prevent fuel waxing.

Biodiesel Usage

WARNING



Do not use raw oils, fats or waste cooking greases, these are not biodiesel.

Your vehicle is suitable for use with biodiesel blends up to 10% (B10). You can achieve acceptable engine performance and durability using B10 by adhering to below guidelines.

Note: Use diesel fuel that meets the equivalent specification defined by EN 590 or the relevant national specification, from a trusted fuel supplier

Note: If your vehicle experiences low temperature fuel waxing issues, consider using different diesel brands or diesel with lower biodiesel content.

Long-Term Storage

Most diesel fuels contain biodiesel. Do not leave vehicles filled with B10 fuels parked for more than 1 month. Diesel fuels containing biodiesel can degrade quickly when stored for long periods of time, especially when exposed to warm and humid conditions. Alternatively, we recommend that you seek advice from your dealer.

Diesel-Winter Driving

Diesel fuel purchased in the city and coastal regions often has different cold temperature properties than diesel sold in Alpine regions. Wax may form in the fuel lines in the vehicles left outside in below zero temperature for a longer time. This

means that the vehicle will not start or run correctly until the wax has melted. To avoid this problem, if a prolonged or overnight stay is planned in an alpine region then it is strongly recommended that the vehicle carry enough fuel to get to the Alpine region and is then refuelled locally so that at least 50% of the fuel volume is Alpine mix diesel. At the time of publication, Alpine mix diesel is available at the following BP service stations: **Victoria** Bright, Corryong and Mansfield **NSW** Jindabyne, Thredbo, Tumut, Talbingo, Adaminaby and Cooma. Please confirm current availability at the time of your trip.

RUNNING OUT OF FUEL

Avoid running out of fuel. This may have an adverse effect on powertrain components.

If you have run out of fuel:

- You may need to cycle the ignition from off to on several times after refuelling to allow the fuel system to pump the fuel from the tank to the engine. On restarting, cranking time will take a few seconds longer than normal. Crank time will be longer than usual.
- Normally, adding 4 L of fuel is enough to restart the engine. If the vehicle is out of fuel and on a steep grade, more than 4 L may be required.

Fuel Run Dry Protection Feature

Your vehicle is fitted with a fuel run dry protection system to prevent engine damage.

The vehicle will enter an engine misfire mode and shutdown at a pre determined distance after the **Distance to Empty** becomes zero.

Refill the fuel tank with a minimum of 4 L diesel before resetting the feature.

Fuel and Refueling

Reset the fuel run dry protection feature by following the below steps:

1. Insert the ignition key and turn to position **II** (Ignition).
2. Hold the key in the position for 20 seconds and turn back to **O** (Off).
3. Repeat the steps three times to complete the reset procedure.

Filling a Portable Fuel Container

Use the following guidelines to avoid electrostatic charge build-up when filling an ungrounded fuel container:

- Only use an approved fuel container to transfer fuel to your vehicle. Place the container on the ground when filling.
- Do not fill a fuel container while it is inside your vehicle (including the cargo area).
- Keep the fuel pump nozzle in contact with the fuel container while filling.
- Do not use a device that holds the fuel pump nozzle lever in the fill position.



CATALYTIC CONVERTER

WARNING



 Do not park or idle your vehicle over dry leaves, dry grass or other combustible materials. The exhaust will radiate a considerable amount of heat during use, and after you have switched the engine off. This is a potential fire hazard.

Driving with a Catalytic Converter

WARNINGS





-  Avoid running out of fuel.
-  Do not crank the engine for long periods.

WARNINGS

-  Do not run the engine when a spark plug lead is disconnected.
-  Do not push-start or tow-start your vehicle. Use booster cables. See **Jump Starting the Vehicle** (page 184).
-  Do not switch the ignition off when driving.

SELECTIVE CATALYTIC REDUCTION SYSTEM

WARNINGS

-  The engine may not start if you tamper with or disable the selective catalytic reduction system.
-  The engine may not start if the Diesel Exhaust Fluid (AdBlue[®]) level is low. Make sure it is refilled.
-  The engine may not start if the Diesel Exhaust Fluid (AdBlue[®]) is contaminated. Replace the contaminated fluid immediately.
-  The use and refilling of Diesel Exhaust Fluid (AdBlue[®]) is mandatory for the vehicle to comply with the legal emission requirements.

Your vehicle has a selective catalytic reduction system to help reduce exhaust emission levels by injecting Diesel Exhaust Fluid (AdBlue[®]) into the exhaust system. For proper functioning of this system make sure you refill the Diesel Exhaust Fluid (AdBlue[®]) periodically.

Diesel Exhaust Fluid (AdBlue[®]) Level

For the system to operate correctly, you must maintain the Diesel Exhaust Fluid (AdBlue[®]) level.

Fuel and Refueling



A warning lamp will illuminate and a message will appear in the information display when the Diesel Exhaust Fluid (AdBlue®) level is low and needs to be refilled. Refill your vehicle with a minimum 10 L of AdBlue®.

Note: *If the warning lamp illuminates when your vehicle is moving, and the Diesel Exhaust Fluid (AdBlue®) is at a sufficient level, this indicates a system malfunction. Have your vehicle checked by an authorized dealer as soon as possible. See **Information Displays** (page 67).*

Filling the Diesel Exhaust Fluid (AdBlue®) Tank

WARNINGS



Do not allow Diesel Exhaust Fluid (AdBlue®) to come into contact with eyes, skin or clothing. Should the fluid come into contact with eyes, flush them with plenty of water and seek medical attention. Clean affected skin with soap and water. If swallowed, drink plenty of water and seek medical attention immediately.



Refill the Diesel Exhaust Fluid (AdBlue®) tank in a well-ventilated area. When removing the tank cap or a Diesel Exhaust Fluid (AdBlue®) container cap, ammonia vapor may escape. Ammonia vapor is an irritant to the eyes, skin and mucous membranes. Inhaling ammonia vapor can cause burning to the eyes, throat and nose resulting in watering eyes or severe coughing.



Do not put Diesel Exhaust Fluid (AdBlue®) in the fuel tank. This can cause engine damage not covered by the vehicle warranty.



E201520

The Diesel Exhaust Fluid (AdBlue®) tank filler neck is located next to the fuel filler neck and has a blue cap. Fill the tank using a fluid pump at a Diesel Exhaust Fluid (AdBlue®) filling station or a Diesel Exhaust Fluid (AdBlue®) container. The capacity of the Diesel Exhaust Fluid (AdBlue®) tank is 18 L.

Note: *You must open the fuel filler door before you can open the Diesel Exhaust Fluid (AdBlue®) filler door.*

Note: *Immediately wash off any Diesel Exhaust Fluid (AdBlue®) that has spilled on to a painted surface with mild soapy water.*

Filling the Diesel Exhaust Fluid (AdBlue®) Tank Using a Container

The following procedure applies to Motorcraft® Diesel Exhaust Fluid (AdBlue®) or similar diesel exhaust fluid (AdBlue®) bottles; for other brands or bottle types, refer to the instructions on the bottle label.

Fuel and Refueling

1. Remove the cap from the Diesel Exhaust Fluid (AdBlue[®]) container. Remove the spout from the bottle and insert the straw end into the bottle. Ensure you align the arrow above the nut with the bottle handle and the small tube end extends into the far corner of the bottle. Twist the spout nut on the container until it is tight.

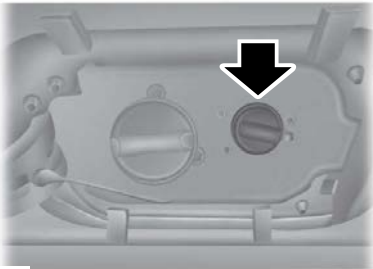

E163355

2. Open the Diesel Exhaust Fluid (AdBlue[®]) filler port on your vehicle by turning the blue end cap counterclockwise. Do not put Diesel Exhaust Fluid (AdBlue[®]) in the fuel tank. This can cause engine damage not covered by your vehicle's warranty.

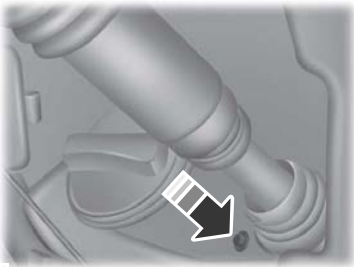

E163356

3. Lift and hold the Diesel Exhaust Fluid (AdBlue[®]) container, without tipping, and insert the spout into the Diesel Exhaust Fluid (AdBlue[®]) filler port until the small black seal on the spout completely seats into the filler port.

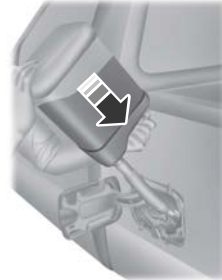

E163357

4. While filling, the fluid level in the bottle will continually drop.



E163358

5. When the Diesel Exhaust Fluid (AdBlue[®]) tank is full, the fluid level in the bottle will stop dropping, indicating the fluid has stopped flowing.

Fuel and Refueling

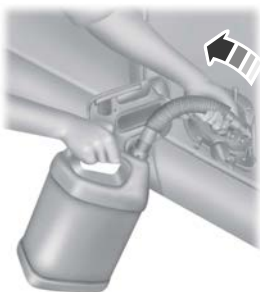

E163359

- Once the level in the Diesel Exhaust Fluid (AdBlue[®]) bottle has stopped dropping, return the container to the vertical position slightly below the Diesel Exhaust Fluid (AdBlue[®]) filler port and let any Diesel Exhaust Fluid (AdBlue[®]) drain out of the spout. DO NOT try to continue to add Diesel Exhaust Fluid (AdBlue[®]) to the tank by shaking or repositioning the container to induce flow. This may cause spilling and overflow the tank. Overfilling the Diesel Exhaust Fluid (AdBlue[®]) tank can cause damage to the tank.
- Once the spout has drained, remove the spout from the Diesel Exhaust Fluid (AdBlue[®]) filler port and install the blue cap on the Diesel Exhaust Fluid (AdBlue[®]) filler port.
- Remove the spout from the Diesel Exhaust Fluid (AdBlue[®]) container and install the cap back on the bottle.
- Wipe away any Diesel Exhaust Fluid (AdBlue[®]) that has spilled on painted surfaces with water and a damp cloth.

Note: Note: If there is Diesel Exhaust Fluid (AdBlue[®]) left in the container, retain it for later use. The spout is re-useable. Wash the spout with clean water prior to storage. Do not use the Diesel Exhaust Fluid (AdBlue[®]) spout with any other fluid.

Filling the Diesel Exhaust Fluid (AdBlue[®]) Tank Using a Fuel Station Pump

Filling the Diesel Exhaust Fluid (AdBlue[®]) tank using a pump is similar to a refuelling your vehicle. The Diesel Exhaust Fluid (AdBlue[®]) pump nozzle will shut off automatically when the tank is full.

Note: Some filling stations utilize a magnetic mechanism in the pump nozzle that may prevent refilling the Diesel Exhaust Fluid (AdBlue[®]) tank. To overcome this issue you will need to locate another filling station or use a refill container.

Filling the Diesel Exhaust Fluid (AdBlue[®]) Tank in Cold Climates

Diesel Exhaust Fluid (AdBlue[®]) may freeze if the ambient temperature is below -11°C. Your vehicle has a preheating system which allows Diesel Exhaust Fluid (AdBlue[®]) to operate below -11°C. If you do not use your vehicle for an extended period when the ambient temperature is below -11°C, the fluid in the tank may freeze. If the tank is overfilled and the fluid freezes it may damage the tank. This is not covered by the vehicle warranty.

Inoperative Selective Catalytic Reduction System, Poor Quality or Contaminated Diesel Exhaust Fluid (AdBlue[®])



If the system becomes contaminated or inoperative, the Diesel Exhaust Fluid (AdBlue[®]) warning lamp will illuminate and a message will appear in the information display. See **Information Displays** (page 67).

Note: To service a contaminated or inoperative system, see an authorized dealer.

Fuel and Refueling

Diesel Exhaust Fluid (AdBlue®) Guidelines

- Do not put Diesel Exhaust Fluid (AdBlue®) in the vehicle fuel tank.
- Do not overfill the Diesel Exhaust Fluid (AdBlue®) tank.
- Do not dilute Diesel Exhaust Fluid (AdBlue®) with water or any other liquid.
- Do not re-use a Diesel Exhaust Fluid (AdBlue®) container.
- Do not store in direct sunlight.
- Store at temperatures between -5°C and 20°C.
- Do not store a Diesel Exhaust Fluid (AdBlue®) container in your vehicle.

- Diesel Exhaust Fluid (AdBlue®) is non-flammable, non-toxic, colorless and water-soluble.
- Do not dilute Diesel Exhaust Fluid (AdBlue®) with water or any other liquid.
- An ammonia odor may be smelled when the cap is removed or during refill. Refill Diesel Exhaust Fluid (AdBlue®) in a well ventilated area.

Typical Diesel Exhaust Fluid (AdBlue®) Usage

The charts below illustrate approximate Diesel Exhaust Fluid (AdBlue®) usage for the given distances traveled under various driving conditions and when using the power take off. Your usage may vary depending on: driving style, trailer towing, loaded vehicle weight, weather, idle time, PTO usage.

5-Door			
Driving style	Trailer towing / aggressive or city driving	Normal Driving	Steady Highway Driving
Diesel Exhaust Fluid (AdBlue®) usage	3,000–12,000 km	12,000–16,000 km	16,000–18,000 km

REFUELING

WARNINGS

 Do not attempt to start the engine if you have filled the fuel tank with the incorrect fuel. This could damage the engine. Have your vehicle checked by an authorized dealer immediately.

 Do not use any kind of flames or heat near the fuel system. The fuel system is under pressure. There is a risk of injury if the fuel system is leaking.

WARNINGS

 If you use a high pressure spray to wash your vehicle, only spray the fuel filler flap briefly from a distance not less than 200 mm.

 We recommend that you wait at least 10 seconds before removing the fuel nozzle to allow any residual fuel to drain into the fuel tank.

Fuel and Refueling

WARNINGS

 Stop refueling after the fuel nozzle stops the second time. Additional fuel will fill the expansion space in the fuel tank which could lead to fuel overflowing. Fuel spillage could be hazardous to other road users.

 Do not remove the fuel nozzle from its fully inserted position during the refueling process.

Note: Central locking also locks and unlocks the fuel filler flap. See **Locking and Unlocking** (page 34).

Vehicles with Fuel Filler Cap

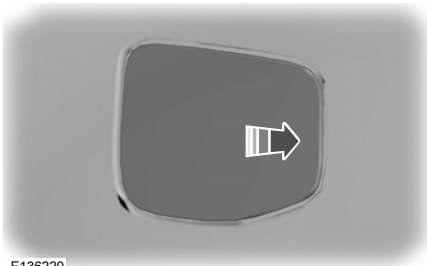

E136220

1. Press the flap to open it.

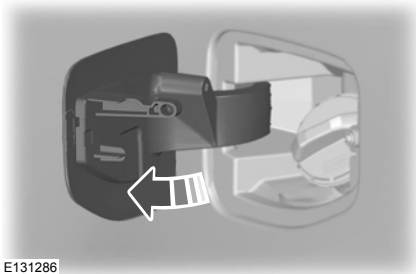

E131286

2. Open the flap fully until it engages.

3. Turn the fuel filler cap anti-clockwise.

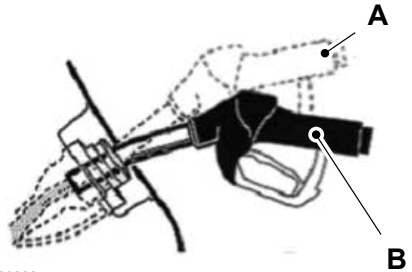

E139203

4. Hold the fuel nozzle in position B during refueling. Holding the fuel nozzle in position A can affect the flow of fuel and shut off the fuel nozzle before the fuel tank is full.

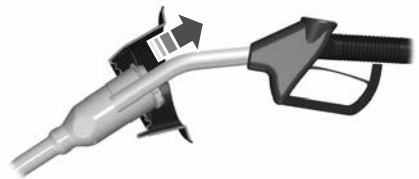

E119081

5. Slightly raise the fuel nozzle to remove it.
6. Install the fuel cap by rotating it clockwise until it clicks.
7. Close and push the fuel filler flap to lock it.

Note: If you must replace the fuel filler cap, replace only with the cap designed for your vehicle. The customer warranty may be void for any damage to the fuel tank or fuel system if the correct genuine Ford fuel filler cap is not used.

Transmission

AUTOMATIC TRANSMISSION

WARNING

 Always set the parking brake fully and make sure you move the transmission selector lever to park (P). Switch the ignition off and remove the key whenever you leave your vehicle.

Selector lever positions

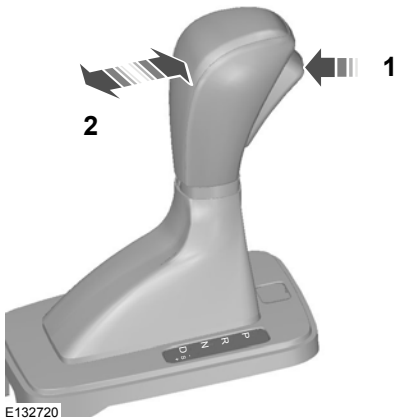

E132720

- P Park.
- R Reverse.
- N Neutral.
- D Drive.
- S Sport mode and manual shifting.
- S+ Manual shift up.
- S- Manual shift down.

WARNING

 Apply the brakes before moving the selector lever and keep them applied until you are ready to move off.

Note: A cold engine has a higher idle speed. This will increase the tendency for your vehicle to creep when you have selected a drive gear.

Press the button on the transmission selector lever to select reverse (R) and park (P).

The transmission selector lever position will be shown in the instrument cluster display.

Park (P)

WARNINGS

 Move the transmission selector lever to park (P) only when your vehicle is stationary.

 Apply the parking brake and move the transmission selector lever to park (P) before leaving your vehicle. Make sure that the transmission selector lever is latched in position.

In this position, power is not transmitted to the drive wheels and the transmission is locked. You can start the engine with the transmission selector lever in this position.

Note: To move the selector lever from park (P), apply the footbrake with ignition key in position II.

Note: An audible warning will sound if you open the driver's door and you have not moved the transmission selector lever to park (P).

Note: The battery saver will deactivate the audible warning after a period of time.

Reverse (R)

WARNINGS

 Move the transmission selector lever to reverse (R) only when your vehicle is stationary and the engine is at idle speed.

Transmission

WARNINGS



Always come to a complete stop before shifting the transmission selector lever out of reverse (R).

Move the transmission selector lever to reverse (R) to allow your vehicle to move backward.

Neutral (N)

In this position, power is not transmitted to the drive wheels but the transmission is not locked. You can start the engine with the transmission selector lever in this position.

Drive (D)

Note: A shift will occur only when your vehicle speed and the engine speed are appropriate.

Select drive (D) to shift automatically through the forward gears.

The transmission will select the appropriate gear for optimum performance based on ambient temperature, road gradient, vehicle load and your input.

Sport Mode and Manual Shifting

Sport mode

Note: In sport (S) mode the transmission operates as normal but gears are selected more quickly and at higher engine speeds.

Note: In sport mode **S** will be shown in the instrument cluster display.

Note: When towing heavy loads or in hilly terrain, it is recommended that sport (S) mode is selected. This will result in cooler transmission temperatures and additional engine braking.

Switch on sport (S) mode by moving the transmission selector lever from drive (D) towards the driver. Sport (S) mode will remain on until either you shift manually up or down the gears using **+** and **-**.

Manual shifting

WARNINGS



Do not hold the transmission selector lever permanently in **-** or **+**.



The transmission will automatically downshift when the engine speed is too low.



Manual shifting can be done only when the selector lever is in sport (S). Move the transmission selector lever forward to downshift and backward to upshift.

When the vehicle is stationary, only the 1st and 2nd gears can be selected.

Manual shifting is sequential, therefore gears cannot be skipped.

Transmission

The transmission will remain in the selected gear. When the engine speed is too low or idle, it will downshift to 2nd gear. The selected gear is indicated in the instrument cluster.

Hints on driving with an automatic transmission

WARNING



Do not idle the engine for long periods of time in drive (D) with the brakes applied.

Moving off

WARNING



It is not possible to tow-start or push-start a vehicle fitted with an automatic transmission. See **Jump Starting the Vehicle** (page 184).

1. Release the parking brake.
2. Release the brake pedal and press the accelerator pedal.

Stopping

1. Release the accelerator pedal and press the brake pedal.
2. Apply the parking brake.
3. Move the transmission selector lever to neutral (N) or park (P).

Kickdown

Press the accelerator pedal fully with the transmission selector lever in the drive (D) to select the lower gear for optimum performance. Release the accelerator pedal when you no longer require kickdown.

If Your Vehicle Gets Stuck In Mud or Snow

Note: Do not rock your vehicle if the engine is not at normal operating temperature or damage to the transmission may occur.

Note: Do not rock your vehicle for more than a minute or damage to the transmission and tires may occur, or the engine may overheat.

If your vehicle gets stuck in mud or snow, it may be rocked out by shifting between forward and reverse gears, stopping between shifts in a steady pattern. Press lightly on the accelerator in each gear.

Emergency Park Position Release Lever

WARNINGS



Do not drive your vehicle until you verify that the brake lamps are working.



If the parking brake is fully released, but the brake warning lamp remains illuminated, the brakes may not be working correctly. See an authorized dealer.

Use the button to move the transmission selector lever from the park (P) in the event of an electrical malfunction or if your vehicle battery has no charge.

Transmission



1. Apply the parking brake and switch the ignition off before performing this procedure.
2. Lift up the cover in the center console next to the transmission selector lever with a suitable tool.
3. Push down the locking button in the slot and simultaneously move the selector lever out of park (P).

Note: Take care when opening the cover.

Note: See an authorized dealer as soon as possible if this procedure is used.

ELECTRONIC LOCKING DIFFERENTIAL

Note: The electronic locking differential is for off-road use only and is not for use on dry pavement. Using the electronic locking differential on dry pavement will result in increased tire wear, noise, vibration and damage to the axle.

The electronic locking differential is a device housed in the rear axle that allows both rear wheels to turn at the same speed. The electronic locking differential can provide additional traction should your vehicle become stuck. You can activate

the differential electronically and shift it on the fly within the differential operating speed range. The differential is for use in mud, rocks, sand, or any off-road condition where you need maximum traction. It is not for use on dry pavement.

The following conditions will affect the electronic locking differential:

- The electronic locking differential will not engage if your vehicle speed is too high (above 35 km/h in Normal mode).
- The electronic locking differential will automatically disengage when speed is too high and will automatically re-engage when vehicle speed is low enough.
- The Electronic Locking Differential may not engage if you are cornering and/or if one rear wheel is spinning. A message may appear in the instrument display informing you to release the accelerator.
- The speeds for engagement / disengagement are different in different terrain modes.
- The ESC (electronic stability control) system has the ability to disable the electronic locking differential during driving maneuvers when necessary.

When you switch the system on, if you do not meet the required conditions for electronic locking differential activation, the instrument cluster will display the appropriate information guiding you through the proper activation process.

Activating the Electronic Locking Differential

Note: Do not use electronic locking differential on dry, hard surfaced roads. Doing so will produce excessive noise, vibration, increase tire wear and damage to the axle.

Transmission

Note: *If the electronic locking differential has difficulty disengaging, release the accelerator pedal and turn the steering wheel while rolling.*



E206626

To engage the electronic locking differential, press the centre console mounted switch.

All-Wheel Drive

USING ALL-WHEEL DRIVE

The all-wheel drive system in your vehicle is an intelligent system that continuously monitors vehicle conditions and automatically adjusts the power distribution between the front and rear wheels. It combines transparent all-surface operation with highly capable all-wheel drive. The all-wheel drive system is always active and requires no driver input, however the driver can optimize more control by utilising the terrain management switch and low range selection switch, mounted in the centre console, for the correct terrain conditions.

WARNING



Vehicles with a higher centre of gravity such as all-wheel drive vehicles handle differently than vehicles with a lower centre of gravity. All-wheel drive vehicles are not designed for cornering at speeds as high as passenger cars any more than low-slung sports cars are designed to perform satisfactorily under off-road conditions. Avoid sharp turns, excessive speed and abrupt manoeuvres in these vehicles. Failure to drive cautiously could result in an increased risk of loss of vehicle control, vehicle rollover, personal injury and death.

The intelligent AWD system continuously monitors vehicle conditions and automatically adjusts the power distribution between the front and rear wheels. It combines transparent all-surface operation with highly capable all-wheel drive.

The AWD system is always active and requires no driver input. It is capable of handling all road conditions, including street and highway driving as well as off-road and winter driving. The driver can optimize more AWD control by moving the terrain management switch for the correct terrain. See **Off-Road Driving** (page 177).

Brakes

GENERAL INFORMATION

WARNING



The system does not relieve you of your responsibility to drive with due care and attention.

Note: Occasional brake noise is normal. If a metal-to-metal, continuous grinding or continuous squeal sound is present, the brake linings may be worn-out. If the vehicle has continuous vibration or shudder in the steering wheel while braking, have your vehicle checked by an authorized dealer.

Note: Brake dust may accumulate on the wheels, even under normal driving conditions. Some dust is inevitable as the brakes wear.

Wet brakes result in reduced braking efficiency. Gently press the brake pedal a few times when driving from a car wash or standing water to dry the brakes.

Anti-lock Brake System

This system helps you maintain steering control and vehicle stability during emergency stops by keeping the brakes from locking.

HINTS ON DRIVING WITH ANTI-LOCK BRAKES

Note: When the system is operating, the brake pedal may pulse and may travel further. Maintain pressure on the brake pedal. You may also hear a noise from the system. This is normal.

The anti-lock braking system will not eliminate the risks when:

- You drive too closely to the vehicle in front of you.
- Your vehicle is hydroplaning.

- You take corners too fast.
- The road surface is poor.

PARKING BRAKE

WARNING



Always set the parking brake fully and make sure you shift the gearshift lever to park (P). Switch the ignition off and remove the key whenever you leave your vehicle.

Note: Do not press the release button while pulling the lever up.

To apply the parking brake:

1. Press the foot brake pedal firmly.
2. Pull the parking brake lever up to its fullest extent.

Note: If you park your vehicle on a hill and facing uphill, shift the gearshift lever to park (P) and turn the steering wheel away from the curb.

Note: If you park your vehicle on a hill and facing downhill, shift the gearshift lever to park (P) and turn the steering wheel toward the curb.

To release the parking brake:

1. Press the brake pedal firmly.
2. Pull the lever up slightly.
3. Press the release button and push the lever down.

HILL START ASSIST

WARNINGS



The system does not replace the parking brake. When you leave your vehicle, always apply the parking brake and move the transmission selector lever into position park (P).

Brakes

WARNINGS



You must remain in your vehicle once you have turned the system on.



The system is active unless ESC warning lamp is turned off. During all times, you are responsible for controlling your vehicle, supervising the system and intervening, if required.



If the engine is revved excessively or if a malfunction is detected, the system will turn off and ESC warning lamp will turn on.



There is a short delay in the system activation of up to two seconds after the shifting the lever to drive (D) or reverse (R) in vehicles with automatic transmission.

The system makes it easier to pull away when your vehicle is on a slope without the need to use the parking brake.

When the system is active, your vehicle will remain stationary on the slope for two to three seconds after you release the brake pedal. This allows you time to move your foot from the brake to the accelerator pedal. The brakes are released automatically once the engine has developed sufficient drive to prevent your vehicle from rolling down the slope. This is an advantage when pulling away on a slope, (for example from a car park ramp, traffic lights or when reversing uphill into a parking space).

The system will turn on automatically on any slope which can result in significant vehicle rollback.

Note: *Hill start assist is available in vehicles equipped with electronic stability control (ESC).*

Using Hill Start Assist

1. Press the brake pedal to bring your vehicle to a complete standstill. Keep the brake pedal pressed.
2. If the sensors detect that your vehicle is on a slope, the system will be activated automatically.
3. When you remove your foot from the brake pedal, your vehicle will remain on the slope without rolling away for approximately two or three seconds. This hold time will automatically be extended if you are in the process of driving off.
4. Drive off in the normal manner. The brakes will be released automatically.

Enable and Disable the System

You can enable the system only if the following conditions are met:

- The engine is running.
- All doors are fully closed.
- The parking brake is fully disengaged.
- No failure mode is present.
- Accelerator pedal is not depressed.
- Vehicle is completely stopped.
- Uphill: Gear shift lever should be in position drive (D) for Automatic transmission and in any position other than reverse for manual transmission.
- Downhill: Gear shift lever should be in reverse (R).

To disable the system, perform one of the following:

- Apply the parking brake.
- Open any door.
- Drive off uphill without re-applying the brake.
- Wait for one to two seconds after you remove your foot from the brake pedal.

Brakes

- If the system is active in a forward gear, select reverse gear.
- If the system is active in neutral, release the clutch pedal (Manual transmission).
- If the system is active in reverse gear, select neutral.

Switching the System On and Off

Note: *You can only switch the system on and off if your vehicle has a manual transmission.*

Note: *The system will remain on or off depending on how it was last set.*

Your vehicle comes with this feature already enabled. If required, you can switch this feature off using the information display. See **General Information** (page 67).

Traction Control

PRINCIPLE OF OPERATION

The traction control system helps avoid drive wheel spin and loss of traction.

If your vehicle begins to slide, the system applies the brakes to individual wheels and, when needed, reduces engine power at the same time. If the wheels spin when accelerating on slippery or loose surfaces, the system reduces engine power in order to increase traction.

USING TRACTION CONTROL

Traction control forms part of the stability control system.

Note: *The system automatically turns on every time you switch the ignition on.*

Note: *Switching off the stability control will turn off the system.*

In certain situations (e.g. stuck in snow or mud), turning the system off may be beneficial as this allows the wheels to spin with full engine power.

Traction control is an enhanced feature of stability control system and automatically detects the wheel spin when you accelerate. If this situation occurs, the system applies your vehicle brakes at individual wheels and if necessary, reduces engine power.

Note: *Shifting to 4x4 Low deactivates engine traction control but brake traction control remains active.*

To switch off the traction control, See **Using Stability Control** (page 135).

Stability Control

PRINCIPLE OF OPERATION

WARNINGS



Vehicle modifications involving braking system, aftermarket roof racks, suspension, steering system, tire construction and wheel and tire size may change the handling characteristics of your vehicle and may adversely affect the performance of the electronic stability control system. In addition, installing any stereo loudspeakers may interfere with and adversely affect the electronic stability control system. Install any aftermarket stereo loudspeaker as far as possible from the front center console, the tunnel, and the front seats in order to minimize the risk of interfering with the electronic stability control sensors. Reducing the effectiveness of the electronic stability control system could lead to an increased risk of loss of vehicle control, vehicle rollover, personal injury and death.



Remember that even advanced technology cannot defy the laws of physics. It's always possible to lose control of a vehicle due to inappropriate driver input for the conditions. Aggressive driving on any road condition can cause you to lose control of your vehicle increasing the risk of personal injury or property damage. Activation of the electronic stability control system is an indication that at least some of the tires have exceeded their ability to grip the road; this could reduce the operator's ability to control the vehicle potentially resulting in a loss of vehicle control, vehicle rollover, personal injury and death. If your electronic stability control system activates, SLOW DOWN.

The system automatically turns on each time you switch the ignition on.

If a driving condition activates either the stability control or the traction control system you may experience the following conditions:

- The stability and traction control light flashes.
- Your vehicle slows down.
- Reduced engine power.
- A vibration in the brake pedal.
- The brake pedal is stiffer than usual.
- If the driving condition is severe and your foot is not on the brake, the brake pedal may move as the systems applies higher brake forces.

The stability control system has several features built into it to help you maintain control of your vehicle:

Electronic Stability Control

The system enhances your vehicle's ability to prevent skids or lateral slides by applying brakes to one or more of the wheels individually and, if necessary, reducing engine power.

Roll Stability Control

The system enhances your vehicle's ability to prevent rollovers by detecting your vehicle's roll motion and the rate at which it changes by applying the brakes to one or more wheels individually.

Curve Control

The system enhances your vehicle's ability to follow the road when cornering severely or avoiding objects in the roadway. Curve Control operates by reducing engine power and, if necessary, applying brakes to one or more of the wheels individually.

Stability Control

Traction Control

The system enhances your vehicle's ability to maintain traction of the wheels by detecting and controlling wheel spin. See **Principle of Operation** (page 134).

Principle of Operation (page 134).



E207884

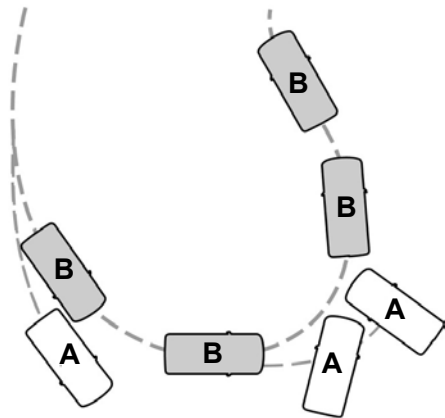

E72903

- A Vehicle without stability control skidding off its intended route.
- B Vehicle with stability control maintaining control on a slippery surface.

USING STABILITY CONTROL

Note: *The system is automatically activated when you start the engine.*

To switch off the stability control, press the stability control button on the floor console.

Hill Descent Control

PRINCIPLE OF OPERATION

WARNING



Before driving off-road it is absolutely essential that in-experienced drivers become fully familiar with the vehicle's controls. In particular, Sport mode and Hill Descent Control (HDC).

Hill descent control (HDC) operates in conjunction with stability control (ESC) to provide greater control when off-road, particularly when descending steep slopes. HDC operation is fully automatic when engaged.

Engine braking controls the speed of the descent during an off-road hill descent. If engine braking alone is insufficient to control the vehicle's speed, HDC will slow the vehicle using the braking system.

Note: Use HDC only in first or reverse gear in manual transmission vehicles.

Note: Use HDC only in drive (D), reverse (R) or sport (S) mode in automatic transmission vehicles. When in drive (D), the vehicle will select the most appropriate gear.

USING HILL DESCENT CONTROL

Selecting HDC

Select HDC at speeds less than 60 km/h. To select HDC, press the hill descent control switch located on the floor console.



E216471

Note: HDC will be active at speeds less than 35 km/h and deactivated above 40 km/h but will not turn off until vehicle exceeds 60 km/h.

Note: HDC will turn off when you switch the ignition off.



The HDC switch will illuminate continuously to indicate that HDC is fully active.

HDC will temporarily deactivate during the following conditions:

- The brakes are hot. Operation resumes once the brakes cool down.
- The stability control indicator on warning lamp is illuminated and operating.

Hill Descent Control

HDC Operation

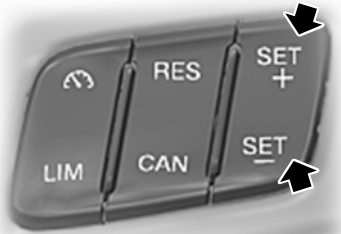

E206132

Cruise control switches on the steering wheel allow you to control your hill descent speed. **SET +** increases the speed and **SET -** decreases the speed.

Changing the Set Speed

- Press and hold **SET+** or **SET-**. Release the control when you reach the desired speed.
- Press and release **SET+** or **SET-**. The set speed will change in approximately 1 km/h increments.

Pressing the accelerator pedal or brake pedal will increase or decrease the speed respectively.

Note: Each gear has a pre-determined minimum speed.

Note: Descent speed will only increase on a slope steep enough to provide additional momentum. Therefore, use of the **SET+** switch on a gentle slope may not increase the speed.

Note: The Brakes will override the HDC if the brake pedal is pressed. The system resumes on the release of the brake pedal.

Note: HDC assistance will fade out gradually if you switch the system off. This is to prevent the loss of control if you press the HDC switch unintentionally. If assistance is still required, you can switch back the HDC on. The control will resume at a speed the vehicle is travelling when the pedal is released.

Note: You may hear a noise from the system. This is normal.

Note: When HDC is operating, the ESC on warning lamp will flash.

HDC operates only if the vehicle speed is within the specified range even if the system is on permanently during off-road driving.

Parking Aids

PRINCIPLE OF OPERATION

WARNINGS



The system does not relieve you of your responsibility to drive with due care and attention.



If your vehicle has a non-Ford approved trailer tow module the system may not correctly detect objects.



The sensors may not detect objects in heavy rain or other conditions that cause disruptive reflections.



The sensors may not detect objects with surfaces that absorb ultrasonic waves.



The system does not detect objects that are moving away from your vehicle. They will only be detected shortly after they start to move toward your vehicle.



Take particular care when reversing with a tow ball arm or a rear fitted accessory. For example, a bicycle carrier. The rear parking aid will only indicate the approximate distance from the rear bumper to an object.



Sensing is only an aid to detect some objects when moving forward or backward at low speeds. Traffic control systems, inclement weather or an external motor and fan can affect the sensors; this may include reduced performance or false activation. To help avoid personal injury you must read and understand the limitations of the system detailed in this section.

WARNINGS



The parking aid system may not prevent contact with small or moving objects that are close to the ground. The parking aid system gives an audible warning when it detects a large object helping to avoid damage to your vehicle. To help avoid personal injury you must take care when using the parking aid system.

Note: *If you use a high pressure spray to wash your vehicle, only spray the sensors briefly from a distance not less than 20 cm.*

Note: *If your vehicle has a tow ball arm, the system is turned off automatically when trailer lamps (or lighting boards) are connected to the 13-pin socket through a Ford approved trailer tow module.*

Note: *Keep the sensors free from dirt, ice or snow. Do not clean with sharp objects.*

Note: *The system may emit false alerts if it detects a signal using the same frequency as the sensors or if your vehicle is fully loaded.*

Note: *The outer sensors may detect the side walls of a garage. If the distance between the outer sensors and the side wall remains constant for three seconds, the alert will turn off. As you continue the inner sensors will detect objects directly behind your vehicle.*

REAR PARKING AID

The rear sensors are only active when the transmission is in reverse (R). As your vehicle moves closer to the obstacle, the rate of the audible warning increases. When the obstacle is less than 30 cm away, the warning sounds continuously. If

Parking Aids

the system detects a stationary or receding object farther than 30 cm from the corners of the bumper, the tone sounds for only three seconds. Once the system detects an object approaching, the warning sounds again.



E130178

Coverage area of up to 1.8 m from the rear bumper. There may be decreased coverage area at the outer corners of the bumper.

The system provides audio warnings only when your vehicle is moving or when your vehicle is stationary and the detected obstacle is less than 30 cm away from the bumper.

Obstacle Distance Indicator

The system provides obstacle distance indication through the information display.

The indicator displays:

- As the distance to the obstacle changes the indicator blocks illuminate the position of obstacle relative to the vehicle icon.
- If there is no obstacle detected, the distance indicator blocks are greyed out.

FRONT PARKING AID

The front sensors are active when the transmission is in any position other than park (P) and the vehicle is not in a standstill position.



E187330

Coverage area is up to 70 cm from the front bumper. There is decreased coverage area at the outer corners.

When your vehicle approaches an object, a warning tone sounds. When your vehicle moves closer to an object, the warning tone repeat rate increases. The warning tone sounds continuously when an object is 30 cm or less from the front bumper.

Obstacle Distance Indicator

The system provides obstacle distance indication through the information display.

The indicator displays:

- As the distance to the obstacle decreases the indicator blocks illuminate and move towards the vehicle icon.
- If there is no obstacle detected, the distance indicator blocks are greyed out.

Parking Aids

If the transmission is in reverse (R), the front sensing system provides audible warnings when your vehicle is moving and the detected obstacle is moving towards your vehicle. Once the vehicle is stationary, the audible warning will be stopped after 2 seconds.

If the transmission is in drive (D) or any other forward gear (for example, sport (S), manual transmissions), the front sensing system provides audible and visual warnings when your vehicle is moving below a speed of 12 km/h and an obstacle is located inside the detection area. Once the vehicle is stationary, the audible warning will be stopped after 2 seconds and the visual indication stops after 4 seconds. If the obstacles detected are within 30 cm, the visual indication remains on.

Vehicles with automatic transmission

If the transmission is in neutral (N), the system provides visual indication only when your vehicle is moving at 12 km/h or below and an obstacle is located inside the detection area. Once your vehicle is stationary, the visual indication will stop after 4 seconds.

ACTIVE PARK ASSIST

Parallel Parking

WARNINGS



You must remain in your vehicle when the system turns on. At all times, you are responsible for controlling your vehicle, supervising the system and intervening, if required. Failure to take care may result in the loss of control of your vehicle, serious personal injury or death.



The sensors may not detect objects in heavy rain or other conditions that cause interference.

Note: *The driver is always responsible for controlling the vehicle, supervising the system and intervening, if required by grabbing the steering wheel or pushing the active park assist button.*

The system detects an available parallel parking space and automatically steers your vehicle into the space (hands-free) while you control the accelerator, gearshift and brakes. The system visually and audibly guides you to park your vehicle.

If you are uncomfortable with the proximity to any vehicle or object, you may choose to override the system.

Note: *The blindspot information system does not detect traffic alongside or behind your vehicle during a park assist maneuver.*

The system may not correctly operate in any of the following conditions:

- You use a spare tire or a tire significantly worn more than the other tires.
- You use an unauthorized tire size.
- You try to park on a tight curve.
- Something passes between the front bumper and the parking space (a pedestrian or cyclist).
- The edge of the neighboring parked vehicle is high off the ground (for example, a bus, tow truck or flatbed truck).
- The weather conditions are poor (heavy rain, snow, fog, etc).

Note: *Keep the sensors, located on the bumper or fascia, free from snow, ice and large accumulations of dirt. Covered sensors can affect the system's accuracy. Do not clean the sensors with sharp objects.*

Note: *The sensors may not detect objects with surfaces that absorb ultrasonic waves or cause ultrasonic interference (motorcycle exhaust, truck air brakes or horns).*

Parking Aids

Do not use the system if:

- You have attached a foreign object (bike rack or trailer) to the front or rear of your vehicle or close to the sensors.
- You have attached an overhanging object (surfboard) to the roof.
- A foreign object damages or obstructs the front or rear bumper or side sensors.
- The correct tire size is not in use on your vehicle (for example, a mini-spare tire).

Using Active Park Assist - Parallel Parking



Press the button located on the center console near the gearshift lever or the right side of the center stack once.

When driving at a speed less than 35 km/h the system automatically scans both sides of your vehicle for an available parking space. The system displays a message and a corresponding graphic to indicate it is searching for a parking space. Use the direction indicator to display the searching results either the left-hand side or right-hand side of your vehicle.

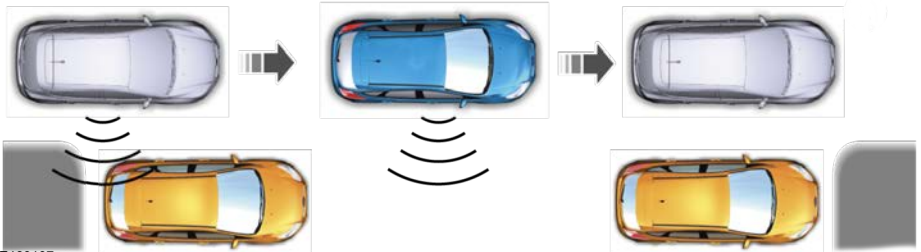

E130107

Note: If the direction indicators are not used, the system defaults to the passenger side of your vehicle.

Note: The system passively searches for parking spaces prior to pressing the button, so activating the system is still possible while passing a parking space.

When the system finds a suitable space, it displays a message and a tone sounds. Stop your vehicle and follow the instructions on the screen. If your vehicle is moving very slowly, you may need to pull forward a short distance before the system is ready to park.

If the vehicle has been travelling over a certain distance, the found space may be discarded and the system will go back to searching for a suitable space.

Note: You must observe that the selected space remains clear of obstructions at all times during the maneuver.

Note: Active park assist may not detect street furniture and other items. You must make sure the selected space is suitable for parking.

Note: You should drive your vehicle within 1.5 m to the other vehicles while passing a parking space.

Parking Aids

Note: The system always offers the last detected parking space (for example, if your vehicle detects multiple spaces while you are driving, it offers the last one).

Note: If driven above approximately 35 km/h, the system shows a message to alert you to reduce your vehicle speed.

Automatic Steering into Parking Space

Note: If your vehicle speed exceeds 9 km/h or the maneuver is interrupted (driver input), the system switches off and you need to take full control of your vehicle.

When you shift the transmission into reverse (R), with your hands off the wheel (and nothing obstructing its movement), your vehicle steers itself into the space. The system displays instructions to move your vehicle back and forth in the space.

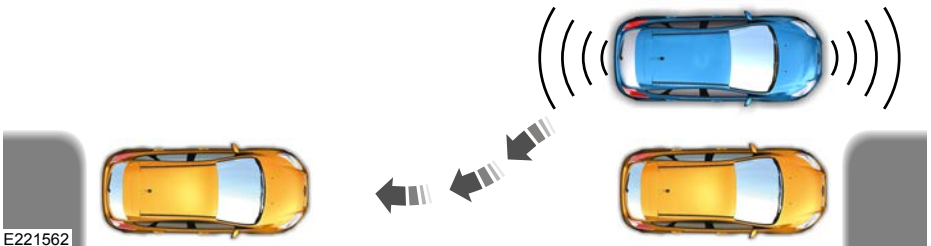

When you think your vehicle is properly parked, or you hear a solid tone from the parking aid (accompanied by a display message and a chime), bring your vehicle to a complete stop.

When automatic steering is complete, the system displays a message and a tone sounds, indicating that the active park assist process is finished. You are responsible for checking the parking job and making any necessary corrections before leaving your vehicle.

Deactivating the Active Park Assist Feature

Manually deactivate the system by:

- Pressing the active park assist button when the system is enabled.
- Grabbing the steering wheel during an active maneuver.

- Driving above approximately 35 km/h for 30 seconds during an active park search.
- Driving above 9 km/h during automatic steering.
- Switching off the traction control system.

Certain vehicle conditions can also deactivate the system, such as:

- Traction control has activated.
- There is an anti-lock brake system activation or failure.

If a problem occurs with the system, a warning message displays accompanied by a tone. Occasional system messages may occur in normal operation. For recurring or frequent system faults, contact an authorized dealer to have your vehicle serviced.

Parking Aids

Troubleshooting the System

The system does not look for a space

The traction control system is off.

The transmission is in reverse (R). Your vehicle must be moving forward to be able to detect a parking space.

The system does not offer a particular space

The sensors may be covered (for example, snow, ice or dirt buildup). Covered sensors can affect the system's functionality.

There is not enough room in the parking space for your vehicle to safely park.

There is not enough space for the parking maneuver on the opposite side of the parking space.

The parking space is farther than 1.5 m or closer than 0.4 m away.

The transmission is in reverse (R). Your vehicle must be moving forward to be able to detect a parking space.

Your vehicle is going faster than 35 km/h for parallel parking.

The system does not position the vehicle where I want in the space

Your vehicle is rolling in the opposite direction of the transmission (rolling forward with reverse [R] selected).

An irregular curb along the parking space prevents the system from aligning your vehicle properly.

Vehicles or objects bordering the space may not be positioned correctly.

You pulled your vehicle too far past the parking space. The system performs best when you drive the same distance past the parking space.

The tires may not be installed or maintained correctly (not inflated correctly, improper size, or of different sizes).

A repair or alteration has changed detection capabilities.

Parking Aids

The system does not position the vehicle where I want in the space

- A parked vehicle has a high attachment (salt sprayer, snowplow or moving truck bed).
- The parking space length or position of parked objects changed after your vehicle passed.
- The temperature around your vehicle changes quickly (driving from a heated garage into the cold, or after leaving a car wash).

REAR VIEW CAMERA (If Equipped)

WARNINGS



The operation of the camera may vary depending on the ambient temperature, vehicle and road conditions.



The distances shown in the display may differ from the actual distance.



Do not place objects in front of the camera.

The camera is on the liftgate near the license plate.



E142435

Turning the Rear View Camera On

WARNING



The camera may not detect objects that are very close to your vehicle.

Switch the ignition and the audio unit on.

Move the transmission selector lever to reverse (R).

The image displays in the center of the instrument panel.

The system may not correctly operate in any of the following conditions:

- Dark areas.
- Intense light.
- If the ambient temperature increases or decreases rapidly.
- If the camera is wet, for example in rain or high humidity.
- If the camera's view is obstructed, for example by mud.

Using the Display

WARNINGS



Objects above the camera may not be visible. Check the area behind your vehicle when necessary.



Marks are for general guidance only, and are calculated for vehicles in maximum load conditions on an even road surface.

The lines show the distance from the outer edge of the front tire plus 50 millimetres (2 inches) and the rear bumper.

Parking Aids

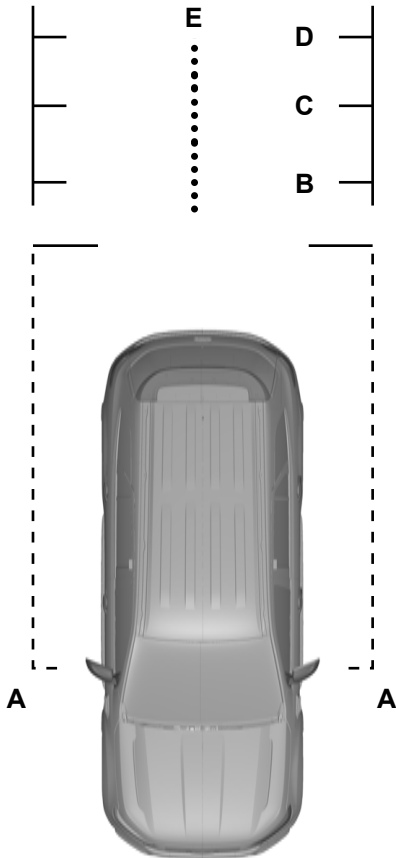

- D Green - 1.8 metres (71 inches).
- E Black - center line of the projected vehicle path.

Note: When reversing with a trailer the camera shows the direction of your vehicle and not the direction of the trailer.

Turning the Rear View Camera Off

Move the transmission selector lever from reverse (R).

Note: The system will automatically switch off once your vehicle speed has reached approximately 15 km/h if you have switched on the camera delay in the information display.

E200774

- A Exterior mirror clearance - 0.05 metres (2 inches).
- B Red - up to 0.45 metres (17 inches).
- C Amber - 1.0 metres (40 inches).

Cruise Control

PRINCIPLE OF OPERATION

WARNING



The system does not relieve you of your responsibility to drive with due care and attention.

Cruise control allows you to control your speed using the switches on the steering wheel. You can use cruise control when you exceed approximately 30 km/h.

USING CRUISE CONTROL

WARNINGS



Do not use cruise control in heavy traffic, on winding roads or when the road surface is slippery. This could result in loss of vehicle control, serious injury or death.



When you are going downhill, your vehicle speed may increase above the set speed. The system will not apply the brakes. Change down a gear to assist the system in maintaining the set speed. Failure to do so could result in loss of vehicle control, serious injury or death.

Note: *Cruise control will disengage if your vehicle speed decreases more than 16 km/h below your set speed while driving uphill.*

The cruise control switches are located on the steering wheel.

Switching Cruise Control On



E201284

Press the button.

Setting a Speed

- Accelerate to the desired speed.
- Press and release **SET+**.



The warning indicator will display in the instrument cluster.

- Take your foot off the accelerator pedal.

Changing the Set Speed

- Press and hold **SET+** or **SET-**. Release the control when you reach the desired speed.
- Press and release **SET+** or **SET-**. The set speed will change in approximately 1 km/h (1 mph) increments.
- Press the accelerator or brake pedal until you reach the desired speed. Press and release **SET+**.

Canceling the Set Speed

Press and release **CAN** or tap the brake pedal. The system will not erase the set speed.

Resuming the Set Speed

Press and release **RES**.

Cruise Control

Switching Cruise Control Off

Note: You will erase the set speed if you switch the system off.

Press and release **OFF** or switch the ignition off.

USING ADAPTIVE CRUISE CONTROL (If Equipped)

WARNINGS



Always pay close attention to changing road conditions when using adaptive cruise control. The system does not replace attentive driving. Failing to pay attention to the road may result in a crash, serious injury or death.



Adaptive cruise control is not a crash warning or avoidance system.



Adaptive cruise control does not detect stationary or slow moving vehicles.



Adaptive cruise control does not detect pedestrians or objects in the road.



Adaptive cruise control does not detect oncoming vehicles in the same lane.



Do not use adaptive cruise control on winding roads, in heavy traffic or when the road surface is slippery.

This could result in loss of vehicle control, serious injury or death.



Do not use the system in poor visibility, for example fog, heavy rain, spray or snow.

WARNINGS



Do not use the system when towing a trailer with brake controls.

Aftermarket trailer brakes will not operate when you switch the system on because the brakes are electronically controlled. Failure to do so may result in loss of vehicle control, which could result in serious injury.



Do not use tire sizes other than those recommended because this can affect the normal operation of the system. Failing to do so may result in a loss of vehicle control, which could result in serious injury.

Note: It is your responsibility to stay alert, drive safely and be in control of the vehicle at all times.

The system is designed to help you maintain a gap from the vehicle in front of you. If there is no vehicle in front of you the system will maintain a set speed. The system is intended to provide enhanced operation of your vehicle when following other vehicles which are in the same lane and traveling in the same direction. You can select from one of four gap settings.

The system is based on the use of a radar sensor which projects a beam directly forward of your vehicle.

Cruise Control

Adaptive Cruise Controls

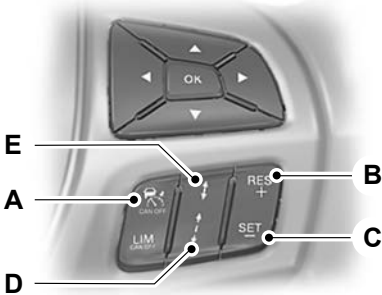

E206151

- A On, off and cancel.
- B Set speed increase and resume.
- C Set speed and speed decrease.
- D Gap increase.
- E Gap decrease.

Switching the System On

Press and release the Adaptive Cruise Control **CNCL/OFF** button.

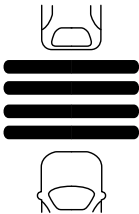

E164805

The cruise control indicator, **SET kph (mph)**, the current gap setting indicator and **Standby** displays in the instrument cluster.

Setting the Adaptive Cruise Speed

1. Drive to desired speed.
2. Press and release **SET-** or **RES+**.
3. The information display shows a green indicator light, current gap setting and desired set speed.
4. Take your foot off the accelerator pedal.

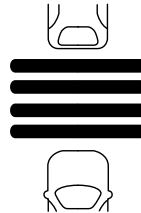

E164805

5. When the system detects a vehicle in front of you, it will be displayed above the horizontal bars.

Note: When adaptive cruise control is active, the set speed displayed in the information display may vary slightly from the speedometer.

Changing the Set Speed

- Press and release **SET-** or **RES+**. The set speed changes in 5 km/h or 2 km/h increments depending on your vehicle.
- Press the accelerator or brake pedal until you reach the desired speed. Press and release **SET-** or **RES+**.
- Press and hold **SET-** or **RES+**. Release the control when you reach the desired speed.

The system may apply the brakes to slow the vehicle to the new set speed. The set speed displays continuously in the information display when the system is active.

Cruise Control

Canceling the Set Speed

Press the brake pedal or the clutch pedal for an extended period, or press and release the Adaptive Cruise Control **CNCL/OFF** button. The last set speed displays with a strikethrough.

Resuming the Set Speed

Press and release **RES+**. The vehicle returns to the previously set speed and gap setting. The set speed displays continuously in the information display while the system is active.

Switching the System Off

Press and release the Adaptive Cruise Control **CNCL/OFF** button when the system is in stand by mode or switch the ignition off.

Note: *You erase the set speed when you switch the system off.*

Following a Vehicle

WARNINGS



When following a vehicle, your vehicle does not decelerate automatically to a stop, nor does your vehicle always decelerate quickly enough to avoid a crash without driver intervention. Always apply the brakes when necessary. Failing to do so may result in a crash, serious injury or death.



Adaptive cruise control only warns of vehicles detected by the radar sensor. In some cases there may be no warning or a delayed warning. You should always apply the brakes when necessary. Failing to do so may result in a crash, serious injury or death.

When a vehicle ahead of you enters the same lane or a slower vehicle is ahead in the same lane, the vehicle speed adjusts to maintain a preset gap.

The lead vehicle graphic illuminates.

Your vehicle maintains a constant gap behind the vehicle ahead until:

- The vehicle in front of you accelerates to a speed above the set speed.
- The vehicle in front of you moves out of your lane or out of view.
- The vehicle speed falls below 20 km/h.
- A new gap is set.

The system applies the brakes to slow your vehicle to maintain a safe gap from the vehicle in front. The maximum braking which the system can apply is limited. You can override the system by applying the brakes.

If the system predicts that its maximum braking level is insufficient, an audible warning sounds while the system continues to brake. The red warning bar appears on the windshield. You should take immediate action.

Note: *The brakes may emit a sound when modulated by the adaptive cruise control system.*

Setting the Gap

Note: *It is your responsibility to select a gap appropriate to the driving conditions.*

You can decrease or increase the gap between your vehicle and the vehicle in front of you by pressing the gap control.

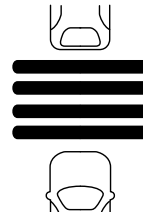

E164805

Cruise Control

The selected gap appears in the information display as shown by the bars in the graphic. You can select from one of four gap settings.

Note: *The gap setting is time dependent and therefore the distance will automatically adjust with your speed.*

Adaptive cruise control gap settings

Set speed km/h	Graphic display, bars indicated between vehicles	Time gap, seconds	Gap m
100	1	0.8	28
100	2	1.2	39
100	3	1.6	50
100	4	2.1	61

Note: *The system status and settings will remain unchanged each time you switch the ignition on.*

Overriding the System

WARNING



Whenever the driver is overriding the system by pressing the accelerator pedal, the system does not automatically apply the brakes to maintain separation from any vehicle ahead.

You can override the set speed and gap by pressing the accelerator pedal.



When you override the system, the green indicator light illuminates and the set speed text darkens.

The system resumes operation when you release the accelerator pedal. The vehicle speed decreases to the set speed, or a lower speed if following a slower vehicle.

Automatic Cancellation

The system does not operate below 20 km/h. An audible warning sounds and the automatic braking releases if the vehicle drops below this speed.

Automatic cancellation can also occur if:

- The tires lose traction.
- The engine speed is too low.
- You apply the parking brake.

Note: *If the engine speed drops too low, the information display indicates low engine speed. Shift to a lower gear (manual transmission only) to avoid automatic cancellation.*

Hilly Condition Usage

You should select a lower gear position when the system is active in situations such as prolonged downhill driving on steep grades, for example in mountainous areas. The system needs additional engine braking in these situations to reduce the load on the vehicle's regular brake system to prevent them from overheating.

Note: *An audible warning sounds and the system shuts down if it applies brakes for an extended period of time. This allows the brakes to cool down. The system functions normally again when the brakes have cooled down.*

Cruise Control

Detection Issues

WARNING



On rare occasions, detection issues can occur due to the road infrastructures, for example bridges, tunnels and safety barriers. In these cases, the system may brake late or unexpectedly. At all times, you are responsible for controlling your vehicle, supervising the system and intervening, if required.

The radar sensor has a limited field of vision. It may not detect vehicles at all or detect a vehicle later than expected in some situations. The lead vehicle graphic does not illuminate if the system does not detect a vehicle in front of you.

A

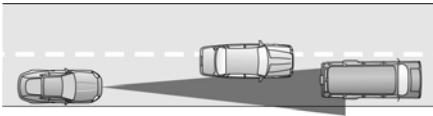

B

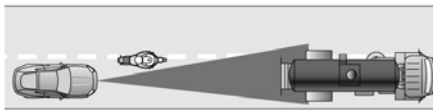

C

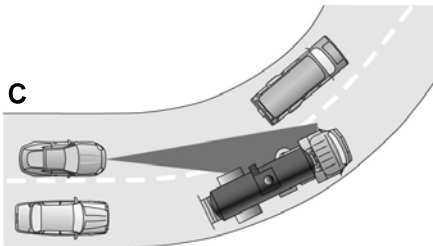

E71621

Detection issues can occur:

- A With vehicles that edge into your lane that can only be detected once they have moved fully into your lane.
- B Motorcyclists may be detected late, or not at all.
- C With vehicles in front of you when going into and coming out of a bend. The detection beam will not follow sharp curves in the road.

In these cases the system may brake late or unexpectedly. You should stay alert and intervene if necessary.

If something hits the front of your vehicle or damage occurs, the radar-sensing zone may change. This could cause missed or false vehicle detections. Contact your authorized dealer as soon as possible.

System Not Available

Conditions that can cause the system to deactivate or prevent the system from activating when requested include:

- A blocked sensor.
- High brake temperature.
- A failure in the system or a related system.

Blocked Sensor

A message displays if something obstructs the radar signals from the sensor. The sensor is located on the lower grille. The system cannot detect a vehicle ahead and does not function when something obstructs the radar signals.

Keep the front of your vehicle free of dirt, metal badges or objects. Vehicle front protectors and aftermarket lights may also block the sensor.

Cruise Control

The following table lists possible causes and actions for this message displaying.

Cause	Action
The surface of the radar in the grille is dirty or obstructed in some way.	Clean the grille surface in front of the radar or remove the object causing the obstruction.
The surface of the radar in the grille is clean but the message remains in the display.	Wait a short time. It may take several minutes for the radar to detect that it is free from obstruction.
Heavy rain or snow is interfering with the radar signals.	Do not use the system in these conditions because it may not detect any vehicles ahead.
Swirling water, snow or ice on the surface of the road may interfere with the radar signals.	Do not use the system in these conditions because it may not detect any vehicles ahead.

It is possible to get a blockage warning and not be blocked. A false blocked condition self clears or clears after a key cycle.

Switching to Normal Cruise Control

WARNING



Normal cruise control does not brake due to slower vehicles. Always be aware of which mode you have selected and apply the brakes when necessary.

You can manually change from adaptive cruise control to normal cruise control through the information display.



The cruise control indicator light replaces the adaptive cruise control indicator light if you select normal cruise control. The gap setting does not display, the system does not automatically respond to lead vehicles and automatic braking does not activate. The system remembers the last setting when you start your vehicle.

Driving Aids

SPEED LIMITER

Principle of Operation

WARNING



When you are going downhill, your vehicle speed may increase above the set speed. The system will not apply the brakes but a warning displays.

The system allows you to set a speed to which your vehicle becomes limited. The set speed sets the effective maximum speed of your vehicle. You can temporarily exceed the set speed if required, for example to overtake.

Using the System

Note: If you briefly press the accelerator, for example when overtaking another vehicle, the system temporarily turns off.

The system is operated by the controls mounted on the steering wheel.

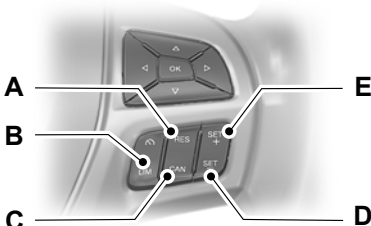

E200786

- A Resume.
- B On and off.
- C Cancel.
- D Set speed decrease.
- E Set speed increase.

Switching the System On and Off

Press switch **B**. The information display will prompt you to set a speed.

Setting the Speed Limiter

Use the cruise control switches to adjust the maximum speed setting.

Press switch **E** or **D** to select your desired speed limit. The set speed is stored and displayed in the information display.

Press switch **C** to cancel the limiter and place it in standby mode. The information display will confirm the system is in standby mode by displaying the set speed limit as crossed out.

Press switch **A** again to resume the limiter. The information display will confirm this has been turned on by showing the set speed again.

Intentionally Exceeding the Speed Limiter Set Speed

Depress the accelerator fully to temporarily turn the system off. The speed limiter set speed resumes when your vehicle speed drops below the set speed limit.

System Warnings

If you unintentionally exceed the set speed, a warning will flash in the information display and a warning chime will sound.

If you intentionally exceed the set speed, a warning will flash in the information display.

DRIVER ALERT (If Equipped)

Principle of Operation

WARNINGS



The system does not relieve you of your responsibility to drive with due care and attention.

Driving Aids

WARNINGS



At all times you are responsible for controlling your vehicle, supervising the system and intervening if required.



If the sensor becomes blocked the system may not function.



Take regular rest breaks as required and do not wait for the system to warn you if you feel tired.



Take rest breaks only where it is safe to do so.



Certain driving styles and behavior may result in the system issuing a warning even if you are not feeling tired.



In cold and severe weather conditions the system may not function. Rain, snow, spray and large contrasts in lighting can all influence the sensor.



The system will not operate if the sensor cannot track the road lane markings.



The system may not operate in areas during roadwork construction.



The system may not operate on roads with sharp bends or narrow lanes.



Do not carry out windshield repairs in the immediate area surrounding the sensor.



If your vehicle has a suspension kit not approved by us, the system may not function correctly.

Note: *Keep the windshield free from obstructions such as bird droppings, insects and snow or ice.*

Note: *The system assists you when driving on fast main roads and freeways.*

Note: *The system calculates an alertness level at vehicle speeds above approximately 65 km/h.*

The system automatically monitors your driving behavior.

The system is designed to alert you if it detects that you are becoming drowsy or if your driving deteriorates.

Using Driver Alert

Switching the System On and Off

Note: *The system will remain on or off depending on how it was last set.*

Switch the system on using the information display. See **Information Displays** (page 67).

The system will calculate your alertness level based upon your driving behavior in relation to the lane markings and other factors.

System Warnings

Note: *The system will not issue warnings below approximately 65 km/h.*

The warning system has two stages:

1. A temporary warning is issued to advise you to take a rest. This message only appears for a short time.
2. If you do not rest and the system continues to detect that your driving deteriorates, it will issue a driving warning. This will remain in the information display until you cancel it. See **Information Messages** (page 76).

Press **OK** on the steering wheel control to remove the warning.

Driving Aids

System Display

When active the system will run automatically in the background and only issue warnings if required. You can view the status at any time using the information display. See **General Information** (page 67).

The alertness level is shown by six steps as a colored bar.

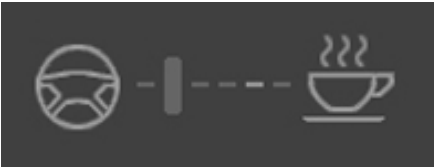

E131358

Alertness level is fine, no rest required.

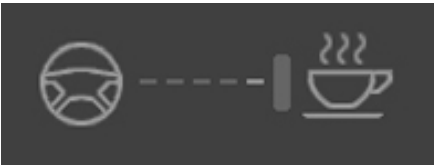

E131359

Alertness level is critical, indicating that you should take a rest as soon as it is safe to do so.

The status bar will travel from left to right as the calculated alertness level decreases. As the rest icon is approached the color turns from green to yellow and then finally red when a rest break must be taken.

- Green: No rest required.
- Yellow: First (temporary) warning.
- Red: Second warning.

Your alertness level will be shown in grey if:

- the camera sensor cannot track the road lane markings
- your vehicle speed drops below approximately 65 km/h.

Resetting the System

You can reset the system by:

- switching the ignition off and on
- stopping your vehicle and then opening and closing the driver's door.

LANE KEEPING SYSTEM (if

Equipped)

WARNINGS



The system does not relieve you of your responsibility to drive with due care and attention.



At all times you are responsible for controlling your vehicle, supervising the system and intervening if required.



If the sensor becomes blocked the system may not function.



In cold and severe weather conditions the system may not function. Rain, snow, spray can all limit sensor performance.



Large contrasts in lighting can limit sensor performance.



The system will not operate if the sensor cannot track the road lane markings.



The vehicle should be taken to an authorized dealer for inspection if damage occurs in the immediate area surrounding the sensor.

Driving Aids

Note: The system is activated at speeds above 64 km/h.

Note: The system works as long as the camera can detect one lane marking.

Note: The system may not function if the camera is blocked or there is damage to the windshield.

Note: When Aid mode is on and the system detects no steering activity for a short period, the system will alert you to put your hands on the steering wheel. The system may detect a light grip or touch on the steering wheel as hands off driving.

The system notifies you to stay in your lane through the steering system and the instrument cluster display when the front camera detects an unintentional drift out of your lane is likely to occur. The system automatically detects and tracks the road lane markings using a camera mounted behind the interior rear view mirror.

Switching the System On and Off

Note: The system on or off setting is stored until it is manually changed, unless a MyKey is detected. If the system detects a MyKey it defaults to on and the mode is set to Alert.

Note: If a MyKey is detected, pressing the button will not affect the on or off status of the system.



Press the button located on the left steering wheel stalk to switch the system on or off.

System Settings

The system has optional setting menus available. To view or adjust the settings, See **General Information** (page 67). The system stores the last-known selection for each of these settings. You do not need to readjust your settings each time you turn on the system.

Mode: This setting allows you to select which of the system features you can enable.

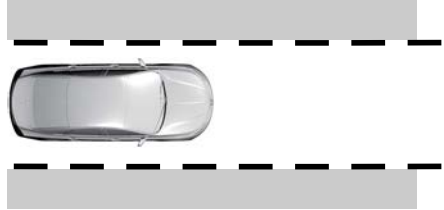

E165515

Alert only – Provides a steering wheel vibration when the system detects an unintended lane departure.

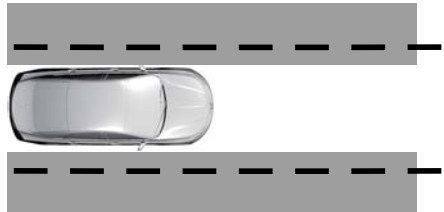

E165516

Aid only – Provides an assistance steering torque input toward the lane center when the system detects an unintended lane departure.

Driving Aids

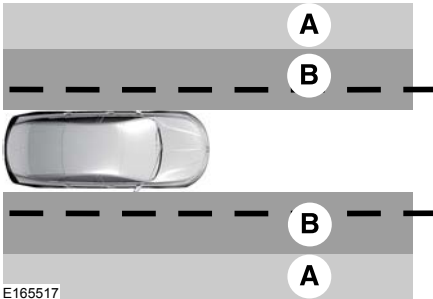

A Alert.

B Aid.

Alert + Aid – Provides an assistance steering torque input toward the lane center. If your vehicle continues drifting out of the lane, the system provides a steering wheel vibration.

Note: *The alert and aid diagrams illustrate general zone coverage. They do not provide exact zone parameters.*

Intensity: This setting affects the intensity of the steering wheel vibration used for the alert and alert + aid modes. This setting does not affect the aid mode.

- Low.
- Normal.
- High.

System Display



When you switch on the system, an overhead graphic of a vehicle with lane markings will display in the information display. If you select aid mode when you switch on the system, a separate white icon will also appear or in some vehicles arrows will display with the lane markings.

When you switch off the system, the lane marking graphics will not display.

While the system is on, the color of the lane markings will change to indicate the system status.

Gray: Indicates that the system is temporarily unable to provide a warning or intervention on the indicated side(s). This may be because:

- Your vehicle is under the activation speed.
- The turn indicator is active.
- Your vehicle is in a dynamic maneuver.

Driving Aids

- The road has no or poor lane markings in the camera field-of-view.
- The camera is obscured or unable to detect the lane markings due to environmental conditions (significant sun angles, shadows, snow, heavy rain or fog), traffic conditions (following a large vehicle that is blocking or shadowing the lane), or vehicle conditions (poor headlamp illumination).

See **Troubleshooting** for additional information.

Green: Indicates that the system is available or ready to provide a warning or intervention, on the indicated side(s).

Troubleshooting

Why is the feature not available (line markings are gray) when I can see the lane markings on the road?
Vehicle speed is outside the operational range of the feature
Sun is shining directly into the camera lens
Quick intentional lane change
Staying too close to the lane marking
Driving at high speeds in curves
The last Alert warning or Aid intervention occurred a short time ago
Ambiguous lane markings (mainly in construction zones)
Rapid transition from light to dark or vice versa
Sudden offset in lane markings
ABS or activation
Camera blockage due to dirt, grime, fog, frost or water on the windshield
Driving too close to the vehicle in front of you
Transitioning between no lane markings to lane markings or vice versa
Standing water on the road
Faint lane markings (partial yellow lane markings on concrete roads)

Yellow: Indicates that the system is providing or has just provided a lane keeping aid intervention.

Red: Indicates that the system is providing or has just provided a lane keeping alert warning.

The system can be temporarily suppressed at any time by the following:

- Quick braking.
- Fast acceleration.
- Using the turn signal indicator.
- Evasive steering maneuver.

Driving Aids

Why is the feature not available (line markings are gray) when I can see the lane markings on the road?

Lane width too narrow or too wide

Camera not calibrated after a windshield replacement

Driving on tight roads or on uneven roads

Why does the vehicle not come back toward the middle of the lane, as expected, in the Aid or Aid + Alert mode?

High cross winds

Large road crown

Rough roads, grooves, shoulder drop-offs

Heavy uneven loading of the vehicle or improper tire inflation pressure

If the tires have been exchanged (including snow tires), or the suspension has been modified

BLIND SPOT INFORMATION SYSTEM

Blind Spot Information System (BLIS™) with Cross Traffic Alert

WARNING



To help avoid injuries, NEVER use the Blind Spot Information System as a replacement for using the interior and exterior mirrors and looking over your shoulder before changing lanes. The Blind Spot Information System is not a replacement for careful driving.

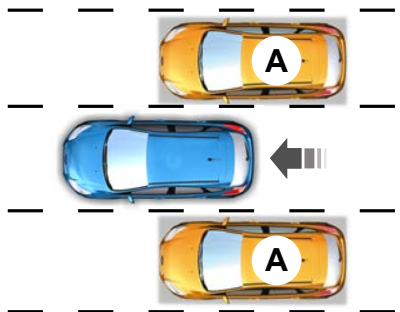

E124788

The Blind Spot Information System aids you in detecting vehicles that may have entered the blind spot zone (A). The detection area is on both sides of your vehicle, extending rearward from the exterior mirrors to approximately 7 m beyond the bumper. The system alerts you if certain vehicles enter the blind spot zone while driving.

Driving Aids

WARNING



To help avoid personal injury, NEVER use the cross traffic alert system as a replacement for using the interior and exterior mirrors and looking over your shoulder before backing out of a parking space. Cross traffic alert is not a replacement for careful driving.

Cross traffic alert warns you of vehicles approaching from the sides when the transmission is in reverse (R).

Note: *The Blind Spot Information System does not prevent contact with other vehicles or objects; nor does it detect parked vehicles, people, animals or infrastructure (fences, guardrails or trees). It only alerts you to vehicles in the blind zones.*

Note: *When a vehicle passes quickly through the blind zone, the system may not trigger.*

Using the Systems

The Blind Spot Information System turns on when you start the engine and you drive your vehicle forward above 8 km/h, it remains on while the transmission is in drive (D) or neutral (N). If shifted into reverse (R), the system enters cross traffic alert mode. Once shifted back into drive (D), the Blind Spot Information System turns back on when you drive your vehicle above 8 km/h.

Note: *The Blind Spot Information System does not function in reverse (R) or park (P).*

Note: *Cross traffic alert detects approaching vehicles and bicycles from up to 40 m away though coverage decreases when the sensors are blocked. Reversing slowly helps increase the coverage area and effectiveness.*

Note: *The cross traffic alert will be active only if the transmission is in reverse (R). If your vehicle is rolling backward and the transmission is not in reverse (R) then cross traffic alert will not be active.*

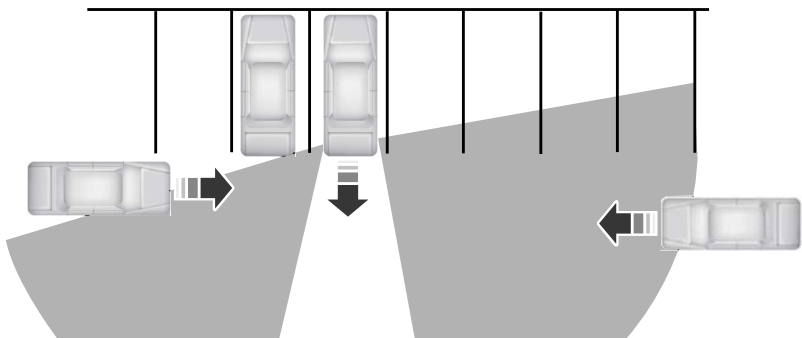

E142440

Driving Aids

In this first example, the left sensor is only partially obstructed; zone coverage is nearly maximized.

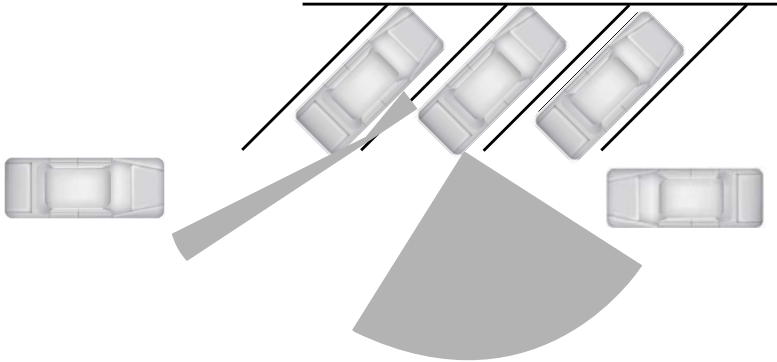

E142441

Zone coverage also decreases when parking at shallow angles. Here, the left sensor is mostly obstructed; zone coverage on that side is severely limited.

System Lights and Messages

The Blind Spot Information and cross traffic alert systems illuminate a yellow alert indicator in the outside mirror on the side of your vehicle the approaching vehicle is coming from. In addition, the yellow alert indicator will flash if the direction indicator is ON while a Blind Spot Warning System alert is active.

Note: *The alert indicator dims when the system detects night time darkness.*

Cross traffic alert also sounds a series of tones and a message appears in the information display indicating a vehicle is coming from the right or left.



E142442

Driving Aids

System Sensors

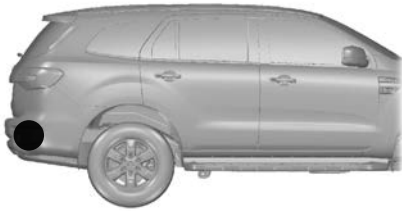

E221263

WARNING



Just prior to the system recognizing a blocked condition and alerting the driver, the number of missed objects will increase. To help avoid injuries, NEVER use the Blind Spot Information System as a replacement for using the side and rear view mirrors and looking over your shoulder before changing lanes. The Blind Spot Information System is not a replacement for careful driving.

Note: *It is possible to get a blockage warning with no blockage present; this is rare and known as a false blockage warning. A false blocked condition either self-corrects or clears after a key cycle.*

The system uses radar sensors which are located behind the bumper fascia on each side of your vehicle. Do not allow mud, snow or bumper stickers to obstruct these areas, this can cause degraded system performance.

If the system detects a degraded performance condition, a message warning of a blocked sensor or low visibility will appear in the information display along with a warning indicator. You can clear the information display warning but the warning indicator will remain illuminated.

When you remove a blockage, you can reset the system in two ways:

- While driving, the system detects at least two objects.
- You cycle the ignition from on to off and then back on.

If the blockage is still present after the key cycle and driving in traffic, check again for a blockage.

Reasons for messages being displayed

The radar surface is dirty or obstructed	Clean the fascia area in front of the radar or remove the obstruction.
The radar surface is not dirty or obstructed	Drive normally in traffic for a few minutes to allow the radar to detect passing vehicles so it can clear the blocked state.
Heavy rainfall or snowfall interferes with the radar signals	No action required. The system automatically resets to an unblocked state once the rainfall or snowfall rate decreases or stops. Do not use the Blind Spot Information System or cross traffic alert in these conditions.

System Limitations

The Blind Spot Information and cross traffic alert systems do have their limitations; situations such as severe weather conditions or debris build-up on the sensor area may limit vehicle detection.

The following are other situations that may limit the Blind Spot Information System:

- Vehicles passing through the blind zone at very quickly.
- When several vehicles closely following each other pass through the blind zone.

Driving Aids

The following are other situations that may limit the cross traffic alert system:

- Adjacently parked vehicles or objects obstructing the sensors.
- Approaching vehicles passing at speeds greater than 60 km/h.
- Driving in reverse faster than 12 km/h.
- Backing out of an angled parking spot.

False Alerts

Note: *If your vehicle has a factory equipped tow bar and it is towing a trailer, the sensors will detect the trailer and turn the Blind Spot Information and cross traffic alert systems off to avoid false alerts. For non-factory equipped tow bars, you may want to switch the Blind Spot Information System off manually.*

There may be certain instances when there is a false alert by either the Blind Spot Information or the cross traffic alert system that illuminates the alert indicator with no vehicle in the coverage zone. Some amount of false alerts are normal; they are temporary and self-correct.

System Errors

If either system senses a problem with the left or right sensor, the Blind Spot Information System telltale will illuminate and a message will appear in the information display.

All other system faults will display only with a message in the information display. See **Information Messages** (page 76).

Switching the Systems Off and On

You can temporarily switch off one or both systems in the information display. When you switch off the Blind Spot Information System, you will not receive alerts and the information display shows a system off message.

Note: *The cross traffic alert system always turns on whenever the ignition is switched on. However, the Blind Spot Information System will remember the last selected on or off setting.*

You cannot switch one or both systems off when MyKey is used.

You can also have one or both systems switched off permanently at an authorized dealer. Once switched off, only an authorized dealer can switch the system back on.

STEERING

Electric Power Steering

WARNINGS



The electric power steering system has diagnostic checks that continuously monitor the system. If a fault is detected, a message displays in the information display. Stop your vehicle as soon as it is safe to do so. Switch the ignition off. After at least 10 seconds, switch the ignition on and watch the information display for a steering system warning message. If a steering system warning message returns, have the system checked by an authorized dealer.



If the system detects an error, you may not feel a difference in the steering, however a serious condition may exist. Obtain immediate service from an authorized dealer, failure to do so may result in loss of steering control.

Your vehicle has an electric power steering system. There is no fluid reservoir. No maintenance is required.

Driving Aids

If your vehicle loses electrical power while you are driving, electric power steering assistance is lost. The steering system still operates and you can steer your vehicle manually. Manually steering your vehicle requires more effort.

Extreme continuous steering may increase the effort required for you to steer your vehicle. This increased effort prevents overheating and permanent damage to the steering system. You do not lose the ability to steer your vehicle manually. Typical steering and driving maneuvers allow the system to cool and return to normal operation.

Steering Tips

If the steering wanders or pulls, check for:

- Correct tire pressures.
- Uneven tire wear.
- Loose or worn suspension components.
- Loose or worn steering components.
- Improper vehicle alignment.

Note: A high crown in the road or high crosswinds may also make the steering seem to wander or pull.

Adaptive Learning

The electronic power steering system adaptive learning helps correct road irregularities and improves overall handling and steering feel. It communicates with the brake system to help operate advanced stability control and accident avoidance systems. Additionally, whenever the battery is disconnected or a new battery installed, you must drive your vehicle a short distance before the system relearns the strategy and reactivates all systems.

PRE-COLLISION ASSIST

WARNINGS



This system is an extra driving aid. It does not replace your attention and judgment, or the need to apply the brakes. This system does NOT automatically brake your vehicle. If you fail to press the brake pedal when necessary, you may collide with another vehicle.



The Pre-Collision Assist system with brake support cannot help prevent all collisions. Do not rely on this system to replace your judgment and the need to maintain correct distance and speed.

Note: The system does not detect, warn or respond to potential collisions with vehicles to the rear or sides of your vehicle.

Note: The Pre-Collision Assist system is active at speeds above approximately 5 km/h.



E156130

The system alerts you of certain collision risks. The system's sensor detects your vehicle's rapid approach to other vehicles traveling in the same direction as your vehicle.

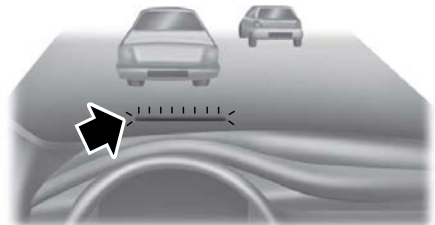

E156131

Driving Aids

When your vehicle rapidly approaches another vehicle, a red light bar flashes in the windscreen (refer to image), a warning lamp with the words "Pre-collision Assist" is displayed in the instrument cluster and a tone sounds.

The brake support system assists you in reducing any collision speed by pre-charging the brakes. If the risk of collision continues to increase after the audio-visual warning, the brake support prepares the brake system for rapid braking. The system does not automatically activate the brakes, but can provide supplementary braking power if the brake pedal is pressed even lightly.

Using the Pre-Collision Assist System

WARNING



The Pre-Collision Assist system's brake support reduces collision speed only if you brake your vehicle before any collision. You must press your brake pedal as you would in any typical braking situation.

You can adjust the warning system's sensitivity through your information display. See **General Information** (page 67).

Note: When possible, the manufacturer recommends using the highest sensitivity setting. If warnings are too frequent, you can reduce your system's sensitivity. Reduced sensitivity causes fewer and later system warnings. See **General Information** (page 67).

Distance Alert

If the system detects that your vehicle is too close to the vehicle in front based on the current sensitivity setting (see Adjusting Pre-Collision Assist Settings section below) the centre section of the red light bar in the windscreen will illuminate (refer to image).

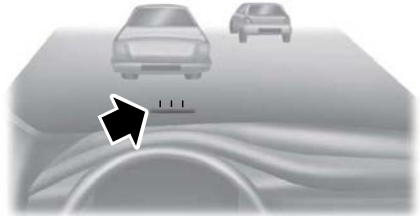

E184570

Distance Indication

Distance indication is a function that provides a graphical indication of the time gap to other vehicles traveling in the same direction.

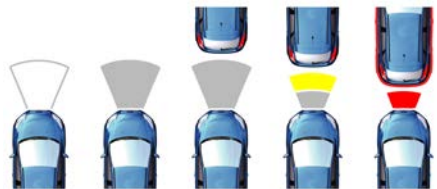

E190004

Note: Distance Alert and Distance Indication deactivates when adaptive cruise control is active. The distance indication graphics do not display in the information display unless adaptive cruise control is OFF.

Driving Aids

Speed	Sensitivity	Graphics	Distance Gap	Time Gap
62mph (100km/h)	Normal	Grey	>25m	>0.9sec
62mph (100km/h)	Normal	Yellow	between 17m and 25m	between 0.6sec and 0.9sec
62mph (100km/h)	Normal	Red	<17m	<0.6sec

Adjusting Pre-Collision Assist Settings

You can adjust the Pre-Collision Assist and Distance Alert sensitivity to one of three possible settings by using the information display control. See **General Information** (page 67).

You can switch the distance alert and indication function off using the information display controls. See **General Information** (page 67).

Blocked Sensors



E223376

If a blocked sensor message appears in the information display, dirt, water, or an object is blocking the sensor. The sensor is located behind a cover near the driver side of the lower grille. If anything blocks the sensor, your vehicle cannot see through the sensor, and the pre-collision assist system will not work. Possible causes for the blocked sensor message and corrective actions are listed below.

Driving Aids

Cause	Action
The radar sensor cover in the grille is dirty or obstructed	Clean the radar sensor cover or remove the obstruction
The surface of the radar sensor cover is clean but the message remains in the display	Wait a short time. The radar may take several minutes to reset after you remove the obstruction
Heavy rain, spray, snow or fog in the air interferes with the radar signals	The Pre-Collision Assist system is temporarily disabled. Shortly after weather conditions improve, the collision warning system automatically reactivates
Swirling water, snow or ice on the road surface interferes with the radar signals	The Pre-Collision Assist system is temporarily disabled. Shortly after weather conditions improve, the collision warning system automatically reactivates

System Limitations

WARNING



The Pre-Collision Assist system's brake support reduces collision speed only if you brake your vehicle before any collision. You must press your brake pedal as you would in any typical braking situation.

- Small distance to vehicle ahead.
- Large steering wheel and pedal movements (very active driving style).

Damage to the front end of your vehicle may alter the radar sensor's coverage area. This may result in missed or false collision warnings. Have an authorized dealer check your radar sensor for proper coverage and operation.





Due to the nature of radar technology, there may be certain instances where vehicles do not provide a collision warning. These include:

- Stationary vehicles or slow moving vehicles.
- Pedestrians or objects in the roadway.
- Oncoming vehicles in the same lane.
- Severe weather conditions (see blocked sensor section).
- Debris build-up on the grille near the headlamps (see blocked sensor section).



Load Carrying

GENERAL INFORMATION

WARNINGS

-  Use load securing straps to an approved standard, e.g. DIN.
-  Make sure that you secure all loose items properly.
-  Place luggage and other loads as low and as far forward as possible within the luggage or loadspace.
-  Do not exceed the maximum front and rear axle loads for your vehicle.

WARNINGS

-  Do not exceed the maximum gross vehicle weight.
-  Do not place solid objects outside the loadspace area for example timber and sheet material.

Note: *The center of the payload should be located within the wheelbase of the vehicle.*

Note: *Avoid one sided load distribution.*

Note: *Uneven load distribution could result in unacceptable handling and braking characteristics.*

ROOF RACKS AND LOAD CARRIERS

Load Carrying - Roof Loads

Drive Type	17" Wheel	18"Wheel	20"Wheel	With Moonroof (all wheel sizes)
All-Wheel Drive	100 kg	100 kg	100 kg	80 kg
Rear Wheel Drive	100 kg	100 kg	60 kg	30 kg

Towing

TOWING A TRAILER

WARNINGS



Do not exceed 62 mph (100 km/h).



Do not exceed the maximum permissible gross train weight stated. See **Recommended Towing Weights** (page 171).



Do not exceed the maximum permissible nose weight, e.g. vertical weight on the tow ball. See

Recommended Towing Weights (page 171).



Do not exceed the maximum permissible axle load stated on your vehicle identification plate.



The anti-lock braking system does not control the overrun brake on the trailer.

Note: *Vehicles equipped with electronic stability program (ESP) have trailer stability control included.*

When towing a trailer:

- Obey country specific regulations for towing a trailer.
- Do not exceed 100 km/h even if a country allows higher speeds under certain conditions.
- Place loads as low as possible and central to the axle of your trailer. For best stability of the trailer in an unladen vehicle, place the load in the trailer towards the nose within the maximum nose load as this gives the best stability. See **Recommended Towing Weights** (page 171).

- Reduce the stipulated maximum permitted gross train weight by 10% for every additional 1,000 m in high altitude regions above 1,000 m.
- Use a low gear when descending a steep downhill gradient.

The stability of your vehicle to trailer combination is very much dependent on the quality of the trailer.

Trailer Tow Module

WARNINGS



Do not connect the trailer patch harness to the vehicle when the trailer is not connected.



Make sure that the indicator and brake lamps do not flicker with engine running while using a trailer with low power LED lamps.

Vehicles with factory fitted tow bar include a trailer plug control module for trailer lighting. Along with trailer plug functionality, it also protects the vehicle's primary electrical circuits and some trailer electrical failures.

You can purchase a trailer tow kit from an authorized dealer for the vehicles without factory fitted tow bar. This enables the tow bar installation.

The kit includes:

- Trailer plug
- Wiring and hardware components
- Trailer plug control module

Note: *Have the trailer tow electrical kit configured by an authorized dealer.*





Connect a trailer patch harness between the trailer and the vehicle to overcome flickering and correct operation of the rear parking aid.

Note: *The trailer patch harness is available with the Ford authorized dealer.*

Towing

TOW BALL

WARNINGS

-  Never leave the detached tow ball assembly unsecured inside the vehicle. This would increase the risk of injury in an accident.
-  When not in use, remove the tow ball assembly from the vehicle.
-  Take special care when fitting the tow ball assembly as the safety of the vehicle and the trailer depends on this.
-  Do not modify the trailer coupling.
-  Do not disassemble, repair or modify the tow ball assembly.

Tow Ball Hitch Assembly

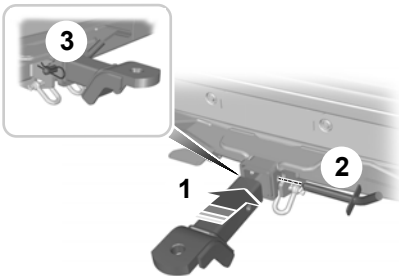



E207959

1. Insert the tow ball assembly into the hitch box.
2. Insert the hitch pin.
3. Secure the hitch pin in place with the R-clip.

Driving with a trailer

WARNINGS

-  If any of the following conditions cannot be met, do not use the tow bar and have it inspected by properly trained technicians.
-  To avoid risk of injury, never remove the tow ball assembly with the trailer attached.

Before starting your journey

- Depending on the tow ball assembly (Type 1, 2 or 3) confirm that it is correctly engaged and locked in place.
- Install the plug into its seat.

WARNING

-  Tow coupling anti-rattle pinch bolt (where fitted) should be removed from towbar when towing. When not towing, the anti-rattle pinch bolt should be replaced, and lock nut tightened. Tightening torque must not exceed 47 Nm.

Anti-rattle pinch bolt removal

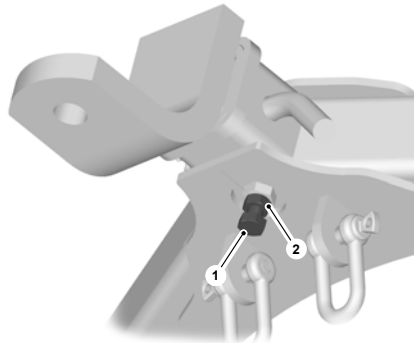

E208167

Towing

Remove the tow coupling anti-rattle pinch bolt (1) by loosening the pinch bolt lock nut (2).

Driving without a trailer

1. Remove the tow ball assembly from the vehicle.

Maintenance

Keep the system clean.

Periodically lubricate the tow ball mechanism with resin-free grease or oil.

Lubricate any tow ball assembly locking mechanisms with graphite.

TRAILER SWAY CONTROL

Note: The system automatically turns on every time you switch the ignition on.

Note: Switching off the stability control will turn off the system.

Note: This feature does not prevent trailer sway, but reduces it once it begins.

Note: This feature cannot stop all trailers from swaying.

Trailer sway control is an enhanced feature of stability control system and automatically detects when an attached trailer starts to sway. This feature applies your vehicle brakes at individual wheels and if necessary, reduces engine power. If the trailer begins to sway, slow your vehicle down, pull safely to the side of the road and check for correct load distribution. See **Towing a Trailer** (page 169).

Note: Shifting to 4x4 Low will deactivate trailer sway control.

Note: Switching on the electronic locking differential will turn off the system.

Note: To switch off the trailer sway control as required, See **Stability Control** (page 134).

RECOMMENDED TOWING WEIGHTS

Towing capacities

Variant	Drive	Transmission	With Trailer Brake	Max. Gross Train Weight
2.2L Diesel	4X2*	Manual	3,000 kg	5,700 kg
	4X2*	Auto	3,000 kg	5,700 kg
	AWD	Manual	3,000 kg	5,800 kg
3.2L Diesel	AWD	Auto	3,000 kg	5,800 kg

*Vehicles with increased ride height.

Trailer Nose Weight

WARNING



Do not exceed the maximum permissible nose weight, e.g. vertical weight on the tow ball. This is important for vehicle and trailer stability.

Towing

Drive	Minimum Nose Weight	Maximum Nose Weight
4x2 * and AWD	10% of the towed weight	300 kg
		300 kg

*Vehicles with increased ride height.

Towing

ESSENTIAL TOWING CHECKS

Follow these guidelines for safe towing:

- Do not tow a trailer until you drive your vehicle at least 1,600 km
- Consult your local motor vehicle laws for towing a trailer.
- See the instructions included with towing accessories for the proper installation and adjustment specifications.
- Service your vehicle more frequently if you tow a trailer. See your scheduled maintenance information.
- If you use a rental trailer, follow the instructions the rental agency gives you.

You can find information on load specification terms found on the tire label and Safety Compliance label as well as instructions on calculating your vehicle's load in the Load Carrying chapter. See **Recommended Towing Weights** (page 171).

Remember to account for the trailer nose weight as part of your vehicle load when calculating the total vehicle weight.

Hitches

Do not use a hitch that either clamps onto the bumper or attaches to the axle.

Distribute the trailer load so that 10-15% of the total trailer weight is on the tongue.

Weight-distributing Hitches

WARNING



Do not adjust a weight-distributing hitch to any position where the rear bumper of the vehicle is higher than it was before attaching the trailer. Doing so will defeat the function of the weight-distributing hitch, which may cause unpredictable handling, and could result in serious personal injury.

When hooking-up a trailer using a weight-distributing hitch, always use the following procedure:

1. Park the loaded vehicle, without the trailer, on a level surface.
2. Measure the height to the top of your vehicle's front wheel opening on the fender. This is H1.
3. Attach the loaded trailer to your vehicle without the weight-distributing bars connected.
4. Measure the height to the top of your vehicle's front wheel opening on the fender a second time. This is H2.
5. Install and adjust the tension in the weight-distributing bars so that the height of your vehicle's front wheel opening on the fender is approximately half the way down from H2, toward H1.
6. Check that the trailer is level or slightly nose down toward your vehicle. If not, adjust the ball height accordingly and repeat Steps 2-6.

When the trailer is level or slightly nose down toward the vehicle:

- Lock the bar tension adjuster in place.
- Check that the trailer tongue securely attaches and locks onto the hitch.
- Install safety chains, lighting, and trailer brake controls as required by law or the trailer manufacturer.

Towing

Safety Chains

Note: *Never attach safety chains to the bumper.*

Always connect the safety chains to the hook retainers of your vehicle hitch.

To connect the trailer's safety chains, cross them under the trailer tongue and allow enough slack for turning tight corners. Do not allow the chains to drag on the ground.

Trailer Brakes

WARNING



Do not connect a trailer's hydraulic brake system directly to your vehicle's brake system. Your vehicle may not have enough braking power and your chances of having a collision greatly increase.

Electric brakes and manual, automatic or surge-type trailer brakes are safe if you install them properly and adjust them to the manufacturer's specifications. The trailer brakes must meet local and federal regulations.

The rating for the tow vehicle's braking system operation is at the gross vehicle weight rating, not the gross combined weight rating.

Separate functioning brake systems are required for safe control of towed vehicles and trailers weighing more than 680 kg when loaded.

Trailer Lamps

WARNING



Never connect any trailer lamp wiring to the vehicle's tail lamp wiring; this may damage the electrical system resulting in fire. Contact your authorized dealer as soon as possible for assistance in proper trailer tow wiring installation. Additional electrical equipment may be required.

Trailer lamps are required on most towed vehicles. Make sure all running lights, brake lights, turn signals and hazard lights are working.

Before Towing a Trailer

Practice turning, stopping and backing up to get the feel of your vehicle-trailer combination before starting on a trip. When turning, make wider turns so the trailer wheels clear curbs and other obstacles.

When Towing a Trailer

Note: *Only use the trailer hitch anti-rattle bolt when NOT towing a trailer.*

- Do not drive faster than 100 km/h during the first 800 km.
- Do not make full-throttle starts.
- Check your hitch, electrical connections and trailer wheel lug nuts thoroughly after you have traveled 80 km.
- When stopped in congested or heavy traffic during hot weather, place the gearshift in position park (P) to aid engine and transmission cooling and to help A/C performance.
- Turn off the speed control with heavy loads or in hilly terrain. The speed control may turn off automatically when you are towing on long, steep grades.

Towing

- Shift to a lower gear when driving down a long or steep hill. Do not apply the brakes continuously, as they may overheat and become less effective.
- If your transmission is equipped with a Grade Assist or Tow/Haul feature, use this feature when towing. This provides engine braking and helps eliminate excessive transmission shifting for optimum fuel economy and transmission cooling.
- Allow more distance for stopping with a trailer attached. Anticipate stops and brake gradually.
- Avoid parking on a grade. However, if you must park on a grade:
 1. Turn the steering wheel to point your vehicle tires away from traffic flow.
 2. Set your vehicle parking brake.
 3. Place the automatic transmission in position park (P).
 4. Place wheel chocks in front and back of the trailer wheels. (Chocks not included with vehicle.)

Launching or Retrieving a Boat or Personal Watercraft (PWC)

Note: Disconnect the wiring to the trailer **before** backing the trailer into the water.

Note: Reconnect the wiring to the trailer **after** removing the trailer from the water.

When backing down a ramp during boat launching or retrieval:

- Do not allow the static water level to rise above the bottom edge of the rear bumper.
- Do not allow waves to break higher than 15 cm above the bottom edge of the rear bumper.

Exceeding these limits may allow water to enter vehicle components:

- Causing internal damage to the components.
- Affecting driveability, emissions, and reliability.

Replace the rear axle lubricant anytime the rear axle has been submerged in water. Water may have contaminated the rear axle lubricant, which is not normally checked or changed unless a leak is suspected or other axle repair is required.

TOWING POINTS

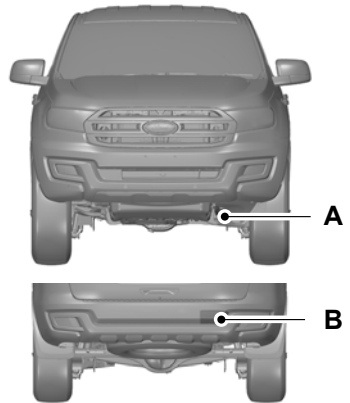

E203454

A Front towing eye.

B Rear towing eye.*

* Remove the cover to access the towing eye.

Towing

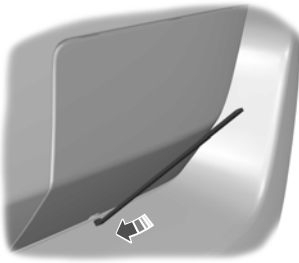





E221577

Use the towing eye cover removal tool (provided in the vehicle tool kit) to carefully remove the towing eye cover by pulling rearward.

TOWING THE VEHICLE ON FOUR WHEELS

All Vehicles

WARNINGS

-  Switch the ignition on when towing the vehicle.
-  The brake and steering assistance will not operate unless the engine is running. Press the brake pedal harder and allow for increased stopping distances and heavier steering.
-  Too much tension in the tow rope could cause damage to your vehicle or the vehicle that is towing.
-  Do not use a rigid tow bar on the front towing eye.
-  When towing a 2WD vehicle you must select neutral.





WARNINGS

-  Do not tow the vehicle with all wheels on the ground while in AWD mode. Tow your vehicle with all wheels off the ground or all wheels on the ground while the vehicle is in 2WD mode in an event of a breakdown or mechanical failure of the transmission.

Drive off slowly and smoothly without jerking the vehicle you are towing.

Vehicles With Automatic Transmission

WARNINGS

-  If a speed of 20 km/h and a distance of 20 km is to be exceeded the drive wheels must be lifted clear of the ground.
-  It is recommended not to tow with the drive wheels on the ground. However, if it is required to move your vehicle from a dangerous location, do not tow your vehicle faster than 20 km/h or further than 20 km.
-  Do not tow your vehicle backward.
-  In the event of a mechanical failure of the transmission the drive wheels must be lifted clear of the ground.
-  Do not tow your vehicle if the ambient temperature is below 0°C.

Driving Hints

BREAKING-IN

Tires

WARNING



New tires need to be run-in for approximately 500 km. During this time, you may experience different driving characteristics.

Brakes and Clutch

WARNING



Avoid heavy use of the brakes and clutch if possible for the first 160 km in town and for the first 1,600 km on freeways.

Engine

WARNING



Avoid driving too fast during the first 1,600 km. Vary your speed frequently and change up through the gears early. Do not labour the engine.

Vehicles With a Diesel Engine

During the first 3,200 km, you may notice a ticking sound when your vehicle slows down. This is due to adjustments of your new diesel engine and is normal.

REDUCED ENGINE PERFORMANCE

WARNING



Continued operation of an overheating engine will increase the temperature further, and cause the engine to shut down completely.

Drive the overheating engine only for a brief amount of time to prevent permanent damage. The engine will continue to operate with limited power. The distance you can travel depends on ambient temperature, vehicle load, and terrain.

If the needle in the engine coolant temperature gauge moves to the upper limit position, the engine is overheating. See **Gauges** (page 59).

If the engine temperature continues to rise, the fuel supply to the engine will reduce. The air conditioning will also turn off and the engine cooling fan will operate.

When this happens, immediately:

- Stop your vehicle as soon as possible.
- Turn off the engine to prevent severe engine damage.
- Wait for the engine to cool down.
- Check the coolant level. See **Engine Coolant Check** (page 205).
- Have the vehicle checked by an authorized dealer.

OFF-ROAD DRIVING

WARNING



Off-road driving can be extremely dangerous and carries inherent risks that may not be preventable even with the best precautions. Ford strongly recommends driving within your ability and taking every safety precaution.

In addition to providing an excellent on-road driving experience, your vehicle also excels at all types of off-road driving. The vehicle has been designed and equipped to allow you to explore those places where the road doesn't take you, whether it's a forest trail or the open desert. Before going off road driving,

Driving Hints

consult with your local governmental agencies to determine designated off-road trails and recreation areas. Also, be sure to understand any off-road vehicle registration requirements for the area in which you plan on driving.

Before taking your vehicle off-road driving, a basic vehicle inspection should be done to make sure that the vehicle is in top working condition.

It is always recommended that at least two vehicles are used while off road driving. Using two vehicles in "buddy" system helps make sure that help is close at hand should a vehicle become stuck or damaged. It is also wise to take supplies such as a first aid kit, a supply of water, a tow strap and a cell or satellite phone with you any time an off-road excursion is planned.

Terrain Management System (TMS)

Your vehicle is equipped with a Terrain Management System that allows the driver to enhance the off-road performance of the vehicle, by selecting the mode best suited to the terrain and driving conditions. Each mode changes a number of the vehicle parameters within the engine, transmission, traction control and all-wheel drive systems.

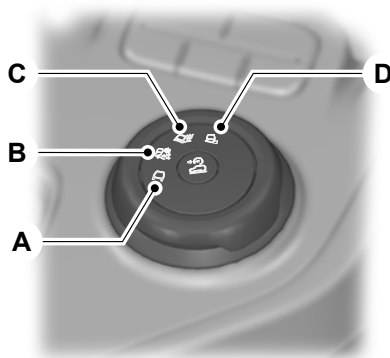

E206127

- A **Normal mode** - This mode is for on-road conditions and should be used on surfaces which are similar to hard road surfaces, or once the need for any of the off-road modes has passed.
- B **Mud/Snow** – This mode should be used where a firm surface is covered with loose or slippery material. This includes gravel, shallow mud, wet grass or snow covered road.
- C **Sand** - This mode should be used for crossing deep sand or deep sticky mud.
- D **Rock** - This mode gives low speed controllability for crawling over rocks. Low range must be selected before this mode is activated. See **Using All-Wheel Drive** (page 129).

Driving Hints

High and Low Range Usage

	Normal	Mud/ Snow	Sand	Rock
High Range (H)	Yes	Yes	Yes	No
Low Range (L)	Yes	-	-	Yes

Low range can be selected by pressing the 4X4 LOW switch in the centre console.

Note: *If an entry condition for any mode is not met, the information display screen will display the appropriate messages to guide the driver through the proper operating procedures.*

Note: *Operating the vehicle in any of the off-road modes does not guarantee that the vehicle will not become stuck in sand, snow or mud or other debris. It is the driver's responsibility to assess off-road situations and determine if the terrain is passable.*

Off-Road Driving Aids

- ELD (electronic locking differential)
See **Electronic Locking Differential** (page 127).

Note: *The locking and unlocking speeds may be different in different TMS modes.*

- HDC (hill descent control)

Off-road Screen

The real-time status of your vehicles off-road systems can be continuously monitored using the first off-road screen found in the information displays screen. For more information, See **General Information** (page 67).

Basic Off-road Driving Techniques

- Grip the steering wheel with your thumbs on the outside of the rim. This will reduce the risk of injury due to abrupt steering wheel motions that occur when negotiating rough terrain. Do not grip the steering wheel with your thumbs inside the rim.
- Throttle, brake and steering inputs should be made in a smooth and controlled manner. Sudden inputs to the controls can cause loss of traction or upset the vehicle, especially while on sloped terrain or while crossing obstacles such as rocks or logs.
- Look ahead on your route noting upcoming obstacles, surface texture or color changes or any other factors which may indicate a change in available traction, and adjust the vehicle speed and route accordingly. During pre-run, mark obstacles with GPS markers to make sure appropriate speeds are used to avoid potential vehicle damage.
- When driving off-road, if the front or rear suspension is bottoming-out and/or excessive contact with the skid-plates is encountered, reduce vehicle speed to avoid potential damage to the vehicle.
- When running with other vehicles, it is recommended that communication is used and the lead vehicle notify other vehicles of obstacles that could cause potential vehicle damage.
- Always keep available ground clearance in mind and pick a route that minimizes the risk of catching the underside of the vehicle on an obstacle.

Driving Hints

- When negotiating low speed obstacles, applying light brake pressure in conjunction with the throttle will help prevent the vehicle from jerking and will allow you to negotiate the obstacle in a more controlled manner. Using 4x4 Low will also help with this.
- Use and equip your vehicle with supplemental safety equipment as discussed later in this chapter.
- Please consult your local off-road group for other helpful tips.
- off road driving requires a high degree of concentration. Even if your local law does not prohibit alcohol use while driving off-road, Ford strongly recommends against drinking if you plan to off-road.

Driving in Mud

- Deep mud should be approached with caution especially if you are driving in an unfamiliar area.
- If possible, test the depth of a mud hole before entering with the vehicle.
- Keep in mind that obstacles and deep ruts may be hidden beneath the surface of the mud.
- Proceed in a steady, controlled manner through deep mud while maintaining momentum.
- If momentum is lost and you feel the vehicle becoming stuck, turning the steering wheel back and forth (sawing the wheel) a quarter turn in each direction may give the vehicle the traction needed to clear the muddy area.
- In higher speed areas with shallow mud, directional control will be reduced in the muddy area much like on snow or ice. When approaching such an area, be sure to slow to a speed which allows you to maneuver as required by the conditions.

Driving in Sand

WARNING



Tires must be returned to normal recommended tire pressures before driving on pavement or hard surfaces. Failure to properly maintain your tire pressure could increase the risk of tire failure, loss of control, vehicle rollover and personal injury.

Soft sand and dunes present a very unique driving challenge. Before going on such a drive, some research is advised regarding proven techniques and pitfalls inherent in driving in deep sand.

Some general points to consider:

- It is very difficult and in many cases impossible to navigate deep sand with tire pressures which are appropriate for on-road driving. If you decide to air down your tires, be advised that the tire pressure monitoring light will illuminate. The tires must be returned to normal recommended tire pressures before driving on pavement or hard surfaces.
- Lower tire pressures are more likely to cause a debanding of the tire during cornering. Avoid sharp or abrupt turns when you have extremely low tire pressures.
- To help prevent becoming stuck in deep sand, avoid spinning the tires or making abrupt maneuvers. Proceed in a controlled manner while maintaining vehicle momentum.
- Avoid stopping or parking on inclines as this makes it more difficult to resume driving while in sand.

Driving Hints

Driving in Deep Snow

- Maintain vehicle momentum.
- Apply the throttle very gently to avoid spinning the tires. Spinning the tires will potentially dig the vehicle deeper into the snow.
- Drive in a controlled manner, avoiding aggressive steering wheel movements, and keep braking to a minimum.
- Extremely deep snow may cause the undercarriage of the vehicle become to become stuck. Test the depth of the snow before trying to drive through or over it.

Crossing Obstacles

- Review the path ahead before attempting to cross any obstacle. It is best if the obstacle is reviewed from outside the vehicle so that there is a good understanding of terrain condition both in, front of, and behind the obstacle.
- Approach obstacles slowly and slowly inch the vehicle over.
- If a large obstacle such as a rock cannot be avoided, choose a path that places the rock directly under the tire rather than the undercarriage of the vehicle. This will help prevent damage to the vehicle.
- Ditches and washouts should be crossed at a 45 degree angle, allowing each wheel to independently cross the obstacle.

Hill Climbing

WARNING



Extreme care should be used when steering the vehicle in reverse down a slope so as not to cause the vehicle to swerve out of control.

- Always attempt to climb a steep hill along the fall line of the slope and not diagonally.
- If the vehicle is unable to make it up the hill, DO NOT attempt to turn back down the slope. Place the vehicle in low range and slowly back down in reverse.
- When descending a steep slope, select low gear and engage hill descent control. Use the throttle and brake pedals to control your descent speed as described earlier in this section using hill descent control. Note that hill descent control is functional in reverse and should be used in this situation.

Water Wading

See **Driving Through Water** (page 182).

After Off-Road Driving

It is important to complete a full vehicle inspection after off-road driving. Some items to check include:

- Make sure that tires are inflated to proper tire pressure as indicated on the tire placard.
- Check the wheels and undercarriage for built up mud or debris which can cause vehicle vibration.
- Make sure that the grille and radiator are clear of any obstructions that may affect cooling.
- Make sure that the brakes are in proper working order and are free of any mud, stones and debris, which can become trapped around the brake rotor, backing plate and caliper.
- Check that the air filter is clean and dry.
- Inspect for torn or punctured boots on ball joints, half shafts and steering gears.
- Inspect the exhaust system for damage or looseness.

Driving Hints

- Inspect the undercarriage fasteners. If any are loose or damaged, tighten or replace ensuring that the proper torque specification is used.
- Inspect the tires for any cuts in the tread or sidewall area. Also inspect the sidewall for any bulge indicating damage to the tire.
- Inspect the wheels for dents, cracks, or other damage.

COLD WEATHER PRECAUTIONS

The functional operation of some components and systems can be affected at temperatures below -25°C.

DRIVING THROUGH WATER

WARNINGS



Drive through water in an emergency only and not as part of normal driving.



Engine damage can occur if water enters the air filter.

In an emergency, you can drive your vehicle through water to a maximum depth as shown and at a maximum speed of 7 km/h. You must take extra care when driving through flowing water.

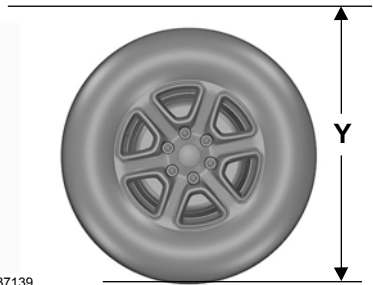

E137139

Y 800mm (31.5 inches)

When driving in water, maintain a low speed and do not stop your vehicle. After driving through water and as soon as it is safe to do so:

- Depress the brake pedal lightly to check that the brakes are functioning correctly.
- Check that the horn works.
- Check that your vehicle's lamps are fully operational.
- Check the power assistance of the steering system.

FLOOR MATS

WARNINGS



Always use floor mats that are designed to fit the foot well of your vehicle. Only use floor mats that leave the pedal area unobstructed. Only use floor mats that are firmly secured to retention posts so that they cannot slip out of position and interfere with the pedals or impair safe operation of your vehicle in other ways.





Pedals that cannot move freely can cause loss of vehicle control and increase the risk of serious personal injury.

Driving Hints

WARNINGS

 Always make sure that the floor mats are properly attached to the retention posts in the carpet that are supplied with your vehicle. Floor mats must be properly secured to both retention posts to make sure mats do not shift out of position.

 Never place floor mats or any other covering in the vehicle foot well that cannot be properly secured to prevent them from moving and interfering with the pedals or the ability to control the vehicle.

 Never place floor mats or any other covering on top of already installed floor mats. Floor mats should always rest on top of vehicle carpeting surface and not another floor mat or other covering. Additional floor mats or any other covering will reduce the pedal clearance and potentially interfere with pedal operation.

 Check attachment of floor mats on a regular basis. Always properly reinstall and secure floor mats that have been removed for cleaning or replacement.

 Always make sure that objects cannot fall into the driver foot well while the vehicle is moving. Objects that are loose can become trapped under the pedals causing a loss of vehicle control.

 Failure to properly follow floor mat installation or attachment instructions can potentially cause interference with pedal operation causing a loss of vehicle control.



E142666

To install floor mats, position the floor mat so that the eyelet is over the retention post and press down to lock in.

To remove the floor mat, reverse the installation procedure.

Roadside Emergencies

HAZARD WARNING FLASHERS



The hazard warning button is located on the instrument panel.

Use it when your vehicle is creating a safety hazard for other motorists.

Press the button to turn on the hazard warning function, and the front and rear direction indicators will flash.

Press the button again to turn them off.

Note: *If used when the engine is not running, the battery will lose charge. There may be insufficient power to restart your engine.*

Note: *Depending on applicable laws and regulations in the country for which your vehicle was originally built, the hazard warning flashers may flash if you brake heavily.*

JUMP STARTING THE VEHICLE

WARNINGS



Do not use fuel lines, engine rocker covers or the intake manifold as grounding points.



Connect batteries with only the same nominal voltage.



Use only adequately sized cables with insulated clamps.

Note: *Do not disconnect the battery of the disabled vehicle as this could damage the vehicle electrical system.*

Connecting the Jumper Cables

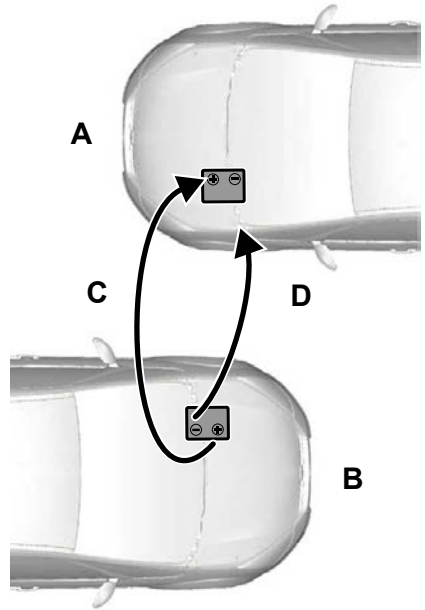

E102925

- A Flat battery vehicle.
- B Booster battery vehicle.
- C Positive connection cable.
- D Negative connection cable.

WARNING



Do not let the vehicles come into contact when using booster cables.

1. Position the vehicles in a suitable arrangement to connect the booster cables.
2. Switch off the engine and any electrical equipment.

Roadside Emergencies

3. Connect the positive (+) terminal of vehicle B with the positive (+) terminal of vehicle A (cable C).

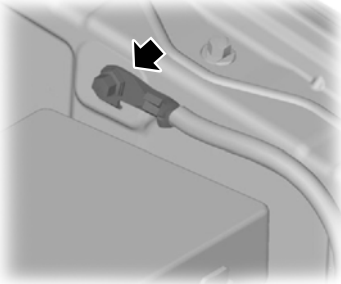

E205764

WARNINGS



Do not connect directly to the negative (-) terminal of the flat battery.



Make sure that the cables are clear of any moving parts and fuel delivery system parts.

4. Connect the negative (-) terminal of vehicle B to the ground connection of vehicle A (cable D).

To Start the Engine

WARNING



Do not switch the headlamps on when disconnecting the cables. The peak voltage could blow the bulbs.

1. Run the engine of vehicle B at a moderately high speed.
2. Start the engine of vehicle A.
3. Run both vehicles for a minimum of three minutes before disconnecting the cables.

Disconnect the cables in the reverse order.

POST-CRASH ALERT SYSTEM

The system flashes the direction indicators and sounds the horn (intermittently) in the event of a serious impact that deploys an airbag (front, side, side curtain or safety canopy) or the seatbelt pretensioners.

The horn and indicators will turn off when:

- You press the hazard control button.
- You press the panic button on the remote entry transmitter.
- Your vehicle runs out of power.

Note: *The horn will not sound after a serious impact if the emergency assistance is triggered by SYNC.*

Roadside Emergencies

TRANSPORTING THE VEHICLE

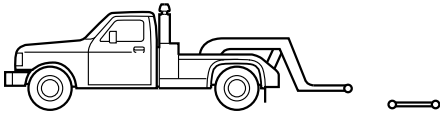

Towing an all-wheel drive vehicle requires that all wheels be off the ground, such as using a wheel lift and dollies or flatbed equipment. This prevents damage to the transmission, all-wheel drive system and vehicle.

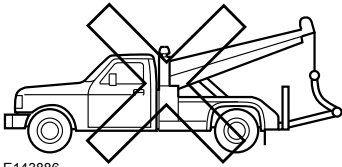
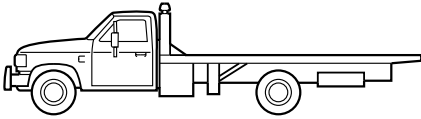

E143886

If you need to have your vehicle towed, contact a professional towing service or, if you are a member of a roadside assistance program, your roadside assistance service provider.

We recommend the use of a wheel lift and dollies or flatbed equipment to tow your vehicle. Do not tow with a slingbelt. Ford Motor Company has not approved a slingbelt towing procedure. Vehicle damage may occur if towed incorrectly, or by any other means.

Ford Motor Company produces a towing manual for all authorized tow truck operators. Have your tow truck operator refer to this manual for proper hook-up and towing procedures for your vehicle.

Fuses

FUSE BOX LOCATIONS

Fuse Box Locations

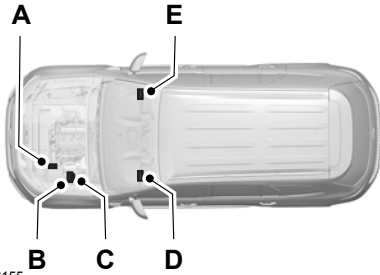

E206155

- A Pre-fuse box.
- B Engine compartment fuse box (Power Distribution Box - PDB).
- C High current fuse box (below the PDB).
- D Passenger compartment fuse box.¹
- E Passenger compartment fuse box.²

¹ - Left Hand Drive.

² - Right Hand Drive.

Pre-Fuse Box

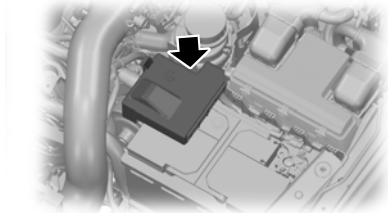

E206156

Your vehicle has a pre-fuse box located in the engine compartment attached to the positive battery post. This box contains several high current fuses. If replacement of these high current fuses is required, see an authorized dealer.

Engine Compartment Fuse Box (Power Distribution Box - PDB)

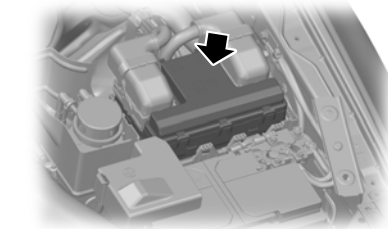

E206157

WARNINGS



Always disconnect the battery before servicing high current fuses.



To reduce risk of electrical shock, always replace the cover to the engine compartment fuse box before reconnecting the battery or refilling fluid reservoirs.

Fuses

The engine compartment fuse box has high-current fuses that protect your vehicle's main electrical systems from overloads.

When you disconnect and reconnect the battery, you will need to reset some features. See **Changing the 12V Battery** (page 208).

Lift the release lever at the rear of the cover to remove it.

High Current Fuse Box

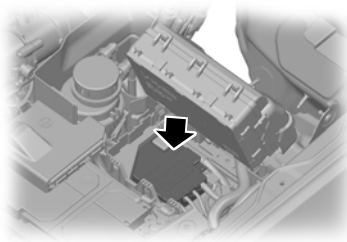

E206158

Your vehicle has a pre-fuse box located in the engine compartment below the engine compartment fuse box. This box contains several high current fuses. If replacement of these high current fuses is required, see an authorized dealer.

Passenger Compartment Fuse Box

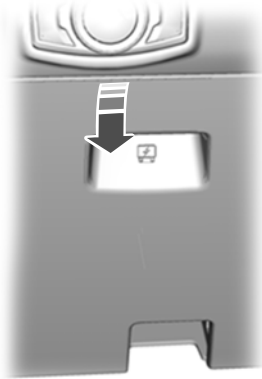



E206167

The fuse box is located behind the access cover on the outboard side of the steering column.

CHANGING A FUSE

WARNINGS

-  Do not modify the electrical system of your vehicle in any way. Have repairs to the electrical system and the replacement of relays and high current fuses carried out by an authorized dealer.
-  Switch the ignition and all electrical equipment off before attempting to change a fuse.
-  Always replace a fuse with one that has the specified amperage rating. Using a fuse with a higher amperage rating can cause severe wire damage and could start a fire.

Fuses

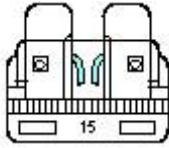

E142430

If electrical components in your vehicle are not working, a fuse may have blown. Check the appropriate fuses before replacing any electrical components.

FUSE SPECIFICATION CHART - 3.2L DURATORQ-TDCI (148KW/200PS) - PUMA

Engine Compartment Fuse Box

WARNINGS



Always disconnect the battery before servicing high-current fuses.

WARNINGS



To reduce risk of electrical shock, always replace the cover to the engine compartment fuse box before reconnecting the battery or refilling fluid reservoirs.

The engine compartment fuse box has high-current fuses that protect your vehicle's main electrical systems from overloads. When you disconnect and reconnect the battery, you will need to reset some features. See **Changing the 12V Battery** (page 208). Lift the release levers at the rear of the cover to remove it.

Fuses

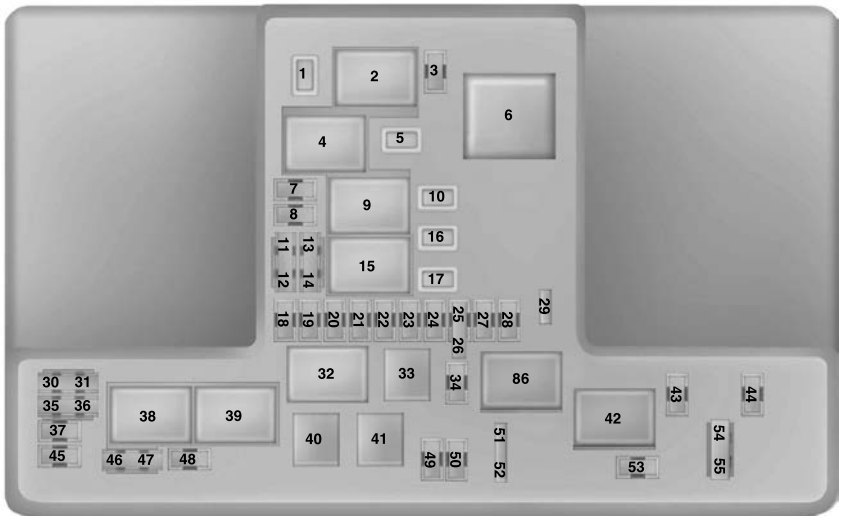

E190797

Fuse/Relay Number	Fuse Amp Rating	Protected Components
1	25 ³	Not used.
2	-	Starter motor solenoid relay.
3	15 ¹	Rear wiper, rain sensor.
4	-	Front blower motor relay.
5	20 ³	Power point 3 (console rear).
6	-	Headlamp low beam relay (high intensity discharge).
7	20 ¹	Powertrain control module.
8	20 ¹	Power train control module - volumetric control valve, EGR cooler bypass, TMAF.

Fuses

Fuse/Relay Number	Fuse Amp Rating	Protected Components
9	-	Powertrain control module relay.
10	20 ³	Power point 1 / cigar lighter.
11	15 ²	Powertrain control module - NOX sensor (if fitted).
12	15 ²	Powertrain control module - fan drive, glow plug control module.
13	15 ²	Not used.
14	15 ²	Not used.
15	-	Run/start relay.
16	20 ³	Power point 2 / cigar lighter .
17	20 ³	Power point 4 - 3rd row power point .
18	10 ¹	Not used.
19	10 ¹	Electric power assisted steering.
20	10 ¹	Headlamp switch, headlamp levelling motor.
21	15 ¹	Transfer case control module - terrain management switch.
22	10 ¹	Air conditioning compressor.
23	15 ¹	Parking aid rear view camera, blind spot monitoring module, adaptive speed control radar and heads up display (if fitted).
24	5 ¹	Exhaust emissions - rear dosing control module (if fitted).
25	10 ²	Anti-lock brake system.
26	10 ²	Mirror adjust switch.
27	5 ¹	PTC Heater (if fitted).
28	10 ¹	Powertrain control module.

Fuses

Fuse/Relay Number	Fuse Amp Rating	Protected Components
29	10 ¹	Rear window washer pump.
30	-	Not used.
31	-	Not used.
32	-	Not used.
33	-	Air conditioning clutch relay.
34	-	Not used.
35	15 ¹	Transmission control module.
36	-	Not used.
37	10 ¹	Heated exterior mirror.
38	-	Not used.
39	-	Not used.
40	-	Fuel pump relay.
41	-	Horn relay.
42	-	Seat third row power fold relay.
43	15 ¹	Exhaust emissions - rear dosing control module (if fitted).
44	25 ¹	Headlamp washer pump.
45	-	Not used.
46	10 ²	Not used.
47	10 ²	Brake pedal switch.
48	20 ¹	Horn.
49	5 ¹	Not used.
50	15 ¹	Exhaust emissions - rear dosing control module (if fitted).
51	-	Not used.

Fuses

Fuse/Relay Number	Fuse Amp Rating	Protected Components
52	-	Not used.
53	-	Not used.
54	10 ²	Exhaust emissions - rear dosing control module (if fitted).
55	10 ²	Exhaust emissions - rear dosing control module (if fitted).
86	-	Rear blower motor relay.

¹Micro fuse.

²Dual micro fuse.

³M-type fuse.

Power Distribution Box - Bottom

There are fuses located on the bottom of the fuse box. To access the bottom of the fuse box, do the following:

1. Release the two latches, located on both sides of the fuse box.
2. Raise the rear side of the fuse box from the cradle.

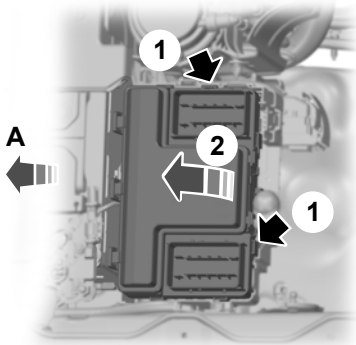

E206171

- A Towards the front side of the vehicle.

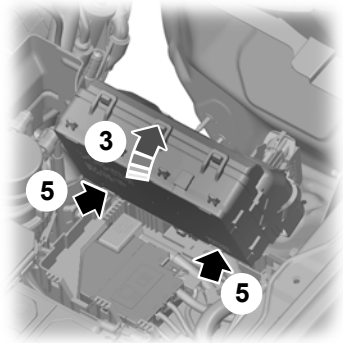

E206174

3. Move the fuse box toward the rear side of the engine compartment and rotate as shown in the graphics.

Fuses

4. Pivot the rear side of the fuse box to access the bottom side.
5. Release the two latches to open the fuse cover.

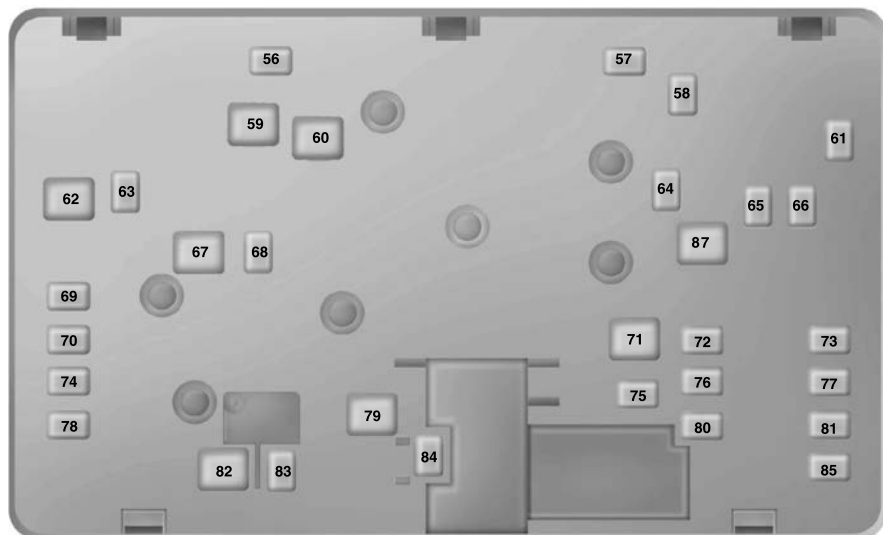

E190798

Fuse/Relay Number	Fuse Amp Rating	Protected Components
56	30 ³	Fuel pump control module.
57	-	Not used.
58	-	Not used.
59	-	Not used.
60	-	Not used.
61	-	Not used.
62	50 ⁴	Body control module 1 (lighting).
63	-	Not used.

Fuses

Fuse/Relay Number	Fuse Amp Rating	Protected Components
64	20 ³	Trailer auxilliary.
65	20 ³	Heated front seats.
66	-	Not used.
67	50 ⁴	Body control module 2 (lighting).
68	40 ³	Rear window defroster.
69	30 ³	Antilock brake system valves.
70	20 ³	Passenger power seat.
71	-	Not used.
72	30 ³	Third row power fold seat.
73	-	Not used.
74	20 ³	Driver power seat.
75	25 ³	Rear blower motor.
76	20 ³	Left-hand low beam high-intensity discharge head-lamps (if fitted).
77	25 ³	AWD module.
78	25 ³	AWD module.
79	40 ⁴	Blower motor.
80	20 ³	Right-hand low beam high-intensity discharge head-lamps (if fitted).
81	40 ³	Inverter.
82	60 ⁴	Anti-lock brake system pump.
83	25 ³	Windshield wiper motor.

Fuses

Fuse/Relay Number	Fuse Amp Rating	Protected Components
84	30 ³	Starter motor solenoid.
85	30 ³	Power lift gate module.
87	40 ⁴	Trailer module.

¹Micro fuse.

²Dual micro fuse.

³M-type fuse.

⁴LPJ-type fuse.

Battery Mounted Fuse Link

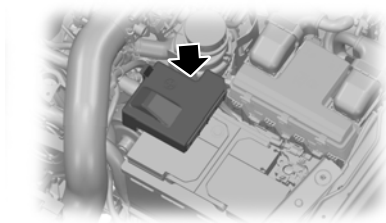

E206156

Fuse	Fuse Amp Rating	Protected Components
1	225	Alternator.
2	125	Electronic power assist steering.

Fuses

High Current Fuse Box

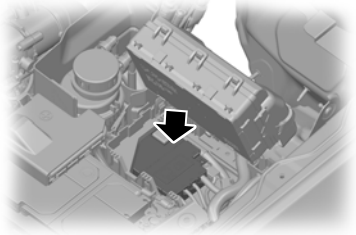

E206158

Fuse	Fuse Amp Rating	Protected Components
1	60	Glow plug module.
2	125	Body control module.
3	50	Body control module.
4	-	Busbar through to power distribution box.
5	100	PTC Heater (if fitted).

Passenger Compartment Fuse Box

The fuse box is located below and outboard of the steering column behind the access cover.

Fuses

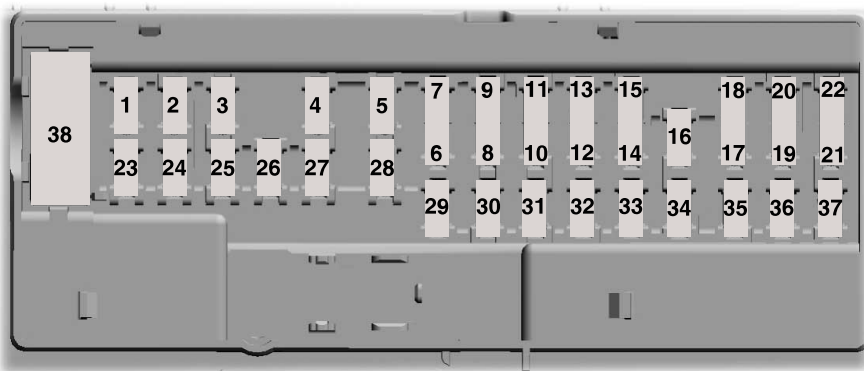

E145984

Fuse	Fuse Amp Rating	Protected Components
1	10 ¹	Demand lamp / battery saver - overhead console, automatic transmission gear shifter, glove box lamp, sun visor, grab handle, Map lamps.
2	7.5 ¹	Not used (spare).
3	20 ¹	Driver door latch /fuel flap unlock relay, Door double/aux lock relay.
4	5 ¹	Not used (spare).
5	20 ¹	Subwoofer amplifier.
6	10 ²	Not used (spare).
7	10 ²	Not used (spare).
8	10 ²	Security horn.
9	10 ²	Not used (spare).
10	5 ²	Power liftgate module.
11	5 ²	Interior motion sensor.

Fuses

Fuse	Fuse Amp Rating	Protected Components
12	7.5 ²	Electronic control panel, climate control module, rear auxiliary module.
13	7.5 ²	Instrument cluster, steering column control module, smart data link connector.
14	10 ²	Not used (spare).
15	10 ²	Gateway module/smart data link connector - OBD II (RHD).
16	15 ¹	Child lock.
17	5 ²	Battery backed sounder.
18	5 ²	Ignition switch.
19	7.5 ²	Not used (spare).
20	7.5 ²	Headlamp control module (if fitted).
21	5 ²	Humidity and in car temperature sensor.
22	5 ²	Not used (spare).
23	10 ¹	Inverter, door lock switch, moon roof, driver door window switch (one touch up/down all doors).
24	20 ¹	Central locking system.
25	30 ¹	Driver door control module (power window one touch up/down all doors) Driver door power window switch memory (with one touch up/down driver only)
26	30 ¹	Passenger door control module (power window - one touch up/down).
27	30 ¹	Moonroof.
28	20 ¹	Not used (spare).
29	30 ¹	Left rear door control module (power window - one touch up/down).
30	30 ¹	Right rear door control module (power window - one touch up/down).

Fuses

Fuse	Fuse Amp Rating	Protected Components
31	15 ¹	Not used (spare).
32	10 ¹	Radio transceiver module, SYNC, global positioning system module, multi function display, door entry remote.
33	20 ¹	Audio unit.
34	30 ¹	Run/start relay.
35	5 ¹	Restraints control module.
36	15 ¹	Interior rear view mirror electrochromatic.
37	15 ¹	Not used (spare).
38	30 ³	Power windows (without door control module - with one touch up/down driver only).

¹Micro fuse.

²Dual micro fuse.

³PTC fuse

Maintenance

GENERAL INFORMATION

Have your vehicle serviced regularly to help maintain its roadworthiness and resale value. There is a large network of Ford authorized repairers that are there to help you with their professional servicing expertise. Authorized repairers are best qualified to service your vehicle properly and expertly, with a wide range of highly specialized tools.

In addition to regular servicing, we recommend that you carry out the following checks.

WARNINGS



Switch the ignition off before touching or attempting adjustment of any kind.



Do not touch the electronic ignition system parts after you have switched the ignition on or when the engine is running. The system operates at high voltage.



Keep your hands and clothing clear of the engine cooling fan. Under certain conditions, the fan may continue to run for several minutes after you have switched the engine off.



Make sure that you fit filler caps securely after carrying out maintenance checks.

Daily Checks

- Exterior lamps.
- Interior lamps.
- Warning lamps and indicators.

Check When Refueling

- Engine oil level. See **Engine Oil Check** (page 205).
- Brake fluid level. See **Brake and Clutch Fluid Check** (page 207).

- Washer fluid level. See **Washer Fluid Check** (page 207).
- Tire pressures (when cold). See **Technical Specifications** (page 233).
- Tire condition. See **Wheels and Tires** (page 219).

Note: Make sure that your vehicle is on level ground.

Monthly Checks

- Engine coolant level (engine cold). See **Engine Coolant Check** (page 205).
- Pipes, hoses and reservoirs for leaks.
- Air conditioning operation.
- Parking brake operation.
- Horn operation.
- Tightness of lug nuts. See **Technical Specifications** (page 233).

OPENING AND CLOSING THE HOOD

Opening the Hood



E206129

Maintenance

1. Pull the hood release lever. See **At a Glance** (page 9).

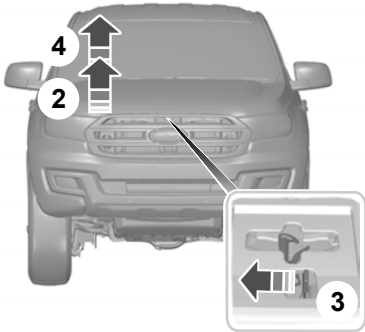

E207690

2. Slightly lift the hood.
3. Move the catch to the left for vehicles with left hand drive. Move the catch to the right for vehicle with right hand drive.
4. Open the hood.

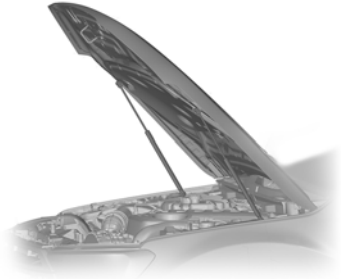

E201861

5. The hood strut automatically supports the hood.

Closing the Hood

1. Lower the hood and allow it to drop under its own weight for the last 20–30 cm.
2. If necessary, apply a downward force on the leading edge of the hood prior to engage with the latch, to latch the hood fully.

Note: *Make sure that the hood is correctly closed.*

Maintenance

UNDER HOOD OVERVIEW - 3.2L DURATORQ-TDCI (143KW/ 194PS) - PUMA

LHD

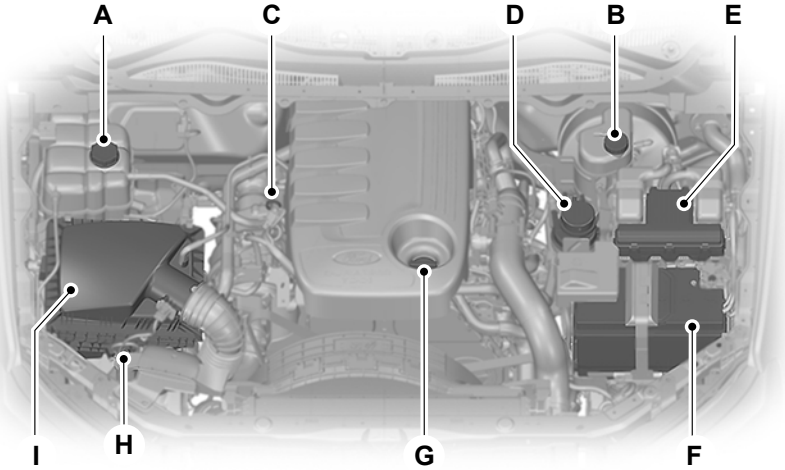

E200935

Maintenance

RHD

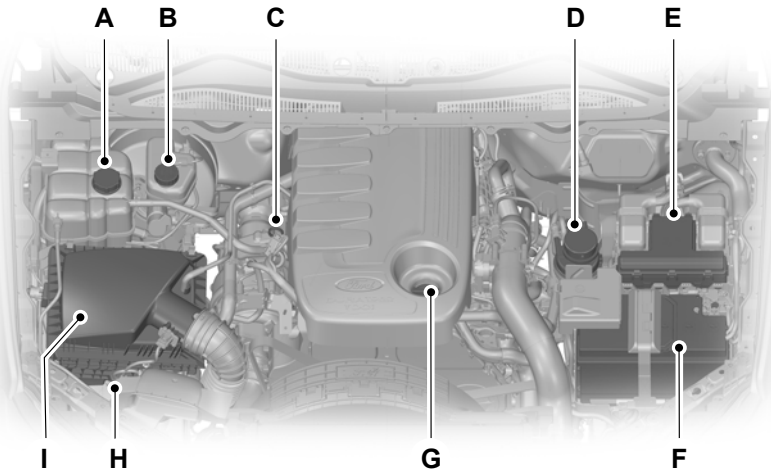

E200848

- A Engine coolant reservoir cap. See **Engine Coolant Check** (page 205).
- B Brake and clutch fluid reservoir cap. See **Brake and Clutch Fluid Check** (page 207).
- C Engine oil dipstick. See **Engine Oil Dipstick** (page 205).
- D Fuel filter water drain. See **Draining the Fuel Filter Water Trap** (page 207).
- E Engine compartment fuse box. See **Fuses** (page 187).
- F Battery. See **Roadside Emergencies** (page 184).
- G Engine oil filler cap. See **Engine Oil Check** (page 205).
- H Washer fluid reservoir cap. See **Washer Fluid Check** (page 207).
- I Air Cleaner.

Maintenance

ENGINE OIL DIPSTICK

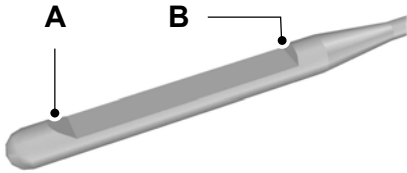

E71362

- A MIN
- B MAX

ENGINE OIL CHECK

1. Make sure that your vehicle is on level ground.
2. Switch off the engine and wait 10 minutes for the oil to drain into the oil pan.
3. Remove the dipstick and wipe it with a clean, lint free cloth. Replace the dipstick and remove it again to check the oil level.

If the oil level is at the minimum mark, add oil immediately.

Note: Check the oil level before starting the engine.



Note: Make sure that the oil level is between the minimum and the maximum marks.

Note: Do not use oil additives or other engine treatments. Under certain conditions, they may damage the engine.

Note: The oil consumption of new engines reaches its normal level after approximately 5,000 km.

Adding Oil

WARNINGS

-  Only add oil when the engine is cold. If the engine is hot, wait 10 minutes for the engine to cool down. Failure to take care may result in personal injury.
-  Do not remove the filler cap when the engine is running. Failure to take care may result in personal injury.



1. Remove the filler cap.
2. Add oil that meets Ford specifications.
3. Replace the filler cap. Turn it until you feel a strong resistance.

Note: Do not add oil further than the maximum mark. Oil levels above the maximum mark may cause engine damage.

Note: Soak up any spillage with an absorbent cloth immediately.

ENGINE COOLANT CHECK

WARNINGS

-  Do not dispose of engine coolant in the household refuse or the public sewage system. Use an authorized waste disposal facility.
-  Do not put engine coolant in the windshield washer fluid container. If sprayed on the windshield, engine coolant could make it difficult to see through the windshield.

Maintenance

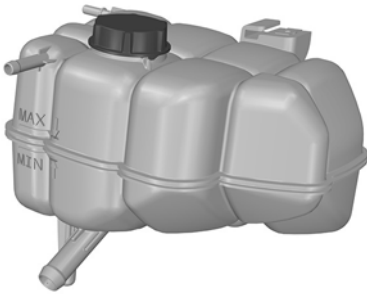

E206128

Make sure that the coolant level is between the **MIN** and **MAX** marks on the coolant reservoir. If the coolant level is at or below the minimum mark, add coolant immediately.

Maintain coolant concentration within 48% to 50%, which equates to a freeze point between -29°C and -34°C.

Note: Make sure that your vehicle is on level ground.

Note: Coolant expands when it is hot. The level may expand beyond the **MAX** mark.

Note: Do not use Stop Leak Pellets, cooling system sealants or additives as they can cause damage to the engine cooling or heating systems.

Adding Engine Coolant

WARNINGS

 Do not remove the coolant reservoir cap while the engine is running or hot.

 Only add coolant when the engine is cold. If the engine is hot, wait 10 minutes for the engine to cool down.

WARNINGS

 Do not allow the coolant to touch your skin or eyes. If this happens, rinse the affected areas immediately with plenty of water and contact your physician.

 Undiluted coolant is flammable and may ignite if spilled on a hot exhaust.

 Do not mix different colors or types of coolant in your vehicle.

Ford Motor Company does not recommend the use of recycled engine coolant since a Ford-approved recycling process is not yet available.

Note: Add a 50/50 mixture of antifreeze and water or prediluted engine coolant that meets the correct specification.

Note: Use coolants which meet the specifications or requirements defined. Use of other coolants may lead to damage which is not covered by your vehicle's Warranty.

To top up the coolant level do the following:

1. Unscrew the cap **SLOWLY**. Any pressure will escape as you unscrew the cap.
2. Add engine coolant to the MAX mark, do not overfill.
3. Refit filler cap. Turn it clockwise until you feel a strong click.

Note: In case of emergency, you can add water without engine coolant in order to reach a vehicle service location.

Note: Prolonged use of an incorrect dilution of engine coolant can cause engine damage, such as corrosion, overheating or freezing.

Note: The cooling system filler cap should be inspected and cleaned regularly. The cap should be replaced if there is any evidence of deterioration of the sealing.

Maintenance

BRAKE AND CLUTCH FLUID CHECK

WARNINGS



Use of any fluid other than the recommended brake fluid may reduce brake efficiency and not meet Ford's performance standards.



Do not allow the fluid to touch your skin or eyes. If this happens, rinse the affected areas immediately with plenty of water and contact your doctor.



Clean the filler cap before removing. Use only fluid that meets Ford specifications and from a sealed container.

Note: *Keep brake fluid clean and dry. Contamination with dirt, water, petroleum products or other materials may result in brake system damage and possible failure.*

Note: *The brake and the clutch systems are supplied from the same reservoir.*

Note: *Make sure that your vehicle is on level ground.*

The fluid level will drop slowly as the brakes wear, and will rise when the brake components are replaced.

Fluid levels between the MIN and MAX lines are within the normal operating range; there is no need to add fluid.

If the fluid levels are outside of the normal operating range, the performance of the system could be compromised; seek service from your authorized dealer immediately.

Top up with fluid that meets the Ford specification.

WASHER FLUID CHECK

Note: *The reservoir supplies the front and rear washer systems.*

When adding fluid, use a mixture of washer fluid and water to help prevent freezing in cold weather and improve the cleaning capability. We recommend that you use only high quality washer fluid.

For information on fluid dilution, refer to the product instructions.

DRAINING THE FUEL FILTER WATER TRAP

WARNING



Do not dispose of fuel in the household refuse or the public sewage system. Use an authorized waste disposal facility.

Note: *Only add fuel that meets the Ford specification. See **Fuel Quality** (page 116).*

Note: *The in-tank pump will turn off automatically after approximately 40 seconds.*

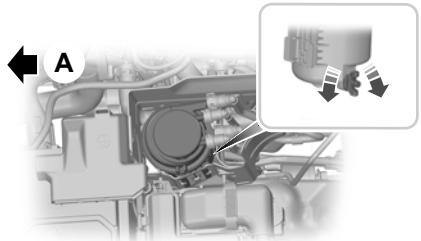

E208053

A Front of Vehicle.

For item location: See **Under Hood Overview** (page 203).

Maintenance

1. Switch the ignition off.
2. Attach a tube to the drain plug and place the end of the tube into a suitable container.
3. Loosen the drain plug approximately 1.5 turns.
4. Switch the ignition on to activate the in-tank pump.
5. Allow the water to drain.
6. Switch the ignition off.
7. Tighten the drain plug until you feel a strong resistance.
8. Remove the tube from the drain plug.
9. Start the engine.
10. Check for leaks.

Note: *The water-in-fuel indicator lamp will go out after approximately 2 seconds, with the engine running.*

CHANGING THE 12V BATTERY

WARNING



For vehicles with start-stop the battery requirement is different. You must replace the battery with one of exactly the same specification.

Note: *Where applicable you must reprogram the audio system using the keycode.*

The battery is located in the engine compartment. See **Maintenance** (page 201).

CHECKING THE WIPER BLADES



E222238

Run the tip of your fingers over the edge of the blade to check for roughness.

Clean the wiper blades with isopropyl alcohol or windscreen washer concentrate.

CHANGING THE WIPER BLADES

Changing the Windshield Wiper Blades

Note: *The windshield wiper blades are different in length. If you install wiper blades of the wrong length, the wiper blades can clash damaging the wiper system.*

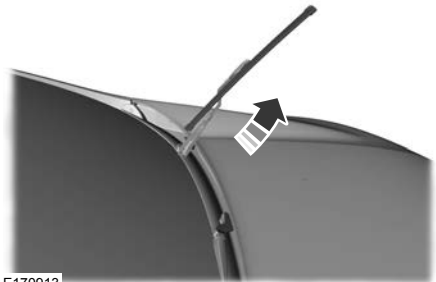

E170913

Maintenance

1. Manually move the wiper arms to the service position.

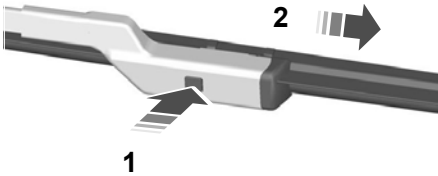

E72899

2. Press and hold the locking button.
3. Remove the wiper blade.
4. Install in the reverse order.

Note: Make sure that the wiper blade locks into place.

Changing the Rear Window Wiper Blade



E175222

Note: The rear wiper arm cannot be lifted up beyond 25–30°. This is to prevent damage during automatic car wash.

1. Move the wiper arms to the service position manually.

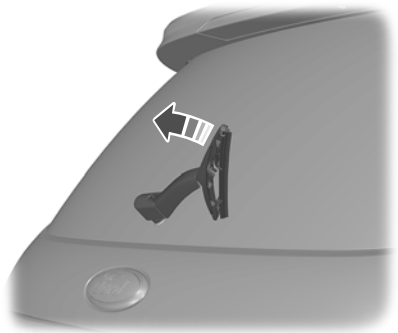

E206062

2. Tightly hold the blade assembly at the top and rotate it anti-clockwise till the blade assembly disengages from the wiper arm.

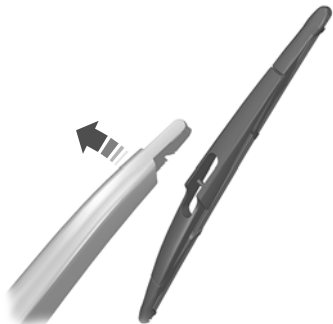

E206063

3. Align the new blade assembly with the wiper arm groove and clip them together.

Note: Make sure that the wiper blade locks into place.

Note: When the rear wiper blade requires replacement, the whole blade assembly has to be replaced.

Maintenance

REMOVING A HEADLAMP

Contact an authorized dealer.

CHANGING A BULB

Lamp Assembly Condensation

Exterior lamps are vented to accommodate normal changes in pressure. Condensation can be a natural by-product of this design. When moist air enters the lamp assembly through the vents, there is a possibility that condensation can occur when the temperature is cold. When normal condensation occurs, a thin film of mist can form on the interior of the lens. The thin mist eventually clears and exits through the vents during normal operation. Clearing time may take as long as 48 hours under dry weather conditions.

Examples of acceptable condensation are:

- Presence of thin mist (no streaks, drip marks or droplets).
- Fine mist covers less than 50% of the lens.

Examples of unacceptable moisture (usually caused by a lamp water leak) are:

- Water puddle inside the lamp.
- Large water droplets, drip marks or streaks present on the interior of the lens.

Take your vehicle to an authorized dealer for service if any of the above conditions of unacceptable moisture are present.

Replacing the Headlamp Bulbs

WARNING



Handle a halogen headlamp bulb carefully and keep out of children's reach. Grasp the bulb by only its plastic base and do not touch the glass. The oil from your hand could cause the bulb to break the next time the headlamps are operated.

Note: For replacement of HID type headlamp globes, see your authorized dealer.

Note: If the bulb is accidentally touched, it should be cleaned with rubbing alcohol before being used.

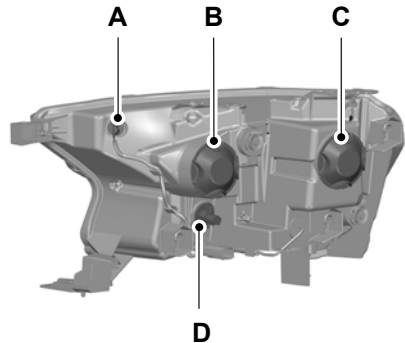

E205822

Headlamp assembly:

- A. Front parking lamp bulb.
- B. High beam headlamp bulb/ Daytime running lamp bulb.
- C. Low beam headlamp bulb.
- D. Direction indicator lamp bulb.

Maintenance

Replacing the High Beam Headlamp Bulb

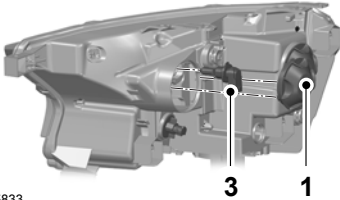

E205833

1. Remove the service cap.
2. Disconnect the electrical connector.
3. Remove the bulb from the headlamp assembly by turning it counterclockwise and pull it straight out.¹
4. Install the new bulb in reverse order.

Replacing the Low Beam Headlamp Bulb

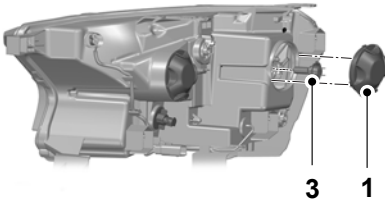

E205825

1. Remove the service cap.
2. Disconnect the electrical connector.
3. Remove the bulb from the headlamp assembly by turning it counterclockwise and pull it straight out.¹

4. Release the retainer spring and remove the bulb from the headlamp assembly by pulling it straight out.²

¹- Projector type headlamp assembly.

²- Reflector type headlamp assembly.

Replacing the Front Parking Bulb

1. Turn the bulb assembly counterclockwise and remove it from the headlamp assembly.
2. Remove the bulb by gently pulling it straight out of the socket.
3. Install the new bulb in reverse order.

Replacing the Direction Indicator Lamp Bulb

1. Turn the bulb assembly counterclockwise and remove it from the headlamp assembly.
2. Remove the bulb from the bulb socket by gently pushing it into the socket and turning it counterclockwise.
3. Install the new bulb in reverse order.

Side Repeater

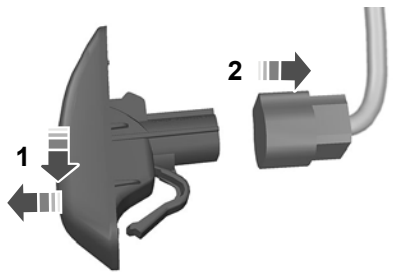

E133682

1. Slide the lens to the rear and remove it.
2. Disconnect the electrical connector.

Maintenance

Approach Lamp and Side Repeater

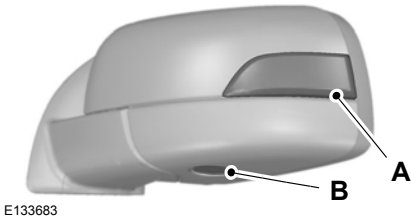

- A Side repeater.
- B Approach lamp.

Note: These lamps are not serviceable, contact an authorized dealer if it fails.

Front Fog Lamps

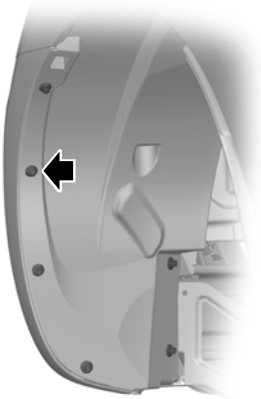

1. Remove the screws from the splash shield at the wheel well to gain access to the lamp assembly.
2. Disconnect the electrical connector.

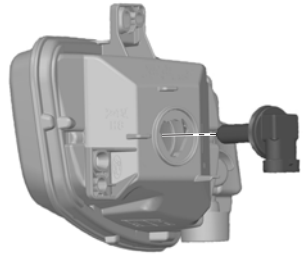

3. Turn the bulb holder counterclockwise and remove it.

Note: You cannot separate the fog lamp bulb from the bulb holder.

Replacing the Tail, Brake and Turn Signal Lamp Bulbs

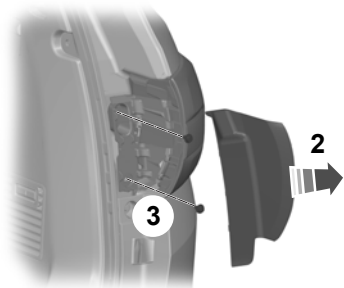

1. Make sure the headlamp control is in OFF position and open the liftgate.

Maintenance

2. Remove the tail lamp cover starting from the outboard edge using a flat tip screw driver.
3. Remove the two bolts from the lamp assembly.
4. Disconnect the electrical connector and gently pull out the lamp assembly.

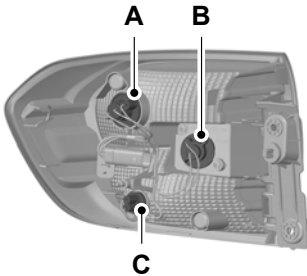

E206199

- A Rear turn signal.
- B Stop/Rear Position Lamp.
- C Rear Position lamp.

1. Remove the bulb socket from the lamp assembly by turning it counterclockwise.
2. Remove the bulb by:
 - Rear turn signal bulb - Gently pushing it into the socket and turning it counterclockwise.
 - Stop/Rear Position Lamp- Gently pushing it into the socket and turning it counterclockwise.
 - Rear position lamp- Gently pulling the bulb from the socket.

Install the new bulbs in reverse order from the steps above.

Note: If your vehicle is fitted with LED Stop/Rear Position Lamps these are not serviceable. Take your vehicle to an authorized dealer if they fail.

Replacing a Reverse Lamp Bulb

1. Open the liftgate.
2. Remove the lift gate inner grab handle cover using a standard flat tip screw driver.
3. Remove the handle by unscrewing the two screws using a standard cross tip screw driver.
4. Remove the lift gate inner trim panel to access the reverse lamp
5. Remove the bulb socket from the lamp assembly by turning it counterclockwise.
6. Remove the bulb by gently pulling it from the socket.

Install the new bulb in reverse order.

Replacing the Rear Fog Lamp Bulb



E206200

1. Remove the bulb socket from the lamp assembly by turning it counterclockwise.
2. Remove the bulb by gently pulling it from the socket.

Install the new bulbs in reverse order from the steps above.

Maintenance

Replacing the License Plate Lamp Bulb

Type 2

Type 1

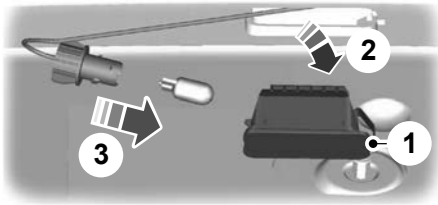

E72789

1. Carefully release the spring clip.
2. Remove the lamp.
3. Remove the bulb.

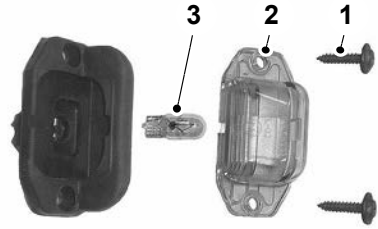

E133687

1. Remove the screws.
2. Remove the lamp lens.
3. Remove the bulb.

BULB SPECIFICATION CHART

Bulb	Specification	Power (Watts)
Headlamp low beam.*	H7	55
Headlamp low beam.**	H11	55
Headlamp high beam.*	H15	55
Headlamp high beam.**	HB3	60
Daytime running lamps.	H15	15
Front position lamp.	W5W	5
Front fog lamp.	H8	35
Front direction indicator.	P21W	21
Side direction indicator.	1	-
Rear direction indicator.	PY21W	21
Rear position lamp.	W5W	5
Rear position/Stop lamp	P21/5W	21/5

Maintenance

Bulb	Specification	Power (Watts)
Central high mounted brake lamp.	LED	
Reversing lamp.	W16W	16
Rear fog lamp.	P21W	21
License plate lamp.	W5W	5

* Reflector type.

** Projector type.

* With Daytime running lamps.

** Without Daytime running lamps.

¹ Bulb replacement is not possible as the bulb is an integral part of the unit. The side direction indicator lamp unit has to be replaced.

Maintenance

CHANGING THE ENGINE AIR FILTER

WARNING



To reduce the risk of vehicle damage and personal burn injuries, do not start your engine with the air cleaner removed and do not remove it while the engine is running.

When changing the air filter element, use only the air filter element listed.

When servicing the air cleaner, it is important that no foreign material enter the air induction system. The engine and turbocharger are susceptible to damage from even small particles.

Change the air filter element at the proper intervals.

Note: Failure to use the correct air filter element may result in severe engine damage. Resulting component damage may not be covered by the vehicle Warranty.

2. Carefully lift the air filter housing cover. Take care to avoid other surrounding components while lifting.
3. Remove the air filter element from the air filter housing.
4. Wipe any dirt or debris from the air filter housing and cover to make sure no dirt gets in the engine and that you have a good seal.
5. Install a new air filter element. Be careful not to crimp the filter element edges between the air filter housing and cover.
6. Install the air filter housing cover.
7. Engage the clamps to secure the air filter housing cover to the air filter housing.

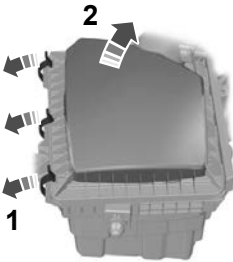

E197418

1. Release the clamps that secure the air filter cover to the housing.

Vehicle Care

CLEANING THE EXTERIOR

Note: If you use a car wash with a waxing cycle, make sure that you remove the wax from the windshield and the wiper blades.

Note: Prior to using a car wash facility check the suitability of it for your vehicle.

Note: Some car washes use water at high pressure. Due to this, water droplets may enter inside your vehicle and could also damage certain parts of your vehicle.

Note: Remove the aerial before using an automatic car wash.

Note: Switch the heater blower off to prevent contamination of the fresh air filter.

We recommend that you wash your vehicle with a sponge and lukewarm water containing a car shampoo.

Cleaning the Headlamps

Note: Do not scrape the headlamp lenses or use abrasives, alcoholic solvents or chemical solvents to clean them.

Note: Do not wipe the headlamps when they are dry.

Cleaning the Rear Window

Note: Do not scrape the inside of the rear window or use abrasives or chemical solvents to clean it.

Use a clean, lint free cloth or a damp chamois leather to clean the inside of the rear window.

Cleaning the Chrome Trim

Note: Do not use abrasives or chemical solvents. Use soapy water.

Note: Do not apply cleaning product to hot surfaces and do not leave cleaning product on chrome surfaces for a period of time exceeding that which is recommended.

Note: Industrial-strength (heavy-duty) cleaners, or cleaning chemicals, may cause damage over a period of time.

Cleaning the Running Boards Brightwork Trim

Note: Do not use abrasives or harsh chemical solvents. Use stainless steel polishing/cleaning products only, i.e. recommended product Autosol or similar.

Note: Do not apply cleaning product to hot surfaces and do not leave cleaning product on Brightwork Trim surfaces for a period of time exceeding that which is recommended by cleaning product manufacturer.

Body Paintwork Preservation

WARNINGS



Do not polish your vehicle in strong sunshine.



Do not allow polish to touch plastic surfaces. It could be difficult to remove.



Do not apply polish to the windshield or rear window. This could cause the wipers to become noisy and they may not clear the window properly.

We recommend that you wax the paintwork once or twice a year.

CLEANING THE INTERIOR

Note: Do not allow air fresheners and hand sanitizers to spill on interior surfaces. If a spill occurs, wipe off immediately. Damage may not be covered by your warranty.

Seatbelts

Note: Do not use abrasives, or chemical solvents to clean them.

Note: Do not allow moisture to penetrate the seatbelt retractor mechanism.

Vehicle Care

Note: *Cleaning may safely be carried out using mild soap and water . Let them dry naturally, away from artificial heat.*

Instrument Cluster Screens, LCD Screens and Radio Screens

Note: *Do not use abrasives, alcoholic solvents or chemical solvents to clean the instrument cluster screens, LCD screens or radio screens. These cleaning products can damage the screens.*

Clean the instrument panel and cluster lens with a clean, damp and soft cloth, then use a clean, dry and soft cloth to dry these areas.

Rear Windows

Note: *Do not use any abrasive materials to clean the interior of the rear windows.*

Note: *Do not install stickers or labels to the interior of the rear windows.*

Wheels and Tires

GENERAL INFORMATION

A decal with tire pressure data is located in the driver's door opening or on the B pillar.

Check and set the tire pressure at the ambient temperature in which you are intending to drive your vehicle and when the tires are cold.

Note: Check your tire pressures regularly to optimize fuel economy.

Note: Use only approved wheel and tire sizes. Using other sizes could damage your vehicle and will make the National Type Approval invalid.

Note: If you change the diameter of the tires from that fitted at the factory, the speedometer may not display the correct speed. Take your vehicle to an authorized dealer to have the engine management system reprogrammed.

TIRE CARE

Tire Care

Inflating Your Tires

Safe operation of your vehicle requires that your tires are properly inflated. Remember that a tire can lose up to half of its air pressure without appearing flat.

Every day before you drive, check your tires. If one looks lower than the others, use a tire gauge to check the pressure of all tires and adjust if required.

At least once a month and before long trips, inspect each tire and check the tire pressure with a tire gauge (including spare). Inflate all tires to the inflation pressure recommended by the Ford Motor Company.

You are strongly urged to buy a reliable tire pressure gauge, as automatic service station gauges may be inaccurate. Ford recommends the use of a digital or dial-type tire pressure gauge rather than a stick-type tire pressure gauge.

Use the recommended cold inflation pressure for optimum tire performance and wear. Under-inflation or over-inflation may cause uneven treadwear patterns.

WARNING



Under-inflation is the most common cause of tire failures and may result in severe tire cracking, tread separation or blowout, with unexpected loss of vehicle control and increased risk of injury. Under-inflation increases sidewall flexing and rolling resistance, resulting in heat buildup and internal damage to the tire. It also may result in unnecessary tire stress, irregular wear, loss of vehicle control and accidents. A tire can lose up to half of its air pressure and not appear to be flat!

Always inflate your tires to the Ford recommended inflation pressure even if it is less than the maximum inflation pressure information found on the tire. The Ford recommended tire inflation pressure is found on the Tire Label located on door opening or on the B-pillar. Failure to follow the tire pressure recommendations can cause uneven treadwear patterns and adversely affect the way your vehicle handles.

Wheels and Tires

Note: Do not reduce tire pressure to change the ride characteristics of the vehicle. If you do not maintain the inflation pressure at the levels specified by Ford, your vehicle may experience a condition known as shimmy. Shimmy is a severe vibration and oscillation in the steering wheel after the vehicle travels over a bump or dip in the road that does not dampen out by itself. Shimmy may result from significant under-inflation of the tires, improper tires (load range, size, or type), or vehicle modifications such as lift-kits. In the event that your vehicle experiences shimmy, you should slowly reduce speed by either lifting off the accelerator pedal or lightly applying the brakes. The shimmy will cease as the vehicle speed decreases.

Maximum Inflation Pressure is the tire manufacturer's maximum permissible pressure and the pressure at which the maximum load can be carried by the tire. This pressure is normally higher than the manufacturer's recommended cold inflation pressure which can be found next to the driver's seat on the Tire Label located on the B-pillar or the edge of the driver's door. The cold inflation pressure should never be set lower than the recommended pressure on the Safety Compliance Certification Label or Tire Label.

When weather temperature changes occur, tire inflation pressures also change. A 6°C temperature drop can cause a corresponding drop of 0.07 bar in inflation pressure. Check your tire pressures frequently and adjust them to the proper pressure which can be found on the Tire Label.

To check the pressure in your tire(s):

1. Make sure the tires are cool, meaning they are not hot from driving even 1 km.

Note: If you are checking tire pressure when the tire is hot, (for example, driven more than 1.6 km), never bleed or reduce air pressure. The tires are hot from driving and it is normal for pressures to increase above recommended cold pressures. A hot tire at or below recommended cold inflation pressure could be significantly under-inflated.

Note: If you have to drive a distance to get air for your tire(s), check and record the tire pressure first and add the appropriate air pressure when you get to the pump. It is normal for tires to heat up and the air pressure inside to go up as you drive.

2. Remove the cap from the valve on one tire, then firmly press the tire gauge onto the valve and measure the pressure.

3. Add enough air to reach the recommended air pressure.

Note: If you overfill the tire, release air by pressing on the metal stem in the center of the valve. Then recheck the pressure with your tire gauge.

4. Replace the valve cap.

5. Repeat this procedure for each tire, including the spare.

Note: Some spare tires operate at a higher inflation pressure than the other tires. For full-size and dissimilar spare tires, see the Dissimilar spare wheel and tire assembly information for a description. Store and maintain at the higher of the front and rear inflation pressure as shown on the Tire Label.

6. Visually inspect the tires to make sure there are no nails or other objects embedded that could poke a hole in the tire and cause an air leak.

7. Check the sidewalls to make sure there are no gouges, cuts or bulges.

Wheels and Tires

Inspecting Your Tires and Wheel Valve Stems

Periodically inspect the tire treads for uneven or excessive wear and remove objects such as stones, nails or glass that may be wedged in the tread grooves. Check the tire and valve stems for holes, cracks, or cuts that may permit air leakage and repair or replace the tire and replace the valve stem. Inspect the tire sidewalls for cracking, cuts, bruises and other signs of damage or excessive wear. If internal damage to the tire is suspected, have the tire demounted and inspected in case it needs to be repaired or replaced. For your safety, tires that are damaged or show signs of excessive wear should not be used because they are more likely to blow out or fail.

Improper or inadequate vehicle maintenance can cause tires to wear abnormally. Inspect all your tires, including the spare, frequently, and replace them if one or more of the following conditions exist:

Tire Wear

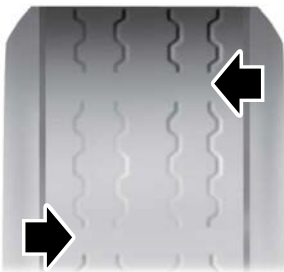

E142546

Tire wear indicators are moulded in to the bottom of the tread grooves to aid in determining when to replace the tire. Tires should be replaced before the tread wears down to the same height as the wear indicators.

Damage

Periodically inspect the tire treads and sidewalls for damage (such as bulges in the tread or sidewalls, cracks in the tread groove and separation in the tread or sidewall). If damage is observed or suspected have the tire inspected by a tire professional. Tires can be damaged during off-road use, so inspection after off-road use is also recommended.

Age

WARNING



Tires degrade over time depending on many factors such as weather, storage conditions, and conditions of use (load, speed, inflation pressure) the tires experience throughout their lives.

In general, tires should be replaced after six years regardless of tread wear. However, heat caused by hot climates or frequent high loading conditions can accelerate the aging process and may require tires to be replaced more frequently.

You should replace your spare tire when you replace the road tires or after six years due to aging even if it has not been used.

Tire Replacement Requirements

Your vehicle is equipped with tires designed to provide a safe ride and handling capability.

WARNINGS



Only use replacement tires and wheels that are the same size, load index, speed rating and type (such as P-metric versus LT-metric or all-season versus all-terrain) as those originally provided by Ford. The recommended tire and wheel size may be found on the Tire Label. Refer to See **Technical Specifications** (page 233). If this

Wheels and Tires

WARNINGS

information is not found on these labels then you should contact your authorized dealer as soon as possible. Use of any tire or wheel not recommended by Ford can affect the safety and performance of your vehicle, which could result in an increased risk of loss of vehicle control, vehicle rollover, personal injury and death. Additionally the use of non-recommended tires and wheels could cause steering, suspension, axle, transfer case or power transfer unit failure. If you have questions regarding tire replacement, contact your authorized dealer as soon as possible.



To reduce the risk of serious injury, when mounting replacement tires and wheels, you should not exceed the maximum pressure indicated on the sidewall of the tire to set the beads without additional precautions listed below. If the beads do not seat at the maximum pressure indicated, re-lubricate and try again.

Important: Remember to replace the wheel valve stems when the road tires are replaced on your vehicle.

The two front tires or two rear tires should generally be replaced as a pair.

The tire pressure sensors mounted in the wheels are not designed to be used in aftermarket wheels.

The use of wheels or tires not recommended by Ford Motor Company may affect the operation of your tire pressure monitoring system.

If the tire pressure monitoring system indicator is flashing, the system is malfunctioning. Your replacement tire might be incompatible with your tire pressure monitoring system, or some component of the system may be damaged.

Safety Practices

WARNINGS



If your vehicle is stuck in snow, mud, or sand, do not rapidly spin the tires; spinning the tires can tear the tire and cause an explosion. A tire can explode in as little as three to five seconds.



Do not spin the wheels at over 56 km/h. The tires may fail and injure a passenger or bystander.

Driving habits have a great deal to do with your tire mileage and safety.

- *Observe posted speed limits.
- *Avoid fast starts, stops and turns.
- *Avoid potholes and objects on the road.
- *Do not run over curbs or hit the tire against a curb when parking.

Highway Hazards

No matter how carefully you drive there's always the possibility that you may eventually have a flat tire on the highway. Drive slowly to the closest safe area out of traffic. This may further damage the flat tire, but your safety is more important.

If you feel a sudden vibration or ride disturbance while driving, or you suspect your tire or vehicle has been damaged, immediately reduce your speed. Drive with caution until you can safely pull off the road. Stop and inspect the tires for damage. If a tire is under-inflated or damaged, deflate it, remove wheel and replace it with your spare tire and wheel. If you cannot detect a cause, have the vehicle towed to the nearest repair facility or tire dealer to have the vehicle inspected.

Wheels and Tires

Tire and Wheel Alignment

A bad jolt from hitting a curb or pothole can cause the front end of your vehicle to become misaligned or cause damage to your tires. If your vehicle seems to pull to one side when you're driving, the wheels may be out of alignment. Have an authorized dealer check the wheel alignment periodically.

Wheel misalignment in the front or the rear can cause uneven and rapid treadwear of your tires and should be corrected by an authorized dealer. Front-wheel drive vehicles and those with an independent rear suspension may require alignment of all four wheels.

The tires should also be balanced periodically. An unbalanced tire and wheel assembly may result in irregular tire wear.

Tire Rotation

WARNING



If the tire label shows different tire pressures for the front and rear tires and the vehicle is equipped with a tire pressure monitoring system, then the settings for the system sensors need to be updated. Always perform the system reset procedure after tire rotation. If the system is not reset, it may not provide a low tire pressure warning when necessary. See the tire pressure monitoring system reset procedure in this chapter.

Note: *If your tires show uneven wear ask an authorized dealer to check for and correct any wheel misalignment, tire imbalance or mechanical problem involved before tire rotation.*

Note: *Your vehicle may be equipped with a dissimilar spare wheel and tire assembly. A dissimilar spare wheel and tire assembly is defined as a spare wheel and tire assembly that is different in brand, size or appearance from the road tires and wheels. If you have a dissimilar spare wheel and tire assembly it is intended for temporary use only and should not be used in a tire rotation.*

Note: *After having your tires rotated, inflation pressure must be checked and adjusted to the vehicle requirements.*

Rotating your tires at the recommended interval of between 5,000 km to 10,000 km will help your tires wear more evenly, providing better tire performance and longer tire life.

Rear-wheel drive vehicles and all-wheel drive vehicles (front tires at left of diagram)

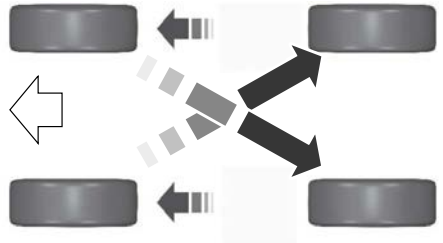

E142548

Sometimes irregular tire wear can be corrected by rotating the tires.

WARNING



Do not scrub the sidewalls of the tires when you are parking.

If you have to mount a curb, do so slowly and approach it with the wheels at right-angles to the curb.

Wheels and Tires

Examine the tires regularly for cuts, foreign objects and uneven wear of the tread. Uneven wear could mean that the wheel alignment is outside specification.

Check the tire pressures (including the spare) when cold, every two weeks.

USING SNOW CHAINS

WARNINGS



Do not exceed 50 km/h.



Do not use snow chains on snow-free roads.



Only fit snow chains to specified tires. See **Technical Specifications** (page 233).



If your vehicle has wheel trims, remove them before fitting snow chains.

Only use snow chains of 10 mm or smaller.

Only use snow chains on the rear axle.

Note: *The anti-lock brake system will continue to operate normally.*

Vehicles with Stability Control

When stability control is on, your vehicle may exhibit some unusual driving characteristics. To reduce this, switch traction control off. See **Using Traction Control** (page 133).

TIRE PRESSURE MONITORING SYSTEM

WARNING



The tire pressure monitoring system is not a substitute for manually checking tire pressures. You should periodically check tire pressures using a pressure gauge. Failure to correctly maintain tire pressures could increase the risk of tire failure, loss of control, vehicle rollover and personal injury.



You must check the tire pressures (including the spare tire where applicable) every two weeks when the tires are cold.

You must inflate the tires to the correct pressure.

See **Wheels and Tires** (page 219). The tire pressures are also on the tire inflation pressure label (located on the edge of driver door or the B-Pillar).

As a driver assistance feature, your vehicle has a tire pressure monitoring system. A warning lamp will illuminate when one or more of the tires are significantly under-inflated. If the low tire pressure warning lamp illuminates, you should stop your vehicle as soon as it is safe to do so, check the tires and inflate them to the correct pressure.

Driving on under-inflated tires can:

- Cause them to overheat.
- Lead to tire failure.
- Reduce fuel efficiency.
- Reduce tire life.
- Affect vehicle handling or stopping ability.

Wheels and Tires

The system is not a substitute for correct tire maintenance.

You must maintain the correct tire pressures, even if low tire pressure has not illuminated the warning lamp.

The tire pressure monitoring system has a system malfunction indicator to warn you when the system is not operating correctly. The malfunction indicator and low tire pressure warning lamp have a combined function. When the system detects a malfunction, the warning lamp will flash for approximately one minute and then remain illuminated. This sequence will occur every time you switch the ignition on while the malfunction remains. The system has detected a fault that requires service.

When the malfunction indicator is illuminated, the system may not be able to detect or signal low tire pressures. A malfunction may occur for a variety of reasons, including the installation of a replacement tire or wheel that prevents the system from functioning correctly. Always check the tire pressure monitoring system malfunction warning after replacing one or more tires or wheels on your vehicle. Make sure the replacement tires or wheels allow the system to continue to function correctly. See **When the Temporary Spare Tire is Installed** in this section.

How Temperature Affects the Tire Pressures

Under normal driving conditions tire pressures may increase by up to 0.3 bar from a cold start situation.

If the vehicle is stationary overnight and the temperature is significantly lower than the daytime temperature, tire pressures may decrease by up to 0.2 bar when there is a drop in the ambient temperature of 17°C or more. The system detects this pressure decrease as being significantly below the correct inflation pressure and the warning lamp illuminates.

Changing Tires With a Tire Pressure Monitoring System



E142549

You should always have tires serviced by an authorized dealer.

Note: Each road wheel and tire is fitted with a tire pressure sensor located inside the wheel and tire assembly cavity. The pressure sensor attaches to the valve stem. The tire covers the pressure sensor and it is not visible unless the tire is removed. Take care when changing the tire to avoid damaging the sensor.

Understanding the Tire Pressure Monitoring System

You must maintain the correct tire pressures, even if low tire pressure has not illuminated the warning lamp.

The system measures the pressure in the road tires and displays a warning lamp in the instrument cluster when a low pressure is detected. See **Tire Pressure Monitoring System** (page 224).

Wheels and Tires

The system detects this lower pressure as being significantly below the correct inflation pressure and the warning lamp illuminates.

When the Temporary Spare Tire is Installed

If you need to replace a road wheel and tire with the temporary spare wheel, the system will continue to identify a defect. This is to remind you to repair the damaged road wheel and tire and refit the repaired road wheel and tire assembly to your vehicle. To restore the correct operation of the system, you must have the repaired road wheel and tire assembly refitted to your vehicle.

When You Believe the System is Not Operating Correctly

The main function of the system is to warn you when the tire pressures are low. It can also warn you in the event the system is no longer capable of operating correctly. See the following chart for information concerning the system:

When Inflating the Tires

When inflating the tires the system may not respond immediately to the air added to the tires.

Wheels and Tires

System Warning Lamps

Warning lamp	Description	Action
Solid warning lamp	Tire(s) under-inflated	<ol style="list-style-type: none"> 1. Make sure tires are at the correct pressure. See Wheels and Tires (page 219). The tire pressures are also on the tire inflation pressure label (located on the edge of driver door or the B-Pillar). 2. After inflating the tires to the correct pressure you must carry out the tire pressure monitoring system reset procedure. See Tire Pressure Monitoring System Reset Procedure in this chapter.
	Spare tire in use	Repair the damaged road wheel and tire and refit the repaired road wheel and tire assembly to your vehicle to restore the correct operation of the system.
	Tire pressure monitoring system malfunction	If the tires are correctly inflated and the spare tire is not in use but the light remains on, the system has detected a fault that requires service.
Solid warning lamp initially followed by a flashing warning lamp	Spare tire in use	Repair the damaged road wheel and tire and refit the repaired road wheel and tire assembly to your vehicle to restore the correct operation of the system.
	Tire pressure monitoring system malfunction	If the tires are correctly inflated and the spare tire is not in use but the light remains on, the system has detected a fault that requires service.

If the Warning Lamp is On:

1. Check each tire to verify that none are flat.
2. If one or more tires are flat, repair as necessary.
3. Check the tire pressures and inflate all the tires to the correct pressure.
4. Carry out the tire pressure monitoring system reset procedure.

Tire Pressure Monitoring System Reset Procedure

Overview

You must carry out the system reset procedure after each tire replacement or adjustment of the tire pressures.

Wheels and Tires

To maintain your vehicle load carrying capability, your vehicle requires different tire pressures in the front tires compared to the rear tires.

The system illuminates the warning lamp at different pressures for the front and rear tires.

The tires need to be periodically rotated to provide consistent performance and maximum tire life, the system needs to know when the tires have been rotated to determine which set of tires are on the front and rear axles. With this information, the system can detect and correctly warn of low tire pressures.

Carrying Out the System Reset Procedure

1. Check the tire pressures and inflate all the tires to the correct pressure.
2. See **Information Displays** (page 67).

To reset the tire pressure monitoring system, scroll to:

Message	Description and Action
Settings	Press the OK button.
Driver assist	Press the OK button.
Tire Monitor	Press and hold the OK button until confirmation appears. Alternatively, if your vehicle has a tire pressure monitoring system reset button, press and hold the button until confirmation appears.

Type Approvals

Refer to for Tire Pressure Monitoring Sensor Radio Frequency Compliance details.





CHANGING A ROAD WHEEL

Lug Nuts

You can obtain replacement locking lug nuts or a locking lug nut key using the from your authorised Ford dealer, using the reference number certificate.

Vehicle Jack

WARNINGS

-  Ensure screwthread is adequately lubricated before use.
-  The jack should be used on level firm ground wherever possible.
-  Switch the ignition off and apply park brake fully before lifting vehicle.
-  It is recommended that the wheels of the vehicle be chocked, and that no person should remain in a vehicle that is being jacked.
-  No person should place any portion of their body under a vehicle that is supported by a jack.

Wheels and Tires

WARNINGS



WARNING: Do not get under a vehicle that is supported by a jack.

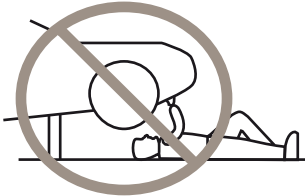

E166722

WARNING



WARNING: The jack supplied with this vehicle is only intended for changing wheels. Do not use the vehicle jack other than when you are changing a wheel in an emergency.

The jack, wheel brace, and winch extension tool are located in the stowage compartment under the rear floor.

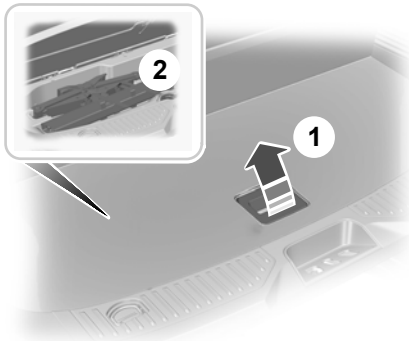

E206399

1. Lift the stowage bin lid.
2. Remove the locking strap and remove the tools.

3. Rotate the retaining nut and remove the jack.

Spare Wheel

Note: *The spare wheel is located underneath the rear of the vehicle.*

1. Assemble the wheel brace and the winch extension tool.
2. Lower the third row seat-back to assist spare wheel winch operation. See **Technical Specifications** (page 233).

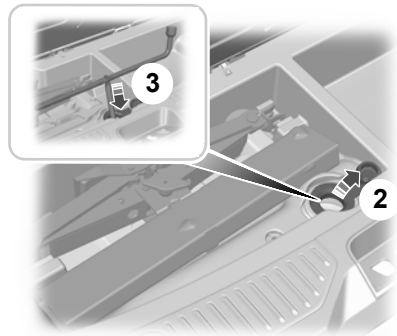

E206440

3. In the rear storage compartment, lift rubber cover to expose wheel winch.
4. Insert the assembled wheel brace and winch extension tool into the guide hole and make sure it locates correctly. Turn the wheel brace counter-clockwise until the spare wheel lowers from underneath the vehicle and rests on the ground, and there is slack in the cable.

Wheels and Tires

5. Pass the bracket and cable through the wheel opening.

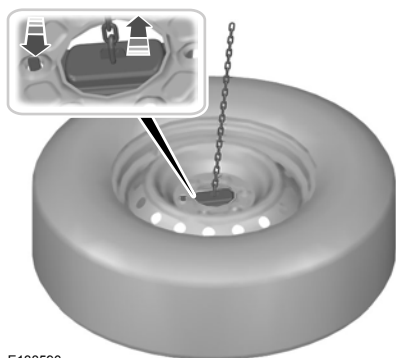

E133590

Jacking and Lifting Points

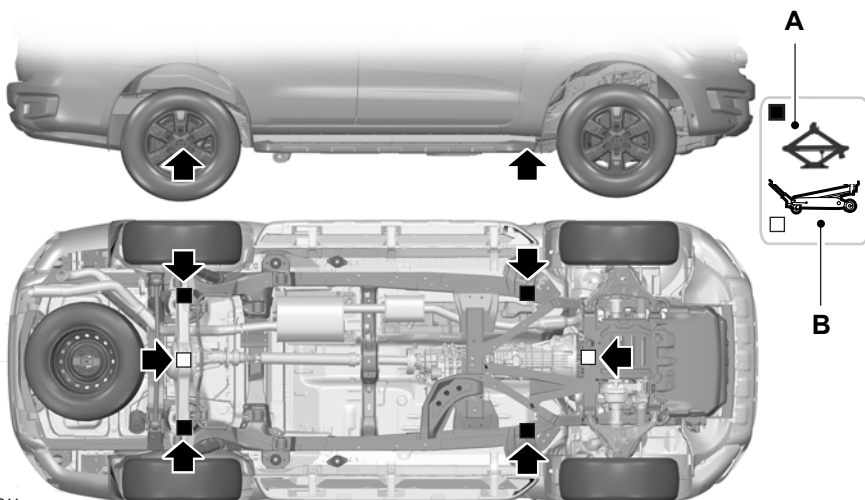

E206244

Wheels and Tires

- A Emergency use only (vehicle jack).
- B Maintenance (trolley jack).

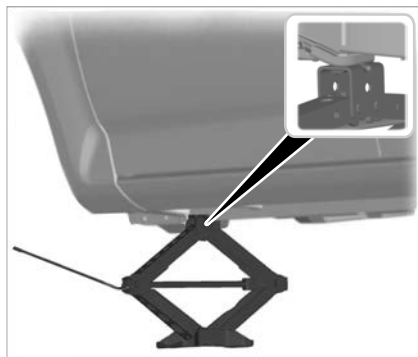





WARNING



-  Use only the specified jacking points. If you use other positions, you may damage the body, steering, suspension, engine, braking system or the fuel lines.

Removing a Road Wheel

WARNINGS

-  Park your vehicle in such a position that neither the traffic nor you are hindered or endangered.
-  Make sure that the wheels are pointing straight ahead.
-  If your vehicle has a manual transmission, move the selector lever to first or reverse gear. If it has an automatic transmission, move the selector lever to position **(P)**.
-  Secure the diagonally opposite wheel with an appropriate block or wheel chock.

WARNINGS

-  Make sure that the jack is vertical to the jacking point and the base is flat on the ground.
-  Never place anything between the vehicle jack and your vehicle.

Note: Do not lay alloy road wheels face down on the ground.

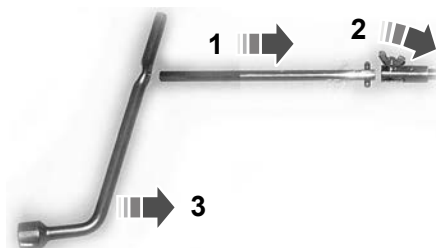

1. Assemble the wheel brace and winch extension tool.
2. Insert the assembled wheel brace and winch extension tool into the vehicle jack and raise your vehicle until the tire is clear of the ground.

Wheels and Tires

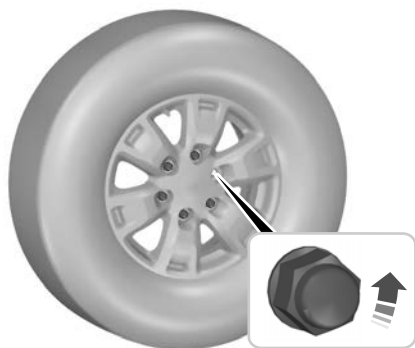

E134693

- Using the wheel brace, remove the lug nuts and the road wheel.

Installing a Road Wheel

WARNINGS

 Use only approved wheel and tire sizes. Using other sizes could damage your vehicle and cause irregular handling and operating characteristics. See **Technical Specifications** (page 233).

 Make sure there is no grease or oil on the threads or the surface between the wheel lugs and nuts. This can cause the lug nuts to loosen while driving.

 Have the tightening torque of the wheel nuts and the tire pressure checked as soon as possible.

Note: Make sure the wheel and hub contact surfaces are free from foreign matter.

Note: Make sure that the cones on the lug nuts are against the wheel.

- Install the wheel.
- Install the lug nuts and finger tight.
- Install the locking lug nut key.

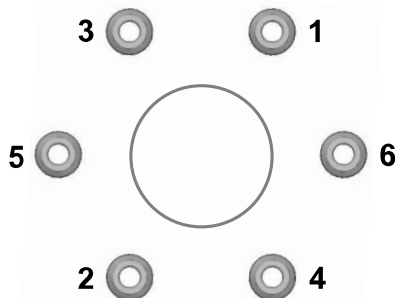

E79156

- Install all of the lug nuts and partially tighten them in the sequence shown.
- Lower your vehicle and remove the vehicle jack.
- Fully tighten all of the lug nuts in the sequence shown using the wheel brace. See **Technical Specifications** (page 233).
- Position the projection of the cap and the projection of the hub correctly.

WARNING

 Have the lug nuts checked for tightness and the tire pressure checked as soon as possible.

Note: If the spare wheel is different in size or construction to the road wheels, have this corrected as soon as possible.

Stowing the Flat Tire

WARNING

 Do not raise the spare wheel carrier without the wheel attached. Damage can occur to the winch mechanism if lowered without a wheel attached.

- Place the wheel flat on the ground, with the outer face of the wheel facing down down.

Wheels and Tires

2. Tilt the bracket, and pass it through the center of the wheel.
3. Insert the winch extension tool into the winch and turn clockwise.
4. Stow the wheel brace, vehicle jack and winch extension tool away.

TECHNICAL SPECIFICATIONS

Wheel Nut Torque

Vehicle Type	Torque
All	135 Nm

Tire Pressures (Cold Tires)

Tire Size	Normal Load		ECO**		Full Load	
	Front	Rear	Front	Rear	Front	Rear
265/65 R17 112T*	210 kPa / 30 psi	210 kPa / 30 psi	240 kPa / 35 psi	240 kPa / 35 psi	240 kPa / 35 psi	300 kPa / 44 psi
265/60 R18 110T*	210 kPa / 30 psi	210 kPa / 30 psi	240 kPa / 35 psi	240 kPa / 35 psi	240 kPa / 35 psi	300 kPa / 44 psi
265/50 R20 107T*	240 kPa / 35 psi	240 kPa / 35 psi	N/A	N/A	240 kPa / 35 psi	300 kPa / 44 psi

*Only fit snow chains to specified tires.

** ECO tire inflation pressures are recommended for optimal fuel consumption.

Capacities and Specifications

VEHICLE DIMENSIONS

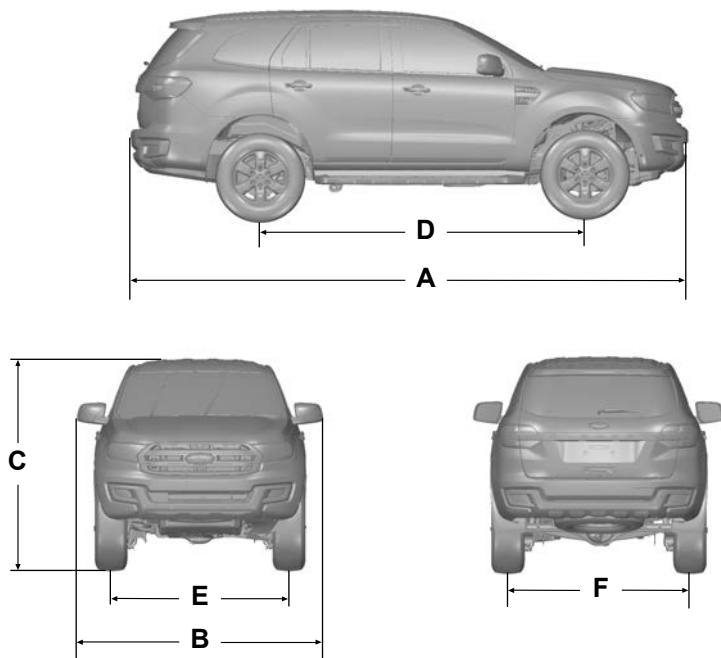

E200432

Callout	Dimension Description	mm
A	Maximum length.	4,892 mm
B	Overall width including exterior mirrors.	2,180 mm
C	Overall height	1,837 mm

Capacities and Specifications

Callout	Dimension Description	mm
D	Wheelbase.	2,850 mm
E	Front track.	1,560 mm
F	Rear track.	1,564 mm

Capacities and Specifications

VEHICLE IDENTIFICATION PLATE

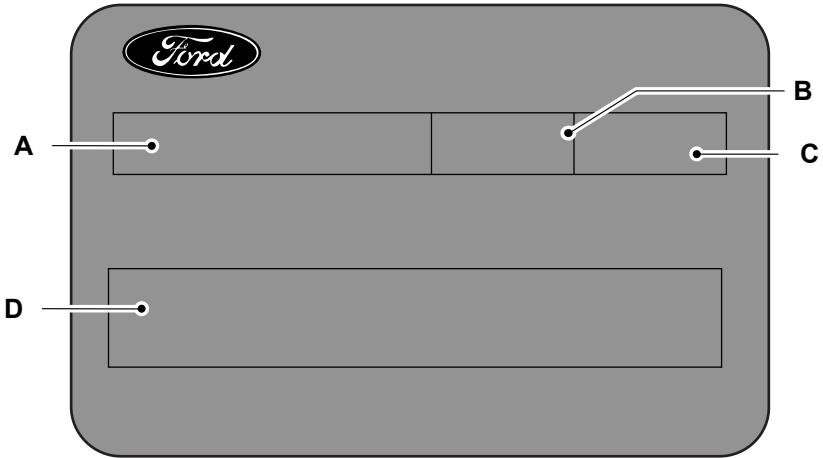

E213504

- A Model
- B Paint Code
- C "Built Date"
- D Vehicle Identification Number (VIN)

The label with your vehicle built date is located on the bottom of the lock side of the passenger door aperture.

"Built Date"

"Built date" means the calendar month and the year in which the body shell and power train sub-assemblies are conjoined and the vehicle is driven or moved from the production line.

Capacities and Specifications

VEHICLE IDENTIFICATION NUMBER

The vehicle identification number is on the left-hand side of the instrument panel.

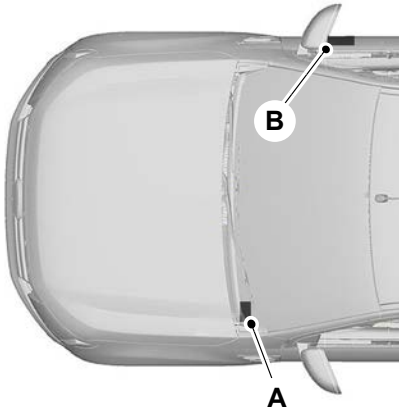

E133363

The vehicle identification number is also stamped beneath the front door on the chassis, on the right-hand side.

ENGINE NUMBER

2.0L Engine Number

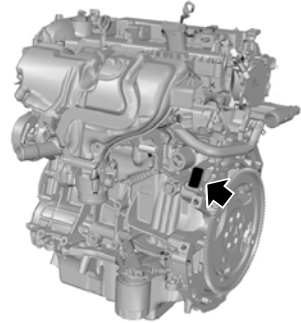

E206722

The engine number is stamped on the cylinder block.

2.0L Engine sticker

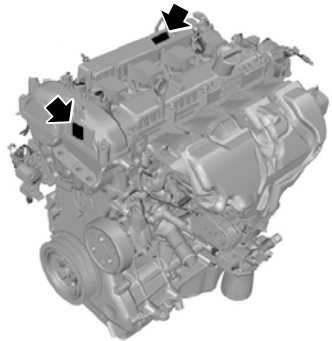

E214683

There are engine stickers on the valve cover and engine front cover.

Capacities and Specifications

2.2L Engine Number

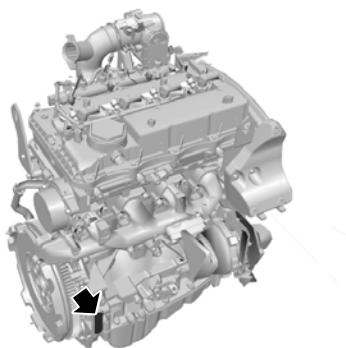

E210233

The engine number is stamped on the cylinder block.

2.2L Engine sticker

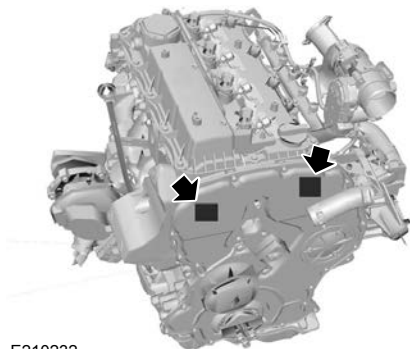

E210232

There are engine stickers on the engine front cover.

Audio System

GENERAL INFORMATION

Radio Frequencies and Reception Factors

Radio reception factors	
Distance and Strength	The further you travel away from an FM station, the weaker the signal and the weaker the reception.
Terrain	Hills, mountains, tall buildings, bridges, tunnels, freeway overpasses, parking garages, dense tree foliage and thunderstorms can interfere with the reception.
Station overload	When you pass near a radio transmission tower, a stronger signal can override a weaker signal and can cause interference in the audio system.

CD and CD Player Information

Note: *CD units play commercially pressed 4.75-inch (12 centimeter) audio compact discs only. Due to technical incompatibility, certain recordable and re-recordable compact discs may not function correctly when used in Ford CD players.*

Note: *Do not insert CDs with homemade paper (adhesive) labels into the CD player as the label may peel and cause the CD to become jammed. You should use a permanent felt tip marker rather than adhesive labels on your homemade CDs. Ballpoint pens may damage CDs. Please contact an authorized dealer for further information.*

Note: *Do not use any irregularly shaped discs or discs with a scratch protection film attached.*

Always handle discs by their edges only. Clean the disc with an approved CD cleaner only. Wipe it from the center of the disc toward the edge. Do not clean in a circular motion.

Do not expose discs to direct sunlight or heat sources for extended periods.

MP3 and WMA Track and Folder Structure

Audio systems capable of recognizing and playing MP3 and WMA individual tracks and folder structures work as follows:

- There are two different modes for MP3 and WMA disc playback: MP3 and WMA track mode (system default) and MP3 and WMA folder mode.
- MP3 and WMA track mode ignores any folder structure on the MP3 and WMA disc. The player numbers each MP3 and WMA track on the disc (noted by the MP3 or WMA file extension) from T001 to a maximum of T255. The maximum number of playable MP3 and WMA files may be less depending on the structure of the CD and exact model of radio present.

Audio System

- MP3 and WMA folder mode represents a folder structure consisting of one level of folders. The CD player numbers all MP3 and WMA tracks on the disc (noted by the MP3 or WMA file extension) and all folders containing MP3 and WMA files, from F001 (folder) T001 (track) to F253 T255.
- Creating discs with only one level of folders helps with navigation through the disc files.

If you are burning your own MP3 and WMA discs, it is important to understand how the system reads the structures you create. While various files may be present, (files with extensions other than MP3 and WMA), only files with the MP3 and WMA extension are played; other files are ignored by the system. This enables you to use the same MP3 and WMA disc for a variety of tasks on your work computer, home computer and your in-vehicle system.

In track mode, the system displays and plays the structure as if it were only one level deep (all MP3 and WMA files play, regardless of being in a specific folder). In folder mode, the system only plays the MP3 and WMA files in the current folder.

AUDIOUNIT - VEHICLES WITH: AM/FM/CD/SYNC/DAB/ TOUCHSCREEN DISPLAY

WARNING



Driving while distracted can result in loss of vehicle control, crash and injury. We strongly recommend that you use extreme caution when using any device that may take your focus off the road. Your primary responsibility is the safe operation of your vehicle. We recommend against the use of any hand-held device while driving and encourage the use of voice-operated systems when possible. Make sure you are aware of all applicable local laws that may affect the use of electronic devices while driving.

Audio System

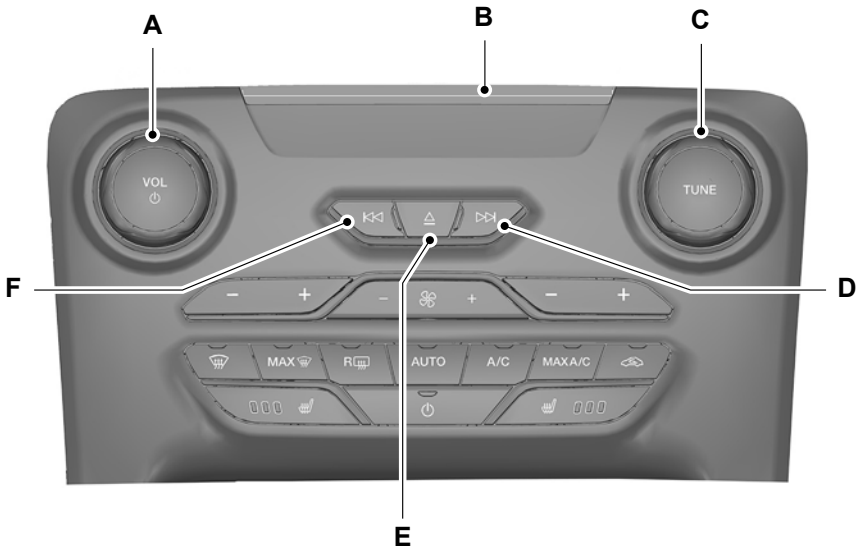

E200470

- A **VOL and Power:** Press this button to turn the system off and on. Turn it to adjust the volume.
- B **CD slot:** Insert a CD.
- C **TUNE:** Once you select a frequency band, turn the control to find the desired station manually.
- D **Seek and Fast Forward:** In radio mode, select a frequency band and press this button. The system stops at the first station up the band. Press and hold the button to move quickly to the next strong radio station or memory preset. In CD mode, press this button to select the next track. Press and hold the button to move quickly forward through the current track.
- E **Eject:** Press this button to eject a CD.
- F **Seek and Reverse:** In radio mode, select a frequency band and press this button. The system stops at the first station down the band. Press and hold the button to move quickly to the previous strong radio station or memory preset. In CD mode, press this button to select the previous track. Press and hold the button to move quickly backward through the current track.

Audio System

AUDIO UNIT CLOCK AND DATE DISPLAYS

Changing the Time

The clock can be set at any time when the system is in the one hour mode or the ignition switch is in the ACC or ON position.

Note: Vehicles with AM/FM/DAB/CD: The time can be adjusted using the hour and minute buttons on the screen.

To advance the hours, press the **HOUR SET** button. To advance the minutes, press the **MINUTE SET** button while the time is flashing.

Note: Vehicles with Bluetooth/NAV: The time can be adjusted using the clock button on the audio control panel.

Note: The time can be adjusted using the cursor arrow buttons on the audio control panel.

Vehicles with AM/FM/DAB/USB/Bluetooth

1. Press the **MENU** button.
2. Use the up and down arrow button to select the clock settings.
3. Short press the **OK** button or right arrow button to enter the clock settings.
4. Use the up and down arrow button to select the set time.
5. Use the up and down arrow button to adjust hours.
6. Use the right and left arrow button to scroll to the minutes.
7. Use the up and down arrow button to adjust minutes.
8. Use the OK button to save the settings.

Vehicles with AM/FM/DAB/CD/SYNC

1. Press the **MENU** button.

2. Use the up and down arrow button to select the clock settings.
3. Press **OK** button or right arrow button to enter clock settings.
4. Use the up and down arrow button to select the set time.
5. Use the up and down arrow button to adjust hours.
6. Use the right and left arrow button to scroll to the minutes.
7. Use the up and down arrow button to adjust minutes.
8. Use the **OK** button to save the settings.

Vehicles with AM/FM/DAB/CD/SYNC 2

Exact Hour Adjustment

You can set the time to the beginning of an hour using this feature.

- Press the **CLOCK** button for about two seconds until a beep is heard. The clock's current time will flash.
- Press the **CLOCK** button again and the time will be adjusted as follows:

Example

- Current set time between 12:01 and 12:29 will change to 12:00 exactly.
- Current set time between 12:30 and 12:59 will change to 1:00 exactly.

Note: If the power supply to the unit is interrupted (if the fuse blows or the vehicle's battery is disconnected), the clock will need to be reset.

COMPACT DISC PLAYER

Compact Disc Playback

Note: During playback, the display indicates the disc, track and time that have elapsed since the start of the track.

Audio System

During radio reception, press **CD** once to start CD playback.

After a disc is loaded, playback starts immediately.

Track Selection

- Press the seek up once to move to the next track or press it repeatedly to access later tracks.
- Press the seek down once to replay the current track. If pressed within two seconds of the start of a track, the previous track plays.
- Press the seek down repeatedly to select previous tracks.
- Press the up or down arrow to select the required track, then press **OK**.

You can select a track by using the numeric keypad. Dial the required track number until complete (for example, 1 then 2 for track 12), or dial the number and directly press **OK**.

Fast Forward and Reverse

Press and hold the seek down or up to search backward or forward within the tracks on the disc.

Shuffle and Random

Random track playback, also known as shuffle, plays all tracks on the CD in random order.

Type 1

Press the **SHUFFLE** in CD mode.

Note: *When an MP3 CD is playing, you can have the system shuffle tracks for the whole CD, or within the current folder.*

Type 2

Press the **MENU** and select CD MODE.

Select **SHUFFLE**, which then enables the function to be selected on or off.

Note: *When an MP3 CD is playing, you can have the system shuffle tracks for the whole CD, or within the current folder.*

Type 3

Press function button 2.

Note: *When an MP3 CD is playing, you can have the system shuffle tracks for the whole CD, or within the current folder. Pressing function button 2 toggles these options.*

Use the seek up or down button to select the next track to shuffle, if required.

Repeat Compact Disc Tracks

Type 1

Press **REPEAT** in CD mode.

Note: *When an MP3 CD is playing, you can have the system repeat the current track or all tracks within the current folder.*

Type 2

Press the **MENU** button and select CD MODE.

Select **REPEAT**, which then enables the function to be selected on or off. The track will replay once ended.

Note: *When an MP3 CD is playing, you can have the system repeat the current track or all tracks within the current folder.*

Type 3

Press function button 1.

Note: *When an MP3 CD is playing, you can have the system repeat the current track or all tracks within the current folder. Pressing function button 1 toggles these options.*

Compact Disc Track Scanning

The Scan function allows you to preview each track for approximately 8 seconds.

Audio System

Type 1

Press **CD** to select CD MODE.

Short press **SCAN** button to scan CD.

Note: *When an MP3 CD is playing, you can have the system scan tracks on the CD or within the current folder. Pressing **SCAN/AS** button toggles these options.*

Type 2

Various scan modes are possible, according to the type of CD currently playing.

Press the **MENU** button and select CD MODE.

Select **SCAN**, which then enables the function to be selected on or off.

Note: *When an MP3 CD is playing, you can have the system scan tracks on the CD or within the current folder. Pressing **OK** button toggles these options.*

Type 3

Press function button 3.

Note: *When an MP3 CD is playing, you can have the system scan tracks on the CD or within the current folder. Pressing function button 3 toggles these options.*

MP3 File Playback

MP3 (MPEG1 Audio Layer-3) is a standard technology and format for compressing audio data. This allows a more efficient use of the media.

You can play MP3 files recorded on CD-ROM, CD-R and CD-RW formats. The disc must be in the ISO 9660 level 1 or level 2 format, or Joliet or Romeo in the expansion format. You can also use a disc recorded in multi session.

ISO 9660 Format

This is the most common international standard for the logical format of files and folders on a CD-ROM.

There are several specification levels. In Level 1, file names must be in the 8.3 format (no more than eight characters in the name, no more than three characters in the extension MP3 and WMA) and in capital letters.

Folder names can be no longer than eight characters. There can be no more than eight folder levels (trees). Level 2 specifications allow file names up to 31 characters long.

Each folder can have up to eight trees.

For Joliet or Romeo in the expansion format, consider these restrictions when configuring your CD writing software.

Multi Session

This recording method enables adding of data using the track-at-once method.

Conventional CDs begin at a CD control area called the lead-in and end at an area called lead-out. A multi session CD is a CD having multiple sessions, with each segment from lead-in to lead-out regarded as a single session.

CD-Extra: The format that records audio (audio CD data) as tracks on session 1, and records data as tracks on session 2.

Mixed CD: In this format, data records as track 1 and audio (audio CD data) records as track 2.

File Formats

With formats other than ISO 9660 level 1 and level 2, folder names or file names may not display correctly.

When naming, be sure to add the file extension MP3 to the file name.

Audio System

If you put the extension MP3 to a file other than MP3, the unit cannot recognize the file correctly and generates random noise that could damage your speakers.

The following discs take a longer time to start playback.

- A disc recorded with complicated tree structure.
- A disc recorded in multi session.
- A non-finalized disc, where you can add more data.

Playing a Multi Session Disc

When the first track of the first session is audio CD data only, the audio CD data of the first session plays. Non-audio CD data, MP3 file information (such as track number and time) displays with no sound.

When the first track of the first session is not audio CD data:

- If an MP3 file is on the disc, the system skips these file and other data. Audio CD data is not recognized.
- If no MP3 file is in the disc, nothing plays. Audio CD data is not recognized.

MP3 Files Playback Order

The playback order of the folders and files are as shown.

Note: *The system skips any folder that does not include an MP3 file.*

To specify a desired playback order before the folder or file name, input the order by number (for example, 01 or 02) then record the contents onto a disc. The order differs depending on the writing software.

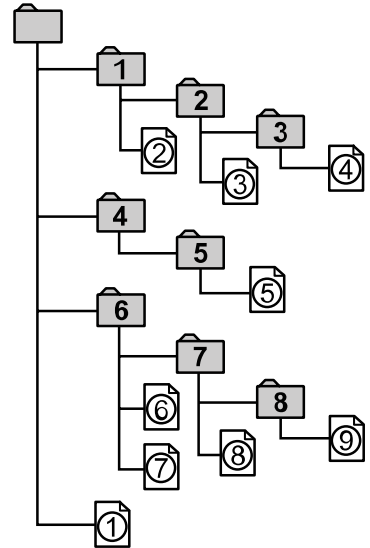

ID3 Tag Version 2

The following occurs when an MP3 file containing a tag plays:

- When skipping a portion of a tag (at the beginning of the track) there is no sound output. Skip time changes depending on the tag capacity. Example: At 64 kbytes, it is about 2 seconds (with RealJukebox).
- The displayed elapsed playing time when skipping a portion of the tag is inaccurate. For MP3 files of a bit rate other than 128 kbps, time does not display accurately during playback.
- When an MP3 file is created with MP3 conversion software (such as RealJukebox - a registered trademark of RealNetworks Inc.), the tag generates automatically.

Audio System

MP3 Navigation

You can record MP3 tracks on the CD in several ways. You can place them in the root directory like a conventional audio CD, or in folders that may represent categories, such as album, artist, or genre.

The normal playing sequence on CDs with multiple folders is:

- Play the tracks within the root (top level) first.
- Then the tracks in any folder(s) within the root.
- Then move onto the second folder, and so forth.

To navigate to a track:

1. Press the up or down arrow buttons to enter the track list.
2. Navigate the hierarchy using the arrow buttons to select another folder or track (file).
3. Press **OK** to select a highlighted track.

MP3 Display Options

When an MP3 disc is playing, certain information encoded in each track can display. Such information normally includes:

- The file name.
- The folder name.
- ID3 information, which might be the album or artist name.

The unit normally shows the file name that is playing. To select one of the other items of information, press **INFO** repeatedly until the required item appears in the display.

CD Text Display Options

When an audio disc with CD text is playing, limited information encoded in each track can display. Such information normally includes:

- The disc name.
- The artist name.
- The track name.

Note: You can select these display options in the same way as MP3 displays.

Ending Compact Disc Playback

To restore radio reception on all units, press **RADIO**.

Note: The CD does not eject. The disc pauses at the point where radio reception returned.

To resume CD playback, press **CD** again.

MEDIA HUB (If Equipped)

Type 1



E217515

A LINE IN.

Audio System

Type 2

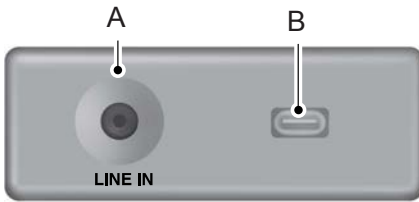

E217516

- A LINE IN.
- B USB ports.

Type 3

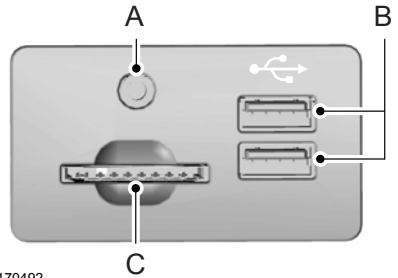

E170492

- A LINE IN.
- B USB ports.
- C SD card slot.

AUDIO TROUBLESHOOTING

Audio unit display	Rectification
Please check CD	General error message for CD fault conditions, for example cannot read the CD, data-CD inserted, etc. Make sure the disc is loaded correctly. Clean and re-try, or replace disc with known music disc. If error persists contact an authorized dealer.
CD drive malfunction	General error message for CD fault conditions. For example a mechanism fault.
CD drive high temp.	Ambient temperature too hot – unit will not work until it has cooled down.

GENERAL INFORMATION

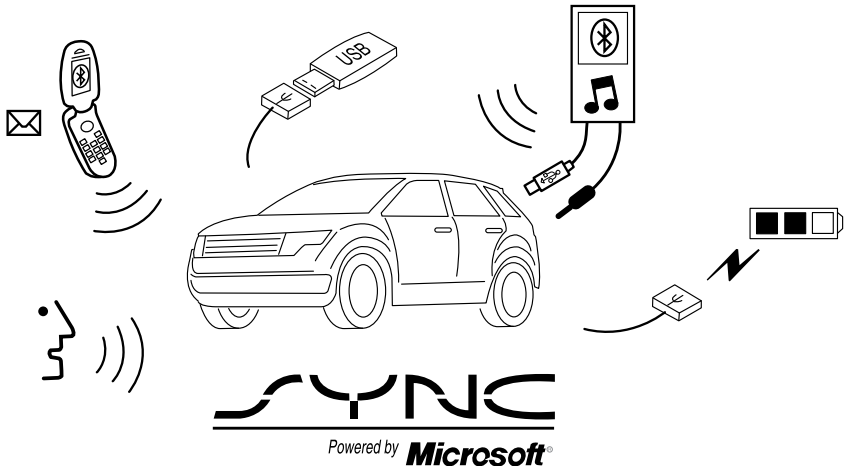

E142598

SYNC is an in-vehicle communications system that works with your Bluetooth-enabled cell phone and portable media player.

This allows you to:

- Make and receive calls
- Access and play music from your media player
- Use Emergency Assistance and applications, via SYNC AppLink*
- Access phonebook contacts and music using voice commands
- Stream music from your connected cell phone
- Select pre-defined text messages (if your device supports this)

- Use the advanced voice recognition system
- Charge your USB device (if your device supports this)

*These features are not available in all markets and may require activation. Available AppLink enabled apps vary by market.

Make sure that you review your device's manual before using it with SYNC.

Support

For further support, see an authorized dealer. For more information, visit the regional Ford website.

Safety Information

WARNING



Driving while distracted can result in loss of vehicle control, crash and injury. We strongly recommend that you use extreme caution when using any device that may take your focus off the road. Your primary responsibility is the safe operation of your vehicle. We recommend against the use of any hand-held device while driving and encourage the use of voice-operated systems when possible. Make sure you are aware of all applicable local laws that may affect the use of electronic devices while driving.

When using SYNC:

- Do not operate playing devices if the power cords or cables are broken, split or damaged. Carefully place cords and cables where you cannot step on them or they do not interfere with the operation of pedals, seats, compartments or safe driving abilities.
- Do not leave playing devices in your vehicle during extreme conditions as it could cause them damage. Refer to your device's manual for further information.
- Do not attempt to service or repair the system. See an authorized dealer.

Privacy Information

When a cell phone is connected to SYNC, the system creates a profile that is linked to that cell phone. The system creates the profile to offer you more mobile features and to operate more efficiently. Among other things, this profile may contain data about your phonebook, text messages (read and unread) and call history. This will include the history of calls when your cell phone was not connected to the system. If you connect a media player, the system creates and retains an index of

supported media content. The system also records a short development log of approximately 10 minutes of all recent system activity. The log profile and other system data may be used to improve the system and help diagnose any problems that may occur.

The cell phone profile, media player index and development log will remain in the system unless deleted. They are generally accessible in your vehicle only when you connect your cell phone or media player. If you no longer plan to use the system or your vehicle, we recommend you complete a master reset to erase all stored information. See **SYNC™** (page 248).

Special equipment is required to access system data. Access to your vehicle's SYNC module is also required. We will not access the system data for any purpose other than as described without consent. Examples where system data can be accessed are for a court order, where required by law enforcement, other government authorities or other third parties acting with lawful authority. Other parties may seek to access the information independently of us. Further privacy information is available. See **SYNC™ Applications and Services** (page 263).

USING VOICE RECOGNITION

This system helps you control many features using voice commands. This allows you to keep your hands on the steering wheel and focus on what is in front of you.

Helpful Hints

Make sure the interior of your vehicle is as quiet as possible. Wind noise from open windows and road vibrations may prevent the system from correctly recognizing spoken commands.

Before giving a voice command, wait for the system announcement to finish followed by a single beep. Any command spoken before this does not register with the system.

Speak naturally, without long pauses between words.

You can interrupt the system at any time while it is speaking by pressing the voice button. You can also cancel a voice session at any time by pressing and holding the voice button.

Initiating a Voice Session



Press the voice button located on the steering wheel. A list of available commands appears in the display.

Global voice commands	
(cancel stop exit)	This command ends the voice session. You can also cancel a session by holding the voice button for two or more seconds.
help	This command provides you with hints, examples and instructions.
main menu	This command restarts the voice session from the initial starting point.

System Interaction and Feedback

The system provides feedback through audible tones, prompts, questions and spoken confirmations depending on the situation and your chosen level of interaction. You can customize the voice recognition system to provide more or less instruction and feedback.

The default setting is to a higher level of interaction in order to help you learn to use the system. You can change these settings at any time.

Adjusting the Interaction Level



Press the voice button. When prompted:

Command	Description
voice settings	Provides access to change the interaction level.

Then any of the following:

Command	Description
interaction mode advanced	Provides less audible interaction and more tone prompts.
interaction mode novice	Provides more detailed interaction and guidance.

Confirmation prompts are short questions the system asks when it is not sure of your request or when there is more than one possible response to your request. For

example, the system may ask if the command phone is correct.

Press the voice button. When prompted:

Command	Description
voice settings	Provides access to change the confirmation prompt setting.

Then any of the following:

Command	Description
confirmation prompts off	Makes a best guess from the command. You may still occasionally be asked to confirm settings.
confirmation prompts on	Clarifies your voice command with a short question.

The system creates suggestion lists when it has the same confidence level of several options based on your voice commands. When switched on, the system may prompt you with as many as four possibilities for clarification.

Command	Description
media candidate lists off	Makes a best guess from the media suggestion list. The system may occasionally ask you questions.
media candidate lists on	Clarifies your voice command for media suggestions.
phone candidate lists off	Makes a best guess from the cell phone suggestion list. The system may occasionally ask you questions.
phone candidate lists on	Clarifies your voice command for cell phone suggestions.

Press the **MENU** button.

Changing the Voice Settings

You can change the voice settings using the information and entertainment display.

You can then select the following:

Action	Message
SYNC-Settings	
Voice settings	Enters menu for voice options.

USING SYNC™ WITH YOUR PHONE

Hands-free calling is one of the main features of SYNC. While the system supports a variety of features, many are dependent on your cell phone's functionality.

At a minimum, most cell phones with Bluetooth wireless technology support the following functions:

- Answering an incoming call.
- Ending a call.
- Using privacy mode.
- Dialing a number.
- Redialing.
- Call waiting notification.
- Caller ID.

Other features such as text messaging using Bluetooth and automatic phonebook download are cell phone dependent features. To check your cell phone's compatibility, refer to your device's manual or visit the regional Ford website.

Pairing a Cell Phone For the First Time

Wirelessly pairing your cell phone with the system allows you to make and receive hands-free calls.

Note: You must switch the ignition and radio on.

Note: To scroll through the menus, press the up or down arrows on your audio system.

1. Make sure the Bluetooth feature on your cell phone is switched on before starting the search. Refer to your device's manual if necessary.
2. Press the **PHONE** button. When the audio display indicates that no phones are paired, select the option to add.
3. When a message to begin pairing appears in the audio display, search for SYNC on your cell phone to start the pairing process.
4. Select SYNC on your cell phone.
5. Wait until the PIN appears on the phone display. Compare the PIN on the phone with the PIN shown in the audio display and accept the request on the phone and the vehicle display. The display indicates when the pairing is successful.

Note: In some cases the phone will request to enter a PIN. Enter the six-digit PIN provided by the system in the audio display. The display indicates when the pairing is successful.

Depending on your cell phone's capability and your market, the system may prompt you with questions such as setting the current cell phone as the primary cell phone (the cell phone the system automatically tries to connect with first when you switch the ignition on) or downloading your phonebook.



The information display may show your cell phone's battery charge level and signal strength.

Using Voice Commands



Make sure to switch on your phone's Bluetooth feature before starting the search. See your device's manual if necessary.

Press the voice button and when prompted say:

Voice Command	Action and Description
(pair ([Bluetooth] device phone Bluetooth audio) add phone)	Follow the instructions on the audio display.

Words in square brackets [] are optional and do not have to be spoken for the system to understand the command.

Depending on your phone's capability and your market, the system may prompt you with questions, such as setting the current phone as the primary phone (the phone SYNC automatically tries to connect with first upon vehicle start-up) and downloading your phonebook.

Pairing Subsequent Cell Phones

Wirelessly pairing your cell phone with the system allows you to make and receive hands-free calls.

Note: You must switch the ignition and radio on.

Note: To scroll through the menus, press the up or down arrows on your audio system.

1. Make sure the Bluetooth feature on your cell phone is switched on before starting the search. Refer to your device's manual if necessary.
2. Press the **PHONE** button.
3. Select the option for Bluetooth devices.
4. Press the **OK** button.
5. Select the option to add. This starts the pairing process.
6. When a message to begin pairing appears in the audio display, search for SYNC on your device to start the pairing process.
7. Select SYNC on your cell phone.
8. Wait until the PIN appears on the phone display. Compare the PIN on the phone with the PIN shown in the audio display and accept the request on the phone and the vehicle display. The display indicates when the pairing is successful.

Note: In some cases the phone will request to enter a PIN. Enter the six-digit PIN provided by the system in the audio display. The display indicates when the pairing is successful.

The system may prompt you with questions such as setting the current cell phone as the primary cell phone or downloading your phonebook.

Cell Phone Voice Commands



Press the voice button and when prompted say:

Voice Command
(phone Blackberry iPhone)
Then say any of the following:
call (___)
call ___ at home
call ___ ([at] work [(in at) [the]] office)
call ___ on (mobile cell)
call ___ on other
dial [[a] number] 1
([go to] privacy [on] transfer to phone handsfree off) 2
(hold call [on] place call on hold) 2
join (calls call) 2
mute call [on] 2

Voice Command
(mute call off un-mute call) 2
(turn ringer on silent mode off)
(turn ringer off silent mode [on])
[text] (messages message) 3
help

___ is a dynamic listing, meaning that it could be the name of anything, such as a group, artist or song. For example you could say "Play artist The Beatles".

¹ See **Dial** table below.

² These commands are only valid while in a phone call.

³ See the text message table below.

Dial Commands

Press the voice button and when prompted say any of the following commands:

Voice Command	Action and Description
Pound	This will add a # symbol to the number or name.
Number	0 (zero) to 9 (nine)
Asterisk or Star	This will add a * symbol to the number or name.
clear	Deletes all entered digits
(delete correct)	Deletes the last set of entered digits.
Plus	This will add a + symbol to the number or name.

Note: To exit dial mode, press and hold the phone button or any button on the audio unit.

Phonebook Hints

To hear how the SYNC system speaks a name browse phonebook, select a contact and press:

Menu Item
Hear it

Making a Call

Press the voice button and when prompted say either:

Voice Command	Action and Description
call [[a] name]	
dial [[a] number]	SYNC prompts you to say the numbers that you wish to dial. After you say the numbers, the system confirms it.

When the system has stated the number, you say any of the following:

Voice Command	Action and Description
(dial send)	This initiates the call.
(delete correct)	To erase the last spoken digit.
clear	To erase all spoken digits.

To end the call, press the end call button on the steering wheel or select the end call option in the audio display and press **OK**.

Receiving a Call

When receiving a call, you can:

- Answer the call by pressing the accept call button on the steering wheel or by selecting the accept call option in the audio display and pressing the **OK** button.
- Reject the call by pressing the reject call button on the steering wheel or by selecting the reject call option in the audio display and pressing the **OK** button.
- Ignore the call by doing nothing.

Cell Phone Options During an Active Call

During an active call, you have extra menu features which become available, for example putting a call on hold.

To access this menu, choose one of the options available at the bottom of the audio display or select the option for more.

Menu Item	Action and Description
Mic. off	Turn your vehicle's microphone off. To turn the microphone on, select the option again.
Privacy	Switch a call from an active hands-free environment to your cell phone for a more private conversation. When selected, the audio display will indicate the call is private.
Hold	Put an active call on hold. When selected, the audio display will indicate the call is on hold.

Menu Item	Action and Description
Dial a number	Enter numbers using the audio system numeric keypad, for example numbers for passwords.
Join calls	<p>Join two separate calls. The system supports a maximum of three callers on a multi-party or conference call.</p> <ol style="list-style-type: none"> 1. Select the option for more. 2. Access the desired contact through the system or use voice commands to place the second call. Once actively in the second call, select the option for more. 3. Scroll to the option to join calls and press the OK button.
Phonebook	<p>Access your phonebook contacts.</p> <ol style="list-style-type: none"> 1. Select the option for more. 2. Scroll to the option for phonebook and press the OK button. 3. Scroll through your phonebook contacts. 4. Press the OK button again when the desired selection appears in the audio display. 5. Press the OK button or dial button to call the selection.
Call history	<p>Access your call history log.</p> <ol style="list-style-type: none"> 1. Select the option for more. 2. Scroll to the option until call history appears. Press the OK button. 3. Scroll through your call history options (incoming, outgoing or missed). 4. Press the OK button again when the desired selection appears in the audio display. 5. Press the OK button or dial button to call the selection.

Accessing Features Through the Cell Phone Menu

You can access your call history, phonebook, sent text messages as well as access cell phone and system settings. You can also access advanced features such as emergency assistance.

The system attempts to automatically re-download your phonebook and call history each time your cell phone connects to the system. You must turn on the auto download feature if your cell phone supports it.

Note: *This is a cell phone dependent feature.*

1. Press the **PHONE** button to enter the cell phone menu.

2. Select one of the options available.

Menu Item	Action and Description
Dial a number	Dial a number using the audio system numeric keypad.
Redial	Redial the last number called (if available). Press the OK button to select.
Phonebook	<p>Access your downloaded phonebook.</p> <ol style="list-style-type: none"> 1. Press the OK button to confirm and enter. You can use the options at the bottom of the screen to quickly access an alphabetical category. You can also use the letters on the keypad to jump in the list. 2. Scroll through your phonebook contacts. 3. Press the OK button again when the desired selection appears in the audio display. 4. Press the OK button or dial button to call the selection.
Call history	<p>Access any previously dialed, received or missed calls.</p> <ol style="list-style-type: none"> 1. Press the OK button to select. 2. Scroll to select either incoming calls, outgoing calls or missed calls. Press the OK button to make your selection. 3. Press the OK button or dial button to call the selection.
Speed Dial	Select one of 10 speed dial entries. To set a speed dial entry, go to the phonebook and press and hold one of the numbers on the audio system numeric keypad.
Text messaging	Send, download and delete text messages.
BT Devices	Access the following option for Bluetooth device menu listings:
	Add
	Delete
	Conn.
	Discon.
	Master
Phone settings	View various settings and features on your cell phone.

Text Messaging

WARNING



Local laws may prohibit some or all of the text messaging functions while driving. Check your local road rules before using these functions.

The system allows you to receive, send, download and delete text messages. The system can also read incoming text messages to you so that you do not have to take your eyes off the road.

Note: *This is a cell phone dependent feature.*

Receiving a Text Message

Note: *This is a phone-dependent feature. Your phone must support downloading text messages using Bluetooth to receive incoming text messages.*

Note: *This is a speed-dependent feature and is only available when your vehicle is traveling at 5 km/h or less.*

When a new message arrives, an audible tone sounds and the audio display indicates you have a new message.

To hear the message you can say:

Voice command	Action and Description
(listen to read) ([text] message)	Select this option to have the system read the message to you.

Using the screen you also have the following options:

Menu Item	Action and Description	
Ignore	Select this option, or do nothing, and the message goes into your text message inbox.	
View	Select the view option to open the text message. Once selected, you have the ability to have the message read to you, to view other messages. For additional options select:	
	More...	If you select this option, use the arrow button to scroll through the following options:
	Reply to sender	Press the OK button to access, and then scroll through a list of pre-defined messages to send.
	Call sender	Press the OK button to call the sender of the message.
	Forward msg.	Press the OK button to forward the message to anyone in your phonebook or call history. You can also choose to enter a number.

Sending, Downloading and Deleting Your Text Messages

1. Press the **PHONE** button.

2. Select the text messaging option, then press the **OK** button.

Choose from the following:

Menu Item	Action and Description
New	When you select the option to send a text message, a list of pre-defined messages appear in the audio display. Allows you to send a new text message based on a pre-defined set of 15 messages.
View	Allows you to read the full message and in addition provides the option to have the message read out to you by the system. To go to the next message select the more option. This allows you to reply to the sender, call the sender or forward the message.
Delete	Allows you to delete current text messages from the system (not your cell phone). The audio display indicates when all your text messages have been deleted.
More...	Allows you to delete all messages or to manually trigger a download of all unread messages from your cell phone.

Sending a Text Message

1. Select the send option when the desired selection is highlighted in the audio display.
2. Select the confirmation option when the contact appears and press the **OK** button again to confirm when the system asks if you would like to send the message. Each text message is sent with a pre-defined signature.

Note: *You can send text messages two ways. You can chose a contact from your phonebook, call history or by entering a phone number and selecting the text option from the audio display. You can also reply to a received message in the inbox.*

Note: *Only one recipient is allowed per text message.*

Accessing Your Cell Phone Settings

These are cell phone dependent features. Your cell phone settings allow you to access and adjust features such as your ringtone, text message notification, modify your phonebook and set up automatic download.

1. Press the **PHONE** button.
2. Scroll until the phone settings option appears, then press the **OK** button.
3. Scroll to select from the following options:

Menu Item	Action and Description
Set as master	If this option is checked, the system will use this cell phone as the master when there is more than one cell phone paired to the system. This option can be changed for all paired cell phones (not only for the active one) using the Bluetooth devices menu.
Phone status	See the cell phone name, provider name, cell phone number, signal level and battery level. When done, press the left arrow button to return to the cell phone status menu.
Set ringtone	<p>Select which ringtone sounds during an incoming call (one of the system's or your cell phone's). If your cell phone supports in-band ringing, your cell phone's ringtone sounds when you choose the cell phone ringtone option.</p> <ol style="list-style-type: none"> 1. Press the OK button to select and scroll to hear each ringtone. 2. Press the OK button to select.
Text msg notify	Have the option of hearing an audible tone to notify you when a text message arrives. Press the OK button to turn the audible tone on or off.
Phonebook pref.	Modify the contents of your phonebook, e.g. add, delete, download. Press the OK button to select and scroll between the options in the table below.

To modify the phone book preferences, choose from the following:

Menu Item	Action and Description
Add contacts	Push the desired contacts on your cell phone. Refer to your device's manual on how to push contacts. Press the OK button to add more contacts from your phonebook.
Delete	When a message asking you to delete appears, select the option to confirm. Press the OK button to delete the current phonebook and call history. The system takes you back to the menu for phone settings.
Download now	Press the OK button to select and download your phonebook to the system.
Auto-download	When automatic download is switched on, any changes, additions or deletions saved in the system since your last download are deleted. When automatic download is switched off, your phonebook will not be downloaded when your cell phone connects to the system. Your phonebook, call history and text messages can only be accessed when your paired cell phone is connected to the system. Check or uncheck this option to automatically download your phonebook each time your cell phone connects to the system. Downloading times are cell phone dependent and quantity dependent.

Bluetooth Devices

This menu provides access to your Bluetooth devices. Use the arrow buttons to scroll through the menu options. It allows you to add, connect and delete devices and set a cell phone as primary.

Bluetooth Devices Menu Options

1. Press the **PHONE** button.
2. Scroll until the Bluetooth device option appears, then press the **OK** button.
3. Scroll to select from the following options:

Menu Item	Action and Description
Add	Pair additional cell phones to the system. <ol style="list-style-type: none"> 1. Select the option to add to start the pairing process. 2. When a message to begin pairing appears in the audio display, search for SYNC on your cell phone. Refer to your device's manual if necessary. 3. Select SYNC on your cell phone.

Menu Item	Action and Description
	<ol style="list-style-type: none"> 4. Wait until the PIN appears on the phone display. Compare the PIN on the phone with the PIN shown in the audio display and accept the request on the phones and the vehicles display. The display indicates when the pairing is successful.* 5. When the option to set the cell phone as the primary cell phone appears, select either yes or no. 6. Depending on the functionality of your cell phone, the system may ask you extra questions (for example, if you would like to download your phonebook). Select either yes or no to confirm your response.
Delete	After deleting a cell phone from the list, the cell phone can only be connected again by repeating the full pairing process. Select the delete option and confirm when the system asks to delete the selected device.
Master	The system attempts to connect with the primary cell phone every time you switch the ignition on. When a cell phone is selected as primary, it appears first in the list and is marked with an asterisk. Set a previously paired cell phone as your primary cell phone. Select the master option to confirm the primary cell phone.
Conn.	Connect a previously paired cell phone. You can only have one cell phone connected at a time to use the cell phone functionality. When another cell phone is connected, the previous cell phone will be disconnected from the telephone services. The system allows you to use different Bluetooth devices for the cell phone functionality and the Bluetooth audio music playback feature at the same time.
Discon.	Disconnects the selected cell phone. Select this option and confirm when asked to. After disconnecting a cell phone, it can be connected again without repeating the full pairing process.

*In some cases the phone will request to enter a PIN. Enter the six-digit PIN provided by the system in the audio display. The display indicates when the pairing is successful.

System Settings

1. Press the **MENU** button.
2. Select the SYNC settings option, then press the **OK** button.
3. Scroll to select from the following options:

Menu Item	Action and Description
Bluetooth on	Check or uncheck this option to turn the Bluetooth interface of the system on or off. Select this option then press the OK button to change the option's status.
Set defaults	This selection does not erase your indexed information (phonebook, call history, text messages and paired devices). Select this option and confirm when prompted in the audio display. Return to the factory default settings.
Master reset	Completely erase all information stored on the system (phonebook, call history, text messages and paired devices) and return to the factory default settings. Select this option and confirm when prompted in the audio display. The display indicates when complete and the system takes you back to the previous menu.
Install on SYNC	Install applications or software updates you have downloaded. Select this option and confirm when prompted in the audio display. There must be a valid SYNC application or update available on the USB thumb drive in order to finish an installation successfully.
System info	Display the system's version numbers as well as its serial number. Press the OK button to select.
Voice settings	The voice settings submenu contains various options. See Using Voice Recognition (page 249).
Browse USB	Browse the actual menu structure of the connected USB device. Press the OK button and use the up or down arrows to scroll through the folders and files. Use the left or right arrows to enter and leave a folder. Media content can be directly selected for playback from this menu.

Press the **MENU** button to enter the system menu.

SYNC™ APPLICATIONS AND SERVICES

A list of available applications appears. Each application may have its own specific settings.

Message	Description and Action
SYNC-Apps	Scroll to this option, and then press OK .

SYNC Emergency Assistance

WARNINGS



For this feature to work, your cell phone must have Bluetooth and be compatible with the system.



Always place your cell phone in a secure location inside your vehicle. Failure to do so may cause serious injury to someone or damage the cell phone which could prevent this feature from working correctly.



Unless the feature setting is switched on prior to a crash, the system will not attempt to place an emergency call which could delay the response time, potentially increasing the risk of serious injury or death. Do not wait for the system to make an emergency call if you can do it yourself. Dial emergency services immediately to avoid a delayed response time. If you do not hear Emergency Assistance within five seconds of the crash, the system or cell phone may be damaged or non-functional.

If a crash deploys an airbag or triggers the fuel pump shut off, the system may contact emergency services through a paired and connected cell phone. For more information about the system and Emergency Assistance, visit the regional Ford website.

Note: *Before selecting this feature, you must read the Emergency Assistance privacy notice later in this section for important information.*

Note: *When you switch this feature on or off, that setting applies for all paired cell phones. If you have turned this feature off and a previously paired phone connects when you switch on the ignition, either a voice message plays, a display message or icon is shown, or both.*

Note: *Every cell phone operates differently. While this feature works with most cell phones, some cell phones may experience difficulties using this feature.*

Note: *Make sure you are familiar with the information about airbag deployment. See **Supplementary Restraints System** (page 24).*

Switching Emergency Assistance On and Off

Press the **MENU** button then select:

Message	Action
SYNC-Apps	Press OK .
Emerg. assist	Press OK . Select the option you require and press OK .

Display Options

If you switch on this feature, a confirmation message appears in the display.

If you switch off this feature, a dialog will appear in the display, which allows you to set a voice reminder.

Off with voice reminder provides a display and voice reminder when your cell phone connects and your vehicle starts.

Off without voice reminder provides a display reminder only without a voice reminder when your cell phone connects.

To make sure that Emergency Assistance works correctly:

- The system must have power and be working correctly at the time of the crash and during feature activation and use.
- You must switch on the feature before a crash.
- You must have a cell phone connected to the system.
- In certain countries, it may be necessary to have a valid and registered SIM card with credit in order to place and maintain an emergency call.
- A connected cell phone must have the ability to make and maintain an outgoing call at the time of the crash.
- A connected cell phone must have adequate network coverage, battery power and signal strength.
- Your vehicle must have battery power.

Note: *This feature only works in countries or regions where SYNC Emergency Assistance can call the local emergency services. Visit the regional Ford website for details.*

In the Event of a Crash

Note: *Not every crash deploys an airbag or triggers the fuel pump shut off (which may turn on Emergency Assistance). However, if Emergency Assistance is triggered the system tries to contact the emergency services. If a connected cell phone sustains damage or loses connection to the system, it searches for and tries to connect to any available previously paired cell phone. The system attempts to make an emergency call.*

Before making a call:

- If you do not cancel the call and SYNC makes a successful call, an introductory message plays for the emergency operator. After this message, there is hands-free communication between your vehicle's occupants and the operator.
- The system provides a short time window (approximately 10 seconds) to cancel the call. If you do not cancel the call, the system attempts to make an emergency call.
- The system plays a message letting you know when it attempts to make an emergency call. You can cancel the call by selecting the relevant function button or by pressing the end call button on the steering wheel.

During a call:

- Emergency Assistance uses your vehicle GPS or cellular network information when available to determine the most appropriate language to use. It alerts the emergency operator of the crash and delivers the introductory message. This may include your vehicle GPS coordinates.
- The language the system uses to interact with the occupants of your vehicle may differ from the language used to deliver information to the emergency operator.
- After the delivery of the introductory message the voice line opens so that you can speak hands-free with the emergency operator.
- When the line is connected, you must be prepared to provide your name, phone number and location information immediately.

Note: *While the system provides information to the emergency operator, the system plays a message letting you know it is sending important information. It then lets you know when the line is open to start hands-free communication.*

Note: *During an Emergency Assistance call, an emergency priority screen appears which contains vehicle GPS coordinates when available.*

Note: *It is possible that GPS location information is not available at the time of the crash; in this case, Emergency Assistance will still attempt to place an emergency call.*

Note: *It is possible that the emergency services will not receive the GPS coordinates; in this case, hands-free communication with an emergency operator is available.*

Note: *The emergency operator may also receive information from the cellular network such as cell phone number, cell phone location and cell phone carrier name independent from SYNC Emergency Assistance.*

Emergency Assistance may not work if:

- Your cell phone or Emergency Assistance hardware sustains damage in the crash.
- The vehicle battery or the system has no power.
- A crash ejects your cell phone from your vehicle.
- You do not have a valid and registered SIM card with credit in your cell phone.
- You are in a country or region where the SYNC Emergency Assistance cannot place the call. Visit the regional Ford website for details.

Important Information about the Emergency Assistance Feature

Emergency Assistance does not currently call emergency services in some countries.

Visit the regional Ford website for the latest details.

Emergency Assistance Privacy Notice

When you switch on Emergency Assistance, it may disclose to emergency services that your vehicle has been in a crash involving the deployment of an airbag or activation of the fuel pump shut off. This feature has the capability to disclose your location information to the emergency operator or other details about your vehicle or crash to provide the most appropriate emergency services.

If you do not want to disclose this information, do not switch on the feature.

SYNC AppLink

The system enables voice and manual control of SYNC AppLink enabled smartphone apps. Once an app is running through AppLink, you can control main features of the app through voice commands and manual controls.

Note: You must pair and connect your smartphone to SYNC to access AppLink.

Note: iPhone users need to connect the phone to the USB port.

Note: Android users need to connect the phone to SYNC using Bluetooth.

Note: For information on available apps, supported smartphone devices and troubleshooting tips please visit the Ford website.

Note: Make sure you have an active account for the app that you have downloaded. Some apps will work automatically with no setup. Other apps will want you to configure your personal settings and personalize your experience by creating stations or favorites. We recommend you do this at home or outside of your vehicle.

To Access Using the SYNC Menu

Scroll through the list of available applications and press **OK** to select an app. Once an app is running through SYNC, press the right arrow button to access the app menu. You can access various app features from here, for example thumbs up and thumbs down. Press the left arrow button to exit the app menu.

Press the **MENU** button then select:

Message	Description and Action
SYNC-Apps	
Mobile Apps	Scroll to this option, and then press OK .
Find new Apps	Select this option if the app required is not listed.

Note: If a SYNC AppLink compatible app cannot be found, make sure the required app is running on the mobile device.

To Access Using Voice Commands

Press the voice button and when prompted say:

Command	Description and Action
mobile (apps applications)	Say the name of the application after the tone. The application will start. While an app is running through SYNC, you can press the voice button and speak commands specific to the app.

The following voice commands are always available:

Command	Description and Action
[main menu] help	Use this command to hear a list of available voice commands.
mobile (apps applications)	The system will prompt you to say the name of the app to start it.
list [mobile] (apps applications)	The system will list all of the currently available mobile apps.
find [new] [mobile] (apps applications)	The system will search your connected mobile device for SYNC compatible apps.
(quit exit close)	Use this command followed by the name of the app.

You can also say the name of any SYNC compatible app to start it on SYNC. To see a list of the available voice commands for an app, say the name of an app followed by help. For example you could say "Spotify help".

Enabling and Disabling Push Notifications

Some apps can send push notifications. A push notification is an alert from an app running in the background and is delivered by voice, pop up or both. This may be particularly useful for news or location based apps.

Press the **MENU** button then select:

Message	Description and Action
SYNC-Apps	
Mobile Apps	
SYNC-Settings	
All Apps	If push notifications are supported, this setting will be listed. Select to enable or disable the feature as required.

Enabling SYNC Mobile Apps

To use the system you must consent to send and receive app authorization information and updates, using the data plan associated with the connected device.

Data is sent to Ford in the United States through the connected device. The information is encrypted and includes your VIN, SYNC module number, anonymous usage statistics and debugging information. Updates may take place automatically.

Note: *You must enable mobile apps for each connected device the first time you select a mobile app using the system.*

Note: Standard data rates will apply. Ford is not responsible for any additional charges you may receive from your service provider, when your vehicle sends or receives data through the connected device. This includes any additional charges incurred due to driving in areas when roaming out of a home network.

App Status

You can view the current status of an app in the settings menu. There are three possible statuses:

Message	Description and Action
Update needed	The system has detected a new app requiring authorization or a general permissions update is required.
Up-to-date	No update is required.
Updating...	The system is trying to receive an update.

Options in the settings menu:

Message	Description and Action
Request Update	If an update is required and you want to manually request the update, for example when you are in a Wi-Fi hotspot.
Disable Updates	Select this option to disable automatic updates.

App Permissions

Permissions are divided by groups. You can grant these group permissions individually. You can change a permission group status any time when not driving, by using the settings menu.

When you launch an app using SYNC, the system may ask you to grant certain permissions, for example:

- To allow your vehicle to provide vehicle information to the app including, but not limited to: Fuel level, fuel consumption, engine speed, battery voltage, odometer, VIN, external temperature, gear position, tire pressure, ambient temperature, date and time.
- To allow your vehicle to provide driving characteristic information, including, but not limited to: MyKey, seatbelt status, engine speeds, braking events, brake pedal switch, acceleration, accelerator pedal position, clutch pedal switch, trip length, trip time, trip cost, percent engine on time, and percent of time at speed.

- To allow your vehicle to provide location information, including: GPS and speed.
- To allow the app to send push notifications using the vehicle display and voice capabilities while running in a background state.

Note: You will only need to grant permissions the first time you use an app with SYNC.

Note: We are not responsible or liable for any damages or loss of privacy relating to usage of an app, or dissemination of any vehicle data that you approve us to provide to an app.

USING SYNC™ WITH YOUR MEDIA PLAYER

You can access and play music from your media player through your vehicle's speaker system using the system's media menu or voice commands. You can also sort and play your music by specific categories, for example artist or albums.

SYNC is capable of hosting nearly any media player including: iPod, Zune, Plays from device players, and most USB drives. SYNC also supports audio formats, for example MP3, WMA, WAV and ACC.

Voice Command	Description and Action
(USB [stick] iPod MP3 [player])	You can now play music by saying any of the appropriate voice commands. Refer to the media voice commands.

Words in brackets [] are optional and do not have to be spoken for the system to understand the command. For example, for where (USB [stick] | iPod | MP3 [player]) appears, you can say USB or USB stick.

To Connect Using the System Menu

1. Plug the device into your vehicle's USB port.

Confirm that the USB device has been formatted correctly and has the following specifications:

- USB 2.0.
- File format must be FAT16/32.

Note: NTFS file format is not supported.

The format of the audio files on the USB device must be:

- MP3.
- Non DRM protected WMA.
- WAV.
- AAC.

Connecting Your Media Player to the USB Port

Note: If your media player has a power switch, make sure you switch on the device.

To Connect Using Voice Commands

1. Plug the device into your vehicle's USB port.
2. Press the voice button and when prompted say:

2. Press the **Media** button (next to the audio display) until an initializing message appears in the display.

Message	Description and Action
Browse USB	Depending on how many media files are on your connected device, an indexing message may appear in the display. When indexing is complete, the screen returns to the playback menu.

Choose from the following:

Message
Play all
Playlists
Songs
Artists
Albums
Genres
Browse USB
Reset USB
Exit

What's Playing?

At any time during playback, you can press the voice button and ask the system what is playing. The system reads the metadata tags of the current track, if populated.

Media Voice Commands



Press the voice button and when prompted say:

Voice Command	Description and Action
(USB [stick] iPod MP3 [player])	You can now play music by saying any of the appropriate voice commands.

You can say any of the voice commands that appear within open and close brackets that are separated by |. For example, where; (what's | what is) appears you say; what's or what is.

You must say any of the voice commands that appear outside of open and close brackets. For example, where; who plays this (what's | what is) playing, you must say; who plays this (what's or what is) playing.

Then any of the following:

Voice Command	
play	
pause	
play all	
play [artist]	*
play [album]	*
play [genre]	*
[play] next track	
play [playlist]	*
[play] previous track	
play [song track title file]	*
Repeat Off	
repeat one [on]	
(browse search show) album	
(browse search show) artist	
(browse search show) genre	
(browse search show) playlist	
(browse search show) all (album albums)	
(browse search show) all (artist artists)	
(browse search show) all (genre genres)	
(browse search show) all (playlist playlists)	
(browse search show) all (song songs title titles file files track tracks)	
shuffle [all] [on]	
shuffle off	

SYNC™

Voice Command
Similar Music
((who's who is) this who plays this (what's what is) playing [now] (what which) (song track artist) is this (who's who is) playing (what's what is) this)

* This voice command is not available until indexing is complete.

Voice Command Guide

Voice Command	Description and Action
(browse search show) genre	The system searches all the data from your indexed music and if available, begins to play the chosen type of music.
[play] (similar music more like this)	The system compiles a playlist and then plays similar music to what is currently playing from the USB port using indexed metadata information.
(browse search show) artist	The system searches for a specific artist, track or album from the music indexed through the USB port.
(browse search show) album	The system searches for a specific artist, track or album from the music indexed through the USB port.

The system is also capable of playing music from your cell phone through Bluetooth.

To switch the Bluetooth audio on, use the **MEDIA** button (next to the audio display) or **Source** button, or press the voice button and when prompted say:

Voice Command	Description and Action
Bluetooth Audio	

Then any of the following:

Voice Command	Description and Action
pause	
play	
[play] next track	
[play] previous track	

Media Menu Features

The media menu allows you to select how to play your music, for example by artist,

genre, shuffle or repeat, and to find similar music or reset the index of your USB devices.

Press **AUX** to select USB playback.

Message	Description and Action
Options	This will enter the media menu.

Then any of the following:

Message	Description and Action
Shuffle	Choose to shuffle or repeat your music. Once you make your choice, it remains on until you switch it off.
Repeat track	Choose to shuffle or repeat your music. Once you make your choice, it remains on until you switch it off.
Similar music	You can play similar types of music to the current playlist from the USB port. The system uses the metadata information of each track to compile a playlist. The system then creates a new list of similar tracks and then begins playing. Each track must have the metadata tags populated for this feature. With certain playing devices, if your metadata tags are not populated, the tracks will not be available in voice recognition, the play menu or this option. However, if you place these tracks onto your playing device in mass storage device mode they are available in voice recognition, the play menu or this option. The system places unknowns into any unpopulated metadata tag.
Reset SYNC USB	Resets the USB index. After the new indexing is complete you can choose what to play from the USB song library.

Accessing Your USB Song Library

1. Plug the device into your vehicle's USB port.

2. Press **MEDIA** button (next to the audio display) to select USB playback.

Message	Description and Action
Browse USB	This menu allows you to select and play your media files by artist, album, genre, playlist and track or even to browse what is on your USB device.

SYNC™

If there are no media files to access, the display indicates there is no media. If there

are media files, you have the following options to scroll through and select:

Message	Description and Action
Play all	Play all indexed media files from your playing device one at a time in numerical order.* 1. Press OK to select. The first track title appears in the display.
Playlists	Access your playlists from formats, ASX, M3U, WPL or MTP.* 1. Press OK to select. 2. Scroll to select the desired playlist, and then press OK .
Songs	Search for and play a specific indexed track.* 1. Press OK to select. 2. Scroll to select the desired track, and then press OK .
Artists	Sort all indexed media files by artist. Once selected, the system lists and then plays all artists and tracks alphabetically.* 1. Press OK to select. 2. Scroll to select the desired artist, and then press OK .
Albums	Sort all indexed media files by albums.* 1. Press OK to select. 2. Scroll to select the desired albums, and then press OK .
Genres	Sort indexed music by genre type.* 1. Press OK to select. 2. Scroll to select the desired genre, and then press OK .

Message	Description and Action
Browse USB	Browse all supported media files on your media player connected to the USB port. You can only view media files that are compatible with SYNC; other saved files are not visible. <ol style="list-style-type: none"> 1. Press OK to select. 2. Scroll to browse indexed media files on your flash drive, and then press OK.
Reset USB	Resets the USB index. After the new indexing is complete, you can choose what to play from the USB song library.

* You can use the buttons at the bottom of the audio display to jump to a certain alphabetical category quickly. You can also use the letters on the numeric keypad to jump in the list.

Bluetooth Devices and System Settings

You can access these menus using the audio display. See **Using SYNC™ With Your Media Player** (page 270).

SYNC™ TROUBLESHOOTING

Your SYNC system is easy to use. However, should questions arise, please refer to the tables below.

To check your cell phone's compatibility, visit the regional Ford website.

Cell phone issues		
Issue	Possible cause	Possible solution
A lot of back-ground noise during a phone call.	The audio control settings on your cell phone may be affecting SYNC performance.	Refer to your device's manual about audio adjustments.
During a call, I can hear the other person but they cannot hear me.	Possible cell phone malfunction.	Try switching off your cell phone, resetting it or removing the battery, then trying again.
		Make sure that the microphone for SYNC is not set to off.
SYNC is not able to download my phone-book.	This is a cell phone-dependent feature.	Check your cell phone's compatibility.
	Possible cell phone malfunction.	Try switching off your cell phone, resetting it or removing the battery, then trying again.

SYNC™

Cell phone issues		
Issue	Possible cause	Possible solution
		Try pushing your phonebook contacts to SYNC by selecting the option to add.
		You must switch on your cell phone and the automatic phonebook download feature on SYNC.
The system says "Phonebook downloaded" but my SYNC phonebook is empty or is missing contacts.	Limitations on your cell phone's capability.	Try pushing your phonebook contacts to SYNC by selecting the option to add.
		If the missing contacts are stored on your SIM card, try moving them to your cell phone's memory.
		Remove any pictures or special ring tones associated with the missing contact.
		You must switch on your cell phone and the automatic phonebook download feature on SYNC.
I am having trouble connecting my cell phone to SYNC.	This is a cell phone-dependent feature.	Check your cell phone's compatibility.
	Possible cell phone malfunction.	Try switching off your cell phone, resetting it or removing the battery, then trying again.
		Try deleting your device from SYNC and deleting SYNC from your device, then trying again.
		Always check the security and auto accept prompt settings relative to the SYNC Bluetooth connection on your cell phone.
		Update your cell phone's firmware.
		Switch off the auto download setting.
Text messaging is not working on SYNC.	This is a cell phone-dependent feature.	Check your cell phone's compatibility.
	Possible cell phone malfunction.	Try switching off your cell phone, resetting it or removing the battery, then trying again.
	iPhone	<ul style="list-style-type: none"> • Go to your cell phone's Settings. • Go to the Bluetooth Menu.

SYNC™

Cell phone issues		
Issue	Possible cause	Possible solution
		<ul style="list-style-type: none"> • Make sure the connection status shows Not Connected. • Press the blue circle to enter the next menu. • Turn on Show Notifications. • Turn on Sync Contacts. <p>Your iPhone is now set up to forward incoming text messages to SYNC. Repeat these steps for every other Sync vehicle you are connected to. Your iPhone will only forward incoming text messages to SYNC if it is unlocked. Replying to text messages using SYNC is not supported by iPhone. Text messages from WhatsApp and Facebook Messenger are not supported.</p>
Audible text messages do not work on my cell phone.	This is a cell phone-dependent feature.	<p>Your cell phone must support downloading text messages through Bluetooth to receive incoming text messages.</p> <p>Access the text messaging menu of SYNC to see if your cell phone supports the feature. Press the PHONE button and then scroll and select the option for text messaging, then press OK.</p>
	This is a cell phone limitation.	<p>Because each cell phone is different, refer to your device's manual for the specific cell phone you are pairing. In fact, there can be differences between cell phones due to brand, model, service provider and software version.</p>

SYNC™

USB and media issues		
Issue	Possible cause	Possible solution
I am having trouble connecting my device.	Possible device malfunction.	Try switching off the device, resetting it or removing the battery, then trying again.
		Make sure you are using the manufacturer's cable.
		Make sure you correctly insert the USB cable in to the device and your vehicle's USB port.
		Make sure that the device does not have an auto-install program or active security settings.
SYNC does not recognize my device when I start my vehicle.	This is a device limitation.	Make sure you are not leaving the device in your vehicle during very hot or cold temperatures.
Bluetooth audio does not stream.	This is a device-dependent feature.	Make sure you connect the device to SYNC and press play on your device.
	The device is not connected.	
SYNC does not recognize music that is on my device.	Your music files may not contain the correct artist, song title, album or genre information.	Make sure that all song details are populated.
	The file may be corrupted.	Try replacing the corrupt file with a new version.
	The song may have copyright protection that does not allow it to play.	Some devices require you to change the USB settings from mass storage to media transfer protocol class.

SYNC™

USB and media issues		
Issue	Possible cause	Possible solution
When I connect my iPhone or iPod Touch through the USB and Bluetooth Audio at the same time, I sometimes do not hear any sound.	This is a device limitation.	From the iPhone or iPod Touch music now playing screen, select the audio device airplay icon at the very bottom of your iPhone or iPod Touch screen.
		To listen to the iPhone or iPod Touch through Bluetooth Audio, select SYNC.
		To listen to the iPhone or iPod Touch through USB, select Dock Connector.

Voice command issues		
Issue	Possible cause	Possible solution
SYNC does not understand what I am saying.	You may be using the wrong voice commands.	Review the cell phone voice commands and the media voice commands at the beginning of their respective sections.
		Refer to the audio display during an active voice session to find a list of voice commands there.
	You may be speaking too soon or at the wrong time.	The microphone for the system is either in your rear view mirror or in the headliner just above the windshield.
SYNC does not understand the name of a song or artist.	You may be using the wrong voice commands.	Review the media voice commands at the beginning of the media section.
	You may not be saying the name exactly as the system saved it.	Say the song or artist exactly as the system saved it. If you say, "Play Artist Prince", the system does not play music by Prince and the Revolution or Prince and the New Power Generation.
		Make sure you are saying the complete title such as "California remix featuring Jennifer Nettles".
		If the song titles are in capital letters, you have to spell them. LOLA requires you to say "L-O-L-A".

SYNC™

Voice command issues		
Issue	Possible cause	Possible solution
	The system may not be reading the name the same way you are saying it.	Do not use special characters in the title, as the system does not recognize them.
SYNC does not understand or is calling the wrong contact when I want to make a call.	You may be using the wrong voice commands.	Review the cell phone voice commands at the beginning of the cell phone section.
		You can also use the cell phone and media suggestion lists to get a list of possible suggestions when the system cannot fully understand you. See Using Voice Recognition (page 249).
	You may not be saying the name exactly as the system saved it.	Make sure you are saying the name exactly as the system saved it. For example, if the contact name is Joe Wilson, say "Call Joe Wilson".
		The system works better if you list full names such as "Joe Wilson" rather than "Joe".
	Contacts in your phonebook may be very short and similar or they may contain special characters.	Do not use special characters such as 123 or ICE as the system does not recognize them.
Your phonebook contacts may be in capital letters.	If the contacts are in capital letters, you have to spell them. JAKE requires you to say "Call J-A-K-E".	
The SYNC voice control system is having trouble recognizing foreign names stored on my cell phone.	You may be saying the foreign names using the currently selected language for SYNC.	SYNC applies the phonetic pronunciation rules of the selected language to the contact names stored on your cell phone.
		Helpful Hint: You can select your contact manually. Press PHONE . Select the option for phonebook and then contact name. Press the soft-key option to hear it. SYNC will read the contact name to you, giving you some idea of the pronunciation it is expecting.

Voice command issues		
Issue	Possible cause	Possible solution
The SYNC voice control system is having trouble recognizing foreign tracks, artists, albums, genres and playlist names from my media player or USB flash drive.	You may be saying the foreign names using the currently selected language for SYNC.	SYNC applies the phonetic pronunciation rules of the selected language to the names stored on your media player or USB flash drive. It is able to make some exceptions for very popular artist names (for example, U2) such that you can always use the English pronunciation for these artists.
The system generates voice prompts and the pronunciation of some words may not be accurate for my language.	SYNC uses text-to-speech voice prompt technology.	SYNC uses a synthetically generated voice rather than pre-recorded human voice.
		SYNC offers several new voice control features for a wide range of languages. Dialing a contact name directly from the phonebook without pre-recording (for example, "call John Smith") or selecting a track, artist, album, genre or playlist directly from your media player (for example, "play artist Madonna").
My previous Bluetooth voice control system allowed me to control the radio, CD, and climate control systems. Why can I not control these systems with SYNC?	The focus of SYNC is to control your mobile devices and the content stored on them.	SYNC offers significant capability beyond the previous system such as dialing a contact name directly from the phonebook without pre-recording (for example, "call John Smith") or selecting a track, artist, album, genre or playlist directly from your media player (for example, "play artist Madonna").

General		
Issue	Possible cause	Possible solution
<p>The language selected for the instrument cluster and information and entertainment display does not match the SYNC language (phone, USB, Bluetooth audio, voice control and voice prompts).</p>	<p>SYNC does not support the currently selected language for the instrument cluster and information and entertainment display.</p>	<p>SYNC only supports four languages in a single module for text display, voice control and voice prompts. The country where you bought your vehicle dictates the four languages based on the most popular languages spoken. If the selected language is not available, SYNC remains in the current active language.</p>
		<p>SYNC offers several new voice control features for a wide range of languages. Dialing a contact name directly from the phonebook without pre-recording (for example, "call John Smith") or selecting a track, artist, album, genre or playlist directly from your media player (for example, "play artist Madonna").</p>

AppLink issues		
Issue	Possible cause(s)	Possible solution(s)
AppLink Mobile Applications: When I select "Find New Apps", SYNC does not find any applications.	An AppLink capable phone is not connected to SYNC.	Ensure you have a compatible smartphone; an Android with OS 2.3 or higher or an iPhone 3GS or newer with iOS 5.0 or higher. Additionally, ensure your phone is paired and connected to SYNC in order to find AppLink-capable apps on your device. iPhone users must also connect to SYNC's USB port with an Apple USB cable.
My phone is connected, but I still cannot find any apps.	AppLink-enabled apps are not installed and running on your mobile device.	Ensure you have downloaded and installed the latest version of the app from your phone's app store. Ensure the app is running on your phone. Some apps require you to register or login on the app on the phone before using them with AppLink. Also, some may have a "Ford SYNC" setting, so check the app's settings menu on the phone.
My phone is connected, my app(s) are running, but I still cannot find any apps.	Sometime apps do not properly close and re-open their connection to SYNC, over ignition cycles, for example.	Closing and restarting apps may help SYNC find the application if you cannot discover it inside the vehicle. On an Android device, if apps have an 'Exit' or 'Quit' option, select that and then restart the app. If the app does not have that option, you can also manually "Force Close" the app by going to the phone's settings menu, selecting 'Apps.' then finding the particular app and choosing 'Force stop'. Don't forget to restart the app afterwards, then select "Find New Apps" on SYNC.
		On an iPhone with iOS7+, to force close an app, double tap the home button then swipe up on the app to close it. Tap the home button again, then select the app again to restart it. After a few seconds, the app should then appear in SYNC's Mobile App's Menu.

SYNC™

AppLink issues		
Issue	Possible cause(s)	Possible solution(s)
My Android phone is connected, my app(s) are running, I restarted them, but I still cannot find any apps.	There is a Bluetooth bug on some older versions of the Android OS that may cause apps that were found on your previous vehicle drive to not be found again if you have not turned off Bluetooth.	Reset the Bluetooth on your phone by turning it off and then turning Bluetooth back on. If you are in your vehicle, SYNC should be able to automatically re-connect to your phone if you press the "Phone" button.
My iPhone is connected, my app is running, I restarted the app but I still cannot find it on SYNC.	The USB connection to SYNC may need to be reset.	Unplug the USB cable from the phone, wait a moment, and plug the USB cable back in to the phone. After a few seconds, the app should appear in SYNC's Mobile Apps Menu. If not, "Force Close" the application and restart it.
I have an Android phone. I found and started my media app on SYNC, but there is no sound or the sound is very low.	The Bluetooth volume on the phone may be low.	Try increasing the Bluetooth volume of the device by using the device's volume control buttons which are most often found on the side of the device.
I can only see some of the AppLink apps running on my phone listed in SYNC's Mobile Apps Menu.	Some Android devices have a limited number of Bluetooth ports apps can use to connect. If you have more AppLink apps on your phone than the number of available Bluetooth ports, you will not see all of your apps listed in SYNC's mobile apps menu.	Force close or uninstall the apps you do not want SYNC to find. If the app has a "Ford SYNC" setting, disable that setting in the app's settings menu on the phone.

SYNC™ 2

GENERAL INFORMATION

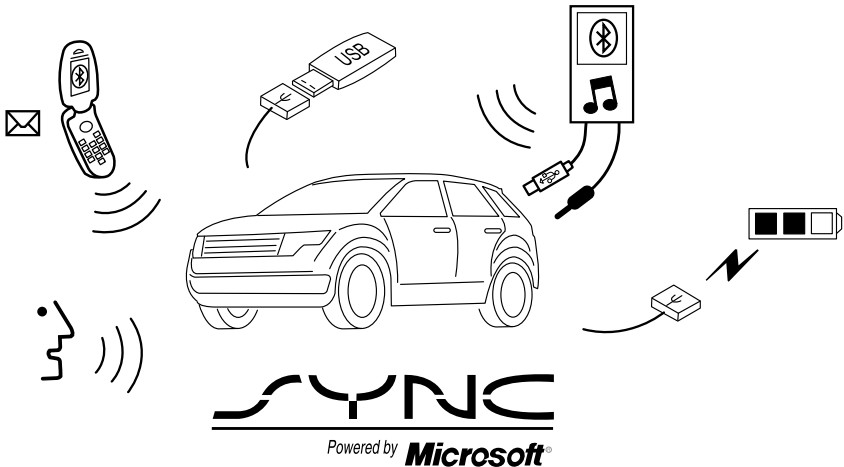

E142598

Note: *This manual describes product features and options available throughout the range, sometimes even before they are generally available. It may describe options not fitted to the vehicle you have purchased.*

SYNC 2 uses Bluetooth wireless technology to pass information between your vehicle and your phone. You can use voice commands and other simple controls, such as steering wheel buttons, to make and receive calls or listen to text messages. Whatever your phone can do, SYNC lets you do so you can keep your hands on the wheel and your eyes on the road.

Like a universal remote control, SYNC controls other systems besides your phone. SYNC connects you to:

- **Entertainment**, including AM/FM radio, DAB Radio (if equipped), or music on USB, SD Card, and other external devices
- **Navigation** assistance (if equipped), including maps
- **Information** such as traffic (if equipped), notification, calendar and more through SYNC Application and Services (if equipped)
- **Climate** controls
- **Settings**

SYNC™ 2

SYNC is customized in each vehicle, so the design is different, but the basics are the same. In vehicles with SYNC 2, the 8-inch touchscreen in the center console lets you view information and adjust Phone, Entertainment, Navigation (if equipped), and Climate settings.

Note: Make sure that you refer your device's user guide before using it with SYNC.

Note: Your SYNC system performs regular system maintenance in the background while you are not using the car.

WARNINGS

 Operating certain parts of this system while driving can distract your attention away from the road, and possibly cause an accident or other serious consequences. Do not change system settings or enter data non-verbally (using your hands) while driving. Stop the

WARNINGS

vehicle in a safe and legal manner before attempting these operations. This is important since while setting up or changing some functions you might be required to distract your attention away from the road and remove your hands from the wheel.



Driving while distracted can result in loss of vehicle control, crash and injury. We strongly recommend that you use extreme caution when using any device that may take your focus off the road. Your primary responsibility is the safe operation of your vehicle. We recommend against the use of any hand-held device while driving and encourage the use of voice-operated systems when possible. Make sure you are aware of all applicable local laws that may affect the use of electronic devices while driving.

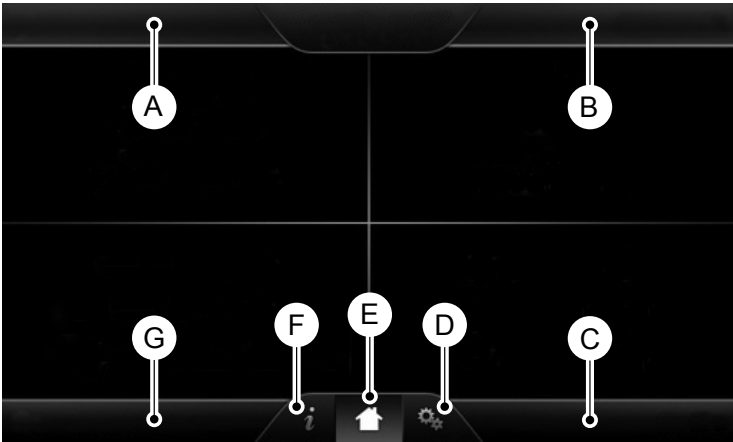

E161891

SYNC™ 2

Item	Message
A	Phone
B	Navigation
C	Climate
D	Settings
E	Home
F	Information
G	Entertainment

This system uses a four-corner strategy to provide quick access to several vehicle features and settings. The touchscreen provides easy interaction with your mobile phone, multimedia, climate control and navigation system. The corners display any active modes within those menus, such as phone status or the climate temperature.

Note: Some features are not available while your vehicle is moving.

Note: Your system is equipped with a feature that allows you to access and control audio features for 10 minutes after you switch the ignition off (and no doors open).

PHONE

Press to select any of the following:

Message
Phone
Speed dial
Phonebook
Call history
Messaging
Settings

NAVIGATION

Press to select any of the following:

Message
My Home
Favorites
Previous Destinations
Place of interest
Emergency
Address
Junction
Town centre
Map
Edit Route
Cancel Route

CLIMATE

Press the corresponding icons to control the following options:

- Driver Settings.
- Recirculated Air.
- Auto.
- Dual.
- Passenger Settings.
- A/C.
- Defrost.

SYNC™ 2

SETTINGS



Press to select any of the following:

Message
Clock
Display
Sound
Vehicle
Settings
Help

HOME



Press to access your home screen. Depending on your vehicle's option package and software, your screens may vary in appearance from the descriptions in this section. Your features may also be limited depending on your market. Check with an authorized dealer for availability.

INFORMATION



Press to select any of the following:

Message
Traffic
Notifications
Calendar
Apps
Where Am I?

ENTERTAINMENT

Press to select any of the following:

Message
AM
FM
DAB*
CD
USB
BT Stereo
SD Card
Line In

* If equipped.

Using the Audio Controls

Depending on your vehicle, it may also have the following controls:

Menu Item	Action and Description
Power	Switch the media features on or off.
Vol	Adjust the volume of playing media.
Seek	Use as you normally would in media modes.
Tune	Use as you normally would in media modes.
Eject	Eject CD from the entertainment system.
Display	Press this button to switch the display screen off. Press again, or touch the screen to switch the display screen on.
Source	Touch the control repeatedly to switch between media modes.
Sound	Adjust the settings for:
	Bass
	Treble
	Midrange
	Set Balance and Fade
	DSP
	Speed Compensated Volume

Using the Steering Wheel Controls

Depending on your vehicle and option package, you can use your steering wheel controls to interact with the touchscreen system.

- **VOL:** Control the volume of audio output.
- **Mute:** Mute the audio output.
- **Voice:** Press to start a voice session. Press again and hold to end a voice session.

- **SEEK and PHONE ACCEPT:**
 - While in radio mode, press to seek between memory presets or press and hold to seek between stations.
 - While in USB or CD mode, press to seek between tracks or press and hold to fast seek.
 - While in phone mode, press to answer a call, or to switch between calls.
- **SEEK and PHONE REJECT:**
 - While in radio mode, press to seek between memory presets or press and hold to seek between stations.
 - While in USB or CD mode, press to seek between tracks or press and hold to fast seek.
 - While in phone mode, press to end a call, or to reject an incoming call.

See **Steering Wheel** (page 41).

Cleaning the Touchscreen Display

Use a dry, clean, soft cloth. If dirt or fingerprints are still visible, apply a small amount of alcohol to the cloth. Do not pour or spray alcohol onto the display. Do not use detergent or any type of solvent to clean the display.

Support

For further support, contact an authorized dealer. For more information, visit the regional Ford website.

Safety Information

WARNING



Driving while distracted can result in loss of vehicle control, crash and injury. We strongly recommend that you use extreme caution when using any device that may take your focus off the road. Your primary responsibility is the safe operation of your vehicle. We recommend against the use of any hand-held device while driving and encourage the use of voice-operated systems when possible. Make sure you are aware of all applicable local laws that may affect the use of electronic devices while driving.

- Do not attempt to service or repair the system. Have an authorized dealer check your vehicle.
- Do not operate playing devices if the power cords or cables are broken, split or damaged. Place cords and cables out of the way, so they do not interfere with the operation of pedals, seats, compartments or safe driving abilities.
- Do not leave playing devices in your vehicle during extreme conditions as it could cause them damage. See your device's user guide for further information.
- For your safety, some SYNC functions are speed-dependent. Their use is limited to when your vehicle is traveling at speeds under 8 km/h.

Make sure that you review your device's manual before using it with SYNC.

Speed-restricted Features

Some features of this system may be too difficult to use while your vehicle is moving so they are restricted from use unless your vehicle is stationary.

See the following chart for more specific examples.

Restricted Features	
Settings	Editing settings while the rear view camera or active park assist are active.
Text Messages	Composing text messages.
	Editing preset text messages.
Navigation	Demo navigation route.

Privacy Information

When a mobile phone connects to SYNC, the system creates a profile that links to that mobile phone. The system creates the profile to offer you more mobile features and to operate more efficiently. Among other things, this profile may contain data about your phonebook, text messages (read and unread) and call history. This includes the history of calls when your mobile phone was not connected to the system. If you connect a media player, the system creates and retains an index of supported media content. The system also records a short development log of approximately 10 minutes of all recent system activity. Use the log profile and other system data to improve the system and help diagnose any problems that may occur.

The mobile phone profile, media player index and development log remain in the system unless deleted. They are generally accessible in your vehicle only when you connect your mobile phone or media player. If you no longer plan to use the system or your vehicle, we recommend you complete a master reset to erase all stored information. See **Information Displays** (page 67).

Special equipment is required to access system data. Access to your vehicle's SYNC module is also required. We will not access the system data for any purpose other than as described without consent. Examples where we can access system data are for a court order, where required by law enforcement, other government authorities or other third parties acting with lawful authority. Other parties may seek to access the information independently of us. Further privacy information is available.

Using Voice Recognition

This system helps you control many features using voice commands. This allows you to keep your hands on the wheel and focus on what is in front of you. The system provides feedback through audible tones, prompts, questions and spoken confirmations depending on the situation and the chosen level of interaction (voice settings).

The system also asks short questions (confirmation prompts) when it is not sure of your request or when there are multiple possible responses to your request.

When using voice commands, words and icons may appear in the lower left status bar indicating the status of the voice command session.

How to Use Voice Commands



The following are some of the voice commands that you can say at any time during a voice command session.

Press the voice button and when prompted say:

Voice command
main menu
What Can I Say
Previous Page
Go back
Help

Helpful Hints

- Make sure the interior of your vehicle is as quiet as possible. Wind noise from open windows and road vibrations may prevent the system from correctly recognizing spoken voice commands.
- After pressing the voice command icon, wait until after the tone sounds and a message appears before saying a voice command. Any voice command spoken prior to this does not register with the system.
- Speak naturally, without long pauses between words.
- At any time, you can interrupt the system while it is speaking by pressing the voice command icon.

Accessing a List of Available Voice Commands

To access a list of available voice commands you can do either of the following.

Using the touchscreen, press:

Menu Item
Settings
Help
Voice Command List

Using the steering wheel control, press the voice button and when prompted say one of the following:

Voice Commands
List of Commands
Radio List of Commands
Phone List of Commands
Voice Instructions List of Commands

Voice Command Settings

These allow you to customize the level of system interaction, help and feedback. The system defaults to standard interaction that uses candidate lists and confirmation prompts as these provide the highest level of guidance and feedback.

SYNC™ 2

Menu Item	Action and Description	
Interaction Mode	Novice	In this mode the system provides detailed interaction and guidance.
	Advanced	This mode has less audible interaction and more tone prompts.
Confirmation Prompts	The system uses these short questions to confirm your voice command. If turned off, the system simply makes a best guess as to what you requested. The system may still occasionally ask you to confirm a voice command.	
Phone Candidate Lists	Candidate lists are lists of possible results from your voice commands. The system creates these lists when it has the same confidence level of several options based on your voice command.	
Media Candidate Lists		

Using the touchscreen, press the settings icon, then press:

Menu Item
Voice settings
Voice Control
Select from the following:
Interaction Mode
Confirmation Prompts
Media Candidate Lists
Phone Candidate Lists
Voice Control Volume

Using Voice Commands with the Touchscreen Options

The voice command system has a dual mode feature which allows you to switch between using voice commands and making on-screen selections. This is available only when the system displays a list of candidates generated during a voice command session. For example, this can be used when entering a street address or trying to call a contact from a mobile phone paired to the system.

SETTINGS

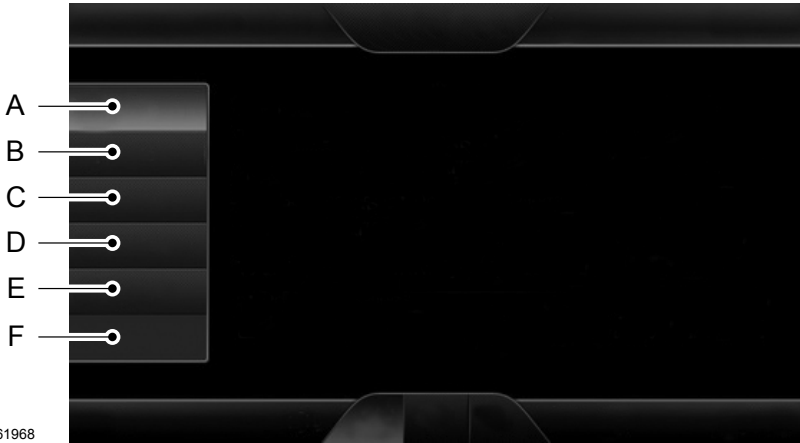

E161968

Item	Menu Item
A	Clock
B	Display
C	Sound
D	Vehicle
E	Settings
F	Help

Clock



Under this menu, you can set the clock, access and adjust the display, sound and vehicle settings as well as access settings for specific modes or the help feature.

SYNC™ 2

To make adjustments using the touchscreen, select:

Menu Item	Action and Description
Settings	Press the settings icon.
Clock	Press the + or - to adjust the time. From this screen, you can also make other adjustments such as 12-hour or 24-hour mode, activate GPS time synchronization and have the system automatically update new time zones. You can also switch the outside air temperature display off and on. It appears at the top center of the touchscreen, next to the time and date.

Note: You cannot manually set the date. Your vehicle's GPS does this for you.

Note: If the battery has been disconnected, your vehicle needs to acquire a GPS signal to update the clock. Once your vehicle acquires the signal, it may take a few minutes for the update to display the correct time.

Display



You can adjust the display using the touchscreen or the voice button on the steering wheel controls.

To make adjustments using the touchscreen, select:

Menu Item	Action and Description	
Settings	Press the settings icon.	
Display		
Then select from the following:		
Mode	Allows you to switch the display off. It also allows you to set the screen to a certain brightness or have the system automatically change based on the outside light level. If you also select:	
	Auto	These features will allow you to adjust the dimming of your screen.
	Night	
Edit Wallpaper	Allows you to display the default photo or upload your own.	

SYNC™ 2

Menu Item	Action and Description	
Auto Dim	When set to On , lets you use the automatic dimming feature. When set to Off you are able to adjust the brightness of the screen.	
	Brightness	Make the screen display brighter or dimmer.
Auto Dim Manual Offset	Allows you to adjust screen dimming as the outside lighting conditions change from day to night.	



You can adjust the display settings using the touchscreen or the voice button on the steering wheel controls.

To make adjustments using the voice button, press the button and when prompted, say:

Voice command
Display Settings

Uploading Photos for Your Home Screen Wallpaper

Note: You cannot load photos directly from your camera. You must access the photos either from your USB mass storage device or from an SD card.

To upload your photos, select:

Menu Item	Action and Description
Settings	Press the settings icon.
Display	
Edit Wallpaper	Follow the system prompts to upload your photographs.

Note: Photographs with extremely large dimensions (such as 2048 x 1536) may not be compatible and appear as a blank (black) image on the display.

The system allows you to upload and view up to 32 photos.



To access, press the settings button.

SYNC™ 2

Only the photograph(s), which meets the following conditions display:

- Compatible file formats are as follows: JPG, GIF, PNG, BMP.
- Each file must be 1.5 MB or less.

- Recommended dimensions: 800 x 384.

Sound



To make adjustments using the touchscreen, select:

Menu Item
Settings
Sound
Then select from the following:
Bass
Midrange
Treble
Set Balance and Fade
DSP occupancy
Adaptive volume

Note: *Your vehicle may not have all of these sound settings.*

Vehicle



To make adjustments using the touchscreen, select:

Menu Item
Settings
Vehicle
Then select from the following:
Ambient light
Camera Settings
Enable Valet Mode

SYNC™ 2

Ambient Lighting (If Equipped)

When you switch this feature on, ambient

lighting illuminates the footwells, media bin, door release handles, and the door map pockets with a choice of colors.

To make adjustments using the touchscreen, select:

Menu Item	Action and Description
Settings	Press the settings icon.
Vehicle	
Ambient light	

- You can then touch the desired color.
- Use the scroll bar to increase or decrease the intensity.
- To switch the feature on or off, press the power button.

Camera Settings



This menu allows you to access settings for your rear view camera.

To make adjustments using the touchscreen, select:

Menu Item	Action and Description
Settings	Press the settings icon.
Vehicle	
Camera Settings	

Then select from the following:

Enhanced Park Pilot	
Rear Camera Delay	

You can find more information on the rear view camera system in another chapter. See **Parking Aids** (page 138).

SYNC™ 2

Enable Valet Mode



Valet mode allows you to lock the system.

No information is accessible until the system is unlocked with the correct PIN.

Note: *If the system locks, and you need to reset the PIN, contact an authorized dealer.*

To make adjustments using the touchscreen, select:

Menu Item	Action and Description
Settings	Press the settings icon.
Vehicle	
Enable Valet Mode	Then enter a four digit PIN twice, as prompted.
Continue	After you press Continue the system locks until you enter the PIN again.

Settings

Access and adjust system settings, voice features, as well as phone, navigation and wireless settings.

System



To make adjustments using the touchscreen, select:

Menu Item	Action and Description
Settings	Press the settings icon.
System	
Then select from the following:	
Language	Select to have the touchscreen display and voice controls in any of the selectable language options*.
Distance	Select to display units in kilometers or miles.
Temperature	Select to display units in Celsius or Fahrenheit.
System Prompt Volume	Adjust the volume of voice prompts from the system.
Touch Screen Button Beep	Select to have the system beep to confirm choices made through the touchscreen.
Keyboard Layout	Have the touchscreen keyboard display in QWERTY or ABC format.

SYNC™ 2

Menu Item	Action and Description
Install Applications	Install any downloaded applications or view the current software licenses.
Master Reset	Select to restore factory defaults. This erases all personal settings and personal data.

*Language options are region dependent. Some languages are only supported on screen, not via voice. Visit the regional Ford website for details.

Voice Control



To make adjustments using the touchscreen, select:

Menu Item	Action and Description
Settings	
Voice Control	

Then select from the following:

Interaction Mode	Standard interaction mode provides more detailed interaction and guidance. Advanced mode has less audible interaction and more tone prompts.
Confirmation Prompts	Have the system ask you short questions if it has not clearly heard or understood your request. Note: Even with confirmation prompts turned off, the system may occasionally ask you to confirm settings.
Media Candidate Lists	Candidate lists are possible results from your voice commands. The system simply makes a best guess at your request with these turned off.
Phone Candidate Lists	Candidate lists are possible results from your voice commands. The system simply makes a best guess at your request with these turned off.
Voice Control Volume	This allows you to adjust the system's voice volume level.

Media Player



SYNC™ 2

To make adjustments using the touchscreen, select:

Menu Item	Action and Description
Settings	Press the settings icon.
Media Player	
Then select from the following:	
Autoplay	When this feature is on, the system automatically switches to the media source upon initial connection. This allows you to listen to music during the indexing process. When this feature is off, the system does not automatically switch to the inserted media source.
Bluetooth Devices	Select to connect, disconnect, add or delete a device. You can also set a device as your favorite so that the system automatically attempts to connect to that device at every ignition cycle.
Gracenote® Database Info	This allows you to view the version level of the Gracenote Database.
Gracenote® Management	With this feature on, the Gracenote Database supplies metadata information for your music files. This overrides information from your device. This feature defaults to off.
Cover Art Priority	With this feature on, the Gracenote Database supplies cover art for your music files. This overrides any art from your device. This feature defaults to Media Player.

Navigation



To make adjustments using the touchscreen, select:

Menu Item	Action and Description
Settings	Press the settings icon.
Navigation	
Then select from the following:	
Map Preferences	Switch breadcrumbs on and off.
	Have the system display your turn list top to bottom or bottom to top.

SYNC™ 2

Menu Item	Action and Description
	Switch the Parking POI notification on and off.
Route Preferences	Select shortest route, fastest route or ecological route as your preferred route. This route displays first.
	Always use preferred route. If set to yes, the system only calculates a single route. This speeds up your destination entry process.
	Select a low, medium or high cost for the calculated ecological route. This may incur a time penalty.
	Have the system avoid freeways.
	Have the system avoid toll roads.
	Have the system avoid ferries or car trains.
	Have the system avoid tunnels.
Navigation Preferences	Have the system use guidance prompts.
	Have the system automatically fill in Country information.
	Hazard Spot Warning Have the system activate hazard spot warning in countries where legally allowed.
Traffic Preferences	Have the system avoid traffic problems automatically.
	Switch traffic alert notifications on or off.
	Have the system display accident icons.
	Have the system display traffic jam icons.
	Have the system display closed roads.
	Have the system display road work icons.
	Have the system display incident icons.
	Have the system display icons for areas where difficult driving conditions may occur.
	Have the system display icons for areas where snow and ice on the road may occur.
	Have the system display any smog icons.
Have the system display weather warning icons.	

SYNC™ 2

Menu Item	Action and Description
	Have the system display where there may be reduced visibility.
	Have the system display icons to recommend switching on your radio for traffic announcements.
Avoid Areas	Enter specific areas that you would like to avoid on planned navigation routes.

Phone



To make adjustments using the touchscreen, select:

Menu Item	Action and Description
Settings	Press the settings icon.
Phone	

Then select from the following:

Bluetooth Devices	Connect, disconnect, add or delete a device, as well as save it as a favorite.
Bluetooth	Switch Bluetooth on and off.
Do Not Disturb	Have all calls go directly to your voice mail and not ring inside your vehicle. With this feature turned on, text message notifications are also suppressed and do not ring inside your vehicle.
Emergency Assistance	Switch on or turn off the Emergency Assistance feature. See Information (page 326).
Phone Ringer	Select the type of notification for phone calls - ring tone, beep, text to speech or silent.
Text Message Notification	Select the type of notification for text messages - alert tone, beep, text to speech, or have it be silent.

SYNC™ 2

Menu Item	Action and Description
Internet Data Connection	If compatible with your phone, you can adjust your internet data connection. Select to make your connection profile with the personal area network or to switch off your connection. You can also choose to adjust your settings or have the system always connect, never connect when roaming, or query on connect. Press ? for more information.
Manage Phonebook	Access features, such as automatic phonebook download, re-download your phonebook, add contacts from your phone as well as delete or upload your phonebook.
Roaming Warning	Have the system alert you when in Roaming mode.

Wireless and Internet



Your system has a Wi-Fi feature that creates a wireless network within your vehicle, thereby allowing other devices (such as personal computers or phones) in your vehicle to speak to each other, share files or play games. Using this Wi-Fi

feature, everyone in your vehicle can also access the internet if you have a USB mobile broadband connection inside your vehicle, your phone supports personal area networking or if you park outside a wireless hotspot.

To make adjustments using the touchscreen, select:

Menu Item	Action and Description
Settings	Press the settings icon.
Wireless and Internet	

Then select from the following:

Wi-Fi Settings	<p>Wi-Fi Network (Client) Mode</p> <p>Turns the Wi-Fi feature on and off in your vehicle. Make sure you switch it on for connectivity purposes.</p> <p>Choose a Wireless Network</p> <p>Allows you to use a previously stored wireless network. You can categorize by alphabetical listing, priority and signal strength. You can also choose to search for a network, connect to a network, disconnect from a network, receive more information, prioritize a network or delete a network.</p>
----------------	---

SYNC™ 2

Menu Item	Action and Description
	<p>Gateway (Access Point) Mode</p> <p>Makes SYNC an access point for a phone or a computer when turned on. This forms the local area network within your vehicle for things, such as game playing, file transfer and internet browsing. Press ? for more information.</p>
	<p>Gateway (Access Point) Settings</p> <p>Allows you to view and change settings for using SYNC as the internet gateway.</p>
	<p>Gateway (Access Point) Devices List</p> <p>Allows you to view recent connections to your Wi-Fi system.</p>
USB Mobile Broadband	<p>Instead of using Wi-Fi, your system can also use a USB mobile broadband connection to access the internet. (You must switch on your mobile broadband device on your personal computer before connecting it to the system.) This screen allows you to set up what is your typical area for your USB mobile broadband connection. (USB mobile broadband settings may not display if the device is already on.) You can select the following:</p>
	Country
	Carrier
	Phone Number
	User Name
	Password
Bluetooth Settings	<p>Shows you the currently paired devices as well as giving you your typical Bluetooth options to connect, disconnect, set as favorite, delete and add device. Bluetooth is a registered trademark of the Bluetooth SIG.</p>
Prioritize Connection Methods	<p>Choose your connection methods and change them as needed. You can select to change order and have the system either always attempt to connect using a USB mobile broadband or using Wi-Fi.</p>

SYNC™ 2



The Wi-Fi CERTIFIED Logo is the certification mark of the Wi-Fi Alliance.

Help



E142626

To make adjustments using the touchscreen, select:

Menu Item	Action and Description
Settings	Press the settings icon.
Help	Select Help

Then select from the following:

System Information	Touchscreen system serial number	
	Vehicle Identification Number (VIN)	
	Touchscreen system software version	
	Navigation system version	
	Map database version	
	Gracenote® Database Information and Library version	
View Software Licenses	View the licenses for any software and applications installed on your system.	
Driving Restrictions	Certain features are not accessible when your vehicle is moving.	
Emergency Assistance	Switch on and off the Emergency Assistance feature. See Information (page 326).	
	In Case of Emergency (ICE) speed dial	Allows you to save up to two numbers as ICE contacts for quick access if there is an emergency.

SYNC™ 2

Menu Item	Action and Description	
		The ICE contacts you select appear at the end of the Emergency Assistance call process.
	Edit	Select to access your phone-book and then select the desired contacts. The numbers then appear as options on this screen for the ICE 1 and ICE 2 buttons.
Voice Command List	View categorized lists of voice commands.	



You can also access Help using the voice commands. The system provides allowable voice commands for the current mode.

Press the voice button and when prompted say:

Voice command
Help

You can say help at any time to get assistance with commands, menus or other information.

ENTERTAINMENT

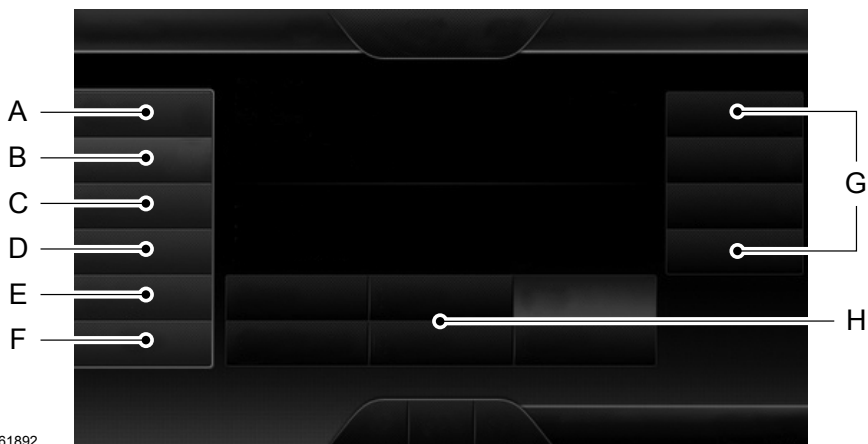

E161892

Message	Message and Description
A	AM
B	FM
C	DAB
D	CD
E	USB
F	Touch this button to scroll down for more options, such as SD Card, BT Stereo and Line In.

Message	Message and Description
G	These buttons provide additional controls for the radio or media source. See the AM/FM radio controls table for more information.
H	Radio memory presets and CD controls.

Note: Some features may not be available in your area. Contact an authorized dealer for more information.

You can access these options using the touchscreen or voice commands.

AM/FM/DAB Radio



The following controls are available for AM/FM/DAB radio

SYNC™ 2

Controls

Item	Action and Description	
AM FM DAB	Touch either tab to listen to the radio. To change between AM, FM and DAB presets, just touch the AM , FM or DAB tab.	
Presets	Save a station by pressing and holding one of the memory preset areas. There is a brief mute while the radio saves the station. Sound returns when finished.	
Scan	Touch this button to go to the next strong AM, FM or DAB radio station. The light on the button illuminates when the feature is on.	
Information	(DAB only)	When the info button is pressed, the system shows the corresponding block number for the active DAB radio station. If you press the info button a second time the radio station name is displayed again.
Tune	For AM and FM only, touch this button to manually enter the desired station number. Touch Enter when you are done.	
TA	Turn on to receive traffic announcements.	
Browse	See a list of all currently available radio stations.	

Options

Menu Item	Action and Description
Sound Settings	Touch this button to adjust settings for:
	Bass
	Midrange
	Treble
	Set Balance and Fade
	DSP occupancy
	Adaptive volume
Radio Text	This allows you to view the information broadcast by FM stations.

SYNC™ 2

Menu Item	Action and Description
AST	AST (Autostore) allows you to have the system automatically store the six strongest stations in your current location.
News announcement	With news announcement option active, the system interrupts active audio source to provide incoming news announcements, if currently tuned station (or last tuned station in case of other media active) supports news.
Regional	With Regional option active, the system stays on the regional subprogram instead of switching to a different frequency with better reception.
Alternate Frequency	With alternative frequency option active, the system re-tunes to a different frequency with better reception for the same station.
Service Linking	With Service Linking active, the system automatically switches from DAB to FM, in case DAB becomes unavailable.

Note: Your vehicle may not have all these sound settings.

Radio Voice Commands



Press the voice button and when prompted say:

Voice command	
Radio	
Then you can say a command similar to the following:	
FM	Say a frequency or preset.
DAB	Say a preset.
Off	
help	

SYNC™ 2

CD



To access, press the lower left corner on the touchscreen, then select:

Menu Item
CD

Insert your CD then select:

Menu Item	Action and Description
Repeat	Touch this button to repeat the currently playing track, all tracks on the disc or switch the feature off if already on.
Shuffle	Touch this button to play the tracks or entire albums in random order, or switch the feature off if already on.
Scan	Touch this button to hear a brief sampling of all available tracks.
More Info	Touch this button to see disc information.
Browse	Touch this button to look through all available CD tracks.

To adjust the Sound Settings, select:

Menu Item
Options
Sound Settings
Then any of the following:
Bass
Midrange
Treble
Set Balance and Fade
DSP occupancy
Adaptive volume

Note: Your vehicle may not have all these sound settings.

CD Voice Commands



If you are listening to a CD, press the voice button on the steering wheel controls. When prompted, say any of the following commands.

If you are not listening to a CD, press the voice button and, after the tone, say:

Voice command
CD

When listening to a CD you can say many commands. Following are a few examples of what you can say.

Voice command
play
pause
Next Track
Previous Track
Help

SD Card Slot and USB Port

The SD card slot and USB port are located in the Media Hub. See **Navigation** (page 334).

SD Card

Note: Your SD card slot is spring-loaded. To remove the SD card, press the card in and the system ejects it. Do not attempt to pull the card to remove it as this could cause damage.

Note: The navigation system also uses this card slot. See **Navigation** (page 334).

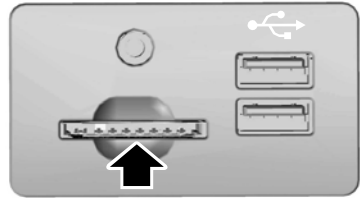

E175710

To access and play music from your device, press the lower left corner of the touchscreen.



E142620

SD logo is a trademark of SD-3C, LLC.

USB Port



E175711

To access and play music from your device, press the lower left corner of the touchscreen.

SYNC™ 2

This feature allows you to plug in media playing devices, memory sticks, flash drives or thumb drives, and charge devices if they support this feature.

Playing Music from Your Device

Note: *The system is capable of indexing up to 30,000 songs.*



Insert your device and select:

Message	Action and Description
USB SD Card	Once the system recognizes your USB or SD card you can then select from the following options:
Repeat	This feature replays the currently playing song or album.
Shuffle	Touch this button to play music on the selected album or folder in random order.
Similar Music	This feature allows you to choose music similar to what is currently playing.
More Info	Touch this button to see disc information, for example current track, artist name, album and genre.
Options	Touch this button to view and adjust various media settings.

Sound

Sound settings allows you to adjust settings for:

Message	Action and Description
Bass	
Midrange	
Treble	
Set Balance and Fade	
DSP	
Adaptive volume	
Media Player Settings	Allows you to select more settings, which is under Media Player. See Settings (page 295).

SYNC™ 2

Message	Action and Description
Device Information	Displays software and firmware information about the currently connected media device.
Update Media Index	Indexes your device when you connect it for the first time and each time the content changes (for example adding or removing tracks) to make sure you have the latest voice commands available for all media on the device.

Note: *Your vehicle may not have all these sound settings.*

Browse

This feature allows you to view the contents of the device. It also allows you to search by categories, for example genre, artist or album.

If you want to view song information, for example Title, Artist, File, Folder, Album, and Genre, touch the on-screen album art.

You can also select:

Message	Action and Description
What's Playing?	To hear how the system pronounces the current band and song. This can be helpful when using voice commands to make sure the system correctly plays your request.

USB and SD Card Voice Commands



Press the voice button and when prompted say:

Voice command	
SD Card	
USB	
Then commands such as the following:	
Browse	
Next Track	
pause	
play	Say the name of what you would like to listen to such as a band, song, album or playlist.

SYNC™ 2

Voice command	
Play Artist ____	*
Play Song ____	*
Similar Music	
Help	

* ____ is a dynamic listing, meaning that it could be the name of anything, such as a group, artist or song. For example you could say "Play artist The Beatles" or "Play song Penny Lane".

Supported Media Players, Formats and Metadata Information

SYNC is capable of hosting nearly any digital media player, including iPod, Zune™, plays from device players, and most USB drives. Supported audio formats include MP3, WMA, WAV and AAC.

It is also able to organize your indexed media from your playing device by metadata tags. Metadata tags, which are descriptive software identifiers embedded in the media files, provide information about the file.

If your indexed media files contain no information embedded in these metadata tags, SYNC may classify the empty metadata tags as unknown.

Bluetooth Audio

The system allows you to stream audio over your vehicle's speakers from your connected, Bluetooth-enabled cell phone.



To access, press the lower left corner on the touchscreen, then select:

Message
BT audio

Bluetooth Audio Voice Commands



The voice system allows you to control your media with a simple voice command. For example to change songs, press the voice button and follow the system prompts.

Line In

WARNINGS



Driving while distracted can result in loss of vehicle control, crash and injury. We strongly recommend that you use extreme caution when using any device that may take your focus off the road. Your primary responsibility is the safe operation of your vehicle. We recommend

WARNINGS

against the use of any handheld device while driving and encourage the use of voice-operated systems when possible. Make sure you are aware of all applicable local laws that may affect the use of electronic devices while driving.



For safety reasons, do not connect or adjust the settings on your portable music player while your vehicle is moving.



Store the portable music player in a secure location, such as the center console or the glove box, when your vehicle is moving. Hard objects may become projectiles in a crash or sudden stop, which may increase the risk of serious injury. The audio extension cable must be long enough to allow the portable music player to be safely stored while your vehicle is moving.

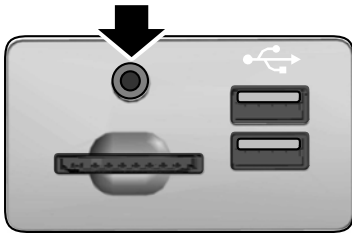

E191800

Your auxiliary input jack allows you to play music from your portable music player over your vehicle's speakers. The jack is located in the center console.

Press the lower left corner of the touchscreen, and then select **Line In**.

To use the auxiliary input jack feature, make sure that your portable music player is designed for use with headphones and that it is fully charged. You also need an audio extension cable with stereo male 1/8-inch (3.5 millimeter) connectors at both ends.

1. Switch off the engine, radio and portable music player. Set the parking brake and put the transmission in position Park (P).
2. Attach one end of the audio extension cable to the headphone output of your player and the other end into the adapter in one of the jack inside the center console.
3. Press the lower left corner on the touchscreen. Select either a tuned FM station or a CD (if there is a CD already loaded into the system).
4. Adjust the volume as desired.
5. Turn the portable music player on and adjust the volume to half of the maximum.
6. Press the lower left corner on the touchscreen. Then select:

Menu Item	
Line In	You should hear audio from your portable music player although it may be low.

SYNC™ 2

Menu Item	
	Adjust the sound on your portable music player until it reaches the level of the FM station by switching back and forth between the controls.

Troubleshooting

- Do not connect the audio input jack to a line level output. The jack only works correctly with devices that have a headphone output with a volume control.

- Do not set the portable music player's volume level higher than is necessary to match the volume of the CD or FM radio as this causes distortion and reduces sound quality.
- If the music sounds distorted at lower listening levels, turn the portable music player volume down. If the problem persists, replace or recharge the batteries in the portable media player.
- Control the portable media player in the same manner when used with headphones, as the auxiliary input jack does not provide control (such as Play or Pause) over the attached portable media player.

PHONE



E161968

Item	Menu Item
A	Phone
B	Speed dial
C	Phonebook

SYNC™ 2

Item	Menu Item
D	Call History
E	Messaging
F	Settings

Hands-free calling is one of the main features of SYNC. Once you pair your cell phone, you can access many options using the touchscreen or voice commands. While the system supports a variety of features, many are dependent on your cell phone's functionality.

At a minimum, most cell phones with Bluetooth wireless technology support the following functions:

- Answering an incoming call.
- Ending a call.
- Dialing a number.
- Call waiting notification.
- Caller ID.

Other features, such as text messaging using Bluetooth and automatic phonebook download, are phone-dependent features. To check your phone's compatibility, see your phone's user manual or the local Ford website.

Pairing Your Cell Phone for the First Time

WARNING



Driving while distracted can result in loss of vehicle control, crash and injury. We strongly recommend that you use extreme caution when using any device that may take your focus off the road. Your primary responsibility is the safe operation of your vehicle. We recommend against the use of any handheld device while driving and encourage the use of voice-operated systems when possible. Make sure you are aware of all applicable local laws that may affect the use of electronic devices while driving.

The first thing you must do to use the phone features of SYNC is to pair your Bluetooth-enabled cell phone with SYNC. This allows you to use your cell phone in a hands-free manner.

Touch the upper left corner of the touchscreen:

Menu Item	Action and Description
Pair phone	
Find SYNC	<p>Follow the on-screen instructions.</p> <p>Make sure that Bluetooth is set to On and that your cell phone is in the correct mode. See your cell phone's manual if necessary.</p> <ol style="list-style-type: none"> 1. Select SYNC and a six-digit PIN appears on your device. 2. If you are prompted to enter a PIN on your device, it does not support Secure Simple Pairing. To pair, enter the PIN displayed on the touchscreen. Skip the next step.

SYNC™ 2

Menu Item	Action and Description
	<ol style="list-style-type: none"> 3. When prompted on your cell phone's display, confirm that the PIN provided by SYNC matches the PIN displayed on your cell phone. 4. The display indicates when the pairing is successful. 5. SYNC may prompt you with more cell phone options. For more information on your cell phone's capability, see your cell phone's manual and visit the website.

Pairing Subsequent Cell Phones

Make sure that Bluetooth is set to **On** and that your cell phone is in the correct mode. See your device's manual if necessary.

To pair a subsequent cell phone, select:

Menu Item	Action and Description
Phone	
Settings	
Bluetooth Devices	
Add Device	
Find SYNC	<p>Follow the on-screen instructions.</p> <p>Make sure that Bluetooth is set to On and that your cell phone is in the correct mode. See your cell phone's manual if necessary.</p> <ol style="list-style-type: none"> 1. Select SYNC and a six-digit PIN appears on your device. 2. If you are prompted to enter a PIN on your device, it does not support Secure Simple Pairing. To pair, enter the PIN displayed on the touchscreen. Skip the next step. 3. When prompted on your cell phone's display, confirm that the PIN provided by SYNC matches the PIN displayed on your cell phone. 4. The display indicates when the pairing is successful. 5. SYNC may prompt you with more cell phone options. For more information on your cell phone's capability, see your cell phone's manual and visit the website.

Making Calls



Press the voice button and say a command similar to the following:

Voice command
Call
Dial

You can say the name of a person from your phone book to call or say a number to dial. For example "Call Jenny" or "Dial 867-5309".



To end the call or exit phone mode, press and hold the phone button.

Receiving Calls

During an incoming call, an audible tone sounds. Call information appears in the display if it is available.



To accept the call, select:

Menu Item
Accept

Note: You can also accept the call by pressing the phone button on the steering wheel.



To reject the call, select:

Menu Item
Reject

Note: You can also reject the call by pressing the phone button on the steering wheel.

Ignore the call by doing nothing. SYNC logs it as a missed call.

Phone Menu Options

Press the top left corner on the touchscreen to select from the following options:

Menu Item	Action and Description
Phone	Touch this button to access the on-screen numerical pad to enter a number and place a call. During an active call, you can also choose any of these options:
	Mute Call
	Hold Call
	Hands-free off
	Join Calls
	End
Speed dial	Select to call stored contacts.

Menu Item	Action and Description
Phone-book	Touch this button to access and call any contacts in your previously downloaded phonebook. The system places the entries in alphabetical categories summarized at the top of the screen
	To turn on contact picture settings, if your device supports this feature, select:
	Phone
	Settings
	Manage Phonebook
	Display Photos from Phonebook
	Certain smart phones may support transferring street addresses when listed with phonebook contact information. If your cell phone supports this feature, you can select and use these addresses as destinations and save them as favorites.
Call History	<p>Note: This is a cell phone-dependent feature. If your cell phone does not support downloading call history using Bluetooth, SYNC keeps track of calls made with the SYNC system.</p> <p>After you connect your Bluetooth-enabled cell phone to SYNC, you can access any previously dialed, received or missed calls. You can also choose to save these to:</p>

Menu Item	Action and Description	
	Favorites	Quick Dial
Messaging	Send text messages using the touchscreen. See Text Messaging later in this section.	
Settings	Touch this button to access various phone settings, for example turning Bluetooth on and off, managing your phonebook and more. See Phone Settings later in this section	

Text Messaging

WARNING



Local laws may prohibit some or all of the text messaging functions while driving. Check your local road rules before using these functions.

Note: *Downloading and sending text messages using Bluetooth are cell phone-dependent features.*

Note: *Certain features in text messaging are speed-dependent and not available when your vehicle is traveling at speeds over 8 km/h.*

Note: *SYNC does not download read text messages from your cell phone.*

You can send and receive text messages using Bluetooth, read them aloud and translate text messaging acronyms, for example LOL.

SYNC™ 2

Touch the top left corner of the display, then select:

Menu Item
Phone
Messaging
Then any of the following:
Listen (speaker icon)
Dial
Send Text

Menu Item
View
Delete
Delete All

Composing a Text Message

Note: *This is a speed-dependent feature. It is unavailable when your vehicle is traveling at speeds over 8 km/h.*

Note: *Downloading and sending text messages using Bluetooth are cell phone-dependent features.*

To compose and send a text message, select:

Menu Item	Action and Description
Phone	
Messaging	
Send Text	Enter a cell phone number or choose from your phonebook.
Edit Text	Allows you to customize the pre-defined message or create a message on your own.
Send	Sends the message as it is.

You can then preview the message, verify the recipient as well as update the message list, and send it to a connected device, for example a USB drive.

Text Message Options

Messages
I'll call you back in a few minutes.
I just left, I'll be there soon.
Can you give me a call?
I'm on my way.
I'm running a few minutes late.

Messages
I'm ahead of schedule, so I'll be there early.
I'm outside.
I'll call you when I get there.
OK
Yes
No
Thanks

SYNC™ 2

Messages
Stuck in traffic.
Call me later.

Messages
LOL

Receiving a Text Message

When a new message arrives, an audible tone sounds and the screen displays a pop-up with the caller name and ID, if supported by your cell phone. You can select:

Menu Item	Action and Description
View	To view the text message.
Listen	For SYNC to read the message to you.
Dial	To call the contact.
Ignore	To exit the screen.

Phone Settings

To enter the phone settings menu select:

Menu Item	Action and Description
Phone	
Settings	

Then any of the following:

Bluetooth Devices	Connect, disconnect, add or delete a device, as well as save it as a favorite.
Bluetooth	To turn Bluetooth off or on.
Do Not Disturb	If you want all calls to go directly to your voicemail and not ring in the vehicle. When this feature is on, text message notifications do not ring inside the cabin either.
Emergency Assistance	Switch the Emergency Assistance feature on or off. See Information (page 326).
Phone Ringer	Select the ring tone you want to hear when you receive a call. Choose from possible system ring tones, your currently paired cell phone's ring tone, a beep, text-to-speech or a silent notification.

SYNC™ 2

Menu Item	Action and Description
Text Message Notification	Select a text message notification, if supported by your cell phone. Choose from possible system alert tones, text-to-speech or silent.
Internet Data Connection	If your cell phone is compatible, use this screen to adjust your internet data connection. Select to make your connection profile with the personal area network or to turn off your connection. You can also choose to adjust your settings or have the system always connect, never connect when roaming or query on connect. Press ? for more information.
Manage Phonebook	To access features such as automatic phonebook download, re-download your phonebook, add contacts from your cell phone as well as delete or upload your phonebook.
Roaming Warning	To have the system alert you when your cell phone is in roaming mode.

Phone Voice Commands



Press the voice button and when prompted say any of the following or a similar command:

Voice command
Call Voicemail
Listen to Message
Reply to Message
Pair Phone
Help

INFORMATION

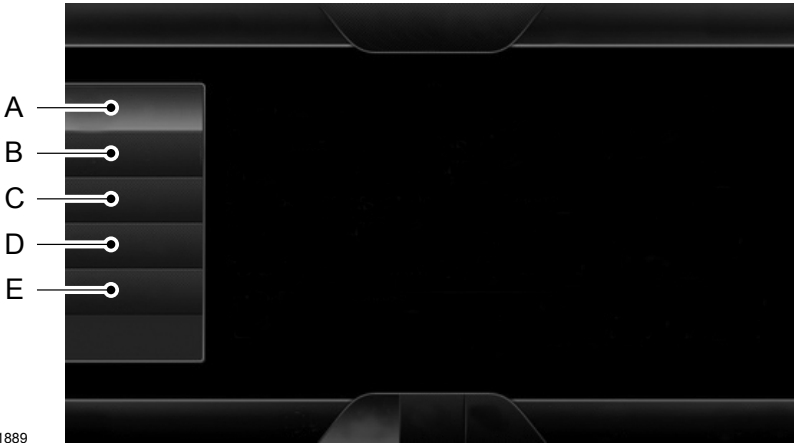

E161889

Item	Menu Item
A	Traffic
B	Notifications
C	Calendar
D	Apps
E	Where Am I?

i If your vehicle is equipped with Navigation, touch the **i** (Information) button to access these features. If your vehicle is not equipped with Navigation, touch the corner of the touchscreen with the green tab.

Notifications

Press Notifications, and then choose from any of the following services:

Menu Item	Action and Description
View	The complete message
Delete	The message
Delete All	Messages

This screen displays any system messages (such as an SD card fault).

Note: *The system alerts you to any messages by turning the information icon yellow. After you read or delete the messages, the icon returns to white.*

Calendar

Press **Calendar**. You can view the current calendar by day, week or month.

Emergency Assistance (If Equipped)

WARNINGS



For this feature to work, your mobile phone must be Bluetooth capable and compatible with the system.



Always place your mobile phone in a secure location inside your vehicle. Failure to do so may cause serious injury to someone or damage the phone which could prevent Emergency Assistance from working correctly.



Unless the Emergency Assistance setting is set to on prior to a collision, the system will not attempt to place an emergency call which could delay the response time, potentially increasing the risk of serious injury or death. Do not wait for Emergency Assistance to make an

WARNINGS

emergency call if you can do it yourself. Dial emergency services immediately to avoid a delayed response time. If you do not hear Emergency Assistance within five seconds of the crash, the system or cell phone may be damaged or non-functional.

Note: *Before setting the feature on, please read the important notice about the Emergency Assistance feature and the Emergency Assistance privacy notice later in this section for important information.*

Note: *When you switch Emergency Assistance on or off, the setting applies to all paired mobile phones. If you switch Emergency Assistance off and a previously paired phone connects when you switch the ignition on, either a voice message plays, a display message or icon is shown, or both.*

Note: *Every mobile phone operates differently. While Emergency Assistance works with most mobile phones, some mobile phones may experience difficulties using this feature.*

Note: *Ford is not the provider of the emergency services contacted by SYNC when an emergency call is initiated. Ford does not accept any liability in relation to the provision, quality or timeliness of those services.*

If a crash deploys an airbag or triggers the fuel pump shut off, the system may contact emergency services by dialing the emergency assistance number through a paired and connected cell phone. For more information about the system and Emergency Assistance, visit the regional Ford website.

Note: *In case of an emergency, Emergency Assistance, as a means of communication aid, can help you contact specific rescue departments of public security. Emergency Assistance does not implement the rescue operations. The local public security department deploys specific rescue operations according to the actual situation.*

See **Supplementary Restraints System** (page 24). Important information regarding airbag deployment is in this chapter.

See **Roadside Emergencies** (page 184). Important information regarding the fuel pump shut-off is in this chapter.

Setting Emergency Assistance On

From the information menu you can select **Apps** and go to the Emergency Assistance settings by pressing on **Emergency Assist**. In the upcoming menu you can switch the feature **On** or **Off**.

If you switch on this feature, a confirmation message appears in the display when your cell phone connects and your vehicle starts.

Menu Item
Apps
Emergency Assistance
On

If you switch off this feature, the dialog allows you to set a reminder.

Off with reminder provides a display and voice reminder when your cell phone connects and your vehicle starts.

Off without reminder provides a display reminder only without a voice reminder when your cell phone connects.

To make sure that Emergency Assistance works correctly:

- The system must have power and be working correctly at the time of the crash and during feature activation and use.
- You must switch on the feature before a crash.
- You must have a cell phone connected to the system.
- In certain countries, it may be necessary to have a valid and registered SIM card with credit in order to place and maintain an emergency call.
- A connected cell phone must have the ability to make and maintain an outgoing call at the time of the crash.
- A connected cell phone must have adequate network coverage, battery power and signal strength.
- Your vehicle must have battery power.

Note: *This feature only works in countries or regions where SYNC Emergency Assistance can call the local emergency services. Visit the regional Ford website for details.*

In the Event of a Crash

Note: *Not every crash deploys an airbag or triggers the fuel pump shut off (which may turn on Emergency Assistance). However, if Emergency Assistance is triggered the system tries to contact the emergency services. If a connected cell phone sustains damage or loses connection to the system, it searches for and tries to connect to any available previously paired cell phone. The system attempts to dial the local emergency services.*

Before making a call:

- The system provides a short time window (approximately 10 seconds) to cancel the call. If you do not cancel the call, the system attempts to dial the local emergency assistance service.
- The system plays a message letting you know when it attempts to make an emergency call. You can cancel the call by selecting the relevant button or by pressing the end call button on the steering wheel.
- If you do not cancel the call and SYNC makes a successful call, an introductory message plays for the emergency operator. After this message, there is hands-free communication between your vehicle's occupants and the operator.

During a call:

- An introductory message plays for the emergency operator.
- Emergency Assistance uses your vehicle GPS or cellular network information when available to determine the most appropriate language to use. It alerts the emergency operator of the crash and delivers the introductory message. This may include your vehicle GPS coordinates.

- The language the system uses to interact with the occupants of your vehicle may differ from the language used to deliver information to the emergency operator.
- After the delivery of the introductory message the voice line opens so that you can speak hands-free with the emergency operator.
- When the line is connected, you must be prepared to provide your name, phone number and location information immediately.

Note: *While the system provides information to the emergency operator, the system plays a message letting you know it is sending important information. It then lets you know when the line is open to start hands-free communication.*

Note: *During an Emergency Assistance call, an emergency priority screen appears which contains vehicle GPS coordinates when available.*

Note: *It is possible that GPS location information is not available at the time of the crash; in this case, Emergency Assistance will still attempt to place an emergency call.*

Note: *It is possible that the emergency services will not receive the GPS coordinates; in this case, hands-free communication with an emergency operator is available.*

Note: *The emergency operator may also receive information from the cellular network such as cell phone number, cell phone location and cell phone carrier name independent from SYNC Emergency Assistance.*

SYNC™ 2

Emergency Assistance may not work if:

- Your cell phone or Emergency Assistance hardware sustains damage in the crash.
- The vehicle battery or the system has no power.
- A crash ejects your cell phone from your vehicle.
- You do not have a valid and registered SIM card with credit in your cell phone.
- You are in a country or region where the SYNC Emergency Assistance cannot place the call. Visit the regional Ford website for details.

Important Information about the Emergency Assistance Feature

Emergency Assistance does not currently call emergency services in some countries.

Visit the regional Ford website for latest details.

Emergency Assistance Privacy Notice

When you switch on Emergency Assistance, it may disclose to emergency services that your vehicle has been in a crash involving the deployment of an airbag or activation of the fuel pump shut off. This feature has the capability to disclose your location information to the emergency operator or other details about your vehicle or crash to provide the most appropriate emergency services.

If you do not want to disclose this information, do not switch on the feature.

Where Am I?

For vehicle location and information select:

Menu Item	Action and Description
Information	
Help	
Then select:	
Where Am I?	View your vehicle's current location. If your vehicle is equipped with navigation this screen will show your location coordinates and give your location information like the current street address. If your vehicle is not equipped with navigation, you will only see the location coordinates.

CLIMATE

Press the lower right corner on the touchscreen to access your climate control features. Depending on your vehicle line

and option package, your climate screen may look different from this screen.

Note: You can switch temperature units between Fahrenheit and Celsius. See **Settings** (page 295).

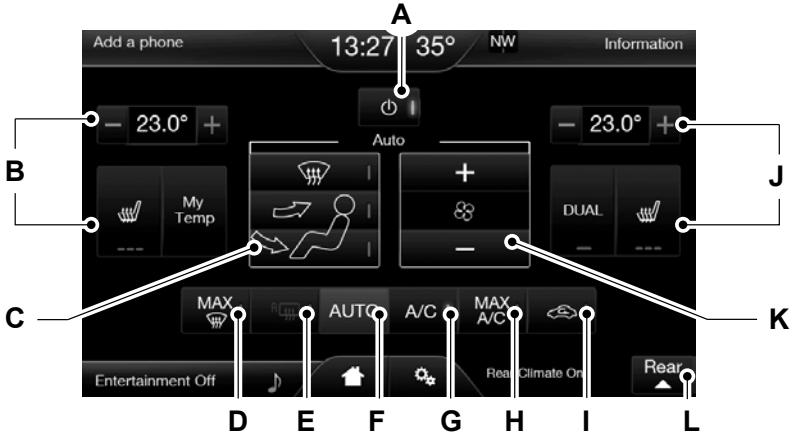

E207390

- A **Power:** Touch to switch the system off and on. Outside air cannot enter your vehicle when you switch off the system.
- B **Passenger settings:** Touch + or – to adjust the temperature.
Touch the heated seat icon to turn the heated seat off and on.
Touch **MyTemp** to select your preset temperature setpoint. Touch and hold **MyTemp** to save a new preset temperature setpoint.
- C **Manual airflow distribution controls:**
 - Floor and Defrost:** Distributes air through the windshield defroster vents, demister vents and floor vents.
 - Panel:** Distributes air through the instrument panel vents.
 - Panel and Floor:** Distributes air through the instrument panel vents, demister vents, floor vents.
 - Floor:** Distributes air through the demister vents and floor vents.
 - Defrost:** Touch to clear the windshield of fog and thin ice. When on, defrost provides outside air to reduce window fogging and distributes air through the windshield defroster vents and demister vents.

SYNC™ 2

- D **MAX Defrost:** Touch to switch on maximum defrosting. Outside air flows through the windshield vents, air conditioning automatically turns on, fan adjusts to the highest speed and temperature is set to the full heat position. You can also use this setting to defog or clear the windshield of a thin covering of ice. The heated rear window also automatically turns on when you select MAX Defrost.
- Note:** To prevent window fogging, you cannot select recirculated air when defrost is on.
- E **Heated rear window:** Turns the heated rear window on and off.
- F **AUTO:** Touch to switch on automatic operation. Then set the temperature using the temperature control. Fan speed, air distribution, air conditioning operation, and outside or recirculated air are automatically adjusted to heat or cool the vehicle to maintain the desired temperature. You can also turn off dual zone mode by pressing and holding the button for more than two seconds.
- G **A/C:** Touch to switch the air conditioning on or off. To improve the time to reach a comfortable temperature in hot weather, drive with the windows open until you feel cold air through the air vents. Use A/C with recirculated air to improve cooling performance and efficiency.
- H **MAX A/C:** Touch for maximum cooling. Recirculated air flows through the instrument panel vents, air conditioning automatically turns on and the fan automatically adjusts to the highest speed. Touch again for normal A/C operation. MAX A/C is more economical and efficient than normal A/C mode.
- I **Recirculated air:** Touch to switch between outside air and recirculated air. The air currently in the passenger compartment recirculates. This can reduce the time needed to cool the interior (when used with A/C) and reduce unwanted odors from entering your vehicle.
- J **Driver settings:** Touch + or – to adjust the temperature.
- DUAL:** Touch to switch on independent driver and passenger temperature control.
- Touch the heated seat icon to turn the heated seat off and on.
- K **Fan speed:** Touch + or - to adjust fan speed.
- L **Rear Passenger Climate Control:** Touch to toggle the rear passenger climate control bar on or off.

Rear Passenger Climate Control Bar

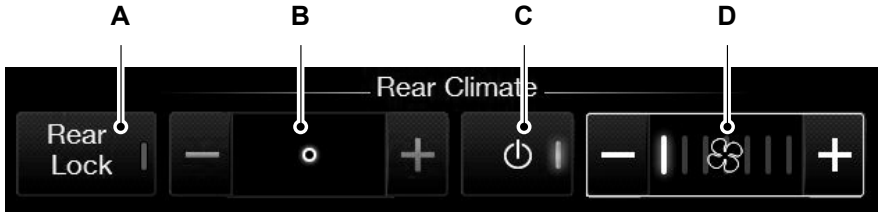

E206113

A	Rear climate control lock: Touch to lock rear passenger climate control. Rear climate control cannot be operated if this is switched on.
B	Rear temperature control: Touch to adjust the temperature of the rear passenger compartment.
C	Rear climate control power: Touch to switch the system on and off.
D	Rear fan speed control: Touch to adjust the volume of air circulated to the rear of the passenger compartment.

Climate Control Voice Commands



Press the voice button on the steering wheel controls. When prompted, say any of the following or a similar command:

Voice commands	
climate (automatic auto) [on]	
Climate Off	
Climate Set Temperature ____	Adjust the temperature to between 15°C - 30°C

NAVIGATION

Note: The navigation SD card must be in the SD card slot to operate the navigation system. If you need a replacement SD card, contact an authorized dealer.

Note: Handle the SD card with care to avoid contamination or damage. Never touch the metal contacts. Do not clean the SD card with anything other than a soft cloth. Never attempt to use an SD card that has been cracked, deformed or repaired using adhesive, as doing so may damage the equipment. Do not put on any sticker or write anything on the SD card. Do not attempt to alter the data contained on the SD card in any way.

Note: The SD card slot is spring-loaded. To remove the SD card, just push the card in and release it. Do not attempt to pull the card out to remove it; this could cause damage.

Your navigation system is comprised of two main features, destination mode and map mode.

Destination Mode

To set a destination press the green corner of your touchscreen, then press:

Menu Item
Dest.
Choose any of the following:
My Home
Favourites
Previous Destinations
Place of interest
Emergency
Address
Junction
Town centre
Map*
Edit Route
Cancel Route

* - For some vehicles it may display "Latitude/Longitude".

SYNC™ 2

To set your destination, enter the necessary information into the highlighted text fields (in any order).

For an address destination entry, press:

Menu Item	Action and Description
Go	Pressing this button makes the address location appear on the map.

To choose a previous destination, press:

Menu Item	Action and Description
Previous Destinations	The last 20 destinations you have selected appear.

Once you have chosen your destination press:

Menu Item	Action and Description
Destination	This will start the route calculation and guidance.
Avoid Areas	Your pre-set selections are considered when your route is calculated. For more information on these selections, see Setting Your Navigation Preferences later in this chapter.

Michelin Travel Guide (If Equipped)

The Michelin travel guide is a service which provides additional information about certain places of interests (POI) such as restaurants, hotels and touristic sites (if available).

If you have paired your phone with the system, you can press the phone button to directly establish a call with the selected POI.

Note: *Not all features are available in all languages and countries.*

Places of Interest (POI) Categories

Main categories
Fuel Station
Parking
Food, Drink and Dining
Automotive
Travel and Transportation
Shopping
Financial
Entertainment & Arts
Emergency

SYNC™ 2

Main categories
Recreation & Sports
Community
Government
Health & Medicine
Domestic Services

To expand these listings, press the + in front of the listing.

The system also allows you to sort alphabetically or by distance.

Setting Your Navigation Preferences



Select settings for the system to take into account when planning your route.

To access the settings options, press:

Menu Item
Settings
Navigation
Then select any of the following:

Map Preferences

Menu Item	Second Level Messages, Actions and Descriptions
Map Preferences	
Then select any of the following:	
Breadcrumbs	Display your vehicle's previously traveled route with white dots. You can switch this feature:
	On <input type="checkbox"/> Off <input type="checkbox"/>
Turn List Format	Have the system display your turn list:
	Top to Bottom <input type="checkbox"/> Bottom to Top <input type="checkbox"/>
Parking POI Notification	When parking point of interest notification is on, the icons display on the map when you get close to your destination. This may not be very useful in dense areas, and may clutter the map when other points of interest are displayed. Set the automatic parking point of interest notification. You can switch this feature:
	On <input type="checkbox"/> Off <input type="checkbox"/>

SYNC™ 2

Route Preferences

Menu Item	Second Level Messages, Actions and Descriptions		
Route Preferences			
Then select any of the following:			
Preferred Route	Choose to have the system display your chosen route type.		
	Shortest	Fastest	Eco
Always use Preferred Route	Bypass route selection in destination programming. The system only calculates one route based on preferred route setting. When activated, the system uses your selected route type to calculate only one route to the desired destination.		
Eco Time Penalty	Select a level of cost for the calculated Eco Route. The higher the setting, the longer the time allotment is for the route.		
Avoid	When activated, you can choose to have the system avoid motorways, toll roads, ferries, car trains and tunnels when planning your route.		

Navigation Preferences

Menu Item	Second Level Messages, Actions and Descriptions	
Navigation Preferences		
Then select any of the following:		
Guidance Prompts	Select the type of prompts the system uses.	
Auto-fill country	Have the system automatically fill in the country based on the information already entered into the system. You can switch this feature:	
	On	Off
Hazard Spot Warning	Have the system activate hazard spot warning in countries where legally allowed.	

SYNC™ 2

Traffic Preferences

Menu Item	Second Level Messages, Actions and Descriptions	
Traffic Preferences		
Then select any of the following:		
Avoid Traffic Problems	You can choose how you want the system to handle traffic problems along your route.	
	Automatic	Have the system reroute you to avoid traffic incidents that develop and impact the current route. The system does not provide a traffic alert notification
	Manual	Have the system always provide a traffic alert notification for traffic incidents along the planned route. You have a choice to accept or ignore the notification before making the route deviation.
Traffic alert notification	Turn the traffic alert notifications on or off.	
Traffic Preferences	You can choose to turn on any of the following Traffic alert categories.	
	Have the system display accident information.	
	Have the system display traffic jam information.	
	Have the system display closed roads.	
	Have the system display road work information.	
	Have the system display incident information.	
	Have the system display icons for areas where difficult driving conditions may occur.	
	Have the system display icons for areas where snow and ice on the road may occur.	
Have the system display any smog information.		

SYNC™ 2

Menu Item	Second Level Messages, Actions and Descriptions
	Have the system display weather warning information.
	Have the system display where there may be reduced visibility.
	Have the system display icons to recommend switching on your radio for traffic announcements.

Avoid Area

Menu Item	Second Level Messages, Actions and Descriptions
Avoid Areas	Choose areas which you want the system to avoid when calculating a route for you.
Then select any of the following:	
Add	Once you make a selection, the system tries to avoid the area(s) if possible for all routes. To program an entry, press:
Delete	To delete a section choose the listing on the screen. The screen will change, then press:

Map Mode

Press the green bar in the upper right area of the touchscreen to view map mode. Map mode shows advanced viewing comprised of both 2D city maps as well as 3D landmarks (when available).

2D city maps show detailed outlines of buildings, visible land use and land elements and detailed railway infrastructure for the most essential cities around the globe. These maps also contain features, such as town blocks, building footprints and railways.

3D landmarks appear as clear, visible objects that are typically recognizable and have a certain tourist value. The 3D landmarks appear in 3D map mode only. Coverage varies and improves with updated map releases.



Change the appearance of the map display by repeatedly pressing the arrow button in the upper left corner of the screen. It toggles between three different map modes:



Heading up (2D map) This always shows the direction of forward travel to be upward on the screen. This view is available for map scales up to 5 km/h.



North up (2D map) always shows the northern direction to be upward on the screen.



3D map mode provides an elevated perspective of the map. This viewing angle can be adjusted and the map can be rotated 180 degrees by touching the map twice, and then dragging your finger along the shaded bar with arrows at the bottom of the map.

You can also select the following options:

Menu Items	
View	Switches between full map, street list and exit view in route guidance.
Menu	Displays a pop-up box that allows direct access to navigation settings.



Press the speaker button on the map to mute route guidance. When the light on the button illuminates, the feature is on. The speaker button appears on the map only when route guidance is active.



Re-center the map by pressing this icon whenever you scroll the map away from your vehicle's current location.

Auto Zoom

Press the green bar to access map mode, then select the **+** or **-** zoom button to bring up the zoom level and Auto buttons on the touchscreen. When you press **Auto**, Auto Zoom turns on and **Auto** displays in the bottom left corner of the screen in the map scale. The map zoom level then synchronizes with vehicle speed. The slower your vehicle is traveling, the farther the map zooms in; the faster your vehicle is traveling, the farther the map zooms out. To switch the feature off, just press the **+** or **-** button again.

In 3D mode, rotate the map view by swiping your finger across the shaded bar with the arrows.

The ETA box under the zoom buttons appears when a route is active and displays the distance and time to your destination. If the button is pressed, a pop up appears with the destination listed (and waypoint if applicable) along with mileage and time to destination. You may also select to have either the estimated time to reach your destination or your estimated arrival time.

Map Icons



Vehicle mark shows the current location of your vehicle. It stays in the center of the map display, except when in scroll mode.



Scroll cursor allows you to scroll the map; the fixed icon is in the center of the screen. The map position closest to the cursor is in a window on the top center part of the screen.



Address book entry default icon(s) indicates the location on the map of an address book entry. This is the default symbol shown after the entry has been stored to the Address Book by any method other than the map. You can select from any of the 22 icons available. You can use each icon more than once.



Home indicates the location on the map currently stored as the home position. You can only save one address from the Address Book as your Home entry. You cannot change this icon.



POI (Point Of Interest) icons indicate locations of any point of interest categories you choose to display on the map. You can choose to display three point of interest categories on the map at one time.

SYNC™ 2



Starting point indicates the starting point of a planned route.



Waypoint indicates the location of a waypoint on the map. The number inside the circle is different for each waypoint and represents the position of the waypoint in the route list.



Destination symbol indicates the ending point of a planned route.



Next maneuver point indicates the location of the next turn on the planned route.



No GPS symbol indicates that insufficient GPS satellite signals are available for accurate map positioning. This icon may display under normal operation in an area with poor GPS access.

Quick-touch Buttons

When in map mode, touch anywhere on the map display to access the following options:

Menu Item	Action and Description	
Set as Dest	Touch this button to select a scrolled location on the map as your destination. You may scroll the map by pressing your index finger on the map display. When you reach the desired location, simply let go and then touch this button.	
Set as Waypoint	Touch this button to set the current location as a waypoint.	
Save to Favorites	Touch this button to save the current location to your favorites.	
POI Icons	Touch this button to select icons to display on the map. You can select up to three icons to display on the map at the same time. You can switch these features:	
	<table border="1"> <tr> <td>On</td> <td>Off</td> </tr> </table>	On
On	Off	
Cancel Route	Touch this button to cancel the active route.	
Traffic List	Touch this button to show a list of traffic incidents.	

SYNC™ 2

View/Edit Route

Access these features when a route is active:

Menu Item
View Route
Edit Destination/Waypoints
Edit Turn List
Detour
Edit Route Preferences
Edit Traffic Preferences
Cancel Route

HERE is the digital map provider for the navigation application. If you find map data errors, you may report them directly to HERE by going to www.here.com. HERE evaluates all reported map errors and responds with the result of their investigation by e-mail.

Navigation Map Updates

Annual navigation map updates are available for purchase through your dealership.

Navigation Voice Commands



When in navigation mode, press the voice button on the steering wheel controls.

After the tone, say any of the following or a similar command:

Voice command
Destination
Zoom out
Zoom in
Where Am I
help

The following commands can only be used when a navigation route is active:

Voice command
Reroute
Cancel Route
Show whole route
Repeat last instruction
Show route summary

SYNC™ 2

One-shot Destination Street Address

To set a destination with voice commands, you can say:

Voice Command	Action and Description
Find an Address	The system asks you to say the full address and displays an example on-screen.

You can then speak the address naturally, such as "One two three four Main Street, Any town".

Traffic Information

Traffic information is provided through an arrangement with Intelematics Australia Pty Ltd. For license terms and conditions refer to the Appendices. Traffic information is based on data provided with the permission of one or more third parties. Please note: Should Ford's arrangement with Intelematics Australia Pty Ltd cease for any reason, the ongoing provision of traffic information cannot be guaranteed.

SYNC™ TROUBLESHOOTING

Your SYNC system is easy to use. However, should questions arise, please refer to the tables below.

To check your mobile phone's compatibility, visit the regional Ford website.

Mobile phone issues		
Issue	Possible cause	Possible solution
A lot of background noise during a phone call.	The audio control settings on your mobile phone may be affecting SYNC performance.	Refer to your device's manual about audio adjustments.
During a call, I can hear the other person but they cannot hear me.	Possible mobile phone malfunction.	Try switching off your mobile phone, resetting it or removing the battery, then trying again.
		Make sure that the microphone for SYNC is not set to off.
SYNC is not able to download my phonebook.	This is a mobile phone-dependent feature.	Check your mobile phone's compatibility.
	Possible mobile phone malfunction.	Try switching off your mobile phone, resetting it or removing the battery, then trying again.
		Try pushing your phonebook contacts to SYNC by selecting the option to add.

SYNC™ 2

Mobile phone issues		
Issue	Possible cause	Possible solution
		You must switch on your mobile phone and the automatic phonebook download feature on SYNC.
The system says "Phonebook downloaded" but my SYNC phonebook is empty or is missing contacts.	Limitations on your mobile phone's capability.	Try pushing your phonebook contacts to SYNC by selecting the option to add.
		If the missing contacts are stored on your SIM card, try moving them to your mobile phone's memory.
		Remove any pictures or special ring tones associated with the missing contact.
		You must switch on your mobile phone and the automatic phonebook download feature on SYNC.
I am having trouble connecting my mobile phone to SYNC.	This is a mobile phone-dependent feature.	Check your mobile phone's compatibility.
	Possible mobile phone malfunction.	Try switching off your mobile phone, resetting it or removing the battery, then trying again.
		Try deleting your device from SYNC and deleting SYNC from your device, then trying again.
		Always check the security and auto accept prompt settings relative to the SYNC Bluetooth connection on your mobile phone.
		Update your mobile phone's firmware.
		Switch off the auto download setting.
Text messaging is not working on SYNC.	This is a mobile phone-dependent feature.	Check your mobile phone's compatibility.
	Possible mobile phone malfunction.	Try switching off your mobile phone, resetting it or removing the battery, then trying again.
	iPhone	<ul style="list-style-type: none"> • Go to your mobile phone's Settings. • Go to the Bluetooth Menu.

SYNC™ 2

Mobile phone issues		
Issue	Possible cause	Possible solution
		<ul style="list-style-type: none"> • Make sure the connection status shows Not Connected. • Press the blue circle to enter the next menu. • Turn on Show Notifications. • Turn on Sync Contacts. <p>Your iPhone is now set up to forward incoming text messages to SYNC. Repeat these steps for every other Sync vehicle you are connected to. Your iPhone will only forward incoming text messages to SYNC if it is unlocked. Replying to text messages using SYNC is not supported by iPhone. Text messages from third party applications are not supported.</p>
Audible text messages do not work on my mobile phone.	This is a mobile phone-dependent feature.	<p>Your mobile phone must support downloading text messages through Bluetooth to receive incoming text messages.</p> <p>Access the text messaging menu of SYNC to see if your mobile phone supports the feature. Press the PHONE button and then scroll and select the option for text messaging, then press OK.</p>
	This is a mobile phone limitation.	Because each mobile phone is different, refer to your device's manual for the specific mobile phone you are pairing. In fact, there can be differences between mobile phones due to brand, model, service provider and software version.

SYNC™ 2

USB and media issues		
Issue	Possible cause	Possible solution
I am having trouble connecting my device.	Possible device malfunction.	Try switching off the device, resetting it or removing the battery, then try again.
		Make sure you are using the manufacturer's cable.
		Make sure you correctly insert the USB cable into the device and the vehicle USB port.
		Make sure that the device does not have an auto-install program or active security settings.
SYNC does not recognize my device when I start my vehicle.	This is a device limitation.	Make sure you are not leaving the device in your vehicle during very hot or cold temperatures.
Bluetooth audio does not stream.	This is a device-dependent feature.	Make sure you connect the device to SYNC and press play on your device.
	The device is not connected.	
SYNC does not recognize music that is on my device.	Your music files may not contain the correct artist, song title, album or genre information.	Make sure that all song details are populated.
	The file may be corrupted.	Try replacing the corrupt file with a new version.
	The song may have copyright protection that does not allow it to play.	Some devices require you to change the USB settings from mass storage to media transfer protocol class.

SYNC™ 2

USB and media issues		
Issue	Possible cause	Possible solution
When I connect my iPhone or iPod Touch through the USB and Bluetooth Audio at the same time, I sometimes do not hear any sound.	This is a device limitation.	From the iPhone or iPod Touch music now playing screen, select the audio device airplay icon at the very bottom of your iPhone or iPod Touch screen.
		To listen to the iPhone or iPod Touch through Bluetooth Audio, select SYNC.
		To listen to the iPhone or iPod Touch through USB, select Dock Connector.

Voice command issues		
Issue	Possible cause	Possible solution
SYNC does not understand what I am saying.	You may be using the wrong voice commands.	Review the mobile phone voice commands and the media voice commands at the beginning of their respective sections.
		Refer to the audio display during an active voice session to find a list of voice commands there.
	You may be speaking too soon or at the wrong time.	Start speaking when the second SYNC tone sounds and the system is ready for voice input.
	You may not be speaking into the microphone	Make sure you speak into the microphone. It is located in the headliner just above the windshield.
SYNC does not understand the name of a song or artist.	You may be using the wrong voice commands.	Review the media voice commands at the beginning of the media section.
	You may not be saying the name exactly as the system saved it.	Say the song or artist exactly as the system saved it. If you say, "Play Artist Prince", the system does not play music by Prince and the Revolution or Prince and the New Power Generation.
		Make sure you are saying the complete title such as "California remix featuring Jennifer Nettles".

SYNC™ 2

Voice command issues		
Issue	Possible cause	Possible solution
		If the song titles are in capital letters, you have to spell them. LOLA requires you to say "L-O-L-A".
	The system may not be reading the name the same way you are saying it.	Try to avoid using special characters as the system does not recognize them.
SYNC does not understand or is calling the wrong contact when I want to make a call.	You may be using the wrong voice commands.	Review the mobile phone voice commands at the beginning of the mobile phone section.
		You can also use the mobile phone and media suggestion lists to get a list of possible suggestions when the system cannot fully understand you.
	You may not be saying the name exactly as the system saved it.	Make sure you are saying the name exactly as the system saved it. For example, if the contact name is Joe Wilson, say "Call Joe Wilson".
		The system works better if you list full names such as "Joe Wilson" rather than "Joe".
	Contacts in your phonebook may be very short and similar or they may contain special characters.	Try to avoid using special characters as the system does not recognize them.
Your phonebook contacts may be in capital letters.	If the contacts are in capital letters, you have to spell them. JAKE requires you to say "Call J-A-K-E".	
The SYNC voice control system is having trouble recognizing foreign names stored on my mobile phone.	You may be saying the foreign names using the currently selected language for SYNC.	SYNC applies the phonetic pronunciation rules of the selected language to the contact names stored on your mobile phone.

SYNC™ 2

Voice command issues		
Issue	Possible cause	Possible solution
		<p>Helpful Hint: You can select your contact manually. Press PHONE. Select the option for phonebook and then contact name. Press the soft-key option to hear it. SYNC will read the contact name to you, giving you some idea of the pronunciation it is expecting.</p>
<p>The SYNC voice control system is having trouble recognizing foreign tracks, artists, albums, genres and playlist names from my media player or USB flash drive.</p>	<p>You may be saying the foreign names using the currently selected language for SYNC.</p>	<p>SYNC applies the phonetic pronunciation rules of the selected language to the names stored on your media player or USB flash drive. It is able to make some exceptions for very popular artist names (for example, U2) such that you can always use the English pronunciation for these artists.</p>
<p>The system generates voice prompts and the pronunciation of some words may not be accurate for my language.</p>	<p>SYNC uses text-to-speech voice prompt technology.</p>	<p>SYNC uses a synthetically generated voice rather than pre-recorded human voice.</p>
		<p>SYNC offers several new voice control features for a wide range of languages. Dialing a contact name directly from the phonebook without pre-recording (for example, "call John Smith") or selecting a track, artist, album, genre or playlist directly from your media player (for example, "play artist Madonna").</p>

SYNC™ 2

General		
Issue	Possible cause	Possible solution
The language selected for the instrument cluster and information and entertainment display does not match the SYNC language (phone, USB, Bluetooth audio, voice control and voice prompts).	SYNC does not support the currently selected language for the instrument cluster and information and entertainment display.	SYNC only supports four languages in a single module for text display, voice control and voice prompts. The country where you bought your vehicle dictates the four languages based on the most popular languages spoken. If the selected language is not available, SYNC remains in the current active language.
		SYNC offers several new voice control features for a wide range of languages. Dialing a contact name directly from the phonebook without pre-recording (for example, "call John Smith") or selecting a track, artist, album, genre or playlist directly from your media player (for example, "play artist Madonna").

SYNC with Touchscreen System Reset
The system has a System Reset feature that can be performed if the function of your Sync unit is lost. This reset is intended to restore functionality and will not erase any information previously stored in the system (such as paired devices, phonebook, call history, text messages, or user settings). To perform a System Reset, press and hold the Seek Up (>>) button while pressing and holding the Radio Power button. After approximately 5 seconds the screen will go black. Allow a 1-2 minutes for the system reset to complete. You may then resume using the SYNC system.





Appendices

ELECTROMAGNETIC COMPATIBILITY

WARNINGS

 Your vehicle has been tested and certified to legislations relating to electromagnetic compatibility (72/245/EEC, UN ECE Regulation 10 or other applicable local requirements). It is your responsibility to make sure that any equipment you have fitted complies with applicable local legislations. Have any equipment fitted by an authorized dealer.

WARNINGS

-  The radio frequency transmitter equipment, for example cellular telephones and amateur radio transmitters, may only be fitted to your vehicle if they keep to the parameters shown in the table below. There are no special provisions or conditions for installations or use.
-  Do not mount any transceiver, microphones, speakers, or any other item in the deployment path of the airbag system.
-  Do not fasten antenna cables to original vehicle wiring, fuel pipes and brake pipes.
-  Keep antenna and power cables at least 10 cm from any electronic modules and airbags.

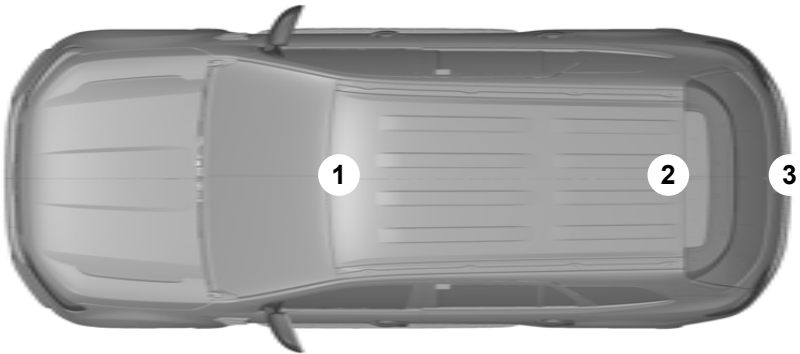

E199929

Appendices

Frequency Band MHz	Maximum output power Watt (Peak RMS)	Antenna Positions
1-30	100 W	3
50-54	100 W	1
68-87.5	50 W	1
142-176	50 W	1
220-225	50 W	1
380-512	50 W	1
806-940	10 W	1
1200-1400	10 W	1
1710-1885	10 W	1
1885-2025	10 W	1

Note: After the installation of radio frequency transmitters, check for disturbances from and to all electrical equipment in your vehicle, both in the standby and transmit modes.

Check all electrical equipment:

- With the ignition on.
- With the engine running.
- During a road test at various speeds.

Check that electromagnetic fields generated inside your vehicle cabin by the transmitter installed do not exceed applicable human exposure requirements.

TYPE APPROVALS

RF Certification Logos

Brazil



E207816

Argentina



E207817

Abu Dhabi, Dubai

Appendices



E197509



E202555

Brazil

Herby, Schrader Electronics UK Ltd., declares that this TPMS is in compliance with the essential requirements and other provisions of directive 1999/5/EC. The declaration of conformity may be consulted at emcteam@schrader.co.uk

E207818

European Union EU

European Union



E212162

Herby, Schrader Electronics UK Ltd., declares that this TPMS is in compliance with the essential requirements and other provisions of directive 1999/5/EC. The declaration of conformity may be consulted at emcteam@schrader.co.uk

E207818

Jordan

Kingdom of Jordan Type approval for tyre pressure sensor.
Model: AG2SZ4
Manufacturer: Schrader Electronics
Type Approval Number: TRC/LPD/2014/56

E207819

RAQP/33A/0514/S/(14-0847)

E207820

Malaysia

Appendices



E197811
Moldova

Complies with
IDA Standards
DA 00461

E207822
Singapore

AGREE PAR L'ANRT MAROC
Numéro d'agrément: MR9098
ANRT 2014
Date d'agrément: 14/03/2014

E207821
Morocco



TA-2014/064
Approved

E198002
South Africa



Type Approved

NTC

No:ESD-1408639C

E198001
Philippines



E203899



E197844
Serbia

Appendices



E203679

Taiwan



Schrader Electronics цім стверджує, що обладнання Радіопередавач моделі AG2S24 системи контролю тиску в шині автомобіля відповідає вимогам Технічного регламенту радіобладнання і телекомунікаційного кінцевого (термінального) обладнання (Постанова РММУ № 679 від 24 червня 2009 р.) Декларація відповідності знаходиться на сайті Schrader

Electronics та надається за запитом на електронну адресу doc.request@schrader.co.uk E198009

Bluetooth

The Bluetooth word mark and logos are owned by the Bluetooth SIG, Inc. and any use of such marks by Ford Motor Company is under license. Other trademarks and trade names are those of their respective owners.

iPod

iPod is a trademark of Apple Inc.

SD Card



SD Logo is a trademark.

END USER LICENSE AGREEMENT

SYNC™ End User License Agreement (EULA)

- You have acquired a device ("DEVICE") that includes software licensed by FORD MOTOR COMPANY from an affiliate of Microsoft Corporation ("MS"). Those installed software products of MS origin, as well as associated media, printed materials,

Appendices

and "online" or electronic documentation ("MS SOFTWARE") are protected by international intellectual property laws and treaties. The MS SOFTWARE is licensed, not sold. All rights reserved.T

- The MS SOFTWARE may interface with and/or communicate with, or may be later upgraded to interface with and/or communicate with additional software and/or systems provided by FORD MOTOR COMPANY. The additional software and systems of FORD MOTOR COMPANY origin, as well as associated media, printed materials, and "online" or electronic documentation ("FORD SOFTWARE") are protected by international intellectual property laws and treaties. The FORD SOFTWARE is licensed, not sold. All rights reserved.
- The MS SOFTWARE and/or FORD SOFTWARE may interface with and/or communicate with, or may be later upgraded to interface with and/or communicate with additional software and/or systems provided by third party software and service suppliers. The additional software and services of third party origin, as well as associated media, printed materials, and "online" or electronic documentation ("THIRD PARTY SOFTWARE") are protected by international intellectual property laws and treaties. The THIRD PARTY SOFTWARE is licensed, not sold. All rights reserved.
- The MS SOFTWARE, FORD SOFTWARE and THIRD PARTY SOFTWARE hereinafter collectively and individually will be referred to as "SOFTWARE".

IF YOU DO NOT AGREE TO THIS END USER LICENSE AGREEMENT ("EULA") DO NOT USE THE DEVICE OR COPY THE SOFTWARE. ANY USE OF THE SOFTWARE, INCLUDING BUT NOT LIMITED TO USE ON THE DEVICE, WILL CONSTITUTE YOUR AGREEMENT TO THIS EULA (OR RATIFICATION OF ANY PREVIOUS CONSENT).

GRANT OF SOFTWARE LICENSE: This EULA grants you the following license:

- You may use the SOFTWARE as installed on the DEVICE and as otherwise interfacing with systems and/or services provide by or through FORD MOTOR COMPANY or its third party software and service providers.

Description of Other Rights and Limitations

- **Speech Recognition:** If the SOFTWARE includes speech recognition component(s), you should understand that speech recognition is an inherently statistical process and that recognition errors are inherent in the process. Neither FORD MOTOR COMPANY nor its suppliers shall be liable for any damages arising out of errors in the speech recognition process.
- **Limitations on Reverse Engineering, Decompile and Disassembly:** You may not reverse engineer, decompile, or disassemble nor permit others to reverse engineer, decompile or disassemble the SOFTWARE, except and only to the extent that such activity is expressly permitted by applicable law notwithstanding this limitation.

Appendices

- **Limitations on Distributing, Copying, Modifying and Creating Derivative Works:** You may not distribute, copy, make modifications to or create derivative works based on the SOFTWARE, except and only to the extent that such activity is expressly permitted by applicable law notwithstanding this limitation.
- **Single EULA:** The end user documentation for the DEVICE and related systems and services may contain multiple EULAs, such as multiple translations and/or multiple media versions (e.g., in the user documentation and in the software). Even if you receive multiple EULAs, you are licensed to use only one (1) copy of the SOFTWARE.
- **SOFTWARE Transfer:** You may permanently transfer your rights under this EULA only as part of a sale or transfer of the DEVICE, provided you retain no copies, you transfer all of the SOFTWARE (including all component parts, the media and printed materials, any upgrades, and, if applicable, the Certificate(s) of Authenticity), and the recipient agrees to the terms of this EULA. If the SOFTWARE is an upgrade, any transfer must include all prior versions of the SOFTWARE.
- **Termination:** Without prejudice to any other rights, FORD MOTOR COMPANY or MS may terminate this EULA if you fail to comply with the terms and conditions of this EULA.
- **Security Updates/Digital Rights Management:** Content owners use the WMDRM technology included in your DEVICE to protect their intellectual property, included copyrighted content. Portions of the SOFTWARE on your DEVICE use WMDRM software to access WMDRM-protected content. If the WMDRM software fails to protect the content, content owners may ask Microsoft to revoke the SOFTWARE's ability to use WMDRM to play or copy protected content. This action does not affect unprotected content. When your DEVICE downloads licenses for protected content, you agree that Microsoft may include a revocation list with the licenses. Content owners may require you to upgrade the SOFTWARE on your DEVICE to access their content. If you decline an upgrade, you will not be able to access content that requires the upgrade.
- **Consent to Use of Data:** You agree that MS, Microsoft Corporation, FORD MOTOR COMPANY, third party software and systems suppliers, their affiliates and/or their designated agent may collect and use technical information gathered in any manner as part of product support services related to the SOFTWARE or related services. MS, Microsoft Corporation, FORD MOTOR COMPANY, third party software and services suppliers, their affiliates and/or their designated agent may use this information solely to improve their products or to provide customized services or technologies to you. MS, Microsoft Corporation, FORD MOTOR COMPANY, third party software and systems suppliers, their affiliates and/or their designated agent may disclose this information to others, but not in a form that personally identifies you.

Appendices

- **Internet-Based Services Components:** The SOFTWARE may contain components that enable and facilitate the use of certain Internet-based services. You acknowledge and agree that MS, Microsoft Corporation, FORD MOTOR COMPANY, third party software and service suppliers, their affiliates and/or their designated agent may automatically check the version of the SOFTWARE and/or its components that you are utilizing and may provide upgrades or supplements to the SOFTWARE that may be automatically downloaded to your DEVICE.
- **Additional Software/Services:** The SOFTWARE may permit FORD MOTOR COMPANY, third party software and service suppliers, MS, Microsoft Corporation, their affiliates and/or their designated agent to provide or make available to you SOFTWARE updates, supplements, add-on components, or Internet-based services components of the SOFTWARE after the date you obtain your initial copy of the SOFTWARE ("Supplemental Components").

If FORD MOTOR COMPANY or third party software and services suppliers provide or make available to you Supplemental Components and no other EULA terms are provided along with the Supplemental Components, then the terms of this EULA shall apply.

If MS, Microsoft Corporation, their affiliates and/or their designated agent make available Supplemental Components, and no other EULA terms are provided, then the terms of this EULA shall apply, except that the MS, Microsoft Corporation or affiliate entity providing the Supplemental Component(s) shall be the licensor of the Supplemental Component(s).

FORD MOTOR COMPANY, MS, Microsoft Corporation, their affiliates and/or their designated agent reserve the right to discontinue without liability any Internet-based services provided to you or made available to you through the use of the SOFTWARE.

- **Links to Third Party Sites:** The MS SOFTWARE may provide you with the ability to link to third party sites through the use of the SOFTWARE. The third party sites are not under the control of MS, Microsoft Corporation, their affiliates and/or their designated agent. Neither MS nor Microsoft Corporation nor their affiliates nor their designated agent are responsible for (i) the contents of any third party sites, any links contained in third party sites, or any changes or updates to third party sites, or (ii) webcasting or any other form of transmission received from any third party sites. If the SOFTWARE provides links to third party sites, those links are provided to you only as a convenience, and the inclusion of any link does not imply an endorsement of the third party site by MS, Microsoft Corporation, their affiliates and/or their designated agent.
- **Obligation to Drive Responsibly:** You recognize your obligation to drive responsibly and keep attention on the road. You will read and abide with the DEVICE operating instructions particularly as they pertain to safety and assumes any risk associated with the use of the DEVICE.

UPGRADES AND RECOVERY MEDIA: If the SOFTWARE is provided by FORD MOTOR COMPANY separate from the DEVICE on media such as a ROM chip, CD ROM disk(s) or via web download or other means, and is labeled "For Upgrade Purposes Only" or "For Recovery Purposes Only" you may install one (1) copy of such

Appendices

SOFTWARE onto the DEVICE as a replacement copy for the existing SOFTWARE, and use it in accordance with this EULA, including any additional EULA terms accompanying the upgrade SOFTWARE.

INTELLECTUAL PROPERTY RIGHTS:

All title and intellectual property rights in and to the SOFTWARE (including but not limited to any images, photographs, animations, video, audio, music, text and "applets" incorporated into the SOFTWARE), the accompanying printed materials, and any copies of the SOFTWARE, are owned by MS, Microsoft Corporation, FORD MOTOR COMPANY, or their affiliates or suppliers. The SOFTWARE is licensed, not sold. You may not copy the printed materials accompanying the SOFTWARE. All title and intellectual property rights in and to the content which may be accessed through use of the SOFTWARE is the property of the respective content owner and may be protected by applicable copyright or other intellectual property laws and treaties. This EULA grants you no rights to use such content. All rights not specifically granted under this EULA are reserved by MS, Microsoft Corporation, FORD MOTOR COMPANY, third party software and service providers, their affiliates and suppliers. Use of any on-line services which may be accessed through the SOFTWARE may be governed by the respective terms of use relating to such services. If this SOFTWARE contains documentation that is provided only in electronic form, you may print one copy of such electronic documentation.

EXPORT RESTRICTIONS: You acknowledge that the SOFTWARE is subject to U.S. and European Union export jurisdiction. You agree to comply with all applicable international and national laws that apply to the SOFTWARE, including

the U.S. Export Administration Regulations, as well as end-user, end-use and destination restrictions issued by U.S. and other governments. For additional information, see <http://www.microsoft.com/exporting/>.

TRADEMARKS: This EULA does not grant you any rights in connection with any trademarks or service marks of FORD MOTOR COMPANY, MS, Microsoft Corporation, third party software or service providers, their affiliates or suppliers.

PRODUCT SUPPORT: Product support for the SOFTWARE is not provided by MS, its parent corporation Microsoft Corporation, or their affiliates or subsidiaries. For product support, please refer to FORD MOTOR COMPANY instructions provided in the documentation for the DEVICE. Should you have any questions concerning this EULA, or if you desire to contact FORD MOTOR COMPANY for any other reason, please refer to the address provided in the documentation for the DEVICE.

No Liability for Certain Damages:

EXCEPT AS PROHIBITED BY LAW, FORD MOTOR COMPANY, ANY THRID PARTY SOFTWARE OR SERVICES SUPPLIERS, MS, MICROSOFT CORPORATION AND THEIR AFFILIATES SHALL HAVE NO LIABILITY FOR ANY INDIRECT, SPECIAL, CONSEQUENTIAL OR INCIDENTAL DAMAGES ARISING FROM OR IN CONNECTION WITH THE USE OR PERFORMANCE OF THE SOFTWARE. THIS LIMITATION SHALL APPLY EVEN IF ANY REMEDY FAILS OF ITS ESSENTIAL PURPOSE. IN NO EVENT SHALL MS, MICROSOFT CORPORATION AND/OR THEIR AFFILIATES BE LIABLE FOR ANY AMOUNT IN EXCESS OF U.S. TWO HUNDRED FIFTY DOLLARS (U.S. \$250.00).

Appendices

- THERE ARE NO WARRANTIES OTHER THAN THOSE THAT MAY EXPRESSLY BE PROVIDED FOR YOUR NEW VEHICLE.

End User Notice

Microsoft® Windows® Mobile for Automotive Important Safety Information

This system Ford SYNC contains software that is licensed to Manufacturer FORD MOTOR COMPANY by an affiliate of Microsoft Corporation pursuant to a license agreement. Any removal, reproduction, reverse engineering or other unauthorized use of the software from this system in violation of the license agreement is strictly prohibited and may subject you to legal action.

Read and follow instructions: Before using your Windows Automotive-based system, read and follow all instructions and safety information provided in this end user manual ("User's Guide"). Not following precautions found in this User's Guide can lead to an accident or other serious consequences.

Keep User's Guide in vehicle: When kept in the vehicle, the User's Guide will be a ready reference for you and other users unfamiliar with the Windows Automotive-based system. Please make certain that before using the system for the first time, all persons have access to the User's Guide and read its instructions and safety information carefully.

WARNING



Operating certain parts of this system while driving can distract your attention away from the road, and possibly cause an accident or other serious consequences. Do not change system settings or enter data non-verbally (using your hands) while driving. Stop the vehicle in a safe and legal manner before attempting these operations. This is important since while setting up or changing some functions you might be required to distract your attention away from the road and remove your hands from the wheel.

General Operation

Voice Command Control: Functions within the Windows Automotive-based system may be accomplished using only voice commands. Using voice commands while driving allows you to operate the system without removing your hands from the wheel.

Prolonged Views of Screen: Do not access any function requiring a prolonged view of the screen while you are driving. Pull over in a safe and legal manner before attempting to access a function of the system requiring prolonged attention. Even occasional short scans to the screen may be hazardous if your attention has been diverted away from your driving task at a critical time.

Volume Setting: Do not raise the volume excessively. Keep the volume at a level where you can still hear outside traffic and emergency signals while driving. Driving while unable to hear these sounds could cause an accident.

Appendices

Use of Speech Recognition Functions:

Speech recognition software is inherently a statistical process which is subject to errors. It is your responsibility to monitor any speech recognition functions included in the system and address any errors.

END USER LICENSE AGREEMENT

SYNC / SYNC2 End User License Agreement (EULA)

- You have acquired a device ("DEVICE") that includes software licensed by Ford Motor Company and its affiliates ("FORD MOTOR COMPANY") from an affiliate of Microsoft Corporation ("MS") . Those installed software products of MS origin, as well as associated media, printed materials, and "online" or electronic documentation ("MS SOFTWARE") are protected by international intellectual property laws and treaties. The MS SOFTWARE is licensed, not sold. All rights reserved.
- The MS SOFTWARE may interface with and/or communicate with, or may be later upgraded to interface with and/or communicate with additional software and/or systems provided by FORD MOTOR COMPANY. The additional software and systems of FORD MOTOR COMPANY origin, as well as associated media, printed materials, and "online" or electronic documentation ("FORD SOFTWARE") are protected by international intellectual property laws and treaties. The FORD SOFTWARE is licensed, not sold. All rights reserved.

- The MS SOFTWARE and/or FORD SOFTWARE may interface with and/or communicate with, or may be later upgraded to interface with and/or communicate with additional software and/or systems provided by third party software and service suppliers. The additional software and services of third party origin, as well as associated media, printed materials, and "online" or electronic documentation ("THIRD PARTY SOFTWARE") are protected by international intellectual property laws and treaties. The THIRD PARTY SOFTWARE is licensed, not sold. All rights reserved.
- The MS SOFTWARE, FORD SOFTWARE and THIRD PARTY SOFTWARE hereinafter collectively and individually will be referred to as "SOFTWARE".

IF YOU DO NOT AGREE TO THIS END USER LICENSE AGREEMENT ("EULA") DO NOT USE THE DEVICE OR COPY THE SOFTWARE. ANY USE OF THE SOFTWARE, INCLUDING BUT NOT LIMITED TO USE ON THE DEVICE, WILL CONSTITUTE YOUR AGREEMENT TO THIS EULA (OR RATIFICATION OF ANY PREVIOUS CONSENT).

GRANT OF SOFTWARE LICENSE: This EULA grants you the following license:

- You may use the SOFTWARE as installed on the DEVICE and as otherwise interfacing with systems and/or services provide by or through FORD MOTOR COMPANY or its third party software and service providers.

Appendices

Description of Other Rights and Limitations

- **Speech Recognition:** If the SOFTWARE includes speech recognition component(s), you should understand that speech recognition is an inherently statistical process and that recognition errors are inherent in the process. Neither FORD MOTOR COMPANY nor its suppliers shall be liable for any damages arising out of errors in the speech recognition process.
- **Limitations on Reverse Engineering, Decompilation and Disassembly:** You may not reverse engineer, decompile, or disassemble nor permit others to reverse engineer, decompile or disassemble the SOFTWARE, except and only to the extent that such activity is expressly permitted by applicable law notwithstanding this limitation.
- **Limitations on Distributing, Copying, Modifying and Creating Derivative Works:** You may not distribute, copy, make modifications to or create derivative works based on the SOFTWARE, except and only to the extent that such activity is expressly permitted by applicable law notwithstanding this limitation.
- **Single EULA:** The end user documentation for the DEVICE and related systems and services may contain multiple EULAs, such as multiple translations and/or multiple media versions (e.g., in the user documentation and in the software). Even if you receive multiple EULAs, you are licensed to use only one (1) copy of the SOFTWARE.
- **SOFTWARE Transfer:** You may permanently transfer your rights under this EULA only as part of a sale or transfer of the DEVICE, provided you retain no copies, you transfer all of the SOFTWARE (including all component parts, the media and printed materials, any upgrades, and, if applicable, the Certificate(s) of Authenticity), and the recipient agrees to the terms of this EULA. If the SOFTWARE is an upgrade, any transfer must include all prior versions of the SOFTWARE.
- **Termination:** Without prejudice to any other rights, FORD MOTOR COMPANY or MS may terminate this EULA if you fail to comply with the terms and conditions of this EULA.
- **Security Updates/Digital Rights Management:** Content owners use the WMDRM technology included in your DEVICE to protect their intellectual property, included copyrighted content. Portions of the SOFTWARE on your DEVICE use WMDRM software to access WMDRM-protected content. If the WMDRM software fails to protect the content, content owners may ask Microsoft to revoke the SOFTWARE's ability to use WMDRM to play or copy protected content. This action does not affect unprotected content. When your DEVICE downloads licenses for protected content, you agree that Microsoft may include a revocation list with the licenses. Content owners may require you to upgrade the SOFTWARE on your DEVICE to access their content. If you decline an upgrade, you will not be able to access content that requires the upgrade.

Appendices

- **Consent to Use of Data:** You agree that MS, Microsoft Corporation, FORD MOTOR COMPANY, third party software and systems suppliers, their affiliates and/or their designated agent may collect and use technical information gathered in any manner as part of product support services related to the SOFTWARE or related services. MS, Microsoft Corporation, FORD MOTOR COMPANY, third party software and services suppliers, their affiliates and/or their designated agent may use this information solely to improve their products or to provide customized services or technologies to you. MS, Microsoft Corporation, FORD MOTOR COMPANY, third party software and systems suppliers, their affiliates and/or their designated agent may disclose this information to others, but not in a form that personally identifies you.
- **Internet-Based Services Components:** The SOFTWARE may contain components that enable and facilitate the use of certain Internet-based services. You acknowledge and agree that MS, Microsoft Corporation, FORD MOTOR COMPANY, third party software and service suppliers, their affiliates and/or their designated agent may automatically check the version of the SOFTWARE and/or its components that you are utilizing and may provide upgrades or supplements to the SOFTWARE that may be automatically downloaded to your DEVICE.
- **Additional Software/Services:** The SOFTWARE may permit FORD MOTOR COMPANY, third party software and service suppliers, MS, Microsoft Corporation, their affiliates and/or their designated agent to provide or make available to you SOFTWARE updates,

supplements, add-on components, or Internet-based services components of the SOFTWARE after the date you obtain your initial copy of the SOFTWARE ("Supplemental Components").

If FORD MOTOR COMPANY or third party software and services suppliers provide or make available to you Supplemental Components and no other EULA terms are provided along with the Supplemental Components, then the terms of this EULA shall apply.

If MS, Microsoft Corporation, their affiliates and/or their designated agent make available Supplemental Components, and no other EULA terms are provided, then the terms of this EULA shall apply, except that the MS, Microsoft Corporation or affiliate entity providing the Supplemental Component(s) shall be the licensor of the Supplemental Component(s).

FORD MOTOR COMPANY, MS, Microsoft Corporation, their affiliates and/or their designated agent reserve the right to discontinue without liability any Internet-based services provided to you or made available to you through the use of the SOFTWARE.

Appendices

- **Links to Third Party Sites:** The MS SOFTWARE may provide you with the ability to link to third party sites through the use of the SOFTWARE. The third party sites are not under the control of MS, Microsoft Corporation, their affiliates and/or their designated agent. Neither MS nor Microsoft Corporation nor their affiliates nor their designated agent are responsible for (i) the contents of any third party sites, any links contained in third party sites, or any changes or updates to third party sites, or (ii) webcasting or any other form of transmission received from any third party sites. If the SOFTWARE provides links to third party sites, those links are provided to you only as a convenience, and the inclusion of any link does not imply an endorsement of the third party site by MS, Microsoft Corporation, their affiliates and/or their designated agent.
- **Obligation to Drive Responsibly:** You recognize your obligation to drive responsibly and keep attention on the road. You will read and abide with the DEVICE operating instructions particularly as they pertain to safety and assumes any risk associated with the use of the DEVICE.

UPGRADES AND RECOVERY MEDIA:

If the SOFTWARE is provided by FORD MOTOR COMPANY separate from the DEVICE on media such as a ROM chip, CD ROM disk(s) or via web download or other means, and is labeled "For Upgrade Purposes Only" or "For Recovery Purposes Only" you may install one (1) copy of such SOFTWARE onto the DEVICE as a replacement copy for the existing SOFTWARE, and use it in accordance with this EULA, including any additional EULA terms accompanying the upgrade SOFTWARE.

INTELLECTUAL PROPERTY RIGHTS:

All title and intellectual property rights in and to the SOFTWARE (including but not limited to any images, photographs, animations, video, audio, music, text and "applets" incorporated into the SOFTWARE), the accompanying printed materials, and any copies of the SOFTWARE, are owned by MS, Microsoft Corporation, FORD MOTOR COMPANY, or their affiliates or suppliers. The SOFTWARE is licensed, not sold. You may not copy the printed materials accompanying the SOFTWARE. All title and intellectual property rights in and to the content which may be accessed through use of the SOFTWARE is the property of the respective content owner and may be protected by applicable copyright or other intellectual property laws and treaties. This EULA grants you no rights to use such content. All rights not specifically granted under this EULA are reserved by MS, Microsoft Corporation, FORD MOTOR COMPANY, third party software and service providers, their affiliates and suppliers. Use of any on-line services which may be accessed through the SOFTWARE may be governed by the respective terms of use relating to such services. If this SOFTWARE contains documentation that is provided only in electronic form, you may print one copy of such electronic documentation.

EXPORT RESTRICTIONS: You acknowledge that the SOFTWARE is subject to U.S. and European Union export jurisdiction. You agree to comply with all applicable international and national laws that apply to the SOFTWARE, including the U.S. Export Administration Regulations, as well as end-user, end-use and destination restrictions issued by U.S. and other governments. For additional information, see <http://www.microsoft.com/exporting/>.

Appendices

TRADEMARKS: This EULA does not grant you any rights in connection with any trademarks or service marks of FORD MOTOR COMPANY, MS, Microsoft Corporation, third party software or service providers, their affiliates or suppliers.

PRODUCT SUPPORT: Product support for the SOFTWARE is not provided by MS, its parent corporation Microsoft Corporation, or their affiliates or subsidiaries. For product support, please refer to FORD MOTOR COMPANY instructions provided in the documentation for the DEVICE. Should you have any questions concerning this EULA, or if you desire to contact FORD MOTOR COMPANY for any other reason, please refer to the address provided in the documentation for the DEVICE.

No Liability for Certain Damages: EXCEPT AS PROHIBITED BY LAW, FORD MOTOR COMPANY, ANY THIRD PARTY SOFTWARE OR SERVICES SUPPLIERS, MS, MICROSOFT CORPORATION AND THEIR AFFILIATES SHALL HAVE NO LIABILITY FOR ANY INDIRECT, SPECIAL, CONSEQUENTIAL OR INCIDENTAL DAMAGES ARISING FROM OR IN CONNECTION WITH THE USE OR PERFORMANCE OF THE SOFTWARE. THIS LIMITATION SHALL APPLY EVEN IF ANY REMEDY FAILS OF ITS ESSENTIAL PURPOSE. IN NO EVENT SHALL MS, MICROSOFT CORPORATION AND/OR THEIR AFFILIATES BE LIABLE FOR ANY AMOUNT IN EXCESS OF U.S. TWO HUNDRED FIFTY DOLLARS (U.S. \$250.00).

- THERE ARE NO WARRANTIES OTHER THAN THOSE THAT MAY EXPRESSLY BE PROVIDED FOR YOUR NEW VEHICLE.

Adobe

Contains Adobe® [Flash® Player] or [AIR®] technology by Adobe Systems Incorporated. This [Licensee Product] contains [Adobe® Flash® Player] [Adobe® AIR®] software under license from Adobe Systems Incorporated, Copyright ©1995-2009 Adobe Macromedia Software LLC. All rights reserved. Adobe, Flash and AIR are trademarks of Adobe Systems Incorporated.

End User Notice

Microsoft® Windows® Mobile for Automotive Important Safety Information

This system Ford SYNC contains software that is licensed to Manufacturer FORD MOTOR COMPANY by an affiliate of Microsoft Corporation pursuant to a license agreement. Any removal, reproduction, reverse engineering or other unauthorized use of the software from this system in violation of the license agreement is strictly prohibited and may subject you to legal action.

Read and follow instructions: Before using your Windows Automotive- based system, read and follow all instructions and safety information provided in this end user manual ("User's Guide"). Not following precautions found in this User's Guide can lead to an accident or other serious consequences.

Keep User's Guide in vehicle: When kept in the vehicle, the User's Guide will be a ready reference for you and other users unfamiliar with the Windows Automotive-based system. Please make certain that before using the system for the first time, all persons have access to the User's Guide and read its instructions and safety information carefully.

Appendices

WARNING



Operating certain parts of this system while driving can distract your attention away from the road, and possibly cause an accident or other serious consequences. Do not change system settings or enter data non-verbally (using your hands) while driving. Stop the vehicle in a safe and legal manner before attempting these operations. This is important since while setting up or changing some functions you might be required to distract your attention away from the road and remove your hands from the wheel.

General Operation

Voice Command Control: Functions within the Windows Automotive-based system may be accomplished using only voice commands. Using voice commands while driving allows you to operate the system without removing your hands from the wheel.

Prolonged Views of Screen: Do not access any function requiring a prolonged view of the screen while you are driving. Pull over in a safe and legal manner before attempting to access a function of the system requiring prolonged attention. Even occasional short scans to the screen may be hazardous if your attention has been diverted away from your driving task at a critical time.

Volume Setting: Do not raise the volume excessively. Keep the volume at a level where you can still hear outside traffic and emergency signals while driving. Driving while unable to hear these sounds could cause an accident.

Use of Speech Recognition Functions:

Speech recognition software is inherently a statistical process which is subject to errors. It is your responsibility to monitor any speech recognition functions included in the system and address any errors.

Navigation Features: Any navigation features included in the system are intended to provide turn by turn instructions to get you to a desired destination. Please make certain all persons using this system carefully read and follow instructions and safety information fully.

Distraction Hazard: Any navigation features may require manual (non-verbal) setup. Attempting to perform such set-up or insert data while driving can seriously distract your attention and could cause an accident or other serious consequences. Stop the vehicle in a safe and legal manner before attempting these operations.

Let Your Judgment Prevail: Any navigation features are provided only as an aid. Make your driving decisions based on your observations of local conditions and existing traffic regulations. Any such feature is not a substitute for your personal judgment. Any route suggestions made by this system should never replace any local traffic regulations or your personal judgment or knowledge of safe driving practices.

Route Safety: Do not follow the route suggestions if doing so would result in an unsafe or illegal maneuver, if you would be placed in an unsafe situation, or if you would be directed into an area that you consider unsafe. The driver is ultimately responsible for the safe operation of the vehicle and therefore, must evaluate whether it is safe to follow the suggested directions.

Appendices

Potential Map Inaccuracy: Maps used by this system may be inaccurate because of changes in roads, traffic controls or driving conditions. Always use good judgment and common sense when following the suggested routes.

Emergency Services: Do not rely on any navigation features included in the system to route you to emergency services. Ask local authorities or an emergency services operator for these locations. Not all emergency services such as police, fire stations, hospitals and clinics are likely to be contained in the map database for such navigation features.

Telenav Software End User License Agreement

Please read these terms and conditions carefully before you use the Telenav Software. Your use of the Telenav Software indicates that you accept these terms and conditions. If you do not accept these terms and conditions, do not break the seal of the package, launch, or otherwise use the Telenav Software.

These terms and conditions represent the agreement ("Agreement") between you and Telenav, Inc. ("Telenav") with respect to the Telenav Software (including upgrades, modifications, or additions thereto) (collectively "Telenav Software"). All references herein to "you" and "your" means you, your employees, agents, and contractors, and any other entity on whose behalf you accept these terms and conditions, all of whom shall also be bound by this Agreement. Additionally, all of your account information, as well as other payment and personal information provided by you to Telenav (directly or through the use of the Telenav Software, is subject to Telenav's privacy policy located at <http://www.telenav.com>.

Telenav may revise this Agreement and the privacy policy at any time, with or without notice to you. You agree to visit <http://www.telenav.com> from time to time to review the then current version of this Agreement and of the privacy policy.

1. Safe and Lawful Use

You acknowledge that devoting attention to the Telenav Software may pose a risk of injury or death to you and others in situations that otherwise require your undivided attention, and you therefore agree to comply with the following when using the Telenav Software: (a) observe all traffic laws and otherwise drive safely; (b) use your own personal judgment while driving. If you feel that a route suggested by the Telenav Software instructs you to perform an unsafe or illegal maneuver, places you in an unsafe situation, or directs you into an area that you consider to be unsafe, do not follow such instructions; (c) do not input destinations, or otherwise manipulate the Telenav Software, unless your vehicle is stationary and parked; (d) do not use the Telenav Software for any illegal, unauthorized, unintended, unsafe, hazardous, or unlawful purposes, or in any manner inconsistent with this Agreement; (e) arrange all GPS and wireless devices and cables necessary for use of the Telenav Software in a secure manner in your vehicle so that they will not interfere with your driving and will not prevent the operation of any safety device (such as an airbag).

You agree to indemnify and hold Telenav harmless against all claims resulting from any dangerous or otherwise inappropriate use of the Telenav Software in any moving vehicle, including as a result of your failure to comply with the directions above.

Appendices

2. Account Information

You agree: (a) when registering the Telenav Software, to provide Telenav with true, accurate, current, and complete information about yourself, and (b) to inform Telenav promptly of any changes to such information, and to keep it true, accurate, current and complete.

3. Software License

Subject to your compliance with the terms of this Agreement, Telenav hereby grants to you a personal, non-exclusive, non-transferable license (except as expressly permitted below in connection with your permanent transfer of the Telenav Software license), without the right to sublicense, to use the Telenav Software (in object code form only) in order to access and use the Telenav Software. This license shall terminate upon any termination or expiration of this Agreement. You agree that you will use the Telenav Software only for your personal business or leisure purposes, and not to provide commercial navigation services to other parties.

3.1 License Limitations

You agree not to do any of the following: (a) reverse engineer, decompile, disassemble, translate, modify, alter or otherwise change the Telenav Software or any part thereof; (b) attempt to derive the source code, audio library or structure of the Telenav Software without the prior express written consent of Telenav; (c) remove from the Telenav Software, or alter, any of Telenav's or its suppliers' trademarks, trade names, logos, patent or copyright notices, or other notices or markings; (d) distribute, sublicense or otherwise transfer the Telenav Software to others, except as part of your permanent transfer of the Telenav Software; or (e) use the Telenav Software in any manner that (i) infringes the intellectual property

or proprietary rights, rights of publicity or privacy or other rights of any party, (ii) violates any law, statute, ordinance or regulation, including but not limited to laws and regulations related to spamming, privacy, consumer and child protection, obscenity or defamation, or (iii) is harmful, threatening, abusive, harassing, tortuous, defamatory, vulgar, obscene, libelous, or otherwise objectionable; and (f) lease, rent out, or otherwise permit unauthorized access by third parties to the Telenav Software without advanced written permission of Telenav.

4. Disclaimers

To the fullest extent permissible pursuant to applicable law, in no event will Telenav, its licensors and suppliers, or agents or employees of any of the foregoing, be liable for any decision made or action taken by you or anyone else in reliance on the information provided by the Telenav Software. Telenav also does not warrant the accuracy of the map or other data used for the Telenav Software. Such data may not always reflect reality due to, among other things, road closures, construction, weather, new roads and other changing conditions. You are responsible for the entire risk arising out of your use of the Telenav Software. For example but without limitation, you agree not to rely on the Telenav Software for critical navigation in areas where the well-being or survival of you or others is dependent on the accuracy of navigation, as the maps or functionality of the Telenav Software are not intended to support such high risk applications, especially in more remote geographical areas.

TELENAV EXPRESSLY DISCLAIMS AND EXCLUDES ALL WARRANTIES IN CONNECTION WITH THE TELENNAV SOFTWARE, WHETHER STATUTORY, EXPRESS OR IMPLIED, INCLUDING ALL WARRANTIES WHICH MAY ARISE FROM

Appendices

COURSE OF DEALING, CUSTOM OR TRADE AND INCLUDING, BUT NOT LIMITED TO, THE IMPLIED WARRANTIES OF MERCHANTABILITY, FITNESS FOR A PARTICULAR PURPOSE AND NON-INFRINGEMENT OF THIRD PARTY RIGHTS WITH RESPECT TO THE TELENV SOFTWARE. Certain jurisdictions do not permit the disclaimer of certain warranties, so this limitation may not apply to you.

5. Limitation of Liability

TO THE EXTENT PERMITTED UNDER APPLICABLE LAW, UNDER NO CIRCUMSTANCES SHALL TELENV OR ITS LICENSORS AND SUPPLIERS BE LIABLE TO YOU OR TO ANY THIRD PARTY FOR ANY INDIRECT, INCIDENTAL, CONSEQUENTIAL, SPECIAL OR EXEMPLARY DAMAGES (INCLUDING IN EACH CASE, BUT NOT LIMITED TO, DAMAGES FOR THE INABILITY TO USE THE EQUIPMENT OR ACCESS DATA, LOSS OF DATA, LOSS OF BUSINESS, LOSS OF PROFITS, BUSINESS INTERRUPTION OR THE LIKE) ARISING OUT OF THE USE OF OR INABILITY TO USE THE TELENV SOFTWARE, EVEN IF TELENV HAS BEEN ADVISED OF THE POSSIBILITY OF SUCH DAMAGES.

NOTWITHSTANDING ANY DAMAGES THAT YOU MIGHT INCUR FOR ANY REASON WHATSOEVER (INCLUDING, WITHOUT LIMITATION, ALL DAMAGES REFERENCED HEREIN AND ALL DIRECT OR GENERAL DAMAGES IN CONTRACT, TORT (INCLUDING NEGLIGENCE) OR OTHERWISE), THE ENTIRE LIABILITY OF TELENV AND OF ALL OF TELENV'S SUPPLIERS SHALL BE LIMITED TO THE AMOUNT ACTUALLY PAID BY YOU FOR THE TELENV SOFTWARE. SOME

STATES AND/OR JURISDICTIONS DO NOT ALLOW THE EXCLUSION OR LIMITATION OF INCIDENTAL OR CONSEQUENTIAL DAMAGES, SO THE ABOVE LIMITATIONS OR EXCLUSIONS MAY NOT APPLY TO YOU.

6. Arbitration and Governing Law

You agree that any dispute, claim or controversy arising out of or relating to this Agreement or the Telenav Software shall be settled by independent arbitration involving a neutral arbitrator and administered by the American Arbitration Association in the County of Santa Clara, California. The arbitrator shall apply the Commercial Arbitration Rules of the American Arbitration Association, and the judgment upon the award rendered by the arbitrator may be entered by any court having jurisdiction. Note that there is no judge or jury in an arbitration proceeding and the decision of the arbitrator shall be binding upon both parties. You expressly agree to waive your right to a jury trial.

This Agreement and performance hereunder will be governed by and construed in accordance with the laws of the State of California, without giving effect to its conflict of laws provisions. To the extent judicial action is necessary in connection with the binding arbitration, both Telenav and you agree to submit to the exclusive jurisdiction of the courts of the County of Santa Clara, California. The United Nations Convention on Contracts for the International Sale of Goods shall not apply.

7. Assignment

You may not resell, assign, or transfer this Agreement or any of your rights or obligations, except in totality, in connection with your permanent transfer of the Telenav Software, and expressly conditioned upon the new user of the Telenav Software agreeing to be bound by

Appendices

the terms and conditions of this Agreement. Any such sale, assignment or transfer that is not expressly permitted under this paragraph will result in immediate termination of this Agreement, without liability to Telenav, in which case you and all other parties shall immediately cease all use of the Telenav Software. Notwithstanding the foregoing, Telenav may assign this Agreement to any other party at any time without notice, provided the assignee remains bound by this Agreement.

8. Miscellaneous

8.1

This Agreement constitutes the entire agreement between Telenav and you with respect to the subject matter hereof.

8.2

Except for the limited licenses expressly granted in this Agreement, Telenav retains all right, title and interest in and to the Telenav Software, including without limitation all related intellectual property rights. No licenses or other rights which are not expressly granted in this Agreement are intended to, or shall be, granted or conferred by implication, statute, inducement, estoppel or otherwise, and Telenav and its suppliers and licensors hereby reserve all of their respective rights other than the licenses explicitly granted in this Agreement.

8.3

By using the Telenav Software, you consent to receive from Telenav all communications, including notices, agreements, legally required disclosures or other information in connection with the Telenav Software (collectively, "Notices") electronically. Telenav may provide such

Notices by posting them on Telenav's Website or by downloading such Notices to your wireless device. If you desire to withdraw your consent to receive Notices electronically, you must discontinue your use of the Telenav Software.

8.4

Telenav's or your failure to require performance of any provision shall not affect that party's right to require performance at any time thereafter, nor shall a waiver of any breach or default of this Agreement constitute a waiver of any subsequent breach or default or a waiver of the provision itself.

8.5

If any provision herein is held unenforceable, then such provision will be modified to reflect the intention of the parties, and the remaining provisions of this Agreement will remain in full force and effect.

8.6

The headings in this Agreement are for convenience of reference only, will not be deemed to be a part of this Agreement, and will not be referred to in connection with the construction or interpretation of this Agreement. As used in this Agreement, the words "include" and "including," and variations thereof, will not be deemed to be terms of limitation, but rather will be deemed to be followed by the words "without limitation."

9. Other Vendors Terms and Conditions

The Telenav Software utilizes map and other data licensed to Telenav by third party vendors for the benefit of you and other end users. This Agreement includes end-user terms applicable to these companies (included at the end of this

Appendices

Agreement), and thus your use of the Telenav Software is also subject to such terms. You agree to comply with the following additional terms and conditions, which are applicable to Telenav's third party vendor licensors:

9.1 End User Terms Required by HERE North America, LLC

The data ("Data") is provided for your personal, internal use only and not for resale. It is protected by copyright, and is subject to the following terms and conditions which are agreed to by you, on the one hand, and Telenav ("Telenav") and its licensors (including their licensors and suppliers) on the other hand.

© 2013 HERE. All rights reserved.

The Data for areas of Canada includes information taken with permission from Canadian authorities, including: © Her Majesty the Queen in Right of Canada, © Queen's Printer for Ontario, © Canada Post Corporation, GeoBase®, © Department of Natural Resources Canada.

HERE holds a non-exclusive license from the United States Postal Service® to publish and sell ZIP+4® information.

©United States Postal Service® 2014. Prices are not established, controlled or approved by the United States Postal Service®. The following trademarks and registrations are owned by the USPS: United States Postal Service, USPS, and ZIP+4.

The Data for Mexico includes certain data from Instituto Nacional de Estadística y Geografía.

TERMS AND CONDITIONS

9.2 End User Terms Required by NAV2 (Shanghai) Co., Ltd

The data ("Data") is provided for your personal, internal use only and not for resale. It is protected by copyright, and is subject to the following terms and conditions which are agreed to by you, on the one hand, and NAV2 (Shanghai) Co., Ltd ("NAV2") and its licensors (including their licensors and suppliers) on the other hand.

© 20xx. All rights reserved.

Permitted Use.

You agree to use this Data together with the Telenav Software solely for the internal business and personal purposes for which you were licensed, and not for service bureau, time-sharing or other similar purposes. Accordingly, but subject to the restrictions set forth in the following paragraphs, you agree not to otherwise reproduce, copy, modify, decompile, disassemble, create any derivative works of, or reverse engineer any portion of this Data, and may not transfer or distribute it in any form, for any purpose, except to the extent permitted by mandatory laws.

Restrictions.

Except where you have been specifically licensed to do so by Telenav, and without limiting the preceding paragraph, you may not use this Data (a) with any products, systems, or applications installed or otherwise connected to or in communication with vehicles, capable of vehicle navigation, positioning, dispatch, real time route guidance, fleet management or similar applications; or (b) with or in communication with any

Appendices

positioning devices or any mobile or wireless-connected electronic or computer devices, including without limitation cellular phones, palmtop and handheld computers, pagers, and personal digital assistants or PDAs.

Warning.

The Data may contain inaccurate or incomplete information due to the passage of time, changing circumstances, sources used and the nature of collecting comprehensive geographic data, any of which may lead to incorrect results.

No Warranty.

This Data is provided to you "as is," and you agree to use it at your own risk. Telenav and its licensors (and their licensors and suppliers) make no guarantees, representations or warranties of any kind, express or implied, arising by law or otherwise, including but not limited to, content, quality, accuracy, completeness, effectiveness, reliability, fitness for a particular purpose, usefulness, use or results to be obtained from this Data, or that the Data or server will be uninterrupted or error-free.

Disclaimer of Warranty:

TELENAV AND ITS LICENSORS (INCLUDING THEIR LICENSORS AND SUPPLIERS) DISCLAIM ANY WARRANTIES, EXPRESS OR IMPLIED, OF QUALITY, PERFORMANCE, MERCHANTABILITY, FITNESS FOR A PARTICULAR PURPOSE OR NON-INFRINGEMENT. Some States, Territories and Countries do not allow certain warranty exclusions, so to that extent the above exclusion may not apply to you.

Disclaimer of Liability:

TELENAV AND ITS LICENSORS (INCLUDING THEIR LICENSORS AND SUPPLIERS) SHALL NOT BE LIABLE TO YOU: IN RESPECT OF ANY CLAIM, DEMAND OR ACTION, IRRESPECTIVE OF THE NATURE OF THE CAUSE OF THE CLAIM, DEMAND OR ACTION ALLEGING ANY LOSS, INJURY OR DAMAGES, DIRECT OR INDIRECT, WHICH MAY RESULT FROM THE USE OR POSSESSION OF THE INFORMATION; OR FOR ANY LOSS OF PROFIT, REVENUE, CONTRACTS OR SAVINGS, OR ANY OTHER DIRECT, INDIRECT, INCIDENTAL, SPECIAL OR CONSEQUENTIAL DAMAGES ARISING OUT OF YOUR USE OF OR INABILITY TO USE THIS INFORMATION, ANY DEFECT IN THE INFORMATION, OR THE BREACH OF THESE TERMS OR CONDITIONS, WHETHER IN AN ACTION IN CONTRACT OR TORT OR BASED ON A WARRANTY, EVEN IF TELENAV OR ITS LICENSORS HAVE BEEN ADVISED OF THE POSSIBILITY OF SUCH DAMAGES. Some States, Territories and Countries do not allow certain liability exclusions or damages limitations, so to that extent the above may not apply to you.

Export Control.

You shall not export from anywhere any part of the Data or any direct product thereof except in compliance with, and with all licenses and approvals required under, applicable export laws, rules and regulations, including but not limited to the laws, rules and regulations administered by the Office of Foreign Assets Control of the U.S. Department of Commerce and the Bureau of Industry and Security of the U.S. Department of Commerce. To the extent

Appendices

that any such export laws, rules or regulations prohibit HERE from complying with any of its obligations hereunder to deliver or distribute Data, such failure shall be excused and shall not constitute a breach of this Agreement.

Entire Agreement.

These terms and conditions constitute the entire agreement between Telenav (and its licensors, including their licensors and suppliers) and you pertaining to the subject matter hereof, and supersedes in their entirety any and all written or oral agreements previously existing between us with respect to such subject matter.

Governing Law.

The above terms and conditions shall be governed by the laws of the State of Illinois, without giving effect to (i) its conflict of laws provisions, or (ii) the United Nations Convention for Contracts for the International Sale of Goods, which is explicitly excluded. You agree to submit to the jurisdiction of the State of Illinois for any and all disputes, claims and actions arising from or in connection with the Data provided to you hereunder.

Government End Users.

If the Data is being acquired by or on behalf of the United States government or any other entity seeking or applying rights similar to those customarily claimed by the United States government, this Data is a "commercial item" as that term is defined at 48 C.F.R. ("FAR") 2.101, is licensed in accordance with these End-User Terms, and each copy of Data delivered or otherwise furnished shall be marked and embedded as appropriate with the following "Notice of Use," and shall be treated in accordance with such Notice:

NOTICE OF USE

CONTRACTOR (MANUFACTURER/
SUPPLIER) NAME: HERE

CONTRACTOR (MANUFACTURER/
SUPPLIER) ADDRESS: c/o Nokia, 425
West Randolph Street, Chicago, Illinois
60606

This Data is a commercial item as defined in FAR 2.101 and is subject to these End-User Terms under which this Data was provided.

© 1987 – 2014 HERE – All rights reserved.

If the Contracting Officer, federal government agency, or any federal official refuses to use the legend provided herein, the Contracting Officer, federal government agency, or any federal official must notify HERE prior to seeking additional or alternative rights in the Data.

I. US/Canada Territory

A. United States Data. The End-User Terms for any Application containing Data for the United States shall contain the following notices:

"HERE holds a non-exclusive license from the United States Postal Service® to publish and sell ZIP+4® information."

"©United States Postal Service® 20XX. Prices are not established, controlled or approved by the United States Postal Service®. The following trademarks and registrations are owned by the USPS: United States Postal Service, USPS, and ZIP+4."

Appendices

B. Canada Data. The following provisions apply to the Data for Canada, which may include or reflect data from third party licensors (“Third Party Data”), including Her Majesty the Queen in Right of Canada (“Her Majesty”), Canada Post Corporation (“Canada Post”) and the Department of Natural Resources of Canada (“NRCan”):

1. Disclaimer and Limitation: Client agrees that its use of the Third Party Data is subject to the following provisions:

a. Disclaimer: The Third Party Data is licensed on an “as is” basis. The licensors of such data, including Her Majesty, Canada Post and NRCan, make no guarantees, representations or warranties respecting such data, either express or implied, arising by law or otherwise, including but not limited to, effectiveness, completeness, accuracy or fitness for a particular purpose.

b. Limitation on Liability: The Third Party Data licensors, including Her Majesty, Canada Post and NRCan, shall not be liable: (i) in respect of any claim, demand or action, irrespective of the nature of the cause of the claim, demand or action alleging any loss, injury or damages, direct or indirect, which may result from the use or possession of such Data; or (ii) in any way for loss of revenues or contracts, or any other consequential loss of any kind resulting from any defect in the Data.

2. Copyright Notice: In connection with each copy of all or any portion of the Data for the Territory of Canada, Client shall affix in a conspicuous manner the following copyright notice on at least one of: (i) the label for the storage media of the copy; (ii) the packaging for the copy; or (iii) other materials packaged with the copy, such as user manuals or end user license agreements: “This data includes information taken with permission from Canadian authorities, including © Her Majesty the Queen in Right of Canada, © Queen’s Printer for Ontario, © Canada Post Corporation, GeoBase®, © The Department of Natural Resources Canada. All rights reserved.”

3. End-User Terms: Except as otherwise agreed by the parties, in connection with the provision of any portion of the Data for the Territory of Canada to End-Users as may be authorized under the Agreement, Client shall provide such End-Users, in a reasonably conspicuous manner, with terms (set forth with other end user terms required to be provided under the Agreement, or as otherwise may be provided, by Client) which shall include the following provisions on behalf of the Third Party Data licensors, including Her Majesty, Canada Post and NRCan:

The Data may include or reflect data of licensors, including Her Majesty the Queen in the Right of Canada (“Her Majesty”), Canada Post Corporation (“Canada Post”) and the Department of Natural Resources Canada (“NRCan”). Such data is licensed on an “as is” basis. The licensors, including Her Majesty, Canada Post and NRCan, make no guarantees, representations or warranties respecting such data,

Appendices

either express or implied, arising by law or otherwise, including but not limited to, effectiveness, completeness, accuracy or fitness for a particular purpose. The licensors, including Her Majesty, Canada Post and NRCan, shall not be liable in respect of any claim, demand or action, irrespective of the nature of the cause of the claim, demand or action alleging any loss, injury or damages, direct or indirect, which may result from the use or possession of the data or the Data. The licensors, including Her Majesty, Canada Post and NRCan, shall not be liable in any way for loss of revenues or contracts, or any other consequential loss of any kind resulting from any defect in the data or the Data.

End User shall indemnify and save harmless the licensors, including Her Majesty, Canada Post and NRCan, and their officers, employees and agents from and against any claim, demand or action, irrespective of the nature of the cause of the claim, demand or action, alleging loss, costs, expenses, damages or injuries (including injuries resulting in death) arising out of the use or possession of the data or the Data.

4. Additional Provisions: The terms contained in this Section are in addition to all of the rights and obligations of the parties under the Agreement. To the extent that any of the provisions of this Section are inconsistent with, or conflict with, any other provisions of the Agreement, the provisions of this Section shall prevail.

II. Mexico. The following provision applies to the Data for Mexico, which includes certain data from the Instituto Nacional de Estadística y Geografía ("INEGI"):

A. Any and all copies of the Data and/or packaging containing Data for Mexico shall contain the following notice: "Fuente: INEGI (Instituto Nacional de Estadística y Geografía)"

III. Latin America Territory

A. Third Party Notices. Any and all copies of the Data and/or packaging relating thereto shall include the respective Third Party Notices set forth below and used as described below corresponding to the Territory (or portion thereof) included in such copy:

Territory Notice

Ecuador "INSTITUTO GEOGRAFICO MILITAR DEL ECUADOR AUTORIZACION N° IGM-2011-01- PCO-01 DEL 25 DE ENERO DE 2011"
"source: © IGN 2009 - BD TOPO ®"

Guadeloupe,
French
Guiana
and

Martinique "Fuente: INEGI (Instituto Nacional de Estadística y Geografía)"
Mexico

IV. Middle East Territory

Appendices

A. Third Party Notices. Any and all copies of the Data and/or packaging relating thereto shall include the respective Third Party Notices set forth below and used as described below corresponding to the Territory (or portion thereof) included in such copy:

Country Notice

Jordan “© Royal Jordanian Geographic Centre”. The foregoing notice requirement for Jordan Data is a material term of the Agreement. If Client or any of its permitted sublicensees (if any) fail to meet such requirement, HERE shall have the right to terminate Client’s license with respect to the Jordan Data.

B. Jordan Data. Client and its permitted sublicensees (if any) are restricted from licensing and/or otherwise distributing HERE’s database for the country of Jordan (“Jordan Data”) for use in Enterprise Applications to (i) non-Jordanian entities for use of the Jordan Data solely in Jordan or (ii) Jordan-based customers. In addition, Client, its permitted sublicensees (if any) and End-Users are restricted from using the Jordan Data in Enterprise Applications if such party is (i) a non-Jordanian entity using the Jordan Data solely in Jordan or (ii) a Jordan-based customer. For purposes of the foregoing, “Enterprise Applications” shall mean Geomarketing applications, GIS applications, mobile business asset management applications, call center applications, telematics applications, public organization Internet applications or for providing geocoding services.

V. Europe Territory

A. Use of Certain Traffic Codes in Europe

1. General Restrictions Applicable to Traffic Codes. Client acknowledges and agrees that in certain countries of the Europe Territory, Client will need to obtain rights directly from third party RDS-TMC code providers to receive and use the Traffic Codes in the Data and to deliver to End-Users Transactions in any way derived from or based on such Traffic Codes. For such countries, HERE shall deliver the Data incorporating Traffic Codes to Client only after receiving certification from Client of its having obtained such rights.

2. Display of Third Party Rights Legends for Belgium. Client shall, for each Transaction that uses Traffic Codes for Belgium, provide the following notice to the End-User: “Traffic Codes for Belgium are provided by the Ministerie van de Vlaamse Gemeenschap and the Ministère de l’Équipement et des Transports.”

B. Paper Maps. With respect to any license granted to Client relating to making, selling or distributing paper maps (i.e., a map fixed on a paper or paper-like medium): (a) such license with respect to Data for the Territory of Great Britain is conditioned on Client’s entering into and complying with a separate written agreement with the Ordnance Survey (“OS”) to create and sell paper maps, Client’s paying to the OS any and all applicable paper map royalties, and Client’s complying with the OS copyright notice requirements; (b) such license for selling or otherwise distributing for charge with respect to Data for the Territory of Czech Republic

Appendices

is conditioned on Client's obtaining prior written consent from Kartografie a.s.; (c) such license for selling or distributing with respect to Data for the Territory of Switzerland is conditioned on Client's obtaining a permit from Bundesamt für Landestopografie of Switzerland; (d) Client is restricted from using Data for the Territory of France to create paper maps with a scale between 1:5,000 and 1:250,000; and (e) Client is restricted from using any Data to create, sell or distribute paper maps that are the same or substantially similar, in terms of data content and specific use of color, symbols and scale, to paper maps published by the European national mapping agencies, including without limitation, Landervermessungämter of Germany, Topografische Dienst of the Netherlands, Nationaal Geografisch Instituut of Belgium, Bundesamt für Landestopografie of Switzerland, Bundesamt für Eich-und Vermessungswesen of Austria, and the National Land Survey of Sweden.

C. OS Enforcement. Without limiting Section IV(B) above, with respect to Data for the Territory of Great Britain, Client acknowledges and agrees that the Ordnance Survey ("OS") may bring a direct action against Client to enforce compliance with the OS copyright notice (see Section IV(D) below) and paper map requirements (see Section IV(B) above) contained in this Agreement.

D. Third Party Notices. Any and all copies of the Data and/or packaging relating thereto shall include the respective Third Party Notices set forth below and used as described below corresponding to the Territory (or portion thereof) included in such copy:

Country(ies) Notice

Austria	"© Bundesamt für Eich- und Vermessungswesen"
Croatia Cyprus, Estonia, Latvia, Lithuania, Moldova, Poland, Slovenia and/or Ukraine	"© EuroGeographics"
France	"source: © IGN 2009 – BD TOPO ®"
Germany	"Die Grundlegendaten wurden mit Genehmigung der zuständigen Behörden entnommen"
Great Britain	"Contains Ordnance Survey data © Crown copyright and database right 2010 Contains Royal Mail data © Royal Mail copyright and database right 2010"
Greece	"Copyright Geomatics Ltd."
Hungary	"Copyright © 2003; Top-Map Ltd."
Italy	"La Banca Dati Italiana è stata prodotta usando quale riferimento anche cartografia numerica ed al tratto prodotta e fornita dalla Regione Toscana."
Norway	"Copyright © 2000; Norwegian Mapping Authority"
Portugal	"Source: IgeoE – Portugal"
Spain	"Información geográfica propiedad del CNIG"

Appendices

Sweden “Based upon electronic data
© National Land Survey
Sweden.”

Switzer- “Topografische Grundlage: ©
land Bundesamt für Landestopo-
graphie.

E. Respective Country Distribution. Client acknowledges that HERE has not received approvals to distribute map data for the following countries in such respective countries: Albania, Belarus, Kyrgyzstan, Moldova and Uzbekistan. HERE may update such list from time to time. The license rights granted to Client under this TL with respect to the Data for such countries are contingent upon Client’s compliance with all applicable laws and regulations, including, without limitation, any required licenses or approvals to distribute the Application incorporating such Data in such respective countries.

VI. Australia Territory

A. Third Party Notices. Any and all copies of the Data and/or packaging relating thereto shall include the respective Third Party Notices set forth below and used as described below corresponding to the Territory (or portion thereof) included in such copy:

Copyright. Based on data provided under license from PSMA Australia Limited (www.pasma.com.au).

Product incorporates data which is © 20XX Telstra Corporation Limited, GM Holden Limited, Intelomatics Australia Pty Ltd and Continental Pty Ltd.

B. Third Party Notices for Australia. In addition to the foregoing, the End-User Terms for any Application containing RDS-TMC Traffic Codes for Australia shall contain the following notice: “Product incorporates traffic location codes which is © 20XX Telstra Corporation Limited and its licensors.”

VII. China Territory

Personal Use Only

You agree to use this Data together with [insert name of Client Application] for the solely personal, non-commercial purposes for which you were licensed, and not for service bureau, time-sharing or other similar purposes. Accordingly, but subject to the restrictions set forth in the following paragraphs, you may copy this Data only as necessary for your personal use to (i) view it, and (ii) save it, provided that you do not remove any copyright notices that appear and do not modify the Data in any way. You agree not to otherwise reproduce, copy, modify, decompile, disassemble or reverse engineer any portion of this Data, and may not transfer or distribute it in any form, for any purpose, except to the extent permitted by mandatory laws.

Restrictions

Except where you have been specifically licensed to do so by NAV2 , and without limiting the preceding paragraph, you may not (a) use this Data with any products, systems, or applications installed or otherwise connected to or in communication with vehicles, capable of vehicle navigation, positioning, dispatch, real time route guidance, fleet management or similar applications; or (b)

Appendices

with or in communication with any positioning devices or any mobile or wireless-connected electronic or computer devices, including without limitation cellular phones, palmtop and handheld computers, pagers, and personal digital assistants or PDAs. You agree to cease using this Data if you fail to comply with these terms and conditions.

Limited Warranty

NAV2 warrants that (a) the Data will perform substantially in accordance with the accompanying written materials for a period of ninety (90) days from the date of receipt, and (b) any support services provided by NAV2 shall be substantially as described in applicable written materials provided to you by NAV2, and NAV2's support engineers will make commercially reasonable efforts to solve any problem issues.

rigCustomer Remedies

NAV2 and its suppliers' entire liability and your exclusive remedy shall be, at NAV2's sole discretion, either (a) return of the price paid, if any, or (b) repair or replacement of the Data that do not meet NAV2's Limited Warranty and that are returned to NAV2 with a copy of your receipt. This Limited Warranty is void if failure of the Data has resulted from accident, abuse, or misapplication. Any replacement Data will be warranted for the remainder of the original warranty period or thirty (30) days, whichever is longer. Neither these remedies nor any product support services offered by NAV2 are available without proof of purchase from an authorized international source.

No Other Warranty:

EXCEPT FOR THE LIMITED WARRANTY SET FORTH ABOVE AND TO THE EXTENT PERMITTED BY APPLICABLE LAW, NAV2 AND ITS LICENSORS (INCLUDING THEIR LICENSORS AND SUPPLIERS) DISCLAIM ANY WARRANTIES, EXPRESS OR IMPLIED, OF QUALITY, PERFORMANCE, MERCHANTABILITY, FITNESS FOR A PARTICULAR PURPOSE, OWNERSHIP OR NON-INFRINGEMENT. Certain warranty exclusions may not be permitted under applicable law, so to that extent the above exclusion may not apply to you.

Limited Liability:

TO THE EXTENT PERMITTED BY APPLICABLE LAW, NAV2 AND ITS LICENSORS (INCLUDING THEIR LICENSORS AND SUPPLIERS) SHALL NOT BE LIABLE TO YOU: IN RESPECT OF ANY CLAIM, DEMAND OR ACTION, IRRESPECTIVE OF THE NATURE OF THE CAUSE OF THE CLAIM, DEMAND OR ACTION ALLEGING ANY LOSS, INJURY OR DAMAGES, DIRECT OR INDIRECT, WHICH MAY RESULT FROM THE USE OR POSSESSION OF THE INFORMATION; OR FOR ANY LOSS OF PROFIT, REVENUE, CONTRACTS OR SAVINGS, OR ANY OTHER DIRECT, INDIRECT, INCIDENTAL, SPECIAL OR CONSEQUENTIAL DAMAGES ARISING OUT OF YOUR USE OF OR INABILITY TO USE THIS INFORMATION, ANY DEFECT IN THE INFORMATION, OR THE BREACH OF THESE TERMS OR CONDITIONS, WHETHER IN AN ACTION IN CONTRACT OR TORT OR BASED ON A WARRANTY, EVEN IF NAV2 OR ITS LICENSORS HAVE BEEN ADVISED OF THE POSSIBILITY OF SUCH DAMAGES. UNDER NO CIRCUMSTANCES SHALL NAV2'S OR ITS SUPPLIERS' LIABILITY HEREUNDER EXCEED THE PRICE PAID. Certain liability exclusions may not be permitted under applicable law, so to that extent the above exclusion may not apply to you.

Appendices

Export Control

You agree not to export to anywhere any part of the Data provided to you or any direct product thereof except in compliance with, and with all licenses and approvals required under, applicable export laws, rules and regulations.

IP Protection

The Data are owned by NAV2 or its suppliers and are protected by applicable copyright and other intellectual property law and treaties. The Data are provided solely on the basis of a license to use, not sale.

Entire Agreement

These terms and conditions constitute the entire agreement between NAV2 (and its licensors, including their licensors and suppliers) and you pertaining to the subject matter hereof, and supersedes in their entirety any and all written or oral agreements previously existing between us with respect to such subject matter.

Governing Law.

The above terms and conditions shall be governed by the laws of the People's Republic of China, without giving effect to (i) its conflict of laws provisions, or (ii) the United Nations Convention for Contracts for the International Sale of Goods, which is explicitly excluded. Any dispute arising from or in connection with the Data provided to you hereunder shall be submitted to the Shanghai International Economic and Trade Arbitration Commission for arbitration.

Gracenote® Copyright

CD and music-related data from Gracenote, Inc., copyright© 2000-2007 Gracenote. Gracenote Software, copyright © 2000-2007 Gracenote. This product and service may practice one or more of the following U.S. Patents #5,987,525, #6,061,680, #6,154,773, #6,161,132, #6,230,192, #6,230,207, #6,240,459, #6,330,593 and other patents issued or pending. Some services supplied under license from Open Globe, Inc. for U.S. Patent: #6,304,523.

Gracenote and CDDB are registered trademarks of Gracenote. The Gracenote logo and logotype, and the "Powered by Gracenote™" logo are trademarks of Gracenote.

Gracenote® End User License Agreement (EULA)

This device contains software from Gracenote, Inc. of 2000 Powell Street Emeryville, California 94608 ("Gracenote").

The software from Gracenote (the "Gracenote Software") enables this device to do disc and music file identification and obtain music-related information, including name, artist, track, and title information ("Gracenote Data") from online servers ("Gracenote Servers"), and to perform other functions. You may use Gracenote Data only by means of the intended End User functions of this device.

This device may contain content belonging to Gracenote's providers. If so, all of the restrictions set forth herein with respect to Gracenote Data shall also apply to such content and such content providers shall be entitled to all of the benefits and protections set forth herein that are available to Gracenote.

Appendices

You agree that you will use the content from Gracenote ("Gracenote Content"), Gracenote Data, the Gracenote Software, and Gracenote Servers for your own personal, non-commercial use only. You agree not to assign, copy, transfer or transmit the Gracenote Content, Gracenote Software or any Gracenote Data (except in a Tag associated with a music file) to any third party. YOU AGREE NOT TO USE OR EXPLOIT GRACENOTE CONTENT, GRACENOTE DATA, THE GRACENOTE SOFTWARE, OR GRACENOTE SERVERS, EXCEPT AS EXPRESSLY PERMITTED HEREIN.

You agree that your non-exclusive licenses to use the Gracenote Content, Gracenote Data, the Gracenote Software, and Gracenote Servers will terminate if you violate these restrictions. If your licenses terminate, you agree to cease any and all use of the Gracenote Content, Gracenote Data, the Gracenote Software, and Gracenote Servers. Gracenote, respectively, reserve all rights in Gracenote Data, the Gracenote Software, and the Gracenote Servers and Gracenote Content, including all ownership rights. Under no circumstances will either Gracenote become liable for any payment to you for any information that you provide, including any copyrighted material or music file information. You agree that Gracenote may enforce its respective rights, collectively or separately, under this agreement against you, directly in each company's own name.

Gracenote uses a unique identifier to track queries for statistical purposes. The purpose of a randomly assigned numeric identifier is to allow Gracenote to count queries without knowing anything about who you are. For more information, see the web page at www.gracenote.com for the Gracenote Privacy Policy.

THE GRACENOTE SOFTWARE, EACH ITEM OF GRACENOTE DATA AND THE GRACENOTE CONTENT ARE LICENSED TO YOU "AS IS". NEITHER GRACENOTE MAKES ANY REPRESENTATIONS OR WARRANTIES, EXPRESS OR IMPLIED, REGARDING THE ACCURACY OF ANY GRACENOTE DATA FROM THE GRACENOTE SERVERS OR GRACENOTE CONTENT. GRACENOTE COLLECTIVELY AND SEPARATELY RESERVE THE RIGHT TO DELETE DATA AND/OR CONTENT FROM THE COMPANIES' RESPECTIVE SERVERS OR, IN THE CASE OF GRACENOTE, CHANGE DATA CATEGORIES FOR ANY CAUSE THAT GRACENOTE DEEMS SUFFICIENT. NO WARRANTY IS MADE THAT EITHER GRACENOTE CONTENT OR THE GRACENOTE SOFTWARE OR GRACENOTE SERVERS ARE ERROR-FREE OR THAT THE FUNCTIONING OF THE GRACENOTE SOFTWARE OR GRACENOTE SERVERS WILL BE UNINTERRUPTED. GRACENOTE IS NOT OBLIGATED TO PROVIDE YOU WITH ANY ENHANCED OR ADDITIONAL DATA TYPES THAT GRACENOTE MAY CHOOSE TO PROVIDE IN THE FUTURE AND IS FREE TO DISCONTINUE ITS ONLINE SERVICES AT ANY TIME. GRACENOTE DISCLAIMS ALL WARRANTIES EXPRESS OR IMPLIED, INCLUDING, BUT NOT LIMITED TO, IMPLIED WARRANTIES OF MERCHANTABILITY, FITNESS FOR A PARTICULAR PURPOSE, TITLE, AND NON-INFRINGEMENT. NEITHER GRACENOTE WARRANTS THE RESULTS THAT WILL BE OBTAINED BY YOUR USE OF THE GRACENOTE SOFTWARE OR ANY GRACENOTE SERVER. IN NO CASE WILL GRACENOTE BE LIABLE FOR ANY CONSEQUENTIAL OR INCIDENTAL DAMAGES OR FOR ANY LOST PROFITS OR LOST REVENUES FOR ANY REASON WHATSOEVER.

© Gracenote 2007.

Appendices

Vehicle with SYNC only United States and Mexico

FCC ID: KMHSG1G1

IC: 1422A-SG1G1

Mexico

Model: KMHSG1P1

NOM-121-SCT1-2009

The operation of this equipment is subject to the following two conditions: (1) This equipment or device may not cause harmful interference, and (2) this equipment or device must accept any interference, including interference that may cause undesired operation.

Vehicle with SYNC with Touchscreen/My Touch

FCC ID: KMHSYNGG2

IC: 1422A-SYNGG2

This device complies with Part 15 of the FCC Rules and with RSS-210 of Industry Canada. Operation is subject to the following two conditions: (1) This device may not cause harmful interference, and (2) this device must accept any interference received, including interference that may cause undesired operation.

WARNING



Changes or modifications not expressly approved by the party responsible for compliance could void the user's authority to operate the equipment. The term "IC" before the radio certification number only signifies that Industry Canada technical specifications were met.

The antenna used for this transmitter must not be co-located or operating in conjunction with any other antenna or transmitter.

SUNA TRAFFIC CHANNEL – TERMS AND CONDITIONS

By activating, using and/or accessing the SUNA Traffic Channel, SUNA Predictive or other content or material provided by Intellematics (together, **SUNA Products and/or Services**), you must accept certain terms and conditions. The following is a brief summary of the terms and conditions that apply to you. To view the full terms and conditions relevant to your use of the SUNA Products and/or Services, please consult www.sunatrafic.com.au/termsandconditions/.

1. Acceptance

By using SUNA Products and/or Services, you will be deemed to have accepted and agreed to be bound by the terms and conditions fully detailed at www.sunatrafic.com.au/termsandconditions/.

2. Intellectual Property

SUNA Products and/or Services are for your personal use. You may not record, or retransmit the content, nor use the content in association with any other traffic information or route guidance service or device not approved by Intellematics. You obtain no right of ownership in any Intellectual Property Rights (including copyright) in the data that is used to provide SUNA Products and/or Services.

3. Appropriate Use

SUNA Products and/or Services are intended as an aid to personal motoring and travel planning, and do not provide comprehensive or accurate information on all occasions. On occasions, you may experience additional delay as a result of using SUNA Products and/or Services. You acknowledge that it is not intended, or suitable, for use in applications where time of arrival or driving directions may impact the safety of the public or yourself.

Appendices

4. Use of SUNA Products and Services while driving

You, and other authorised drivers of the vehicle in which SUNA Products and/or Services are available or installed and active, remain at all times responsible for observing all relevant laws and codes of safe driving. In particular, you agree to only actively operate SUNA Products and/or Services when the Vehicle is at a complete stop and it is safe to do so.

5. Service Continuity and Reception of the SUNA Traffic Channel

We will use reasonable endeavours to provide the SUNA Traffic Channel 24 hours a day, 365 days a year. The SUNA Traffic Channel may occasionally be unavailable for technical reasons or for planned maintenance. We will try to perform maintenance at times when congestion is light. We reserve the right to withdraw SUNA Products and/or Services at any time.

Also, we cannot assure the uninterrupted reception of the SUNA Traffic Channel RDS-TMC signal at any particular location.

6. Limitation of Liability

Neither Intelomatics (nor its suppliers or the manufacturer of your device (the “**Suppliers**”)) shall be liable to you or to any third party for any damages either direct, indirect, incidental, consequential or otherwise arising out of the use of or inability to use SUNA Products and/or Services even if Intelomatics or a Supplier has been advised of the possibility of such damages. You also acknowledge that the neither Intelomatics nor any Supplier guarantees nor make any warranties that relate to the availability, accuracy or completeness of SUNA Products and/or

Services, and to the extent which it is lawful to do so, both Intelomatics and each Supplier excludes any warranties which might otherwise be implied by any State or Federal legislation in relation to SUNA Products and/or Services.

7. Please Note

Great care has been taken in preparing this manual. Constant product development may mean that some information is not entirely up-to-date. The information in this document is subject to change without notice.

WARNING



Operating certain parts of this system while driving can distract your attention away from the road, and possibly cause an accident or other serious consequences. Do not change system settings or enter data non-verbally (using your hands) while driving. Stop the vehicle in a safe and legal manner before attempting these operations. This is important since while setting up or changing some functions you might be required to distract your attention away from the road and remove your hands from the wheel.

Index

A

- A/C
 - See: Climate Control.....89
- About This Manual.....5
- ABS
 - See: Brakes.....130
- ABS driving hints
 - See: Hints on Driving With Anti-Lock Brakes.....130
- Accessories
 - See: Replacement Parts Recommendation.....7
- ACC
 - See: Using Adaptive Cruise Control.....147
- Active Park Assist.....140
 - Deactivating the Active Park Assist Feature.....142
 - Parallel Parking.....140
 - Troubleshooting the System.....143
- Adjusting the Steering Wheel.....41
- Air Conditioning
 - See: Climate Control.....89
- Air Filter
 - See: Changing the Engine Air Filter.....216
- Air Vents.....89
- Alarm
 - See: Anti-Theft Alarm.....39
- All-Wheel Drive.....129
- Ambient Lighting.....51
- Anti-Theft Alarm.....39
 - Alarm System.....39
 - Arming the Alarm.....40
 - Disarming the Alarm.....40
 - Full and Reduced Guard.....40
 - Triggering the Alarm.....40
- Appendices.....351
- At a Glance.....9
 - Front Exterior Overview.....9
 - Instrument Panel Overview.....11
 - Rear Exterior Overview.....13
 - Vehicle Interior Overview.....10
- Audible Warnings and Indicators.....65
 - Door Ajar.....65
 - Front and Rear Park Aid.....66
 - Headlamps On.....65
 - Key in Ignition.....65
 - Lane Departure Warning.....66
 - Parking Brake On.....65
 - Seatbelt Reminder.....65
- Audio Control.....41
- Audio System.....239
 - General Information.....239
- Audio Troubleshooting.....247
- Audio Unit Clock and Date
 - Displays.....242
 - Changing the Time.....242
 - Exact Hour Adjustment.....242
- Audio Unit - Vehicles With: AM/FM/CD/SYNC/DAB/Touchscreen
 - Display.....240
- Autolamps.....47
- Automatic Climate Control.....92
 - Type 1.....92
 - Type 2.....94
- Automatic High Beam Control.....47
 - Activating the System.....48
 - Manually Overriding the System.....49
- Automatic Transmission.....124
 - Emergency Park Position Release Lever.....126
 - Hints on driving with an automatic transmission.....126
 - Selector lever positions.....124
 - Sport Mode and Manual Shifting.....125
- Autowipers.....43
- Auxiliary Power Points.....109
 - 12 Volt DC Power Point.....109
 - AC Power Point.....109
 - Locations.....109
- AWD
 - See: All-Wheel Drive.....129

B

- Battery
 - See: Changing the 12V Battery.....208
- Blind Spot Information System.....159
 - Blind Spot Information System (BLIS™) with Cross Traffic Alert.....159

Index

Bonnet Lock	
See: Opening and Closing the Hood.....	201
Brake and Clutch Fluid Check.....	207
Brakes.....	130
General Information.....	130
Breaking-In.....	177
Brakes and Clutch.....	177
Engine.....	177
Tires.....	177
Bulb Specification Chart.....	214
C	
Cabin Air Filter.....	99
Capacities and Specifications.....	234
Car Wash	
See: Cleaning the Exterior.....	217
Catalytic Converter.....	118
Driving with a Catalytic Converter.....	118
Center Console.....	111
Changing a Bulb.....	210
Approach Lamp and Side Repeater.....	212
Front Fog Lamps.....	212
Lamp Assembly Condensation.....	210
Replacing a Reverse Lamp Bulb.....	213
Replacing the Headlamp Bulbs.....	210
Replacing the License Plate Lamp	
Bulb.....	214
Replacing the Rear Fog Lamp Bulb.....	213
Replacing the Tail, Brake and Turn Signal	
Lamp Bulbs.....	212
Side Repeater.....	211
Changing a Fuse.....	188
Changing a Road Wheel.....	228
Installing a Road Wheel.....	232
Jacking and Lifting Points.....	230
Lug Nuts.....	228
Removing a Road Wheel.....	231
Spare Wheel.....	229
Stowing the Flat Tire.....	232
Vehicle Jack.....	228
Changing the 12V Battery.....	208
Changing the Engine Air Filter.....	216
Changing the Wiper Blades.....	208
Changing the Rear Window Wiper	
Blade.....	209
Changing the Windshield Wiper	
Blades.....	208
Checking MyKey System Status.....	32
Checking the Wiper Blades.....	208
Child Restraint Positioning.....	18
CHECKING SEATBELT FIT.....	19
Typical Booster Seat.....	19
Child Restraints.....	15
.....	15
Child Safety.....	15
Child Safety Locks.....	19
Manual Child Safety Locks.....	19
Cleaning the Exterior.....	217
Body Paintwork Preservation.....	217
Cleaning the Chrome Trim.....	217
Cleaning the Headlamps.....	217
Cleaning the Rear Window.....	217
Cleaning the Running Boards Brightwork	
Trim.....	217
Cleaning the Interior.....	217
Instrument Cluster Screens, LCD Screens	
and Radio Screens.....	218
Rear Windows.....	218
Seatbelts.....	217
Clearing All MyKeys.....	30
Climate.....	331
Climate Control Voice Commands.....	333
Climate Control.....	89
Principle of Operation.....	89
Clock.....	74
Cold Weather Precautions.....	182
Compact Disc Player.....	242
CD Text Display Options.....	246
Compact Disc Playback.....	242
Compact Disc Track Scanning.....	243
Ending Compact Disc Playback.....	246
Fast Forward and Reverse.....	243
MP3 Display Options.....	246
MP3 File Playback.....	244
Repeat Compact Disc Tracks.....	243
Shuffle and Random.....	243
Track Selection.....	243
Coolant Check	
See: Engine Coolant Check.....	205
Creating a MyKey.....	30
Programming/Changing Configurable	
Settings.....	30
Cruise Control.....	42
Principle of Operation.....	146

Index

Cruise control	
See: Using Cruise Control.....	146
Cup Holders.....	111
D	
Daytime Running Lamps.....	49
Diesel Particulate Filter.....	114
Regeneration.....	114
Direction Indicators.....	51
DPF	
See: Diesel Particulate Filter.....	114
Draining the Fuel Filter Water Trap.....	207
Driver Alert.....	153
Principle of Operation.....	153
Using Driver Alert.....	154
Driving Aids.....	153
Driving Hints.....	177
Driving Through Water.....	182
DRL	
See: Daytime Running Lamps.....	49
E	
Electromagnetic Compatibility.....	351
Electronic Locking Differential.....	127
Activating the Electronic Locking Differential.....	127
End User License Agreement.....	355
SYNC / SYNC2 End User License Agreement (EULA).....	361
SYNC™ End User License Agreement (EULA).....	355
Engine Coolant Check.....	205
Adding Engine Coolant.....	206
Engine Immobilizer	
See: Passive Anti-Theft System.....	39
Engine Number.....	237
2.0L Engine Number.....	237
2.0L Engine sticker.....	237
2.2L Engine Number.....	238
2.2L Engine sticker.....	238
Engine Oil Check.....	205
Adding Oil.....	205
Engine Oil Dipstick.....	205
Entertainment.....	309
AM/FM/DAB Radio.....	309
Bluetooth Audio.....	316
CD.....	312
Line In.....	316
SD Card Slot and USB Port.....	313
Supported Media Players, Formats and Metadata Information.....	316
Essential Towing Checks.....	173
Before Towing a Trailer.....	174
Hitches.....	173
Launching or Retrieving a Boat or Personal Watercraft (PWC).....	175
Safety Chains.....	174
Trailer Brakes.....	174
Trailer Lamps.....	174
When Towing a Trailer.....	174
Exterior Mirrors.....	56
Fold-Away Exterior Mirrors.....	57
Heated Exterior Mirrors.....	56
Power Exterior Mirrors.....	56
Power-Folding Mirrors.....	57
F	
Fastening the Seatbelts.....	21
Using Seatbelts During Pregnancy.....	22
Floor Mats.....	182
Fog Lamps - Front	
See: Front Fog Lamps.....	49
Fog Lamps - Rear	
See: Rear Fog Lamps.....	49
Front Fog Lamps.....	49
Front Parking Aid.....	139
Obstacle Distance Indicator.....	139
Fuel and Refueling.....	116
Fuel Quality.....	116
Biodiesel Usage.....	117
Diesel-Winter Driving.....	117
Long-Term Storage.....	117
Fuse Box Locations.....	187
Engine Compartment Fuse Box (Power Distribution Box - PDB).....	187
Fuse Box Locations.....	187
Passenger Compartment Fuse Box.....	188
Pre-Fuse Box.....	187
Fuses.....	187

Index

Fuse Specification Chart - 3.2L	
Duratorq-TDCi (148kW/200PS) -	
Puma.....	189
Battery Mounted Fuse Link.....	196
Engine Compartment Fuse Box.....	189
High Current Fuse Box.....	197
Passenger Compartment Fuse Box.....	197

G

Gauges.....	59
Engine Coolant Temperature Gauge.....	60
Fuel Gauge.....	61
Information Display.....	60
Type 1.....	59
Type 2.....	60
General Information on Radio	
Frequencies.....	26
Global Opening and Closing.....	55
Closing the Windows.....	56
Opening the Windows.....	55
Glove Box.....	111

H

Handbrake	
See: Parking Brake.....	130
Hazard Warning Flashers.....	184
Headlamp Leveling.....	50
Headlamp Removal	
See: Removing a Headlamp.....	210
Headlamp Washers.....	45
Head Restraints.....	100
Heated Seats.....	108
Front Seats.....	108
Heated Windows and Mirrors.....	98
Heated Exterior Mirror.....	98
Heated Rear Window.....	98
Heated Windshield.....	98
Heating	
See: Climate Control.....	89
Hill Descent Control.....	136
Principle of Operation.....	136
Hill Start Assist.....	130
Enable and Disable the System.....	131
Switching the System On and Off.....	132
Using Hill Start Assist.....	131

Hints on Controlling the Interior	
Climate.....	95
Cooling the Interior Quickly.....	97
General Hints.....	95
Heating the Interior Quickly.....	96
Recommended Settings for Cooling.....	97
Recommended Settings for Heating.....	96
Side Window Defogging in Cold	
Weather.....	97
Hints on Driving With Anti-Lock	
Brakes.....	130
Hood Lock	
See: Opening and Closing the Hood.....	201
I	
Ignition Switch.....	113
Information Display Control.....	42
Information Displays.....	67
General Information.....	67
Information.....	326
Calendar.....	327
Emergency Assistance.....	327
Notifications.....	327

Index

Information Messages.....	76
Active Park.....	76
Adaptive Cruise Control.....	77
AdBlue Level.....	78
AdBlue System Malfunction.....	78
Airbag.....	78
Alarm.....	79
AWD.....	79
Battery and Charging System.....	80
Blind Spot Information and Cross Traffic Alert System.....	80
Doors and Locks.....	81
Driver Alert.....	81
Fuel.....	81
Hill Descent Control.....	82
Hill Start Assist.....	81
Keys and Keyless Entry.....	82
Lane Keeping System.....	83
Maintenance.....	83
Park Aid.....	84
Park Brake.....	85
Power Steering.....	85
Powertrain.....	87
Starting System.....	85
Terrain Management System.....	86
Tire Pressure Monitoring System.....	86
Traction Control.....	87
Trailer.....	88
Transmission.....	87
Installing Child Restraints.....	16
CHILD RESTRAINT ANCHORAGE LOCATIONS.....	17
Instrument Cluster.....	59
Interior Lamps.....	51
Cargo Compartment Lamp.....	52
Front Interior Lamp.....	51
Glove Box Lamp.....	52
Rear Interior Lamp.....	52
Interior Mirror.....	57
Auto-Dimming Mirror.....	57
Introduction.....	5
J	
Jump Starting the Vehicle.....	184
Connecting the Jumper Cables.....	184
To Start the Engine.....	185
K	
Keys and Remote Controls.....	26
L	
Lane Keeping System.....	155
Switching the System On and Off.....	156
Lighting Control.....	46
High and Low Beam.....	47
Single Side Parking Lamps.....	46
Lighting.....	46
General Information.....	46
Load Carriers	
See: Roof Racks and Load Carriers.....	168
Load Carrying.....	168
General Information.....	168
Locking and Unlocking.....	34
Locking and Unlocking the Doors from Inside.....	34
Locking and Unlocking the Doors Individually with the Key - Vehicles with Central Locking.....	35
Locking and Unlocking the Doors with the Key.....	34
Opening the Liftgate.....	35
Power Door Locks.....	34
Remote Control.....	34
Locks.....	34
Lug Nuts	
See: Changing a Road Wheel.....	228
M	
Maintenance.....	201
General Information.....	201
Manual Climate Control.....	90
Manual Liftgate.....	35
Closing the Liftgate.....	36
Opening the Liftgate.....	36
Manual Seats.....	101
Adjusting the Height of the Driver Seat.....	102
Adjusting the Lumbar Support of the Driver Seat.....	103
Moving the Seat Backward and Forward.....	102
Recline Adjustment.....	102

Index

Media Hub.....	246
Message Center	
See: Information Displays.....	67
Mirrors	
See: Heated Windows and Mirrors.....	98
See: Windows and Mirrors.....	53
Mobile Communications Equipment.....	8
Moonroof.....	57
Bounce-Back.....	58
MyKey Troubleshooting.....	33
MyKey™.....	29
Principle of Operation.....	29

N

Navigation.....	334
Destination Mode.....	334
Map Mode.....	339
Michelin Travel Guide.....	335
Navigation Map Updates.....	342
Navigation Voice Commands.....	342
Places of Interest (POI) Categories.....	335
Quick-touch Buttons.....	341
Setting Your Navigation Preferences.....	336

O

Off-Road Driving.....	177
After Off-Road Driving.....	181
Basic Off-road Driving Techniques.....	179
Crossing Obstacles.....	181
Driving in Deep Snow.....	181
Driving in Mud.....	180
Driving in Sand.....	180
Hill Climbing.....	181
Off-Road Driving Aids.....	179
Off-road Screen.....	179
Terrain Management System (TMS).....	178
Water Wading.....	181
Oil Check	
See: Engine Oil Check.....	205
Opening and Closing the Hood.....	201
Closing the Hood.....	202
Opening the Hood.....	201
Overhead Console.....	112

P

Parking Aids.....	138
Principle of Operation.....	138
Parking Brake.....	130
Passive Anti-Theft System.....	39
Arming the Engine Immobilizer.....	39
Coded Keys.....	39
Disarming the Engine Immobilizer.....	39
Principle of Operation.....	39
PATS	
See: Passive Anti-Theft System.....	39
Personalized Settings.....	75
Chime deactivation.....	75
Languages.....	75
Measure units.....	75
MyKey.....	75
Temperature units.....	75
Phone.....	318
Making Calls.....	321
Pairing Subsequent Cell Phones.....	320
Pairing Your Cell Phone for the First Time.....	319
Phone Menu Options.....	321
Phone Settings.....	324
Phone Voice Commands.....	325
Receiving Calls.....	321
Text Messaging.....	322
Post-Crash Alert System.....	185
Power Door Locks	
See: Locking and Unlocking.....	34
Power Liftgate.....	36
Closing the Liftgate.....	37
Programming Liftgate Height.....	38
Power Seats.....	103

Index

Power Windows.....	53	Remote Control.....	26
Anti-trap windows.....	54	Changing the Remote Control Battery.....	26
Bounce-Back.....	55	Programming the additional key.....	26
Driver's Door Switches.....	53	Remote Control With a Folding Key	
Front and Rear Passengers' Door		Blade.....	27
Switches.....	53	Reprogramming the Unlocking	
Opening and Closing Other Windows		Function.....	26
Automatically.....	54	Removing a Headlamp.....	210
Opening and Closing the Driver Side		Replacement Parts	
Window Automatically.....	53	Recommendation.....	7
Resetting the Memory of the Electric		Collision Repairs.....	7
Windows - Vehicle with One Touch		Scheduled Maintenance and Mechanical	
Up/Down on Driver Side only.....	54	Repairs.....	7
Safety Mode.....	54	Warranty on Replacement Parts.....	8
Safety Switch for the Rear Windows.....	54	Replacing a Lost Key or Remote	
Pre-Collision Assist.....	164	Control.....	28
Using the Pre-Collision Assist		Roadside Emergencies.....	184
System.....	165	Roof Racks and Load Carriers.....	168
		Load Carrying - Roof Loads.....	168
R		Running-In	
Rear Fog Lamps.....	49	See: Breaking-In.....	177
Rear Parking Aid.....	138	Running Out of Fuel.....	117
Obstacle Distance Indicator.....	139	Filling a Portable Fuel Container.....	118
Rear Passenger Climate Controls.....	98	Fuel Run Dry Protection Feature.....	117
Type 1.....	98	S	
Type 2.....	98	Safety Precautions.....	116
Rear Seats.....	104	Seatbelt Height Adjustment.....	22
Adjusting the Rear Seats.....	104	Seatbelt Maintenance.....	23
Rear View Camera.....	144	Seatbelt Reminder.....	22
Turning the Rear View Camera Off.....	145	Deactivating the seatbelt reminder.....	23
Turning the Rear View Camera On.....	144	Seatbelts.....	20
Using the Display.....	144	Principle of Operation.....	20
Rear View Camera		Seats.....	100
See: Rear View Camera.....	144	Security.....	39
Rear Window Wiper and Washers.....	45	Selecting a Child Restraint System.....	15
Rear Window Washer.....	45	15
Rear Window Wiper.....	45	Selective Catalytic Reduction	
Recommended Towing Weights.....	171	System.....	118
Reduced Engine Performance.....	177	Diesel Exhaust Fluid	
Refueling.....	122	(AdBlue)Guidelines.....	122
Vehicles with Fuel Filler Cap.....	123	Diesel Exhaust Fluid (AdBlue)Level.....	118
		Inoperative Selective Catalytic Reduction	
		System, Poor Quality or Contaminated	
		Diesel Exhaust Fluid (AdBlue).....	121

Index

Settings.....	295
Clock.....	295
Display.....	296
Settings.....	300
Sound.....	298
Vehicle.....	298
Sitting in the Correct Position.....	100
Snow Chains	
See: Using Snow Chains.....	224
Speed Control	
See: Cruise Control.....	146
Speed Limiter.....	153
Principle of Operation.....	153
Using the System.....	153
Stability Control.....	134
Principle of Operation.....	134
Starter Switch	
See: Ignition Switch.....	113
Starting a Diesel Engine.....	114
Cold or Hot Engine.....	114
Failure to Start.....	114
Starting and Stopping the Engine.....	113
General Information.....	113
Steering.....	163
Electric Power Steering.....	163
Steering Wheel Lock.....	113
Unlocking the Steering Wheel.....	114
Steering Wheel.....	41
Storage Compartments.....	111
Sunroof	
See: Moonroof.....	57
Supplementary Restraints System.....	24
Principle of Operation.....	24
Switching Off the Engine.....	115
Vehicles With a Turbocharger.....	115
Symbols Glossary.....	5
SYNC™ 2.....	286
General Information.....	286
SYNC™ Applications and	
Services.....	263
In the Event of a Crash.....	265
Switching Emergency Assistance On and	
Off.....	264
SYNC AppLink.....	267
SYNC Emergency Assistance.....	264
SYNC™.....	248
General Information.....	248
SYNC™ Troubleshooting.....	276

T

Tailgate	
See: Manual Liftgate.....	35
See: Power Liftgate.....	36
Technical Specifications	
See: Capacities and Specifications.....	234
Tire Care.....	219
Tire Care.....	219
Tire Pressure Monitoring System.....	224
Changing Tires With a Tire Pressure	
Monitoring System.....	225
How Temperature Affects the Tire	
Pressures.....	225
Tire Pressure Monitoring System Reset	
Procedure.....	227
Understanding the Tire Pressure Monitoring	
System.....	225
Tires	
See: Wheels and Tires.....	219
Tow Ball.....	170
Driving with a trailer.....	170
Driving without a trailer.....	171
Maintenance.....	171
Tow Ball Hitch Assembly.....	170
Towing a Trailer.....	169
Trailer Tow Module.....	169
Towing Points.....	175
Towing the Vehicle on Four	
Wheels.....	176
All Vehicles.....	176
Vehicles With Automatic	
Transmission.....	176
Towing.....	169
Traction Control.....	133
Principle of Operation.....	133
Trailer Sway Control.....	171
Transmission.....	124
Transmission	
See: Transmission.....	124
Transporting the Vehicle.....	186

Index

Trip Computer.....	74	Using SYNC™ With Your Media Player.....	270
Average Fuel Consumption.....	74	Accessing Your USB Song Library.....	274
Average Speed.....	75	Bluetooth Devices and System Settings.....	276
Digital Speedometer.....	75	Connecting Your Media Player to the USB Port.....	270
Distance to Empty.....	74	Media Menu Features.....	274
Instantaneous fuel consumption.....	74	Media Voice Commands.....	271
Odometer.....	75	What's Playing?.....	271
Outside Air Temperature.....	75	Using SYNC™ With Your Phone.....	252
Resetting the trip computer.....	75	Accessing Features Through the Cell Phone Menu.....	256
Trip Odometer.....	74	Accessing Your Cell Phone Settings.....	259
Type Approvals.....	352	Bluetooth Devices.....	261
Bluetooth.....	355	Cell Phone Options During an Active Call.....	255
iPod.....	355	Cell Phone Voice Commands.....	253
RF Certification Logos.....	352	Making a Call.....	255
SD Card.....	355	Pairing a Cell Phone For the First Time.....	252
U		Pairing Subsequent Cell Phones.....	253
Under Hood Overview - 3.2L Duratorq-TDCi (143kW/194PS) - Puma.....	203	Receiving a Call.....	255
Using Adaptive Cruise Control.....	147	Text Messaging.....	258
Automatic Cancellation.....	150	Using Traction Control.....	133
Blocked Sensor.....	151	Using Voice Recognition.....	249
Canceling the Set Speed.....	149	Helpful Hints.....	249
Changing the Set Speed.....	148	Initiating a Voice Session.....	250
Detection Issues.....	151	System Interaction and Feedback.....	250
Following a Vehicle.....	149	V	
Hilly Condition Usage.....	150	Vehicle Care.....	217
Overriding the System.....	150	Vehicle Dimensions.....	234
Resuming the Set Speed.....	149	Vehicle Identification Number.....	237
Setting the Adaptive Cruise Speed.....	148	Vehicle Identification Plate.....	236
Setting the Gap.....	149	"Built Date".....	236
Switching the System Off.....	149	Ventilation	
Switching the System On.....	148	See: Climate Control.....	89
Switching to Normal Cruise Control.....	152	Vents	
System Not Available.....	151	See: Air Vents.....	89
Using All-Wheel Drive.....	129	VIN	
Using Cruise Control.....	146	See: Vehicle Identification Number.....	237
Switching Cruise Control Off.....	147	Voice Control.....	42
Switching Cruise Control On.....	146		
Using Hill Descent Control.....	136		
HDC Operation.....	137		
Selecting HDC.....	136		
Using Snow Chains.....	224		
Vehicles with Stability Control.....	224		
Using Stability Control.....	135		

Index

W

Warning Lamps and Indicators.....	61
Adaptive Cruise Control Lamp.....	61
AdBlue Lamp.....	64
Anti-Lock Braking System Warning Lamp.....	62
Automatic High Beam Lamp.....	62
Battery Warning Lamp.....	62
Blind Spot Monitor Indicator.....	62
Brake System Warning Lamp.....	62
Cruise Control Indicator.....	62
Direction Indicator.....	62
Door Ajar Indicator.....	62
Electronic Locking Differential.....	63
Engine Coolant Temperature Warning Lamp.....	62
Engine Oil Warning Lamp.....	63
Fasten Rear Seat Belt Warning Lamp.....	64
Fasten Seat Belt Warning Lamp.....	63
Four-Wheel Drive Indicators.....	63
Front Airbag Warning Lamp.....	63
Front Fog Lamps Indicator.....	63
Frost Warning Lamp.....	63
Glow Plug Indicator.....	63
High Beam Indicator.....	63
Hill Descent Control.....	63
Hood Ajar Warning Lamp.....	63
Lane Keeping Aid Indicator.....	63
Liftgate Ajar Warning Lamp.....	64
Low Fuel Level Warning Lamp.....	64
Low Tire Pressure Warning.....	64
Low Washer Fluid.....	64
Over Speed Warning.....	64
Parking Lamps Indicator.....	64
Powertrain Fault.....	64
Rear Fog Lamps Indicator.....	64
Service Engine Soon.....	64
Shift Indicator.....	65
Speed Limiter.....	65
Stability Control Off Indicator.....	65
Stability Control Warning Lamp.....	65
Water-In-Fuel Warning Lamp.....	65
Washer Fluid Check.....	207
Washers	
See: Cleaning the Exterior.....	217
See: Wipers and Washers.....	43
Wheel Nuts	
See: Changing a Road Wheel.....	228
Wheels and Tires.....	219
General Information.....	219
Technical Specifications.....	233
Windows and Mirrors.....	53
Windshield Washers.....	44
Windshield Wipers.....	43
Intermittent Wipe.....	43
Speed Dependent Wipers.....	43
Wiper Blades	
See: Checking the Wiper Blades.....	208
Wipers and Washers.....	43

