

FORD **TRANSIT CONNECT** Owner's Manual



The information contained in this publication was correct at the time of going to print. In the interest of continuous development, we reserve the right to change specifications, design or equipment at any time without notice or obligation. No part of this publication may be reproduced, transmitted, stored in a retrieval system or translated into any language in any form by any means without our written permission. Errors and omissions excepted.

© Ford Motor Company 2013

All rights reserved.

Part Number: CG3587en 07/2013 20130717200456

Table of Contents

Introduction

About This Manual.....	7
Symbols Glossary.....	7
Replacement Parts Recommendation.....	9
Mobile Communications Equipment.....	10
Data Recording.....	10

At a Glance

Front Exterior Overview.....	12
Rear Exterior Overview.....	13
Vehicle Interior Overview.....	14
Instrument Panel Overview - Vehicles With: LHD.....	15
Instrument Panel Overview - Vehicles With: RHD.....	16

Child Safety

Installing Child Seats.....	18
Child Seat Positioning.....	22
Child Safety Locks.....	25

Safety Belts

Fastening the Safety Belts.....	26
Safety Belt Height Adjustment.....	27
Safety Belt Minder.....	28

Supplementary Restraints System

Principle of Operation.....	29
Driver Airbag.....	29
Passenger Airbag.....	30
Side Airbags.....	31
Side Curtain Airbags.....	31

Keys and Remote Controls

General Information on Radio Frequencies.....	32
Remote Control.....	32

Replacing a Lost Key or Remote Control.....	33
--	----

Locks

Locking and Unlocking.....	34
Manual Liftgate.....	37

Security

Passive Anti-Theft System.....	38
Anti-Theft Alarm.....	38

Wipers and Washers

Windshield Wipers.....	41
Autowipers.....	41
Windshield Washers.....	42
Rear Window Wiper and Washers.....	43

Steering Wheel

Adjusting the Steering Wheel.....	44
Audio Control.....	44
Voice Control.....	46
Cruise Control.....	46
Information Display Control.....	46

Lighting

General Information.....	47
Lighting Control.....	47
Autolamps.....	48
Instrument Lighting Dimmer.....	49
Headlamp Exit Delay.....	49
Daytime Running Lamps.....	50
Front Fog Lamps.....	50
Rear Fog Lamps.....	50
Headlamp Leveling.....	50
Cornering Lamps.....	51
Direction Indicators.....	52
Interior Lamps.....	52

Table of Contents

Windows and Mirrors

Power Windows - Vehicles With: One-Touch Down Driver Window.....	53
Power Windows - Vehicles With: Rear Power Windows	53
Exterior Mirrors.....	55
Interior Mirror.....	56
Global Opening and Closing.....	56

Instrument Cluster

Gauges.....	58
Warning Lamps and Indicators.....	59
Audible Warnings and Indicators - Vehicles With: Automatic Transmission.....	62
Audible Warnings and Indicators - Vehicles With: Manual Transmission.....	62

Information Displays

General Information.....	63
Clock.....	67
Trip Computer.....	67
Personalized Settings.....	67
Information Messages.....	68

Climate Control

Principle of Operation.....	73
Air Vents.....	73
Manual Climate Control.....	74
Automatic Climate Control.....	76
Hints on Controlling the Interior Climate.....	77
Rear Passenger Climate Controls.....	79
Heated Windows and Mirrors.....	79
Auxiliary Heater.....	80

Seats

Sitting in the Correct Position.....	84
Head Restraints.....	84
Manual Seats.....	85

Rear Seats.....	89
Heated Seats.....	93
Rear Seat Armrest.....	94

Auxiliary Power Points

Auxiliary Power Points.....	95
Cigar Lighter.....	95

Storage Compartments

Cup Holders.....	96
Center Console.....	96
Overhead Console.....	96
Folding Tray.....	96

Starting and Stopping the Engine

General Information.....	97
Ignition Switch.....	97
Steering Wheel Lock.....	97
Starting a Gasoline Engine - Vehicles With: Manual Transmission.....	98
Starting a Gasoline Engine - Vehicles With: Automatic Transmission.....	98
Starting a Diesel Engine.....	99
Diesel Particulate Filter.....	99
Switching Off the Engine.....	100
Engine Block Heater.....	100

Unique Driving Characteristics

Auto-Start-Stop - Base ECOLite.....	102
Auto-Start-Stop.....	103

Fuel and Refueling

Safety Precautions.....	105
Fuel Quality - Gasoline.....	106
Fuel Quality - Diesel.....	106
Running Out of Fuel.....	106
Catalytic Converter.....	107
Refueling.....	108

Table of Contents

Fuel Consumption.....	109	Parking Aid.....	123
Fuel Consumption Figures - 1.0L EcoBoost (74kW/100PS).....	110	Rear View Camera.....	125
Fuel Consumption Figures - 1.6L EcoBoost (110kW/150PS) - Sigma.....	111	Cruise Control	
Fuel Consumption Figures - 1.6L Duratorq-TDCi (55kW/75PS)/1.6L Duratorq-TDCi (70kW/95PS) (TZ).....	111	Principle of Operation.....	128
Fuel Consumption Figures - 1.6L Duratorq-TDCi (70kW/95PS) (TZ), Base ECOLite.....	112	Using Cruise Control.....	128
Fuel Consumption Figures - 1.6L Duratorq-TDCi (85kW/115PS).....	113	Driving Aids	
Transmission		Speed Limiter.....	129
Manual Transmission - Vehicles With: 6-Speed Manual Transmission.....	114	Active City Stop.....	130
Manual Transmission - Vehicles With: 5-Speed Manual Transmission.....	114	Load Carrying	
Automatic Transmission.....	114	General Information.....	132
Brakes		Rear Under Floor Storage.....	132
General Information.....	118	Luggage Anchor Points.....	133
Hints on Driving With Anti-Lock Brakes.....	118	Cargo Nets.....	133
Parking Brake.....	118	Roof Racks and Load Carriers.....	134
Hill Start Assist - Vehicles With: Automatic Transmission.....	119	Towing	
Hill Start Assist - Vehicles With: Manual Transmission.....	119	Towing a Trailer.....	136
Traction Control		Trailer Sway Control.....	137
Principle of Operation.....	121	Towing Points.....	137
Using Traction Control.....	121	Towing the Vehicle on Four Wheels - Vehicles With: Automatic Transmission.....	138
Stability Control		Towing the Vehicle on Four Wheels - Vehicles With: Manual Transmission.....	139
Principle of Operation.....	122	Transporting the Vehicle.....	139
Using Stability Control.....	122	Driving Hints	
Parking Aids		Breaking-In.....	141
Principle of Operation.....	123	Economical Driving.....	141
		Reduced Engine Performance.....	141
		Cold Weather Precautions.....	142
		Driving Through Water.....	142
		Floor Mats.....	142
		Roadside Emergencies	
		Hazard Warning Flashers.....	144

Table of Contents

First Aid Kit.....	144
Warning Triangle.....	144
Fuel Shutoff.....	144
Jump-Starting the Vehicle.....	144

Fuses

Fuse Box Locations.....	146
Changing a Fuse.....	146
Fuse Specification Chart.....	148

Maintenance

General Information.....	158
Opening and Closing the Hood.....	158
Under Hood Overview - 1.0L EcoBoost (74kW/100PS), Vehicles With: LHD.....	160
Under Hood Overview - 1.0L EcoBoost (74kW/100PS), Vehicles With: RHD.....	161
Under Hood Overview - 1.6L EcoBoost (110kW/150PS) - Sigma, Vehicles With: LHD.....	162
Under Hood Overview - 1.6L EcoBoost (110kW/150PS) - Sigma, Vehicles With: RHD.....	163
Under Hood Overview - 1.6L Duratorq-TDCi (DV) Diesel, Vehicles With: LHD.....	164
Under Hood Overview - 1.6L Duratorq-TDCi (DV) Diesel, Vehicles With: RHD.....	165
Engine Oil Dipstick - 1.0L EcoBoost (74kW/100PS).....	166
Engine Oil Dipstick - 1.6L EcoBoost (110kW/150PS) - Sigma.....	166
Engine Oil Dipstick - 1.6L Duratorq-TDCi (DV) Diesel.....	166
Engine Oil Check.....	166
Engine Coolant Check.....	167
Brake and Clutch Fluid Check.....	167
Washer Fluid Check.....	168
Changing the 12V Battery.....	168
Checking the Wiper Blades.....	168

Changing the Wiper Blades.....	168
Changing a Bulb.....	170
Bulb Specification Chart.....	174
Technical Specifications - 1.0L EcoBoost (74kW/100PS).....	176
Technical Specifications - 1.6L Duratorq-TDCi (DV) Diesel.....	178
Technical Specifications - 1.6L EcoBoost (110kW/150PS) - Sigma.....	179

Vehicle Care

Cleaning the Exterior.....	182
Repairing Minor Paint Damage.....	182
Cleaning the Interior.....	183
Cleaning the Alloy Wheels.....	183

Wheels and Tires

General Information.....	184
Temporary Mobility Kit.....	184
Tire Care.....	188
Using Winter Tires.....	188
Using Snow Chains.....	188
Tire Pressure Monitoring System.....	189
Changing a Road Wheel.....	192
Technical Specifications - Vehicles With: Short Wheelbase Kombi.....	197
Technical Specifications - Vehicles With: Long Wheelbase Kombi.....	197
Technical Specifications - Vehicles With: Short Wheelbase Van.....	198
Technical Specifications - Vehicles With: Long Wheelbase Van.....	199
Technical Specifications - Vehicles With: Short Wheelbase Double Cab in Van.....	199
Technical Specifications - Vehicles With: Long Wheelbase Double Cab in Van.....	200

Table of Contents

Capacities and Specifications

Vehicle Dimensions - Vehicles With: Long Wheelbase Kombi.....	201
Vehicle Dimensions - Vehicles With: Long Wheelbase Double Cab in Van/Long Wheelbase Van.....	201
Vehicle Dimensions - Vehicles With: Short Wheelbase Kombi.....	202
Vehicle Dimensions - Vehicles With: Short Wheelbase Double Cab in Van/Short Wheelbase Van.....	202
Towbar Dimensions.....	203
Vehicle Identification Plate.....	204
Vehicle Identification Number.....	205

Audio System

General Information.....	206
Audio unit - Vehicles With: AM/FM/CD/Digital Audio Broadcast (DAB) Radio/SYNC.....	207
Audio unit - Vehicles With: Digital Audio Broadcast (DAB) Radio/Navigation System.....	212
Audio unit - Vehicles With: AM/FM/Digital Audio Broadcast (DAB) Radio.....	218
Digital Audio.....	225
Auxiliary Input Jack.....	227
USB Port.....	227
Media Hub.....	228
Audio Troubleshooting.....	228

Navigation

Navigation.....	229
-----------------	-----

SYNC™

General Information.....	237
Using Voice Recognition.....	238
Using SYNC™ With Your Phone.....	241
SYNC™ Applications and Services.....	251

Using SYNC™ With Your Media Player.....	254
SYNC™ Troubleshooting.....	258

Appendices

Electromagnetic compatibility.....	266
End User License Agreement.....	267

Introduction

ABOUT THIS MANUAL

Thank you for choosing Ford. We recommend that you take some time to get to know your vehicle by reading this manual. The more that you know about it, the greater the safety and pleasure you will get from driving it.

WARNING



Driving while distracted can result in loss of vehicle control, crash and injury. We strongly recommend that you use extreme caution when using any device that may take your focus off the road. Your primary responsibility is the safe operation of your vehicle. We recommend against the use of any handheld device while driving and encourage the use of voice-operated systems when possible. Make sure you are aware of all applicable local laws that may affect the use of electronic devices while driving.

Note: This manual describes product features and options available throughout the range of available models, sometimes even before they are generally available. It may describe options not fitted to your vehicle.

Note: Some of the illustrations in this manual may be used for different models, so may appear different to you on your vehicle. However, the essential information in the illustrations is always correct.

Note: Always use and operate your vehicle in line with all applicable laws and regulations.

Note: Pass on this manual when selling your vehicle. It is an integral part of the vehicle.

This manual may qualify the location of a component as left-hand side or right-hand side. The side is determined when facing forward in the seat.

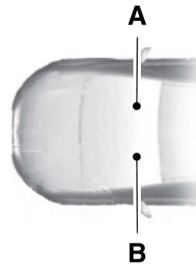

E154903

- A Right-hand side
- B Left-hand side

Protecting the Environment

You must play your part in protecting the environment. Correct vehicle usage and the authorized disposal of waste, cleaning and lubrication materials are significant steps toward this aim.

SYMBOLS GLOSSARY

These are some of the symbols you may see on your vehicle.



Safety alert



See Owner's Manual



Air conditioning system



Anti-lock braking system



Avoid smoking, flames or sparks



Battery

Introduction



Battery acid



Explosive gas



Brake fluid - non petroleum based



Fan warning



Brake system



Fasten safety belt



Cabin air filter



Front airbag



Check fuel cap



Front fog lamps



Child safety door lock or unlock



Fuel pump reset



Child seat lower anchor



Fuse compartment



Child seat tether anchor



Hazard warning flashers



Cruise control



Heated rear window



Do not open when hot



Heated windshield



Engine air filter



Interior luggage compartment release



Engine coolant



Jack



Engine coolant temperature



Keep out of reach of children



Engine oil



Lighting control



Low tire pressure warning

Introduction



Maintain correct fluid level



Note operating instructions



Panic alarm



Parking aid



Parking brake



Power steering fluid



Power windows front/rear



Power window lockout



Service engine soon



Side airbag



Shield the eyes



Stability control



Windshield wash and wipe

REPLACEMENT PARTS RECOMMENDATION

Your vehicle has been built to the highest standards using quality parts. We recommend that you demand the use of genuine Ford and Motorcraft parts whenever your vehicle requires scheduled maintenance or repair. You can clearly identify genuine Ford and Motorcraft parts by looking for the Ford, FoMoCo or Motorcraft branding on the parts or their packaging.

Scheduled Maintenance and Mechanical Repairs

One of the best ways for you to make sure that your vehicle provides years of service is to have it maintained in line with our recommendations using parts that conform to the specifications detailed in this Owner's Manual. Genuine Ford and Motorcraft parts meet or exceed these specifications.

Collision Repairs

We hope that you never experience a collision, but accidents do happen. Genuine Ford replacement collision parts meet our stringent requirements for fit, finish, structural integrity, corrosion protection and dent resistance. During vehicle development we validate these parts deliver the intended level of protection as a whole system. A great way to know for sure you are getting this level of protection is to use genuine Ford replacement collision parts.

Introduction

Warranty on Replacement Parts

Genuine Ford and Motorcraft replacement parts are the only replacement parts that benefit from a Ford Warranty. Damage caused to your vehicle as a result of the failure of non-Ford parts may not be covered by the Ford Warranty. For additional information, refer to the terms and conditions of the Ford Warranty.

MOBILE COMMUNICATIONS EQUIPMENT

Using mobile communications equipment is becoming increasingly important in the conduct of business and personal affairs. However, you must not compromise your own or others' safety when using such equipment. Mobile communications can enhance personal safety and security when appropriately used, particularly in emergency situations. Safety must be paramount when using mobile communications equipment to avoid negating these benefits. Mobile communication equipment includes, but is not limited to, cellular phones, pagers, portable email devices, text messaging devices and portable two-way radios.

WARNING



Driving while distracted can result in loss of vehicle control, crash and injury. We strongly recommend that you use extreme caution when using any device that may take your focus off the road. Your primary responsibility is the safe operation of your vehicle. We recommend against the use of any hand-held device while driving and encourage the use of voice-operated systems when possible. Make sure you are aware of all applicable local laws that may affect the use of electronic devices while driving.

DATA RECORDING

A large number of electronic components of your vehicle contain data storage modules temporarily or permanently storing technical data about the condition of the vehicle, events and errors.

In general, this technical information documents the condition of parts, modules, systems or the environment:

- Operating conditions of system components (e.g. filling levels).
- Status messages of the vehicle and its individual components (e.g. number of wheel revolutions/rotational speed, deceleration, lateral acceleration).
- Malfunction and defects in important system components (e.g. lighting and brake system).
- Vehicle reactions in particular driving situations (e.g. inflation of an airbag, activation of the stability regulation system).
- Environmental conditions (e.g. temperature).

These data are exclusively technical and help identification and correction of errors as well as optimisation of vehicle functions. Motion profiles indicating travelled routes cannot be created with these data.

If services are used (e.g. repair works, service processes, warranty cases, quality assurance), employees of the service network (including manufacturers) are able to read out this technical information from the event and error data storage modules using special diagnostic devices. If required, you will receive further information. After an error has been corrected, these data are deleted from the error storage module or they are constantly overwritten.

Introduction

When using the vehicle, situations may occur in which these technical data related to other information (accident report, damages on the vehicle, witness statements etc.) may be associated with a specific person - possibly, with the assistance of an expert.

Additional functions contractually agreed upon with the client (e.g. vehicle location in emergency cases) allow the transmission of particular vehicle data from the vehicle.

At a Glance

FRONT EXTERIOR OVERVIEW

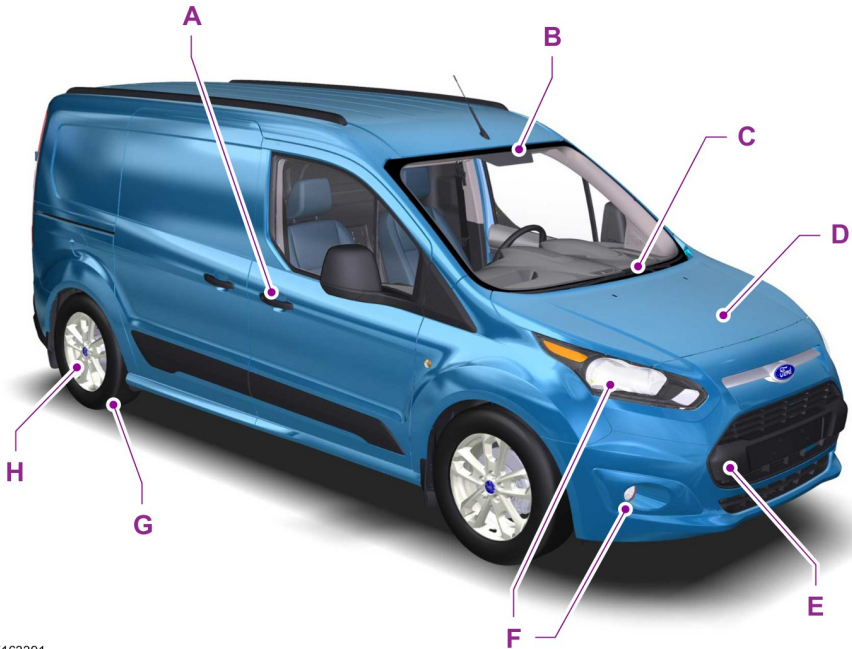

E163391

- A See **Locking and Unlocking** (page 34).
- B See **Speed Limiter** (page 129).
- C See **Changing the Wiper Blades** (page 168).
- D See **Maintenance** (page 158).
- E See **Towing Points** (page 137).
- F See **Changing a Bulb** (page 170).
- G Tire pressures. See **Technical Specifications** (page 197).
- H See **Changing a Road Wheel** (page 192).

At a Glance

REAR EXTERIOR OVERVIEW

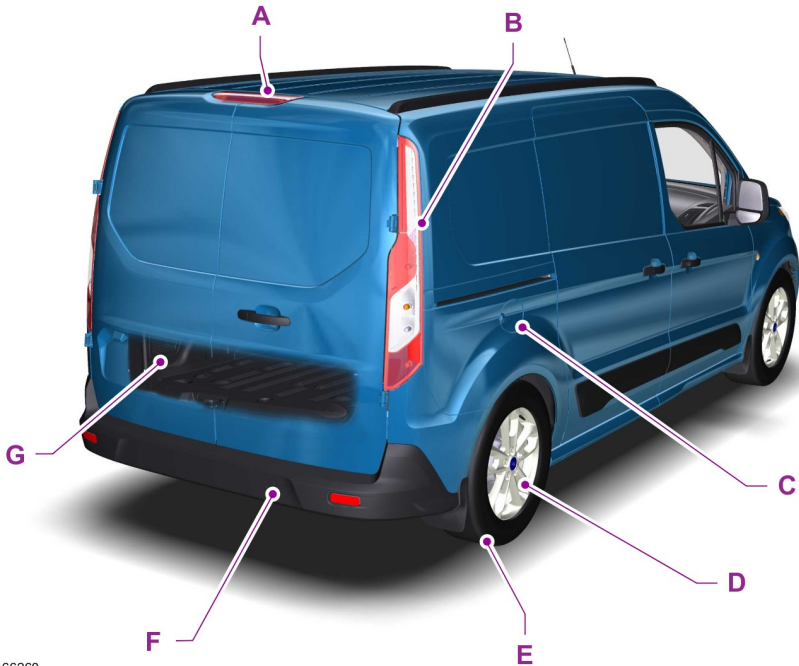

E166260

- A See **Changing a Bulb** (page 170).
- B See **Changing a Bulb** (page 170).
- C See **Refueling** (page 108).
- D See **Changing a Road Wheel** (page 192).
- E Tire pressures. See **Technical Specifications** (page 197).
- F See **Towing Points** (page 137).
- G See **Temporary Mobility Kit** (page 184). Spare wheel, jack and wheel brace. See **Changing a Road Wheel** (page 192). Towing eye. See **Towing Points** (page 137).

At a Glance

VEHICLE INTERIOR OVERVIEW

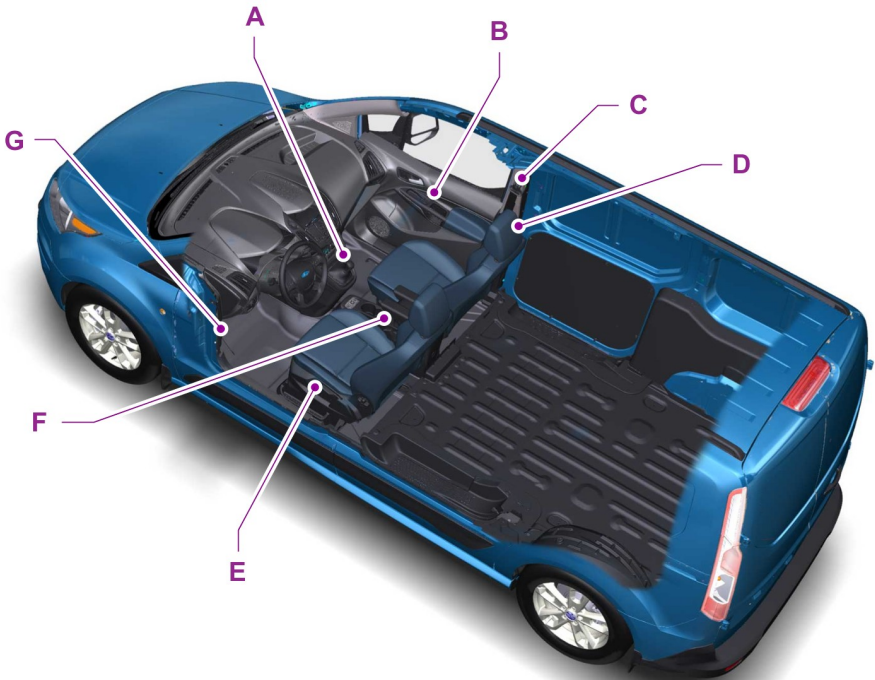

E163393

- A See **Transmission** (page 114).
- B See **Power Windows** (page 53). See **Exterior Mirrors** (page 55).
- C See **Fastening the Safety Belts** (page 26).
- D See **Head Restraints** (page 84).
- E See **Manual Seats** (page 85).
- F See **Parking Brake** (page 118).
- G See **Opening and Closing the Hood** (page 158).

At a Glance

INSTRUMENT PANEL OVERVIEW - VEHICLES WITH: LHD

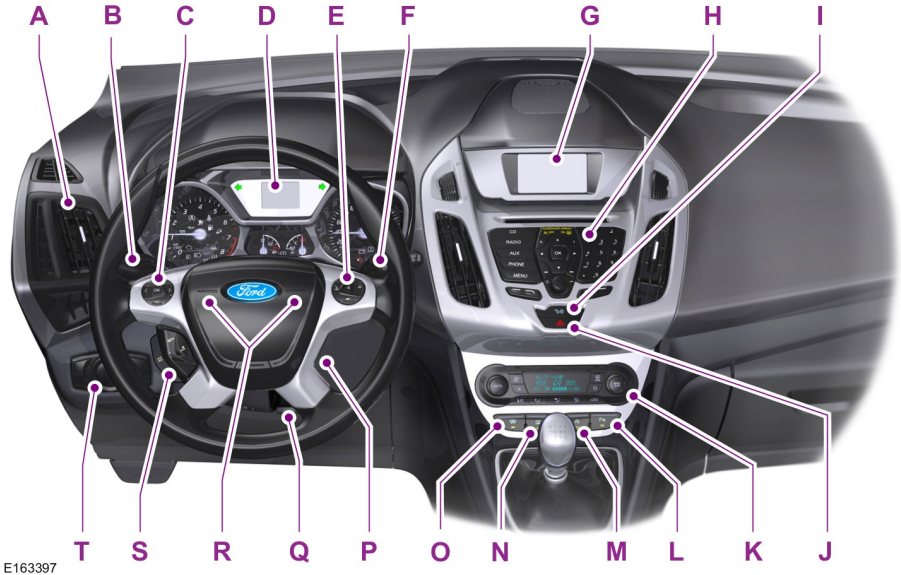

E163397

- A Air vents. See **Air Vents** (page 73).
- B Direction indicators. See **Direction Indicators** (page 52). High beam. See **Lighting Control** (page 47).
- C Information display controls. See **Information Displays** (page 63).
- D Instrument cluster. See **Gauges** (page 58). See **Warning Lamps and Indicators** (page 59).
- E Audio control. See **Audio Control** (page 44). Voice control. See **Voice Control** (page 46).
- F Wiper lever. See **Wipers and Washers** (page 41).
- G Information and entertainment display.
- H Audio unit. See **Audio System** (page 206).
- I Door lock indicator. See **Locking and Unlocking** (page 34).
- J Hazard warning flasher switch. See **Hazard Warning Flashers** (page 144).
- K Climate controls. See **Climate Control** (page 73).

At a Glance

- L Parking aid switch. See **Parking Aids** (page 123).
- M Start-stop switch. See **Auto-Start-Stop** (page 102).
- N Heated rear window switch. See **Heated Windows and Mirrors** (page 79).
- O Heated windshield switch. See **Heated Windows and Mirrors** (page 79).
- P Ignition switch. See **Ignition Switch** (page 97).
- Q Steering wheel adjustment. See **Adjusting the Steering Wheel** (page 44).
- R Horn.
- S Cruise control switches. See **Using Cruise Control** (page 128).
- T Lighting control. See **Lighting Control** (page 47). Front fog lamps. See **Front Fog Lamps** (page 50). Rear fog lamp. See **Rear Fog Lamps** (page 50). Headlamp leveling control. See **Headlamp Leveling** (page 50).

INSTRUMENT PANEL OVERVIEW - VEHICLES WITH: RHD

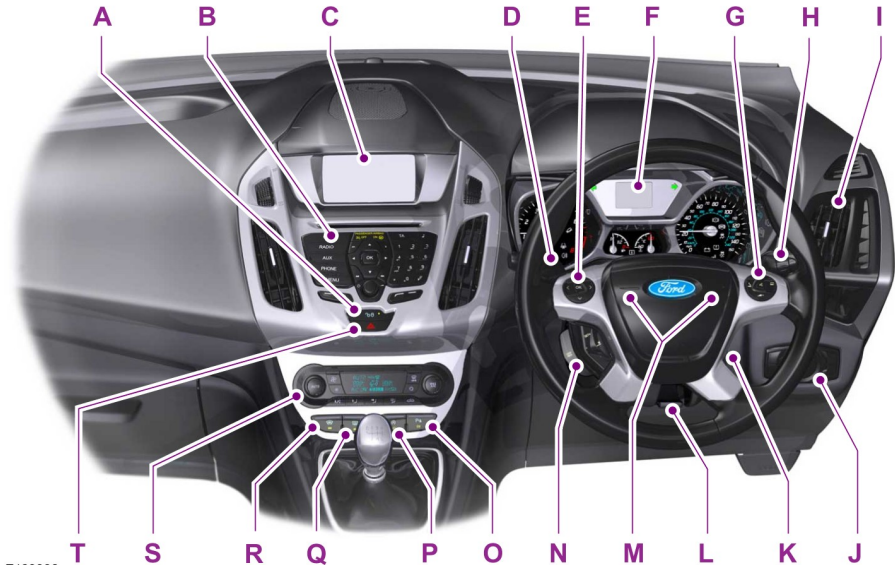

E163398

At a Glance

- A Door lock indicator. See **Locking and Unlocking** (page 34).
- B Audio unit. See **Audio System** (page 206).
- C Information and entertainment display.
- D Direction indicators. See **Direction Indicators** (page 52). High beam. See **Lighting Control** (page 47).
- E Information display controls. See **Information Displays** (page 63).
- F Instrument cluster. See **Gauges** (page 58). See **Warning Lamps and Indicators** (page 59).
- G Audio control. See **Audio Control** (page 44). Voice control. See **Voice Control** (page 46).
- H Wiper lever. See **Wipers and Washers** (page 41).
- I Air vents. See **Air Vents** (page 73).
- J Lighting control. See **Lighting Control** (page 47). Front fog lamps. See **Front Fog Lamps** (page 50). Rear fog lamp. See **Rear Fog Lamps** (page 50). Headlamp leveling control. See **Headlamp Leveling** (page 50).
- K Ignition switch. See **Ignition Switch** (page 97).
- L Steering wheel adjustment. See **Adjusting the Steering Wheel** (page 44).
- M Horn.
- N Cruise control switches. See **Using Cruise Control** (page 128).
- O Parking aid switch. See **Parking Aids** (page 123).
- P Start-stop switch. See **Auto-Start-Stop** (page 102).
- Q Heated rear window switch. See **Heated Windows and Mirrors** (page 79).
- R Heated windshield switch. See **Heated Windows and Mirrors** (page 79).
- S Climate controls. See **Climate Control** (page 73).
- T Hazard warning flasher switch. See **Hazard Warning Flashers** (page 144).

Child Safety

INSTALLING CHILD SEATS



E161855



E133140

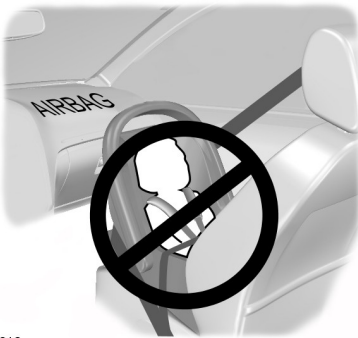



E68916

WARNINGS

 Extreme Hazard! Do not use a rearward facing child seat on a seat protected by an active airbag in front of it!

WARNINGS

 Your vehicle has a passenger airbag deactivation switch. See **Passenger Airbag** (page 30). You must switch the airbag off when using a rearward facing child seat on the front seat. Make sure you switch the airbag back on following removal of the rearward facing child seat. Failure to follow this warning could result in serious personal injury or death.

 Use an approved child seat to secure children less than 59 inches (150 centimeters) tall on the rear seat. Failure to follow this warning could result in serious personal injury or death.

 Read and follow the manufacturer's instructions when you are installing a child seat. Failure to follow this warning could result in serious personal injury or death.

 Do not modify child seats in any way. Failure to follow this warning could result in serious personal injury or death.

 Do not hold a child on your lap when your vehicle is moving. Failure to follow this warning could result in serious personal injury or death.

 Do not leave unattended children in your vehicle. Failure to follow this warning could result in serious personal injury or death.

 If your vehicle has been involved in a crash, have the child seats checked by an authorized dealer. Failure to follow this warning could result in serious personal injury or death.

Only child seats certified to ECE-R44.03 (or later) have been tested and approved for use in your vehicle. A choice of these are available from an authorized dealer.

Note: *Mandatory use of child seats varies from country to country.*

Child Safety

Child Seats for Different Mass Groups

Use the correct child seat as follows:

Rearward Facing Baby Safety Seat



E68918

Secure children that weigh less than 29 pounds (13 kilograms) in a rearward facing baby safety seat (Group 0+) on the rear seat.

Child Safety Seat





E68920

Secure children that weigh between 29 pounds (13 kilograms) and 40 pounds (18 kilograms) in a child safety seat (Group 1) on the rear seat.

Booster Seats

WARNINGS

 Do not install a booster seat or a booster cushion with only the lap strap of the safety belt. Failure to follow this warning could result in serious personal injury or death.

 Do not install a booster seat or a booster cushion with a safety belt that is slack or twisted. Failure to follow this warning could result in serious personal injury or death.

 Do not put the safety belt under your child's arm or behind their back. Failure to follow this warning could result in serious personal injury or death.

 Do not use pillows, books or towels to boost your child's height. Failure to follow this warning could result in serious personal injury or death.

 Make sure that your child sits in an upright position. Failure to follow this warning could result in serious personal injury or death.

 Make sure the child seat rests tightly against the vehicle seat. If necessary, adjust the seatback to an upright position. It may also be necessary to lift or remove the head restraint. See **Head Restraints** (page 84). Failure to follow this warning could result in serious personal injury or death.

 You must reinstall the head restraint following the removal of the child seat. See **Head Restraints** (page 84). Failure to follow this warning could result in serious personal injury or death.

Secure children that weigh more than 33 pounds (15 kilograms) but are less than 59 inches (150 centimeters) tall in a booster seat or a booster cushion.

Child Safety

Booster Seat (Group 2)



E70710

We recommend that you use a booster seat that combines a cushion with a backrest instead of a booster cushion only. The raised seating position will allow you to position the shoulder strap of the adult safety belt over the center of your child's shoulder and the lap strap tightly across their hips.

Booster Cushion (Group 3)



E68924

ISOFIX Anchor Points

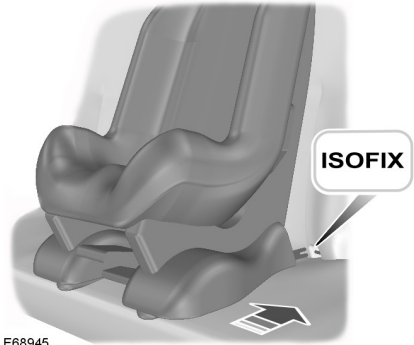

E68945

WARNING

 Use an anti-rotation device when using the ISOFIX system. We recommend the use of a top tether or support leg. Failure to follow this warning could result in serious personal injury or death.

Your vehicle has ISOFIX anchor points that accommodate universally approved ISOFIX child seats.

The ISOFIX system has two rigid attachment arms on the child seat. These attach to anchor points on the second row seats, where the cushion and backrest meet. For child seats with a top tether, tether anchor points are on the underside or rear of the second row seats.

Note: When you are purchasing an ISOFIX seat, make sure that you know the correct mass group and ISOFIX size class for the intended seating locations. See **Child Seat Positioning** (page 22).

Child Safety

Attaching a Child Seat With Top Tethers

WARNING

 Do not attach the top tether strap to anything other than the correct top tether strap anchor point. Failure to follow this warning could result in serious personal injury or death.

Follow the child seat manufacturer's instructions for installing a child seat with a top tether.

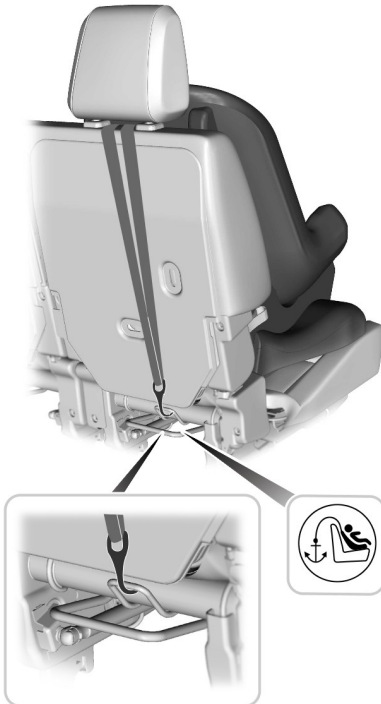

E165605

Attaching a Child Seat With a Support Leg

WARNINGS

 Make sure the support leg is long enough to reach the vehicle floor. Failure to follow this warning could result in serious personal injury or death.

 Make sure that the child seat manufacturer lists your vehicle as suitable for use with this type of child seat. Failure to follow this warning could result in serious personal injury or death.

Follow the child seat manufacturer's instructions for installing a child seat with a support leg.





E165606

Child Safety

CHILD SEAT POSITIONING

WARNINGS

 See an authorized dealer for the latest details relating to our recommended child seats. Failure to follow this warning could result in serious personal injury or death.

 Extreme Hazard! Do not use a rearward facing child seat on a seat protected by an air bag in front of it!

 When using a child seat with a support leg, the support leg must rest securely on the floor. Failure to follow this warning could result in serious personal injury or death.

 When using a child seat with a safety belt, make sure that the safety belt is not slack or twisted. Failure to follow this warning could result in serious personal injury or death.

WARNINGS

 Make sure the child seat rests tightly against the vehicle seat. If necessary, adjust the seatback to an upright position. It may also be necessary to lift or remove the head restraint. See **Head Restraints** (page 84). Failure to follow this warning could result in serious personal injury or death.

 You must reinstall the head restraint following the removal of the child seat. See **Head Restraints** (page 84). Failure to follow this warning could result in serious personal injury or death.

Note: *When using a child seat on a front seat, always adjust the front passenger seat as far back as possible. If it proves difficult to tighten the lap section of the safety belt without slack remaining, adjust the seatback to the fully upright position and raise the height of the seat. See **Seats** (page 84).*

Seating positions	Mass group categories				
	0	0+	1	2	3
	Up to 22 lbs (10 kg)	Up to 29 lbs (13 kg)	20 - 40 lbs (9 - 18 kg)	33 - 55 lbs (15 - 25 kg)	46 - 79 lbs (22 - 36 kg)
Front passenger seat with airbag ON	X	X	UF ¹	UF ¹	UF ¹
Front passenger seat with airbag OFF	U ¹	U ¹	U ¹	U ¹	U ¹
Fold-flat front passenger seat with airbag ON	X	X	L ¹	L ¹	L ¹
Fold-flat front passenger seat with airbag OFF	X	L ¹	L ¹	L ¹	L ¹
Dual front passenger seat - center seat only	X	X	X	X	X

Child Safety

Seating positions	Mass group categories				
	0	0+	1	2	3
	Up to 22 lbs (10 kg)	Up to 29 lbs (13 kg)	20 - 40 lbs (9 - 18 kg)	33 - 55 lbs (15 - 25 kg)	46 - 79 lbs (22 - 36 kg)
Second row rear seats	U	U	U	U	U
Third row rear seats	U	U	U	U	U

X Not suitable for children in this mass group.

U Suitable for universal category child restraints approved for use in this mass group.

U¹ Suitable for universal category child restraints approved for use in this mass group. We recommend that you secure children in a government approved child seat, on a rear seat.

UF¹ Suitable for universal category forward facing child seats approved for use in this mass group. We recommend that you secure children in a government approved child seat, on a rear seat.

L¹ Suitable only for the following child seats:

- Group 0+: Britax Baby-Safe Plus (E1-04301146) also with Britax Baby-Safe Belted Base (E1-04301146). Maxi-Cosi CabrioFix (E4-04443517) also with EasyBase 2 (E4-04443523) or EasyFix (E4-04443522).
- Group 1: Recaro Young Expert (E1-04301150). Britax Duo Plus (belted) (E1-04301133). Britax Safefix (belted) (E1-04301199).
- Group 2 and 3: Britax Kidfix (belted only) (E1-04301198). Britax Kid (E1-04301148).
- We recommend that you secure children in a government approved child seat, on a rear seat.

Child Safety

ISOFIX Child Seats

Seating positions		Mass group categories			
		0	0+	I	
		Rear facing		Forward facing	Rear facing
		Up to 29 lbs (13 kg)		20 - 40 lbs (9 - 18 kg)	
Front passenger seat	Size class	Not ISOFIX equipped			
	Size type				
Second row rear outboard seat ISOFIX	Size class	C, D, E ¹	A, B, B1 ¹	C, D ¹	
	Size type	IL ²	IL ² , IUF ³	IL ²	
Second row rear center seat	Size class	Not ISOFIX equipped			
	Size type				
Third row rear seats	Size class	Not ISOFIX equipped			
	Size type				

IL Suitable for use with particular ISOFIX child restraints systems in the semi-universal category. Refer to the child restraint system manufacturer vehicle recommendation list for additional information.

IUF Suitable for use with forward facing ISOFIX child restraints systems in the universal category.

¹The capital letters A to G define the ISOFIX size class for both universal and semi-universal child restraints systems. You can see the identification letters on ISOFIX child restraints.

²At the time of going to print, the recommended Group O+ ISOFIX baby safety seat is the Britax Roemer Baby Safe. See an authorized dealer for the latest details relating to Ford recommended child seats.

³At the time of going to print, the recommended Group I ISOFIX child seat is the Britax Roemer Duo. See an authorized dealer for the latest details relating to Ford recommended child seats.

Child Safety

CHILD SAFETY LOCKS

WARNING



You cannot open the doors from inside if you have put the child safety locks on.

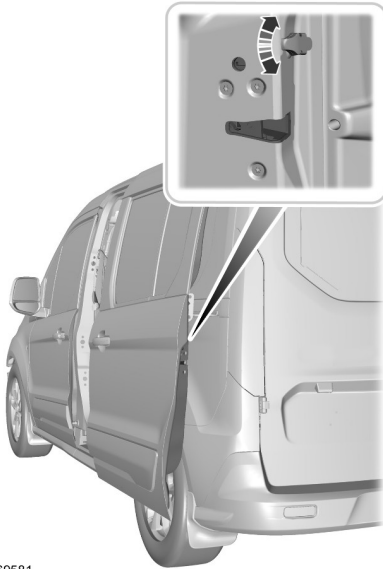

E169581

The childproof locks are located on the rear edge of each rear door and must be set separately for each door.

Left-Hand Side

Turn counterclockwise to lock and clockwise to unlock.

Right-Hand Side

Turn clockwise to lock and counterclockwise to unlock.

Safety Belts

FASTENING THE SAFETY BELTS

WARNINGS



You have not fastened the safety belt correctly if you do not hear a distinct click. Failure to fasten the safety belt correctly could reduce its effectiveness and increase the risk of injury in a crash.



Make sure that your safety belt is securely stored away and is not outside your vehicle when closing the door. Failure of an occupant to be able to use a trapped safety belt increases the risk of serious personal injury or death.



E74124



E168585

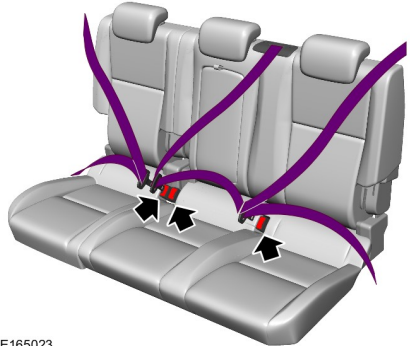

E165023

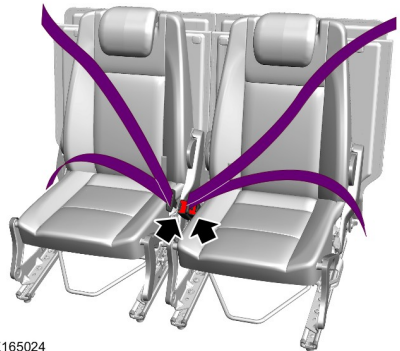

E165024

Safety Belts

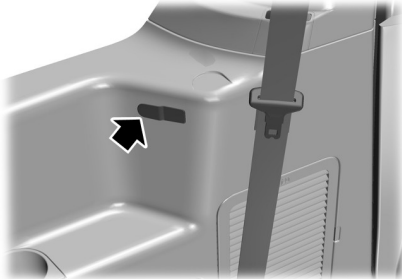

E168648

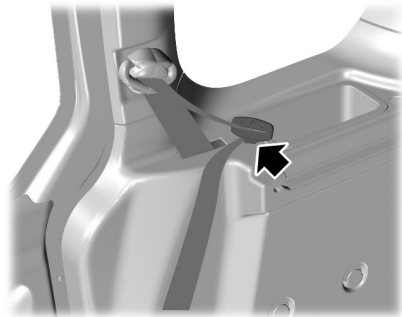

E168649

Note: When not in use, place the safety belts in to the slots on the outboard trim.

Pull the safety belt out steadily. It may lock if you pull it sharply or if your vehicle is on a slope.

Insert the tongue into the buckle until you hear a distinct click.

To release the safety belt press the red button on the buckle. Hold the tongue and let the safety belt retract to its stowed position.

Using Safety Belts During Pregnancy

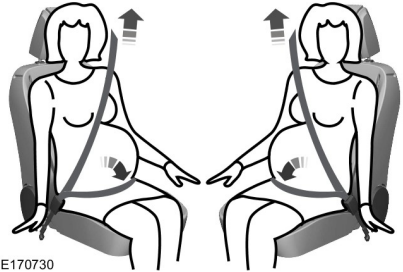

E170730

WARNING

 Position the safety belt correctly for your safety and that of your unborn child. Do not use only the lap strap or the shoulder strap. Failure to adjust the safety belt correctly could reduce its effectiveness and increase the risk of injury in a crash.

Pregnant women should always wear their safety belt. The lap belt portion of a combination lap and shoulder belt should be positioned low across the hips below the belly and worn as tight as comfort will allow. The shoulder belt portion of a combination lap and shoulder belt should be positioned to cross the middle of the shoulder and the center of the chest.

SAFETY BELT HEIGHT ADJUSTMENT

WARNING

 Position the safety belt height adjuster so that the safety belt rests across the middle of your shoulder. Failure to adjust the safety belt correctly could reduce its effectiveness and increase the risk of injury in a crash.

Safety Belts

If you do not fasten your safety belt both the audible and visual warnings will switch off automatically after approximately five minutes.

Turning the Safety Belt Minder Off

See an authorized dealer.

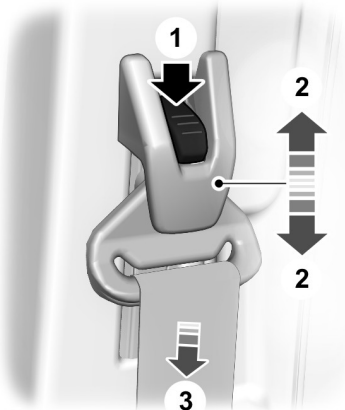

E165022

1. Press the button.
2. Slide the height adjuster up or down.
3. Release the button and pull down on the height adjuster to make sure it is locked in place.

SAFETY BELT MINDER

WARNING



The system will only provide protection when you use the safety belt correctly.

The warning lamp illuminates and an audible warning will sound when the following conditions have been met:

- The front safety belts have not been fastened.
- Your vehicle exceeds a relatively low speed.

It will also illuminate when a front safety belt is unfastened when your vehicle is moving.

Supplementary Restraints System

PRINCIPLE OF OPERATION

WARNINGS

 Extreme Hazard! Never use a rearward facing child restraint on a seat protected by an active airbag in front of it. Death or serious injury to the child can occur.

 Do not modify the front of your vehicle in any way. This could adversely affect deployment of the airbags. Failure to adhere to this warning could result in serious personal injury or death.

 Wear a safety belt and keep sufficient distance between yourself and the steering wheel. Only when you use the safety belt correctly, can it hold you in a position that allows the airbag to achieve its optimum effect. See **Sitting in the Correct Position** (page 84). Failure to adhere to this warning could result in serious personal injury or death.

 Repairs to the steering wheel, steering column, seats, airbags and safety belts must be carried out by an authorized dealer. Failure to adhere to this warning could result in serious personal injury or death.

 Keep the areas in front of the airbags free from obstruction. Do not affix anything to or over the airbag covers. In the event of a crash, hard objects could cause serious personal injury or death.

 Do not puncture the seat with sharp objects. This could damage and adversely affect deployment of the airbags. Failure to adhere to this warning could result in serious personal injury or death.

 Use seat covers designed for seats with side airbags. Have these fitted by an authorized dealer. Failure to adhere to this warning could result in serious personal injury or death.

Note: You will hear a loud bang and see a cloud of harmless powdery residue if an airbag deploys. This is normal.

Note: Only wipe airbag covers with a damp cloth.

DRIVER AIRBAG

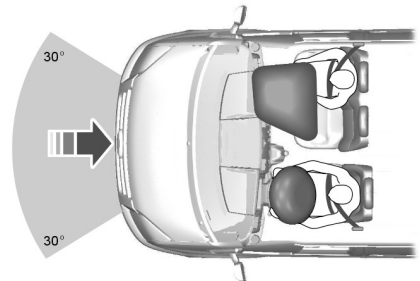

E68581

The airbag will deploy during significant frontal collisions or collisions that are up to 30 degrees from the left or the right. The airbag will inflate within a few thousandths of a second and deflate on contact with the occupant, thus cushioning forward body movement. During minor frontal collisions, overturns, rear collisions and side collisions, the airbag will not deploy.

Supplementary Restraints System

PASSENGER AIRBAG

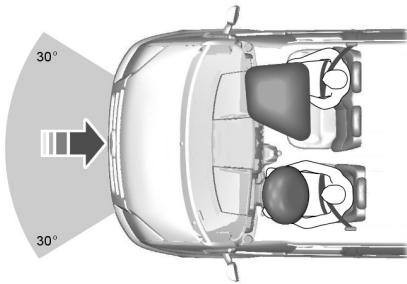

E68581

The airbag will deploy during a significant frontal crash or crashes that are up to 30 degrees from the left or the right. The airbag will inflate within a few thousandths of a second and deflate on contact with the occupant cushioning forward body movement. During minor frontal crashes, sideways crashes, rear crashes or overturns, the airbag will not deploy.

Switching the Passenger Airbag Off

WARNING



Extreme Hazard! You must switch the passenger airbag off when you are using a rearward facing child seat on the front passenger seat. Never use a rearward facing child restraint on a seat protected by an active airbag in front of it. Death or serious injury to the child can occur.

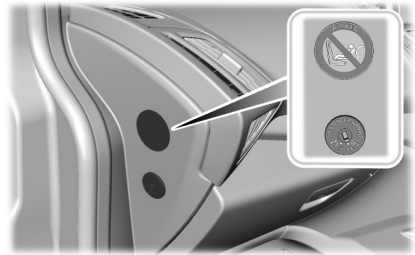

E164753

The key switch and the airbag deactivation warning lamp are located in the instrument panel.

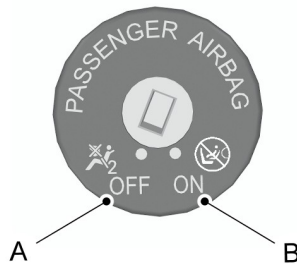

E144007

- A Switch off
- B Switch on

Turn the switch to position A.

When you switch the ignition on check that the airbag deactivation warning lamp illuminates.

Supplementary Restraints System

Switching the Passenger Airbag On

WARNING

 You must switch the passenger airbag on when you are not using a rearward child seat on the front passenger seat. Failure to adhere to this warning could result in serious personal injury or death.

Turn the switch to position B.

When you switch the ignition on check that the airbag deactivation warning lamp does not illuminate.

SIDE AIRBAGS

WARNING

 Use seat covers designed for seats with side airbags. Have these fitted by an authorized dealer.



E72658

The airbags are located inside the seatback of the front seats. There is a label attached to the side of the seatback to indicate this.

The airbag will deploy during significant lateral collisions. The airbag will not deploy in minor lateral and frontal collisions, rear collisions, or overturns.

SIDE CURTAIN AIRBAGS

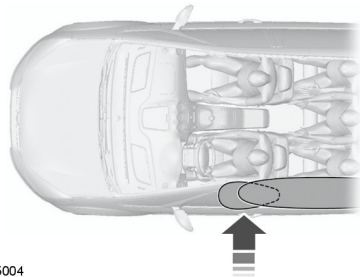

E75004

The airbags are located over the front and rear side windows.

The airbag will deploy during significant lateral collisions. It will also deploy during significant frontal angled collisions. The curtain airbag will not deploy in minor lateral and frontal collisions, rear collisions, or overturns.

Keys and Remote Controls

GENERAL INFORMATION ON RADIO FREQUENCIES

Note: Changes or modifications not expressly approved by the party responsible for compliance could void the user's authority to operate the equipment.

The typical operating range for your transmitter is approximately 33 ft (10 m).

A decrease in operating range could be caused by:

- weather conditions
- nearby radio towers
- structures around your vehicle
- other vehicles parked next to your vehicle.

The radio frequency used by your remote control can also be used by other short distance radio transmissions (e.g. amateur radios, medical equipment, wireless headphones, remote controls and alarm systems). If the frequencies are jammed, you will not be able to use your remote control. You can lock and unlock the doors with the key.

Note: Make sure your vehicle is locked before leaving it unattended.

Note: If you are in range, the remote control will operate if you press any button unintentionally.

REMOTE CONTROL

You can program a maximum of eight remote controls to your vehicle. This includes any that were supplied with your vehicle. See an authorized dealer.

Reprogramming the Unlocking Function

Note: When you press the unlock button either all the doors are unlocked or only the driver door is unlocked. Pressing the unlock button again unlocks all the doors.

Press and hold the unlock and lock buttons on the remote control simultaneously for at least four seconds with the ignition off. The direction indicators will flash twice to confirm the change.

To return to the original unlocking function, repeat the process.

Changing the Remote Control Battery



Make sure that you dispose of old batteries in an environmentally friendly way. Seek advice from your local authority regarding recycling.

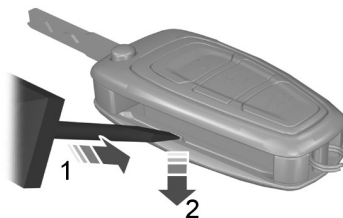

E128809

1. Insert a screwdriver in the position shown and gently push the clip.
2. Press the clip downward to release the battery cover.

Keys and Remote Controls

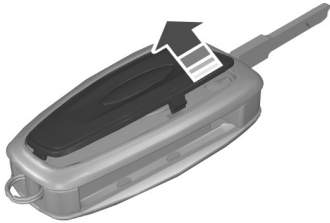

E128810

3. Carefully remove the battery cover.

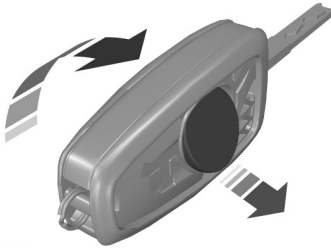

E128811

Note: Do not touch the battery contacts or the printed circuit board with the screwdriver.

4. Turn the remote control over to remove the battery.
5. Install a new battery (3V CR 2032) with the + facing upward.
6. Replace the battery cover.

REPLACING A LOST KEY OR REMOTE CONTROL

You can purchase replacement keys or remote controls from an authorized dealer. Authorized dealers can program remote controls for your vehicle. See **Remote Control** (page 32).

To re-program the passive anti-theft system see an authorized dealer.

Locks

LOCKING AND UNLOCKING

Note: Check your vehicle is locked before leaving it unattended.

Note: Do not leave your keys in your vehicle.

Locking

Locking with the Key

Turn the top of the key toward the front of your vehicle.

Locking with the Remote Control



Press the button.

Note: You can lock the driver door with the key. Use the key when the remote control is not functioning.

Double Locking

WARNING



Do not use double locking when passengers or animals are inside your vehicle. You will not be able to unlock the doors from the inside if you have double locked them.

Double locking is a theft protection feature that prevents someone from opening the doors from the inside.

Note: If you double lock your vehicle while inside, switch the ignition on to return the door locks to a single locked state.

Double Locking with the Key

Turn the key to the lock position twice within three seconds.

Double Locking with the Remote Control



Press the button twice within three seconds.

Unlocking

Unlocking with the Key

Turn the top of the key toward the rear of your vehicle.

Unlocking with the Remote Control



Press the button.

Note: You can unlock the driver door with the key. Use the key when the remote control is not functioning.

Note: When you lock your vehicle for several weeks, the remote control will be switched off. Your vehicle must be unlocked and the engine started using the key. Unlocking and starting your vehicle once will enable the remote control.

Reprogramming the Unlocking Function

You can reprogram the unlocking function so that only the driver door is unlocked. See **Remote Control** (page 32).

Locking and Unlocking Confirmation

When you lock the doors, the direction indicators will flash twice.

When you unlock the doors, the direction indicators will flash once.

Note: If your vehicle has double locking, the direction indicators will flash only when your vehicle has been double locked.

Locking and Unlocking the Doors From Inside



Press the button to lock and unlock all the doors. For item location: See **At a Glance** (page 12). The lamp illuminates with the doors locked.

Locks

Opening the Sliding Door



E164229

Opening the Double Rear Doors



E148805

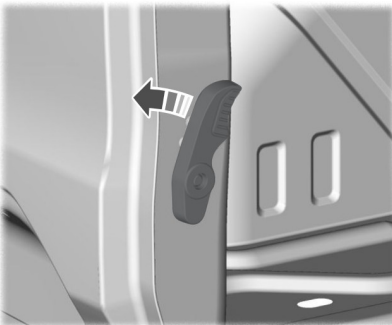

E148806

Locking the Doors Individually With the Key

Note: If the central locking function fails to operate, the doors can be individually locked using the key in the position shown.

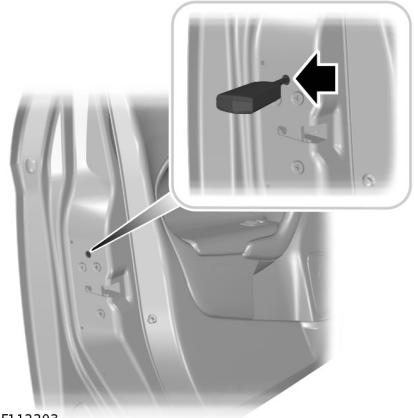

E112203

Left-hand Side

Turn clockwise to lock.

Right-hand Side

Turn counterclockwise to lock.

Automatic Locking

Your vehicle has the capability for the doors to lock automatically when you exceed 5 mph (8 km/h). You can turn this function on using the information display. See **Information Displays** (page 63). If you have turned this function on, either use the interior door unlock button or switch the ignition off and use the key or remote control to unlock the rear or sliding door.

Locks

Automatic Re-Locking

The doors will re-lock automatically if you do not open a door within 45 seconds of unlocking the doors with the remote control. The door locks and the alarm will return to their previous state.

Automatic Unlocking

You can turn this function on using the information display. See **Information Displays** (page 63). When enabled, the automatic unlocking feature will unlock all doors within 10 minutes of the end of a drive cycle, when the driver door is opened and the ignition is off.

One-Stage Unlocking

You can turn this function on using the information display. See **Information Displays** (page 63).

When you use this feature, you will unlock all doors including the rear doors or liftgate and the sliding door.

Note: *The direction indicators will flash once when you unlock the doors.*

You will unlock all of the doors when you:

- Pull either interior handle (except if you have double locked the doors).
- Turn the key in the door lock.
- Press the unlock button on the remote control once.
- Press the interior unlock button once.

Note: *When you have double locked your vehicle, the interior unlock button will only work for a period of 20 seconds.*

Two-Stage Unlocking

Note: *The direction indicators will flash once when you unlock the doors.*

You will unlock the front doors when you:

- Pull either interior handle (except if you have double locked the doors).
- Turn the key in the door lock.
- Press the unlock button on the remote control once.
- Press the interior unlock button once.

Note: *When you have double locked your vehicle, the interior unlock button will only work for a period of 20 seconds.*

You will unlock the front doors and cargo area when you:

- Turn the key in the door lock to the unlock position twice within three seconds.
- Press the unlock button on the remote control twice within three seconds.
- Press the interior unlock button twice within three seconds.

Note: *When you have double locked your vehicle, the interior unlock button will only work for a period of 20 seconds.*

Zone Re-Locking

If you enable zone re-locking and open one door, this will cause all other doors to remain locked. See an authorized dealer for further information.

The locks on Van and Kombi are split into two zones, cabin and cargo. The cargo area comprises of the rear doors or liftgate and the sliding door.

- Exit your vehicle and press the lock button.
- Press the unlock button or the luggage compartment unlock button once to open the respective zone.

If you now open a door within the unlocked zone, the other doors in that zone will automatically lock.

Locks

Configurable Unlocking

Configurable unlocking is set at the time of vehicle purchase. It allows you to select which doors unlock when you press the unlock button or the luggage compartment unlock button on your remote control once or twice. You cannot turn this feature back on if you have had it turned off. See an authorized dealer for further information.

MANUAL LIFTGATE

WARNINGS



Do not allow people to travel in any area of your vehicle that does not have seats and safety belts. Make sure everyone in your vehicle is in a seat and using a safety belt correctly. Riding in the cargo area, inside or outside of the vehicle, is extremely dangerous. In a crash, people riding in these areas are more likely to be seriously injured or even killed. Failure to follow this warning could result in serious personal injury or death.



Make sure that the liftgate is closed and latched to prevent exhaust fumes from being drawn into your vehicle. This will also prevent passengers and cargo from falling out. If you must drive with the liftgate door open, keep your vehicle well ventilated so outside air comes into your vehicle. Failure to follow this warning could result in serious personal injury.

Note: Be careful when opening or closing the liftgate in a garage or other enclosed area to avoid damaging the liftgate.

Note: Do not hang anything (bike rack, etc.) from the spoiler, glass or liftgate. This could damage the liftgate and its components.

Note: If you leave the liftgate open when driving the tailgate components could be damaged.

Opening and Closing the Liftgate

To Open the Liftgate

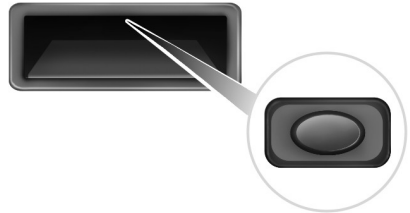

E138632

Press the button located in the top of the liftgate pull cup handle to unlatch the liftgate, then pull on the outside handle.

To Close the Liftgate



E148833

Security

PASSIVE ANTI-THEFT SYSTEM

Principle of Operation

The system prevents someone from starting the engine with an incorrectly coded key.

Note: *Do not leave correctly coded keys in the vehicle. Always take your keys and lock all doors when leaving the vehicle.*

Coded Keys

If you lose a key, you can obtain a replacement from an authorized dealer. If possible, provide them with the key number from the tag provided with the original keys. You can also obtain extra keys from an authorized dealer.

Note: *Have all of your remaining keys erased and recoded if you lose a key. Have replacement keys coded together with recoding your remaining keys. See an authorized dealer for further information.*

Note: *Do not shield your keys with metal objects. This may prevent the receiver from recognizing a coded key.*

Arming the Engine Immobilizer

When you switch the ignition off the engine immobilizer will arm automatically after a short time.

Disarming the Engine Immobilizer

When you switch the ignition on the engine immobilizer will disarm automatically if a correctly coded key is used.

If you are unable to start the engine with a correctly coded key, have your vehicle checked by an authorized dealer.

ANTI-THEFT ALARM

Alarm System

Your vehicle may have one of the following alarm systems:

- Category one alarm with interior sensors and battery back-up sounder
- perimeter alarm.

Perimeter Alarm

The perimeter alarm is a deterrent against unauthorized access to your vehicle through the doors and the hood. It also protects the audio unit.

Interior Sensors

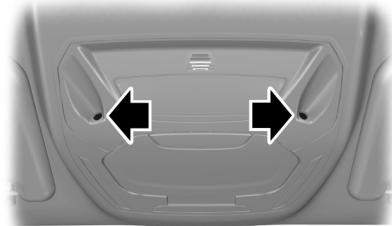

E131656

Note: *If your vehicle has a mesh bulkhead or no bulkhead the sensors will scan the complete interior. If your vehicle has any other type of bulkhead the sensors will only scan the cabin area.*

Note: *Do not cover up the interior scanning sensors.*

The sensors act as a deterrent against unauthorized intrusion by sensing any movement within your vehicle.

Security

Battery Back-up Sounder

The battery back-up sounder is an extra alarm system which will sound a siren when the alarm is triggered. When you lock your vehicle the system is armed. The sounder has its own battery and will sound an alarm siren even if someone disconnects your vehicle battery or the battery back-up sounder itself.

Triggering the Alarm

Once armed, the alarm is triggered in any of the following ways:

- If someone opens a door, the liftgate or the hood without a valid key or remote control.
- If someone removes the audio or navigation system.
- If you switch the ignition on without a valid key.
- If the interior sensors detect movement within your vehicle.
- On vehicles with a battery back-up sounder, if someone disconnects your vehicle battery or the battery back-up sounder itself.

If the alarm is triggered, the alarm horn will sound for 30 seconds and the hazard warning flashers will flash for five minutes.

Any further attempts to perform one of the above will trigger the alarm again.

Full and Reduced Guard

WARNING



Do not arm the alarm with full guard if passengers, animals or other moving objects are inside your vehicle. This could trigger the alarm.

Full Guard

Full guard is the standard setting.

In full guard, the interior sensors are on when you arm the alarm.

Note: *The auxiliary heater can trigger false alarms; always direct the airflow toward the foot well when you use the auxiliary heater. See **Climate Control** (page 73).*

Reduced Guard

In reduced guard, the interior sensors are off when you arm the alarm.

Note: *You can set the alarm to reduced guard for the current ignition cycle only. The alarm will reset to full guard the next time you switch the ignition on.*

Ask on Exit

You can set the information display to ask you each time which level of guard you wish to set.

If you select **Ask on Exit**, the message **Reduced guard** appears in the information display each time you switch the ignition off. See **Information Messages** (page 68).

If you wish to arm the alarm with reduced guard, press the **OK** button when this message appears.

If you wish to arm the alarm with full guard, leave your vehicle without pressing the **OK** button.

Selecting Full or Reduced Guard

Note: *Selecting reduced guard does not set the alarm permanently to reduced guard. It sets it to reduced guard only for the current ignition cycle. If you regularly set the alarm to reduced guard, select **Ask on Exit**.*

You can select full or reduced guard using the information display. See **General Information** (page 63).

Security

Arming the Alarm

To arm the alarm, lock your vehicle. See **Locks** (page 34).

Disarming the Alarm

Perimeter Alarm

Disarm and silence the alarm by unlocking the doors with the key and switching the ignition on with a correctly coded key or unlocking the doors with the remote control.

Category One Alarm

Disarm and silence the alarm by unlocking the doors with the key and switching the ignition on with a correctly coded key within 12 seconds or unlocking the doors with the remote control.

Wipers and Washers

WINDSHIELD WIPERS

Note: Fully defrost the windshield before switching on the windshield wipers.

Note: Make sure you switch off the windshield wipers before entering a car wash.

Note: Clean the windshield and wiper blades if they begin to leave streaks or smears. If that does not resolve the issue, install new wiper blades.

Note: Do not operate the wipers on a dry windshield. This may scratch the glass, damage the wiper blades or cause the wiper motor to burn out. Always use the windshield washers before wiping a dry windshield.

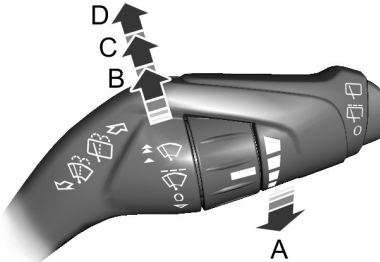

E167118

- A Single wipe
- B Intermittent wipe
- C Normal wipe
- D High speed wipe

Intermittent Wipe

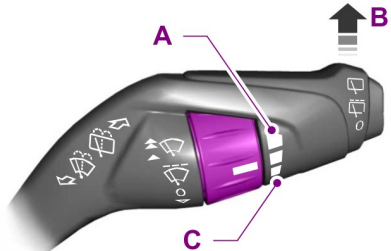

E167119

- A Short wipe interval
- B Intermittent wipe
- C Long wipe interval

Use the rotary control to adjust the intermittent wipe interval.

Speed dependent wipers (if equipped)

When your vehicle speed increases, the interval between wipes will decrease.

AUTOWIPERS

Note: Fully defrost the windshield before switching on the windshield wipers.

Note: Make sure you switch off the windshield wipers before entering a car wash.

Note: Clean the windshield and wiper blades if they begin to leave streaks or smears. If that does not resolve the issue, install new wiper blades.

Note: If you switch on the autolamps and autowipers together and the autowiper is wiping the windshield at a normal wipe speed, then the low beam headlamps will also turn on automatically.

Wipers and Washers

Note: During wet or winter driving conditions with ice, snow or a salty road mist, inconsistent or unexpected wiping or smearing may occur.

In these conditions, you can do the following:

- Lower the sensitivity of the autowipers to reduce the amount of smearing.
- Switch to normal or high-speed wipe.
- Switch the autowipers off.

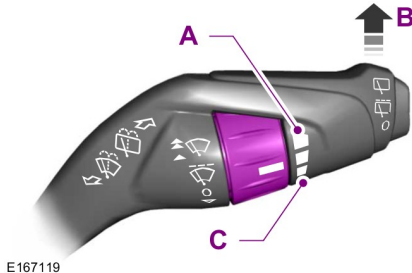

E167119

- A High sensitivity
- B On
- C Low sensitivity

The autowipers feature uses a rain sensor. You will find it in the area around the interior mirror. The rain sensor monitors the amount of moisture on the windshield and automatically turns on the wipers. It will adjust the wiper speed by the amount of moisture that the sensor detects on the windshield.

Use the rotary control to adjust the sensitivity of the rain sensor. With low sensitivity, the wipers will operate when the sensor detects a large amount of moisture on the windshield. With high sensitivity, the wipers will operate when the sensor detects a small amount of moisture on the windshield.

Keep the outside of the windshield clean because the rain sensor is very sensitive. If the area around the mirror is dirty, then the wipers may operate if dirt, mist or insects hit the windshield.

WINDSHIELD WASHERS

Note: Do not operate the washers when the washer reservoir is empty. This may cause the washer pump to overheat.

Note: Do not operate the washers for more than 10 seconds at a time.



E129188

To use the washer, pull the lever toward you. When you release the lever, the wipers will operate for a short time.

Wipers and Washers

REAR WINDOW WIPER AND WASHERS

To use the washer, push the lever away from you. When you release the lever, the wiper will operate for a short time.

Rear Window Wiper



E168043

- A Intermittent wipe
- B Low speed wipe
- C Off

Press the top of the button at the end of the lever to change between intermittent and low speed wipe. Press the bottom of the button to turn the wiper off.

When you switch on the front wipers and then shift into R (Reverse), the rear wiper will turn on automatically to intermittent wipe.

Rear Window Washer

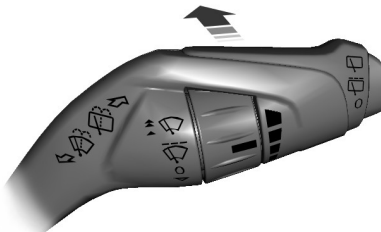

E167407

Steering Wheel

ADJUSTING THE STEERING WHEEL

WARNING

 Do not adjust the steering wheel when your vehicle is moving.

Note: Make sure that you are sitting in the correct position. See **Sitting in the Correct Position** (page 84).

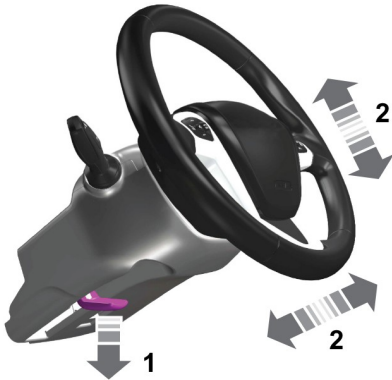

E95178

1. Unlock the steering column.
2. Adjust the steering wheel to the desired position.



E95179

3. Lock the steering column.

AUDIO CONTROL

Select the required source on the audio unit.

You can operate the following functions with the control:

Steering Wheel

Type 1

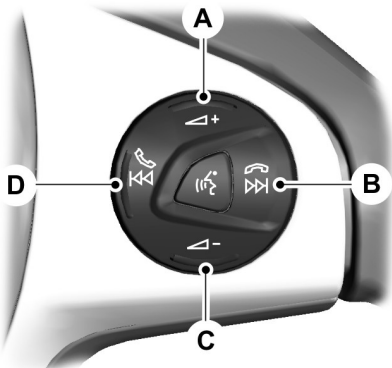

E159789

- A Volume up
- B Seek up, next or end call
- C Volume down
- D Seek down, previous or accept call

Type 2

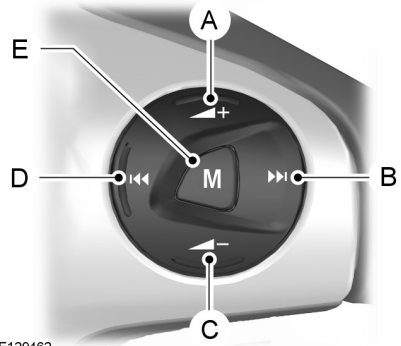

E129462

- A Volume up
- B Seek up, next or end call
- C Volume down
- D Seek down or previous
- E Mode

Press **M** to select the audio source.

Seek, Next or Previous

Press the seek button to:

- tune the radio to the next or previous stored preset
- play the next or the previous track.

Press and hold the seek button to:

- tune the radio to the next station up or down the frequency band
- seek through a track.

Steering Wheel

VOICE CONTROL



E159531

Press the button to select or deselect voice control. See **SYNC™** (page 237).

INFORMATION DISPLAY CONTROL



E130248

See **Information Displays** (page 63).

CRUISE CONTROL



E142437

See **Cruise Control** (page 128).

Lighting

GENERAL INFORMATION

Condensation in Lamp Assemblies

Exterior lamps have vents to accommodate normal changes in air pressure.

Condensation can be a natural by-product of this design. When moist air enters the lamp assembly through the vents, there is a possibility that condensation can occur when the temperature is cold. When normal condensation occurs, a fine mist can form on the interior of the lens. The fine mist eventually clears and exits through the vents during normal operation.

Clearing time may take as long as 48 hours under dry weather conditions.

Examples of acceptable condensation are:

- The presence of a fine mist (no streaks, drip marks or large droplets).
- A fine mist covers less than 50% of the lens.

Examples of unacceptable condensation are:

- A water puddle inside the lamp.
- Streaks, drip marks or large droplets present on the interior of the lens.

If you see any unacceptable condensation, have your vehicle checked by an authorized dealer.

LIGHTING CONTROL

Lighting Control Positions



E142449

- A Off
- B Parking lamps, instrument panel lamps, license plate lamps and tail lamps
- C Headlamps

Parking Lamps

Note: Prolonged use of the parking lamps will cause the battery to run out of charge.

Switch the ignition off.

Both Sides

Set the lighting control to position B.

Lighting

One Side

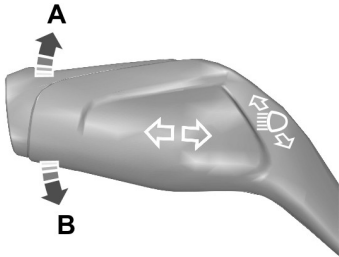

E163717

- A Right-hand side
- B Left-hand side

High Beams

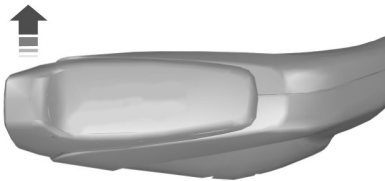

E163718

Push the lever forward to switch the high beams on.

Push the lever forward again or pull the lever toward you to switch the high beams off.

Headlamp Flasher

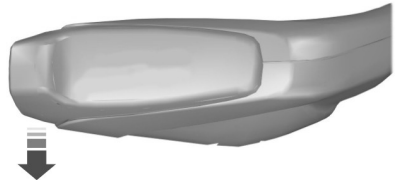

E163719

Pull the lever toward you slightly and release it to flash the headlamps.

Home Safe Lighting

Switching the System On

Switch the ignition off and pull the direction indicator lever toward the steering wheel. A tone will sound.

Switching the System Off

It will turn off automatically after three minutes with a door open or 30 seconds after the last door closes. Alternatively, pull the direction indicator lever toward the steering wheel or switch the ignition on.

AUTOLAMPS



E142451

Lighting

The headlamps will switch on and off automatically in low light situations or during inclement weather.

The headlamps will remain on for a period of time after you switch the ignition off. Use the information display controls to adjust the period of time that the headlamps will remain on. See **Information Displays** (page 63).

When the headlamp switch is in the Autolamps position, the windshield wiper activated exterior lamps will turn on within 10 seconds when you switch the windshield wipers on. The exterior lamps will turn off approximately 60 seconds after you switch the windshield wipers off.

This feature does not turn on the exterior lamps:

- during a mist wipe
- while the wipers are on to clear washer fluid during a wash condition
- if the wipers are in automatic or intermittent modes.

Note: *If you have autolamps and autowipers switched on the low beam headlamps will turn on automatically when the windshield wipers operate continuously.*

Note: *You may have to manually switch the headlamps on in severe weather conditions.*

Note: *If you have autolamps switched on you can only switch the high beam headlamps on once the system has turned the headlamps on.*

INSTRUMENT LIGHTING DIMMER

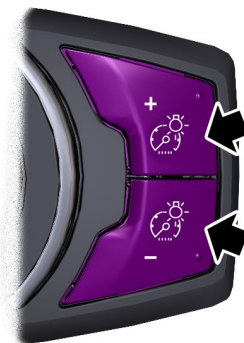

E132712

Press it repeatedly or press it and hold it until the desired level is reached.

Note: *If you disconnect the battery or it loses charge the instrument lighting will return to its brightest setting.*

HEADLAMP EXIT DELAY

After you switch the ignition off, you can switch the headlamps on by pulling the direction indicator lever toward you. You will hear a short tone. The headlamps will switch off automatically after three minutes with any door open or 30 seconds after the last door has been closed. You can cancel this feature by pulling the direction indicator toward you again or switching the ignition on.

Lighting

DAYTIME RUNNING LAMPS

WARNING

 Always remember to switch your headlamps on in low light situations or during inclement weather. The system does not activate the tail lamps and may not provide adequate lighting during these conditions. Failure to activate your headlamps under these conditions may result in a collision.

To switch the system on:

1. Switch the ignition on.
2. Switch the lighting control to the off or autolamp position.

FRONT FOG LAMPS



E132709

Press the control to switch the fog lamps on or off.

You can switch the fog lamps on when the lighting control is in any position except off.

Note: Only use fog lamps during reduced visibility, for example, fog, snow or heavy rain.

Note: If you switch autolamps on, you can only switch the fog lamps on once autolamps has turned the headlamps on.

REAR FOG LAMPS



E132710

Press the control to switch the fog lamps on or off.

You can only switch the rear fog lamps on when either the front fog lamps or low beam headlamps are on.

Note: Only use the rear fog lamps when visibility is less than 164 feet (50 meters).

Note: Do not use the rear fog lamps when it is raining or snowing.

Note: If you switch autolamps on, you can only switch the fog lamps on once autolamps has turned the headlamps on.

HEADLAMP LEVELING

Adjust the level of the headlamp beams according to your vehicle load.

Set the headlamp leveling control to zero when your vehicle is unloaded. Set the headlamp beams to give between 115 feet and 330 feet (35 meters and 100 meters) of road surface illumination when your vehicle is partially or fully loaded.

Lighting

To adjust the level of the headlamp beams:

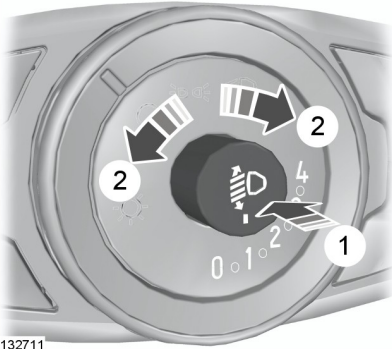

E132711

1. Press to release the control.
2. Rotate the control to the required setting.
3. Press to close the control.

CORNERING LAMPS

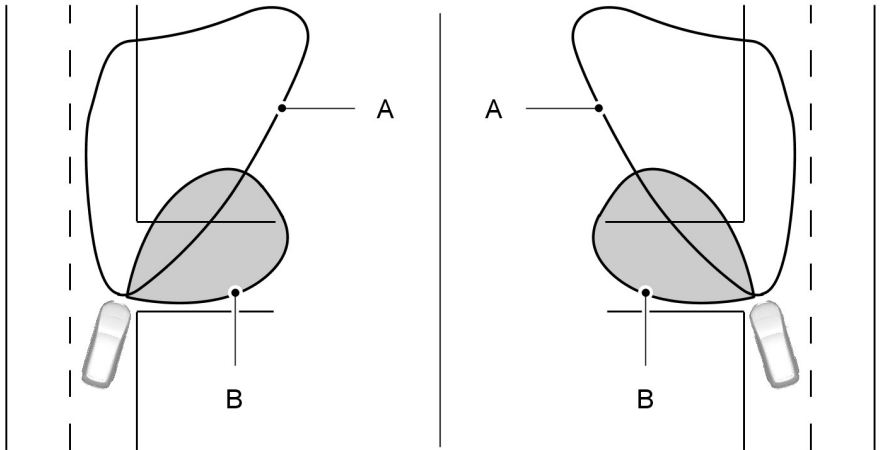

E72898

- A Headlamp beam
- B Cornering lamp beam

Lighting

The cornering lamps illuminate the inside of a corner when you are turning.

DIRECTION INDICATORS



E162681

Push the lever up or down to use the direction indicators.

Note: Tap the lever up or down to make the direction indicators flash three times to indicate a lane change.

INTERIOR LAMPS

Courtesy Lamp

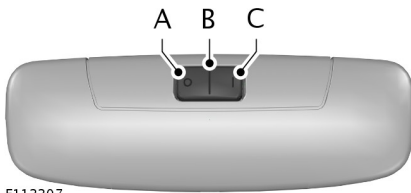

E112207

- A Off
- B Door contact
- C On

If you set the switch to position B, the courtesy lamp will switch on when you unlock your vehicle, open a door or the liftgate. If you leave a door open with the ignition switched off, the courtesy lamp will switch off automatically after a short period of time to prevent your vehicle battery from losing charge. To switch it back on, switch the ignition on for a short period of time.

The courtesy lamp will also switch on when you switch the ignition off. It will switch off automatically after a short period of time or when you start the engine.

If you set the switch to position C with the ignition switched off, the courtesy lamp will switch on. It will switch off automatically after a short period of time to prevent your vehicle battery from losing charge. To switch it back on, switch the ignition on for a short period of time.

Reading Lamps



E112208

If you switch the ignition off, the reading lamps will switch off automatically after a short period of time to prevent your vehicle battery from losing charge. To switch them back on, switch the ignition on for a short period of time.

Luggage Compartment Lamp

The luggage compartment lamp will switch on and off automatically when you open and close the doors. If you unlock the doors with the remote control, they will switch on. They will switch off automatically after a short period of time.

Windows and Mirrors

POWER WINDOWS - VEHICLES WITH: ONE-TOUCH DOWN DRIVER WINDOW

WARNINGS

 Do not leave children unattended in your vehicle and do not let them play with the power windows. They may seriously injure themselves.

 When closing the power windows, you should verify they are free of obstructions and make sure that children and pets are not in the proximity of the window openings.



E166915

Note: You may hear a pulsing noise when just one of the windows is open. Lower the opposite window slightly to reduce this noise.

Press the switch to open the window.

Lift the switch to close the window.

One-Touch Down (If Equipped)

Press the switch fully and release it. Press again or lift it to stop the window.

Accessory Delay (If Equipped)

You can use the window switches for several minutes when you switch the ignition off or until you open either front door.

POWER WINDOWS - VEHICLES WITH: REAR POWER WINDOWS

WARNINGS

 Do not leave children unattended in your vehicle and do not let them play with the power windows. They may seriously injure themselves.

 When closing the power windows, you should verify they are free of obstructions and make sure that children and pets are not in the proximity of the window openings.

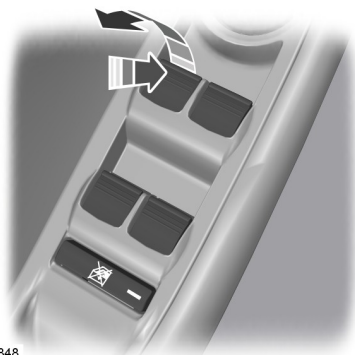

E70848

Note: You may hear a pulsing noise when just one of the windows is open. Lower the opposite window slightly to reduce this noise.

Press the switch to open the window.

Lift the switch to close the window.

Windows and Mirrors

One-Touch Down (If Equipped)

Press the switch fully and release it. Press again or lift it to stop the window.

One-Touch Up (If Equipped)

Lift the switch fully and release it. Press or lift it again to stop the window.

Window Lock



E70850

Press the control to lock or unlock the rear window controls. It will illuminate when the rear window controls are locked.

Bounce-Back (If Equipped)

The window will stop automatically while closing. It will reverse some distance if there is an obstacle in the way.

Overriding the Bounce-Back Feature

WARNING

 When you override the bounce-back feature the window will not reverse if it detects an obstacle. Take care when closing the windows to avoid personal injury or damage to your vehicle.

Proceed as follows to override this protection feature when there is a resistance, for example in winter:

1. Close the window twice until it reaches the point of resistance and let it reverse.
2. Close the window a third time to the point of resistance. The bounce-back feature is now disabled and you can close the window manually. The window will go past the point of resistance and you can close it fully.

See an authorized dealer as soon as possible if the window does not close after the third attempt.

Resetting the Bounce-Back Feature

WARNING



The bounce-back feature remains turned off until you reset the memory.

If you have disconnected the battery, you must reset the bounce-back memory separately for each window.

1. Lift and hold the switch until the window is fully closed.
2. Release the switch.
3. Lift the switch again for one more second.
4. Press and hold the switch until the window is fully open.
5. Release the switch.
6. Lift and hold the switch until the window is fully closed.
7. Open the window and then try to close it automatically.
8. Reset and repeat the procedure if the window does not close automatically.

Windows and Mirrors

Accessory Delay (If Equipped)

You can use the window switches for several minutes after you have switched the ignition off or until either front door is opened.

EXTERIOR MIRRORS

Power Exterior Mirrors (If Equipped)

WARNING



Do not adjust the mirrors when your vehicle is moving. This could result in the loss of control of your vehicle, serious personal injury or death.

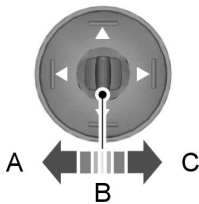

E70846

- A Left-hand mirror
- B Off
- C Right-hand mirror

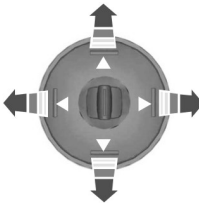

E70847

Press the arrows to adjust the mirror.

Note: Do not clean the housing or glass of any mirror with harsh abrasives, fuel or other petroleum or ammonia-based cleaning products.

Automatic Folding and Unfolding

The mirrors will automatically fold or unfold when you use the key to lock or unlock your vehicle.

Note: If you fold the mirrors using the manual fold button, you can only unfold them again manually.

Manual Folding and Unfolding

The power folding mirrors operate with the ignition on, and for several minutes after you switch the ignition off.

Note: You can only fold the mirrors when the controller is set to position B.

Note: Continuous folding and unfolding of the mirrors will cause them to overheat and shut down for a short time. This is to avoid permanent damage.



E165480

Press the down arrow to fold or unfold the mirrors.

Press the down arrow again to stop and reverse the direction of movement.

Note: Continuous folding and unfolding of the mirrors will cause them to overheat and shut down for a short time. This is to avoid permanent damage.

Windows and Mirrors

Fold Away Exterior Mirrors

Push the mirror toward the door window glass. Make sure that you fully engage the mirror in its support when returning it to its original position.

INTERIOR MIRROR

WARNING



Do not adjust the mirror when your vehicle is moving.

Note: Do not clean the housing or glass of any mirror with harsh abrasives, fuel or other petroleum or ammonia-based cleaning products.

You can adjust the interior mirror to your preference. Some mirrors also have a second pivot point. This lets you move the mirror head up or down and from side to side.

Pull the tab below the mirror toward you to reduce glare at night.

Auto-Dimming Mirror (If Equipped)

Note: Do not block the sensors on the front and back of the mirror. Mirror performance may be affected. A rear center passenger or raised rear center head restraint may also block light from reaching the sensor.

The mirror will dim automatically to reduce glare when bright lights are detected from behind your vehicle. It will automatically return to normal reflection when you select reverse gear to make sure you have a clear view when backing up.

GLOBAL OPENING AND CLOSING

You can also operate the power windows with the ignition off using the global opening and global closing function.

Note: Global opening will only operate for a short period of time after you have unlocked your vehicle using the remote control.

Note: Global closing will only operate if you have set the memory correctly for each window. See **Power Windows** (page 53).

Global Opening

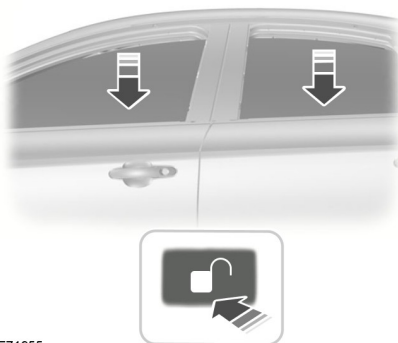

E71955

To open all the windows:

1. Press and release the remote control unlock button.
2. Press and hold the remote control unlock button for at least three seconds.

Press the lock or unlock button to stop the opening function.

Windows and Mirrors

Global Closing

WARNING

 Take care when using global closing. Failure to follow this warning could seriously increase the risk of injury or death. In an emergency, press the lock or unlock button immediately to stop.

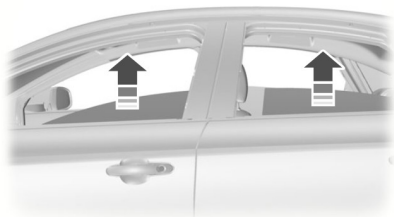

E71956

To close all the windows, press and hold the remote control lock button for at least three seconds. Press the lock or unlock button to stop the closing function. The bounce-back function is also on during global closing.

Instrument Cluster

GAUGES

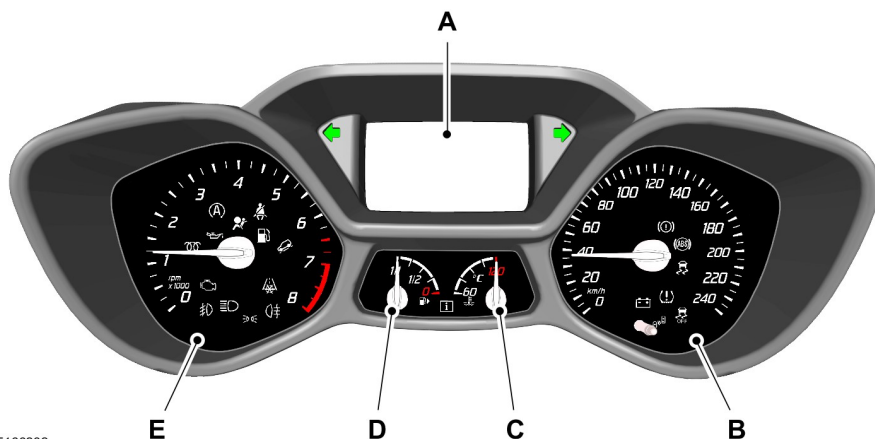

E166232

- A Information display
- B Speedometer
- C Engine coolant temperature gauge
- D Fuel gauge
- E Tachometer

Information Display

Odometer

Located in the bottom of the information display, it registers the accumulated distance your vehicle has traveled.

Outside Air Temperature

Shows the outside air temperature.

Trip Computer

See **Trip Computer** (page 67).

Vehicle Settings and Personalization

See **Personalized Settings** (page 67).

Engine Coolant Temperature Gauge

WARNING



Never remove the coolant reservoir cap while the engine is running or hot. Steam and scalding liquids released from a hot cooling system can cause burns.

At normal operating temperature, the needle will remain in the center section.

Instrument Cluster

If the needle enters the red section, the engine is overheating. Stop the engine, switch the ignition off and determine the cause once the engine has cooled down. See **Engine Coolant Check** (page 167).

Note: Do not restart the engine until the cause of overheating has been resolved.

Fuel Gauge

Switch the ignition on. The fuel gauge will indicate approximately how much remains in the fuel tank. The fuel gauge may vary slightly when your vehicle is moving or on a gradient. The arrow adjacent to the fuel pump symbol indicates on which side of the vehicle the fuel filler door is located.

WARNING LAMPS AND INDICATORS

The following warning lamps and indicators will alert you to a vehicle condition that may become serious. Some lamps will illuminate when you start your vehicle to make sure they work. If any lamps remain on after starting your vehicle, refer to the respective system warning lamp for further information.

Note: Some warning indicators appear in the information display and function the same as a warning lamp but do not display when you start your vehicle.

Anti-Lock Braking System Warning Lamp



If it illuminates when you are driving, this indicates a malfunction. You will continue to have the normal braking system (without anti-lock braking system) unless the brake system warning lamp is also illuminated. Have your vehicle checked by an authorized dealer.

Battery Warning Lamp



If it illuminates when driving, this indicates a malfunction. Switch off all unnecessary electrical equipment. Have your vehicle checked by an authorized dealer immediately.

Brake System Warning Lamp



It will illuminate when you engage the parking brake with the ignition on.

If it illuminates when you are driving, check that the parking brake is not engaged. If the parking brake is not engaged, this indicates low brake fluid level or a brake system malfunction. Have your vehicle checked by an authorized dealer immediately.

WARNING



Driving your vehicle with the warning lamp on is dangerous. A significant decrease in braking performance may occur. It will take you longer to stop your vehicle. Have your vehicle checked by an authorized dealer immediately. Driving extended distances with the parking brake engaged can cause brake failure and the risk of personal injury.

Cruise Control Indicator



It will illuminate when you switch this feature on. See **Using Cruise Control** (page 128).

Direction Indicator



Illuminates when the left or right direction indicator or the hazard warning flasher is turned on. If the indicators stay on or flash faster, check for a burnt out bulb. See **Changing a Bulb** (page 170).

Instrument Cluster

Engine Oil Warning Lamp

WARNING



Do not resume your journey if it illuminates despite the level being correct. Have your vehicle checked by an authorized dealer immediately.



If it illuminates with the engine running or when you are driving, this indicates a malfunction. Stop your vehicle as soon as it is safe to do so and switch the engine off. Check the engine oil level. See **Engine Oil Check** (page 166).

Engine Warning Lamps



Malfunction Indicator Lamp



Powertrain Warning Lamp

All Vehicles

If either lamp illuminates when the engine is running, this indicates a malfunction. The engine will continue to run but it may have limited power. If it flashes when you are driving, reduce the speed of your vehicle immediately. If it continues to flash, avoid heavy acceleration or deceleration. Have your vehicle checked by an authorized dealer immediately.

WARNING



Have this checked immediately.

If both lamps illuminate together, stop your vehicle as soon as it is safe to do so (continued use may cause reduced power and cause the engine to stop). Switch the ignition off and attempt to restart the engine. If the engine restarts have your vehicle checked by an authorized dealer immediately. When the engine does not restart have your vehicle checked by an authorized dealer.

Fasten Safety Belt Warning Lamp



It will illuminate and a chime will sound to remind you to fasten your safety belt. See **Safety Belt Minder** (page 28).

Front Airbag Warning Lamp



If it fails to illuminate when you start your vehicle, continues to flash or remains on, it indicates a malfunction. Have your vehicle checked by an authorized dealer.

Front Fog Lamps Indicator



It will illuminate when you switch the front fog lamps on.

Frost Warning Lamp

WARNING



Even if the temperature rises to above +4°C (39°F) there is no guarantee that the road is free of hazards caused by inclement weather.



It will illuminate and glow amber when the outside air temperature is between +4°C (39°F) and 0°C (32°F). It will glow red when the temperature is below 0°C (32°F).

Instrument Cluster

Glow Plug Indicator



See **Starting a Diesel Engine** (page 99).

High Beam Indicator



It will illuminate when you switch the high beam headlamps on. It will flash when you use the headlamp flasher.

Information Indicator



It will illuminate when a new message is stored in the information display. It will be red or amber in color depending on the severity of the message and will remain on until the cause of the message has been rectified. See **Information Messages** (page 68).

Low Fuel Level Warning Lamp



If it illuminates, refuel as soon as possible.

Headlamp and Parking Lamp Indicator



It will illuminate when you switch the headlamps or parking lamps on.

Rear Fog Lamps Indicator



It will illuminate when you switch the rear fog lamps on.

Shift Indicator



It will illuminate to inform you that shifting to a higher or lower gear as indicated may give better fuel economy and lower CO2 emissions. It will not illuminate during periods of high acceleration, braking or when the clutch pedal is pressed.



Stability Control Off Indicator



It will illuminate when you switch the system off. It will go out when you switch the system back on or when you switch the ignition off.

Stability Control Warning Lamp



It will flash when the system is active. If it remains illuminated or does not illuminate when you switch the ignition on, this indicates a malfunction. During a malfunction the system will switch off. Have your vehicle checked by an authorized dealer immediately.

Start-Stop Indicator



It will illuminate to inform you when the engine shuts down or in conjunction with a message. See **Auto-Start-Stop** (page 102). See **Information Messages** (page 68).

Instrument Cluster

AUDIBLE WARNINGS AND INDICATORS - VEHICLES WITH: AUTOMATIC TRANSMISSION

Key in Ignition Warning Chime

Sounds when you open the driver door and you have left the key in the ignition with it in the off or accessory position.

Headlamps On Warning Chime

Sounds when you remove the key from the ignition and open the driver door and you have left the headlamps or parking lamps on.

Parking Brake On Warning Chime

Sounds when you have left the parking brake on and drive your vehicle. If the warning chime remains on after you have released the parking brake, have your vehicle checked by an authorized dealer immediately.

Automatic Transmission Warning Chime

Sounds when you have not moved the transmission selector lever to park. A message will be shown in the display.

AUDIBLE WARNINGS AND INDICATORS - VEHICLES WITH: MANUAL TRANSMISSION

Key in Ignition Warning Chime

Sounds when you open the driver door and you have left the key in the ignition with it in the off or accessory position.

Headlamps On Warning Chime

Sounds when you remove the key from the ignition and open the driver door and you have left the headlamps or parking lamps on.

Parking Brake On Warning Chime

Sounds when you have left the parking brake on and drive your vehicle. If the warning chime remains on after you have released the parking brake, have your vehicle checked by an authorized dealer immediately.

Information Displays

GENERAL INFORMATION

WARNING



Driving while distracted can result in loss of vehicle control, crash and injury. We strongly recommend that you use extreme caution when using any device that may take your focus off the road. Your primary responsibility is the safe operation of your vehicle. We recommend against the use of any handheld device while driving and encourage the use of voice-operated systems when possible. Make sure you are aware of all applicable local laws that may affect the use of electronic devices while driving.

Information Display Controls



E138659

You can use the information display control on the steering wheel to adjust various system settings on your vehicle. The instrument panel will display the system settings.

- Press the up or down arrow buttons to scroll through and highlight the options within a menu.
- Press the right arrow button to enter a submenu.
- Press the left arrow button to exit a submenu.
- Press the **OK** button to choose and confirm settings or messages.

Menu Structure - Information Display

Note: Some options may appear slightly different or not at all if the items are optional.

Trip computer ¹
Trip odometer
Dist to empty
Instant fuel
Average fuel

Information Displays

Trip computer¹
Average speed
All values

¹ See **Trip Computer** (page 67).

Settings		
Lighting	Rain light	On or Off
	Auto highbeam	On or Off
	Hdlamp delay	Manual or xx Seconds
Display	Language	Choose your applicable setting
	Measure unit	Choose your applicable setting
	Temp unit	Choose your applicable setting
Chimes	Information	On or Off
	Warning	On or Off
Convenience	Aux heater	On or Off
	Park heater	Time 1
		Time 2
		Once
		Heat now
	Locks	Auto lock
		Auto unlock
		Global unlock
		Custom locking
		Full guard

Information Displays

Settings	
	Alarm system
	Reduced guard
	Ask on exit
System reset	Hold OK to Reset System to Factory Default

System Check

Active warnings will display first. The system check menu may appear different based upon equipment options and current vehicle status. Press the up or down arrow buttons to scroll through the list.

Menu Structure - Information and Entertainment Display

SYNC-Media allows you to access the SYNC features.

Note: *Some options may appear slightly different or not at all if the items are optional.*

SYNC-Phone	
Dial a number	
Redial	
Phonebook	
Call history	Incoming calls
	Outgoing calls
	Missed calls
Speed Dial	
Text messaging	
BT Devices	
Phone settings	Set as master
	Phonebook pref.
	Set ringtone
	Phone status
	Text msg notify
Emerg. Assist.	

Information Displays

Menu	
SYNC-Settings	Bluetooth on
	Set defaults
	Master reset
	Install on SYNC
	System info
	Voice settings
	Browse USB
SYNC-Apps	
Audio settings	Adaptive volume
	Sound
	DSP settings
	DSP equaliser
	TA
	News
	Alt. frequency
	RDS regional
	DAB service link
Vehicle settings	Traction Control
	ESC
	Hill start assist
	Alarm system
	Powerfold mirrors
	Indicator
	Chimes
Clock settings	Auto time (GPS)
	Set time

Information Displays

Menu	
	Set date
	Set time zone
	Summer time
	24-hour mode

CLOCK

Type 1

To adjust the clock, switch the ignition on and press buttons H or M on the information and entertainment display as necessary.

Type 2

Note: Use the information display to adjust the clock. See **General Information** (page 63).

TRIP COMPUTER

Resetting the Trip Computer

Press and hold **OK** on the current screen to reset the respective trip, distance, time and average fuel information.

Trip Odometer

Registers the distance traveled of individual journeys.

Distance to Empty

Indicates the approximate distance your vehicle will travel on the fuel remaining in the tank. Changes in driving pattern may cause the value to vary.

Average Fuel

Indicates the average fuel consumption since the function was last reset.

PERSONALIZED SETTINGS

Measure Units

To swap between imperial and metric units, scroll to this display and press the **OK** button.

Swapping between imperial and metric units will affect the following displays:

- Distance to empty.
- Average fuel consumption.
- Instantaneous fuel consumption.
- Average speed.

Switching Chimes Off

The following chimes can be switched off:

- Warning messages.
- Information messages.

Information Displays

INFORMATION MESSAGES



E130248

Press the **OK** button to acknowledge and remove some messages from the information display. Other messages will be removed automatically after a short time.

Certain messages need to be confirmed before you can access the menus.

 The message indicator illuminates to supplement some messages. It will be red or amber depending on the severity of the message and will remain on until the cause of the message has been rectified.

Some messages will be supplemented by a system specific symbol with a message indicator.

Note: *Depending on the options on your vehicle, not all of the messages will display or be available. Certain messages may be abbreviated or shortened depending upon which instrument cluster type you have.*

Airbag

Message	Message Indicator	Action
Airbag fault Service now	Amber	Have your vehicle checked by an authorized dealer as soon as possible.

Alarm

Message	Message Indicator	Action
Alarm activated Check Vehicle	Amber	Displays when the alarm has been triggered due to unauthorized entry. See Anti-Theft Alarm (page 38).
Alarm fault Service required	-	Have your vehicle checked by an authorized dealer as soon as possible.

Information Displays

Battery and Charging System

Message	Message Indicator	Action
Electrical system over-voltage Stop safely	Red	Stop your vehicle as soon as it is safe to do so and switch the ignition off. Have your vehicle checked by an authorized dealer as soon as possible.
Battery low See manual	Amber	Displays to warn of a low battery condition. Turn off all unnecessary electrical accessories. Have your vehicle checked by an authorized dealer as soon as possible.

Doors Open

Message	Message Indicator	Action
Driver door open	Red	Vehicle is moving. Stop your vehicle as soon as safely possible and close.
Driver side rear door open	Red	Vehicle is moving. Stop your vehicle as soon as safely possible and close.
Passenger door open	Red	Vehicle is moving. Stop your vehicle as soon as safely possible and close.
Passenger side rear door open	Red	Vehicle is moving. Stop your vehicle as soon as safely possible and close.
Hood open	Red	Vehicle is moving. Stop your vehicle as soon as safely possible and close.
Rear load compartment door open	Red	Vehicle is moving. Stop your vehicle as soon as safely possible and close.
Emergency rear door open	Red	Vehicle is moving. Stop your vehicle as soon as safely possible and close.
Driver door open	-	Vehicle not moving. Close.
Driver side rear door open	-	Vehicle not moving. Close.
Passenger door open	-	Vehicle not moving. Close.
Passenger side rear door open	-	Vehicle not moving. Close.

Information Displays

Message	Message Indicator	Action
Hood open	-	Vehicle not moving. Close.
Rear load compartment door open	-	Vehicle not moving. Close.
Emergency rear door open	-	Vehicle not moving. Close.

Engine

Message	Message Indicator	Action
Engine fault Service now	Amber	Have your vehicle checked by an authorized dealer as soon as possible.
High engine temperature Stop safely	Red	Displays when the engine temperature is too high. Stop your vehicle as soon as it is safe to do so, switch the ignition off and allow the engine to cool. If the problem persists, have your vehicle checked by an authorized dealer as soon as possible. See Engine Coolant Check (page 167).

Hill Start Assist

Message	Message Indicator	Action
Hill start assist not available	Amber	Displays when hill start assist is not available. Have your vehicle checked by an authorized dealer as soon as possible. See Hill Start Assist (page 119).

Information Displays

Lighting

Message	Message Indicator	Action
Brake lamp Bulb fault	-	Displays when the brake lamp bulb has burned out. See Changing a Bulb (page 170).
Low beam Bulb fault	-	Displays when the low beam headlamp bulb has burned out. See Changing a Bulb (page 170).
Headlamp fault Service required	Amber	Displays when an electrical system problem occurs with the headlamp system. Have your vehicle checked by an authorized dealer as soon as possible.

Maintenance

Message	Message Indicator	Action
Oil change required	-	Displays when the engine oil life is depleted and requires a change. See Engine Oil Check (page 166).
Brake fluid level low Service now	Red	Indicates the brake fluid level is low and the brake system should be inspected immediately. See Brake and Clutch Fluid Check (page 167). Have your vehicle checked by an authorized dealer as soon as possible.
Washer fluid level low	-	Displays when the washer fluid is low and needs to be refilled. See Washer Fluid Check (page 168).

Parking Aid

Message	Message Indicator	Action
Parking aid fault Service required	Amber	Displays when the system has detected a fault that requires service. Have your vehicle checked by an authorized dealer as soon as possible. See (page 123).

Information Displays

Parking Brake

Message	Message Indicator	Action
Park brake applied	Red	Displays when the parking brake is set, the engine is running and your vehicle speed is above 3 mph (5 km/h). If the warning stays on after the parking brake is released, have your vehicle checked by an authorized dealer as soon as possible.

Starting System

Message	Message Indicator	Action
Press brake to start	-	Displays when you start your vehicle as a reminder to apply the brake.
Cranking time exceeded	-	Displays when your vehicle fails to start.

Traction Control

Message	Message Indicator	Action
Traction control off	-	Displays when you switch the traction control system off. See Using Traction Control (page 121).

Climate Control

PRINCIPLE OF OPERATION

Outside Air

Keep the air intakes in front of the windshield free from obstruction (such as snow or leaves) to allow the climate control system to function effectively.

Recirculated Air

WARNING



Prolonged use of recirculated air may cause the windows to mist up. If the windows mist up, follow the settings for demisting the windshield.

The air currently in the passenger compartment recirculates. Outside air does not enter your vehicle.

Heating

Heating performance depends on the temperature of the engine coolant.

Air Conditioning

Note: The air conditioning operates only when the temperature is above 39°F (4°C).

Note: When you use air conditioning, your vehicle uses more fuel.

The system directs air through the evaporator for cooling. The evaporator extracts humidity from the air to help keep the windows free of mist. The system directs the resulting condensation to the outside of your vehicle, which may cause a small pool to form under your vehicle. This is normal.

General Information on Controlling the Interior Climate

Fully close all the windows.

Warming the Interior

Direct the air toward your feet. In cold or humid weather conditions, direct some of the air toward the windshield and the door windows.

Cooling the Interior

Direct the air toward your face.

AIR VENTS

Center Air Vents

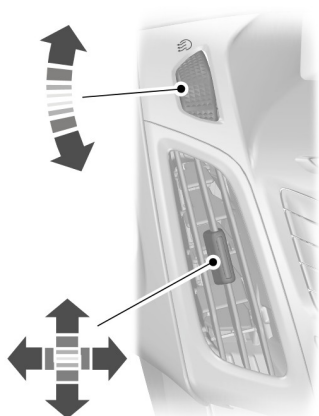

E132995

To close the air vent turn the airflow dial to the closed position.

Climate Control

Side Air Vents

To close the air vent slide the airflow direction control down.



E163442

MANUAL CLIMATE CONTROL

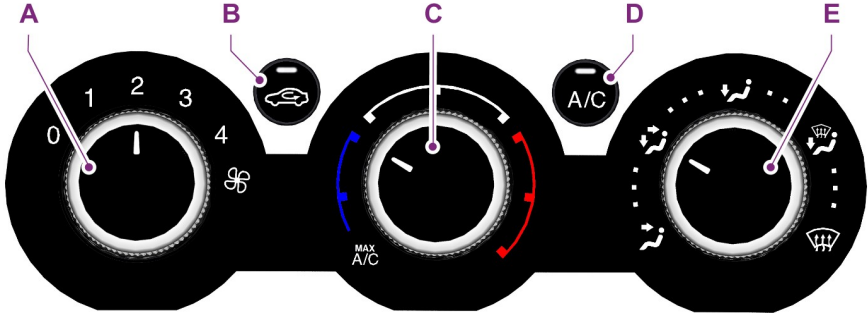

E141421

Climate Control

- A **Fan speed control:** Controls the volume of air circulated in your vehicle. Adjust to select the desired fan speed or switch off. If you switch the fan off, the windshield may fog up.
- B **Recirculated air:** Press the button to switch between outside air and recirculated air. When you select recirculated air, the button illuminates and the air currently in the passenger compartment recirculates. This can reduce the time needed to cool the interior and reduce unwanted odors from entering your vehicle.
- C **Temperature control:** Controls the temperature of the air circulated in your vehicle. Adjust to select the desired temperature. If you select **MAX A/C**, the system distributes recirculated air through the instrument panel air vents. This mode is more economical and efficient than normal air conditioning. When the temperature control is in the **MAX A/C** position, the air conditioning or recirculated air can be turned on and off.
- D **Air conditioning:** Press the button to switch the air conditioning on or off. Air conditioning cools your vehicle using outside air. To improve the performance of the air conditioning, drive with the windows slightly open for the first two or three minutes.
- E **Air distribution control:** Adjust to select the desired air distribution.



Select to distribute air through the instrument panel air vents.



Select to distribute air through the instrument panel and footwell air vents.



Select to distribute air through the footwell air vents.



Select to distribute air through the windshield and footwell air vents.



Select to distribute air through the windshield air vents. You can also use this setting to defog and clear the windshield of a thin covering of ice. You can also increase the temperature and fan speed to improve clearing.

When the temperature is above 4°C (39°F), the air conditioning will switch on automatically. Make sure that the blower is on. The indicator in the switch will illuminate during defrosting and demisting.

Climate Control

AUTOMATIC CLIMATE CONTROL

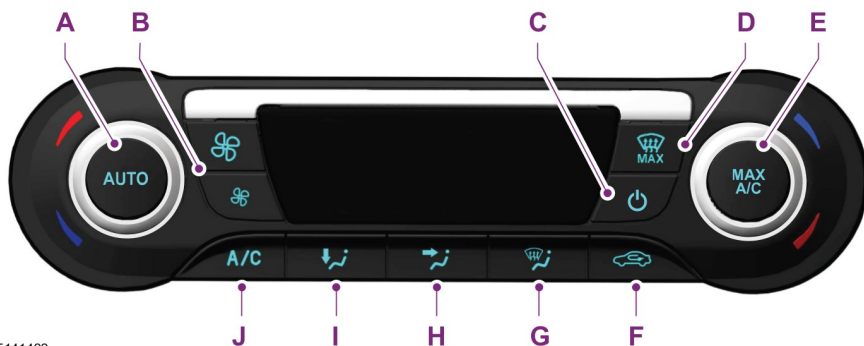

E141422

- A **AUTO:** Press the button to select automatic operation. The system automatically controls the temperature, amount and distribution of the airflow to reach and maintain your previously selected temperature.
- B **Fan speed:** Controls the volume of air circulated in your vehicle. Press the buttons to select the desired fan speed. The setting is shown in the display.
- C **On and off button:** Press the button to switch the system on and off.
- D **MAX Defrost:** Press the button to distribute outside air through the windshield air vents. Air conditioning is automatically selected. The fan is set to the highest speed and the temperature to HI. When the air distribution is set in this position you are unable to select recirculated air or manually adjust the temperature control. Press the **AUTO** button to return to auto mode.
- E **MAX A/C:** Press the button to distribute maximum air conditioning through the instrument panel air vents. This mode is more economical and efficient than normal air conditioning.
- F **Recirculated air:** Press the button to switch between outside air and recirculated air. The air currently in the passenger compartment recirculates. This can reduce the time needed to cool the interior and reduce unwanted odors from entering your vehicle.
- G **Defrost:** Press the button to distribute air through the windshield air vents. You can also use this setting to defog and clear the windshield of a thin covering of ice.
- H **Instrument panel:** Press the button to distribute air through the instrument panel air vents.

Climate Control

- I **Footwell:** Press the button to distribute air through the footwell air vents.
- J **Air conditioning:** Press the button to switch the air conditioning on or off. Air conditioning cools your vehicle using outside air. To improve air conditioning when starting your vehicle, drive with the windows slightly open for two to three minutes.

Temperature Control

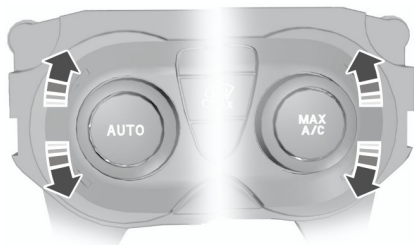

E133115

You can set the temperature between 60°F (15.5°C) and 85°F (29.5°C). In position LO, the system switches to permanent cooling. In position HI, the system switches to permanent heating.

Note: If you select either position LO or HI, the system does not regulate a stable temperature.

Mono Mode

In this mode, the temperature settings for both the driver side and passenger side are linked. If you adjust the setting using the rotary control on the driver side, the system adjusts the temperature to the same setting on the passenger side.

Switching Mono Mode Off

Select a temperature for the passenger side using the rotary control on the passenger side. Mono mode automatically switches off. The temperature on the driver side remains unchanged. You can now adjust the driver side and passenger side temperatures independently. The temperature settings for each side are shown in the display.

Switching Mono Mode Back On

Press and hold the **AUTO** button. The passenger side temperature is adjusted to the driver side temperature setting.

HINTS ON CONTROLLING THE INTERIOR CLIMATE

General Hints

Note: Prolonged use of recirculated air may cause the windows to fog up.

Note: A small amount of air may be felt from the footwell air vents regardless of the air distribution setting.

Note: To reduce humidity build-up inside your vehicle, do not drive with the system switched off or with recirculated air always switched on.

Note: Do not place objects under the front seats as this may interfere with the airflow to the rear seats.

Note: Keep the air intakes in front of the windshield free from obstruction (such as snow or leaves) to allow the climate control system to function effectively.

Climate Control

Note: To reduce fogging of the windshield during humid weather, adjust the air distribution control to the windshield air vents position. Increase the temperature and fan speed and press the A/C button to improve clearing, if required.

Heating the Interior Quickly

- Adjust the fan speed to the highest speed setting.
- Adjust the temperature control to the highest setting.
- Adjust the air distribution control to the footwell air vents position.

Recommended Settings for Heating

- Adjust the fan speed to the second speed setting.
- Adjust the temperature control to the midway point of the hot settings.
- Adjust the air distribution control to the footwell and windshield air vents position.

Cooling the Interior Quickly

- Adjust the fan speed to the highest speed setting.
- Adjust the temperature control to the **MAX A/C** position.
- Adjust the air distribution control to the instrument panel air vents position.

Recommended Settings for Cooling

- Adjust the fan speed to the second speed setting.
- Adjust the temperature control to the midway point of the cold settings.
- Adjust the air distribution control to the instrument panel air vents position.

Vehicle Stationary for Extended Periods During Extreme High Ambient Temperatures

- Apply the parking brake.
- Move the transmission selector lever to position **P** or neutral.
- Adjust the temperature control to the **MAX A/C** position.
- Adjust the fan speed to the lowest speed setting.

Side Window Defogging in Cold Weather

- Adjust the air distribution control to the instrument panel and windshield air vents positions.
- Press the **A/C** button.
- Adjust the temperature control to the desired setting.
- Adjust the fan speed to the highest setting.
- Direct the instrument panel side air vents toward the side windows.
- Close the instrument panel vents.

Maximum Cooling Performance in Instrument Panel or Instrument Panel and Footwell Positions

- Adjust the temperature control to the lowest setting.
- Press the **A/C** and recirculated air buttons.
- Adjust the fan speed to the highest setting initially and then adjust it to suit the desired comfort level.

Climate Control

REAR PASSENGER CLIMATE CONTROLS

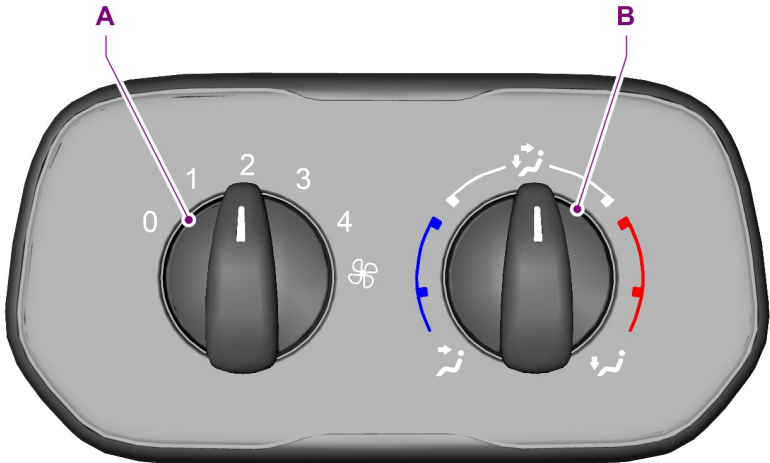

E163443

- A **Fan speed control:** Controls the volume of air circulated in your vehicle. Adjust to select the desired fan speed or switch off.
- B **Temperature and air distribution control:** Controls the temperature of the air circulated in your vehicle. Adjust to select the desired temperature and distribution.

Note: Switch the air conditioning on to cool the air through the rear air vents.

HEATED WINDOWS AND MIRRORS

Note: Make sure the engine is running before operating the heated windows.

Climate Control

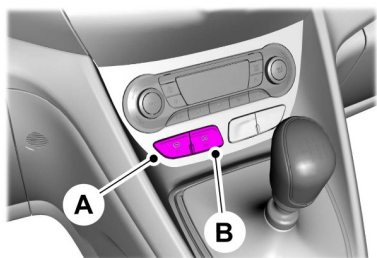

E170373

- A Heated windshield
- B Heated rear window or Heated exterior mirrors

Heated Windshield



Press the button to clear the heated windshield of thin ice and fog. Press the button again to switch it off. It will turn off automatically after a short period of time.

Heated Rear Window



Press the button to clear the heated rear window of thin ice and fog. Press the button again to switch it off. It will turn off automatically after a short period of time.

Note: Do not use razor blades or other sharp objects to clean the inside of the heated rear window. Do not use razor blades or other sharp objects to remove decals from the inside of the heated rear window. The vehicle warranty does not cover damage caused to the heated rear window grid lines.

Heated Exterior Mirrors (If Equipped)



Press the button to clear the heated exterior mirrors of thin ice and fog. They will turn off automatically after a short period of time.

Note: On vehicles without a heated exterior mirror switch, they will turn on automatically when you switch the heated rear window on.

Note: On vehicles without a heated rear window, the heated rear window button will turn on the heated mirrors.

Note: Do not remove ice from the mirror glass with a scraper. Do not adjust a frozen in place mirror glass. This may cause damage to the mirror glass or the heated exterior mirror assembly.

Note: Cleaning your windows and mirrors. See **Vehicle Care** (page 182).

AUXILIARY HEATER

Fuel Operated Parking Heater

WARNING



Do not operate the fuel operated parking heater at fuel filling stations or near sources of combustible vapors, dust or in enclosed spaces. This could result in serious personal injury or death.

The system warms the engine and your vehicle's interior; it uses fuel from the vehicle's fuel tank. The system will only operate while your vehicle is stationary with the engine switched off.

Climate Control

Used correctly, the system will:

- preheat the engine and your vehicle's interior
- keep the windows clear of ice in the event of frost and prevent condensation
- avoid cold starts to assist the engine to reach operating temperature sooner.

Following a heating cycle, if you do not start your vehicle's engine the system will not turn on the next programmed heating cycle.

Following a heating cycle and to prevent your vehicle's battery from losing charge, we recommend that you drive your vehicle for at least the same period of time as the heating cycle.

We recommend you switch the system on for approximately 10 minutes every month to prevent the water pump or heater motor seizing.

The system will only operate if there is a minimum of 7.5 liters (1.6 gallons) of fuel in your vehicle's fuel tank, and the ambient temperature is below 15°C (59°F). The system will not operate if the battery charge level is low.

Note: When the system is operating, exhaust fumes will come from under your vehicle. This is normal.

Note: On vehicles with manual climate control, heating your vehicle's interior will depend on the heater control settings. See **Climate Control** (page 73).

Programming the fuel operated parking heater

To programme the heating times:

1. Use the information display controls on the steering wheel to enter the main menu. See **Information Displays** (page 63).
2. Select **Park Heater**.

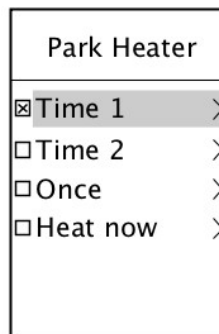

E136301

- The **Time 1** and **Time 2** functions allow you to programme up to two heating cycles for each day of the week. These times will remain stored and the system will warm up your vehicle at the programmed times.
- Selecting **Once** allows you to programme one heating cycle for one specific day.
- Selecting **Heat now** turns on the heater immediately.

Note: You must set the time and date on your vehicle's clock correctly. See **Clock** (page 67).

Note: The programmed time is the time at which you need the vehicle to be warm and ready to drive, not the time at which the heater switches on.

Note: The programmed times must be set at least 70 minutes in advance of the time you wish to set.

Climate Control

Programming the fuel operated parking heater functions Time 1 and Time 2

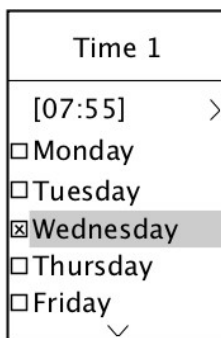

E74468

1. Use the information display controls on the steering wheel to enter the main menu. See **Information Displays** (page 63).
2. Select **Park Heater**.
3. Select **Time 1**.
4. Highlight the day on which the heater should warm up the vehicle.
5. Press the **OK** button.
6. Continue in the same way to select all the days on which the system should warm up the vehicle.
7. To set the time at which the vehicle should be warmed up and ready to drive, highlight the time at the top of the menu and press the **OK** button. The hours start to flash.
8. Adjust the hours and minutes as necessary using the arrow buttons on the information display controls.

You can use **Time 2** to set a second cycle, for example; different times on different days or twice on the same day. The programming procedure is the same as for the **Time 1** programme timer.

Programming the fuel operated parking heater for a single cycle

1. Use the information display controls on the steering wheel to enter the main menu. See **Information Displays** (page 63).
2. Select **Park Heater**.
3. Select **Once** and press the right arrow button.
4. Press the **OK** button and set the required time and date.
5. Press **OK** to confirm the set time and date.

Switching the fuel operated parking heater programming off

1. Use the information display controls on the steering wheel to enter the main menu. See **Information Displays** (page 63).
2. Select **Park Heater**.
3. Select **Time 1** or **Time 2**.
4. Uncheck the active programmed sessions as required.

Switching the fuel operated parking heater on manually

1. Use the information display controls on the steering wheel to enter the main menu. See **Information Displays** (page 63).
2. Select **Park Heater**.
3. Select **Heat now** and press the **OK** button. An **X** appears in the box when the heater is turned on.
4. To turn off the heater, uncheck **Heat now**.

Climate Control

Fuel Operated Heater

The system turns on and off automatically depending on the outside air temperature and your vehicle's engine coolant temperature, unless you have switched it off.

To switch off the fuel operated heater:

1. Use the information display controls on the steering wheel to enter the main menu. See **Information Displays** (page 63).
2. Select **Aux. Heater** and press the **OK** button.

Note: *An X appears in the box when the system is switched on.*

Seats

SITTING IN THE CORRECT POSITION

WARNINGS

 Do not recline the seatback too far as this can cause the occupant to slide under the safety belt, resulting in serious injury in the event of a collision.

 Sitting improperly, out of position or with the seatback reclined too far, can result in serious injury or death in the event of a collision. Always sit upright against your seatback, with your feet on the floor.

 Do not place objects higher than the seatback to reduce the risk of serious injury in the event of a collision or during heavy braking.

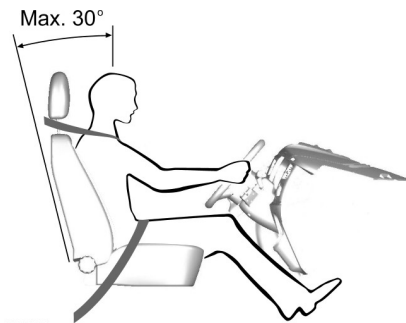

E68595

When you use them properly, the seat, head restraint, safety belt and air bags will provide optimum protection in the event of a collision.

We recommend that you follow these guidelines:

- Sit in an upright position with the base of your spine as far back as possible.
- Do not recline the seatback more than 30 degrees.

- Adjust the head restraint so that the top of it is level with the top of your head and as far forward as possible. Make sure that you remain comfortable.
- Keep sufficient distance between yourself and the steering wheel. We recommend a minimum of 10 inches (25 centimeters) between your breastbone and the air bag cover.
- Hold the steering wheel with your arms slightly bent.
- Bend your legs slightly so that you can press the pedals fully.
- Position the shoulder strap of the safety belt over the center of your shoulder and position the lap strap tightly across your hips.

Make sure that your driving position is comfortable and that you can maintain full control of your vehicle.

HEAD RESTRAINTS

WARNING

 Fully adjust the head restraint before you sit in or operate your vehicle. This will help minimize the risk of neck injury in the event of a collision. Do not adjust the head restraint when your vehicle is moving.

Adjusting the Head Restraints

Adjust the head restraint so that the top of it is level with the top of your head.

Seats

Removing the Head Restraints

Front Head Restraint

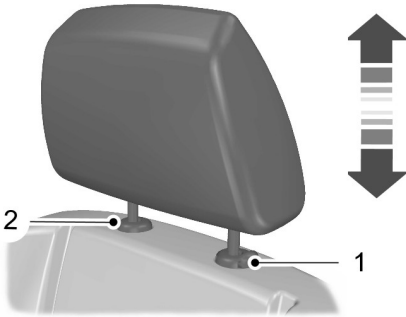

E140447

1. Press and hold the locking button.
2. Using a suitable implement release the retaining clip.

Rear Outer Head Restraint

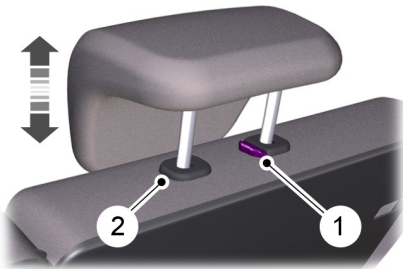

E140448

1. Press and hold the locking button.
2. Using a suitable implement release the retaining clip.

Rear Center Head Restraint

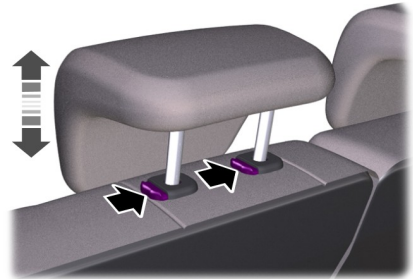



E135401

Press the locking buttons and remove the head restraint.

MANUAL SEATS

WARNINGS

 Do not adjust the driver seat or seatback when your vehicle is moving. Failure to follow this warning could result in serious personal injury or death.

 Do not place cargo or any objects behind the seatback before returning it to the original position. Pull on the seatback to make sure that it has fully latched after returning the seatback to its original position. An unlatched seat may become dangerous if you stop suddenly or have a crash.

Moving the Seat Backward and Forward

WARNING

 Rock the seat backward and forward after releasing the lever to make sure that it is fully engaged in its catch. An unlatched seat can be dangerous in a crash and could result in serious personal injury or death.

Seats



E130249

Adjusting the Lumbar Support

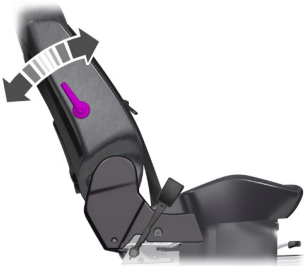

E142199

Adjusting the Height of the Driver Seat

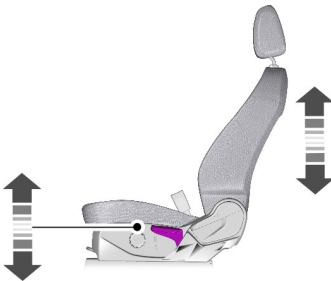

E70730

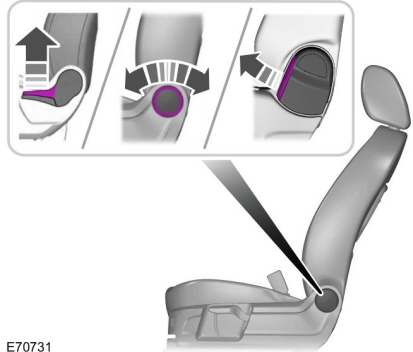

Recline Adjustment



E70731

Single Passenger Seat

WARNINGS

-  When folding the seatback down, take care not to get your fingers caught between the seatback and seat frame. Failure to follow this warning could result in serious personal injury.
-  Do not sit behind a seat that you fold forward. This can increase the risk of serious personal injury in a crash.

Seats

Folding the Seatback



E167549

1. Lift the lever.
2. Fold the seatback forward.

Dual Passenger Seat

WARNING



When folding the seatback down, take care not to get your fingers caught between the seatback and seat frame. Failure to follow this warning could result in serious personal injury.

Note: When loading long objects in to your vehicle, for example pipes, timber or furniture be careful not to damage the interior trim.

Folding the Center Seatback Down



E168479

1. Pull the strap on the side of the seatback.
2. Fold the seatback down.

Seats

Folding the Center Seat Cushion Up



E168478

1. Pull the strap on the side of the seatback.
2. Fold the seatback and seat cushion forward to the lower position.

Note: *The seat cushion will fold automatically with the seat back.*

Folding the Outer Seat Cushion Up

WARNING



Make sure that you fold the seat cushion down before you drive away.

Folding the Outer Seat Down



E167550



E168476

1. Pull the release lever.
2. Fold the seat cushion up until it locks into place.

Seats

Folding the Outer Seat Cushion Down



E168477

1. Pull the release lever.
2. Fold the seat cushion down until it locks into place.

Note: Fully lower the head restraint when folding the seats. See **Head Restraints** (page 84).

Vehicles With Five Seats

Folding the Seat Forward





E167551

1. Pull the strap on the side of the seatback.
2. Fold the seatback forward.

REAR SEATS

WARNINGS

 Do not use the bench seats as a bed when your vehicle is moving. Failure to follow this warning could result in serious personal injury or death.

 When folding the seatback down, take care not to get your fingers caught between the seatback and seat frame. Failure to follow this warning could result in serious personal injury.

 Do not place objects on a folded seat. Hard objects may become projectiles in a crash or sudden stop, which may increase the risk of serious personal injury.

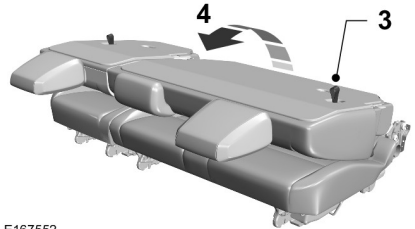

E167552

3. Pull the strap on the rear of the seatback.
4. Raise the seat.

Seats

Removing the Seats

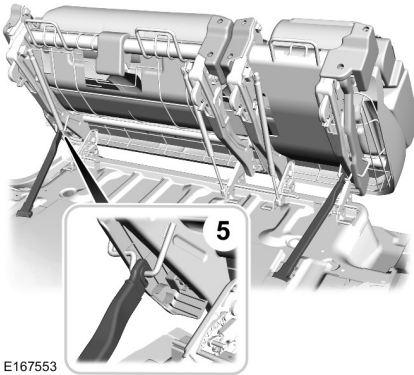

E167553

5. Lift the support rod and connect to the seat frame. This prevents the seat frame from falling backward.

Note: *Rear row occupants can sit next to a seat in the same row that has the seatback in the folded position, but not when the seat is in the tilted position.*

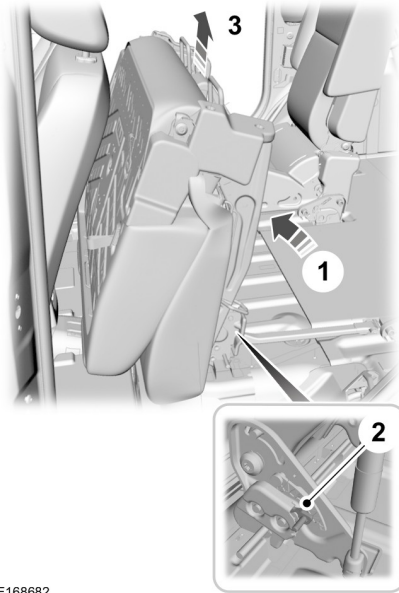

E168682

1. Raise the seat.
2. Rotate the locking lever.
3. Remove the seat.

Seats

Vehicles With Seven Seats

Second Row Seats

Folding the Seat Flat

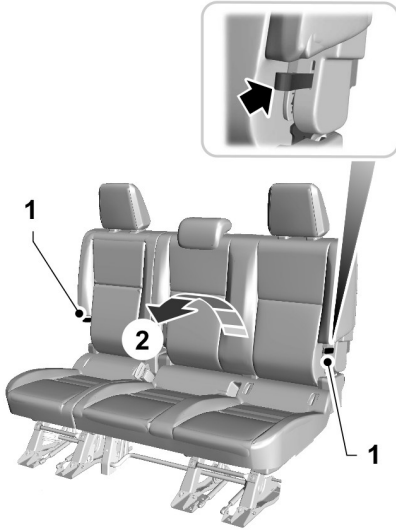

E167554

1. Pull the strap on the side of the seatback.
2. Fold the seatback forward.

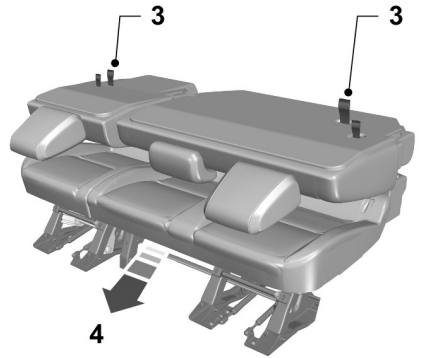

E167555

3. Pull the large strap on the rear of the seatback.
4. Move the seat forward to the lowered position.

Note: A distinct click will be heard when the seat is locked in the lowered position.

Note: Rear row occupants can sit next to a seat in the same row that has the seatback in the folded position, but not when the seat is in the tilted position.

Seats

Unfolding the Seat

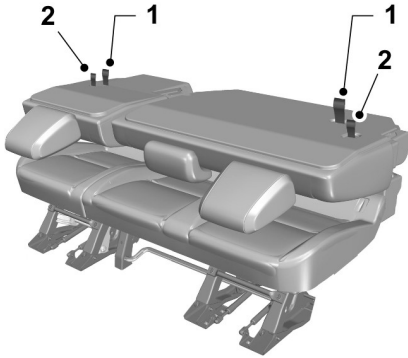

E169637

1. Pull the large strap on the rear of the seatback, lift the seat and push down to lock into position.
2. Pull the short strap on the rear of the seatback and unfold the seatback to the upright position.

Third Row Seats

Moving the Seat Backward and Forward

WARNING



Rock the seat backward and forward after releasing the lever to make sure that it is locked into position. A seat that it is not locked into position can be dangerous in a crash and could cause serious personal injury or death.

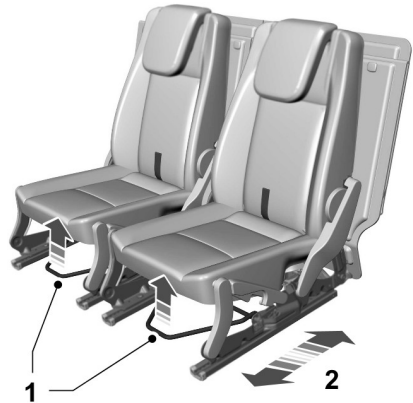

E167640

Folding the Seat Flat

1. Move the seat fully backward.



E167642

2. Pull the strap on the rear of the seat cushion.
3. Fold the seat cushion forward.

Seats

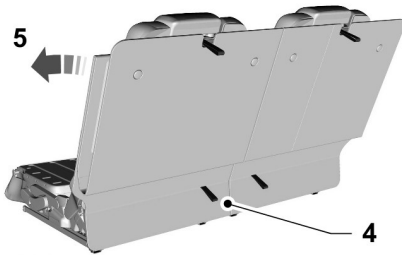

E167643

4. Pull the strap on the rear of the seatback.
5. Fold the seatback forward.

Unfolding the Seat

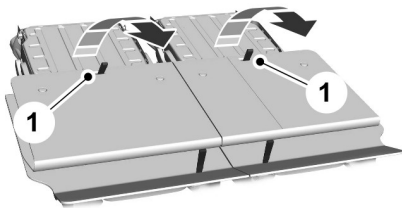

E167644

1. Pull the strap on the rear of the seatback.
2. Unfold the seatback to the upright position.
3. Unfold the seat cushion backward and lock into position.

Creating a Level Load Floor



E167645

The carpeted cover is held in position by magnets. Fold the carpeted cover forward to cover up the folded seats.

HEATED SEATS

WARNING



People who are unable to feel pain to their skin because of advanced age, chronic illness, diabetes, spinal cord injury, medication, alcohol use, exhaustion or other physical conditions, must exercise care when using the heated seat. The heated seat may cause burns even at low temperatures, especially if used for long periods of time. Do not place anything on the seat that insulates against heat, such as a blanket or cushion. This may cause the heated seat to overheat. Do not puncture the seat with pins, needles or other pointed objects. This may damage the heating element which may cause the heated seat to overheat. An overheated seat may cause serious personal injury.

Seats

Do not do the following:

- Place heavy objects on the seat.
- Operate the heated seat if water or any other liquid is spilled on the seat. Allow the seat to dry thoroughly.
- Operate the heated seats unless the engine is running. Doing so can cause the battery to lose charge.



E168588

Adjust the control to the desired heat setting.

REAR SEAT ARMREST





E165004

Fold the armrest down to use the armrest and cup holder.

Auxiliary Power Points

12 Volt DC Power Point

WARNINGS

-  Do not use the power point for operating a cigar lighter element, this can result in fire or serious injury.
-  Do not insert objects other than an accessory plug into the power point, this can result in fire or serious injury.

Run the engine for full capacity use of the power point.

To prevent the battery from running out of charge:

- Do not use the power point longer than necessary when the engine is not running.
- Do not leave devices plugged in overnight or when your vehicle is parked for extended periods.

Note: When you switch the ignition on you can use the power point to power 12 volt appliances with a maximum current rating of 20 amps.

Note: Do not hang any type of accessory or accessory bracket from an accessory plug.

Note: Do not use the power point over the vehicle capacity of 12 volt DC 180 watt or a fuse may blow.

Note: Incorrect use of the power points can cause damage not covered by the vehicle warranty.

Note: Always keep the power point caps closed when not in use.

Location

Power points may be found:

- on the center console
- on the rear of the center console
- in the luggage compartment.

CIGAR LIGHTER

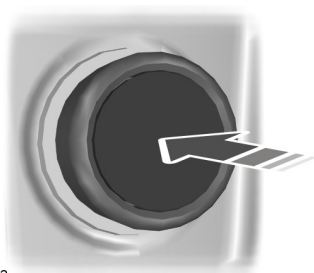

E103382

Press the element in to use the cigar lighter. It will pop out automatically.

Note: Do not hold the cigar lighter element pressed in.

Storage Compartments

CUP HOLDERS

WARNINGS

- ⚠ Do not place hot drinks in the cup holders when your vehicle is moving.
- ⚠ Make sure that cups placed in the holders do not obstruct your vision while driving.

CENTER CONSOLE

WARNING

- ⚠ Use only soft cups in the cupholder. Hard objects can injure you in a collision.

Your vehicle may be equipped with a variety of features.

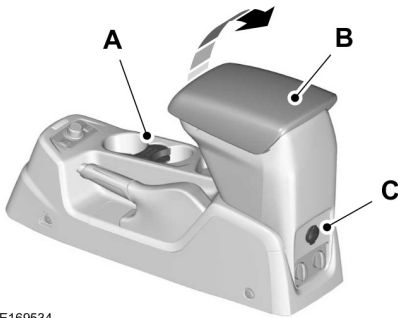

E169534

- A Cupholder
- B Storage compartment with auxiliary input jack and USB port
- C Auxiliary power point

OVERHEAD CONSOLE

WARNING

- ⚠ Do not place heavy objects in the storage compartment. Heavy objects may become projectiles in a crash or sudden stop, which may increase the risk of serious injury.

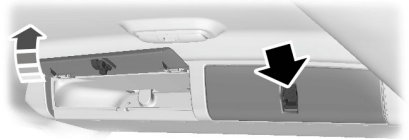

E163447

FOLDING TRAY

WARNING

- ⚠ Do not use the trays when your vehicle is moving. Make sure that you secure the trays in the lowered position before setting off.

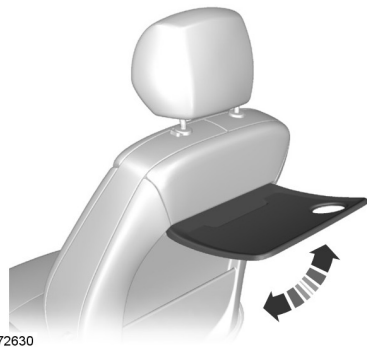



E72630

Starting and Stopping the Engine

GENERAL INFORMATION

WARNINGS

 Extended idling at high engine speeds can produce very high temperatures in the engine and exhaust system, creating the risk of fire or other damage.

 Do not park, idle or drive your vehicle on dry grass or other dry ground cover. The emission system heats up the engine compartment and exhaust system, creating the risk of fire.

 Do not start the engine in a closed garage or in other enclosed areas. Exhaust fumes can be toxic. Always open the garage door before you start the engine.

 If you smell exhaust fumes inside your vehicle, have your vehicle checked by an authorized dealer immediately. Do not drive your vehicle if you smell exhaust fumes.

If you disconnect the battery, your vehicle may exhibit some unusual driving characteristics for approximately 5 miles (8 kilometers) after you reconnect it. This is because the engine management system must realign itself with the engine. You can disregard any unusual driving characteristics during this period.

The powertrain control system meets all Canadian interference-causing equipment standard requirements regulating the impulse electrical field or radio noise.

When you start the engine, avoid pressing the accelerator pedal before and during operation. Only use the accelerator pedal when you have difficulty starting the engine.

IGNITION SWITCH



E72128

0 (off) - The ignition is off.

Note: When you switch the ignition off and leave your vehicle, do not leave your key in the ignition. This could cause your vehicle battery to lose charge.

I (accessory) - Allows the electrical accessories such as the radio to operate while the engine is not running.

Note: Do not leave the ignition key in position **I** or **II** (without the engine running) for too long to avoid vehicle battery losing charge.

II (on) - All electrical circuits operational. Warning lamps and indicators are illuminated.

III (start) - cranks the engine. Release the key as soon as the engine starts.

STEERING WHEEL LOCK

WARNING

 Always check that the steering is unlocked before attempting to move your vehicle.

To lock the steering wheel:

1. Remove the key from the ignition switch.
2. Rotate the steering wheel slightly to engage the lock.

Starting and Stopping the Engine

To unlock the steering wheel:

1. Insert the key in the ignition switch.
2. Turn the key to position **I**.

Note: You may need to rotate the steering wheel slightly to assist unlocking if there is a steering wheel load applied.

STARTING A GASOLINE ENGINE - VEHICLES WITH: MANUAL TRANSMISSION

Cold or Hot Engine

1. Fully depress the clutch pedal.
2. Start the engine.

If the engine does not start within 10 seconds, wait for a short period and try again.

If the engine does not start after three attempts, wait 10 seconds and follow the flooded engine procedure.

If you have difficulty starting the engine when the temperature is below -13°F (-25°C), press the accelerator pedal to the mid-way point of its travel and try again.

Note: Do not touch the accelerator pedal.

Note: Releasing the clutch pedal while the engine is starting will stop the engine cranking and return to ignition on.

Note: You can only operate the starter for a limited period of time, for example 10 seconds. The number of start attempts is limited to approximately six. If you exceed this limit, the system will not allow you to try again until a period of time has elapsed, for example 30 minutes.

Flooded Engine

1. Fully depress the clutch pedal.
2. Fully depress the accelerator pedal and hold it there.

3. Start the engine.

If the engine does not start, repeat the cold or hot engine procedure.

Engine Idle Speed after Starting

The speed at which the engine idles immediately after starting is optimized to minimize vehicle emissions and maximize cabin comfort and fuel economy.

The idle speed will vary depending on certain factors. These include vehicle component and ambient temperatures as well as electrical and climate system demands.

Failure to Start

If the engine does not crank when the clutch pedal has been fully depressed and the ignition key is turned to position **III**.

1. Fully depress the clutch and brake pedals.
2. Turn the key to position **III** until the engine has started.

STARTING A GASOLINE ENGINE - VEHICLES WITH: AUTOMATIC TRANSMISSION

Cold or Hot Engine

Note: Do not touch the accelerator pedal.

1. Move the transmission selector lever to position **P** or **N**.
2. Start the engine.

If the engine does not start within 10 seconds, wait for a short period and try again.

If the engine does not start after three attempts, wait 10 seconds and follow the flooded engine procedure.

Starting and Stopping the Engine

If you have difficulty starting the engine when the temperature is below -13°F (-25°C), press the accelerator pedal to the mid-way point of its travel and try again.

Note: You can only operate the starter for a limited period of time, for example 10 seconds. The number of start attempts is limited to approximately six. If you exceed this limit, the system will not allow you to try again until a period of time has elapsed, for example 30 minutes.

Flooded Engine

1. Move the transmission selector lever to position **P** or **N**.
2. Fully depress the accelerator pedal and hold it there.
3. Start the engine.

If the engine does not start, repeat the cold or hot engine procedure.

Engine Idle Speed after Starting

The speed at which the engine idles immediately after starting is optimized to minimize vehicle emissions and maximize cabin comfort and fuel economy.

The idle speed will vary depending on certain factors. These include vehicle component and ambient temperatures as well as electrical and climate system demands.

STARTING A DIESEL ENGINE

Cold or Hot Engine



1. Switch the ignition on and wait until the glow plug indicator goes off.
2. Fully depress the clutch pedal.
3. Start the engine.

Note: Do not touch the accelerator pedal.

Note: Releasing the clutch pedal while the engine is starting will stop the engine cranking and return to ignition on.

Note: When the temperature is below 5°F (-15°C), you may need to crank the engine for up to 10 seconds.

Note: You can only operate the starter for a limited period of time.

Note: After a limited number of attempts to start your engine, the system will not allow you to try again until a period of time has elapsed, for example 30 minutes.

Failure to Start

If the engine does not crank when the clutch pedal has been fully depressed and the ignition key is turned to position **III**.

1. Fully depress the clutch and brake pedals.
2. Turn the key to position **III** until the engine has started.

DIESEL PARTICULATE FILTER

The filter forms part of the emissions reduction system on your vehicle. It filters harmful diesel particulates (soot) from the exhaust gas.

Regeneration

WARNINGS



Do not park or idle your vehicle over dry leaves, dry grass or other combustible materials. The regeneration process creates very high exhaust gas temperatures and the exhaust will radiate a considerable amount of heat during and after regeneration and after you have switched the engine off. This is a potential fire hazard.



Avoid running out of fuel.

Starting and Stopping the Engine

Note: During regeneration at low speed or engine idle, you may smell a hot metallic odor and could notice a clicking metallic sound. This is due to the high temperatures reached during regeneration and is normal.

Note: After you have switched your engine off the fans may continue to run for a short period of time.

A normal filter requires periodic replacement. The diesel particulate filter on your vehicle requires periodic regeneration to maintain its correct function. Your vehicle will carry out this process automatically.

If your journeys meet one of the following conditions:

- You drive only short distances.
- You frequently switch the ignition on and off.
- Your journeys contain a high level of acceleration and deceleration.

You must carry out occasional trips with the following conditions to assist the regeneration process:

- Drive your vehicle in more favorable conditions, which you will find at higher vehicle speeds in normal driving, on a main road or freeway for a minimum of 20 minutes. This drive may include short stops that will not affect the regeneration process.
- Avoid prolonged idling and always observe speed limits and road conditions.
- Do not switch the ignition off.
- Select a suitable gear to ideally maintain engine speed between 1500 and 3000 RPM.

SWITCHING OFF THE ENGINE

Vehicles With a Turbocharger

WARNING

 Do not switch the engine off when it is running at high speed. If you do, the turbocharger will continue running after the engine oil pressure has dropped to zero. This will lead to premature turbocharger bearing wear.

Release the accelerator pedal. Wait until the engine has reached idle speed and then switch it off.

ENGINE BLOCK HEATER

WARNINGS

 Failure to follow engine block heater instructions could result in property damage or serious personal injury.

 Do not use your heater with ungrounded electrical systems or two-pronged adapters. There is a risk of electrical shock.

Note: The heater is most effective when outdoor temperatures are below 0°F (-18°C).

The heater acts as a starting aid by warming the engine coolant. This allows the climate control system to respond quickly. The equipment includes a heater element (installed in the engine block) and a wire harness. You can connect the system to a grounded 220 volt AC electrical source.

Starting and Stopping the Engine

We recommend that you do the following for a safe and correct operation:

- Use an extension cord suitable for use outdoors and in cold temperatures. It should be clearly marked that it is suitable for use with outdoor appliances. Do not use an indoor extension cord outdoors. This could result in an electric shock or become a fire hazard.
- Use as short an extension cord as possible.
- Do not use multiple extension cords.
- Make sure that when in operation, the extension cord plug and heater cord plug connections are free and clear of water. This could cause an electric shock or fire.
- Make sure your vehicle is parked in a clean area, clear of combustibles.
- Make sure the heater, heater cord and extension cord are firmly connected.
- Check for heat anywhere in the electrical hookup once the system has been operating for approximately 30 minutes.
- Make sure the system is unplugged and properly stowed before driving your vehicle. Make sure the protective cover seals the prongs of the block heater cord plug when not in use.
- Make sure the heater system is checked for proper operation before winter.

The heater uses 0.4 to 1.0 kilowatt-hours of energy per hour of use. The system does not have a thermostat. It achieves maximum temperature after approximately three hours of operation. Using the heater longer than three hours does not improve system performance and unnecessarily uses electricity.

Using the Engine Block Heater

Make sure the receptacle terminals are clean and dry prior to use. Clean them with a dry cloth if necessary.

Unique Driving Characteristics

AUTO-START-STOP - BASE ECOLITE

ECO System

Note: For vehicles with Start-Stop the battery requirement is different. You must replace the vehicle battery with one of exactly the same specification.

The system comprises of Start-Stop and a speed limiter. Together they help reduce fuel consumption and CO2 emissions by shutting down the engine when your vehicle is idling, for example at traffic lights. The engine will restart when you press the clutch pedal and when required by a vehicle system, for example to recharge the battery. The system will also limit your vehicle speed to 70 mph (110 km/h). See **Speed Limiter** (page 129).

To obtain maximum benefit from the system, move the transmission selector lever to neutral and release the clutch pedal during any stop of longer than three seconds.

Using Start-Stop

WARNINGS



The engine may restart automatically if required by the system. It will only automatically restart when one of the pedals is pressed. If no pedal is pressed, the Start-Stop indicator will flash and a message will be shown in the display.



Switch the ignition off before opening the hood or carrying out any maintenance.



Always switch the ignition off before leaving your vehicle, as the system may have shut down the engine but the ignition will still be live.

WARNINGS



The system may not function if you leave extra loads connected with the ignition off.

Note: The system only operates when the engine is warm and the outside temperature is less than 104°F (40°C).

Note: If you stall the engine and then depress the clutch pedal within five seconds, the system will automatically restart the engine.

Note: The Start-Stop indicator will illuminate green when the engine shuts down. See **Warning Lamps and Indicators** (page 59).

Note: If the system detects a malfunction, it will switch off. The **OFF** lamp on the **ECO** switch will illuminate continuously. If this remains on after an ignition cycle, have your vehicle checked by an authorized dealer.

Note: When you switch the system off, the switch will illuminate.

Note: The system will be turned on in conjunction with the speed limiter. See **Speed Limiter** (page 129).

Switching the System Off and On



E145447

Unique Driving Characteristics

The system automatically turns on every time you switch the ignition on. To switch the system off, press the switch in the instrument panel. The system will only be turned off for the current ignition cycle. To turn it on, press the switch again. For item location: See **Instrument Panel Overview** (page 15).

To Stop the Engine

1. Stop your vehicle.
 2. Move the transmission selector lever to neutral.
 3. Release the clutch pedal.
 4. Release the accelerator pedal.
- The system may not shut down the engine under certain conditions, for example:

- Low battery charge.
- The outside temperature is too low or too high.
- The driver door has been opened.
- Low engine operating temperature.
- The heated windshield or heated rear window is switched on.
- During regeneration of the Diesel Particulate Filter.

To Restart the Engine

Depress the clutch pedal.

Note: *The transmission selector lever must be in neutral. If the transmission selector lever is not in neutral, the Start-Stop indicator will flash and a message will be shown in the display.*

The system may request an engine restart under certain conditions, for example:

- Low battery charge.
- The heated windshield or heated rear window is switched on.
- Your vehicle has started moving (for example, rolling downhill).

AUTO-START-STOP

Note: *For vehicles with start-stop the battery requirement is different. It must be replaced by one of exactly the same specification as the original.*

The system reduces fuel consumption and CO2 emissions by shutting down the engine when your vehicle is idling, for example at traffic lights. The engine will automatically restart when you press the clutch pedal or when required by a vehicle system, for example to recharge the battery.

To obtain maximum benefit from the system, move the transmission selector lever to neutral and release the clutch pedal during any stop of longer than three seconds.

Using Start-Stop

WARNINGS



The engine may restart automatically if required by the system.



Switch the ignition off before opening the hood or carrying out any maintenance.



Always switch the ignition off before leaving your vehicle, as the system may have shut down the engine but the ignition will still be live.

Note: *The system only operates when the engine is warm and the outside temperature is between 32°F (0°C) and 86°F (30°C).*

Note: *If you stall the engine, and then depress the clutch pedal within a short period of time, the system will automatically restart the engine.*

Note: *The start-stop indicator will illuminate green when the engine shuts down. See **Audible Warnings and Indicators** (page 62).*

Unique Driving Characteristics



Note: When the start-stop indicator flashes amber, move the transmission selector lever to neutral or depress the clutch pedal.

Note: If the system detects a malfunction, it will switch off. Have your vehicle checked by an authorized dealer.

Note: When you switch the system off, the switch will illuminate.

Note: The system automatically turns on every time you switch the ignition on. To switch the system off, press the switch in the instrument panel. The system will only be switched off for the current ignition cycle. To turn it on, press the switch again. For item location: See **Instrument Panel Overview** (page 15).

To Stop the Engine

1. Stop your vehicle.
2. Move the transmission selector lever to neutral.
3. Release the clutch pedal.
4. Release the accelerator pedal.

The system may not shut down the engine under certain conditions, for example:

- To maintain the interior climate.
- Low battery voltage.
- The outside temperature is too low or too high.
- The driver's door has been opened.
- Low engine operating temperature.
- Low brake system vacuum.
- If a road speed of 3 mph (5 km/h) has not been exceeded.
- The driver's safety belt has not been fastened.

To Re-Start the Engine

Note: The transmission selector lever must be in neutral.

Depress the clutch pedal.

The system may automatically restart the engine under certain conditions, for example:

- Low battery voltage.
- To maintain the interior climate.

Fuel and Refueling

SAFETY PRECAUTIONS

WARNINGS



Do not overfill the fuel tank. The pressure in an overfilled tank may cause leakage and lead to fuel spray and fire.



The fuel system may be under pressure. If you hear a hissing sound near the fuel filler door (Easy Fuel capless fuel system), do not refuel until the sound stops. Otherwise, fuel may spray out, which could cause serious personal injury.



Automotive fuels can cause serious injury or death if misused or mishandled.



The flow of fuel through a fuel pump nozzle can produce static electricity, which can cause a fire if fuel is pumped into an ungrounded fuel container.



Fuel ethanol and gasoline may contain benzene, which is a cancer-causing agent.



When refueling always shut the engine off and never allow sparks or open flames near the filler neck. Never smoke or use a cell phone while refueling. Fuel vapor is extremely hazardous under certain conditions. Avoid inhaling excess fumes.

Observe the following guidelines when handling automotive fuel:

- Extinguish all smoking materials and any open flames before refueling your vehicle.
- Always turn off the vehicle before refueling.
- Automotive fuels can be harmful or fatal if swallowed. Fuel such as gasoline is highly toxic and if swallowed can cause death or permanent injury. If fuel is swallowed, call a physician immediately, even if no symptoms are immediately apparent. The toxic effects of fuel may not be visible for hours.
- Avoid inhaling fuel vapors. Inhaling too much fuel vapor of any kind can lead to eye and respiratory tract irritation. In severe cases, excessive or prolonged breathing of fuel vapor can cause serious illness and permanent injury.
- Avoid getting fuel liquid in your eyes. If fuel is splashed in the eyes, remove contact lenses (if worn), flush with water for 15 minutes and seek medical attention. Failure to seek proper medical attention could lead to permanent injury.
- Fuels can also be harmful if absorbed through the skin. If fuel is splashed on the skin, clothing or both, promptly remove contaminated clothing and wash skin thoroughly with soap and water. Repeated or prolonged skin contact with fuel liquid or vapor causes skin irritation.
- Be particularly careful if you are taking "Antabuse" or other forms of disulfiram for the treatment of alcoholism. Breathing gasoline vapors, or skin contact could cause an adverse reaction. In sensitive individuals, serious personal injury or sickness may result. If fuel is splashed on the skin, promptly wash skin thoroughly with soap and water. Consult a physician immediately if you experience an adverse reaction.

Fuel and Refueling

FUEL QUALITY - GASOLINE

WARNINGS



Do not mix gasoline with oil, diesel or other liquids. This could cause a chemical reaction.



Do not use leaded gasoline or gasoline with additives containing other metallic compounds (e.g. manganese-based). They could damage the emission system.

Note: We recommend that you use only high quality fuel.

Note: We do not recommend the use of additional additives or other engine treatments for normal vehicle use.

Use minimum 95 octane unleaded gasoline that meets the specification defined by EN 228 or the equivalent national specification.

Your vehicle is suitable for use with ethanol blends up to 10% (E5 and E10).

Long-Term Storage

Most gasoline contains ethanol. We recommend that you fill the fuel tank with fuel that does not contain ethanol if you intend to store your vehicle for more than two months. Alternatively, we recommend that you seek advice from an authorized dealer.

FUEL QUALITY - DIESEL

WARNINGS



Do not mix diesel with oil, gasoline or other liquids. This could cause a chemical reaction.



Do not add kerosene, paraffin or gasoline to diesel. This could cause damage to the fuel system.

WARNINGS



Use diesel that meets the specification defined by EN 590 or the relevant national specification.

Note: We recommend that you use only high quality fuel.

Note: We do not recommend the use of additional additives or other engine treatments for normal vehicle use.

Note: We do not recommend the use of additional additives to prevent fuel waxing.

Long-Term Storage

Most diesel fuels contain biodiesel. We recommend that you fill the fuel tank with fuel that does not contain biodiesel if you intend to store your vehicle for more than two months. Alternatively, we recommend that you seek advice from your dealer.

RUNNING OUT OF FUEL

Avoid running out of fuel because this situation may have an adverse effect on powertrain components.

If you have run out of fuel:

- You may need to cycle the ignition from off to on several times after refueling to allow the fuel system to pump the fuel from the tank to the engine. On restarting, cranking time will take a few seconds longer than normal. With keyless ignition, just start the engine. Crank time will be longer than usual.
- Normally, adding 1 gallon (4.6 liters) of fuel is enough to restart the engine. If your vehicle is out of fuel and on a steep grade, more fuel may be required.

Fuel and Refueling

Refilling With a Portable Fuel Container

WARNINGS



Do not insert the nozzle of portable fuel containers or aftermarket funnels into the capless fuel system.

This could damage the fuel system and its seal, and may cause fuel to run onto the ground instead of filling the tank, which could result in serious personal injury.



Do not try to pry open or push open the capless fuel system with foreign objects. This could damage the fuel system and its seal and cause injury to you or others.

When filling your vehicle's fuel tank from a portable fuel container, use the funnel included with your vehicle.

Use the following guidelines to avoid electrostatic charge build-up when filling an ungrounded fuel container:

- Place approved fuel container on the ground.
- Do not fill a fuel container while it is in the vehicle (including the cargo area).
- Keep the fuel pump nozzle in contact with the fuel container while filling.
- Do not use a device that would hold the fuel pump handle in the fill position.



E142668

1. Locate the plastic funnel in the glove box.
2. Slowly insert the funnel into the capless fuel system.
3. Fill your vehicle with fuel from the portable fuel container.
4. When done, clean the funnel or properly dispose of it. Extra funnels can be purchased from your authorized dealer if you choose to dispose of the funnel.

CATALYTIC CONVERTER

WARNING



Do not park or idle your vehicle over dry leaves, dry grass or other combustible materials. The exhaust will radiate a considerable amount of heat during use, and after you have switched the engine off. This is a potential fire hazard.

Driving with a Catalytic Converter

WARNINGS



Avoid running out of fuel.



Do not crank the engine for long periods.



Do not run the engine when a spark plug lead is disconnected.



Do not push-start or tow-start your vehicle. Use booster cables. See **Jump-Starting the Vehicle** (page 144).





Do not switch the ignition off when driving.

Fuel and Refueling

REFUELING

WARNINGS

 Do not attempt to start the engine if you have filled the fuel tank with the incorrect fuel. This could damage the engine. Have your vehicle checked by an authorized dealer immediately.

 Do not use any kind of flames or heat near the fuel system. The fuel system is under pressure. There is a risk of injury if the fuel system is leaking.

 If you use a high pressure spray to wash your vehicle, only spray the fuel filler flap briefly from a distance not less than 8 inches (200 millimeters).

 We recommend that you wait at least 10 seconds before removing the fuel nozzle to allow any residual fuel to drain into the fuel tank.

 Stop refueling after the fuel nozzle stops the second time. Additional fuel will fill the expansion space in the fuel tank which could lead to fuel overflowing. Fuel spillage could be hazardous to other road users.

 Do not remove the fuel nozzle from its fully inserted position during the entire refueling process.

Note: Your vehicle does not have a fuel filler cap.

Note: It is not possible to fully open the sliding door when the fuel filler flap is open.

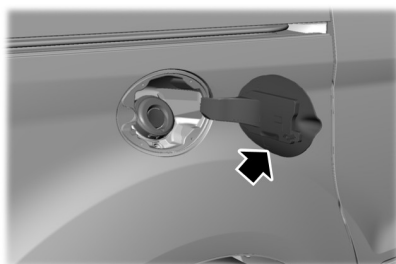

E164807

1. Pull the flap to open it. Open the flap fully until it engages.

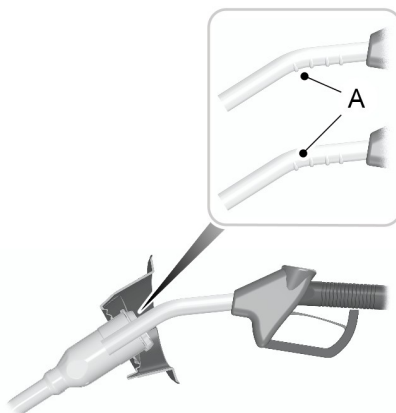

E139202

Note: When you insert the correct size fuel nozzle, a spring loaded inhibitor will open. This helps to avoid filling up with the incorrect fuel.

2. Insert the fuel nozzle up to and including the first notch on the fuel nozzle A. Keep it resting on the cover of the fuel pipe opening.

Fuel and Refueling

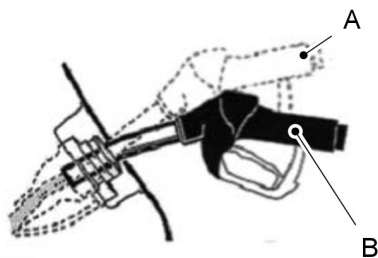

E139203

3. Hold the fuel nozzle in position B during refueling. Holding the fuel nozzle in position A can affect the flow of fuel and shut off the fuel nozzle before the fuel tank is full.

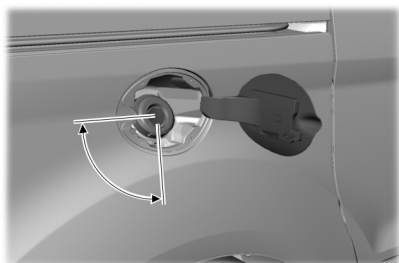

E164808

4. Operate the fuel nozzle within the area shown.

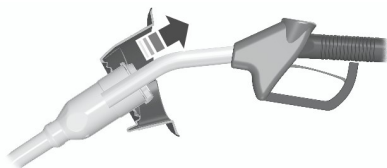

E119081

5. Slightly raise the fuel nozzle to remove it.

Filling a Fuel Container

Use the following guidelines to avoid electrostatic charge build-up when filling an ungrounded fuel container:

- Place approved fuel container on the ground.
- Do not fill a fuel container while it is in the vehicle (including the cargo area).
- Keep the fuel pump nozzle in contact with the fuel container while filling.
- Do not use a device that would hold the fuel pump handle in the fill position.

FUEL CONSUMPTION

Note: *The amount of usable fuel in the empty reserve varies and should not be relied upon to increase driving range. When refueling your vehicle after the fuel gauge indicates empty, you might not be able to refuel the full amount of the advertised capacity of the fuel tank due to the empty reserve still present in the tank.*

The CO₂ and fuel consumption figures are derived from laboratory tests according to Regulation (EC) 715/2007 and subsequent amendments are carried out by all vehicle manufacturers.

They are intended as a comparison between makes and models of vehicles. They are not intended to represent the real world fuel consumption you may get from your vehicle. Real world fuel consumption is governed by many factors including: driving style, high speed driving, stop-start driving, air conditioning usage, the accessories fitted, payload, towing, etc.

The advertised capacity is the indicated capacity and the empty reserve combined. Indicated capacity is the difference in the amount of fuel in a full tank and a tank when the fuel gauge indicates empty. Empty reserve is the amount of fuel in the tank after the fuel gauge indicates empty.

Fuel and Refueling

Filling the Tank

For consistent results when refueling:

- Switch the ignition off before refueling. An inaccurate reading results if you leave the engine running.
- Use the same fill rate (low-medium-high) each time the tank is filled.
- Allow no more than two automatic shut-offs when refueling.

Results are most accurate when the refueling method is consistent.

Calculating Fuel Economy

Do not measure fuel economy during the first 1000 miles (1600 km) of driving (this is your engine's break-in period). A more accurate measurement is obtained after 2000 - 3000 miles (3200 - 4800 km). Also, fuel expense, frequency of fill ups or fuel gauge readings are not accurate ways to measure fuel economy.

1. Fill the fuel tank completely and record the initial odometer reading.
2. Each time you fill the tank, record the amount of fuel added.
3. After at least three to five tank fill ups, fill the fuel tank and record the current odometer reading.
4. Subtract your initial odometer reading from the current odometer reading.
5. Calculate fuel economy by dividing miles traveled by gallons used (For Metric: Multiply liters used by 100, then divide by kilometers traveled).

Keep a record for at least one month and record the type of driving (city or freeway). This provides an accurate estimate of your vehicle's fuel economy under current driving conditions. Additionally, keeping records during summer and winter show how temperature impacts fuel economy. In general, lower temperatures mean lower fuel economy.

FUEL CONSUMPTION FIGURES - 1.0L ECOBOOST (74KW/100PS)

Fuel Consumption Figures

Variant	Urban	Extra-Urban	Combined	CO2 Emissions
	MPG (L/100 km)	MPG (L/100 km)	MPG (L/100 km)	g/km
All	44.1 (6.4)	55.4 (5.1)	50.4 (5.6)	129

Fuel and Refueling

FUEL CONSUMPTION FIGURES - 1.6LECOBOOST (110KW/150PS) - SIGMA

Fuel Consumption Figures

Variant	Urban	Extra-Urban	Combined	CO2 Emissions
	MPG (L/100 km)	MPG (L/100 km)	MPG (L/100 km)	g/km
Van vehicles with: Short Wheel Base	26.1 (10.8)	47.9 (5.9)	36.7 (7.7)	179
All except van vehicles with: Short Wheel Base	25.9 (10.9)	44.8 (6.3)	35.3 (8)	184

FUEL CONSUMPTION FIGURES - 1.6L DURATORQ-TDCI (55KW/75PS)/1.6L DURATORQ-TDCI (70KW/95PS) (TZ)

Fuel Consumption Figures

Vehicles without: Auto-Start-Stop

Variant	Urban	Extra-Urban	Combined	CO2 Emissions
	MPG (L/100 km)	MPG (L/100 km)	MPG (L/100 km)	g/km
All M1 vehicles	50.4 (5.6)	61.4 (4.6)	56.5 (5)	130
N1 vehicles with: Short Wheel Base	51.4 (5.5)	65.7 (4.3)	58.8 (4.8)	124
N1 vehicles with: Long Wheel Base	51.4 (5.5)	62.8 (4.5)	57.6 (4.9)	128

Fuel and Refueling

Vehicles with: Auto-Start-Stop

Variant	Urban	Extra-Urban	Combined	CO2 Emissions
	MPG (L/100 km)	MPG (L/100 km)	MPG (L/100 km)	g/km
M1 vehicles with: Short Wheel Base	61.4 (4.6)	76.3 (3.7)	70.6 (4)	121
M1 vehicles with: Long Wheel Base	61.4 (4.6)	76.3 (3.7)	68.9 (4.1)	120
Van N1 vehicles with: Short Wheel Base	58.8 (4.8)	67.3 (4.2)	64.2 (4.4)	115
All N1 vehicles except van N1 vehicles with: Short Wheel Base	56.5 (5)	65.7 (4.3)	61.4 (4.6)	119

FUEL CONSUMPTION FIGURES - 1.6L DURATORQ-TDCI (70KW/95PS) (TZ), BASE ECOLITE

Fuel Consumption Figures

Vehicles without: Speed Limiter

Variant	Urban	Extra-Urban	Combined	CO2 Emissions
	MPG (L/100 km)	MPG (L/100 km)	MPG (L/100 km)	g/km
Kombi vehicles with: Short Wheel Base	57.6 (4.9)	64.2 (4.4)	61.4 (4.6)	119
Van vehicles with: Short Wheel Base	61.4 (4.6)	74.4 (3.9)	67.3 (4.2)	109
Vehicles with: Long Wheel Base	61.4 (4.6)	68.9 (4.1)	65.7 (4.3)	112

Fuel and Refueling

Vehicles with: Speed Limiter

Variant	Urban	Extra-Urban	Combined	CO2 Emissions
	MPG (L/100 km)	MPG (L/100 km)	MPG (L/100 km)	g/km
Kombi vehicles with: Short Wheel Base	57.6 (4.9)	68.9 (4.1)	64.2 (4.4)	115
Van vehicles with: Short Wheel Base	62.8 (4.5)	76.3 (3.7)	70.6 (4)	105
Vehicles with: Long Wheel Base	60.1 (4.7)	74.3 (3.8)	68.9 (4.1)	108

FUEL CONSUMPTION FIGURES - 1.6L DURATORQ-TDCI (85KW/115PS)

Fuel Consumption Figures

Variant	Urban	Extra-Urban	Combined	CO2 Emissions
	MPG (L/100 km)	MPG (L/100 km)	MPG (L/100 km)	g/km
All M1 vehicles	50.4 (5.6)	61.4 (4.6)	58.8 (4.8)	130
Van N1 vehicles with: Short Wheel Base	51.4 (5.5)	65.7 (4.3)	60.1 (4.7)	124
All N1 vehicles except van N1 vehicles with: Short Wheel Base	49.5 (5.7)	64.2 (4.4)	57.6 (4.9)	128

Transmission

MANUAL TRANSMISSION - VEHICLES WITH: 6-SPEED MANUAL TRANSMISSION

Selecting Reverse Gear

Do not engage reverse gear when your vehicle is moving. This can cause damage to the transmission.

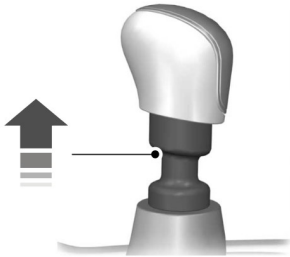

E99067

Raise the collar when you select reverse gear.

MANUAL TRANSMISSION - VEHICLES WITH: 5-SPEED MANUAL TRANSMISSION

Selecting Reverse Gear

Do not engage reverse gear when your vehicle is moving. This can cause damage to the transmission.

AUTOMATIC TRANSMISSION

WARNING

 Always set the parking brake fully and make sure you move the transmission selector lever to park. Switch the ignition off and remove the key whenever you leave your vehicle.

Selector Lever Positions



E133124

- P Park
- R Reverse
- N Neutral
- D Drive
- S Sport mode and manual shifting
- + Manual shift up
- Manual shift down

WARNING

 Apply the brakes before moving the transmission selector lever and keep them applied until you are ready to move off.

Press the button on the transmission selector lever to change to each position. The transmission selector lever position will be shown in the display.

P (Park)

WARNINGS

 Move the transmission selector lever to park only when your vehicle is stationary.

Transmission

WARNINGS



Apply the parking brake and move the transmission selector lever to park before leaving your vehicle.

Make sure that the transmission selector lever is latched in position.

In this position, power is not transmitted to the drive wheels and the transmission is locked. You can start the engine with the transmission selector lever in this position.

Note: An audible warning will sound if you open the driver's door and you have not moved the transmission selector lever to park.

R (Reverse)

WARNINGS



Move the transmission selector lever to reverse only when your vehicle is stationary and the engine is at idle speed.



Always come to a complete stop before shifting the transmission selector lever out of reverse.

Move the transmission selector lever to reverse to allow your vehicle to move backward.

N (Neutral)

In this position, power is not transmitted to the drive wheels but the transmission is not locked. You can start the engine with the transmission selector lever in this position.

D (Drive)

Note: A shift will occur only when your vehicle speed and the engine speed are appropriate.

Note: You may temporarily override the current gear selected using the + or - buttons.

Select drive to shift automatically through the forward gears.

The transmission will select the appropriate gear for optimum performance based on ambient temperature, road gradient, vehicle load and your input.

Sport Mode and Manual Shifting

Sport Mode

Note: In sport mode the transmission operates as normal but gears are selected more quickly and at higher engine speeds.

Note: In sport mode **S** will be shown in the display.

Switch on sport mode by moving the transmission selector lever to Sport. Sport mode will remain on until either you shift manually up or down the gears using the + or - buttons or move the transmission selector lever to drive.

Manual Shifting

WARNINGS



Do not hold the buttons permanently in + or -.



The transmission will automatically downshift when the engine speed is too low.

Press the - button to shift down and press the + button to shift up.

Gears may be skipped by pressing the buttons repeatedly at short intervals.

Manual mode also provides a kickdown function. See Kickdown.

Transmission

Hints on Driving with an Automatic Transmission

WARNING



Do not idle the engine for long periods of time in drive with the brakes applied.

Moving Off

1. Release the parking brake.
2. Release the brake pedal and press the accelerator pedal.

Stopping

1. Release the accelerator pedal and press the brake pedal.
2. Apply the parking brake.
3. Move the transmission selector lever to neutral or park.

Kickdown

Press the accelerator pedal fully with the transmission selector lever in the drive position to select the next lowest gear for optimum performance. Release the accelerator pedal when you no longer require kickdown.

If Your Vehicle Gets Stuck In Mud or Snow

If your vehicle gets stuck in mud or snow, it may be rocked out by shifting between forward and reverse gears, stopping between shifts in a steady pattern. Press lightly on the accelerator in each gear.

Note: Do not rock your vehicle if the engine is not at normal operating temperature or damage to the transmission may occur.

Note: Do not rock your vehicle for more than a minute or damage to the transmission and tires may occur, or the engine may overheat.

Emergency Park Position Release Lever

WARNINGS



Do not drive your vehicle until you verify that the brake lamps are working.



If the parking brake is fully released, but the brake warning lamp remains illuminated, the brakes may not be working correctly. See an authorized dealer.

Use the lever to move the transmission selector lever from the park position in the event of an electrical malfunction or if your vehicle battery has no charge.

1. Apply the parking brake and switch the ignition off before carrying out this procedure.



E161476

2. Remove the center console side panel.

Transmission



E142627

Note: *The lever is pink.*

3. Apply the brake pedal. Using a suitable tool rotate the lever forward while pulling the selector lever out of the park position and into the neutral position.

Note: *See an authorized dealer as soon as possible if this procedure is used.*

Brakes

GENERAL INFORMATION

WARNING



Driving while distracted can result in loss of vehicle control, crash and injury. We strongly recommend that you use extreme caution when using any device that may take your focus off the road. Your primary responsibility is the safe operation of your vehicle. We recommend against the use of any handheld device while driving and encourage the use of voice-operated systems when possible. Make sure you are aware of all applicable local laws that may affect the use of electronic devices while driving.

Note: Occasional brake noise is normal. If a metal-to-metal, continuous grinding or continuous squeal sound is present, the brake linings may be worn-out. If your vehicle has continuous vibration or shudder in the steering wheel while braking, have your vehicle checked by an authorized dealer.

Note: Brake dust may accumulate on the wheels, even under normal driving conditions. Some dust is inevitable as the brakes wear. See **Cleaning the Alloy Wheels** (page 183).

Note: Depending upon certain laws and regulations, the brake lamps may flash during heavy braking. Following this your hazard warning flashers may also flash when your vehicle comes to a stop.

Wet brakes result in reduced braking efficiency. Gently press the brake pedal a few times when driving from a car wash or standing water to dry the brakes.

Brake Assist

Brake assist detects when you brake heavily by measuring the rate at which you press the brake pedal. It provides maximum braking efficiency as long as you press the pedal. Brake assist can reduce stopping distances in critical situations.

Anti-lock Brake System

This system helps you maintain steering control and vehicle stability during emergency stops by keeping the brakes from locking.

HINTS ON DRIVING WITH ANTI-LOCK BRAKES

Note: When the system is operating, the brake pedal will pulse and may travel further. Maintain pressure on the brake pedal. You may also hear a noise from the system. This is normal.

The anti-lock braking system will not eliminate the risks when:

- you drive too closely to the vehicle in front of you
- your vehicle is hydroplaning
- you take corners too fast
- the road surface is poor.

PARKING BRAKE

Note: If you park your vehicle on a hill and facing uphill turn the steering wheel away from the curb.

Note: If you park your vehicle on a hill and facing downhill turn the steering wheel toward the curb.

Note: Do not press the release button while pulling the lever up.

To apply the parking brake:

Brakes

1. Press the foot brake pedal firmly.
2. Pull the parking brake lever up to its fullest extent.

To release the parking brake:

1. Press the brake pedal firmly.
2. Pull the lever up slightly.
3. Press the release button and push the lever down.

HILL START ASSIST - VEHICLES WITH: AUTOMATIC TRANSMISSION

WARNINGS

 The system does not replace the parking brake. When you leave your vehicle, always apply the parking brake. Failure to leave your vehicle securely parked may lead to a crash or injury. See **Parking Brake** (page 118).

 You must remain in your vehicle once the system activates. Failure to follow this warning could result in serious personal injury or death.

 During all times, you are responsible for controlling your vehicle, supervising the system and intervening, if required. Failure to take care may result in the loss of control of your vehicle, serious personal injury or death.

 The system will turn off if a malfunction is apparent or if you rev the engine excessively. Failure to take care may result in the loss of control of your vehicle, serious personal injury or death.

The system makes it easier to pull away when your vehicle is on a slope without the need to use the parking brake.

When the system is active, your vehicle will remain stationary on the slope for two to three seconds after you release the brake pedal. This allows time to move your foot from the brake to the accelerator pedal. The brakes are released automatically once the engine has developed sufficient drive to prevent your vehicle from rolling down the slope. This is an advantage when pulling away on a slope, for example from a car park ramp, traffic lights or when reversing uphill into a parking space.

The system will turn on automatically on any slope which can result in significant vehicle rollback.

Using Hill Start Assist

1. Press the brake pedal to bring your vehicle to a complete standstill. Keep the brake pedal pressed.
2. If the sensors detect that your vehicle is on a slope, the system will activate automatically.
3. When you remove your foot from the brake pedal, your vehicle will remain on the slope without rolling away for approximately two to three seconds. This hold time will automatically be extended if you are in the process of driving off.
4. Drive off in the normal manner. The brakes will be released automatically.

HILL START ASSIST - VEHICLES WITH: MANUAL TRANSMISSION

WARNINGS

 The system does not replace the parking brake. When you leave your vehicle, always apply the parking brake. Failure to leave your vehicle securely parked may lead to a crash or injury. See **Parking Brake** (page 118).

Brakes

WARNINGS



You must remain in your vehicle once the system activates. This could result in the loss of vehicle control, serious personal injury or death.



During all times, you are responsible for controlling your vehicle, supervising the system and intervening, if required. Failure to take care may result in the loss of control of your vehicle, serious personal injury or death.



The system will turn off if a malfunction is apparent or if you rev the engine excessively. Failure to take care may result in the loss of control of your vehicle, serious personal injury or death.

The system makes it easier to pull away when your vehicle is on a slope without the need to use the parking brake.

When the system is active, your vehicle will remain stationary on the slope for two to three seconds after you release the brake pedal. This allows time to move your foot from the brake to the accelerator pedal. The brakes are released automatically once the engine has developed sufficient drive to prevent your vehicle from rolling down the slope. This is an advantage when pulling away on a slope, for example from a car park ramp, traffic lights or when reversing uphill into a parking space.

Using Hill Start Assist

1. Press the brake pedal to bring your vehicle to a complete standstill. Keep the brake pedal pressed.
2. If the sensors detect that your vehicle is on a slope, the system will activate automatically.

3. When you remove your foot from the brake pedal, your vehicle will remain on the slope without rolling away for approximately two to three seconds. This hold time will automatically be extended if you are in the process of driving off.
4. Drive off in the normal manner. The brakes will be released automatically.

Switching the System On and Off

Your vehicle comes with this feature already enabled. If required, you can switch this feature off using the information display. See **General Information** (page 63).

The system will remain on or off depending on how it was last set.

Traction Control

PRINCIPLE OF OPERATION

The traction control system helps avoid drive wheel spin and loss of traction.

If your vehicle begins to slide, the system applies the brakes to individual wheels and, when needed, reduces engine power at the same time. If the wheels spin when accelerating on slippery or loose surfaces, the system reduces engine power in order to increase traction.

USING TRACTION CONTROL

The system automatically turns on each time you switch the ignition on.

Switching the System Off and On Using the Information Display Controls

Your vehicle comes with this feature already enabled. If required, you can switch this feature off using the information display controls.

When you switch the system off, stability control remains fully active.

Switching the System Off Using a Switch (If Equipped)

The switch is located in the instrument panel.

Press the switch. You will see a message in conjunction with an illuminated icon in the display. Press the switch again to return the system to normal mode.

When you switch the system off, stability control remains fully active.

Stability Control

PRINCIPLE OF OPERATION

Electronic Stability Program

WARNING

 The system does not relieve you of your responsibility to drive with due care and attention. Failure to do so could result in loss of vehicle control, personal injury or death.

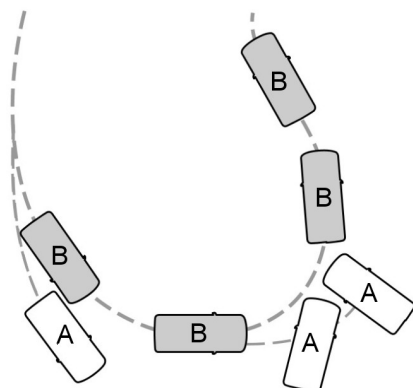

E72903

- A Without ESP
- B With ESP

The system supports stability when your vehicle starts to slide away from your intended path. The system performs this by braking individual wheels and reducing engine torque as required.

The system also provides an enhanced traction control function by reducing engine torque if the wheels spin when you accelerate. This improves your ability to pull away on slippery roads or loose surfaces, and improves comfort by limiting wheel spin in hairpin bends.

Stability Control Warning Lamp

While driving, it flashes when the system is operating. See **Warning Lamps and Indicators** (page 59).

USING STABILITY CONTROL

The system automatically turns on each time you switch the ignition on.

Switching the System Off and On Using the Information Display Controls

Your vehicle comes with this feature already enabled. If required, you can switch this feature off using the information display. See **General Information** (page 63).

Stability control will remain on even when you have switched the traction control off.

Switching the System Off Using a Switch (If Equipped)

The switch is located in the instrument panel.

Press the switch. You will see a message in conjunction with an illuminated icon in the display. Press the switch again to return the system to normal mode.

Stability control will remain on even when you have switched the traction control off.

Parking Aids

PRINCIPLE OF OPERATION

WARNINGS



The system does not relieve you of your responsibility to drive with due care and attention.



If your vehicle has a non-Ford approved trailer tow module the system may not correctly detect objects.



The sensors may not detect objects in heavy rain or other conditions that cause disruptive reflections.



The sensors may not detect objects with surfaces that absorb ultrasonic waves.



The system does not detect objects that are moving away from your vehicle. They will only be detected shortly after they start to move toward your vehicle.



Take particular care when reversing with a tow ball arm or a rear fitted accessory. For example, a bicycle carrier. The rear parking aid will only indicate the approximate distance from the rear bumper to an object.



If you use a high pressure spray to wash your vehicle, only spray the sensors briefly from a distance not less than eight inches (20 centimeters).

Note: If your vehicle has a tow ball arm, the system is turned off automatically when trailer lamps (or lighting boards) are connected to the 13-pin socket through a Ford approved trailer tow module.

Note: Keep the sensors free from dirt, ice or snow. Do not clean with sharp objects.

Note: The system may emit false alerts if it detects a signal using the same frequency as the sensors or if your vehicle is fully loaded.

Note: The outer sensors may detect the side walls of a garage. If the distance between the outer sensors and the side wall remains constant for three seconds, the alert will turn off. As you continue the inner sensors will detect objects directly behind your vehicle.

PARKING AID

WARNINGS



Sensing is only an aid to detect some objects when moving forward or backward at low speeds. Traffic control systems, inclement weather or an external motor and fan can affect the sensors; this may include reduced performance or false activation. To help avoid personal injury you must read and understand the limitations of the system detailed in this section.



The parking aid system may not prevent contact with small or moving objects that are close to the ground. The parking aid system gives an audible warning when it detects a large object helping to avoid damage to your vehicle. To help avoid personal injury you must take care when using the parking aid system.

Note: Some add-on equipment can cause reduced performance or false activation. For example, large trailer hitches, bike or surfboard racks.

Note: The parking aid system sensors must be kept clean and free from snow or ice to avoid reduced performance or false activation. Do not clean the sensors with sharp objects.

Note: If the parking aid sensors are misaligned due to vehicle bumper damage it will cause reduced performance or false activation.

Parking Aids

The parking aid system gives an audible warning and reduces the radio volume when it detects a large object within a limited range of your vehicle's bumpers.

Note: *When the parking aid system no longer detects a large object the radio volume will return to the previous level.*

Rear Sensing System

The rear parking aid sensors turn on automatically when you move the transmission selector lever to **R** (reverse) and your vehicle is moving at a speed of less than 3 mph (5 km/h). Moving your vehicle closer to a large object will increase the audible warning repeat rate. When the object is less than 12 inches (30 centimeters) from the center of your vehicle's rear bumper the audible warning will sound continuously. If the object is more than 12 inches (30 centimeters) from the side of your vehicle's rear bumper the audible warning will sound for three seconds. If the object is less than 12 inches (30 centimeters) from the side of your vehicle's rear bumper the audible warning will sound continuously.

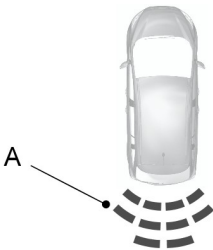

E130178

- A The rear parking aid sensor coverage area is up to 72 inches (183 centimeters) from the center of your vehicle's rear bumper. There is a decreased coverage area at the outer corners.

The system detects large objects when you move the transmission selector lever to **R** (reverse):

- and your vehicle is moving toward the object at a speed of less than 3 mph (5 km/h)
- and your vehicle is not moving but a moving object is approaching the rear of your vehicle at a speed of less than 3 mph (5 km/h)
- and your vehicle is moving at a speed of less than 3 mph (5 km/h) and a moving object is approaching the rear of your vehicle at a speed of less than 3 mph (5 km/h).

Move the transmission selector lever from **R** (reverse) or press the parking aid button to switch the system off. If a fault is present in the system, a warning message appears in the information display and does not allow you to switch the system on.

Front and Rear Sensing System

The front and rear parking aid sensors turn on automatically when you move the transmission selector lever to **R** (reverse), **D** (drive) or **L** (low) and your vehicle is moving at a speed of less than 7 mph (12 km/h).

Parking Aids

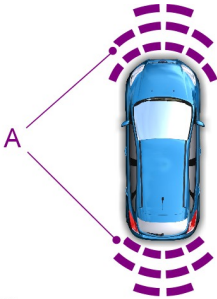

E130382

- A The front parking aid sensor coverage area is up to 31 inches (80 centimeters) from the center of your vehicle's front bumper and up to 14 inches (35 centimeters) to the side of your vehicle's front bumper. The rear parking aid sensor coverage area is up to 72 inches (183 centimeters) from the center of your vehicle's rear bumper. There is a decreased coverage area at the outer corners.

Audible warnings will sound when large objects are within the sensor coverage areas of either bumper in the following manner:

- You will hear a high-pitched tone from the front audio system speakers when large objects are within the sensor coverage area of your vehicle's front bumper. Moving your vehicle closer to a large object will increase the audible warning repeat rate.
- You will hear a lower-pitched tone from the rear audio system speakers when large objects are within the sensor coverage area of your vehicle's rear bumper. Moving your vehicle closer to a large object will increase the audible warning repeat rate.

- The parking aid system prioritises audible warnings based on large objects that are the closest to your vehicle's front or rear bumper. For example, if an object is 24 inches (60 centimeters) from your vehicle's front bumper and at the same time, an object is only 16 inches (40 centimeters) from your vehicle's rear bumper, you will hear the lower-pitched tone from the rear audio system speakers.
- You will hear an alternating audible warning from the front and rear audio system speakers if large objects are less than 12 inches (30 centimeters) from your vehicle's front and rear bumpers.
- If the object is more than 12 inches (30 centimeters) from the side of your vehicle's bumper area the audible warning will sound for three seconds. If the object is less than 12 inches (30 centimeters) from the side of your vehicle's bumper area the audible warning will sound continuously.

Move the transmission selector lever from **R** (reverse), **D** (drive), **L** (low) or move away from large objects as you drive off, or press the parking aid button to switch the system off. For item location: See **At a Glance** (page 12). If a fault is present in the system, a warning message appears in the information display and does not allow you to switch the system on.

REAR VIEW CAMERA

WARNINGS



The rear view camera system is a reverse aid supplement device that still requires the driver to use it in conjunction with the interior and exterior mirrors for maximum coverage.

Parking Aids

WARNINGS



The camera may not detect objects that are very close to your vehicle.



Back up as slow as possible since higher speeds might limit your reaction time to stop the vehicle.

Note: *The operation of the camera may vary depending on the ambient temperature, vehicle and road conditions.*



E165580



E165579

The camera is located on the rear cargo door or liftgate.

Switching the Rear View Camera On

Switch the ignition and the audio unit on.

Move the transmission selector lever to reverse (R).

You will see the image in the audio unit or the interior mirror.

The camera may not operate correctly in the following conditions:

- Dark areas.
- Intense light areas.
- If there is a sudden change to the ambient temperature.
- If the camera is wet.
- If the camera is obstructed.

Using the Display

WARNINGS



Objects in the display are closer than they appear.



Objects above the camera may not be visible. Check the area behind your vehicle when necessary.

Distance markers are only a guide and are calculated for unloaded vehicles on an even road surface.

The lines show a projected vehicle path and the approximate distance from the rear bumper to an object.

Parking Aids

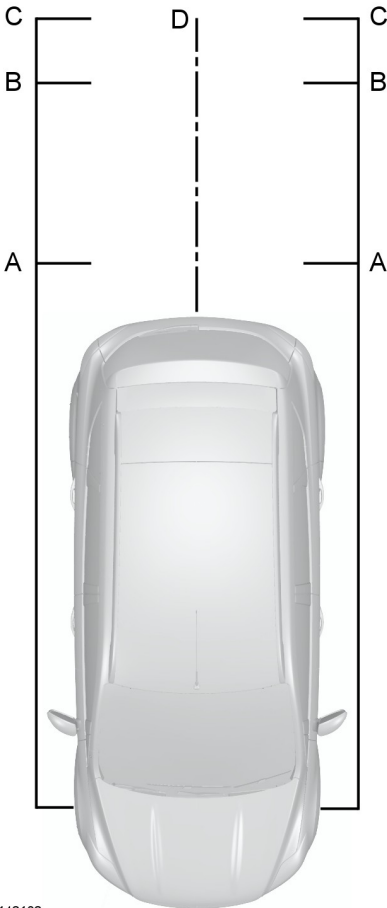

E142132

- A Red - Zone
- B Amber - Zone
- C Green - Zone
- D Black - center line of the projected vehicle path

Note: When reversing with a trailer the camera will show the direction of your vehicle and not the direction of the trailer.

Note: When reversing with a trailer the screen does not display the lines.

Switching the Rear View Camera Off

Move the transmission selector lever from reverse (R).

Note: The system will automatically switch off after disengaging reverse gear.

Vehicles with Parking Aid (If Equipped)

The display will show a colored distance bar. This indicates the approximate distance from the rear bumper to an object.

These are color coded as follows:

- Red - Zone
- Amber - Zone
- Green - Zone

Cruise Control

PRINCIPLE OF OPERATION

Cruise control lets you maintain a set speed without keeping your foot on the accelerator pedal.

USING CRUISE CONTROL

WARNINGS



Do not use cruise control in heavy traffic, on winding roads or when the road surface is slippery. This could result in loss of vehicle control, serious injury or death.



When you are going downhill, your vehicle speed may increase above the set speed. The system will not apply the brakes. Change down a gear to assist the system in maintaining the set speed. Failure to do so could result in loss of vehicle control, serious injury or death.

Note: Cruise control will disengage if your vehicle speed decreases more than 10 mph (16 km/h) below your set speed while driving uphill.



E142437

The cruise control switches are located on the steering wheel.

Switching Cruise Control On

Press and release **ON**.



The indicator will display in the instrument cluster.

Setting a Speed

1. Accelerate to the desired speed.
2. Press and release **SET+**.
3. Take your foot off the accelerator pedal.

Changing the Set Speed

- Press and hold **SET+** or **SET-**. Release the control when you reach the desired speed.
- Press and release **SET+** or **SET-**. The set speed will change in approximately 1 mph (2 km/h) increments.
- Press the accelerator or brake pedal until you reach the desired speed. Press and release **SET+**.

Canceling the Set Speed

Pull **CAN** toward you and release, or tap the brake pedal. The system will not erase the set speed.

Resuming the Set Speed

Pull **RES** toward you and release.

Switching Cruise Control Off

Note: You will erase the set speed if you switch the system off.

Press and release **OFF** or switch the ignition off.

Driving Aids

SPEED LIMITER

Principle of Operation

WARNING



When you are going downhill, your vehicle speed may increase above the set speed. The system will not apply the brakes but a warning will be given.

The system allows you to set a speed, to which your vehicle then becomes limited. The set speed will become the effective maximum speed of your vehicle, but with the option to temporarily exceed this limit if required.

Using the System

The system is operated by adjustment controls mounted on the steering wheel.



E133198

- A Set speed increase
- B On and off
- C Set speed decrease
- D Cancel and resume

Note: The set speed limit can be intentionally exceeded for a short period of time if required, for example when overtaking.

Switching the System On and Off

Press switch B. The information display will prompt you to set a speed.

Setting the Speed Limit

Use the cruise control switches to alter the maximum speed setting.

Press switch A or C to select your desired speed limit. The speed is displayed in the information display and stored as the set speed.

Pull switch D to cancel the limiter and place it in standby mode. The information display will confirm this has been turned off by showing the set speed crossed out.

Pull switch D again to resume the limiter. The information display will confirm this has been turned on by showing the set speed again.

Intentionally Exceeding the Set Speed Limit

Depress the accelerator fully to temporarily turn the system off, this will be indicated in the information Display. The system will turn on once your vehicle speed drops below the set speed.

System Warnings

If you exceed the set speed, a warning will flash in the information display and you will hear a warning chime.

Driving Aids

ACTIVE CITY STOP

Principle of Operation

WARNINGS

 You are responsible for controlling your vehicle at all times. The system does not relieve you of your responsibility to drive with due care and attention. Failure to take care may result in the loss of control of your vehicle, serious personal injury or death.

 To achieve full system performance you must break in the braking system. See **Breaking-In** (page 141). Failure to take care may result in the loss of control of your vehicle, serious personal injury or death.

 If the system applies the brakes and the engine stops the hazard warning flashers will automatically turn on. Failure to take care may lead to a crash or personal injury.

 The system does not react to cyclists, motorcyclists, pedestrians, animals or vehicles that are driving in a different direction. Failure to take care may result in the loss of control of your vehicle, serious personal injury or death.

 The system does not operate during harsh acceleration or steering. Failure to take care may lead to a crash or personal injury.

 The system may not operate during cold or severe weather conditions. Snow, ice, heavy rain and spray can influence the system. Keep the hood free of snow and ice. Failure to take care may result in the loss of control of your vehicle, serious personal injury or death.

 The system may not operate when driving around sharp curves. Failure to take care may lead to a crash or personal injury.

WARNINGS

 The system may not operate correctly if you replace the windshield with a non-Ford windshield. Do not carry out windshield repairs in front of the sensor. Failure to adhere to this warning may lead to an accident or injury.

 The system may not detect objects with surfaces that absorb reflections. Failure to take care may result in the loss of control of your vehicle, serious personal injury or death.

 The system will not operate correctly if the sensor is blocked. Keep the windshield free from obstructions, for example, bird droppings, insects, snow or ice. Failure to adhere to this warning may lead to an accident or injury.

 When you switch the ignition on the sensor transmits a laser beam. Never look directly into the sensor. There is a risk of eye injury.

The sensor is on the rear of the interior mirror. It continuously monitors conditions to decide when to intervene.

The system operates at speeds below approximately 19 mph (30 km/h) by applying the brakes if it detects that a crash is likely. If the system applies the brakes a message will appear in the information display.

The system may reduce the risk of a low speed crash into another vehicle. It also helps reduce impact damage or may avoid the crash completely.

Note: *You must depress the brake pedal to obtain full braking force.*

Driving Aids

Switching the System Off and On

Your vehicle comes with this feature already enabled. If required, you can switch this feature off using the information display controls. See **General Information** (page 63).

Note: *The system automatically turns on every time you switch the ignition on.*







In certain situations we recommend that you switch the system off, for example:

- driving off-road when objects may cover the windshield
- driving through a car wash facility.

Load Carrying

GENERAL INFORMATION

WARNINGS

-  Use load securing straps to an approved standard, e.g. DIN.
-  Make sure that you secure all loose items properly.
-  Place luggage and other loads as low and as far forward as possible within the luggage or loadspace.
-  Do not drive with the liftgate or rear door open. Exhaust fumes may enter your vehicle.
-  Do not exceed the maximum front and rear axle loads for your vehicle. See **Vehicle Identification Plate** (page 204).
-  Do not allow items to contact the rear windows.

Note: When loading long objects in to your vehicle, for example pipes, timber or furniture be careful not to damage the interior trim.

REAR UNDER FLOOR STORAGE

Passenger Compartment Floor

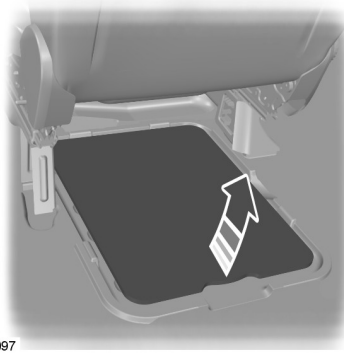

E78097

The under floor storage compartment is located behind the front passenger seat.

Cargo Management System (if Equipped)

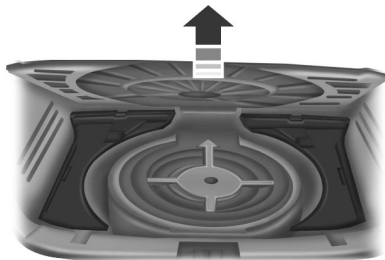

E142445

The system is located in the floor of the cargo area. Lift the handle to open.

Load Carrying

Adjustable Load Floor (If Equipped)

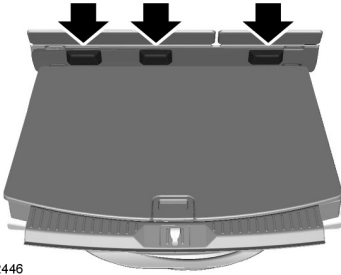

E142446

Vehicles with the standard size spare tire can adjust the load floor to two positions. The front of the load floor can be placed either on (for high position) or below (for low position) the ledges behind the rear seats. The rear of the load floor always sits on the two small shelves located on the liftgate trim.

LUGGAGE ANCHOR POINTS

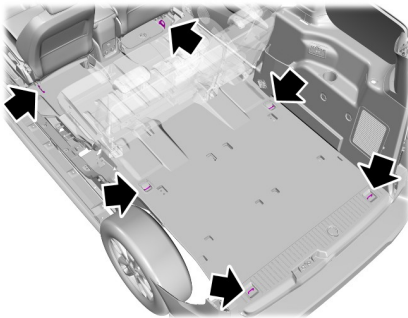

E167350



CARGO NETS

Installing the Net

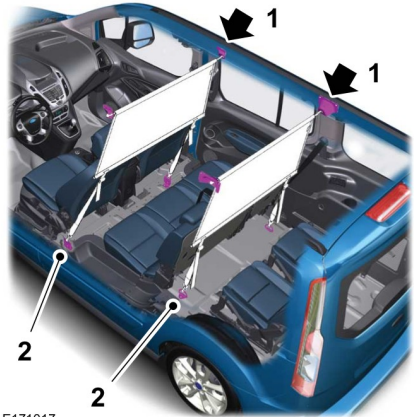

E171017

1. Push the ends of the upper bar toward each other and insert them into the retainers in the roof. Push the bar forward into the narrow section of the retainers.

Load Carrying

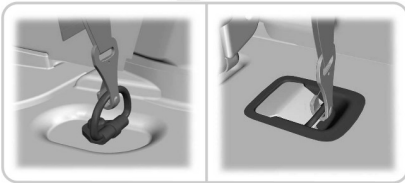
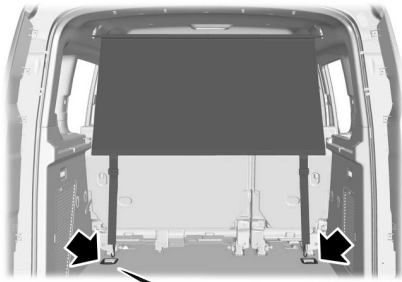

E167370

2. Attach the net to the luggage anchor points. See **Luggage Anchor Points** (page 133).

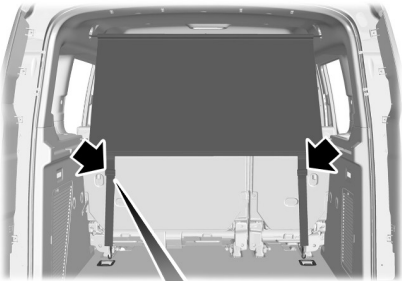

E167371

3. Tighten the straps.

Removing the Net

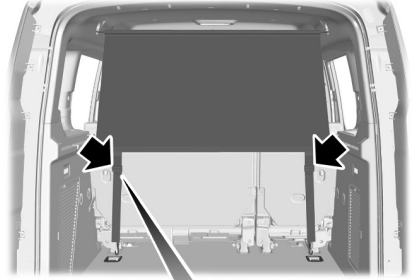

E167372

1. Release the straps.
2. Remove the net from the luggage anchor points.
3. Remove the upper bars.

ROOF RACKS AND LOAD CARRIERS

WARNINGS



Read and follow the manufacturer's instructions when you are fitting a roof rack. Failure to take care may lead to a crash or personal injury.

Load Carrying

WARNINGS



When loading the roof rack we recommend you evenly distribute the load, as well as maintain a low center of gravity. Loaded vehicles, with high centers of gravity handle differently than unloaded vehicles. Take extra precautions, use slower speeds and increased stopping distances. Failure to take care may result in the loss of control of your vehicle, serious personal injury or death.

For correct roof rack system function, you must place loads directly on crossbars fitted to the roof rack side rails. When using the roof rack system, we recommend you use Ford genuine accessory crossbars designed specifically for your vehicle.

Make sure that you securely fasten the load. Check the tightness of the load before driving and at each fuel stop.

Note: *If you use a roof rack, the fuel consumption of your vehicle will be higher and you may experience different driving characteristics.*

Note: *Never place loads directly on the roof panel.*

Maximum Load Weights

Do not exceed the following maximum roof rack load weights.

Variant	Maximum Load lb (kg)*
Kombi	165 lb (75 kg)
Van	220 lb (100 kg)
Double Cab	220 lb (100 kg)

*Evenly distribute the load on the roof rack.

Towing

TOWING A TRAILER

WARNINGS



Do not exceed 62 mph (100 km/h). This could result in the loss of vehicle control, serious personal injury or death.



The rear tire pressures must be increased by 3 psi (0.2 bar) above specification. Do not exceed the maximum pressure stated on the tire sidewall. This could cause serious personal injury. See **Wheels and Tires** (page 184).



Do not exceed the maximum gross train weight stated on your vehicle identification plate. This could result in the loss of vehicle control, serious personal injury or death. See **Vehicle Identification Plate** (page 204).



Do not exceed the maximum permissible trailer nose weight (vertical weight on the tow ball) as stated in the vehicle specification chart. This could result in the loss of vehicle control, serious personal injury or death. See **Capacities and Specifications** (page 201).



The anti-lock braking system does not control the overrun brake on the trailer. This could result in the loss of vehicle control, serious personal injury or death.

When towing a trailer:

- Obey country specific regulations for towing a trailer.
- Do not exceed 62 mph (100 km/h) even if a country allows higher speeds under certain conditions.

- Place loads as low as possible and central to the axle of your trailer. If you are towing with an unladen vehicle, the load in your trailer should be placed toward the nose, within the maximum nose load, as this gives the best stability. See **Capacities and Specifications** (page 201).
- The trailer nose weight (vertical weight on the tow ball), is essential for the driving stability of your vehicle and trailer.
- The vertical weight on the tow ball should be at least 4% of the trailer weight and not exceed the maximum permissible weight. See **Capacities and Specifications** (page 201).
- Reduce speed immediately if the trailer shows any sign of swaying. See **Trailer Sway Control** (page 137).
- Use a low gear when descending a steep downhill gradient.

Note: *The maximum permissible trailer nose weight on the trailer identification plate is the trailer manufacturer's testing value. The vehicle maximum permissible trailer nose weight may be lower.*

The stability of your vehicle to trailer combination is very much dependent on the quality of the trailer.

Towing a trailer changes the vehicle handling characteristics and increases stopping distances. Adapt your speed and driving behavior to the load of the trailer.

The gross train weight stated on the vehicle identification plate applies for road gradients up to 12% and altitudes up to 3281 feet (1000 meters) when towing a trailer. In mountainous regions the engine performance decreases due to lower air

Towing

density with increasing altitude. In high altitude regions above 3281feet (1000 metres), the stipulated maximum permitted gross train weight must be reduced by 10% for every extra 3281 feet (1000 metres).

Note: *Not all vehicles are suitable or approved to have tow bars fitted. See an authorized dealer for further information.*

Trailer Lighting

The electrical system on your vehicle is not suitable for towing trailers with LED lamps.

TRAILER SWAY CONTROL

This feature applies your vehicle brakes at individual wheels and if necessary, reduces engine power. If the trailer begins to sway, the traction control warning lamp will flash.

Stop your vehicle as soon as it is safe to do so and check for correct trailer nose weight (vertical weight on the tow ball) and trailer load distribution. See

Capacities and Specifications (page 201). See **Load Carrying** (page 132).

Note: *This feature does not prevent trailer sway, but reduces it once it begins.*

Note: *This feature cannot stop all trailers from swaying.*

Note: *In some cases, if your vehicle speed is too high, the system may turn on multiple times, gradually reducing your vehicle speed.*

TOWING POINTS

WARNING



The towing eye has a left-hand thread. Turn it counterclockwise to install it. Make sure that the towing eye is fully tightened. Failure to do so could result in the towing hook becoming loose.

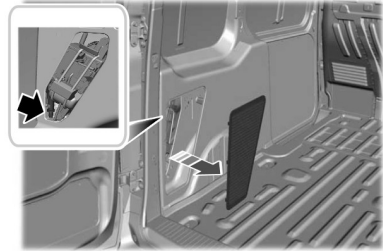

E165020

Space is provided in the luggage compartment on the left-hand side.

You must carry the towing eye in your vehicle at all times.

Front Towing Eye

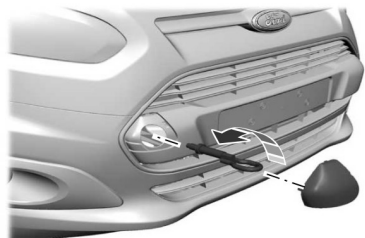

E165018

Remove the cover and install the towing eye.

Towing

Rear Towing Eye



E165019

Remove the cover and install the towing eye.

Note: *If your vehicle has a tow bar, you cannot install the towing eye at the rear of your vehicle. Use the tow bar to tow other vehicles.*

TOWING THE VEHICLE ON FOUR WHEELS - VEHICLES WITH: AUTOMATIC TRANSMISSION

WARNINGS



You must switch the ignition on when your vehicle is being towed. Failure to follow this warning could seriously increase the risk of injury or death.



You must make sure the transmission selector lever is placed in position **N**. Failure to follow this warning could damage the transmission and may lead to a crash or injury.



The brake and steering assistance will not operate unless the engine is running. Press the brake pedal harder and allow for increased stopping distances and heavier steering. Failure to take care may lead to a crash or personal injury.



Too much tension on a tow rope could cause damage to your vehicle or the vehicle that is towing.

Emergency Towing

If your vehicle is disabled without access to wheel dollies, a car-hauling trailer, or a flatbed transport vehicle it can be flat-towed with all wheels on the ground.

You may do this under the following conditions:

- Your vehicle is facing forward so that it is towed in a forward direction.
- The transmission selector lever is placed in position **N**. If the transmission gear shift lever cannot be moved to position **N**, it may need to be overridden. See **Automatic Transmission** (page 114).
- Maximum speed is 35 mph (56 km/h).
- Maximum distance is 50 miles (80 kilometers).

Drive off slowly and smoothly without jerking the vehicle that is being towed.

You must only use the towing eye that was delivered with your vehicle. See **Towing Points** (page 137).

Tow ropes or rigid towing bars must be placed on the same side. For example; right hand rear towing point to right hand front towing point.

You must use a tow rope or rigid towing bar that is of the correct strength for the weight of the towing vehicle and the vehicle that is being towed.





Note: *Using a rigid towing bar is the safest way to tow a vehicle.*

The weight of the vehicle that is being towed must not exceed the weight of the towing vehicle.

Towing

TOWING THE VEHICLE ON FOUR WHEELS - VEHICLES WITH: MANUAL TRANSMISSION

WARNINGS

-  You must switch the ignition on when your vehicle is being towed. Failure to follow this warning could seriously increase the risk of injury or death.
-  The brake and steering assistance will not operate unless the engine is running. Press the brake pedal harder and allow for increased stopping distances and heavier steering. Failure to take care may lead to a crash or personal injury.
-  Too much tension on a tow rope could cause damage to your vehicle or the vehicle that is towing.
-  When towing your vehicle you must select neutral. Failure to follow this warning could damage the transmission and may lead to a crash or injury.

Drive off slowly and smoothly without jerking the vehicle that is being towed.

You must only use the towing eye that was delivered with your vehicle. See **Towing Points** (page 137).

Tow ropes or rigid towing bars must be placed on the same side. For example; right hand rear towing point to right hand front towing point.

You must use a tow rope or rigid towing bar that is of the correct strength for the weight of the towing vehicle and the vehicle that is being towed.

Note: *Using a rigid towing bar is the safest way to tow a vehicle.*

The weight of the vehicle that is being towed must not exceed the weight of the towing vehicle.

Do not exceed 30 mph (50 km/h). See **Transporting the Vehicle** (page 139).

TRANSPORTING THE VEHICLE

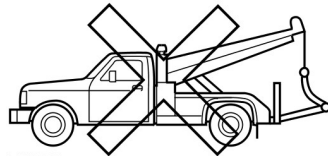
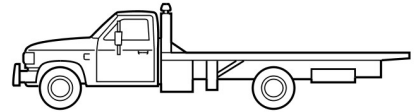
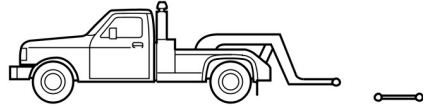

E143886

If you need to have your vehicle towed, contact a professional towing service. If you are a member of a roadside assistance program, contact your roadside assistance service provider.

When being towed you must use flatbed equipment, or wheel lift equipment and dollies to allow sufficient ground clearance. Do not use slingbelt lifting equipment. This can cause vehicle damage which is not covered by the vehicle warranty.

Towing

Note: *All road wheels must be clear of the ground when being towed to allow sufficient ground clearance.*

Driving Hints

BREAKING-IN

Tires

WARNING



New tires need to be run-in for approximately 300 miles (500 kilometers). During this time, you may experience different driving characteristics.

Brakes and Clutch

WARNING



Avoid heavy use of the brakes and clutch if possible for the first 100 miles (150 kilometers) in town and for the first 1000 miles (1500 kilometers) on freeways.

Engine

WARNING



Avoid driving too fast during the first 1000 miles (1500 kilometers). Vary your speed frequently and change up through the gears early. Do not labor the engine.

ECONOMICAL DRIVING

The following will help to improve fuel consumption.

Tire Pressures

Check your tire pressures regularly to optimize fuel economy. For best results use the economy pressures. See **Technical Specifications** (page 197).

Gear Shifting

Use the highest drivable gear appropriate for the road conditions.

Anticipation

Adjust your vehicle speed and the distance to other vehicles without the need for heavy braking or acceleration.

Efficient Speed

Higher speeds use more fuel. Reduce your cruising speed on open roads.

Accessories

Try not to add unnecessary accessories to the exterior of your vehicle. If you use a roof rack, remember to fold it down or remove it when not in use.

Electrical Systems

Switch off all electrical systems when not in use, for example air conditioning. Make sure you unplug any accessories from the auxiliary power points when not in use.

REDUCED ENGINE PERFORMANCE

WARNING



Continued operation will increase the engine temperature and cause the engine to shut down completely.

If the engine coolant temperature gauge needle moves to the upper limit position, the engine is overheating. See **Gauges** (page 58).

You must only drive your vehicle for a short distance if the engine overheats. The distance you can travel depends on ambient temperature, vehicle load and terrain. The engine will continue to operate with limited power for a short time.

If the engine temperature continues to rise, the fuel supply to the engine will reduce. The air conditioning will switch off and the engine cooling fan will operate continually.

Driving Hints

1. Reduce your speed gradually and stop your vehicle as soon as it is safe to do so.
2. Switch the engine off immediately to prevent severe engine damage.
3. Wait for the engine to cool down.
4. Check the coolant level. See **Engine Coolant Check** (page 167).
5. Have your vehicle checked by an authorized dealer as soon as possible.

COLD WEATHER PRECAUTIONS

The functional operation of some components and systems can be affected at temperatures below -13°F (-25°C).

DRIVING THROUGH WATER

WARNINGS



Drive through water in an emergency only and not as part of normal driving.



Engine damage can occur if water enters the air filter.

In an emergency, you can drive your vehicle through water to a maximum depth of 8 inches (200 millimeters) and at a maximum speed of 6 mph (10 km/h). You must take extra care when driving through flowing water.

When driving in water, maintain a low speed and do not stop your vehicle. After driving through water and as soon as it is safe to do so:

- Depress the brake pedal lightly to check that the brakes are functioning correctly.
- Check that the horn works.

- Check that your vehicle's lamps are fully operational.
- Check the power assistance of the steering system.

FLOOR MATS



E142666

WARNINGS



Always use floor mats that are designed to fit the foot well of your vehicle, leaving the pedal area unobstructed, and which can be firmly secured to retention posts so that they cannot slip out of position and interfere with the pedals or impair safe operation of your vehicle in other ways.



Incorrectly fitted floor mats can cause the accelerator pedal to become stuck in the open position. This can cause loss of vehicle control.



Always correctly install the floor mats to the retention posts so that they cannot slip out of position or obstruct pedal operation.



Do not place unsecured floor mats or any other covering in the foot well.



Do not place additional floor mats or any other covering on top of the original floor mats. This will reduce the pedal clearance and interfere with the pedal operation.

Driving Hints

WARNINGS



Do not allow objects to fall or become trapped under the pedals of your vehicle. This can cause loss of vehicle control.



Carry out regular inspections to make sure the floor mats are secure.

To install the floor mats, position the floor mat eyelet over the retention post and press down to lock in position.

Remove in reverse order.

Roadside Emergencies

HAZARD WARNING FLASHERS



The hazard warning button is located on the instrument panel. Use it when your vehicle is creating a safety hazard for other motorists.

Press the button to turn on the hazard warning function, and the front and rear direction indicators will flash.

Press the button again to turn them off.

Note: *If used when the engine is not running, the battery will lose charge. There may be insufficient power to restart your engine.*

Note: *Depending on applicable laws and regulations in the country for which your vehicle was originally built, the hazard warning flashers may flash if you brake heavily.*

FIRST AID KIT

Space is provided in the overhead console or lower door bins.

WARNING TRIANGLE

Space is provided in the overhead console or lower door bins.

FUEL SHUTOFF

WARNING



Failure to inspect and if necessary repair fuel leaks after a crash may increase the risk of fire and serious injury. We recommend that the fuel system be inspected by an authorized dealer after any crash.

In the event of a moderate to severe crash, your vehicle is equipped with a fuel pump shut-off feature that stops the flow of fuel to the engine. Not every impact will cause a shut-off.

Should the engine turn off after a crash, you may restart the engine by doing the following:

1. Switch the ignition off.
2. Switch the ignition to position **III**.
3. Switch the ignition off.
4. Switch the ignition on again to re-enable the fuel pump.

JUMP-STARTING THE VEHICLE

WARNINGS



Do not use fuel lines, engine rocker covers or the intake manifold as grounding points.



Connect batteries with only the same nominal voltage.



Always use booster cables with insulated clamps and adequate size cable.

Note: *Do not disconnect the battery from your vehicle's electrical system.*

Roadside Emergencies

To Connect the Booster Cables

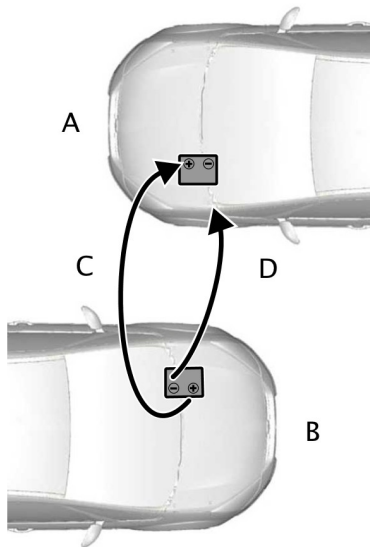

E102925

- A Vehicle with low charge battery
- B Booster battery vehicle
- C Positive connection cable
- D Negative connection cable

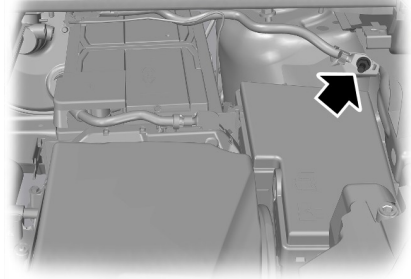

1. Position the vehicles so that they do not touch one another.
2. Switch off the engine and any electrical equipment.
3. Connect the positive (+) terminal of vehicle B with the positive (+) terminal of vehicle A (cable C).



E130431

4. Connect the negative (-) terminal of vehicle B to the ground connection of vehicle A (cable D).

WARNINGS

-  Do not connect directly to the negative (-) terminal of the battery with low charge.
-  Make sure that the cables are clear of any moving parts and fuel delivery system parts.

To Start the Engine

1. Run the engine of vehicle B at a moderately high speed.
2. Start the engine of vehicle A.
3. Run both vehicles for a minimum of three minutes before disconnecting the cables.

WARNING

-  Do not switch on the headlamps when disconnecting the cables. The peak voltage could blow the bulbs.

Disconnect the cables in the reverse order.

Fuses

FUSE BOX LOCATIONS

Engine Compartment Fuse Box

The fuse box is located in the engine compartment. See **Maintenance** (page 158).

Passenger Compartment Fuse Box

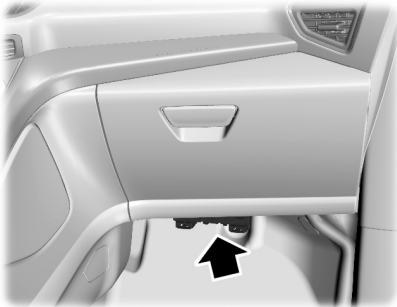

E159113

The fuse box is located below the glove box.

Luggage Compartment Fuse Box



E163779

The fuse box is located in the luggage compartment on the right-hand side. Remove the fuse box cover to gain access to the fuses.

CHANGING A FUSE

Fuses

WARNING



Always replace a fuse with one that has the specified amperage rating. Using a fuse with a higher amperage rating can cause severe wire damage and could start a fire.

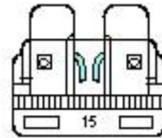

E142430

Fuses

If electrical components in the vehicle are not working, a fuse may have blown. Blown fuses are identified by a broken wire within

the fuse. Check the appropriate fuses before replacing any electrical components.

Standard Fuse Amperage Rating and Color

Fuse rating	Color				
	Mini fuses	Standard fuses	Maxi fuses	Cartridge maxi fuses	Fuse link cartridge
2A	Grey	Grey	-	-	-
3A	Violet	Violet	-	-	-
4A	Pink	Pink	-	-	-
5A	Tan	Tan	-	-	-
7.5A	Brown	Brown	-	-	-
10A	Red	Red	-	-	-
15A	Blue	Blue	-	-	-
20A	Yellow	Yellow	Yellow	Blue	Blue
25A	Natural	Natural	-	Natural	Natural
30A	Green	Green	Green	Pink	Pink
40A	-	-	Orange	Green	Green
50A	-	-	Red	Red	Red
60A	-	-	Blue	Yellow	Yellow
70A	-	-	Tan	-	Brown
80A	-	-	Natural	Black	Black

Fuses

FUSE SPECIFICATION CHART

Engine Compartment Fuse Box

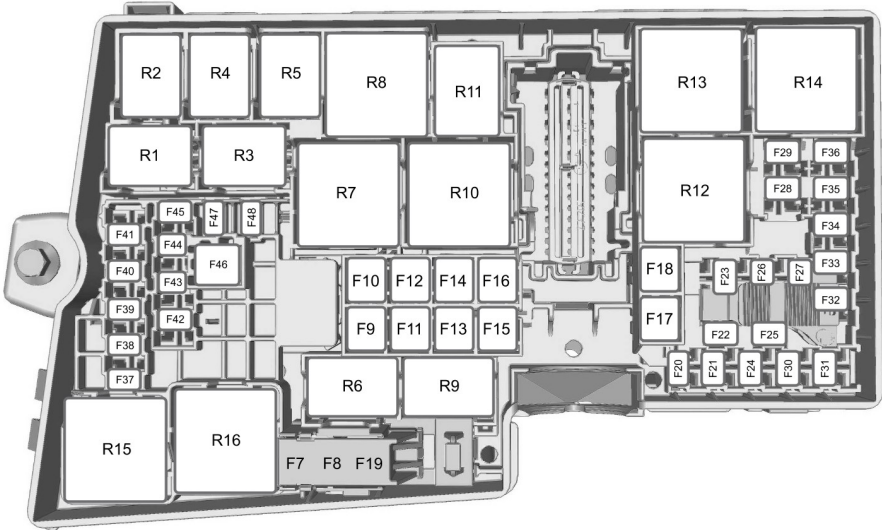

E157389

Fuse	Fuse Rating	Circuits protected
F1	-	Not used
F2	-	Not used
F3	-	Not used
F4	-	Not used
F5	-	Not used
F6	-	Not used
F7	40A**	Anti-lock brake system Electronic stability program
F8	30A**	Stability control

Fuses

Fuse	Fuse Rating	Circuits protected
F9	30A**	Heated rear window
F10	40A**	Blower motor
F11	20A**	Rear floor console auxiliary power point
F12	30A**	Powertrain control module
F13	30A**	Starter relay
F14	40A**	Heated windshield (right-hand side)
F15	20A**	Rear auxiliary power points
	25A	Charge air cooler (1.0L EcoBoost)
F16	40A**	Heated windshield (left-hand side)
F17	20A**	Floor console auxiliary power point
F18	20A	Driver stowage bin auxiliary power point
F19	5A*	Anti-lock brake system Stability Control
F20	15A*	Horn
F21	5A*	Stop lamp switch
F22	15A*	Battery monitor system
	10A	Power supply voltage (powertrain control module)
F23	5A*	Relay coils
F24	25A*	Fuel fired booster heater (van only)
F25	10A	Power mirrors (without door control unit)
F26	5A*	Engine control relay coil feed (vehicles with a gasoline engine)
F26	15A*	Engine control relay coil feed (vehicles with a diesel engine) Transmission control (vehicles with a diesel engine)

Fuses

Fuse	Fuse Rating	Circuits protected
F27	15A*	Air conditioning clutch
F28	5A*	Voltage quality module (ignition)
	25A	Rear power windows (without door control unit)
F29	25A*	Front power windows (without door control unit)
F30	5A	Ignition switch position II output
F31	10A	Security horn
F32	15A*	Engine control module
	10A	Mass air flow solenoid Exhaust gas recirculation solenoid
F33	10A*	Engine control module
	15A	Ignition coil pack
F34	10A*	Fuel injectors
F35	15A*	Fuel filter heater
F36	10A*	Engine control module
	5A	Active grille shutter
F37	5A*	Parking assist control module
F38	15A*	Engine control module
		Transmission control module
F39	5A*	Headlamp leveling
F40	5A*	Electronic power assist steering
F41	20A*	Body control module
F42	15A*	Rear window wiper
F43	15A*	Heated front seat
F44	15A*	Headlamp control module
F45	10A*	Heated washer nozzle

Fuses

Fuse	Fuse Rating	Circuits protected
F46	40A**	Windshield wiper
F47	7.5A	Heated exterior mirror (without door control unit)
F48	25A*	Body control module

*Mini fuses **Cartridge fuses

Relay	Circuits switched
R1	Charge air cooler fan (1.0L EcoBoost)
R2	Horn
R3	Security horn
R4	Not used
R5	Rear window wiper
R6	Not used
R7	Heated windshield
R8	Accessory delay
R9	Ignition
R10	Starter motor
R11	Air conditioning clutch
R12	Cooling fan
R13	Blower motor
R14	Electronic engine control
R15	Heated rear window
R16	Ignition

Fuses

Passenger Compartment Fuse Box

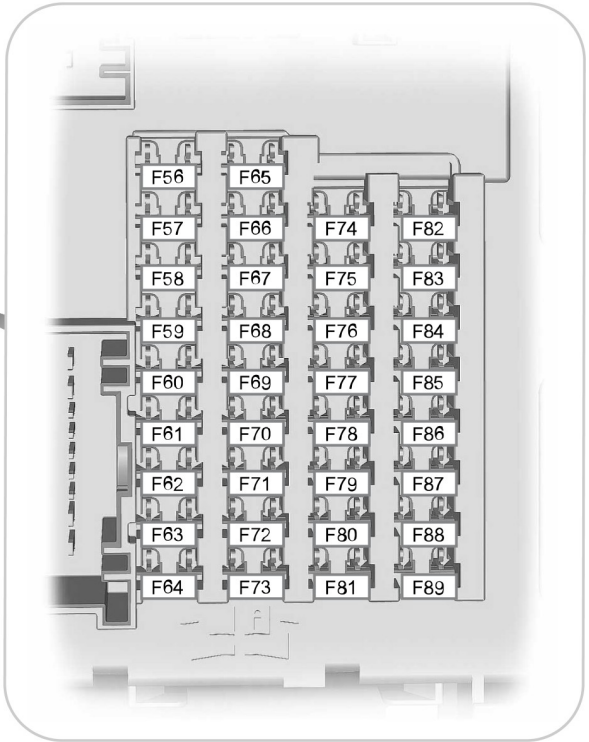
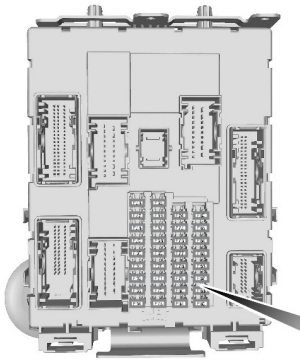

E129926

Fuse	Fuse Rating	Circuits protected
F56	20A	Fuel pump
F57	-	Not used
F58	-	Not used
F59	5A	Passive anti-theft system transceiver
F60	10A	Interior lamp Driver door switch pack Glove compartment lamp

Fuses

Fuse	Fuse Rating	Circuits protected
		Overhead console switch bank
F61	-	Not used
F62	5A	Autowipers Auto-dimming interior mirror
F63	10A	Adaptive cruise control (front sensing module)
F64	-	Not used
F65	10A	Liftgate release
F66	-	Not used
F67	7.5A	SYNC Front display interface module Global positioning system module
F68	15A	Electric steering column lock
F69	5A	Instrument panel cluster
F70	-	Not used
F71	10A	Heating control head (manual air conditioning) Dual automatic temperature control
F72	7.5A	Steering wheel module
F73	7.5A	Data link connector Battery backup sounder
F74	15A	High beam headlamp
F75	15A	Front fog lamp
F76	10A	Reversing lamp
F77	20A	Washer pump
F78	5A	Ignition switch Ignition switch (vehicles with keyless starting)
F79	15A	Audio unit DVD navigation system Touchscreen Hazard flasher switch Door lock switch
F80	20A	Moonroof

Fuses

Fuse	Fuse Rating	Circuits protected
F5	-	Not used
F6	25A	Door control unit (left-hand rear)
F7	25A	Door control unit (right-hand rear)
F8	10A	Security horn
F9	-	Not used
F10	-	Not used
F11	-	Not used
F12	10A	Climate control (vehicles with start-stop)
F13	5A	Instrument panel cluster (vehicles with start-stop)
F14	7.5A	Information and entertainment display SYNC Global positioning system module (vehicles with start-stop)
F15	15A	Audio unit (vehicles with start-stop)
F16	-	Not used
F17	-	Not used
F18	-	Not used
F19	-	Not used
F20	-	Not used
F21	-	Not used
F22	-	Not used
F23	-	Not used
F24	20A	Rear auxiliary power points
F25	40A	Rear blower motor
F26	40A	Accessories Trailer tow module
F27	30A	Voltage quality module
F28	20A	Fuel fired booster heater

Fuses

Fuse	Fuse Rating	Circuits protected
F29	5A	Blind spot monitoring system Front view camera Adaptive cruise control Rear view camera with park assist Low voltage DC/DC converter ignition signal
F30	5A	Parking aid
F31	-	Not used
F32	-	Not used
F33	-	Not used
F34	15A	Driver heated seat
F35	15A	Passenger heated seat
F36	-	Not used
F37	20A	Power sunblind
F38	-	Not used
F39	-	Not used
F40	7.5A	Ignition (Rear heating, ventilation and air conditioning module)
F41	-	Not used
F42	-	Not used
F43	-	Not used
F44	-	Not used
F45	-	Not used
F46	5A	Rear view camera with park assist (vehicles with start-stop)

Relay	Circuits switched
R1	Ignition switch
R2	Rear heating, ventilation and air conditioning motor
R3	Not used

Fuses

Relay	Circuits switched
R4	Not used
R5	Security horn
R6	Not used

Maintenance

GENERAL INFORMATION

Have your vehicle serviced regularly to help maintain its roadworthiness and resale value. There is a large network of Ford authorized repairers that are there to help you with their professional servicing expertise. Authorized repairers are best qualified to service your vehicle properly and expertly, with a wide range of highly specialized tools.

In addition to regular servicing, we recommend that you carry out the following checks.

WARNINGS



Switch the ignition off before touching or attempting adjustment of any kind.



Do not touch the electronic ignition system parts after you have switched the ignition on or when the engine is running. The system operates at high voltage.



Keep your hands and clothing clear of the engine cooling fan. Under certain conditions, the fan may continue to run for several minutes after you have switched the engine off.



Make sure that you fit filler caps securely after carrying out maintenance checks.

Daily Checks

- Exterior lamps.
- Interior lamps.
- Warning lamps and indicators.

Check When Refueling

- Engine oil level. See **Engine Oil Check** (page 166).
- Brake fluid level. See **Brake and Clutch Fluid Check** (page 167).

- Washer fluid level. See **Washer Fluid Check** (page 168).
- Tire pressures (when cold). See **Technical Specifications** (page 188).
- Tire condition. See **Wheels and Tires** (page 184).

Monthly Checks

- Engine coolant level (engine cold). See **Engine Coolant Check** (page 167).
- Pipes, hoses and reservoirs for leaks.
- Air conditioning operation.
- Parking brake operation.
- Horn operation.
- Tightness of lug nuts. See **Technical Specifications** (page 188).

OPENING AND CLOSING THE HOOD

Opening the Hood

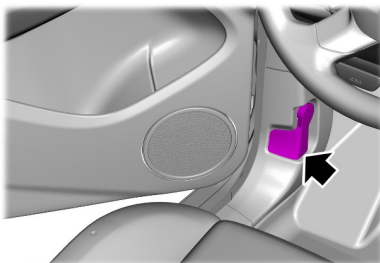

E164919

1. Open the front door.
2. Pull the hood release handle.

Maintenance

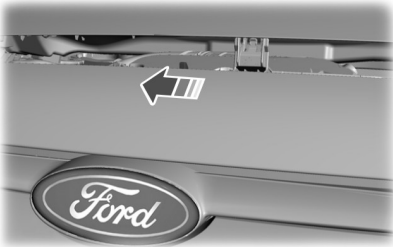

E164920

3. Move the catch to the left.

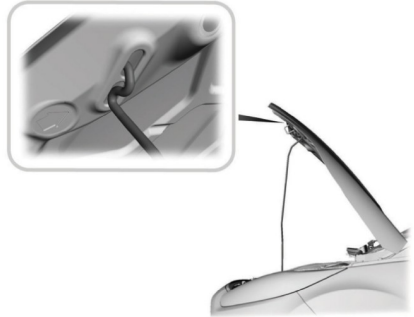

E87786

4. Open the hood and support it with the support rod.

Closing the Hood

1. Remove the support rod from the catch and secure correctly.
2. Lower the hood and allow it to drop under its own weight for the last 8 inches to 12 inches (20 centimeters to 30 centimeters).

Note: *Make sure the hood is fully closed.*

Maintenance

UNDER HOOD OVERVIEW - 1.0L ECOBOOST (74KW/100PS), VEHICLES WITH: LHD

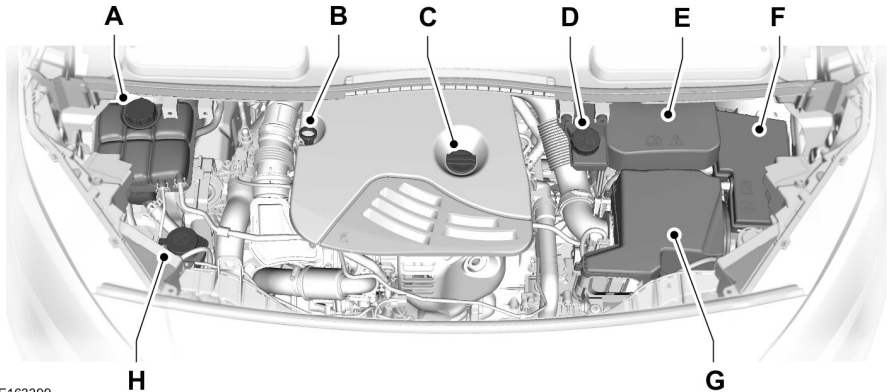

E163399

- A Engine coolant reservoir*: See **Engine Coolant Check** (page 167).
- B Engine oil dipstick*: See **Engine Oil Check** (page 166).
- C Engine oil filler cap*: See **Engine Oil Check** (page 166).
- D Brake and clutch fluid reservoir*: See **Brake and Clutch Fluid Check** (page 167).
- E Battery: See **Changing the 12V Battery** (page 168).
- F Engine compartment fuse box: See **Fuses** (page 146).
- G Air cleaner: No maintenance necessary.
- H Windshield and rear window washer fluid reservoir: See **Washer Fluid Check** (page 168).

* The filler caps and the engine oil dipstick are colored for easy identification.

Maintenance

UNDER HOOD OVERVIEW - 1.0L ECOBOOST (74KW/100PS), VEHICLES WITH: RHD

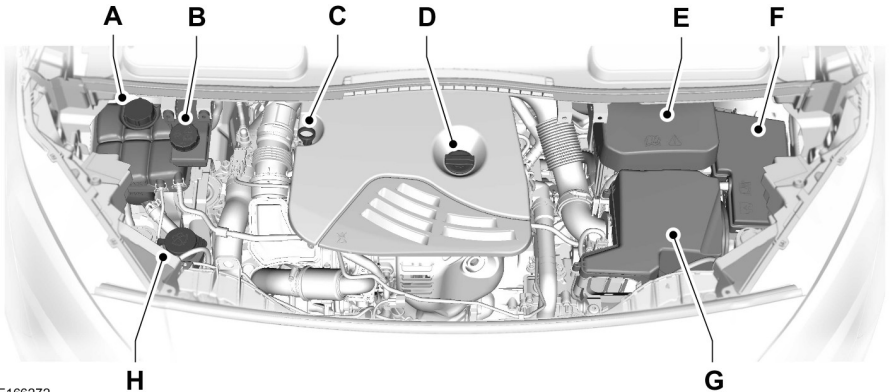

E166272

- A Engine coolant reservoir*: See **Engine Coolant Check** (page 167).
- B Brake and clutch fluid reservoir*: See **Brake and Clutch Fluid Check** (page 167).
- C Engine oil dipstick*: See **Engine Oil Check** (page 166).
- D Engine oil filler cap*: See **Engine Oil Check** (page 166).
- E Battery: See **Changing the 12V Battery** (page 168).
- F Engine compartment fuse box: See **Fuses** (page 146).
- G Air cleaner: No maintenance necessary.
- H Windshield and rear window washer fluid reservoir: See **Washer Fluid Check** (page 168).

* The filler caps and the engine oil dipstick are colored for easy identification.

Maintenance

UNDER HOOD OVERVIEW - 1.6L ECOBOOST (110KW/150PS) - SIGMA, VEHICLES WITH: LHD

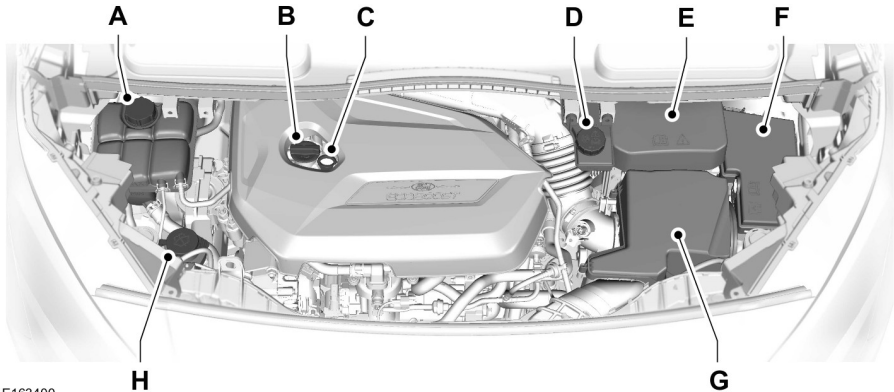

E163400

- A Engine coolant reservoir*: See **Engine Coolant Check** (page 167).
- B Engine oil filler cap*: See **Engine Oil Check** (page 166).
- C Engine oil dipstick*: See **Engine Oil Check** (page 166).
- D Brake and clutch fluid reservoir*: See **Brake and Clutch Fluid Check** (page 167).
- E Battery: See **Changing the 12V Battery** (page 168).
- F Engine compartment fuse box: See **Fuses** (page 146).
- G Air cleaner: No maintenance necessary.
- H Windshield and rear window washer fluid reservoir: See **Washer Fluid Check** (page 168).

* The filler caps and the engine oil dipstick are colored for easy identification.

Maintenance

UNDER HOOD OVERVIEW - 1.6L ECOBOOST (110KW/150PS) - SIGMA, VEHICLES WITH: RHD

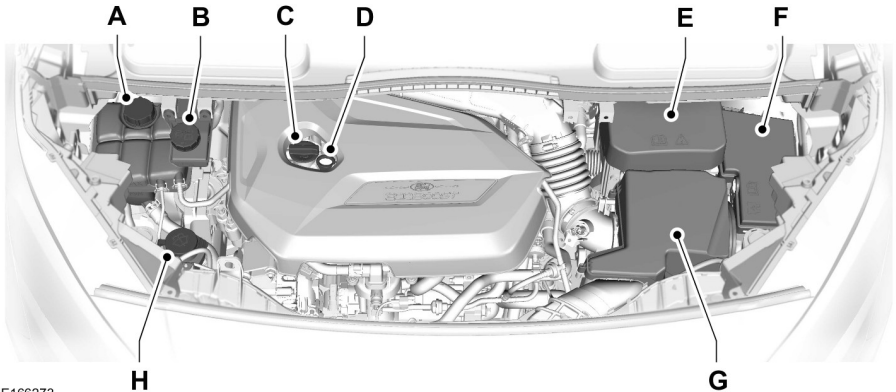

E166273

- A Engine coolant reservoir*: See **Engine Coolant Check** (page 167).
- B Brake and clutch fluid reservoir*: See **Brake and Clutch Fluid Check** (page 167).
- C Engine oil filler cap*: See **Engine Oil Check** (page 166).
- D Engine oil dipstick*: See **Engine Oil Check** (page 166).
- E Battery: See **Changing the 12V Battery** (page 168).
- F Engine compartment fuse box: See **Fuses** (page 146).
- G Air cleaner: No maintenance necessary.
- H Windshield and rear window washer fluid reservoir: See **Washer Fluid Check** (page 168).

* The filler caps and the engine oil dipstick are colored for easy identification.

Maintenance

UNDER HOOD OVERVIEW - 1.6L DURATORQ-TDCI (DV) DIESEL, VEHICLES WITH: LHD

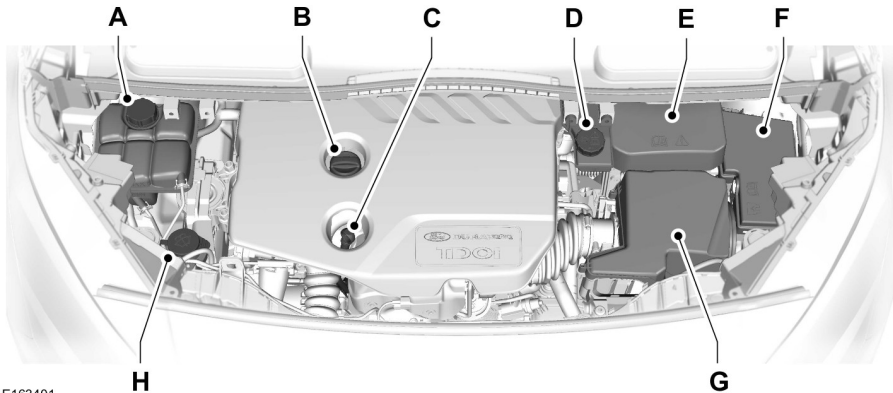

E163401

- A Engine coolant reservoir*: See **Engine Coolant Check** (page 167).
- B Engine oil filler cap*: See **Engine Oil Check** (page 166).
- C Engine oil dipstick*: See **Engine Oil Check** (page 166).
- D Brake and clutch fluid reservoir*: See **Brake and Clutch Fluid Check** (page 167).
- E Battery: See **Changing the 12V Battery** (page 168).
- F Engine compartment fuse box: See **Fuses** (page 146).
- G Air cleaner: No maintenance necessary.
- H Windshield and rear window washer fluid reservoir: See **Washer Fluid Check** (page 168).

* The filler caps and the engine oil dipstick are colored for easy identification.

Maintenance

UNDER HOOD OVERVIEW - 1.6L DURATORQ-TDCI (DV) DIESEL, VEHICLES WITH: RHD

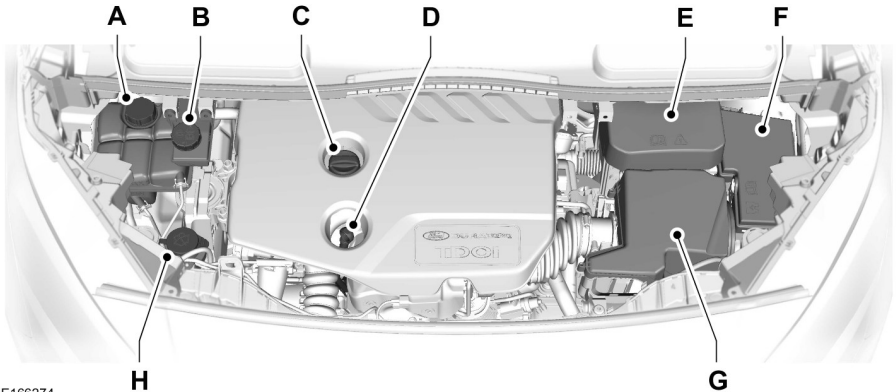

E166274

- A Engine coolant reservoir*: See **Engine Coolant Check** (page 167).
- B Brake and clutch fluid reservoir*: See **Brake and Clutch Fluid Check** (page 167).
- C Engine oil filler cap*: See **Engine Oil Check** (page 166).
- D Engine oil dipstick*: See **Engine Oil Check** (page 166).
- E Battery: See **Changing the 12V Battery** (page 168).
- F Engine compartment fuse box: See **Fuses** (page 146).
- G Air cleaner: No maintenance necessary.
- H Windshield and rear window washer fluid reservoir: See **Washer Fluid Check** (page 168).

* The filler caps and the engine oil dipstick are colored for easy identification.

Maintenance

ENGINE OIL DIPSTICK - 1.0L ECOBOOST (74KW/100PS)

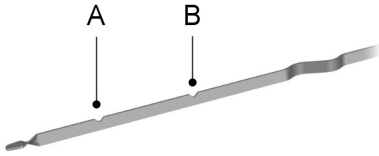

E141337

- A Minimum
- B Maximum

ENGINE OIL DIPSTICK - 1.6L DURATORQ-TDCI (DV) DIESEL

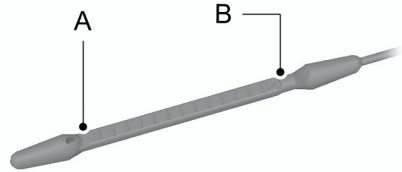

E140423

- A Minimum
- B Maximum

ENGINE OIL DIPSTICK - 1.6L ECOBOOST (110KW/150PS) - SIGMA

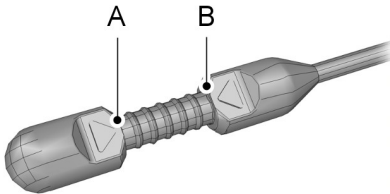

E134114

- A Minimum
- B Maximum

ENGINE OIL CHECK

1. Make sure that your vehicle is on level ground.
2. Switch off the engine and wait 10 minutes for the oil to drain into the oil pan.
3. Remove the dipstick and wipe it with a clean, lint free cloth. Replace the dipstick and remove it again to check the oil level.

If the oil level is at the minimum mark, add oil immediately. See **Technical Specifications** (page 176).

Note: Check the oil level before starting the engine.

Note: Make sure that the oil level is between the minimum and the maximum marks.

Note: Do not use oil additives or other engine treatments. Under certain conditions, they could damage the engine.

Note: The oil consumption of new engines reaches its normal level after approximately 3000 mi (5,000 km).

Maintenance

Adding Engine Oil

WARNINGS



Only add oil when the engine is cold. If the engine is hot, wait 10 minutes for the engine to cool down.



Do not remove the filler cap when the engine is running.

1. Remove the engine oil filler cap.
2. Add engine oil that meets Ford specifications. See **Technical Specifications** (page 176).
3. Replace the engine oil filler cap. Turn it until you feel a strong resistance.

Note: Do not add oil further than the maximum mark. Oil levels above the maximum mark may cause engine damage.

Note: Soak up any spillage with an absorbent cloth immediately.

ENGINE COOLANT CHECK

WARNING



Do not allow the fluid to touch your skin or eyes. If this happens, rinse the affected areas immediately with plenty of water and contact your physician.

Note: Make sure that the level is between the **MIN** and the **MAX** marks.

Note: Coolant expands when it is hot. The level may therefore extend beyond the **MAX** mark.

If the level is at the **MIN** mark, add coolant immediately.

Adding Engine Coolant

WARNINGS



Only add coolant when the engine is cold. If the engine is hot, wait 10 minutes for the engine to cool down.

WARNINGS



Do not remove the filler cap when the engine is running.



Do not remove the filler cap when the engine is hot. Wait for the engine to cool down.



Undiluted coolant is flammable and may ignite if spilled on a hot exhaust.

Note: In an emergency, you can add just water to the cooling system to reach a vehicle service station. Have the system checked by an authorized dealer as soon as possible.

Note: Prolonged use of incorrect dilution of the coolant can cause engine damage from corrosion, overheating or freezing.

Note: Do not add coolant further than the **MAX** mark.

1. Remove the filler cap. Any pressure will escape slowly as you unscrew the cap.
2. Add a 50/50 mixture of coolant and water using fluid that meets the Ford specifications. See **Technical Specifications** (page 179).
3. Replace the filler cap. Turn it until you feel a strong resistance.

BRAKE AND CLUTCH FLUID CHECK

WARNINGS



Use of any fluid other than the recommended brake fluid may reduce brake efficiency and not meet Ford's performance standards.



Do not allow the fluid to touch your skin or eyes. If this happens, rinse the affected areas immediately with plenty of water and contact your physician.

Maintenance

WARNINGS



If the level is at the **MIN** mark, have the system checked by an authorized dealer as soon as possible.

Note: *Keep brake fluid clean and dry. Contamination with dirt, water, petroleum products or other materials may result in brake system damage and possible failure.*

Note: *The brake and the clutch systems are supplied from the same reservoir.*

Add fluid that meets the Ford specification. See **Technical Specifications** (page 176).

WASHER FLUID CHECK

Note: *The reservoir supplies the front and rear washer systems.*

When adding fluid, use a mixture of washer fluid and water to help prevent freezing in cold weather and improve the cleaning capability. We recommend that you use only high quality washer fluid.

For information on fluid dilution, refer to the product instructions.

CHANGING THE 12V BATTERY

WARNING



For vehicles with Start-Stop the battery requirement is different. You must replace the battery with one of exactly the same specification.

The battery is located in the engine compartment. See **Maintenance** (page 158).

Note: *You must reset the bounce-back feature for the power windows. See **Power Windows** (page 53).*



Make sure that you dispose of old batteries in an environmentally friendly way.

Seek advice from your local authority about recycling old batteries.

CHECKING THE WIPER BLADES



E142463

Run the tip of your fingers over the edge of the blade to check for roughness.

Clean the wiper blades with washer fluid or water applied with a soft sponge or cloth.

CHANGING THE WIPER BLADES

You can manually move the wiper arms when you switch the ignition off. Pull the wiper blade and wiper arm away from the glass. This allows for ease of wiper blade replacement and cleaning under the wiper blades.

Replace wiper blades at least once per year for optimum performance.

Poor wiper quality can be improved by cleaning the wiper blades and the windshield.

Changing the Front Wiper Blades

1. Pull the wiper blade and arm away from the glass.

Maintenance

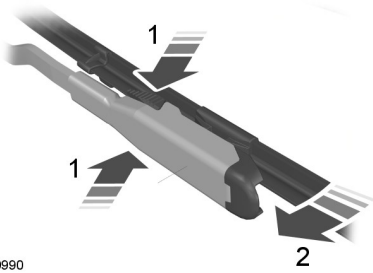

E129990

2. Press the locking buttons together.
3. Rotate and remove the wiper blade.
4. Install in the reverse order.

Note: Make sure that the wiper blade locks into place. Lower the wiper arm and blade back to the windshield. The wiper arms will automatically return to their normal position when you switch the ignition on.

Rear Window Wiper Blades

Liftgate

1. Lift the wiper arm.

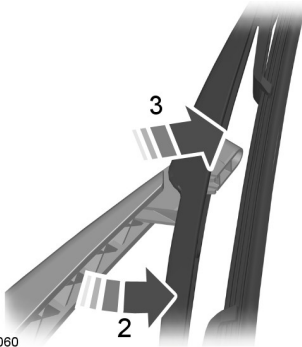

E130060

2. Slightly rotate the wiper blade from the wiper arm.
3. Disengage the wiper blade from the wiper arm.

4. Remove the wiper blade.

Install new wiper blades in the reverse order.

Note: Make sure that the wiper blade locks into place.

Double Rear Doors

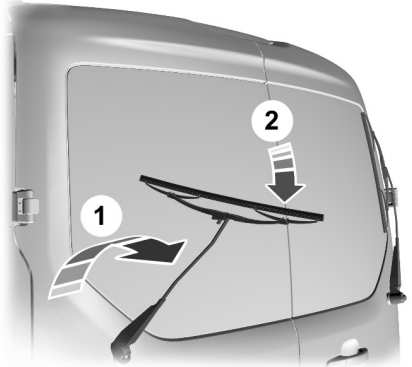

E165586

1. Lift the wiper arm.
2. Position the wiper blade at right angles to the wiper arm.

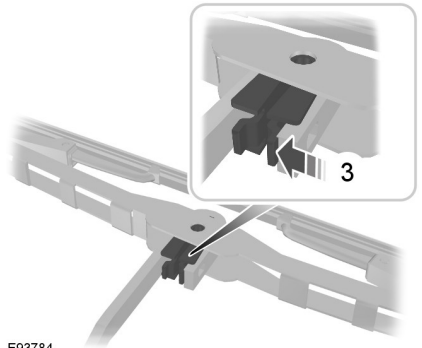

E93784

3. Disengage the wiper blade from the wiper arm.

Maintenance

WARNINGS



Bulbs can become hot, let the bulb cool down before removing it. Failure to do so could result in personal injury.

The following instructions describe how to remove the bulbs. Fit replacements in the reverse order unless otherwise stated.

You must fit bulbs of the correct specification. See **Bulb Specification Chart** (page 174).

Note: We recommend that you see an authorized dealer to change the headlamp bulbs if your vehicle is fitted with air conditioning. Some bulbs are difficult to access.

Headlamp

Remove the covers to gain access to the bulbs.

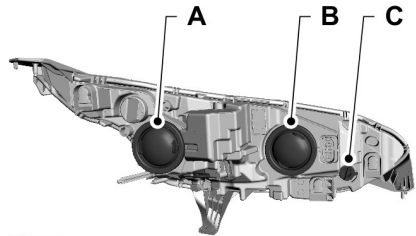

E165474

- A Headlamp low beam and side lamp
- B Headlamp high beam
- C Direction indicator

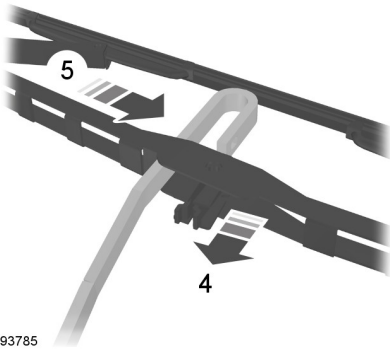

E93785

4. Unhook the wiper blade from the wiper arm.
5. Slide the wiper blade to the side.

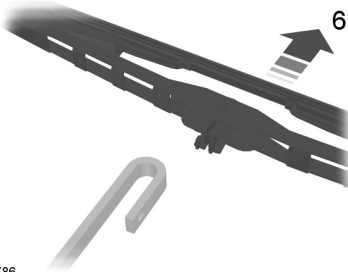

E93786

6. Remove the wiper blade.
- Install new wiper blades in the reverse order.

Note: Make sure that the wiper blade locks into place.

CHANGING A BULB

WARNINGS



Switch the lamps and the ignition off. Failure to do so could result in serious personal injury.

Maintenance

Side Lamp

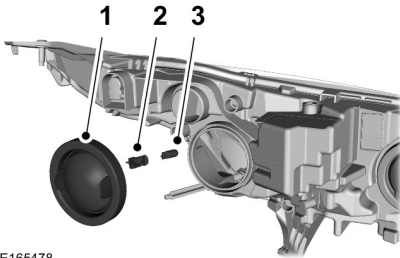

E165478

1. Remove the cover.
2. Remove the bulb holder by pulling it straight out.
3. Remove the bulb from the bulb holder by pulling it straight out.

Direction Indicator

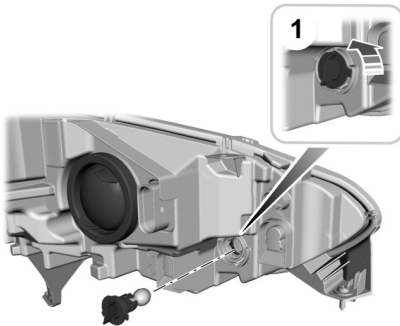

E165475

1. Turn the bulb holder counterclockwise and remove it.

Note: You cannot separate the bulb from the bulb holder.

Headlamp Low Beam

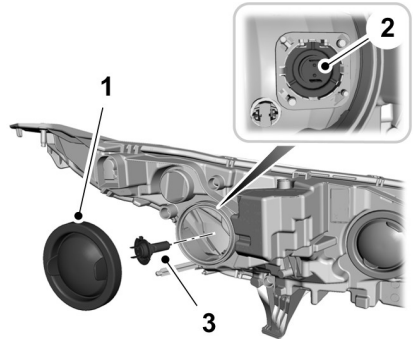

E165477

1. Remove the cover.
2. Disconnect the electrical connector.
3. Remove the bulb by pulling it straight out.

Note: Do not touch the glass of the bulb.

Headlamp High Beam

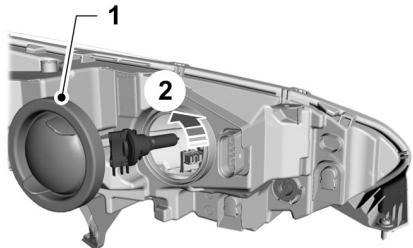

E165476

1. Remove the cover.
2. Turn the bulb counterclockwise and remove it.

Note: Do not touch the glass of the bulb.

Maintenance

Side Direction Indicator

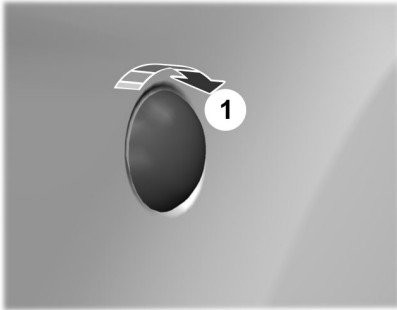

E165495

1. Turn the lamp clockwise and remove it.

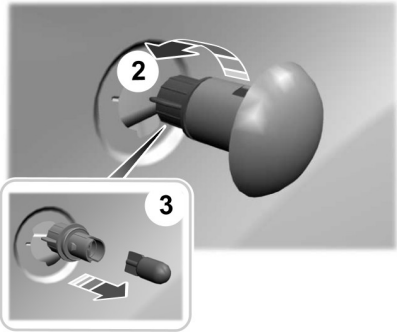

E165496

2. Hold the bulb holder and turn the lamp counterclockwise and remove it.
3. Remove the bulb by pulling it straight out.

Front Fog Lamps

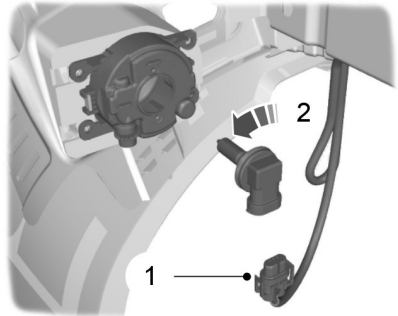

E71062

1. Disconnect the electrical connector.
2. Turn the bulb holder counterclockwise and remove it.

Note: Do not touch the glass of the bulb.

Note: You cannot separate the bulb from the bulb holder.

Rear Lamps

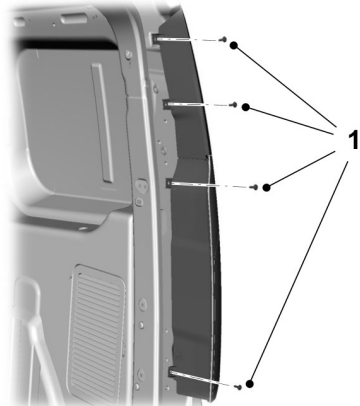

E165484

1. Remove the screws.

Maintenance

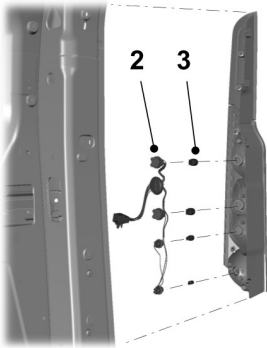

E165485

2. Turn the bulb holders counterclockwise to remove them.
3. Remove the bulbs by pulling them straight out.

Central High Mounted Brake Lamp

These are not serviceable items, see an authorized dealer if they fail.

License Plate Lamp

These are not serviceable items, see an authorized dealer if they fail.

Interior Lamps

Front Interior Lamp

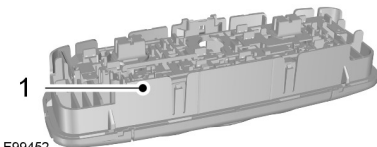
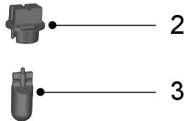

E99452

1. Carefully remove the lamp.

2. Turn the bulb holder counterclockwise and remove it.

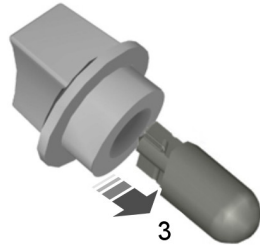

E73939

3. Remove the bulb by pulling it straight out.

Reading Lamps

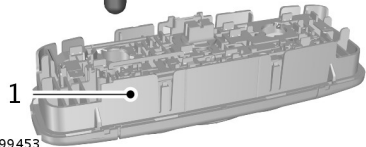
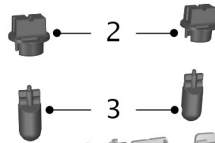

E99453

1. Carefully remove the lamp.
2. Turn the bulb holder counterclockwise and remove it.
3. Remove the bulb by pulling it straight out.

Maintenance

Cargo Area Lamp

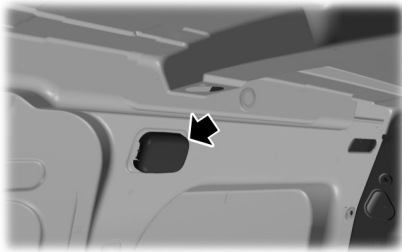

E163429

1. Prise off the lamp cover.

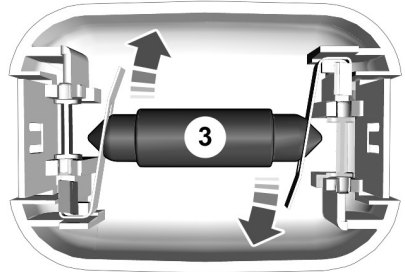
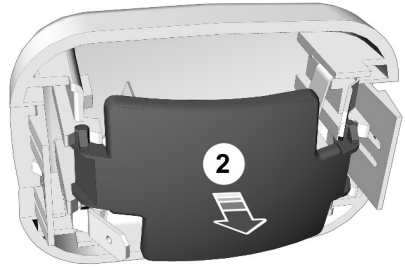

E166153

2. Remove the cover.
3. Remove the bulb.

BULB SPECIFICATION CHART

Lamp	Specification	Power (watt)
Approach lamp	W5W	5
Brake and tail lamp	P21/5W	21/5
Cornering lamp	H1	55
Front direction indicator	PY24W	24
Front fog lamp	H11	55
Headlamp high beam	H15	55
Headlamp low beam	H7	55
License plate lamp	W5W	5

Maintenance

Lamp	Specification	Power (watt)
Luggage compartment lamp	211 Festoon	10
Rear direction indicator	PY21W	21
Rear fog lamp	P21W	21
Reversing lamp	W16W	16
Side repeater	WY5W	5

Maintenance

TECHNICAL SPECIFICATIONS - 1.0L ECOBOOST (74KW/100PS)

Vehicle Fluids

Item	Specification	Viscosity Grade	Recommended fluid
Engine oil	WSS-M2C948-B	5W-20	Castrol Engine Oil Ford Engine Oil
Engine coolant	WSS-M97B44-D	-	Antifreeze Super Plus Premium
	WSS-M97B44-D2	-	Motorcraft Anti- freeze Super Plus Premium Ready Mix
Brake fluid	WSS-M6C65-A2 or ISO 4925 Class 6	-	Brake Fluid DOT 4 LV High Perform- ance

Use oil and fluids that meet the defined specification and viscosity grades. If you use oil and fluids that do not meet the defined specification and viscosity grade this may lead to:

- component damage which is not covered by the vehicle warranty
- longer engine cranking periods
- increased emission levels
- reduced engine performance
- reduced fuel economy.

We recommend Castrol Engine Oil and Ford Engine Oil.



Maintenance

Item	Quantity
Windshield and rear window washer system - including headlamp washer	0.7 gal (3 L)
Engine cooling system	1.3 gal (5.85 L)
Fuel tank	13.2 gal (60 L)
Engine lubrication system - including the oil filter	0.9 gal (4.1 L)
Engine lubrication system - excluding the oil filter	0.8 gal (4 L)

Engine Oil Adding Capacities

Quantity
0.2 gal (1 L)

Maintenance

TECHNICAL SPECIFICATIONS - 1.6L DURATORQ-TDCI (DV) DIESEL

Vehicle Fluids

Item	Specification	Viscosity Grade	Recommended fluid
Engine oil	WSS-M2C913-D	5W-30	Castrol Engine Oil Ford Engine Oil
Engine coolant	WSS-M97B44-D	-	Antifreeze Super Plus Premium
	WSS-M97B44-D2	-	Motorcraft Anti-freeze Super Plus Premium Ready Mix
Brake fluid	WSS-M6C65-A2 ISO 4925 Class 6	-	Brake Fluid DOT 4 LV High Performance

Use oil and fluids that meet the defined specification and viscosity grades. If you use oil and fluids that do not meet the defined specification and viscosity grade this may lead to:

- component damage which is not covered by the vehicle warranty
- longer engine cranking periods
- increased emission levels
- reduced engine performance
- reduced fuel economy.

We recommend Castrol Engine Oil and Ford Engine Oil.



Maintenance

Item	Quantity
Windshield and rear window washer system - including headlamp washer	0.7 gal (3 L)
Engine cooling system	1.6 gal (7.3 L)
Fuel tank	13.2 gal (60 L)
Engine lubrication system - including the oil filter	1.4 gal (6.2 L)
Engine lubrication system - excluding the oil filter	5.8 gal (1.3 L)

Engine Oil Adding Capacities

Quantity
0.5 gal (2.4 L)

*The amount of oil required to raise the level on the dipstick from minimum to maximum.

TECHNICAL SPECIFICATIONS - 1.6L ECOBOOST (110KW/150PS) - SIGMA

Vehicle Fluids

Item	Specification	Viscosity Grade	Recommended fluid
Engine oil	WSS-M2C948-B	5W-20	Castrol Engine Oil Ford Engine Oil
Alternative engine oil	WSS-M2C913-C	5W-30	Castrol Engine Oil Ford Engine Oil
Engine coolant	WSS-M97B44-D	-	Motorcraft Anti-freeze Super Plus Premium

Maintenance

Item	Specification	Viscosity Grade	Recommended fluid
	WSS-M97B44-D2	-	Motorcraft Anti-freeze Super Plus Premium Ready Mix
Brake fluid	WSS-M6C65-A2 ISO 4925 Class 6	-	Motorcraft Brake Fluid DOT 4 LV High Performance

Adding oil: If you are unable to find an oil that meets the specification defined by WSS-M2C948-B or WSS-M2C913-C, you must use SAE 5W-30 that meets the specification defined by ACEA A5/B5.

Use oil and fluids that meet the defined specification and viscosity grades. If you use oil and fluids that do not meet the defined specification and viscosity grade this may lead to:

- component damage which is not covered by the vehicle warranty
- longer engine cranking periods
- increased emission levels
- reduced engine performance
- reduced fuel economy.

We recommend Castrol Engine Oil and Ford Engine Oil.



Item	Quantity
Windshield and rear window washer system - including headlamp washer	0.7 gal (3 L)
Engine cooling system	2 gal (9.1 L)
Fuel tank	13.2 gal (60 L)
Engine lubrication system - including the oil filter	0.9 gal (4.1 L)
Engine lubrication system - excluding the oil filter	0.8 gal (3.75 L)

Maintenance

Engine Oil Adding Capacities





Quantity
0.2 gal (0.75 L)

*The amount of oil required to raise the level on the dipstick from minimum to maximum.

Vehicle Care

CLEANING THE EXTERIOR



WARNINGS

-  If you use a car wash with a waxing cycle, make sure that you remove the wax from the windshield.
-  Prior to using a car wash facility check the suitability of it for your vehicle.
-  Some car wash installations use water at high pressure. This could damage certain parts of your vehicle.
-  Remove the aerial before using an automatic car wash.
-  Switch the heater blower off to prevent contamination of the fresh air filter.

We recommend that you wash your vehicle with a sponge and lukewarm water containing a car shampoo.

Cleaning the Headlamps

WARNINGS

-  Do not scrape the headlamp lenses or use abrasives, alcoholic solvents or chemical solvents to clean them.
-  Do not wipe the headlamps when they are dry.

Cleaning the Rear Window



WARNING

-  Do not scrape the inside of the rear window or use abrasives or chemical solvents to clean it.

Use a clean, lint free cloth or a damp chamois leather to clean the inside of the rear window.



Cleaning the Chrome Trim

WARNINGS

-  Do not use abrasives or chemical solvents. Use soapy water.
-  Do not apply cleaning product to hot surfaces and do not leave cleaning product on chrome surfaces for a period of time exceeding that which is recommended.
-  Industrial-strength (heavy-duty) cleaners, or cleaning chemicals, may cause damage over a period of time.

Body Paintwork Preservation

WARNINGS

-  Do not polish your vehicle in strong sunshine.
-  Do not allow polish to touch plastic surfaces. It could be difficult to remove.
-  Do not apply polish to the windshield or rear window. This could cause the wipers to become noisy and they may not clear the window properly.

We recommend that you wax the paintwork once or twice a year.

REPAIRING MINOR PAINT DAMAGE

You should repair paintwork damage caused by stones from the road or minor scratches as soon as possible. A choice of products are available from an authorized dealer.

Remove particles such as bird droppings, tree sap, insect deposits, tar spots, road salt and industrial fallout before repairing paint chips.

Vehicle Care

Always read and follow the manufacturer's instructions before using the products.

CLEANING THE INTERIOR

Note: Do not allow air fresheners and hand sanitizers to spill on interior surfaces. If a spill occurs, wipe off immediately. Damage may not be covered by your warranty.

Safety Belts

WARNINGS



Do not use abrasives, or chemical solvents to clean them.



Do not allow moisture to penetrate the safety belt retractor mechanism.

Clean them with interior cleaner or water applied with a soft sponge. Let them dry naturally, away from artificial heat.

Instrument Cluster Screens, LCD Screens and Radio Screens

WARNING



Do not use abrasives, alcoholic solvents or chemical solvents to clean them.

Rear Windows

WARNING



Do not use any abrasive materials to clean the interior of the rear windows.

Note: Do not install stickers or labels to the interior of the rear windows.

CLEANING THE ALLOY WHEELS

Note: Do not apply a cleaning chemical to warm or hot wheel rims and covers.

Note: Industrial-strength (heavy-duty) cleaners, or cleaning chemicals, in combination with brush agitation to remove brake dust and dirt, could wear away the clear coat finish over a period of time.

Note: Do not use hydrofluoric acid-based or high caustic-based wheel cleaners, steel wool, fuels or strong household detergent.

Note: If you intend parking your vehicle for an extended period after cleaning the wheels with a wheel cleaner, drive your vehicle for a few minutes before doing so. This will reduce the risk of increased corrosion of the brake discs, brake pads and linings.

Note: Some automatic car washes may cause damage to the finish on your wheel rims and covers.

Alloy wheels and wheel covers are coated with a clear coat paint finish. To maintain their condition we recommend that you:

- Clean them weekly with the recommended wheel and tire cleaner.
- Use a sponge to remove heavy deposits of dirt and brake dust accumulation.
- Rinse them thoroughly with a pressurized stream of water when you have completed the cleaning process.

We recommend that you use Ford service wheel cleaner. Make sure that you read and follow the manufacturer's instructions.

Using other non-recommended cleaning products can result in severe and permanent cosmetic damage.

Wheels and Tires

GENERAL INFORMATION

A decal with tire pressure data is located in the driver's door opening.

Check and set the tire pressure at the ambient temperature in which you are intending to drive your vehicle and when the tires are cold.

Note: Check your tire pressures regularly to optimize fuel economy.

Note: Use only approved wheel and tire sizes. Using other sizes could damage your vehicle and will make the National Type Approval invalid.

Note: If you change the diameter of the tires from that fitted at the factory, the speedometer may not display the correct speed. Take your vehicle to an authorized dealer to have the engine management system reprogrammed.

Note: If you intend to change the size of the wheels from that fitted at the factory, check the suitability with an authorized dealer.

TEMPORARY MOBILITY KIT

Your vehicle may not have a spare tire. Therefore you will have a temporary mobility kit which will only repair one damaged tire.

The kit is located in the left-hand side of the rear luggage compartment.

General Information

WARNINGS

 Depending on the type and extent of tire damage, some tires can only be partially sealed or not sealed at all. Loss of tire pressure can affect vehicle handling, leading to loss of vehicle control.

WARNINGS

 Do not use the kit on a previously damaged tire, for example when it has been driven under inflated. This could cause loss of vehicle control, personal injury or death.

 Do not use the kit on run flat tires. This could cause loss of vehicle control.

 Do not try to seal damage to the tire sidewall. The tire could burst and cause loss of vehicle control, personal injury or death.

The kit seals most tire punctures with a diameter of up to ¼ inch (six millimeters). This is to temporarily restore mobility.

You must observe the following rules when using the kit:

- Drive with caution and avoid making sudden steering or driving maneuvers, especially if your vehicle is heavily loaded or you are towing a trailer.
- The kit will provide you with an emergency temporary repair, enabling you to continue your journey to the next vehicle or tire dealer, or to drive a maximum distance of 125 miles (200 kilometers).
- Do not exceed a maximum speed of 50 mph (80 km/h).
- Keep the kit out of the reach of children.
- Only use the kit when the ambient temperature is between -40°F (-40°C) and +158°F (+70°C).

Using the Kit

WARNINGS

 Compressed air can act as an explosive or propellant which could cause serious personal injury.

Wheels and Tires

WARNINGS

 Never leave the kit unattended while in use.

 Do not keep the compressor operating for more than 10 minutes. This could cause loss of vehicle control or personal injury.

Note: *You must only use the kit for the vehicle with which it was supplied.*

- Park your vehicle at the roadside so that you do not obstruct the flow of traffic and so that you are able to use the kit without being in danger.
- Apply the parking brake, even if you have parked on a level road, to make sure that your vehicle will not move.
- Do not attempt to remove foreign objects like nails or screws penetrating the tire.
- Leave the engine running while the kit is in use, but not if your vehicle is in an enclosed or poorly ventilated area (for example inside a building). In these circumstances, switch the compressor on with the engine switched off.
- You must replace the sealant bottle with a new one before the expiry date (see top of bottle).
- Inform all other users of your vehicle that the tire has been temporarily sealed with the kit. Make them aware of the special driving conditions that must be observed.

Inflating the Tire

WARNINGS

 Check the sidewall of the tire prior to inflation. If there are any cracks, bumps or similar damage, do not attempt to inflate the tire. This could cause personal injury.

WARNINGS

 Do not stand directly beside the tire while the compressor is operating. This could cause personal injury if the tire bursts.

 Watch the sidewall of the tire. If any cracks, bumps or similar damage appears, switch the compressor off and let the air out by means of the pressure relief valve F. Do not continue driving with this tire. This could cause loss of vehicle control.

 The sealant contains natural rubber latex. Avoid contact with skin and clothing. If this happens, rinse the affected areas immediately with plenty of water and consult a physician.

 If the tire inflation pressure does not reach 1.8 bar (26 psi) within 10 minutes, the tire may have suffered excessive damage, making a temporary repair impossible. In this case, do not continue driving with this tire. This could cause loss of vehicle control.

 Screwing the bottle onto the bottle holder will pierce the seal of the bottle. Do not unscrew the bottle from the holder as the sealant will escape, which could cause serious personal injury.

Wheels and Tires

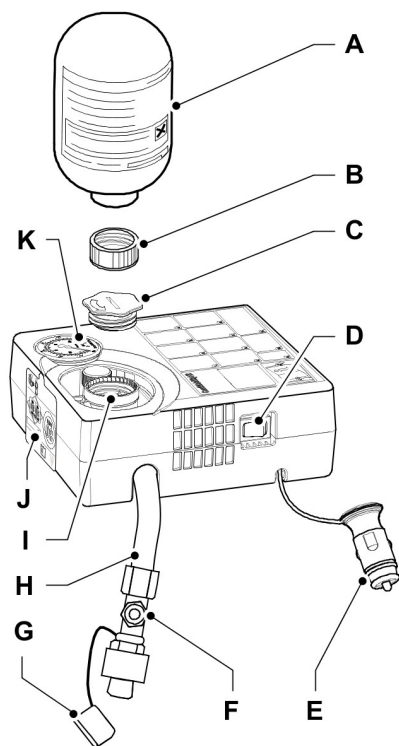

E168569

- A Sealant bottle
- B Bottle lid
- C Orange cap
- D Compressor switch
- E Power plug with cable
- F Pressure relief valve
- G Protective cap
- H Hose
- I Bottle holder

- J Label
- K Pressure gauge

1. Peel off the label J showing the maximum permissible speed of 50 mph (80 km/h) from the casing and attach it to the instrument panel in the driver's field of view. Make sure the label does not obscure anything important.
2. Take the hose H and the power plug with cable E out of the kit.
3. Unscrew the orange cap C and the bottle lid B.
4. Screw the sealant bottle A clockwise into the bottle holder I fully tight.
5. Remove the valve cap from the damaged tire.
6. Detach the protective cap G from the hose H and screw the hose H firmly onto the valve of the damaged tire.
7. Make sure that the compressor switch D is in position 0 and the pressure relief valve F is closed.
8. Insert the power plug E into the cigar lighter socket or auxiliary power point. See **Cigar Lighter** (page 95). See **Auxiliary Power Points** (page 95).
9. Start the engine.
10. Move the compressor switch D to position 1.
11. Inflate the tire for no longer than 10 minutes to an inflation pressure of minimum 1.8 bar (26 psi) and a maximum of 3.5 bar (51 psi). Move the compressor switch D to position 0 and check the current tire pressure with pressure gauge K.

Note: When pumping in the sealant through the tire valve, the pressure may rise up to 6 bar (87 psi) but will drop again after about 30 seconds.

Wheels and Tires

Note: After you have switched the compressor off, you may hear air escaping from the damaged tire. This is normal and can be ignored provided that the specified minimum tire pressure has been reached.

12. Remove the power plug E from the cigar lighter socket or auxiliary power point.
13. Quickly unscrew the hose H from the tire valve and replace the protective cap G. Fasten the valve cap again.

Note: Some residual sealant fluid may drip or spray out of hose H while you are disconnecting it. This is normal.

14. Leave the sealant bottle A in the bottle holder I.
15. Make sure the kit, the bottle lid and the orange cap are stored safely, but still easily accessible in your vehicle. The kit will be required again when you check the tire pressure.
16. Immediately drive approximately two miles (three kilometers) so that the sealant can seal the damaged area.

WARNING



If you experience heavy vibrations, unsteady steering behavior or noises while driving, reduce your speed gradually and stop your vehicle as soon as it is safe to do so. Recheck the tire and its pressure. If the tire pressure is less than 1.3 bar (19 psi) or if there are any cracks, bumps or similar damage visible, do not continue driving with this tire. This could cause loss of vehicle control.

Checking the Tire Pressure

WARNING



Before driving, make sure the tire is adjusted to the recommended inflation pressure. See **Technical Specifications** (page 197). Monitor the tire pressure until the sealed tire is replaced.

1. Stop your vehicle after driving approximately two miles (three kilometers). Check, and where necessary, adjust the pressure of the damaged tire.
2. Attach the kit and read the tire pressure from the pressure gauge K.
3. If the pressure of the sealant-filled tire is 1.3 bar (19 psi) or more, adjust it to the specified pressure. See **Technical Specifications** (page 197).
4. Follow the inflation procedure once again to top up the tire.
5. Check the tire pressure again from the pressure gauge K. If the tire pressure is too high, deflate the tire to the specified pressure using the pressure relief valve F.
6. Once you have inflated the tire to its correct tire pressure, move the compressor switch D to position O, remove the power plug E from the socket, unscrew the hose H, fasten the valve cap and replace the protective cap G.
7. Leave the sealant bottle A in the bottle holder I and store the kit away safely in its original location.
8. Drive to the nearest tire specialist to get the damaged tire replaced. Before the tire is removed from the rim, inform your tire dealer that the tire contains sealant. You must renew the sealant bottle A and hose H as soon as possible once used.

Wheels and Tires

Note: Remember that this kit only provides temporary mobility. Regulations concerning tire repair after usage of the kit may differ from country to country. You should consult a tire specialist for advice.

Empty sealant bottles can be disposed of together with normal household waste. Return remains of sealant to an authorized dealer or dispose of it in compliance with local waste disposal regulations.

TIRE CARE

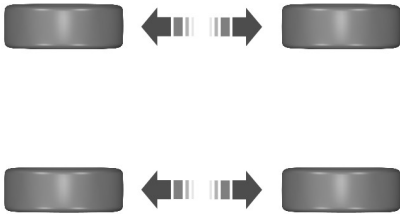

E70415

To make sure the front and rear tires of your vehicle wear evenly and last longer, we recommend that you swap the tires from front to rear and vice versa at regular intervals of between 3000 and 6000 miles (5000 and 10000 kilometers).

WARNING



Do not scrub the sidewalls of the tires when you are parking.

If you have to mount a curb, do so slowly and approach it with the wheels at right-angles to the curb.

Examine the tires regularly for cuts, foreign objects and uneven wear of the tread. Uneven wear could mean that the wheel alignment is outside specification.

Check the tire pressures (including the spare) when cold, every two weeks.

USING WINTER TIRES

WARNING



When you use winter tires on your vehicle, you must make sure that you use the correct lug nuts.

If winter tires are used, you must make sure that you use the correct tire pressures. See **Technical Specifications** (page 197).

USING SNOW CHAINS

WARNINGS



Do not exceed 30 mph (50 km/h).



Do not use snow chains on snow-free roads.



Only fit snow chains to specified tires. See **Technical Specifications** (page 197).



If your vehicle has wheel trims, remove them before fitting snow chains.

Note: The anti-lock braking system will continue to operate normally.

Only use small link snow chains of approximately 10 mm.

Only use snow chains on the front wheels.

Vehicles with Stability Control

When stability control is on, your vehicle may exhibit some unusual driving characteristics. To reduce this, switch traction control off. See **Using Stability Control** (page 122).

Wheels and Tires

TIRE PRESSURE MONITORING SYSTEM

WARNING



The tire pressure monitoring system is not a substitute for manually checking tire pressures. The tire pressure should be checked periodically using a tire gauge, see **When Inflating the Tires** in this chapter. Failure to correctly maintain tire pressures could increase the risk of tire failure, loss of control, vehicle rollover and personal injury.



You must check the tire pressures (including the spare tire where applicable) every two weeks when the tires are cold. Tires must be inflated to the correct pressure. See **Wheels and Tires** (page 184). The tire pressures are also on the tire inflation pressure label (located on the edge of driver door or the B-Pillar).

As a driver assistance feature, your vehicle has a tire pressure monitoring system. A warning lamp will illuminate when one or more of the tires are significantly under-inflated. If the low tire pressure warning lamp illuminates, you should stop your vehicle as soon as it is safe to do so, check the tires and inflate them to the correct pressure.

Driving on under-inflated tires can:

- Cause them to overheat.
- Lead to tire failure.
- Reduce fuel efficiency.
- Reduce tire life.
- Affect vehicle handling or stopping ability.

The system is not a substitute for correct tire maintenance. Correct tire pressures must be maintained, even if under-inflation has not illuminated the warning lamp.

Your vehicle has a system malfunction indicator to indicate when the system is not operating correctly. The malfunction indicator and low tire pressure warning lamp are combined. When the system detects a malfunction, the warning lamp will flash for approximately one minute and then remain illuminated. This sequence will occur every time you switch the ignition on while the malfunction remains. Have your vehicle checked by an authorized dealer as soon as possible.

When the malfunction indicator is illuminated, the system may not be able to detect or signal low tire pressures. A malfunction may occur for a variety of reasons, including the installation of a replacement tire or wheel that prevents the system from functioning correctly. Always check the tire pressure monitoring system malfunction warning after replacing one or more tires or wheels on your vehicle. Make sure the replacement tires or wheels allow the system to continue to function correctly.

Changing Tires With a Tire Pressure Monitoring System



E142549

Wheels and Tires

Note: Each road wheel and tire is equipped with a tire pressure sensor located inside the wheel and tire assembly cavity. The pressure sensor is attached to the valve stem. The pressure sensor is covered by the tire and is not visible unless the tire is removed. Take care when changing the tire to avoid damaging the sensor. Failure to correctly maintain tire pressures could increase the risk of tire failure, loss of control, vehicle rollover and personal injury.

You should always have tires serviced by an authorized dealer.

Understanding the Tire Pressure Monitoring System

The system measures the pressure in the four road tires and sends the tire pressure readings to your vehicle. The low tire pressure warning lamp will illuminate if any of the tire pressures are significantly low. If the warning lamp is on you must inflate one or more of the tires to the correct pressure.

When the Temporary Spare Tire is Installed

If a road wheel and tire needs to be replaced with the temporary spare wheel, the system will continue to identify a defect. This is to remind you that the damaged road wheel and tire must be repaired and refitted to your vehicle.

To restore the correct operation of the system, you must have the repaired road wheel and tire assembly refitted to your vehicle. For additional information, see **Changing Tires with a Tire Pressure Monitoring System** in this section.

When You Believe the System is Not Operating Correctly

The main function of the system is to warn you when the tire pressures are low. It can also warn you in the event the system is no longer capable of operating correctly. See the following chart for information concerning the system:

Low tire pressure warning lamp	Possible cause	Action required
Solid warning lamp	Tire(s) under-inflated	1. Make sure tires are at the correct pressure. See When Inflating the Tires in this chapter. 2. After inflating the tires to the correct pressure. See Wheels and Tires (page 184). The tire pressures are also on the tire inflation pressure label (located on the edge of driver door or the B-Pillar).
	Spare tire in use	Repair the damaged road wheel and tire assembly and refit it to your vehicle to restore correct system function. For a description on how the system functions, see When the Temporary Spare Tire is Installed in this section.

Wheels and Tires

Low tire pressure warning lamp	Possible cause	Action required
	Tire pressure monitoring system malfunction	If the tires are correctly inflated and the spare tire is not in use but the light remains on, have your vehicle checked by an authorized dealer as soon as possible.
Flashing warning lamp	Spare tire in use	Repair the damaged road wheel and tire assembly and refit it to your vehicle to restore correct system function. For a description on how the system functions, see When the Temporary Spare Tire is Installed in this section.
	Tire pressure monitoring system malfunction	If the tires are correctly inflated and the spare tire is not in use but the light remains on, have your vehicle checked by an authorized dealer as soon as possible.

Tire Pressure Monitoring System Reset Procedure

Overview

The system reset procedure must be carried out after each tire replacement or adjustment of the tire pressures.

To maintain your vehicle load carrying capability, your vehicle requires different tire pressures in the front tires compared to the rear tires. The system on your vehicle is designed to illuminate the warning lamp at different pressures for the front and rear tires.

The tires need to be periodically rotated to provide consistent performance and maximum tire life, the system needs to know when the tires have been rotated to determine which set of tires are on the front and rear axles. With this information, the system can detect and correctly warn of low tire pressures.

Carrying Out the System Reset Procedure

1. Switch the ignition on.
2. Using the information display control, navigate to **Menu, Vehicle settings, Driver assist, Tyre Monitor**.
3. Press and hold the **OK** button until confirmation appears.

Alternatively, if your vehicle has a tire pressure monitoring system reset button, press and hold the button until confirmation appears.

How Temperature Affects the Tire Pressures

While driving in a normal manner, tire pressures may increase up to 0.3 bar (4 psi) from a cold start situation. If the vehicle is stationary overnight and the temperature significantly lower than the daytime temperature, tire pressures may

Wheels and Tires

decrease up to 0.2 bar (3 psi) for a drop of 17°C (30°F) in ambient temperature. This lower pressure value will be detected by the system as being significantly lower than the correct inflation pressure and the warning lamp will illuminate.

When Inflating the Tires

When inflating the tires the system may not respond immediately to the air added to the tires.

If the warning lamp is on:

1. Check each tire to verify that none are flat.
2. If one or more tires are flat, repair as necessary.
3. Check the tire pressures and inflate all the tires to the correct pressure.
4. Carry out the tire pressure monitoring system reset procedure.

CHANGING A ROAD WHEEL

Lug Nuts

You can obtain a replacement locking lug nut key and replacement locking lug nuts from an authorized dealer using the reference number certificate.

Vehicles with a Spare Wheel

If the spare wheel is exactly the same type and size as the other fitted road wheels, you can replace the existing road wheel with the spare wheel and continue to drive in the normal manner.

If the spare wheel is different to the other road wheels, it will carry a yellow label with the appropriate speed limit.

Refer to the following information before changing the road wheel.



WARNINGS

-  Drive the shortest possible distances.
-  Do not fit more than one spare wheel on your vehicle at any one time.
-  Do not carry out any tire repairs on a spare wheel.
-  Do not drive through an automatic car wash.
-  If you are unsure what type of spare wheel you have do not exceed 50 mph (80 km/h).
-  Only fit snow chains to specified tires. See **Technical Specifications** (page 197).
-  The ground clearance of your vehicle may be reduced. Take care when parking next to a curb.

Note: *Your vehicle may exhibit some unusual driving characteristics.*

Vehicle Jack

WARNINGS

-  The vehicle jack supplied with your vehicle should only be used when changing a wheel in emergency situations.
-  Before using the vehicle jack, check that it is not damaged or deformed and that the thread is lubricated and free from foreign matter.
-  Never place anything between the jack and the ground, or the jack and your vehicle.

Note: *Vehicles with a temporary mobility kit do not have a vehicle jack or a wheel brace.*

Wheels and Tires

It is recommended to use a workshop type hydraulic jack for changing between summer and winter tires.

Note: Use a jack with a minimum lifting capacity of 1.5 tonnes and a lifting plate with a minimum diameter of approximately 3 inches (76 millimeters).

Vehicles without a Temporary Mobility Kit

Your vehicle jack and wheel brace are located in the left-hand side of the luggage compartment.

Jacking and Lifting Points

WARNING



Use only the specified jacking points. If you use other positions, you may damage the body, steering, suspension, engine, braking system or the fuel lines.

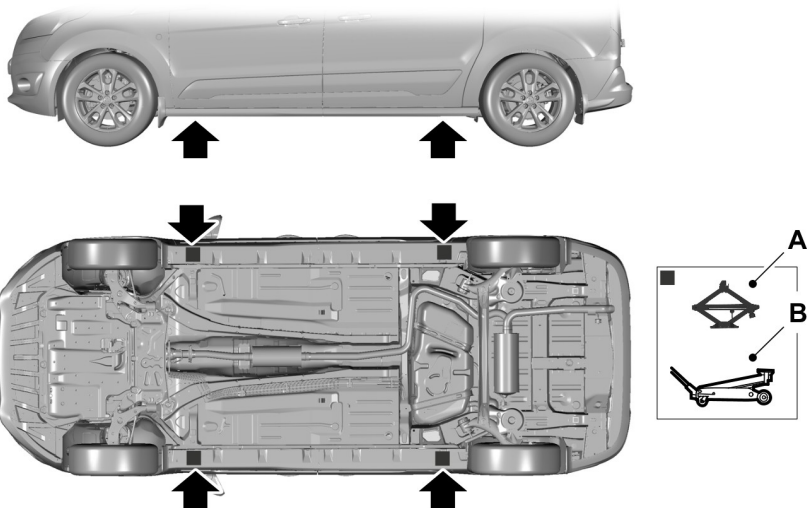

E164258

- A Emergency use only
- B Maintenance

Wheels and Tires

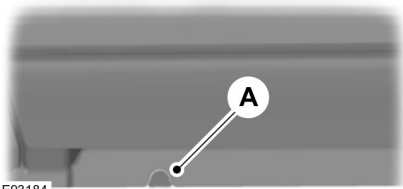

E93184

Indentations in the sills show the location of the jacking points.



E142553

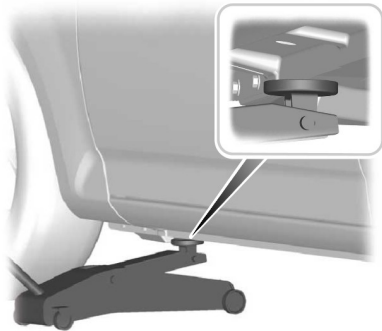

E93020

Note: You can use the wheel brace to raise and lower the jack.

Lowering the Spare Wheel

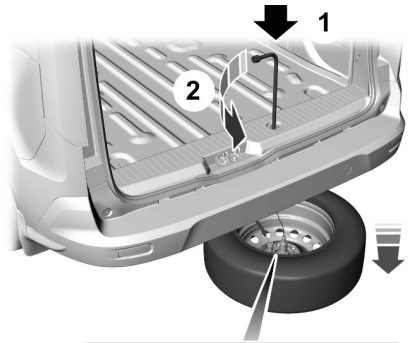

E166659

1. Insert the hexagonal end of the wheel brace into the guide hole.
2. Turn the wheel brace counterclockwise until the spare wheel rests on the ground and there is slack in the cable.
3. Unscrew the cap and slide it back, turn the nipple of the cable through 90 degrees to remove the first cable.
4. Unscrew the nut to remove the second cable.

Wheels and Tires

Removing the Wheel Trim

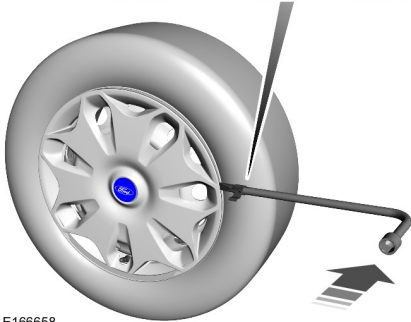
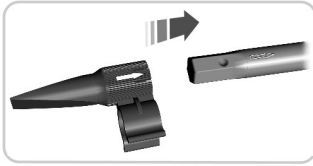





E166658

1. Insert the wheel brace and carefully remove the wheel trim.





Note: Make sure that you pull the wheel trim remover at right angles to the trim.

Removing a Road Wheel

WARNINGS

-  Park your vehicle in such a position that neither the traffic nor you are hindered or endangered.
-  Set up a warning triangle.
-  Make sure that your vehicle is on firm, level ground with the wheels pointing straight ahead.
-  Switch the ignition off and apply the parking brake.
-  If your vehicle has a manual transmission, select first or reverse gear. If it has an automatic transmission, select park.

WARNINGS

-  Have the passengers leave your vehicle.
-  Secure the diagonally opposite wheel with an appropriate block or wheel chock.
-  Do not work underneath your vehicle when it is supported only by a jack.
-  Make sure that the jack is vertical to the jacking point and the base is flat on the ground.

Note: The spare wheel is located under the floor cover in the luggage compartment.

1. Install the locking lug nut key.

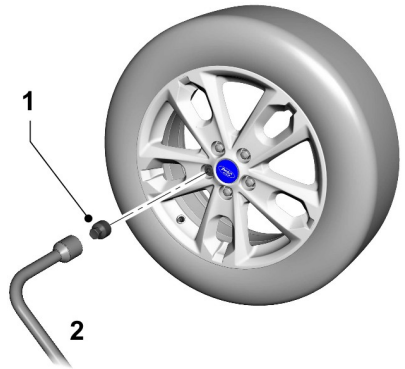

E166675

2. Slacken the lug nuts.
3. Jack up your vehicle until the tire is clear of the ground.
4. Remove the lug nuts and the wheel.

Note: Do not lay alloy wheels face down on the ground, this will damage the paint.

Wheels and Tires

Installing a Road Wheel

WARNINGS

 Make sure that the arrows on directional tires point in the direction of rotation when your vehicle is moving forward. If you have to fit a spare wheel with the arrows pointing in the opposite direction, have the tire refitted in the correct direction by an authorized dealer.

 Use only approved wheel and tire sizes. Using other sizes could damage your vehicle and will make the National Type Approval invalid. See **Technical Specifications** (page 197).

 Do not fit run flat tires on vehicles that were not originally fitted with them. See an authorized dealer for more details about compatibility.

WARNINGS

 Do not install alloy wheels using lug nuts designed for use with steel wheels.

 Lug nuts are subject to change. You must make sure that you use only the specific lug nuts and wheels supplied for your vehicle. If in doubt see an authorized dealer.

 Make sure there is no lubrication (grease or oil) on the threads or the surface between the wheel lugs and nuts. This can cause the lug nuts to loosen while driving.

Note: *The lug nuts of alloy wheels can also be used for the steel spare wheel for a short time (maximum two weeks).*

Note: *Make sure the wheel and hub contact surfaces are free from foreign matter.*

Note: *Make sure that the cones on the lug nuts are against the wheel.*

1. Install the wheel.
2. Install the lug nuts finger tight.
3. Install the locking lug nut key.

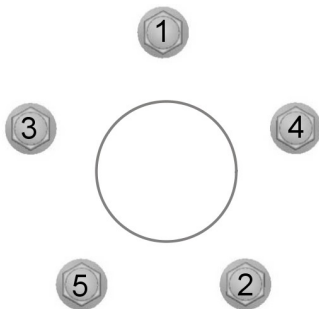

E154985

4. Partially tighten the lug nuts in the sequence shown.
5. Lower your vehicle and remove the jack.
6. Fully tighten the lug nuts in the sequence shown. See **Technical Specifications** (page 197).
7. Install the wheel trim using the ball of your hand.

WARNING

 Have the lug nuts checked for tightness and the tire pressure checked as soon as possible.

Stowing the Flat Tire

Do not raise the spare wheel carrier without the wheel attached. Damage can occur to the winch mechanism if lowered without a wheel attached.

Note: *Do not lay alloy wheels face down on the ground, this will damage the paint. When stowing the flat tire use a sheet or mat under the wheel to protect the paint.*

Wheels and Tires

TECHNICAL SPECIFICATIONS - VEHICLES WITH: SHORT WHEELBASE KOMBI

Lug Nut Torque

Wheel type	lbf.ft (Nm)
All	100 lbf.ft (135 Nm)

Tire Pressures (Cold Tires)

Tire size	Variant	Normal load		Full load	
		Front	Rear	Front	Rear
		psi (bar)	psi (bar)	psi (bar)	psi (bar)
205/60 R16* and 215/55 R16*	530kg and 550kg	33 psi (2.3 bar)	30 psi (2.1 bar)	36 psi (2.5 bar)	42 psi (2.9 bar)
205/60 R16* and 215/55 R16*	725kg	33 psi (2.3 bar)	33 psi (2.3 bar)	36 psi (2.5 bar)	49 psi (3.4 bar)
205/55 R17	530kg and 550kg	33 psi (2.3 bar)	33 psi (2.3 bar)	36 psi (2.5 bar)	42 psi (2.9 bar)

*Only fit snow chains to specified tires.

TECHNICAL SPECIFICATIONS - VEHICLES WITH: LONG WHEELBASE KOMBI

Lug Nut Torque

Wheel type	lbf.ft (Nm)
All	100 lbf.ft (135 Nm)

Wheels and Tires

Tire Pressures (Cold Tires)

Tire size	Normal load		Full load	
	Front	Rear	Front	Rear
	psi (bar)	psi (bar)	psi (bar)	psi (bar)
205/60 R16* and 215/55 R16*	35 psi (2.4 bar)	35 psi (2.4 bar)	38 psi (2.6 bar)	49 psi (3.4 bar)
205/55 R17	35 psi (2.4 bar)	36 psi (2.5 bar)	39 psi (2.7 bar)	45 psi (3.1 bar)

*Only fit snow chains to specified tires.

TECHNICAL SPECIFICATIONS - VEHICLES WITH: SHORT WHEELBASE VAN

Lug Nut Torque

Wheel type	lb.ft (Nm)
All	100 lb.ft (135 Nm)

Tire Pressures (Cold Tires)

Tire size	Normal load		Full load	
	Front	Rear	Front	Rear
	psi (bar)	psi (bar)	psi (bar)	psi (bar)
205/60 R16* and 215/55 R16*	33 psi (2.3 bar)	30 psi (2.1 bar)	39 psi (2.7 bar)	46 psi (3.2 bar)

*Only fit snow chains to specified tires.

Wheels and Tires

TECHNICAL SPECIFICATIONS - VEHICLES WITH: LONG WHEELBASE VAN

Lug Nut Torque

Wheel type	lbf.ft (Nm)
All	100 lbf.ft (135 Nm)

Tire Pressures (Cold Tires)

Tire size	Normal load		Full load	
	Front	Rear	Front	Rear
	psi (bar)	psi (bar)	psi (bar)	psi (bar)
205/60 R16* and 215/55 R16*	35 psi (2.4 bar)	35 psi (2.4 bar)	38 psi (2.6 bar)	49 psi (3.4 bar)

*Only fit snow chains to specified tires.

TECHNICAL SPECIFICATIONS - VEHICLES WITH: SHORT WHEELBASE DOUBLE CAB IN VAN

Lug Nut Torque

Wheel type	lbf.ft (Nm)
All	100 lbf.ft (135 Nm)

Tire Pressures (Cold Tires)

Tire size	Normal load		Full load	
	Front	Rear	Front	Rear
	psi (bar)	psi (bar)	psi (bar)	psi (bar)
205/60 R16* and 215/55 R16*	33 psi (2.3 bar)	30 psi (2.1 bar)	36 psi (2.5 bar)	49 psi (3.4 bar)

*Only fit snow chains to specified tires.

Wheels and Tires

TECHNICAL SPECIFICATIONS - VEHICLES WITH: LONG WHEELBASE DOUBLE CAB IN VAN

Lug Nut Torque

Wheel type	lbf.ft (Nm)
All	100 lbf.ft (135 Nm)

Tire Pressures (Cold Tires)

Tire size	Normal load		Full load	
	Front	Rear	Front	Rear
	psi (bar)	psi (bar)	psi (bar)	psi (bar)
205/60 R16* and 215/55 R16*	35 psi (2.4 bar)	35 psi (2.4 bar)	38 psi (2.6 bar)	49 psi (3.4 bar)

*Only fit snow chains to specified tires.

Capacities and Specifications

VEHICLE DIMENSIONS - VEHICLES WITH: LONG WHEELBASE KOMBI

Vehicle Dimensions

Dimension description	in (mm)
Maximum length	189.7 in (4,818 mm)
Overall width including exterior mirrors	84.1 in (2,137 mm)
Overall height - EC curb weight	72.6 in (1,845 mm)
Wheelbase	120.6 in (3,062 mm)
Front track	61.7 in (1,568 mm)
Rear track	62.4 in (1,584 mm)

VEHICLE DIMENSIONS - VEHICLES WITH: LONG WHEELBASE DOUBLE CAB IN VAN/LONG WHEELBASE VAN

Vehicle Dimensions

Dimension description	in (mm)
Maximum length	189.7 in (4,818 mm)
Overall width including exterior mirrors	84.1 in (2,137 mm)
Overall height - EC curb weight	73.3 in (1,862 mm)
Wheelbase	120.6 in (3,062 mm)
Front track	61.7 in (1,568 mm)
Rear track	62.4 in (1,585 mm)

Capacities and Specifications

VEHICLE DIMENSIONS - VEHICLES WITH: SHORT WHEELBASE KOMBI

Vehicle Dimensions

Dimension description	in (mm)
Maximum length	173.9 in (4,418 mm)
Overall width including exterior mirrors	84.1 in (2,137 mm)
Overall height - EC curb weight	72.9 in (1,852 mm)
Wheelbase	104.8 in (2,662 mm)
Front track	61.7 in (1,568 mm)
Rear track	62.4 in (1,584 mm)

VEHICLE DIMENSIONS - VEHICLES WITH: SHORT WHEELBASE DOUBLE CAB IN VAN/SHORT WHEELBASE VAN

Vehicle Dimensions

Dimension description	in (mm)
Maximum length	173.9 in (4,418 mm)
Overall width including exterior mirrors	84.1 in (2,137 mm)
Overall height - EC curb weight	73.3 in (1,861 mm)
Wheelbase	104.8 in (2,662 mm)
Front track	61.7 in (1,568 mm)
Rear track	62.4 in (1,585 mm)

Capacities and Specifications

TOWBAR DIMENSIONS

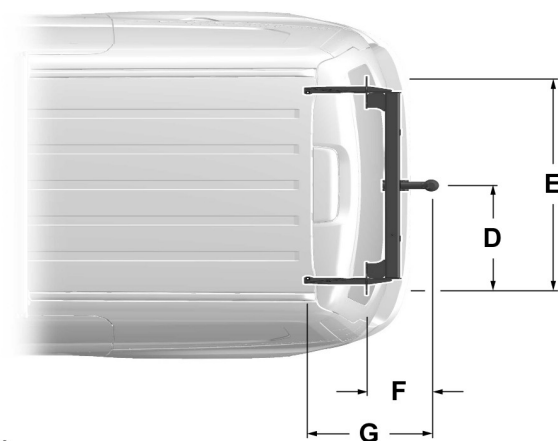
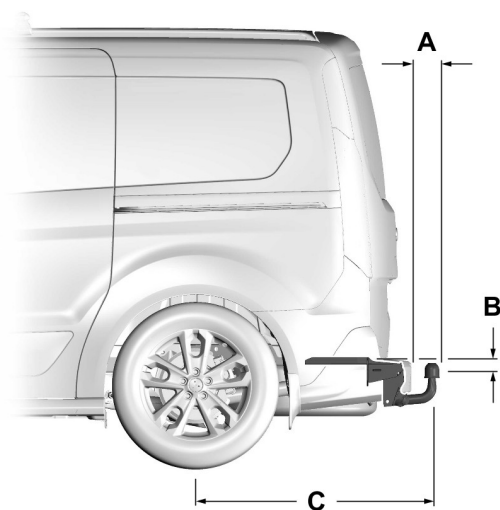

E163459

Capacities and Specifications

Item	Dimension description	in (mm)
A	Bumper to end of tow ball	4.4 in (113 mm)
B	Attachment point to center of tow ball	0.8 in (21 mm)
C	Wheel center to center of tow ball	37.9 in (963 mm)
D	Center of tow ball to side member	19.4 in (493 mm)
E	Distance between side members	38.8 in (986 mm)
F	Center of tow ball to center of attachment point one	10.6 in (268 mm)
G	Center of tow ball to center of attachment point two	19.9 in (505 mm)

Maximum Permissible Nose Weight

lb (kg)
165 lb (75 kg)

Note: The information shown on the vehicle identification plate is dependent upon market requirements.

VEHICLE IDENTIFICATION PLATE

Note: Your vehicle identification plate design may vary to that shown.

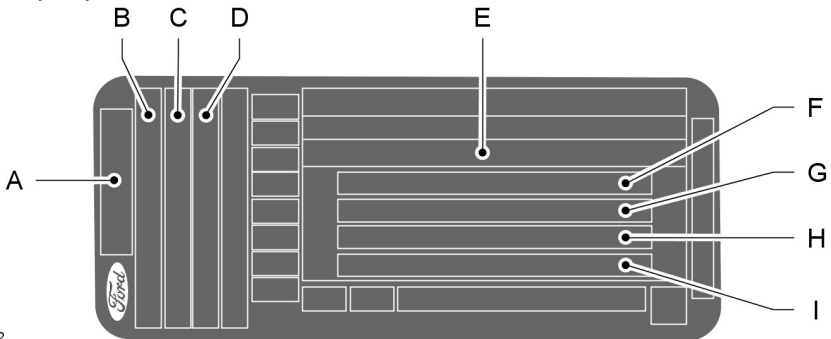

E135662

- A Model
- B Variant

Capacities and Specifications

- C Engine designation
- D Engine power and emission level
- E Vehicle identification number
- F Gross vehicle weight
- G Gross train weight
- H Maximum front axle weight
- I Maximum rear axle weight

Your vehicle identification number and maximum weights are shown on a plate, located at the bottom of the lock side of the right-hand door aperture.

VEHICLE IDENTIFICATION NUMBER

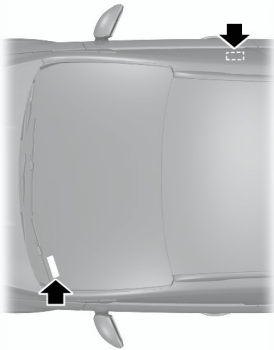

E87496

The vehicle identification number is stamped into the floor panel on the right-hand side, beside the front seat. It is also shown on the left-hand side of the instrument panel.

Audio System

GENERAL INFORMATION

Radio Frequencies and Reception Factors

Radio reception factors	
Distance and Strength	The further you travel away from an FM station, the weaker the signal and the weaker the reception.
Terrain	Hills, mountains, tall buildings, bridges, tunnels, freeway overpasses, parking garages, dense tree foliage and thunderstorms can interfere with the reception.
Station overload	When you pass near a radio transmission tower, a stronger signal can override a weaker signal and can cause interference in the audio system.

CD and CD Player Information

Note: *CD units play commercially pressed 4.75-inch (12 centimeter) audio compact discs only. Due to technical incompatibility, certain recordable and re-recordable compact discs may not function correctly when used in Ford CD players.*

Note: *Do not insert CDs with homemade paper (adhesive) labels into the CD player as the label may peel and cause the CD to become jammed. You should use a permanent felt tip marker rather than adhesive labels on your homemade CDs. Ballpoint pens may damage CDs. Please contact an authorized dealer for further information.*

Note: *Do not use any irregularly shaped discs or discs with a scratch protection film attached.*

Always handle discs by their edges only. Clean the disc with an approved CD cleaner only. Wipe it from the center of the disc toward the edge. Do not clean in a circular motion.

Do not expose discs to direct sunlight or heat sources for extended periods.

MP3 and WMA Track and Folder Structure

Audio systems capable of recognizing and playing MP3 and WMA individual tracks and folder structures work as follows:

- There are two different modes for MP3 and WMA disc playback: MP3 and WMA track mode (system default) and MP3 and WMA folder mode.
- MP3 and WMA track mode ignores any folder structure on the MP3 and WMA disc. The player numbers each MP3 and WMA track on the disc (noted by the .mp3 or .WMA file extension) from T001 to a maximum of T255. The maximum number of playable MP3 and WMA files may be less depending on the structure of the CD and exact model of radio present.

Audio System

- MP3 and WMA folder mode represents a folder structure consisting of one level of folders. The CD player numbers all MP3 and WMA tracks on the disc (noted by the .mp3 or .WMA file extension) and all folders containing MP3 and WMA files, from F001 (folder) T001 (track) to F253 T255.
- Creating discs with only one level of folders helps with navigation through the disc files.

If you are burning your own MP3 and WMA discs, it is important to understand how the system reads the structures you create. While various files may be present, (files with extensions other than mp3 and WMA), only files with the .mp3 and WMA extension are played; other files are ignored by the system. This enables you to use the same MP3 and WMA disc for a variety of tasks on your work computer, home computer and your in-vehicle system.

In track mode, the system displays and plays the structure as if it were only one level deep (all .mp3 files play, regardless of being in a specific folder). In folder mode, the system only plays the .mp3 files in the current folder.

AUDIO UNIT - VEHICLES WITH: AM/FM/CD/DIGITAL AUDIO BROADCAST (DAB) RADIO/SYNC

WARNING



Driving while distracted can result in loss of vehicle control, crash and injury. We strongly recommend that you use extreme caution when using any device that may take your focus off the road. Your primary responsibility is the safe operation of your vehicle. We recommend against the use of any handheld device while driving and encourage the use of voice-operated systems when possible. Make sure you are aware of all applicable local laws that may affect the use of electronic devices while driving.

Audio System

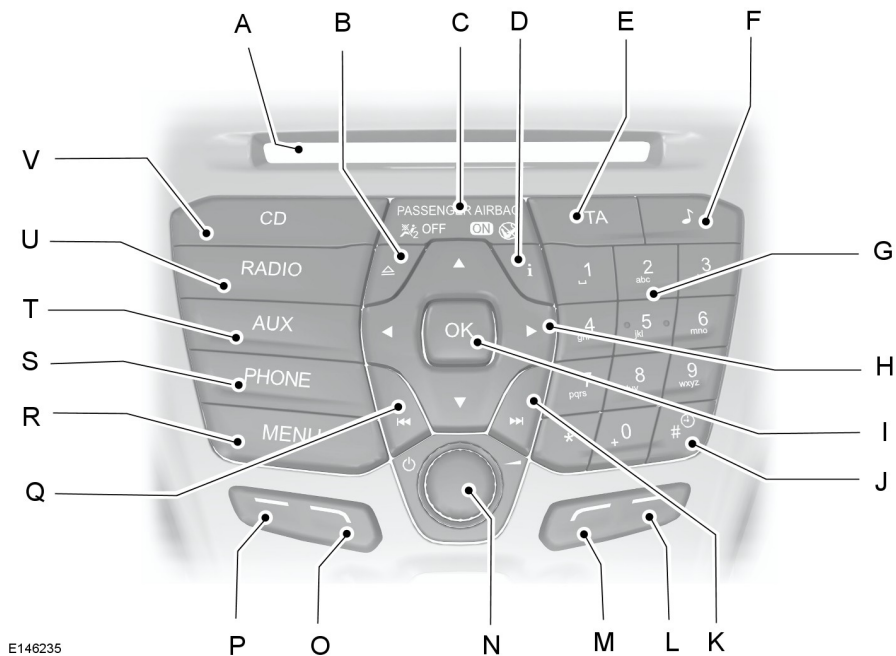

E146235

- A **CD slot:** Where you insert a CD.
- B **Eject:** Press the button to eject a CD.
- C **Passenger airbag information:** Informs you when the passenger airbag is either on or off.
- D **INFO:** Press the button to access radio, CD, USB and iPod information.
- E **TA:** Press the button to turn traffic announcements on or off and cancel announcements during an active announcement.
- F **SOUND:** Press the button to adjust the sound settings for bass, treble, middle, balance and fade.
- G **Numeric keypad:** Press the button to recall a previously stored station. To store a favorite station press and hold until the sound returns.
- H **Cursor arrows:** Press a button to scroll through on-screen choices.
- I **OK:** Press the button to confirm on-screen selections.
- J **Clock:** Press the button to select clock setup.

Audio System

- K **Seek up:** Press the button to go to the next station up the radio frequency band or the next track on a CD.
- L **Function button 4:** Press the button to select different functions of the audio system depending on which mode (i.e. radio or CD) you are in.
- M **Function button 3:** Press the button to select different functions of the audio system depending on which mode (i.e. radio or CD) you are in.
- N **On, Off and Volume:** Press the button to switch the audio system on or off. Turn the dial to adjust the volume.
- O **Function button 2:** Press the button to select different functions of the audio system depending on which mode (i.e. radio or CD) you are in.
- P **Function button 1:** Press the button to select different functions of the audio system depending on which mode (i.e. radio or CD) you are in.
- Q **Seek down:** Press the button to go to the next station down the radio frequency band or the previous track on a CD.
- R **MENU:** Press the button to access different audio system features.
- S **PHONE:** Press the button to access the phone feature of the SYNC system by pressing **PHONE** then **MENU**.
- T **AUX:** Press the button to access the AUX and SYNC features, it will also cancel the menu or list browsing.
- U **RADIO:** Press the button to select different radio bands, it will also cancel the menu or list browsing.
- V **CD:** Press the button to change source to CD, it will also cancel the menu or list browsing.

Sound Button

This will allow you to adjust the sound settings (for example bass, middle and treble).

1. Press the sound button.
2. Use the up and down arrow buttons to select the required setting.
3. Use the left and right arrow buttons to make the necessary adjustment. The display indicates the level selected.
4. Press the **OK** button to confirm the new settings.

Waveband Button

Press the **RADIO** button to select from the wavebands available.

You can use the selector to return to radio reception when you have been listening to another source.

Alternatively, press the left arrow button to display the available wavebands. Scroll to the required waveband and press **OK**.

Audio System

Station Tuning Control

Seek Tuning

Select a waveband and briefly press one of the seek buttons. The unit will stop at the first station it finds in the direction you have chosen.

Manual Tuning

1. Press function button 2.
2. Use the left and right arrow buttons to tune down or up the waveband in small increments or press and hold to increment quickly, until you find a station you want to listen to.
3. Press **OK** to continue listening to a station.

Scan Tuning

Scan allows you to listen to a few seconds of each station detected.

1. Press function button 3.
2. Use the seek buttons to scan up or down the selected waveband.
3. Press function button 3 again or **OK** to continue listening to a station.

Station Preset Buttons

This feature allows you to store your favorite stations, they can be recalled by selecting the appropriate waveband and pressing one of the preset buttons.

1. Select a waveband.
2. Tune to the station required.
3. Press and hold one of the preset buttons. A progress bar and message will appear. When the progress bar completes the station has been stored. The audio unit will also mute momentarily as confirmation.

You can repeat this on each waveband and for each preset button.

Note: *When you drive to another part of the country, stations that broadcast on alternative frequencies, and are stored on preset buttons, may be updated with the correct frequency and station name for that area.*

Autostore Control

Note: *This will store up to a maximum of the 10 strongest signals available, either from the AM or the FM waveband, and overwrite the previously stored stations. You can also store stations manually in the same way as other wavebands.*

- Press the **MENU** button, select audio mode then press and hold the **RADIO** button.
- When the search is complete, sound is restored and the strongest signals are stored on the autostore presets.

Traffic Information Control

Many stations that broadcast on the FM waveband have a TP code to signify that they carry traffic program information.

Turning Traffic Announcements On and Off

Before you can receive traffic announcements, you must press either the **TA** or **TRAFFIC** button. A TA display will appear to show the feature is switched on.

If you are already tuned to a station that broadcasts traffic information, TP will also be displayed. Otherwise the unit will search for a traffic program.

When traffic information is broadcast, it will automatically interrupt normal radio or CD playback and Traffic Announcement will appear in the display.

If a non-traffic station is selected or recalled using a preset button, the audio unit will remain on that station unless **TA** or **TRAFFIC** is turned off, then on again.

Audio System

Note: If traffic announcement is on and you select a preset or manual tune to a non traffic announcement station no traffic announcement will be heard.

Note: When you are listening to a non traffic announcement station and turn traffic announcement off and on again a TP seek will occur.

Traffic Announcement Volume

Traffic announcements interrupt normal broadcasts at a preset minimum level that is usually louder than normal listening volumes.

To adjust the preset volume:

- Use the volume control to make the necessary adjustment during an incoming traffic announcement broadcast. The display will show the level selected.

Ending Traffic Announcements

The audio unit will return to normal operation at the end of each traffic announcement. To end the announcement prematurely, press **TA** or **TRAFFIC** during the announcement.

Note: If you press **TA** or **TRAFFIC** at any other time it will switch all announcements off.

Automatic Volume Control

When available, automatic volume control adjusts the volume level to compensate for engine noise and road speed noise.

1. Press the **MENU** button and select **AUDIO** or **AUDIO SETTINGS**.
2. Select **AVC LEVEL** or **ADAPTIVE VOL**.
3. Use the left or right arrow button to adjust the setting.
4. Press the **OK** button to confirm your selection.

5. Press the **MENU** button to return.

News Broadcasts

Your audio unit may interrupt normal reception to broadcast news bulletins from stations on the FM waveband, radio data system or other enhanced network linked stations.

The display will indicate there is an incoming announcement, during news broadcasts. When the audio unit interrupts for a news broadcast the preset volume level will be the same as traffic announcements.

1. Press the **MENU** button.
2. Select **AUDIO** or **AUDIO SETTINGS**.
3. Scroll to **NEWS** and turn on or off with the **OK** button.
4. Press the **MENU** button to return.

Alternative Frequencies

The majority of programs that broadcast on the FM waveband have a program identification code, it can be recognized by audio units.

When your vehicle moves from one transmission area to another with the alternative frequencies tuning switched on, this function will search for the strongest station signal.

Under certain conditions, however, alternative frequencies tuning may temporarily disrupt normal reception.

When selected, the unit continually evaluates signal strength and, if a better signal becomes available, the unit will switch to that alternative. It mutes while it checks a list of alternative frequencies and if necessary, it will search once across the selected waveband for a genuine alternative frequency.

Audio System

It will restore radio reception when it finds one or if one is not found, the unit will return to the original stored frequency.

When selected, AF may appear in the display.

1. Press the **MENU** button.
2. Select **AUDIO** or **AUDIO SETTINGS**.
3. Scroll to **ALTERNAT FREQ.** or **ALTERNATIVE FREQ.** and turn on or off with the **OK** button.
4. Press the **MENU** button to return.

Regional Mode

Regional mode controls the behavior of alternative frequencies switching between regionally related networks of a parent broadcaster. A broadcaster may run a fairly large network across a large part of the country. At various times of the day this large network may be broken down into a number of smaller regional networks, typically centered on major towns or cities. When the network is not split into regional variants, the whole network carries the same programming.

Regional mode on: This prevents random alternative frequency switches when neighboring regional networks are not carrying the same programming.

Regional mode off: This allows a larger coverage area if neighboring regional networks are carrying the same programming, but can cause random alternative frequency switches if they are not.

1. Press the **MENU** button.
2. Select **AUDIO** or **AUDIO SETTINGS**.
3. Scroll to **RDS REGIONAL** and turn on or off with the **OK** button.
4. Press the **MENU** button to return.

AUDIO UNIT - VEHICLES WITH: DIGITAL AUDIO BROADCAST (DAB) RADIO/NAVIGATION SYSTEM

WARNING

 Driving while distracted can result in loss of vehicle control, crash and injury. We strongly recommend that you use extreme caution when using any device that may take your focus off the road. Your primary responsibility is the safe operation of your vehicle. We recommend against the use of any handheld device while driving and encourage the use of voice-operated systems when possible. Make sure you are aware of all applicable local laws that may affect the use of electronic devices while driving.

Audio System

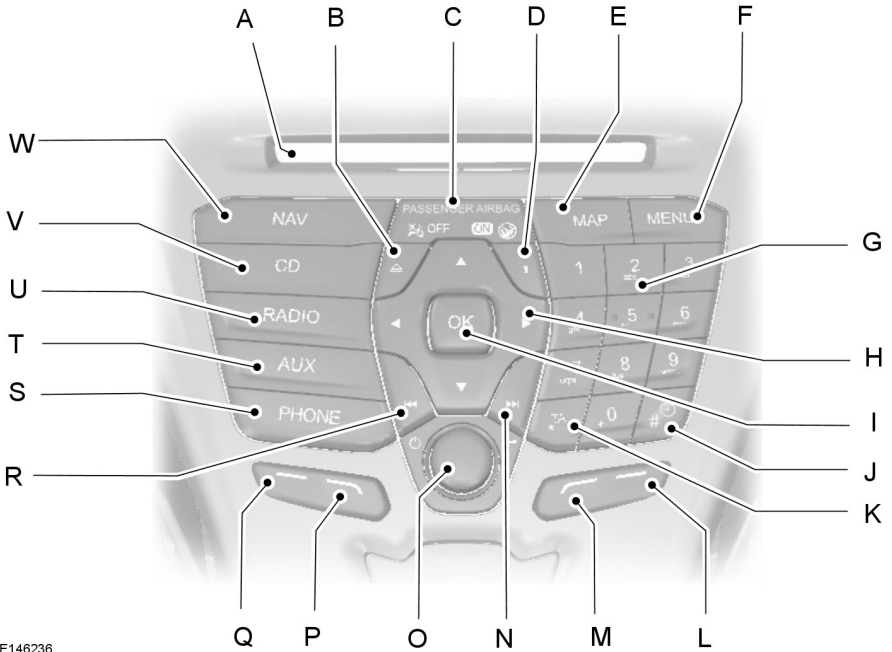

E146236

- A **CD slot:** Where you insert a CD.
- B **Eject:** Press the button to eject a CD.
- C **Passenger airbag information:** Informs you when the passenger airbag is either on or off.
- D **INFO:** Press the button to access radio, CD, USB, iPod and Navigation information. If Navigation has been selected, pressing this button will show details of your current location or journey.
- E **MAP:** Press the button to access map features.
- F **MENU:** Press the button to access different audio system features.
- G **Numeric keypad** Press the button to recall a previously stored station. To store a favorite station press and hold until the sound returns.
- H **Cursor arrows:** Press a button to scroll through on-screen choices.
- I **OK:** Press the button to confirm on-screen selections.

Audio System

- J **Clock:** Press the button to select clock setup.
- K **TA:** Press the button to turn traffic announcements on or off and cancel announcements during an active announcement. If Navigation has been selected pressing this button takes you to the Traffic menu.
- L **Function button 4:** Press the button to select different functions of the audio system depending on which mode (i.e. radio or CD) you are in.
- M **Function button 3:** Press the button to select different functions of the audio system depending on which mode (i.e. radio or CD) you are in.
- N **Seek up:** Press the button to go to the next station up the radio frequency band or the next track on a CD when in CD mode. In phone mode, use the button to end a phone call. An incoming call can be rejected.
- O **On, Off and Volume:** Press the button to switch the audio system on or off. Turn the dial to adjust the volume.
- P **Function button 2:** Press the button to select different functions of the audio system depending on which mode (i.e. radio or CD) you are in.
- Q **Function button 1:** Press the button to select different functions of the audio system depending on which mode (i.e. radio or CD) you are in.
- R **Seek down:** Press the button to go to the next station down the radio frequency band or the previous track on a CD, When in CD mode. In phone mode use the button to begin a phone call. An incoming phone call can be accepted.
- S **PHONE:** Press the button to access the phone feature of the SYNC system by pressing **PHONE** then **MENU**.
- T **AUX:** Press the button to access the AUX and SYNC features, it will also cancel the menu or list browsing.
- U **RADIO:** Press the button to select different radio bands, it will also cancel the menu or list browsing.
- V **CD:** Press the button to change source to CD, it will also cancel the menu or list browsing.
- W **NAV:** Press the button to access the navigation system.

Sound Button

This will allow you to adjust the sound settings (for example bass, middle and treble).

1. Press the sound button.
2. Use the up and down arrow buttons to select the required setting.

3. Use the left and right arrow buttons to make the necessary adjustment. The display indicates the level selected.
4. Press the **OK** button to confirm the new settings.

Waveband Button

Press the **RADIO** button to select from the wavebands available.

Audio System

You can use the selector to return to radio reception when you have been listening to another source.

Alternatively, press the left arrow button to display the available wavebands. Scroll to the required waveband and press **OK**.

Station Tuning Control

Seek Tuning

Select a waveband and briefly press one of the seek buttons. The unit will stop at the first station it finds in the direction you have chosen.

Manual Tuning

1. Press function button 2.
2. Use the left and right arrow buttons to tune down or up the waveband in small increments or press and hold to increment quickly, until you find a station you want to listen to.
3. Press **OK** to continue listening to a station.

Scan Tuning

Scan allows you to listen to a few seconds of each station detected.

1. Press function button 3.
2. Use the seek buttons to scan up or down the selected waveband.
3. Press function button 3 again or **OK** to continue listening to a station.

Station Preset Buttons

This feature allows you to store your favorite stations, they can be recalled by selecting the appropriate waveband and pressing one of the preset buttons.

1. Select a waveband.
2. Tune to the station required.

3. Press and hold one of the preset buttons. A progress bar and message will appear. When the progress bar completes the station has been stored. The audio unit will also mute momentarily as confirmation.

You can repeat this on each waveband and for each preset button.

Note: *When you drive to another part of the country, stations that broadcast on alternative frequencies, and are stored on preset buttons, may be updated with the correct frequency and station name for that area.*

Autostore Control

Note: *This will store up to a maximum of the 10 strongest signals available, either from the AM or the FM waveband, and overwrite the previously stored stations. You can also store stations manually in the same way as other wavebands.*

Note: *You must select either **FM AST** or **AM AST** to use this function.*

- Press the **MENU** button, select audio mode then press and hold the **RADIO** button.
- When the search is complete, sound is restored and the strongest signals are stored on the autostore presets.

Traffic Information Control

Many stations that broadcast on the FM waveband have a TP code to signify that they carry traffic program information.

Turning Traffic Announcements On and Off

Before you can receive traffic announcements, you must press either the **TA** or **TRAFFIC** button. A TA display will appear to show the feature is switched on.

Audio System

If you are already tuned to a station that broadcasts traffic information, TP will also be displayed. Otherwise the unit will search for a traffic program.

When traffic information is broadcast, it will automatically interrupt normal radio or CD playback and Traffic announcement will appear in the display.

If a non-traffic station is selected or recalled using a preset button, the audio unit will remain on that station unless **TA** or **TRAFFIC** is turned off, then on again.

Note: *If traffic announcement is on and you select a preset or manual tune to a non traffic announcement station no traffic announcement will be heard.*

Note: *When you are listening to a non traffic announcement station and turn traffic announcement off and on again a TP seek will occur.*

Traffic Announcement Volume

Traffic announcements interrupt normal broadcasts at a preset minimum level that is usually louder than normal listening volumes.

To adjust the preset volume:

- Use the volume control to make the necessary adjustment during an incoming traffic announcement broadcast. The display will show the level selected.

Ending Traffic Announcements

The audio unit will return to normal operation at the end of each traffic announcement. To end the announcement prematurely, press **TA** or **TRAFFIC** during the announcement.

Note: *If you press **TA** or **TRAFFIC** at any other time it will switch all announcements off.*

Automatic Volume Control

When available, automatic volume control adjusts the volume level to compensate for engine noise and road speed noise.

1. Press the **MENU** button and select **AUDIO**.
2. Select **AVC LEVEL** or **ADAPTIVE VOL**.
3. Use the left or right arrow button to adjust the setting.
4. Press the **OK** button to confirm your selection.
5. Press the **MENU** button to return.

Digital Signal Processing

Digital Signal Processing Occupancy

This feature takes into account the differences in distance from the various speakers in your vehicle to each seat. You must select the correct sitting position for the audio to be correctly set.

Digital Signal Processing Equalizer

Select the music category that most suits your listening preference. The audio output will change to enhance the particular style of music chosen.

Changing the Digital Signal Processing Settings

1. Press the **MENU** button.
2. Select **AUDIO** or **AUDIO SETTINGS**.
3. Scroll to the required digital signal processing function.
4. Use the up and down arrow buttons to select the required setting.
5. Press the **OK** button to confirm your selection.
6. Press the **MENU** button to return.

Audio System

News Broadcasts

Your audio unit may interrupt normal reception to broadcast news bulletins from stations on the FM waveband, radio data system or other enhanced network linked stations.

The display will indicate there is an incoming announcement, during news broadcasts. When the audio unit interrupts for a news broadcast the preset volume level will be the same as traffic announcements.

1. Press the **MENU** button.
2. Select **AUDIO** or **AUDIO SETTINGS**.
3. Scroll to **NEWS** and turn on or off with the **OK** button.
4. Press the **MENU** button to return.

Alternative Frequencies

The majority of programs that broadcast on the FM waveband have a program identification code, it can be recognized by audio units.

When your vehicle moves from one transmission area to another with the alternative frequencies tuning switched on, this function will search for the strongest station signal.

Under certain conditions, however, alternative frequencies tuning may temporarily disrupt normal reception.

When selected, the unit continually evaluates signal strength and, if a better signal becomes available, the unit will switch to that alternative. It mutes while it checks a list of alternative frequencies and if necessary, it will search once across the selected waveband for a genuine alternative frequency.

It will restore radio reception when it finds one or if one is not found, the unit will return to the original stored frequency.

When selected, AF may appear in the display.

1. Press the **MENU** button.
2. Select **AUDIO** or **AUDIO SETTINGS**.
3. Scroll to **ALTERNAT FREQ.** or **ALTERNATIVE FREQ.** and turn on or off with the **OK** button.
4. Press the **MENU** button to return.

Regional Mode

Regional mode controls the behavior of alternative frequencies switching between regionally related networks of a parent broadcaster. A broadcaster may run a fairly large network across a large part of the country. At various times of the day this large network may be broken down into a number of smaller regional networks, typically centered on major towns or cities. When the network is not split into regional variants, the whole network carries the same programming.

Regional mode on: This prevents random alternative frequency switches when neighboring regional networks are not carrying the same programming.

Regional mode off: This allows a larger coverage area if neighboring regional networks are carrying the same programming, but can cause 'random' alternative frequency switches if they are not.

1. Press the **MENU** button.
2. Select **AUDIO** or **AUDIO SETTINGS**.
3. Scroll to **RDS REGIONAL** and turn on or off with the **OK** button.
4. Press the **MENU** button to return.

Audio System

AUDIO UNIT - VEHICLES WITH: AM/FM/DIGITAL AUDIO BROADCAST (DAB) RADIO

WARNING

 Driving while distracted can result in loss of vehicle control, crash and injury. We strongly recommend that you use extreme caution when using any device that may take your focus off the road. Your primary responsibility is the safe operation of your vehicle. We recommend against the use of any handheld device while driving and encourage the use of voice-operated systems when possible. Make sure you are aware of all applicable local laws that may affect the use of electronic devices while driving.

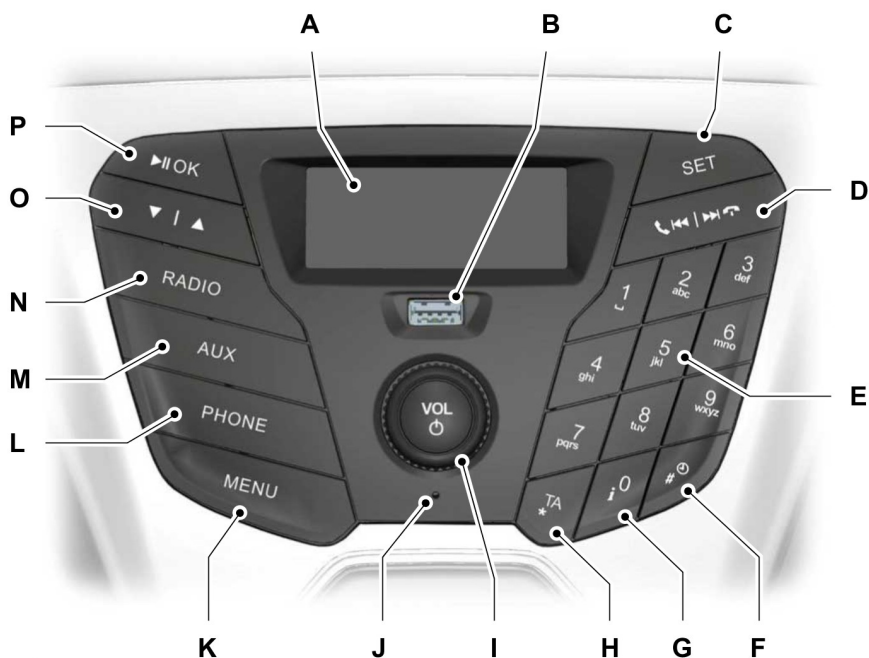

E161197

Audio System

- A **Display:** Shows the status of the current mode selected.
- B **USB socket:** Insert to play audio from a compatible external device or memory stick.
- C **SET:** Press the button to adjust the sound settings for bass, treble, balance and fade.
- D **Seek up:** Press the button to go to the next station up the radio frequency band or the next track. **Seek down:** Press the button to go to the next station down the radio frequency band or the previous track. In Bluetooth audio and USB modes press the buttons to go to the next or previous track.
- D **Dial and end call:** Press the button to make and end a call.
- E **Numeric keypad:** Press the button to recall a previously stored station. To store a favorite station press and hold until the sound returns.
- F **Clock:** Press the button to select clock setup.
- G **Information:** Press the button to access more information if it does not fit the display.
- H **TA:** Press the button to turn traffic announcements on or off and cancel announcements during an active announcement.
- I **On, Off and Volume:** Press the button to switch the audio system on or off. Turn the dial to adjust the volume.
- J **Microphone:** Cell phone microphone.
- K **MENU:** Press the button to access different audio system features, depending on which mode has been selected.
- L **PHONE:** Press the button to access the Bluetooth phone feature of the system by pressing **PHONE** then **MENU**. When paired further presses of this button will display phone name, signal strength and the battery level.
- M **AUX:** Press the button to access Bluetooth audio streaming, USB or Aux input playback.
- N **RADIO:** Press the button to select different radio bands. Press to cancel the menu or list browsing.
- O **Cursor up and down:** Press a button to scroll through on-screen choices. In radio mode press to manual tune.
- P **OK, Play and Pause:** Press the button to confirm on-screen selections. Press to play or pause during playback with compatible external devices.

Set Button

This will allow you to adjust the sound settings (for example bass, treble, balance and fade).

1. Press the **SET** button until the required setting is displayed.
2. Use the up and down arrow buttons to select the required level.

Audio System

3. Press the **OK** button to confirm the new settings.

Waveband Button

Press the **RADIO** button to select from the wavebands available.

You can use the button to return to radio reception when you have been listening to another source.

Station Tuning Control

Seek Tuning

Select a waveband and briefly press one of the seek buttons. The unit will stop at the first station it finds in the direction you have chosen.

Manual Tuning

Use the up and down arrow buttons to tune down or up the waveband in small increments or press and hold to increment quickly, until you find a station you want to listen to.

Station Preset Buttons

This feature allows you to store your favorite stations. They can be recalled by selecting the appropriate waveband and pressing one of the preset buttons.

1. Select a waveband.
2. Tune to the station required.
3. Press and hold one of the preset buttons. A progress bar and message will appear. When the progress bar completes the station has been stored. The audio unit will also mute momentarily as confirmation.

You can repeat this on each waveband and for each preset button.

Note: *When you drive to another part of the country, stations that broadcast on alternative frequencies, and are stored on preset buttons, may be updated with the correct frequency and station name for that area.*

Traffic Information Control

Many stations that broadcast on the FM waveband have a TP code to signify that they carry traffic program information.

Turning Traffic Announcements On and Off

Before you can receive traffic announcements, you must press either the **TA** or **TRAFFIC** button. A TA display will appear to show the feature is switched on.

If you are already tuned to a station that broadcasts traffic information, TP will also be displayed. Otherwise the unit will search for a traffic program.

When traffic information is broadcast, it will automatically interrupt normal radio or device playback.

If a non-traffic station is selected or recalled using a preset button, the audio unit will remain on that station unless **TA** or **TRAFFIC** is turned off, then on again.

Note: *If traffic announcement is on and you select a preset or manual tune to a non traffic announcement station no traffic announcement will be heard.*

Note: *When you are listening to a non traffic announcement station and turn traffic announcement off and on again a TP seek will occur.*

Traffic Announcement Volume

Traffic announcements interrupt normal broadcasts at a preset minimum level that is usually louder than normal listening volumes.

Audio System

To adjust the preset volume use the volume control to make the necessary adjustment during an incoming traffic announcement broadcast. The display will show the level selected.

Ending Traffic Announcements

The audio unit will return to normal operation at the end of each traffic announcement. To end the announcement prematurely, press **TA** or **TRAFFIC** during the announcement.

Note: *If you press **TA** or **TRAFFIC** at any other time it will switch all announcements off.*

News Broadcasts

Your audio unit may interrupt normal reception to broadcast news bulletins from stations on the FM waveband, radio data system or other enhanced network linked stations.

The display will indicate there is an incoming announcement, during news broadcasts. When the audio unit interrupts for a news broadcast the preset volume level will be the same as traffic announcements.

1. Press the **MENU** button.
2. Scroll to **NEWS** and turn on or off with the up and down arrow buttons.
3. Press the **OK** button to return.

Alternative Frequencies

The majority of programs that broadcast on the FM waveband have a program identification code, it can be recognized by audio units.

When your vehicle moves from one transmission area to another with the alternative frequencies tuning switched on, this function will search for the strongest station signal.

Under certain conditions, however, alternative frequencies tuning may temporarily disrupt normal reception.

When selected, the unit continually evaluates signal strength and, if a better signal becomes available, the unit will switch to that alternative. It mutes while it checks a list of alternative frequencies and if necessary, it will search once across the selected waveband for a genuine alternative frequency.

It will restore radio reception when it finds one or if one is not found, the unit will return to the original stored frequency.

When selected, AF will appear in the display.

1. Press the **MENU** button.
2. Scroll to **AF** and turn to auto or off with the up and down arrow buttons.
3. Press the **OK** button to return.

Regional Mode

Regional mode controls the behavior of alternative frequencies switching between regionally related networks of a parent broadcaster. A broadcaster may run a fairly large network across a large part of the country. At various times of the day this large network may be broken down into a number of smaller regional networks, typically centered on major towns or cities. When the network is not split into regional variants, the whole network carries the same programming.

Regional mode on: This prevents random alternative frequency switches when neighboring regional networks are not carrying the same programming.

Regional mode off: This allows a larger coverage area if neighboring regional networks are carrying the same programming, but can cause random alternative frequency switches if they are not.

Audio System

1. Press the **MENU** button.
2. Scroll to **REGION** and turn on or off with the up and down arrow buttons.
3. Press the **OK** button to return.

Phone

Note: Using the system with the engine off will drain the battery.

Note: As no common agreement exists, cell phone manufacturers are able to implement a variety of profiles in their Bluetooth devices. Because of this, an incompatibility can occur between the phone and hands free system, which in some cases may significantly degrade the system performance. To avoid this situation, only recommended phones should be used. To check your cell phone's compatibility, refer to your device's manual or visit the regional Ford website.

This section describes the functions and features of the Bluetooth cell phone hands free system.

The Bluetooth cell phone part of the system provides interaction with the audio system and your cell phone. It allows you to use the audio system to make and receive calls without having to hold your cell phone.

Bluetooth Setup

Note: Up to five Bluetooth devices can be paired to the system.

Note: If there is an ongoing call when the phone in use is selected as the new active phone, the call is transferred to the vehicle audio system.

Note: Even if connected to the system, your phone can still be used in the usual way.

Note: A call will be disconnected if the audio unit is switched off. If the ignition is switched off the phone call will remain in progress.

Before you can use your cell phone with your vehicle it must be paired to the audio system.

The following procedure is required before an initial Bluetooth phone connection can be made.

1. Press the **PHONE** button and then keep pressing the **MENU** button to scroll to the **ADD DEVICE** display. Press the **OK** button.
2. Press the **OK** button again and note the six digit number displayed.
3. Search for Bluetooth devices using the cell phone. For information on phone settings, refer to your phone user guide.
4. Select **FORD AUDIO** from the list of Bluetooth devices found by your phone.
5. Enter the six digit number into your phone when prompted to pair the audio system and phone. If the audio display changes to **SECURE PIN**, together with a different six digit number you do not need to enter a code into your phone. Check the number on the audio display matches the number displayed on your phone and confirm pairing if prompted.
6. Once pairing has been successful **SET PRIMARY** will be displayed on the audio display.
7. Press the **OK** button twice to confirm your phone as the primary device for all future connections.
8. **LOAD PHONEBK** will then be displayed on the audio unit. Press the **OK** button twice to confirm that the contents of your phonebook are downloaded to the system.
9. The Bluetooth device name is displayed on the audio unit.

Audio System

Phonebook Downloading

If your phonebook was not downloaded during initial Bluetooth pairing follow this process:

1. Press the **PHONE** button and then keep pressing the **MENU** button to scroll to the **LOAD PHONEBK** display.
2. Press the **OK** button.

Deleting a Paired Device or Phone

To remove a paired device follow this process:

1. Press the **PHONE** button and then keep pressing the **MENU** button to scroll to the **DEL DEVICE** display.
2. Press the **OK** button. The first paired device name will be shown. Scroll to the required device name using the up and down arrow buttons. Select delete all to erase all paired devices.
3. Press the **OK** button multiple times to unpair the device from the audio unit.

Privacy Mode

You can transfer a call from hands free to private mode during an active call.

Press the **MENU** button until **PRIVACY** appears, then press the **OK** button to transfer. To return to hands free mode, press the dial button.

Phone Menu Options

Press the **PHONE** button to select phone mode. Press the **PHONE** button again to display information such as phone name, signal strength and battery level.

When in phone mode, press the **MENU** button to scroll through the various phone options:

- Redial.
- Phonebook.
- Call History.

- Add Device.
- Select Device.
- Set Primary.
- Delete Device.
- Bluetooth on and off.
- Load Phonebook.

Press the **OK** button to select the required option, and use the up and down arrows to change features.

Making and Receiving Calls

Outgoing calls can be made by:

- entering a number using the keys on the radio
- selecting a contact from the downloaded phonebook
- selecting a number or contact from the call history log
- using quick dial by pressing one of the radio preset buttons
- using the redial function
- using the cell phone.

Incoming calls can be answered by:

- pressing the call pickup button on the audio unit
- using the cell phone.

Calls can be rejected using the end call button on the audio unit, or by using the cell phone directly.

USB

Note: Only use USB Mass-Storage device compliant devices.

Note: Always switch your audio unit to a different source (for example the radio) before unplugging the USB device.

Note: Do not install or connect USB hubs or splitters.

Audio System

Note: The system is only designed to recognize and read suitable audio files from a USB device that conforms to the USB Mass-Storage device class or an iPod. Not all available USB devices can be guaranteed to function with the system.

Note: It is possible to connect compatible devices with a trailing USB lead as well as those that plug into the USB socket directly (for example USB memory sticks and pen drives).

Note: Some USB devices with a higher power consumption may not be compatible (for example some larger hard drives).

Note: Access time to read the files on the external device will vary depending upon factors such as the file structure, size and device content.

The audio unit supports a range of external devices. Once connected, control of the external device is possible via the audio unit.

Operating the USB Device

Note: USB playback will start automatically when you connect a compatible device. To turn this feature off, select **AUTOPL** and then select **OFF** using the menu function.

Connect the device to the audio unit.

Select the USB device as the audio source by pressing the **AUX** button until the USB screen appears in the display. After first connecting the USB device, the first track within the first folder will start to play automatically. Following audio source switching, the position of playback on the USB device is remembered.

Press the seek up and down keys to skip backward and forward through tracks. Press and hold to fast forward and reverse through the track.

iPod

Connect the iPod to the audio unit.

Select the iPod as the audio source by pressing the **AUX** button until **IPOD** appears in the display. After first connecting the iPod, the first track within the first folder will start to play automatically. Following audio source switching, the position of playback on the iPod is remembered.

Press the seek up and down keys to skip backward and forward through tracks.

Press and hold the seek keys to enable fast rewind or fast forward through track content.

Various functions may be controlled from the audio unit including:

- Next and previous track select.
- Track seek.
- Shuffle.
- Repeat.

Bluetooth Audio Streaming

Note: Make sure the device is paired before using this feature.

Compatible Bluetooth devices can be connected to the audio unit to playback using the vehicle audio system.

Select the device as the audio source by pressing the **AUX** button until **BT AUDIO** appears in the display.

The device playback can be controlled using the audio unit buttons play, pause, next and previous track.

Declaration of Conformity

Hereby, Visteon Corporation, declares that this Bluetooth enabled car radio is in compliance with the essential requirements and other relevant provisions of Directive 1999/5/EC.

Audio System

EC Declaration of Conformity

Hereby,

Name of manufacturer: Palmela Electronics – Visteon Corporation
Address: Estrada Nacional 252, KM 12 Volta Da Pedra
City: Palmela
Country: Portugal

declares that this equipment:

Product description: VE-BT001 - ULC Medialess Radio – Bluetooth enabled car radio
Type designation(s): VE-BT001
Trademark: Visteon

is in compliance with the essential requirements and other relevant provisions of Directive 55013:2001 + A1:2003 +A2:2006
EN 301 489 -1, EN 301 489 -17
EN 300 328 v1.7.1
EN 60950-1 :2006 + All :2009 +A1:2010+A12:2011 IEG 60950-1 :2005 (2nd Edition):AM 1 :2009

E167208

DIGITAL AUDIO

The system allows you to listen to DAB (Digital Audio Broadcast) radio stations.

Note: Coverage differs from region to region and will influence the quality of reception. It is broadcast nationwide, regionally and locally.

The following formats are supported:

- DAB
- DAB+
- DMB-Audio (Digital Multimedia Broadcasting).

Ensembles

Ensembles contain a group of radio stations. Each ensemble can consist of several different radio stations.

Audio System

The radio station name displays below the ensemble name.

Note: *When you tune from one ensemble to another, it can take a while until the system synchronizes to the next ensemble. The system mutes during synchronization.*

Selecting Radio Band

DAB1 and DAB2 operate in the same way. You can store up to 10 different presets on each band.

1. Press the **RADIO** button.
2. Press the left arrow button to display the available wavebands.
3. Select **DAB1** or **DAB2**.

Radio Station Tuning Control

Press the **RADIO** button and select **DAB1** or **DAB2**. Both preset banks operate in the same way and can store up to 10 different preset radio stations.

Note: *When you reach the first or last radio station within an ensemble, further tuning will skip to the next ensemble. There may be a delay during this change and the audio will briefly mute.*

Seek Tuning

1. Press a seek button. The system will stop at the first radio station it finds in the direction chosen.

Radio Station List

This feature displays all the available radio stations in a list.

1. Press function button 1.
2. Press the left or right arrow buttons to change ensembles. Press the up or down arrow button to navigate to your required radio station.
3. Press **OK** to confirm your selection.

Note: *The display will only show radio stations in the current ensemble.*

Manual Tuning

1. Press function button 2.
2. Press the left or right arrow button to tune up or down the waveband in small increments. Press and hold to move through the waveband quickly.
3. Press **OK** to confirm your selection.

Note: *Seek tuning is also possible within this screen.*

Radio Station Preset Buttons

This feature allows you to store up to 10 favorite radio stations from any ensemble in each preset bank.

1. Select a radio station.
2. Press and hold one of the preset buttons. A progress bar and message will appear. When the progress bar completes the radio station has been stored. The system will mute momentarily as confirmation.

Once stored press a preset button at any time to select a favourite radio station.

Note: *Radio stations stored on the preset buttons may not always be available if you have left the coverage area. The system will mute when this happens.*

Radio Text

You can display extra information. For example; artist name. To switch this option on, select a radio station and press function button 3.

Note: *Extra information may not always be available.*

Service Linking

If you leave the coverage area of a DAB radio station the system will automatically switch to the corresponding FM radio station.

Audio System

You can switch this feature on and off using the information display. See **General Information** (page 63).

Note: If a DAB radio station has no corresponding FM radio station, the audio will mute when attempting to switch.

Note: The system will display the FM symbol when DAB and FM radio stations link.

AUXILIARY INPUT JACK

WARNINGS



Driving while distracted can result in loss of vehicle control, accident and injury. We strongly recommend that you use extreme caution when using any device or feature that may take your focus off the road. Your primary responsibility is the safe operation of your vehicle. We recommend against the use of any handheld device while driving and encourage the use of voice-operated systems when possible. Make sure you are aware of all applicable local laws that may affect the use of electronic devices while driving.



For safety reasons, do not connect or adjust the settings on your portable music player while your vehicle is moving.



Store the portable music player in a secure location, such as the center console or the glove box, when your vehicle is in moving. Hard objects may become projectiles in a collision or sudden stop, which may increase the risk of serious injury. The audio extension cable must be long enough to allow the portable music player to be safely stored while your vehicle is moving.

The auxiliary input jack allows you to connect and play music from your portable music player through your vehicle speakers. You can use any portable music player designed for use with headphones. Your audio extension cable must have male one-eighth inch (three and one-half millimeter) connectors at each end.

1. Make sure your vehicle is stationary with the radio and portable music players turned off.
2. Plug the extension cable from the portable music player into the auxiliary input jack.
3. Switch the radio on. Select either a tuned FM station or a CD.
4. Adjust the volume as desired.
5. Switch the portable music player on and adjust its volume to half its maximum level.
6. Press **AUX** until **LINE** or **LINE IN** appears in the display. You should hear music from your device even if it is low.
7. Adjust the volume on your portable music player until it reaches the volume level of the FM station or CD. Do this by switching back and forth between the AUX and FM or CD controls.

USB PORT



E142604

Audio System

The USB port allows you to plug in media playing devices, memory sticks and charge devices (if supported). See **SYNC™** (page 237).

MEDIA HUB

The media hub is located in the center console and has the following features:

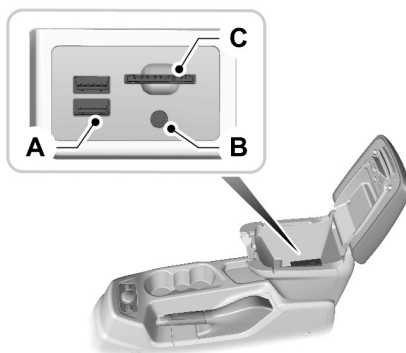

E163858

- A USB ports
- B Audio input
- C SD card slot

AUDIO TROUBLESHOOTING

Audio unit display	Rectification
PLEASE CHECK CD	General error message for CD fault conditions, such as cannot read the CD, data-CD inserted, etc. Make sure the disc is loaded correct way up. Clean and re-try, or replace disc with known music disc. If error persists contact your dealer.
CD DRIVE MALFUNCTION	General error message for CD fault conditions such as possible mechanism fault.
CD DRIVE HIGH TEMP	Ambient temperature too hot – unit will not work until it has cooled down.

Navigation

Press the relevant button on the unit bezel to access the system functions. This will take you into the selected mode.

For instructions on how to operate the audio unit and the available navigation features, see the relevant audio unit procedure. See **Audio System** (page 206).

Loading Map Data

WARNINGS



The indicated maximum speed may not be applicable to your vehicle. It is always your responsibility to control your vehicle, supervise any system and obey the correct speed limit. Failure to do so could result in loss of vehicle control.



The front glass on the liquid crystal display may break if hit with a hard object. If the glass breaks, do not touch the liquid crystalline material. In case of contact with the skin, wash immediately with soap and water.

Note: Do not switch the ignition on or attempt to start the engine while the software is updating.

Note: Do not clean the unit with solvents or aerosol cleaning agents. Use only a damp cloth.

Note: The navigation SD card must be in the SD card slot to operate the navigation system. If you need a replacement SD card, see an authorized dealer.

Note: The SD card slot is spring-loaded. To remove the SD card, push the card in and release it. Do not attempt to remove the card without first pushing it in. This could cause damage.



E129900

1. Load the navigation SD card into the slot.
2. Press the **NAV** button. The road safety warning confirms the map data import was successful.
3. The system is now ready to use.

For map updates and system upgrades, see an authorized dealer.

Note: You can only use Ford licensed data.

Road Safety

WARNING



Driving while distracted can result in loss of vehicle control, crash and injury. We strongly recommend that you use extreme caution when using any device that may take your focus off the road. Your primary responsibility is the safe operation of your vehicle. We recommend against the use of any handheld device while driving and encourage the use of voice-operated systems when possible. Make sure you are aware of all applicable local laws that may affect the use of electronic devices while driving.

Navigation

Note: You are ultimately responsible for the safe operation of your vehicle and must evaluate whether it is safe to follow route suggestions. Navigation features are provided only as an aid. Driving decisions based on observations of local conditions and existing traffic regulations must be observed. Do not follow route suggestions if they would result in an unsafe or illegal maneuver, an unsafe situation, or if you would be directed into an area that you consider unsafe. Maps used by this system may be inaccurate due to errors, changes in roads, traffic or driving conditions.

Safety Information

If detailed viewing of route instructions is necessary, pull off the road when it is safe to do so and park your vehicle.

Menu Structure

You can access the menu using the information and entertainment display control. See **Information Displays** (page 63).

Note: Some options may appear slightly different or not at all if the items are optional.

Navigation	
Route*	Active guidance
	Route sections list
	Block next section
	Unblock rte sctn
Destination input*	Country
	City/postcode
	Street
	District
	Start guidance
Traffic*	TA
	TMC for route
	All TMC
	Block next section
	Route sections list
	Unblock rte sctn
Home address*	Start guidance
	Change address

Navigation

Navigation		
Last destinations*		
Favourites*	Favourites (A-Z)	
Points of interest*	POIs nearby	
	Near destination	
	Along motorway	
	POIs near address	
	Search by name	
Tour planning*	New tour	
	Stored tours	
Store position*		
Route options*	Route	Eco
		Fast
		Short
		Always ask
	Driver:	Leisurely
		Normal
		Fast
	Eco settings	Trailer
		Roof box
	Dynamic	
	Motorway	
	Tunnel	
	Ferry/motorail	
	Toll	
	Seasonal roads	
Toll sticker		

Navigation

Navigation	
Special functions*	GPS info
	System info
	Enter position
	Demo mode

*For a description on these menu items refer to the relevant table.

Route Options

Press the **NAV** button and scroll to **Route options**. You can then set your route options for any of the following.

Route

You can select **Always ask** to make sure that you are always given the choice of route option for your journey.

Eco

Uses the most fuel efficient route.

Note: *Your driving style will influence this.*

Fast

Uses the fastest route possible.

Short

Uses the shortest distance possible.

Driver

Leisurely

This option will calculate your time of arrival based on a leisurely drive to the destination.

Normal

This option will calculate your time of arrival based on a normal drive to the destination.

Fast

This option will calculate your time of arrival based on a fast drive to the destination.

Eco Settings

Trailer

Use this feature to change the economy settings of your journey relating to whether or not you are towing a trailer and if so the size of trailer being towed.

Roof Box

Use this feature to change the economy settings of your journey relating to the use of a roof box.

Dynamic

When switched on, and if the unit is receiving a valid traffic message channel signal, the route will be automatically updated to take into account real time traffic incidents or congestion.

Note: *This feature can be useful in avoiding delays or hold ups on journeys.*

Freeway

When switched off the system will avoid freeways on your route and automatically update your route distance and timings.

Navigation

Tunnel

When switched off the system will avoid tunnels on your route and automatically update your route distance and timings.

Ferries and Car Trains

When switched off the system will avoid ferry crossings and car train facilities on your route and automatically update your route distance and timings.

Toll

When switched off the system will avoid toll roads on your route and automatically update your route distance and timings.

Seasonal Roads

When switched off the system will avoid seasonal roads (for example, mountain passes) on your route and automatically update your route distance and timings.

Toll Sticker

When switched off the system will avoid toll routes and automatically update your route distance and timings.

Information

Press the information button to view details of your current location or journey. During active route guidance pressing this button will repeat the last navigation instruction.

Setting Your Navigation Preferences

Select settings for the system to take into account when planning your route.

Press the NAV button and choose any of the following options.

When You Select	You Can
Destination input	Enter your destination details (for example enter city names, enter street names or pick a place from a map).
Traffic	Choose how you want the system to handle traffic problems along your route (for example, block sections on route).
Home address	See the location on the map currently stored as the home position. Only one entry can be saved as the home address.
Last destinations	Access a history of previous destinations entered in the system. Select the required repeat destination from the list.
Favorites	See a list of your saved favorites.
Points of interest	Search for and select points of interest nearby, on your route or at your destination. You can search by name or by category.

Navigation

When You Select	You Can
Tour planning	Set up and store a new tour by entering a number of different destinations and select the order in which you wish to visit them. You can also modify an existing tour or recall a previous tour. The system will automatically calculate and display your chosen journey.
Store position	Store and name your current position. This will automatically save in your favorites.
Route options	Set your route options from the available list.
Special functions	Select GPS and system information or a demonstration of the system functionality. Select a demonstration mode where the system will simulate a journey whilst the vehicle is stationary. You can manually select a vehicle start position.

Press the MENU button, select the navigation option and choose any of the following options.

When You Select	You Can
Route options	Set your route options.
Map display	Customize the map display for your journey (for example arrows on map, arrival times and map content).
Assistance options	Customize display information for your journey (for example signs, lanes and speed limits). Turn the hazard warning feature on or off.
Personal data	Delete personal data (for example your home address).
Reset all settings	Reset the navigation settings.

Storing Your Home Address

1. Press the **NAV** button.
2. Select the home address option.
3. Enter the required details using the arrow buttons.
4. Press the confirm function button.

Note: You can display the current home address by pressing the information button.

Note: Your last destination will automatically display if you go to change your home address.

Adding a Favorite

1. Press the **NAV** button.
2. Scroll to the destination input option.
3. Enter the required details using the arrow buttons.
4. Press the store function button.

Navigation

Note: *If you select store position, this will also save the destination in your favorites.*

Selecting a Favorite

1. Press the **NAV** button.
2. Select the favorites option.
3. Scroll to the required destination using the arrow buttons.
4. Press the **OK** button to start navigation.

Adjusting the Navigation Voice Level

You can adjust the voice prompt level during an active voice prompt by using the volume control.

Note: *During active route guidance pressing the information button will repeat the last navigation instruction.*

Nav Audio Mixing

This feature allows you to adjust the volume mix between the audio unit and navigation voice level. See **General Information** (page 63).

Tolerant Destination Input

This function will search a number of destinations with a similar spelling to what you have entered. This is helpful if you are unsure on how to spell a destination.

1. Press the **NAV** button.
2. Scroll to the destination input option.
3. Before entering your destination details select **Tolerant** and then begin to input your destination.
4. Press the **OK** button. The system will search for destinations with similar spellings.
5. Use the arrow buttons to select a destination from the list and press the **OK** button to confirm your destination.

Route Displays

Map Display

Press the **MAP** button to view map mode. This view will show your current location with your vehicle in the center shown as an arrow surrounded by a circle. The arrow will face in the direction of travel.

The information on the top line gives the name of the current road, or the next road to take if a turn is approaching.

You can change the way the map is displayed by altering the zoom and orientation settings. Press function button one. The current map scale is shown on the display.

Map scale settings may be set between 0.05 miles to 500 miles or 50 meters to 500 kilometers, with an auto setting on the top. The auto setting continuously changes the map scale according to vehicle speed and the road type being driven.

You can use the arrow buttons to change the view to 2D, turn-by-turn, 3D or a clean view.

Zoom

This feature will automatically increase the zoom on the map display at times when you are required to make a turn, or perform more complex maneuvers. Shortly after the zoom scale will return to the previous level when in auto mode.

Manual: Press function button one and adjust the setting using the left or right arrow buttons. Press **OK** to confirm your setting.

Auto: Press function button one and using the up or down arrow key select the auto option. Press **OK** to confirm your setting.

Navigation

Move

When you are in map mode, press function button two. You can now use the arrow buttons on the audio unit to move around the map.

Press function button two again to return to the original view.

Navigation Display

After commencing a navigation route, the default screen is the main navigation screen.

Once an active route is underway, guidance will be given by on-screen information and voice prompts. Whichever audio source you wish to leave the unit in, basic turn by turn and distance information will remain on the screen in the form of a graphic inset. You do not need to leave the unit on the main navigation screen when you are navigating a route. Press the **MAP** button at any time to return to the main navigation screen. Slightly more detailed information on your route may be available using the main navigation screen if required.

Hazard Spot Warning

The system supports a hazard spot warning feature which informs you with visible and audible feedback about hazardous traffic areas. You can switch the system on and off using the information and entertainment display menu. See **Assistance options** in the navigation menu.

Note: *This feature is only available in certain countries.*

Navigation Map Updates

Annual navigation map updates are available for purchase. See an authorized dealer.

Type Approvals



SD Logo is a trademark.

The navigation software is based in part on the work of the FreeType team © 2006

The navigation software is based in part on the work of the independent JPEG Group.

GENERAL INFORMATION

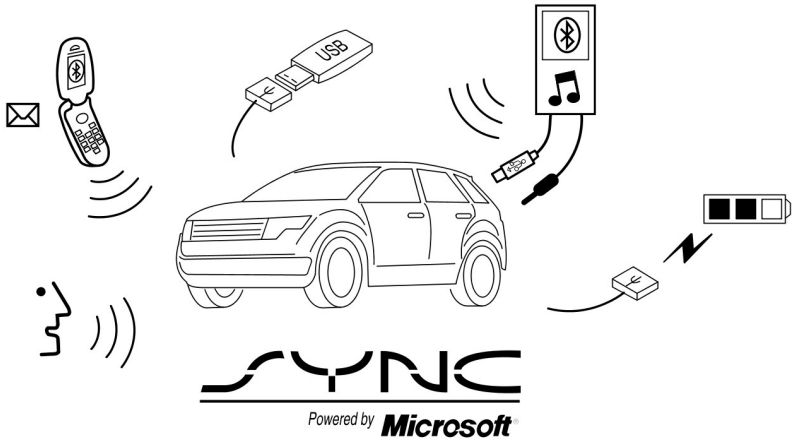

E142598

SYNC is an in-vehicle communications system that works with your Bluetooth-enabled cell phone and portable media player.

This allows you to:

- Make and receive calls
- Access and play music from your media player
- Use emergency assistance
- Access phonebook contacts and music using voice commands
- Stream music from your connected cell phone
- Select pre-defined text messages

- Use the advanced voice recognition system
- Charge your USB device (if your device supports this).

Make sure that you review your device's manual before using it with SYNC.

Support

For further support, see an authorized dealer. For more information, visit the regional Ford website.

Safety Information

WARNING



Driving while distracted can result in loss of vehicle control, crash and injury. We strongly recommend that you use extreme caution when using any device that may take your focus off the road. Your primary responsibility is the safe operation of your vehicle. We recommend against the use of any hand-held device while driving and encourage the use of voice-operated systems when possible. Make sure you are aware of all applicable local laws that may affect the use of electronic devices while driving.

When using SYNC:

- Do not operate playing devices if the power cords or cables are broken, split or damaged. Carefully place cords and cables where you cannot step on them or they do not interfere with the operation of pedals, seats, compartments or safe driving abilities.
- Do not leave playing devices in your vehicle during extreme conditions as it could cause them damage. Refer to your device's manual for further information.
- Do not attempt to service or repair the system. See an authorized dealer.

Privacy Information

When a cell phone is connected to SYNC, the system creates a profile that is linked to that cell phone. The system creates the profile to offer you more mobile features and to operate more efficiently. Among other things, this profile may contain data about your phonebook, text messages (read and unread) and call history. This will include the history of calls when your cell phone was not connected to the system. If you connect a media player, the system creates and retains an index of

supported media content. The system also records a short development log of approximately 10 minutes of all recent system activity. The log profile and other system data may be used to improve the system and help diagnose any problems that may occur.

The cell phone profile, media player index and development log will remain in the system unless deleted. They are generally accessible in your vehicle only when you connect your cell phone or media player. If you no longer plan to use the system or your vehicle, we recommend you complete a master reset to erase all stored information. See **Information Displays** (page 63).

Special equipment is required to access system data. Access to your vehicle's SYNC module is also required. We will not access the system data for any purpose other than as described without consent. Examples where system data can be accessed are for a court order, where required by law enforcement, other government authorities or other third parties acting with lawful authority. Other parties may seek to access the information independently of us. Further privacy information is available. See **SYNC™ Applications and Services** (page 251).

USING VOICE RECOGNITION

This system helps you control many features using voice commands. This allows you to keep your hands on the steering wheel and focus on what is around you.

Helpful Hints

Make sure the interior of your vehicle is as quiet as possible. Wind noise from open windows and road vibrations may prevent the system from correctly recognizing spoken commands.

Before giving a voice command, wait for the system announcement to finish followed by a single beep. Any command spoken before this does not register with the system.

Speak naturally, without long pauses between words.

You can interrupt the system at any time while it is speaking by pressing the voice button. You can also cancel a voice session at any time by pressing and holding the voice button.

Initiating a Voice Session



Press the voice button. A list of available commands appears in the display.

Say	If you want to
"Bluetooth Audio"	Stream audio from your cell phone.
"Cancel"	Cancel the requested action.
"Line in"	Access the device connected to the auxiliary input jack.
"Phone"	Make calls.
"SYNC"	Return to the main menu.
"USB"	Access the device connected to your USB port.
"Voice settings"	Adjust the level of voice interaction and feedback.
"Help"	Hear a list of voice commands available in the current mode.

System Interaction and Feedback

The system provides feedback through audible tones, prompts, questions and spoken confirmations depending on the situation and your chosen level of interaction. You can customize the voice recognition system to provide more or less instruction and feedback.

The default setting is to a higher level of interaction in order to help you learn to use the system. You can change these settings at any time.

Adjusting the Interaction Level



Press the voice button. Say "Voice settings" when prompted, then any of the following:

When you say	The system
"Interaction mode advanced"	Provides less audible interaction and more tone prompts.
"Interaction mode standard"	Provides more detailed interaction and guidance.

The system defaults to the standard interaction mode.

SYNC™

Confirmation prompts are short questions the system asks when it is not sure of your request or when there is more than one possible response to your request. For example, the system may ask if the

command phone is correct.

Press the voice button to change the confirmation prompt setting. Say "Voice settings" when prompted, then any of the following:

When you say	The system
"Confirmation prompts off"	Makes a best guess from the command. You may still occasionally be asked to confirm settings.
"Confirmation prompts on"	Clarifies your voice command with a short question.

The system creates suggestion lists when it has the same confidence level of several options based on your voice commands. When switched on, the system may prompt you with as many as four possibilities for clarification.

For example, say "one" after the tone to call John Doe at home. Say "two" after the tone to call Johnny Doe on mobile. Say "three" after the tone to call Jane Doe at home.

The same logic applies to media content. For example, say "one" after the tone to play John Doe. Say "two" after the tone to play Johnny Doe. Say "three" after the tone to play Jane Doe.

When you say	The system
"Media candidate lists off"	Makes a best guess from the media suggestion list. The system may occasionally ask you questions.
"Media candidate lists on"	Clarifies your voice command for media suggestions.
"Phone candidate lists off"	Makes a best guess from the cell phone suggestion list. The system may occasionally ask you questions.
"Phone candidate lists on"	Clarifies your voice command for cell phone suggestions.

Changing the Voice Settings

You can change the voice settings using the information and entertainment display.

1. Press the **MENU** button.

2. Select **SYNC-Settings**.
3. Select **Voice Settings**.

USING SYNC™ WITH YOUR PHONE

Hands-free calling is one of the main features of SYNC. While the system supports a variety of features, many are dependent on your cell phone's functionality.

At a minimum, most cell phones with Bluetooth wireless technology support the following functions:

- Answering an incoming call.
- Ending a call.
- Using privacy mode.
- Dialing a number.
- Redialing.
- Call waiting notification.
- Caller ID.

Other features such as text messaging using Bluetooth and automatic phonebook download are cell phone dependent features. To check your cell phone's compatibility, refer to your device's manual or visit the regional Ford website.

Pairing a Cell Phone for the First Time

Note: *You must switch on the ignition and radio on.*

Note: *To scroll through the menus, press the up or down arrows on your audio system.*

Wirelessly pairing your cell phone with the system allows you to make and receive hands-free calls.

1. Make sure you switch on the Bluetooth feature on your cell phone before starting the search. Refer to your device's manual if necessary.
2. Press the **PHONE** button. When the audio display indicates that there are no paired phones, select the option to add a phone.

3. When a message to begin pairing appears in the audio display, search for SYNC on your cell phone to start the pairing process.
4. When prompted on your cell phone's display, enter the six-digit PIN provided by the system in the audio display. The display indicates when the pairing is successful.

Depending on your cell phone's capability and your market, the system may prompt you with questions such as setting the current cell phone as the primary cell phone (the cell phone the system automatically tries to connect with first when you switch on the ignition) and downloading your phonebook.

Pairing Subsequent Cell Phones

Note: *You must switch on the ignition and radio on.*

Note: *To scroll through the menus, press the up or down arrows on your audio system.*

1. Make sure you switch on the Bluetooth feature on your cell phone before starting the search. Refer to your device's manual if necessary.
2. Press the **PHONE** button.
3. Select the option for Bluetooth devices.
4. Press the **OK** button.
5. Select the option to add. This starts the pairing process.
6. When a message to begin pairing appears in the audio display, search for SYNC on your device to start the pairing process.
7. When prompted on your cell phone's display, enter the six-digit PIN provided by the system in the audio display. The display indicates when the pairing is successful.

The system may prompt you with questions such as setting the current cell

phone as the primary cell phone and downloading your phonebook.

Cell Phone Voice Commands

"Phone"	
"Call <name>" ¹	"Go to privacy"
"Call <name> at home" ¹	"Hold"
"Call <name> at work" ¹	"Join"
"Call <name> in office" ¹	"Menu" ^{2,4}
"Call <name> on cell" ¹	"Phonebook <name>" ²
"Call <name> on other" ¹	"Phonebook <name> at home" ²
"Call history incoming" ²	"Phonebook <name> in office" ²
"Call history missed" ²	"Phonebook <name> at work" ²
"Call history outgoing" ²	"Phonebook <name> on cell" ²
"Connections" ²	"Phonebook <name> on other" ²
"Dial" ^{1,3}	-

¹ You do not need to say "phone" before saying these commands.

² These commands are not available until your cell phone information has completely downloaded using Bluetooth.

³ See **Dial** table.

⁴ See **Menu** table.

Phonebook Commands

When you ask the system to access something such as a phonebook name or number, the requested information appears in the audio display. Press the voice button and say, "call" to call the contact.

SYNC™

"Dial"
"112" (one-one-two)
"700" (seven hundred)
"800" (eight hundred)
"900" (nine hundred)
"Pound", (#)
"Number <0-9>"
"Asterisk" (*)
"Clear" (deletes all entered digits)
"Delete" (deletes one digit)
"Plus"
"Star"

Note: To exit dial mode, press and hold the phone button or any button on the audio unit.

"Menu"
"(Phone) connections"
"(Phone) settings (message) notification off"
"(Phone) settings (message) notification on"
"(Phone) settings (set) phone ringer"
"(Phone) settings (set) ringer 1"
"(Phone) settings (set) ringer 2"
"(Phone) settings (set) ringer 3"
"(Phone) settings (set) ringer off"
"Phone name"
"Text message inbox"

Words in parenthesis are optional and do not have to be spoken for the system to understand the command.

Making a Call

1. Press the voice button. When prompted, say, "call <name>" or "dial" followed by a number.
2. When the system confirms the number, say, "dial" again to initiate the call.

To erase the last spoken digit, say, "delete" or press the left arrow button on the audio unit. To erase all spoken digits, say "clear" or press and hold the left arrow button on the audio unit.

To end the call, press the end call button on the steering wheel or select the end call option in the audio display and press **OK**.

Receiving a Call

When receiving a call, you can:

- Answer the call by pressing the accept call button on the steering wheel or by selecting the accept call option in the audio display. Press the **OK** button.
- Reject the call by pressing the reject call button on the steering wheel or by selecting the reject call option in the audio display. Press the **OK** button.
- Ignore the call by doing nothing.

Cell Phone Options during an Active Call

During an active call, you have extra menu features that become available such as putting a call on hold and joining calls.

To access this menu, choose one of the options available at the bottom of the audio display or select the option for more.

When you select	You can
Mic. off	Turn off your vehicle's microphone. To turn the microphone on, select the option again.
Privacy	Switch a call from an active hands-free environment to your cell phone for a more private conversation. When selected, the audio display indicates the call is private.
Hold	Put an active call on hold. When selected, the audio display indicates the call is on hold.
Dial a number	Enter numbers using the audio system numeric keypad, for example numbers for passwords.
Join Calls	Join two separate calls. The system supports a maximum of three callers on a multi-party or conference call. 1. Select the option for more. 2. Access the desired contact through the system or use voice commands to place the second call. Once actively in the second call, select the option for more.

When you select	You can
	3. Scroll to the option to join calls and press the OK button.
Phonebook	Access your phonebook contacts. 1. Select the option for more. 2. Scroll to the option for phonebook and press the OK button. 3. Scroll through your phonebook contacts. 4. Press the OK button again when the desired selection appears in the audio display. 5. Press the OK button or dial button to call the selection.
Call History	Access your call history log. 1. Select the option for more. 2. Scroll to the option for call history appears and press the OK button. 3. Scroll through your call history options (incoming, outgoing or missed). 4. Press the OK button again when the desired selection appears in the audio display. 5. Press the OK button or dial button to call the selection.

Accessing Features through the Cell Phone Menu

You can access your call history, phonebook, sent text messages as well as access cell phone and system settings. You can also access advanced features such as emergency assistance.

1. Press the **PHONE** button to enter the cell phone menu.
2. Select one of the options available.

When you select	You can
Dial a number	Dial a number using the audio system numeric keypad.
Redial	Redial the last number called (if available). Press the OK button to select.
Phonebook*	Access your downloaded phonebook. 1. Press the OK button to confirm and enter. You can use the options at the bottom of the screen to access an alphabetical category quickly. You can also use the letters on the keypad to jump in the list. 2. Scroll through your phonebook contacts. 3. Press the OK button again when the desired selection appears in the audio display. 4. Press the OK button or dial button to call the selection.

When you select	You can
Call History*	Access any previously dialed, received or missed calls. 1. Press the OK button to select. 2. Scroll to select incoming calls, outgoing calls or missed calls. Press the OK button to make your selection. 3. Press the OK button or dial button to call the selection. The system attempts to automatically re-download your phonebook and call history each time your cell phone connects to the system. You must switch on the auto download feature if your cell phone supports it.
Speed Dial	Select one of 10 speed dial entries. To set a speed dial entry, go to the phonebook and press and hold one of the numbers on the audio system numeric keypad.
Text message*	Send, download and delete text messages.
BT Devices	Access the option for Bluetooth device menu listings (add, connect, set as primary, on or off, delete).
Phone settings*	View various settings and features on your cell phone.
Emergency Assistance	Turn the SYNC emergency assistance feature on or off.

* This is a cell phone dependent feature.

Text Messaging

Note: *This is a cell phone dependent feature.*

The system allows you to receive, send, download and delete text messages. The system can also read incoming text messages to you so that you do not have to take your eyes off the road.

Receiving a Text Message

Note: *Your cell phone must support downloading text messages using Bluetooth to receive incoming text messages.*

Note: *The system allows only one recipient per text message.*

When a new message arrives, an audible tone sounds and the audio display indicates you have a new message.

You have these options:

- Select the listen option to have the system read the message to you.
- Select the view option to open the text message. Select the ignore option or do nothing and the message goes into your text message inbox. Once selected, you have the ability to have the message read out to you, to view other messages or to select the more option.

- Press the voice button and say "Read text message".
- Select the more option and use the arrow buttons to scroll through further options. Choose from the following:
 - **Reply to sender:** Press the **OK** button to access and then scroll through the list of pre-defined messages to send.
 - **Call sender:** Press the **OK** button to call the sender of the message.
 - **Forward msg:** Press the **OK** button to forward the message to anyone in your phonebook or call history. You can also choose to enter a number.
- **Delete** allows you to delete current text messages from the system (not your cell phone). The audio display indicates when the system has deleted all your text messages.
- **More** allows you to delete all messages or to trigger a download of all unread messages from your cell phone manually.

When you select the option to send a text message, a list of pre-defined messages appear in the audio display.

Sending a Text Message

1. Select the send option when the audio display highlights your desired selection.
2. Select the confirmation option when the contact appears and press the **OK** button again to confirm when the system asks if you would like to send the message. The system sends each text message with a pre-defined signature.

Note: You can send text messages either by choosing a contact from the phonebook and selecting the text option from the audio display or by replying to a received message in the inbox.

Accessing Your Cell Phone Settings

These are cell phone dependent features. Your cell phone settings allow you to access and adjust features such as your ringtone, text message notification, modify your phonebook and set up automatic download.

1. Press the **PHONE** button.
2. Scroll until the phone settings option appears, then press the **OK** button.
3. Scroll to select from the following options:

Sending, Downloading and Deleting Your Text Messages

1. Press the **PHONE** button.
2. Select the text messaging option, and then press the **OK** button.

A list of all available text messages appears.

You can choose from the following options:

- **New** allows you to send a new text message based on a pre-defined set of 15 messages.
- **View** allows you to read the full message and provides the option to have the message read out to you by the system. To go to the next message select the more option. This allows you to reply to the sender, call the sender or forward the message.

When you select	You can
Set as master	If this option is checked, the system will use this cell phone as the master when there is more than one cell phone paired to the system. This option can be changed for all paired cell phones (not only for the active one) using the Bluetooth devices menu.
Phone Status	See the cell phone name, provider name, cell phone number, signal level and battery level. When done, press the left arrow button to return to the cell phone status menu.
Set ringtone	Select which ringtone sounds during an incoming call (one of the system's or your cell phone's). 1. Press the OK button to select and scroll to hear each ringtone. 2. Press the OK button to select. If your cell phone supports in-band ringing, your cell phone's ringtone sounds when you choose the cell phone ringtone option.
Text msg notify	Have the option of hearing an audible tone to notify you when a text message arrives. Press the OK button to adjust the setting for the audible tone.
Phonebook pref.	Modify the contents of your phonebook (such as add, delete or download). Press the OK button to select and scroll between the settings: Add contacts: Press the OK button to add more contacts from your phonebook. Push the desired contacts on your cell phone. Refer to your device's manual on how to push contacts. Delete: Press the OK button to delete the current phonebook and call history. When a message asking you to delete appears, select the option to confirm. The system takes you back to the menu for phone settings. Download now: Press the OK button to select and download your phonebook to the system. Auto-download: Check or uncheck this option to download your phonebook each time your cell phone connects to the system. Downloading times are cell phone dependent and quantity dependent. When you switch on automatic downloading, the system deletes any changes, additions or deletions saved in the system since your last download.

When you select	You can
	When you switch off automatic downloading, the system does not download your phonebook when your cell phone connects to the system. Your phonebook, call history and text messages can only be accessed when your paired cell phone is connected to the system.

Bluetooth Devices

This menu provides access to your Bluetooth devices. Use the arrow buttons to scroll through the menu options. It allows you to add, connect and delete devices and set a cell phone as primary.

Bluetooth Devices Menu Options

1. Press the **PHONE** button.
2. Scroll until the Bluetooth device option appears, then press the **OK** button.
3. Scroll to select from the following options:

When you select	You can
Add	Pair more cell phones to the system. 1. Select the option to add to start the pairing process. 2. When a message to begin pairing appears in the audio display, search for SYNC on your cell phone. Refer to your device's manual if necessary. 3. When prompted on your cell phone's display, enter the six-digit PIN provided by the system in the audio display. The display indicates when the pairing is successful. 4. When the option to set the cell phone as the primary cell phone appears, select either yes or no. 5. Depending on the functionality of your cell phone, the system may ask you extra questions (for example, if you would like to download your phonebook). Select either yes or no to confirm your response.
Delete	Delete a paired cell phone. Select the delete option and confirm when the system asks to delete the selected device. After deleting a cell phone from the list, you need to repeat the full pairing process to connect a phone.
Master	Set a previously paired cell phone as your primary cell phone. Select the master option to confirm the primary cell phone.

SYNC™

When you select	You can
	The system attempts to connect with the primary cell phone every time you switch on the ignition. When you select a cell phone as primary, it appears first in the list and marked with an asterisk.
Conn.	Connect a previously paired cell phone. You can only have one cell phone connected at a time to use the cell phone functionality. When another cell phone is connected, the system disconnects the previous cell phone from the telephone services. The system allows you to use different Bluetooth devices for the cell phone functionality and the Bluetooth audio music playback feature at the same time. Select this option to connect to the selected previously paired cell phone.
Discon.	Disconnects the selected cell phone. Select this option and confirm when asked to. After disconnecting a cell phone, you can reconnect it without repeating the full pairing process.

System Settings

1. Press the **MENU** button.

2. Select the SYNC settings option, and then press the **OK** button.

When you select	You can
Bluetooth on	Check or uncheck this option to turn the Bluetooth interface of the system on or off. Select this option then press the OK button to change the option's status.
Set defaults	Return to the factory default settings. This selection does not erase your indexed information (phonebook, call history, text messages and paired devices). Select this option and confirm when Set defaults? appears in the audio display.
Master reset	Completely erase all information stored on the system (phonebook, call history, text messages and paired devices) and return to the factory default settings. Select this option and confirm when Master reset? appears in the audio display. The display indicates when complete and the system takes you back to the SYNC-Settings menu.
Install on SYNC	Install applications or software updates you have downloaded.

When you select	You can
	Select this option and confirm when Install on SYNC appears in the audio display. There must be a valid SYNC application or update available on the USB thumb drive in order to finish an installation successfully.
System info	Display the system's version numbers as well as its serial number. Press the OK button to select.
Voice settings	The voice settings submenu contains various options. See Using Voice Recognition (page 238).
Browse USB	Browse the actual menu structure of the connected USB device. Press the OK button and use the up or down arrows to scroll through the folders and files. Use the left or right arrows to enter and leave a folder. You can directly select media content for playback from this menu.
Emergency assistance	You can turn the emergency assistance feature on or off. See SYNC™ Applications and Services (page 251).

SYNC™ APPLICATIONS AND SERVICES

1. Press the **MENU** button to enter the system's menu.
2. Scroll to **SYNC-Apps**, and then press **OK**.

A list of available applications appears. Each application might have its own specific settings.

SYNC Emergency Assistance

WARNINGS



For this feature to work, your cell phone must have Bluetooth and be compatible with the system.



Always place your cell phone in a secure location inside your vehicle. Failure to do so may cause serious injury to someone or damage the cell phone which could prevent this feature from working correctly.

WARNINGS



Unless the feature setting is switched on prior to a crash, the system will not attempt to place an emergency call which could delay the response time, potentially increasing the risk of serious injury or death. Do not wait for the system to make an emergency call if you can do it yourself. Dial emergency services immediately to avoid a delayed response time. If you do not hear emergency assistance within five seconds of the crash, the system or cell phone may be damaged or non-functional.

Note: Before selecting this feature, you must read the emergency assistance privacy notice later in this section for important information.

Note: When you switch this feature on or off, that setting applies for all paired cell phones. If you have turned this feature off and a previously paired phone connects when you switch on the ignition, either a voice message plays, a display message or icon is shown or both.

Note: Every cell phone operates differently. While this feature works with most cell phones, some cell phones may experience difficulties using this feature.

Note: Make sure you are familiar with the information about airbag deployment. See **Supplementary Restraints System** (page 29).

If a crash deploys an airbag or triggers the fuel pump shut off, the system may contact emergency services by dialing 112 (the wireless emergency number that works in most European countries) through a paired and connected cell phone. For more information about the system and emergency assistance, visit the regional Ford website.

Switching Emergency Assistance On and Off

1. Press the **PHONE** button to enter the cell phone menu.
2. Select the emergency assistance option and press **OK**.
3. Select the option you require and press **OK**.

Display Options

If you switch on this feature, a confirmation message appears in the display.

If you switch off this feature, a dialog appears in the display, which allows you to set a voice reminder.

Off with voice reminder provides a display and voice reminder when your cell phone connects and your vehicle starts.

Off without voice reminder provides a display reminder only without a voice reminder when your cell phone connects.

To make sure that emergency assistance works correctly:

- The system must have power and be working correctly at the time of the crash and during feature activation and use.
- You must switch on the feature before a crash.
- You must have a cell phone connected to the system.
- In certain countries, it may be necessary to have a valid and registered SIM card with credit in order to place and maintain an emergency call.
- A connected cell phone must have the ability to make and maintain an outgoing call at the time of the crash.
- A connected cell phone must have adequate network coverage, battery power and signal strength.
- Your vehicle must have battery power.

Note: This feature only works in a European country or region where SYNC emergency assistance can call the local emergency services. Visit the regional Ford website for details.

In the Event of a Crash

Note: Not every crash deploys an airbag or triggers the fuel pump shut off (which may turn on emergency assistance). However, if emergency assistance is triggered the system tries to contact the emergency services. If a connected cell phone sustains damage or loses connection to the system, it searches for and tries to connect to any available previously paired cell phone. The system attempts to dial 112.

Before making a call:

- If you do not cancel the call and SYNC makes a successful call, an introductory message plays for the emergency operator. After this message, there is hands-free communication between your vehicle's occupants and the operator.
- The system provides a short window of time (approximately 10 seconds) to cancel the call. If you do not cancel the call, the system attempts to dial 112.
- The system plays a message letting you know when it attempts to make an emergency call. You can cancel the call by selecting the relevant icon in the display or by pressing the hang up button on your cell phone.

During a call:

- Emergency assistance uses your vehicle GPS or cellular network information when available to determine the most appropriate language to use. It alerts the emergency operator of the crash and delivers the introductory message. This may include your vehicle GPS coordinates.
- The language the system uses to interact with the occupants of your vehicle may differ from the language used to deliver information to the emergency operator.
- After the delivery of the introductory message the voice line opens so that you can speak hands-free with the emergency operator.
- When the line is connected, you must be prepared to provide your name, phone number and location information immediately.

Note: *While the system provides information to the emergency operator, the system plays a message letting you know it is sending important information. It then lets you know when the line is open to start hands-free communication.*

Note: *During an emergency assistance call, an emergency priority screen appears which contains vehicle GPS coordinates when available. These coordinates match the information provided to the emergency operator in the introductory message.*

Note: *The emergency operator may also receive information from the cellular network such as cell phone number, cell phone location and cell phone carrier name independent from SYNC emergency assistance.*

Emergency assistance may not work if:

- Your cell phone or emergency assistance hardware sustains damage in the crash.
- The vehicle battery or the system has no power.
- A crash ejects your cell phone from your vehicle.
- You do not have a valid and registered SIM card with credit in your cell phone.
- You are in a European country or region where the SYNC emergency assistance cannot place the call. Visit the regional Ford website for details.

Important Information about the Emergency Assistance Feature

Emergency assistance does not currently call emergency services in the following markets: Albania, Belarus, Bosnia and Herzegovina, Macedonia, Netherlands, Ukraine, Moldova and Russia.

Visit the regional Ford website for latest details.

Emergency Assistance Privacy Notice

When you switch on emergency assistance, it may disclose to emergency services that your vehicle has been in a crash involving the deployment of an airbag or activation of the fuel pump shut off. This feature has the capability to disclose your location information to the emergency operator or other details about your vehicle or crash to provide the most appropriate emergency services.

If you do not want to disclose this information, do not switch on the feature.

USING SYNC™ WITH YOUR MEDIA PLAYER

You can access and play music from your media player through your vehicle's speaker system using the system's media menu or voice commands. You can also sort and play your music by specific categories such as artist or albums.

SYNC is capable of hosting nearly any media player including: iPod, Zune, Plays from device players, and most USB drives. SYNC also supports audio formats such as MP3, WMA, WAV and ACC.

Connecting Your Media Player to the USB Port

Note: *If your media player has a power switch, make sure you switch on the device.*

To Connect Using Voice Commands

1. Plug the device into your vehicle's USB port.
2. Press the voice button and when prompted, say "USB".

3. You can now play music by saying any of the appropriate voice commands. Refer to the media voice commands.

To Connect Using the System Menu

1. Plug the device into your vehicle's USB port.
2. Press the **AUX** button until an initializing message appears in the display.
3. Depending on how many media files are on your connected device, an indexing message may appear in the display. When indexing is complete, the screen returns to the **Play** menu.

Press **Browse**. Now you can scroll through the list:

- **Play all.**
- **Playlists.**
- **Songs.**
- **Artists.**
- **Albums.**
- **Genres.**
- **Browse USB.**
- **Reset USB.**
- **Exit.**

What's Playing?

At any time during playback, you can press the voice button and ask the system what is playing. The system reads the metadata tags (if populated) of the current track.

Media Voice Commands



Press the voice button and when prompted say "USB", and then any of the following:

SYNC™

"USB"	
"Pause"	"Play track <name>" ^{1,2}
"Play"	"Repeat off"
"Play album <name>" ^{1,2}	"Repeat on"
"Play All"	"Search album <name>" ^{1,2}
"Play artist <name>" ^{1,2}	"Search artist <name>" ^{1,2}
"Play genre <name>" ^{1,2}	"Search genre <name>" ¹
"Play next folder" ³	"Search song <name>" ¹
"Play next track"	"Search track <name>" ^{1,2}
"Play playlist <name>" ^{1,2}	"Shuffle off"
"Play previous folder" ³	"Shuffle on"
"Play previous track"	"Similar music"
"Play song <name>" ¹	"What's playing?"

¹ <name> is a dynamic listing, meaning that it could be the name of anything such as desired group, artist or song.

² Voice commands that are not available until indexing is complete.

³ Voice commands that are only available in folder mode.

Voice command guide	
"Search genre" or "Play genre"	The system searches all the data from your indexed music and if available, begins to play the chosen type of music. You can only play genres of music that are present in the genre metadata tags that you have on your media player.
"Similar music"	The system compiles a playlist and then plays similar music to what is currently playing from the USB port using indexed metadata information.
Search or Play, "Artist", "Track, or "Album"	The system searches for a specific artist, track or album from the music indexed through the USB port.

SYNC™

The system is also capable of playing music from your cell phone via Bluetooth.

To switch on the Bluetooth audio, use the **AUX** or **Source** button or press the voice button. When prompted say, "Bluetooth audio", then any of the following:

"Bluetooth Audio"
"Connections"
"Pause"
"Play"
"Play next track"
"Play previous track"

Media Menu Features

The media menu allows you to select how to play your music (such as by artist, genre, shuffle or repeat) and to find similar music or reset the index of your USB devices.

1. Press **AUX** to select USB playback and then **Options** to enter the **Media** menu.
2. Scroll to cycle through:

When you select	You can
Shuffle playlist and Repeat track	Choose to shuffle or repeat your music. Once you make your choice, it remains on until you switch it off.
Similar music	You can play similar types of music to the current playlist from the USB port. The system uses the metadata information of each track to compile a playlist. The system then creates a new list of similar tracks and then begins playing. Each track must have the metadata tags populated for this feature. With certain playing devices, if your metadata tags are not populated, the tracks will not be available in voice recognition, play menu or similar music. However, if you place these tracks onto your playing device in mass storage device mode they are available in voice recognition, Play menu browsing and Similar Music. The system places Unknowns into any unpopulated metadata tag.
Reset SYNC USB	Resets the USB index. After the new indexing is complete you can choose what to play from the USB song library.

Accessing Your USB Song Library

This menu allows you to select and play your media files by artist, album, genre, playlist and track or even to browse what is on your USB device.

1. Make sure you plug your device into your vehicle's USB port and switch it on.

2. Press **AUX** to select USB playback and then **Browse**.

If there are no media files to access, the display indicates there is no media. If there are media files, you have the following options to scroll through and select:

When you select	You can
Play all	Play all indexed media files from your playing device one at a time in numerical order.* Press OK to select. The first track title appears in the display.
Playlists	Access your playlists (from formats such as .ASX, .M3U, .WPL or .MTP).* 1. Press OK to select. 2. Scroll to select the desired playlist, and then press OK .
Songs	Search for and play a specific indexed track.* 1. Press OK to select. 2. Scroll to select the desired track, and then press OK .
Artists	Sort all indexed media files by artist. Once selected, the system lists and then plays all artists and tracks alphabetically.* 1. Press OK to select. 2. Scroll to select the desired artist, and then press OK .
Albums	Sort all indexed media files by albums.* 1. Press OK to select. 2. Scroll to select the desired albums, and then press OK .
Genres	Sort indexed music by genre (category) type.* 1. Press OK to select. 2. Scroll to select the desired genre, and then press OK .
Browse USB	Browse all supported media files on your media player connected to the USB port. You can only view media files that are compatible with SYNC; other saved files are not visible. 1. Press OK to select.

SYNC™

When you select	You can
	2. Scroll to browse indexed media files on your flash drive, and then press OK .
Reset USB	Resets the USB index. After the new indexing is complete, you can choose what to play from the USB song library.

* You can use the buttons at the bottom of the audio display to jump to a certain alphabetical category quickly. You can also use the letters on the numeric keypad to jump in the list.

Bluetooth Devices and System Settings

You can access these menus using the audio display. See **Using SYNC™ With Your Phone** (page 241).

SYNC™ TROUBLESHOOTING

Your SYNC system is easy to use. However, should questions arise, please refer to the tables below.

To check your cell phone's compatibility, visit the regional Ford website.

Cell phone issues		
Issue	Possible cause	Possible solution
A lot of background noise during a phone call.	The audio control settings on your cell phone may be affecting SYNC performance.	Refer to your device's manual about audio adjustments.
During a call, I can hear the other person but they cannot hear me.	Possible cell phone malfunction.	Try switching off your cell phone, resetting it or removing the battery, then trying again.
		Make sure that the microphone for SYNC is not set to off.
SYNC is not able to download my phonebook.	Possible cell phone malfunction.	Check your cell phone's compatibility.
		Try switching off your cell phone, resetting it or removing the battery, then trying again.
		Try pushing your phonebook contacts to SYNC by selecting the option to add.
		You must switch on your cell phone and the automatic phonebook download feature on SYNC.

SYNC™

Cell phone issues		
Issue	Possible cause	Possible solution
The system says "Phonebook downloaded" but my SYNC phonebook is empty or is missing contacts.	Limitations on your cell phone's capability.	Try pushing your phonebook contacts to SYNC by selecting the option to add.
		If the missing contacts are stored on your SIM card, try moving them to your cell phone's memory.
		Remove any pictures or special ring tones associated with the missing contact.
		You must switch on your cell phone and the automatic phonebook download feature on SYNC.
I am having trouble connecting my cell phone to SYNC.	This is a cell phone-dependent feature.	Check your cell phone's compatibility.
	Possible cell phone malfunction.	Try switching off your cell phone, resetting it or removing the battery, then trying again.
		Try deleting your device from SYNC and deleting SYNC from your device, then trying again.
		Always check the security and auto accept prompt settings relative to the SYNC Bluetooth connection on your cell phone.
		Update your cell phone's firmware.
		Switch off the auto download setting.
Text messaging is not working on SYNC.	This is a cell phone-dependent feature.	Check your cell phone's compatibility.
	Possible cell phone malfunction.	Try switching off your cell phone, resetting it or removing the battery, then trying again.

SYNC™

Cell phone issues		
Issue	Possible cause	Possible solution
Audible text messages do not work on my cell phone.	This is a cell phone-dependent feature.	Your cell phone must support downloading text messages through Bluetooth to receive incoming text messages.
		Access the text messaging menu of SYNC to see if your cell phone supports the feature. Press the PHONE button and then scroll and select the option for text messaging, then press OK .
	This is a cell phone limitation.	Because each cell phone is different, refer to your device's manual for the specific cell phone you are pairing. In fact, there can be differences between cell phones due to brand, model, service provider and software version.

USB and media issues		
Issue	Possible cause	Possible solution
I am having trouble connecting my device.	Possible device malfunction.	Try switching off the device, resetting it or removing the battery, then trying again.
		Make sure you are using the manufacturer's cable.
		Make sure correctly insert the USB cable to the device and your vehicle's USB port.
		Make sure that the device does not have an auto-install program or active security settings.
SYNC does not recognize my device when I start my vehicle.	This is a device limitation.	Make sure you are not leaving the device in your vehicle during very hot or cold temperatures.
Bluetooth audio does not stream.	This is a device-dependent feature.	Make sure you connect the device to SYNC and press play on your device.
	The device is not connected.	

SYNC™

USB and media issues		
Issue	Possible cause	Possible solution
SYNC does not recognize music that is on my device.	Your music files may not contain the correct artist, song title, album or genre information.	Make sure that all song details are populated.
	The file may be corrupted.	Try replacing the corrupt file with a new version.
	The song may have copyright protection that does not allow it to play.	Some devices require you to change the USB settings from mass storage to media transfer protocol class.
When I connect my iPhone or iPod Touch through the USB and Bluetooth Audio at the same time, I sometimes do not hear any sound.	This is a device limitation.	From the iPhone or iPod Touch music now playing screen, select the audio device airplay icon at the very bottom of your iPhone or iPod Touch screen.
		To listen to the iPhone or iPod Touch through Bluetooth Audio, select SYNC.
		To listen to the iPhone or iPod Touch through USB, select Dock Connector.

Voice command issues		
Issue	Possible cause	Possible solution
SYNC does not understand what I am saying.	You may be using the wrong voice commands.	Review the cell phone voice commands and the media voice commands at the beginning of their respective sections.
		Refer to the audio display during an active voice session to find a list of voice commands there.
	You may be speaking too soon or at the wrong time.	The microphone for the system is either in your rear view mirror or in the headliner just above the windshield.
SYNC does not understand the name of a song or artist.	You may be using the wrong voice commands.	Review the media voice commands at the beginning of the media section.

Voice command issues		
Issue	Possible cause	Possible solution
	You may not be saying the name exactly as the system saved it.	Say the song or artist exactly as the system saved it. If you say, "Play Artist Prince", the system does not play music by Prince and the Revolution or Prince and the New Power Generation.
		Make sure you are saying the complete title such as "California remix featuring Jennifer Nettles".
		If the song titles are in capital letters, you have to spell them. LOLA requires you to say "L-O-L-A".
	The system may not be reading the name the same way you are saying it.	Do not use special characters in the title, as the system does not recognize them.
SYNC does not understand or is calling the wrong contact when I want to make a call.	You may be using the wrong voice commands.	Review the cell phone voice commands at the beginning of the cell phone section.
		You can also use the cell phone and media suggestion lists to get a list of possible suggestions when the system cannot fully understand you. See Using Voice Recognition (page 238).
	You may not be saying the name exactly as the system saved it.	Make sure you are saying the name exactly as the system saved it. For example, if the contact name is Joe Wilson, say "Call Joe Wilson".
		The system works better if you list full names such as "Joe Wilson" rather than "Joe".
	Contacts in your phonebook may be very short and similar or they may contain special characters.	Do not use special characters such as 123 or ICE as the system does not recognize them.
Your phonebook contacts may be in capital letters.	If the contacts are in capital letters, you have to spell them. JAKE requires you to say "Call J-A-K-E".	

SYNC™

Voice command issues		
Issue	Possible cause	Possible solution
The SYNC voice control system is having trouble recognizing foreign names stored on my cell phone.	You may be saying the foreign names using the currently selected language for SYNC.	SYNC applies the phonetic pronunciation rules of the selected language to the contact names stored on your cell phone.
		Helpful Hint: You can select your contact manually. Press PHONE . Select the option for phonebook and then contact name. Press the soft-key option to hear it. SYNC will read the contact name to you, giving you some idea of the pronunciation it is expecting.
The SYNC voice control system is having trouble recognizing foreign tracks, artists, albums, genres and playlist names from my media player or USB flash drive.	You may be saying the foreign names using the currently selected language for SYNC.	SYNC applies the phonetic pronunciation rules of the selected language to the names stored on your media player or USB flash drive. It is able to make some exceptions for very popular artist names (for example, U2) such that you can always use the English pronunciation for these artists.

SYNC™

Voice command issues		
Issue	Possible cause	Possible solution
The system generates voice prompts and the pronunciation of some words may not be accurate for my language.	SYNC uses text-to-speech voice prompt technology.	SYNC uses a synthetically generated voice rather than pre-recorded human voice.
		SYNC offers several new voice control features for a wide range of languages. Dialing a contact name directly from the phonebook without pre-recording (for example, "call John Smith") or selecting a track, artist, album, genre or playlist directly from your media player (for example, "play artist Madonna).
My previous Bluetooth voice control system allowed me to control the radio, CD, and climate control systems. Why can I not control these systems with SYNC?	The focus of SYNC is to control your mobile devices and the content stored on them.	SYNC offers significant capability beyond the previous system such as dialing a contact name directly from the phonebook without pre-recording (for example, "call John Smith") or selecting a track, artist, album, genre or playlist directly from your media player (for example, "play artist Madonna).

General		
Issue	Possible cause	Possible solution
The language selected for the instrument cluster and information and entertainment display does not match the SYNC language (phone, USB, Bluetooth audio, voice control and voice prompts).	SYNC does not support the currently selected language for the instrument cluster and information and entertainment display.	SYNC only supports four languages in a single module for text display, voice control and voice prompts. The country where you bought your vehicle dictates the four languages based on the most popular languages spoken. If the selected language is not available, SYNC remains in the current active language.
		SYNC offers several new voice control features for a wide range of languages. Dialing a contact name directly from the phonebook without pre-recording (for example, "call John Smith") or selecting a track, artist, album, genre or playlist directly from your media player (for example, play artist Madonna).

Appendices

ELECTROMAGNETIC COMPATIBILITY

WARNINGS

 Your vehicle has been tested and certified to legislation relating to electromagnetic compatibility (72/245/EEC, UN ECE Regulation 10 or other applicable local requirements). It is your responsibility to make sure that any equipment you have fitted complies with applicable local legislation. Have any equipment fitted by an authorized dealer.

 Radio frequency transmitter equipment (e.g. cell phones, amateur radio transmitters etc.) may only be fitted to your vehicle if they comply with the parameters shown in the table below. There are no special provisions or conditions for installations or use.

WARNINGS

 Do not mount any transceiver, microphones, speakers, or any other item in the deployment path of the airbag system.

 Do not fasten antenna cables to original vehicle wiring, fuel pipes and brake pipes.

 Keep antenna and power cables at least 4 inches (10 centimeters) from any electronic modules and airbags.

Note: *Only fit antennae in the positions shown to the roof of your vehicle.*

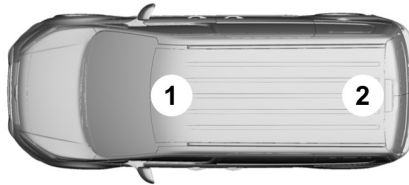

E164941

Frequency Band MHz	Maximum output power Watt (Peak RMS)	Antenna Positions
1 – 30	50 W	2
30 – 54	50 W	1, 2
68 – 87.5	50 W	1, 2
142 – 176	50 W	1, 2
380 – 512	50 W	1, 2

Appendices

Frequency Band MHz	Maximum output power Watt (Peak RMS)	Antenna Positions
806 – 940	10 W	1, 2
1200 – 1400	10 W	1, 2
1710 – 1885	10 W	1, 2
1885 – 2025	10 W	1, 2

Note: After the installation of radio frequency transmitters, check for disturbances from and to all electrical equipment in your vehicle, both in the standby and transmit modes.

Check all electrical equipment:

- with the ignition on
- with the engine running
- during a road test at various speeds.

Check that electromagnetic fields generated inside your vehicle cabin by the transmitter installed do not exceed applicable human exposure requirements.

END USER LICENSE AGREEMENT

SYNC® End User License Agreement (EULA)

- You have acquired a device ("DEVICE") that includes software licensed by Ford Motor Company and its affiliates ("FORD MOTOR COMPANY") from an affiliate of Microsoft Corporation ("MS"). Those installed software products of MS origin, as well as associated media, printed materials,

and "online" or electronic documentation ("MS SOFTWARE") are protected by international intellectual property laws and treaties. The MS SOFTWARE is licensed, not sold. All rights reserved.

- The MS SOFTWARE may interface with and/or communicate with, or may be later upgraded to interface with and/or communicate with additional software and/or systems provided by FORD MOTOR COMPANY. The additional software and systems of FORD MOTOR COMPANY origin, as well as associated media, printed materials, and "online" or electronic documentation ("FORD SOFTWARE") are protected by international intellectual property laws and treaties. The FORD SOFTWARE is licensed, not sold. All rights reserved.

Appendices

- The MS SOFTWARE and/or FORD SOFTWARE may interface with and/or communicate with, or may be later upgraded to interface with and/or communicate with additional software and/or systems provided by third party software and service suppliers. The additional software and services of third party origin, as well as associated media, printed materials, and "online" or electronic documentation ("THIRD PARTY SOFTWARE") are protected by international intellectual property laws and treaties. The THIRD PARTY SOFTWARE is licensed, not sold. All rights reserved.
- The MS SOFTWARE, FORD SOFTWARE and THIRD PARTY SOFTWARE hereinafter collectively and individually will be referred to as "SOFTWARE".

IF YOU DO NOT AGREE TO THIS END USER LICENSE AGREEMENT ("EULA") DO NOT USE THE DEVICE OR COPY THE SOFTWARE. ANY USE OF THE SOFTWARE, INCLUDING BUT NOT LIMITED TO USE ON THE DEVICE, WILL CONSTITUTE YOUR AGREEMENT TO THIS EULA (OR RATIFICATION OF ANY PREVIOUS CONSENT).

GRANT OF SOFTWARE LICENSE: This EULA grants you the following license:

- You may use the SOFTWARE as installed on the DEVICE and as otherwise interfacing with systems and/or services provide by or through FORD MOTOR COMPANY or its third party software and service providers.

Description of Other Rights and Limitations

- **Speech Recognition:** If the SOFTWARE includes speech recognition component(s), you should understand that speech recognition is an inherently statistical process and that recognition errors are inherent in the process. Neither FORD MOTOR COMPANY nor its suppliers shall be liable for any damages arising out of errors in the speech recognition process.
- **Limitations on Reverse Engineering, Decompilation and Disassembly:** You may not reverse engineer, decompile, or disassemble nor permit others to reverse engineer, decompile or disassemble the SOFTWARE, except and only to the extent that such activity is expressly permitted by applicable law notwithstanding this limitation.
- **Limitations on Distributing, Copying, Modifying and Creating Derivative Works:** You may not distribute, copy, make modifications to or create derivative works based on the SOFTWARE, except and only to the extent that such activity is expressly permitted by applicable law notwithstanding this limitation.
- **Single EULA:** The end user documentation for the DEVICE and related systems and services may contain multiple EULAs, such as multiple translations and/or multiple media versions (e.g., in the user documentation and in the software). Even if you receive multiple EULAs, you are licensed to use only one (1) copy of the SOFTWARE.

Appendices

- **SOFTWARE Transfer:** You may permanently transfer your rights under this EULA only as part of a sale or transfer of the DEVICE, provided you retain no copies, you transfer all of the SOFTWARE (including all component parts, the media and printed materials, any upgrades, and, if applicable, the Certificate(s) of Authenticity), and the recipient agrees to the terms of this EULA. If the SOFTWARE is an upgrade, any transfer must include all prior versions of the SOFTWARE.
- **Termination:** Without prejudice to any other rights, FORD MOTOR COMPANY or MS may terminate this EULA if you fail to comply with the terms and conditions of this EULA.
- **Security Updates/Digital Rights Management:** Content owners use the WMDRM technology included in your DEVICE to protect their intellectual property, included copyrighted content. Portions of the SOFTWARE on your DEVICE use WMDRM software to access WMDRM-protected content. If the WMDRM software fails to protect the content, content owners may ask Microsoft to revoke the SOFTWARE's ability to use WMDRM to play or copy protected content. This action does not affect unprotected content. When your DEVICE downloads licenses for protected content, you agree that Microsoft may include a revocation list with the licenses. Content owners may require you to upgrade the SOFTWARE on your DEVICE to access their content. If you decline an upgrade, you will not be able to access content that requires the upgrade.
- **Consent to Use of Data:** You agree that MS, Microsoft Corporation, FORD MOTOR COMPANY, third party software and systems suppliers, their affiliates and/or their designated agent may collect and use technical information gathered in any manner as part of product support services related to the SOFTWARE or related services. MS, Microsoft Corporation, FORD MOTOR COMPANY, third party software and services suppliers, their affiliates and/or their designated agent may use this information solely to improve their products or to provide customized services or technologies to you. MS, Microsoft Corporation, FORD MOTOR COMPANY, third party software and systems suppliers, their affiliates and/or their designated agent may disclose this information to others, but not in a form that personally identifies you.
- **Internet-Based Services Components:** The SOFTWARE may contain components that enable and facilitate the use of certain Internet-based services. You acknowledge and agree that MS, Microsoft Corporation, FORD MOTOR COMPANY, third party software and service suppliers, their affiliates and/or their designated agent may automatically check the version of the SOFTWARE and/or its components that you are utilizing and may provide upgrades or supplements to the SOFTWARE that may be automatically downloaded to your DEVICE.
- **Additional Software/Services:** The SOFTWARE may permit FORD MOTOR COMPANY, third party software and service suppliers, MS, Microsoft Corporation, their affiliates and/or their designated agent to provide or make available to you SOFTWARE updates,

Appendices

supplements, add-on components, or Internet-based services components of the SOFTWARE after the date you obtain your initial copy of the SOFTWARE ("Supplemental Components").

If FORD MOTOR COMPANY or third party software and services suppliers provide or make available to you Supplemental Components and no other EULA terms are provided along with the Supplemental Components, then the terms of this EULA shall apply.

If MS, Microsoft Corporation, their affiliates and/or their designated agent make available Supplemental Components, and no other EULA terms are provided, then the terms of this EULA shall apply, except that the MS, Microsoft Corporation or affiliate entity providing the Supplemental Component(s) shall be the licensor of the Supplemental Component(s).

FORD MOTOR COMPANY, MS, Microsoft Corporation, their affiliates and/or their designated agent reserve the right to discontinue without liability any Internet-based services provided to you or made available to you through the use of the SOFTWARE.

- **Links to Third Party Sites:** The MS SOFTWARE may provide you with the ability to link to third party sites through the use of the SOFTWARE. The third party sites are not under the control of MS, Microsoft Corporation, their affiliates and/or their designated agent. Neither MS nor Microsoft Corporation nor their affiliates nor their designated agent are responsible for (i) the contents of any third party sites, any links contained in third party sites, or any changes or updates to third party sites, or (ii) webcasting or any other form of transmission received from any third party sites. If the SOFTWARE provides links to third party sites, those links are provided to you only as a convenience, and the inclusion of any link does not imply an endorsement of the third party site by MS, Microsoft Corporation, their affiliates and/or their designated agent.
- **Obligation to Drive Responsibly:** You recognize your obligation to drive responsibly and keep attention on the road. You will read and abide with the DEVICE operating instructions particularly as they pertain to safety and assumes any risk associated with the use of the DEVICE.

UPGRADES AND RECOVERY MEDIA:

If the SOFTWARE is provided by FORD MOTOR COMPANY separate from the DEVICE on media such as a ROM chip, CD ROM disk(s) or via web download or other means, and is labeled "For Upgrade Purposes Only" or "For Recovery Purposes Only" you may install one (1) copy of such SOFTWARE onto the DEVICE as a replacement copy for the existing SOFTWARE, and use it in accordance with this EULA, including any additional EULA terms accompanying the upgrade SOFTWARE.

Appendices

INTELLECTUAL PROPERTY RIGHTS:

All title and intellectual property rights in and to the SOFTWARE (including but not limited to any images, photographs, animations, video, audio, music, text and "applets" incorporated into the SOFTWARE), the accompanying printed materials, and any copies of the SOFTWARE, are owned by MS, Microsoft Corporation, FORD MOTOR COMPANY, or their affiliates or suppliers. The SOFTWARE is licensed, not sold. You may not copy the printed materials accompanying the SOFTWARE. All title and intellectual property rights in and to the content which may be accessed through use of the SOFTWARE is the property of the respective content owner and may be protected by applicable copyright or other intellectual property laws and treaties. This EULA grants you no rights to use such content. All rights not specifically granted under this EULA are reserved by MS, Microsoft Corporation, FORD MOTOR COMPANY, third party software and service providers, their affiliates and suppliers. Use of any on-line services which may be accessed through the SOFTWARE may be governed by the respective terms of use relating to such services. If this SOFTWARE contains documentation that is provided only in electronic form, you may print one copy of such electronic documentation.

EXPORT RESTRICTIONS: You acknowledge that the SOFTWARE is subject to U.S. and European Union export jurisdiction. You agree to comply with all applicable international and national laws that apply to the SOFTWARE, including the U.S. Export Administration Regulations, as well as end-user, end-use and destination restrictions issued by U.S. and other governments. For additional information, see <http://www.microsoft.com/exporting/>.

TRADEMARKS: This EULA does not grant you any rights in connection with any trademarks or service marks of FORD MOTOR COMPANY, MS, Microsoft Corporation, third party software or service providers, their affiliates or suppliers.

PRODUCT SUPPORT: Product support for the SOFTWARE is not provided by MS, its parent corporation Microsoft Corporation, or their affiliates or subsidiaries. For product support, please refer to FORD MOTOR COMPANY instructions provided in the documentation for the DEVICE. Should you have any questions concerning this EULA, or if you desire to contact FORD MOTOR COMPANY for any other reason, please refer to the address provided in the documentation for the DEVICE.

No Liability for Certain Damages: EXCEPT AS PROHIBITED BY LAW, FORD MOTOR COMPANY, ANY THIRD PARTY SOFTWARE OR SERVICES SUPPLIERS, MS, MICROSOFT CORPORATION AND THEIR AFFILIATES SHALL HAVE NO LIABILITY FOR ANY INDIRECT, SPECIAL, CONSEQUENTIAL OR INCIDENTAL DAMAGES ARISING FROM OR IN CONNECTION WITH THE USE OR PERFORMANCE OF THE SOFTWARE. THIS LIMITATION SHALL APPLY EVEN IF ANY REMEDY FAILS OF ITS ESSENTIAL PURPOSE. IN NO EVENT SHALL MS, MICROSOFT CORPORATION AND/OR THEIR AFFILIATES BE LIABLE FOR ANY AMOUNT IN EXCESS OF U.S. TWO HUNDRED FIFTY DOLLARS (U.S. \$250.00).

- THERE ARE NO WARRANTIES OTHER THAN THOSE THAT MAY EXPRESSLY BE PROVIDED FOR YOUR NEW VEHICLE.

Appendices

Adobe

Contains Adobe® [Flash® Player] or [AIR®] technology by Adobe Systems Incorporated. This [Licensee Product] contains [Adobe® Flash® Player] [Adobe® AIR®] software under license from Adobe Systems Incorporated, Copyright ©1995-2009 Adobe Macromedia Software LLC. All rights reserved. Adobe, Flash and AIR are trademarks of Adobe Systems Incorporated.

End User Notice

Microsoft® Windows® Mobile for Automotive Important Safety Information

This system Ford SYNC™ contains software that is licensed to Manufacturer FORD MOTOR COMPANY by an affiliate of Microsoft Corporation pursuant to a license agreement. Any removal, reproduction, reverse engineering or other unauthorized use of the software from this system in violation of the license agreement is strictly prohibited and may subject you to legal action.

Read and follow instructions: Before using your Windows Automotive-based system, read and follow all instructions and safety information provided in this end user manual ("User's Guide"). Not following precautions found in this User's Guide can lead to an accident or other serious consequences.

Keep User's Guide in vehicle: When kept in the vehicle, the User's Guide will be a ready reference for you and other users unfamiliar with the Windows Automotive-based system. Please make certain that before using the system for the first time, all persons have access to the User's Guide and read its instructions and safety information carefully.

WARNING



Operating certain parts of this system while driving can distract your attention away from the road, and possibly cause an accident or other serious consequences. Do not change system settings or enter data non-verbally (using your hands) while driving. Stop the vehicle in a safe and legal manner before attempting these operations. This is important since while setting up or changing some functions you might be required to distract your attention away from the road and remove your hands from the wheel.

General Operation

Voice Command Control: Functions within the Windows Automotive-based system may be accomplished using only voice commands. Using voice commands while driving allows you to operate the system without removing your hands from the wheel.

Prolonged Views of Screen: Do not access any function requiring a prolonged view of the screen while you are driving. Pull over in a safe and legal manner before attempting to access a function of the system requiring prolonged attention. Even occasional short scans to the screen may be hazardous if your attention has been diverted away from your driving task at a critical time.

Volume Setting: Do not raise the volume excessively. Keep the volume at a level where you can still hear outside traffic and emergency signals while driving. Driving while unable to hear these sounds could cause an accident.

Appendices

Use of Speech Recognition Functions:

Speech recognition software is inherently a statistical process which is subject to errors. It is your responsibility to monitor any speech recognition functions included in the system and address any errors.

Navigation Features: Any navigation features included in the system are intended to provide turn by turn instructions to get you to a desired destination. Please make certain all persons using this system carefully read and follow instructions and safety information fully.

Distraction Hazard: Any navigation features may require manual (non-verbal) setup. Attempting to perform such set-up or insert data while driving can seriously distract your attention and could cause an accident or other serious consequences. Stop the vehicle in a safe and legal manner before attempting these operations.

Let Your Judgment Prevail: Any navigation features are provided only as an aid. Make your driving decisions based on your observations of local conditions and existing traffic regulations. Any such feature is not a substitute for your personal judgment. Any route suggestions made by this system should never replace any local traffic regulations or your personal judgment or knowledge of safe driving practices.

Route Safety: Do not follow the route suggestions if doing so would result in an unsafe or illegal maneuver, if you would be placed in an unsafe situation, or if you would be directed into an area that you consider unsafe. The driver is ultimately responsible for the safe operation of the vehicle and therefore, must evaluate whether it is safe to follow the suggested directions.

Potential Map Inaccuracy: Maps used by this system may be inaccurate because of changes in roads, traffic controls or driving conditions. Always use good judgment and common sense when following the suggested routes.

Emergency Services: Do not rely on any navigation features included in the system to route you to emergency services. Ask local authorities or an emergency services operator for these locations. Not all emergency services such as police, fire stations, hospitals and clinics are likely to be contained in the map database for such navigation features.

TeleNav Software End User License Agreement

Please read these terms and conditions carefully before you use the TeleNav Software. Your use of the TeleNav Software indicates that you accept these terms and conditions. If you do not accept these terms and conditions, do not break the seal of the package, launch, or otherwise use the TeleNav Software.

TeleNav may revise this Agreement and the privacy policy at any time, with or without notice to you. You agree to visit <http://www.telenav.com> from time to time to review the then current version of this Agreement and of the privacy policy.

1. Safe and Lawful Use

You acknowledge that devoting attention to the TeleNav Software may pose a risk of injury or death to you and others in situations that otherwise require your undivided attention, and you therefore agree to comply with the following when using the TeleNav Software: (a) observe all traffic laws and otherwise drive safely; (b) use your own personal judgment while driving. If you feel that a route suggested by the TeleNav Software instructs you to perform an unsafe or illegal maneuver,

Appendices

places you in an unsafe situation, or directs you into an area that you consider to be unsafe, do not follow such instructions; (c) do not input destinations, or otherwise manipulate the TeleNav Software, unless your vehicle is stationary and parked; (d) do not use the TeleNav Software for any illegal, unauthorized, unintended, unsafe, hazardous, or unlawful purposes, or in any manner inconsistent with this Agreement; (e) arrange all GPS and wireless devices and cables necessary for use of the TeleNav Software in a secure manner in your vehicle so that they will not interfere with your driving and will not prevent the operation of any safety device (such as an airbag).

You agree to indemnify and hold TeleNav harmless against all claims resulting from any dangerous or otherwise inappropriate use of the TeleNav Software in any moving vehicle, including as a result of your failure to comply with the directions above.

2. Account Information

You agree: (a) when registering the TeleNav Software, to provide TeleNav with true, accurate, current, and complete information about yourself, and (b) to inform TeleNav promptly of any changes to such information, and to keep it true, accurate, current and complete.

3. Software License

Subject to your compliance with the terms of this Agreement, TeleNav hereby grants to you a personal, non-exclusive, non-transferable license (except as expressly permitted below in connection with your permanent transfer of the TeleNav Software license), without the right to sublicense, to use the TeleNav Software (in object code form only) in order to access and use the TeleNav Software. This license shall terminate upon

any termination or expiration of this Agreement. You agree that you will use the TeleNav Software only for your personal business or leisure purposes, and not to provide commercial navigation services to other parties.

3.1 License Limitations

You agree not to do any of the following: (a) reverse engineer, decompile, disassemble, translate, modify, alter or otherwise change the TeleNav Software or any part thereof; (b) attempt to derive the source code, audio library or structure of the TeleNav Software without the prior express written consent of TeleNav; (c) remove from the TeleNav Software, or alter, any of TeleNav's or its suppliers' trademarks, trade names, logos, patent or copyright notices, or other notices or markings; (d) distribute, sublicense or otherwise transfer the TeleNav Software to others, except as part of your permanent transfer of the TeleNav Software; or (e) use the TeleNav Software in any manner that (i) infringes the intellectual property or proprietary rights, rights of publicity or privacy or other rights of any party, (ii) violates any law, statute, ordinance or regulation, including but not limited to laws and regulations related to spamming, privacy, consumer and child protection, obscenity or defamation, or (iii) is harmful, threatening, abusive, harassing, tortuous, defamatory, vulgar, obscene, libelous, or otherwise objectionable; and (f) lease, rent out, or otherwise permit unauthorized access by third parties to the TeleNav Software without advanced written permission of TeleNav.

Appendices

4. Disclaimers

To the fullest extent permissible pursuant to applicable law, in no event will TeleNav, its licensors and suppliers, or agents or employees of any of the foregoing, be liable for any decision made or action taken by you or anyone else in reliance on the information provided by the TeleNav Software. TeleNav also does not warrant the accuracy of the map or other data used for the TeleNav Software. Such data may not always reflect reality due to, among other things, road closures, construction, weather, new roads and other changing conditions. You are responsible for the entire risk arising out of your use of the TeleNav Software. For example but without limitation, you agree not to rely on the TeleNav Software for critical navigation in areas where the well-being or survival of you or others is dependent on the accuracy of navigation, as the maps or functionality of the TeleNav Software are not intended to support such high risk applications, especially in more remote geographical areas.

TELENAV EXPRESSLY DISCLAIMS AND EXCLUDES ALL WARRANTIES IN CONNECTION WITH THE TELENAV SOFTWARE, WHETHER STATUTORY, EXPRESS OR IMPLIED, INCLUDING ALL WARRANTIES WHICH MAY ARISE FROM COURSE OF DEALING, CUSTOM OR TRADE AND INCLUDING, BUT NOT LIMITED TO, THE IMPLIED WARRANTIES OF MERCHANTABILITY, FITNESS FOR A PARTICULAR PURPOSE AND NON-INFRINGEMENT OF THIRD PARTY RIGHTS WITH RESPECT TO THE TELENAV SOFTWARE. Certain jurisdictions do not permit the disclaimer of certain warranties, so this limitation may not apply to you.

5. Limitation of Liability

TO THE EXTENT PERMITTED UNDER APPLICABLE LAW, UNDER NO CIRCUMSTANCES SHALL TELENAV OR ITS LICENSORS AND SUPPLIERS BE LIABLE TO YOU OR TO ANY THIRD PARTY FOR ANY INDIRECT, INCIDENTAL, CONSEQUENTIAL, SPECIAL OR EXEMPLARY DAMAGES (INCLUDING IN EACH CASE, BUT NOT LIMITED TO, DAMAGES FOR THE INABILITY TO USE THE EQUIPMENT OR ACCESS DATA, LOSS OF DATA, LOSS OF BUSINESS, LOSS OF PROFITS, BUSINESS INTERRUPTION OR THE LIKE) ARISING OUT OF THE USE OF OR INABILITY TO USE THE TELENAV SOFTWARE, EVEN IF TELENAV HAS BEEN ADVISED OF THE POSSIBILITY OF SUCH DAMAGES.

NOTWITHSTANDING ANY DAMAGES THAT YOU MIGHT INCUR FOR ANY REASON WHATSOEVER (INCLUDING, WITHOUT LIMITATION, ALL DAMAGES REFERENCED HEREIN AND ALL DIRECT OR GENERAL DAMAGES IN CONTRACT, TORT (INCLUDING NEGLIGENCE) OR OTHERWISE), THE ENTIRE LIABILITY OF TELENAV AND OF ALL OF TELENAV'S SUPPLIERS SHALL BE LIMITED TO THE AMOUNT ACTUALLY PAID BY YOU FOR THE TELENAV SOFTWARE. SOME STATES AND/OR JURISDICTIONS DO NOT ALLOW THE EXCLUSION OR LIMITATION OF INCIDENTAL OR CONSEQUENTIAL DAMAGES, SO THE ABOVE LIMITATIONS OR EXCLUSIONS MAY NOT APPLY TO YOU.

6. Arbitration and Governing Law

You agree that any dispute, claim or controversy arising out of or relating to this Agreement or the TeleNav Software shall be settled by independent arbitration involving a neutral arbitrator and administered by the American Arbitration Association in the County of Santa Clara, California. The arbitrator shall apply the

Appendices

Commercial Arbitration Rules of the American Arbitration Association, and the judgment upon the award rendered by the arbitrator may be entered by any court having jurisdiction. Note that there is no judge or jury in an arbitration proceeding and the decision of the arbitrator shall be binding upon both parties. You expressly agree to waive your right to a jury trial.

This Agreement and performance hereunder will be governed by and construed in accordance with the laws of the State of California, without giving effect to its conflict of laws provisions. To the extent judicial action is necessary in connection with the binding arbitration, both TeleNav and you agree to submit to the exclusive jurisdiction of the courts of the County of Santa Clara, California. The United Nations Convention on Contracts for the International Sale of Goods shall not apply.

7. Assignment

You may not resell, assign, or transfer this Agreement or any of your rights or obligations, except in totality, in connection with your permanent transfer of the TeleNav Software, and expressly conditioned upon the new user of the TeleNav Software agreeing to be bound by the terms and conditions of this Agreement. Any such sale, assignment or transfer that is not expressly permitted under this paragraph will result in immediate termination of this Agreement, without liability to TeleNav, in which case you and all other parties shall immediately cease all use of the TeleNav Software. Notwithstanding the foregoing, TeleNav may assign this Agreement to any other party at any time without notice, provided the assignee remains bound by this Agreement.

8. Miscellaneous

8.1

This Agreement constitutes the entire agreement between TeleNav and you with respect to the subject matter hereof.

8.2

Except for the limited licenses expressly granted in this Agreement, TeleNav retains all right, title and interest in and to the TeleNav Software, including without limitation all related intellectual property rights. No licenses or other rights which are not expressly granted in this Agreement are intended to, or shall be, granted or conferred by implication, statute, inducement, estoppel or otherwise, and TeleNav and its suppliers and licensors hereby reserve all of their respective rights other than the licenses explicitly granted in this Agreement

8.3

By using the TeleNav Software, you consent to receive from TeleNav all communications, including notices, agreements, legally required disclosures or other information in connection with the TeleNav Software (collectively, "Notices") electronically. TeleNav may provide such Notices by posting them on TeleNav's Website or by downloading such Notices to your wireless device. If you desire to withdraw your consent to receive Notices electronically, you must discontinue your use of the TeleNav Software.

8.4

TeleNav's or your failure to require performance of any provision shall not affect that party's right to require performance at any time thereafter, nor shall a waiver of any breach or default of this Agreement constitute a waiver of any subsequent breach or default or a waiver of the provision itself.

Appendices

8.5

If any provision herein is held unenforceable, then such provision will be modified to reflect the intention of the parties, and the remaining provisions of this Agreement will remain in full force and effect

8.6

The headings in this Agreement are for convenience of reference only, will not be deemed to be a part of this Agreement, and will not be referred to in connection with the construction or interpretation of this Agreement. As used in this Agreement, the words "include" and "including" and variations thereof, will not be deemed to be terms of limitation, but rather will be deemed to be followed by the words "without limitation".

9. Other Vendors Terms and Conditions

The TeleNav Software utilizes map and other data licensed to TeleNav by third party vendors for the benefit of you and other end users. This Agreement includes end-user terms applicable to these companies (included at the end of this Agreement), and thus your use of the TeleNav Software is also subject to such terms. You agree to comply with the following additional terms and conditions, which are applicable to TeleNav's third party vendor licensors:

NavTeq End User License Agreement

END USER TERMS

The content provided ("Data") is licensed, not sold. By opening this package, or installing, copying, or otherwise using the Data, you agree to be bound by the terms of this agreement. If you do not agree to the terms of this agreement, you are not permitted to install, copy, use, resell or transfer the Data. If you wish to reject the terms of this agreement, and have not

installed, copied, or used the Data, you must contact your retailer or NAVTEQ North America, LLC ("NT") within thirty (30) days of purchase for a refund of your purchase price. To contact NT, please visit www.navteq.com.

The Data is provided for your personal, internal use only and may not be resold. It is protected by copyright, and is subject to the following terms (this "End User License Agreement") and conditions which are agreed to by you, on the one hand, and NAVTEQ North America, LLC ("NT") and its licensors (including their licensors and suppliers) on the other hand.

The Data for areas of Canada includes information taken with permission from Canadian authorities, including: © Her Majesty the Queen in Right of Canada, © Queen's Printer for Ontario, © Canada Post Corporation, GeoBase®.

NT holds a nonexclusive license from the United States Postal Service ® to publish and sell ZIP+4 ® information.

© United States Postal Service ® 2009. Prices are not established, controlled or approved by the United States Postal Service ® The following trademarks and registrations are owned by the USPS: United States Postal Service, USPS, and ZIP+4.

The Data for Mexico includes certain Data from Instituto Nacional de Estadística y Geografía.

TERMS AND CONDITIONS

License Limitations on Use: You agree that your license to use this Data is limited to and conditioned on use for solely personal, noncommercial purposes, and not for service bureau, timesharing or other similar purposes. Except as otherwise set forth herein, you agree not to otherwise

Appendices

reproduce, copy, modify, decompile, disassemble or reverse engineer any portion of this Data, and may not transfer or distribute it in any form, for any purpose, except to the extent permitted by mandatory laws.

License Limitations on Transfer: Your limited license does not allow transfer or resale of the Data, except on the condition that you may transfer the Data and all accompanying materials on a permanent basis if: (a) you retain no copies of the Data; (b) the recipient agrees to the terms of this End User License Agreement; and (c) you transfer the Data in the exact same form as you purchased it by physically transferring the original media (e.g., the CD-ROM or DVD you purchased), all original packaging, all Manuals and other documentation. Specifically, Multi-disc sets may only be transferred or sold as a complete set as provided to you and not as a subset thereof.

Additional License Limitations: Except where you have been specifically licensed to do so by NT in a separate written agreement, and without limiting the preceding paragraph, your license is conditioned on use of the Data as prescribed in this agreement, and you may not (a) use this Data with any products, systems, or applications installed or otherwise connected to or in communication with vehicles capable of vehicle navigation, positioning, dispatch, real time route guidance, fleet management or similar applications; or (b) with, or in communication with, including without limitation, cellular phones, palmtop and handheld computers, pagers, and personal digital assistants or PDAs.

WARNING



This Data may contain inaccurate or incomplete information due to the passage of time, changing circumstances, sources used and the nature of collecting comprehensive geographic Data, any of which may lead to incorrect results.

No Warranty: This Data is provided to you "as is", and you agree to use it at your own risk. NT and its licensors (and their licensors and suppliers) make no guarantees, representations or warranties of any kind, express or implied, arising by law or otherwise, including but not limited to, content, quality, accuracy, completeness, effectiveness, reliability, fitness for a particular purpose, usefulness, use or results to be obtained from this Data, or that the Data or server will be uninterrupted or error free.

Disclaimer of Warranty: NT AND ITS LICENSORS (INCLUDING THEIR LICENSORS AND SUPPLIERS) DISCLAIM ANY WARRANTIES, EXPRESS OR IMPLIED, OF QUALITY, PERFORMANCE, MERCHANTABILITY, FITNESS FOR A PARTICULAR PURPOSE OR NON-INFRINGEMENT. Some States, Territories and Countries do not allow certain warranty exclusions, so to that extent the above exclusion may not apply to you.

Disclaimer of Liability: NT AND ITS LICENSORS (INCLUDING THEIR LICENSORS AND SUPPLIERS) SHALL NOT BE LIABLE TO YOU IN RESPECT OF ANY CLAIM, DEMAND OR ACTION, IRRESPECTIVE OF THE NATURE OF THE CAUSE OF THE CLAIM, DEMAND OR ACTION ALLEGING ANY LOSS, INJURY OR DAMAGES, DIRECT OR INDIRECT, WHICH MAY RESULT FROM THE USE OR POSSESSION OF THIS DATA; OR FOR ANY LOSS OF PROFIT, REVENUE, CONTRACTS

Appendices

OR SAVINGS, OR ANY OTHER DIRECT, INDIRECT, INCIDENTAL, SPECIAL OR CONSEQUENTIAL DAMAGES ARISING OUT OF YOUR USE OF OR INABILITY TO USE THIS DATA, ANY DEFECT IN THIS DATA, OR THE BREACH OF THESE TERMS OR CONDITIONS, WHETHER IN AN ACTION IN CONTRACT OR TORT OR BASED ON A WARRANTY, EVEN IF NT OR ITS LICENSORS HAVE BEEN ADVISED OF THE POSSIBILITY OF SUCH DAMAGES. Some States, Territories and Countries do not allow certain liability exclusions or damages limitations, so to that extent the above may not apply to you.

Export Control: You agree not to export from anywhere any part of the Data or any direct product thereof except in compliance with, and with all licenses and approvals required under, applicable export laws, rules and regulations, including but not limited to the laws, rules and regulations administered by the Office of Foreign Assets Control of the U.S. Department of Commerce and the Bureau of Industry and Security of the U.S. Department of Commerce. To the extent that any such export laws, rules or regulations prohibit NT from complying with any of its obligations hereunder to deliver or distribute Data, such failure shall be excused and shall not constitute a breach of this Agreement.

Entire Agreement: These terms and conditions constitute the entire agreement between NT (and its licensors, including their licensors and suppliers) and you pertaining to the subject matter hereof, and supersedes in their entirety any and all written or oral agreements previously existing between us with respect to such subject matter.

Severability: You and NT agree that if any portion of this agreement is found illegal or unenforceable, that portion shall be severed and the remainder of the Agreement shall be given full force and effect.

Governing Law: The above terms and conditions shall be governed by the laws of the State of Illinois, without giving effect to (i) its conflict of laws provisions, or (ii) the United Nations Convention for Contracts for the International Sale of Goods, which is explicitly excluded. You agree to submit to the personal jurisdiction of the State of Illinois for any and all disputes, claims and actions arising from or in connection with the Data provided to you hereunder.

Government End Users: If the Data is being acquired by or on behalf of the United States government or any other entity seeking or applying rights similar to those customarily claimed by the United States government, this Data is a "commercial term" as that term is defined at 48 C.F.R. ("FAR") 2.101, is licensed in accordance with this End User License Agreement, and each copy of Data delivered or otherwise furnished shall be marked and embedded as appropriate with the following "Notice of Use", and be treated in accordance with such Notice:

NOTICE OF USE

CONTRACTOR
(MANUFACTURER/SUPPLIER)

NAME:

NAVTEQ

CONTRACTOR
(MANUFACTURER/SUPPLIER)

ADDRESS:

**425 West Randolph Street, Chicago, IL
60606.**

Appendices

This Data is a commercial item as defined in FAR 2.101

and is subject to the End User License Agreement under

which this Data was provided.

© 2011 NAVTEQ. All rights reserved.

If the Contracting Officer, federal government agency, or any federal official refuses to use the legend provided herein, the Contracting Officer, federal government agency, or any federal official must notify NAVTEQ prior to seeking additional or alternative rights in the Data.

Wi-Fi hotspot data provided by JiWire, © 2013 JiWire.

Gracenote® Copyright

CD and music-related data from Gracenote, Inc., copyright© 2000-2007 Gracenote. Gracenote Software, copyright © 2000-2007 Gracenote. This product and service may practice one or more of the following U.S. Patents #5,987,525, #6,061,680, #6,154,773, #6,161,132, #6,230,192, #6,230,207, #6.240,459, #6,330,593 and other patents issued or pending. Some services supplied under license from Open Globe, Inc. for U.S. Patent: #6,304,523.

Gracenote and CDDB are registered trademarks of Gracenote. The Gracenote logo and logotype, and the "Powered by Gracenote™" logo are trademarks of Gracenote.

Gracenote® End User License Agreement (EULA)

This device contains software from Gracenote, Inc. of 2000 Powell Street Emeryville, California 94608 ("Gracenote").

The software from Gracenote (the "Gracenote Software") enables this device to do disc and music file identification and obtain music-related information, including name, artist, track, and title information ("Gracenote Data") from online servers ("Gracenote Servers"), and to perform other functions. You may use Gracenote Data only by means of the intended End User functions of this device.

This device may contain content belonging to Gracenote's providers. If so, all of the restrictions set forth herein with respect to Gracenote Data shall also apply to such content and such content providers shall be entitled to all of the benefits and protections set forth herein that are available to Gracenote.

You agree that you will use the content from Gracenote ("Gracenote Content"), Gracenote Data, the Gracenote Software, and Gracenote Servers for your own personal, non-commercial use only. You agree not to assign, copy, transfer or transmit the Gracenote Content, Gracenote Software or any Gracenote Data (except in a Tag associated with a music file) to any third party. YOU AGREE NOT TO USE OR EXPLOIT GRACENOTE CONTENT, GRACENOTE DATA, THE GRACENOTE SOFTWARE, OR GRACENOTE SERVERS, EXCEPT AS EXPRESSLY PERMITTED HEREIN.

You agree that your non-exclusive licenses to use the Gracenote Content, Gracenote Data, the Gracenote Software, and Gracenote Servers will terminate if you violate these restrictions. If your licenses terminate, you agree to cease any and all use of the Gracenote Content, Gracenote Data, the Gracenote Software, and Gracenote Servers. Gracenote, respectively, reserve all rights in Gracenote Data, the Gracenote Software, and the Gracenote Servers and Gracenote Content, including all ownership rights. Under no circumstances will either Gracenote

Appendices

become liable for any payment to you for any information that you provide, including any copyrighted material or music file information. You agree that Gracenote may enforce its respective rights, collectively or separately, under this agreement against you, directly in each company's own name.

Gracenote uses a unique identifier to track queries for statistical purposes. The purpose of a randomly assigned numeric identifier is to allow Gracenote to count queries without knowing anything about who you are. For more information, see the web page at www.gracenote.com for the Gracenote Privacy Policy.

THE GRACENOTE SOFTWARE, EACH ITEM OF GRACENOTE DATA AND THE GRACENOTE CONTENT ARE LICENSED TO YOU "AS IS". NEITHER GRACENOTE MAKES ANY REPRESENTATIONS OR WARRANTIES, EXPRESS OR IMPLIED, REGARDING THE ACCURACY OF ANY GRACENOTE DATA FROM THE GRACENOTE SERVERS OR GRACENOTE CONTENT. GRACENOTE COLLECTIVELY AND SEPARATELY RESERVE THE RIGHT TO DELETE DATA AND/OR CONTENT FROM THE COMPANIES' RESPECTIVE SERVERS OR, IN THE CASE OF GRACENOTE, CHANGE DATA CATEGORIES FOR ANY CAUSE THAT GRACENOTE DEEMS SUFFICIENT. NO WARRANTY IS MADE THAT EITHER GRACENOTE CONTENT OR THE GRACENOTE SOFTWARE OR GRACENOTE SERVERS ARE ERROR-FREE OR THAT THE FUNCTIONING OF THE GRACENOTE SOFTWARE OR GRACENOTE SERVERS WILL BE UNINTERRUPTED. GRACENOTE IS NOT OBLIGATED TO PROVIDE YOU WITH ANY ENHANCED OR ADDITIONAL DATA TYPES THAT GRACENOTE MAY CHOOSE TO PROVIDE IN THE FUTURE AND IS FREE TO DISCONTINUE ITS ONLINE SERVICES AT ANY TIME. GRACENOTE DISCLAIMS ALL

WARRANTIES EXPRESS OR IMPLIED, INCLUDING, BUT NOT LIMITED TO, IMPLIED WARRANTIES OF MERCHANTABILITY, FITNESS FOR A PARTICULAR PURPOSE, TITLE, AND NON-INFRINGEMENT. NEITHER GRACENOTE WARRANTS THE RESULTS THAT WILL BE OBTAINED BY YOUR USE OF THE GRACENOTE SOFTWARE OR ANY GRACENOTE SERVER. IN NO CASE WILL GRACENOTE BE LIABLE FOR ANY CONSEQUENTIAL OR INCIDENTAL DAMAGES OR FOR ANY LOST PROFITS OR LOST REVENUES FOR ANY REASON WHATSOEVER.

© Gracenote 2007.

FCC ID: KMHSYNGC2

IC: 1422A-SYNGC2

This device complies with Part 15 of the FCC Rules and with RSS-210 of Industry Canada. Operation is subject to the following two conditions: (1) This device may not cause harmful interference, and (2) this device must accept any interference received, including interference that may cause undesired operation.

WARNING



Changes or modifications not expressly approved by the party responsible for compliance could void the user's authority to operate the equipment. The term "IC" before the radio certification number only signifies that Industry Canada technical specifications were met.

The antenna used for this transmitter must not be co-located or operating in conjunction with any other antenna or transmitter.

Index

A

- A/C
 - See: Climate Control.....73
- About This Manual.....7
 - Protecting the Environment.....7
- ABS
 - See: Brakes.....118
- ABS driving hints
 - See: Hints on Driving With Anti-Lock Brakes.....118
- Accessories
 - See: Replacement Parts Recommendation.....9
- Active City Stop.....130
 - Principle of Operation.....130
 - Switching the System Off and On.....131
- Adjusting the Steering Wheel.....44
- Air Conditioning
 - See: Climate Control.....73
- Air Vents.....73
 - Center Air Vents.....73
 - Side Air Vents.....74
- Alarm
 - See: Anti-Theft Alarm.....38
- Anti-Theft Alarm.....38
 - Alarm System.....38
 - Arming the Alarm.....40
 - Disarming the Alarm.....40
 - Full and Reduced Guard.....39
 - Triggering the Alarm.....39
- Appendices.....266
- At a Glance.....12
- Audible Warnings and Indicators - Vehicles With: Automatic Transmission.....62
 - Automatic Transmission Warning Chime.....62
 - Headlamps On Warning Chime.....62
 - Key in Ignition Warning Chime.....62
 - Parking Brake On Warning Chime.....62
- Audible Warnings and Indicators - Vehicles With: Manual Transmission.....62
 - Headlamps On Warning Chime.....62
 - Key in Ignition Warning Chime.....62
 - Parking Brake On Warning Chime.....62
- Audio Control.....44
 - Type 1.....45
 - Type 2.....45
- Audio System.....206
 - General Information.....206
- Audio Troubleshooting.....228
- Audio unit - Vehicles With:
 - AM/FM/CD/Digital Audio Broadcast (DAB) Radio/SYNC.....207
 - Alternative Frequencies.....211
 - Automatic Volume Control.....211
 - Autostore Control.....210
 - News Broadcasts.....211
 - Regional Mode.....212
 - Sound Button.....209
 - Station Preset Buttons.....210
 - Station Tuning Control.....210
 - Traffic Information Control.....210
 - Waveband Button.....209
- Audio unit - Vehicles With: AM/FM/Digital Audio Broadcast (DAB) Radio.....218
 - Alternative Frequencies.....221
 - Bluetooth Audio Streaming.....224
 - Declaration of Conformity.....224
 - iPod.....224
 - Making and Receiving Calls.....223
 - News Broadcasts.....221
 - Phone.....222
 - Phone Menu Options.....223
 - Regional Mode.....221
 - Set Button.....219
 - Station Preset Buttons.....220
 - Station Tuning Control.....220
 - Traffic Information Control.....220
 - USB.....223
 - Waveband Button.....220

Index

Audio unit - Vehicles With: Digital Audio Broadcast (DAB) Radio/Navigation System.....	212
Alternative Frequencies.....	217
Automatic Volume Control.....	216
Autostore Control.....	215
Digital Signal Processing.....	216
News Broadcasts.....	217
Regional Mode.....	217
Sound Button.....	214
Station Preset Buttons.....	215
Station Tuning Control.....	215
Traffic Information Control.....	215
Waveband Button.....	214
Autolamps.....	48
Automatic Climate Control.....	76
Mono Mode.....	77
Switching Mono Mode Back On.....	77
Switching Mono Mode Off.....	77
Temperature Control.....	77
Automatic Transmission.....	114
Emergency Park Position Release Lever.....	116
Hints on Driving with an Automatic Transmission.....	116
Selector Lever Positions.....	114
Sport Mode and Manual Shifting.....	115
Auto-Start-Stop.....	103
To Re-Start the Engine.....	104
To Stop the Engine.....	104
Using Start-Stop.....	103
Auto-Start-Stop - Base ECOLite.....	102
ECO System.....	102
To Restart the Engine.....	103
To Stop the Engine.....	103
Using Start-Stop.....	102
Autowipers.....	41
Auxiliary Heater.....	80
Fuel Operated Heater.....	83
Fuel Operated Parking Heater.....	80
Auxiliary Input Jack.....	227
Auxiliary Power Points.....	95
12 Volt DC Power Point.....	95
Location.....	95

B

Bonnet Lock	
See: Opening and Closing the Hood.....	158
Brake and Clutch Fluid Check.....	167
Brakes.....	118
General Information.....	118
Breaking-In.....	141
Brakes and Clutch.....	141
Engine.....	141
Tires.....	141
Bulb Specification Chart.....	174

C

Capacities and Specifications.....	201
Cargo Nets.....	133
Installing the Net.....	133
Removing the Net.....	134
Car Wash	
See: Cleaning the Exterior.....	182
Catalytic Converter.....	107
Driving with a Catalytic Converter.....	107
Center Console.....	96
Changing a Bulb.....	170
Central High Mounted Brake Lamp.....	173
Front Fog Lamps.....	172
Headlamp.....	170
Interior Lamps.....	173
License Plate Lamp.....	173
Rear Lamps.....	172
Side Direction Indicator.....	172
Changing a Fuse.....	146
Fuses.....	146
Changing a Road Wheel.....	192
Installing a Road Wheel.....	196
Jacking and Lifting Points.....	193
Lowering the Spare Wheel.....	194
Lug Nuts.....	192
Removing a Road Wheel.....	195
Removing the Wheel Trim.....	195
Stowing the Flat Tire.....	196
Vehicle Jack.....	192
Vehicles with a Spare Wheel.....	192
Changing the 12V Battery.....	168
Changing the Wiper Blades.....	168
Changing the Front Wiper Blades.....	168
Rear Window Wiper Blades.....	169

Index

Checking the Wiper Blades.....	168	Driving Through Water.....	142
Child Safety.....	18	DRL.....	142
Child Safety Locks.....	25	See: Daytime Running Lamps.....	50
Left-Hand Side.....	25	E	
Right-Hand Side.....	25	Economical Driving.....	141
Child Seat Positioning.....	22	Accessories.....	141
Cigar Lighter.....	95	Anticipation.....	141
Cleaning the Alloy Wheels.....	183	Efficient Speed.....	141
Cleaning the Exterior.....	182	Electrical Systems.....	141
Body Paintwork Preservation.....	182	Gear Shifting.....	141
Cleaning the Chrome Trim.....	182	Tire Pressures.....	141
Cleaning the Headlamps.....	182	Electromagnetic compatibility.....	266
Cleaning the Rear Window.....	182	End User License Agreement.....	267
Cleaning the Interior.....	183	SYNC® End User License Agreement (EULA).....	267
Instrument Cluster Screens, LCD Screens and Radio Screens.....	183	Engine Block Heater.....	100
Rear Windows.....	183	Using the Engine Block Heater.....	101
Safety Belts.....	183	Engine Coolant Check.....	167
Climate Control.....	73	Adding Engine Coolant.....	167
Principle of Operation.....	73	Engine Immobilizer See: Passive Anti-Theft System.....	38
Clock.....	67	Engine Oil Check.....	166
Type 1.....	67	Adding Engine Oil.....	167
Type 2.....	67	Engine Oil Dipstick - 1.0L EcoBoost (74kW/100PS).....	166
Cold Weather Precautions.....	142	Engine Oil Dipstick - 1.6L Duratorq-TDCi (DV) Diesel.....	166
Coolant Check See: Engine Coolant Check.....	167	Engine Oil Dipstick - 1.6L EcoBoost (110kW/150PS) - Sigma.....	166
Cornering Lamps.....	51	Event Data Recording See: Data Recording.....	10
Cruise Control.....	46	Exterior Mirrors.....	55
Principle of Operation.....	128	Fold Away Exterior Mirrors.....	56
Cruise control See: Using Cruise Control.....	128	Power Exterior Mirrors.....	55
Cup Holders.....	96	F	
D		Fastening the Safety Belts.....	26
Data Recording.....	10	Using Safety Belts During Pregnancy.....	27
Daytime Running Lamps.....	50	First Aid Kit.....	144
Diesel Particulate Filter.....	99	Flat Tire Inflation See: Temporary Mobility Kit.....	184
Regeneration.....	99	Floor Mats.....	142
Digital Audio.....	225		
.....	225		
Direction Indicators.....	52		
DPF See: Diesel Particulate Filter.....	99		
Driver Airbag.....	29		
.....	29		
Driving Aids.....	129		
Driving Hints.....	141		

Index

Fog Lamps - Front	
See: Front Fog Lamps.....	50
Fog Lamps - Rear	
See: Rear Fog Lamps.....	50
Folding Tray.....	96
Front Exterior Overview.....	12
Front Fog Lamps.....	50
Fuel and Refueling.....	105
Fuel Burning Heater	
See: Auxiliary Heater.....	80
Fuel Consumption Figures - 1.0L	
EcoBoost (74kW/100PS).....	110
Fuel Consumption Figures.....	110
Fuel Consumption Figures - 1.6L	
Duratorq-TDCi (55kW/75PS)/1.6L	
Duratorq-TDCi (70kW/95PS)	
(TZ).....	111
Fuel Consumption Figures.....	111
Fuel Consumption Figures - 1.6L	
Duratorq-TDCi (70kW/95PS) (TZ),	
Base ECOlite.....	112
Fuel Consumption Figures.....	112
Fuel Consumption Figures - 1.6L	
Duratorq-TDCi (85kW/115PS).....	113
Fuel Consumption Figures.....	113
Fuel Consumption Figures - 1.6L	
EcoBoost (110kW/150PS) - Sigma.....	111
Fuel Consumption Figures.....	111
Fuel Consumption.....	109
Calculating Fuel Economy.....	110
Filling the Tank.....	110
Fuel Quality - Diesel.....	106
Long-Term Storage.....	106
Fuel Quality - Gasoline.....	106
Long-Term Storage.....	106
Fuel Shutoff.....	144
Fuse Box Locations.....	146
Engine Compartment Fuse Box.....	146
Luggage Compartment Fuse Box.....	146
Passenger Compartment Fuse Box.....	146
Fuses.....	146
Fuse Specification Chart.....	148
Engine Compartment Fuse Box.....	148
Load Compartment Fuse Box.....	154
Passenger Compartment Fuse Box.....	152

G

Gauges.....	58
Engine Coolant Temperature Gauge.....	58
Fuel Gauge.....	59
Information Display.....	58
General Information on Radio	
Frequencies.....	32
Global Opening and Closing.....	56
Global Closing.....	57
Global Opening.....	56

H

Handbrake	
See: Parking Brake.....	118
Hazard Warning Flashers.....	144
Headlamp Exit Delay.....	49
Headlamp Leveling.....	50
Head Restraints.....	84
.....	84
Adjusting the Head Restraints.....	84
Removing the Head Restraints.....	85
Heated Seats.....	93
Heated Windows and Mirrors.....	79
Heated Exterior Mirrors.....	80
Heated Rear Window.....	80
Heated Windshield.....	80
Heating	
See: Climate Control.....	73
Hill Start Assist - Vehicles With:	
Automatic Transmission.....	119
Using Hill Start Assist.....	119
Hill Start Assist - Vehicles With: Manual	
Transmission.....	119
Switching the System On and Off.....	120
Using Hill Start Assist.....	120

Index

Hints on Controlling the Interior	
Climate.....	77
Cooling the Interior Quickly.....	78
General Hints.....	77
Heating the Interior Quickly.....	78
Maximum Cooling Performance in Instrument Panel or Instrument Panel and Footwell Positions.....	78
Recommended Settings for Cooling	78
Recommended Settings for Heating.....	78
Side Window Defogging in Cold Weather.....	78
Vehicle Stationary for Extended Periods During Extreme High Ambient Temperatures.....	78
Hints on Driving With Anti-Lock Brakes.....	118
Hood Lock See: Opening and Closing the Hood.....	158
I	
Ignition Switch.....	97
Information Display Control.....	46
Information Displays.....	63
General Information.....	63
Information Messages.....	68
Installing Child Seats.....	18
Attaching a Child Seat With a Support Leg.....	21
Attaching a Child Seat With Top Tethers.....	21
Booster Seats.....	19
Child Seats for Different Mass Groups.....	19
ISOFIX Anchor Points.....	20
Instrument Cluster.....	58
Instrument Lighting Dimmer.....	49
Instrument Panel Overview - Vehicles With: LHD.....	15
Instrument Panel Overview - Vehicles With: RHD.....	16
Interior Lamps.....	52
Courtesy Lamp.....	52
Luggage Compartment Lamp.....	52
Reading Lamps.....	52
Interior Mirror.....	56
Auto-Dimming Mirror.....	56
Introduction.....	7
J	
Jump-Starting the Vehicle.....	144
To Connect the Booster Cables.....	145
To Start the Engine.....	145
K	
Keys and Remote Controls.....	32
L	
Lighting Control.....	47
Headlamp Flasher.....	48
High Beams.....	48
Home Safe Lighting.....	48
Lighting Control Positions.....	47
Parking Lamps.....	47
Lighting.....	47
General Information.....	47
Load Carriers See: Roof Racks and Load Carriers.....	134
Load Carrying.....	132
General Information.....	132
Locking and Unlocking.....	34
Automatic Locking.....	35
Automatic Re-Locking.....	36
Automatic Unlocking.....	36
Configurable Unlocking.....	37
Double Locking.....	34
Locking.....	34
Locking and Unlocking Confirmation.....	34
Locking and Unlocking the Doors From Inside.....	34
Locking the Doors Individually With the Key.....	35
One-Stage Unlocking.....	36
Opening the Double Rear Doors.....	35
Opening the Sliding Door.....	35
Two-Stage Unlocking.....	36
Unlocking.....	34
Zone Re-Locking.....	36
Locks.....	34
Luggage Anchor Points.....	133
Lug Nuts See: Changing a Road Wheel.....	192

Index

M			
Maintenance.....	158		
General Information.....	158		
Technical Specifications - 1.0L EcoBoost (74kW/100PS).....	176		
Technical Specifications - 1.6L Duratorq-TDCi (DV) Diesel.....	178		
Technical Specifications - 1.6L EcoBoost (110kW/150PS) - Sigma.....	179		
Manual Climate Control.....	74		
Manual Liftgate.....	37		
Opening and Closing the Liftgate.....	37		
Manual Seats.....	85		
Adjusting the Height of the Driver Seat.....	86		
Adjusting the Lumbar Support.....	86		
Dual Passenger Seat.....	87		
Moving the Seat Backward and Forward.....	85		
Recline Adjustment.....	86		
Single Passenger Seat.....	86		
Manual Transmission - Vehicles With: 5-Speed Manual Transmission.....	114		
Selecting Reverse Gear.....	114		
Manual Transmission - Vehicles With: 6-Speed Manual Transmission.....	114		
Selecting Reverse Gear.....	114		
Media Hub.....	228		
Message Center See: Information Displays.....	63		
Mirrors See: Heated Windows and Mirrors.....	79		
See: Windows and Mirrors.....	53		
Mobile Communications Equipment.....	10		
		N	
		Navigation.....	229
		Hazard Spot Warning.....	236
		Information.....	233
		Loading Map Data.....	229
		Menu Structure.....	230
		Navigation Map Updates.....	236
		Road Safety.....	229
		Route Options.....	232
		Setting Your Navigation Preferences.....	233
		Type Approvals.....	236
		O	
		Oil Check See: Engine Oil Check.....	166
		Opening and Closing the Hood.....	158
		Closing the Hood.....	159
		Opening the Hood.....	158
		Overhead Console.....	96
		P	
		Parking Aid.....	123
		Front and Rear Sensing System.....	124
		Rear Sensing System.....	124
		Parking Aids.....	123
		Principle of Operation.....	123
		Parking Brake.....	118
		Passenger Airbag.....	30
		Switching the Passenger Airbag Off.....	30
		Switching the Passenger Airbag On.....	31
		Passive Anti-Theft System.....	38
		Arming the Engine Immobilizer.....	38
		Coded Keys.....	38
		Disarming the Engine Immobilizer.....	38
		Principle of Operation.....	38
		PATS See: Passive Anti-Theft System.....	38
		Personalized Settings.....	67
		Measure Units.....	67
		Switching Chimes Off.....	67
		Power Door Locks See: Locking and Unlocking.....	34

Index

Power Windows - Vehicles With:	
One-Touch Down Driver Window.....	53
Accessory Delay.....	53
One-Touch Down.....	53
Power Windows - Vehicles With: Rear	
Power Windows.....	53
Accessory Delay.....	55
Bounce-Back.....	54
One-Touch Down.....	54
One-Touch Up.....	54
Window Lock.....	54
R	
Rear Exterior Overview.....	13
Rear Fog Lamps.....	50
Rear Passenger Climate Controls.....	79
Rear Seat Armrest.....	94
Rear Seats.....	89
Vehicles With Five Seats.....	89
Vehicles With Seven Seats.....	91
Rear Under Floor Storage.....	132
Adjustable Load Floor.....	133
Cargo Management System.....	132
Passenger Compartment Floor.....	132
Rear View Camera.....	125
.....	126
Switching the Rear View Camera Off.....	127
Switching the Rear View Camera On.....	126
Using the Display.....	126
Vehicles with Parking Aid.....	127
Rear View Camera	
See: Rear View Camera.....	125
Rear Window Wiper and Washers.....	43
Rear Window Washer.....	43
Rear Window Wiper.....	43
Reduced Engine Performance.....	141
Refueling.....	108
Filling a Fuel Container.....	109
Remote Control.....	32
Changing the Remote Control Battery.....	32
Reprogramming the Unlocking	
Function.....	32
Repairing Minor Paint Damage.....	182
Replacement Parts	
Recommendation.....	9
Collision Repairs.....	9
Scheduled Maintenance and Mechanical	
Repairs.....	9
Warranty on Replacement Parts.....	10
Replacing a Lost Key or Remote	
Control.....	33
Roadside Emergencies.....	144
Roof Racks and Load Carriers.....	134
Maximum Load Weights.....	135
Running-In	
See: Breaking-In.....	141
Running Out of Fuel.....	106
Refilling With a Portable Fuel	
Container.....	107
S	
Safety Belt Height Adjustment.....	27
Safety Belt Minder.....	28
Turning the Safety Belt Minder Off.....	28
Safety Belts.....	26
Safety Precautions.....	105
Seats.....	84
Security.....	38
Side Airbags.....	31
Side Curtain Airbags.....	31
Sitting in the Correct Position.....	84
Snow Chains	
See: Using Snow Chains.....	188
Speed Control	
See: Cruise Control.....	128
Speed Limiter.....	129
Principle of Operation.....	129
Using the System.....	129
Stability Control.....	122
Principle of Operation.....	122
Starter Switch	
See: Ignition Switch.....	97
Starting a Diesel Engine.....	99
Cold or Hot Engine.....	99
Failure to Start.....	99
Starting a Gasoline Engine - Vehicles	
With: Automatic Transmission.....	98
Cold or Hot Engine.....	98
Engine Idle Speed after Starting.....	99
Flooded Engine.....	99

Index

Starting a Gasoline Engine - Vehicles	
With: Manual Transmission.....	98
Cold or Hot Engine.....	98
Engine Idle Speed after Starting.....	98
Failure to Start.....	98
Flooded Engine.....	98
Starting and Stopping the Engine.....	97
General Information.....	97
Steering Wheel Lock.....	97
Steering Wheel.....	44
Storage Compartments.....	96
Supplementary Restraints System.....	29
Principle of Operation.....	29
Switching Off the Engine.....	100
Vehicles With a Turbocharger.....	100
Symbols Glossary.....	7
SYNC™ Applications and Services.....	251
In the Event of a Crash.....	252
Switching Emergency Assistance On and Off.....	252
SYNC Emergency Assistance.....	251
SYNC™.....	237
General Information.....	237
SYNC™ Troubleshooting.....	258
T	
Tailgate	
See: Manual Liftgate.....	37
Technical Specifications	
See: Capacities and Specifications.....	201
Temporary Mobility Kit.....	184
Checking the Tire Pressure.....	187
General Information.....	184
Inflating the Tire.....	185
Using the Kit.....	184
Tire Care.....	188
Tire Inflation When Punctured	
See: Temporary Mobility Kit.....	184
Tire Pressure Monitoring System.....	189
Changing Tires With a Tire Pressure Monitoring System.....	189
How Temperature Affects the Tire Pressures.....	191
Tire Pressure Monitoring System Reset Procedure.....	191
Understanding the Tire Pressure Monitoring System.....	190
Tire Repair Kit	
See: Temporary Mobility Kit.....	184
Tires	
See: Wheels and Tires.....	184
Towbar Dimensions.....	203
Towing a Trailer.....	136
Trailer Lighting.....	137
When towing a trailer.....	136
Towing Points.....	137
Towing the Vehicle on Four Wheels - Vehicles With: Automatic Transmission.....	138
Emergency Towing.....	138
Towing the Vehicle on Four Wheels - Vehicles With: Manual Transmission.....	139
Towing.....	136
Traction Control.....	121
Principle of Operation.....	121
Trailer Sway Control.....	137
Transmission.....	114
Transmission	
See: Transmission.....	114
Transporting the Vehicle.....	139
Trip Computer.....	67
Average Fuel.....	67
Distance to Empty.....	67
Resetting the Trip Computer.....	67
Trip Odometer.....	67
U	
Under Hood Overview - 1.0L EcoBoost (74kW/100PS), Vehicles With: LHD.....	160
Under Hood Overview - 1.0L EcoBoost (74kW/100PS), Vehicles With: RHD.....	161
Under Hood Overview - 1.6L Duratorq-TDCi (DV) Diesel, Vehicles With: LHD.....	164
Under Hood Overview - 1.6L Duratorq-TDCi (DV) Diesel, Vehicles With: RHD.....	165
Under Hood Overview - 1.6L EcoBoost (110kW/150PS) - Sigma, Vehicles With: LHD.....	162

Index

Under Hood Overview - 1.6L EcoBoost (110kW/150PS) - Sigma, Vehicles With: RHD.....	163
Unique Driving Characteristics.....	102
USB Port.....	227
Using Cruise Control.....	128
Switching Cruise Control Off.....	128
Switching Cruise Control On.....	128
Using Snow Chains.....	188
Vehicles with Stability Control.....	188
Using Stability Control.....	122
Switching the System Off and On Using the Information Display Controls.....	122
Switching the System Off Using a Switch.....	122
Using SYNC™ With Your Media Player.....	254
Accessing Your USB Song Library.....	257
Bluetooth Devices and System Settings.....	258
Connecting Your Media Player to the USB Port.....	254
Media Menu Features.....	256
Media Voice Commands.....	254
What's Playing?.....	254
Using SYNC™ With Your Phone.....	241
Accessing Features through the Cell Phone Menu.....	245
Accessing Your Cell Phone Settings.....	247
Bluetooth Devices.....	249
Cell Phone Options during an Active Call.....	244
Cell Phone Voice Commands.....	242
Making a Call.....	244
Pairing a Cell Phone for the First Time.....	241
Pairing Subsequent Cell Phones.....	241
Receiving a Call.....	244
Text Messaging.....	246
Using Traction Control.....	121
Switching the System Off and On Using the Information Display Controls.....	121
Switching the System Off Using a Switch.....	121
Using Voice Recognition.....	238
Helpful Hints.....	238
Initiating a Voice Session.....	239
System Interaction and Feedback.....	239
Using Winter Tires.....	188
V	
Vehicle Care.....	182
Vehicle Dimensions - Vehicles With: Long Wheelbase Double Cab in Van/Long Wheelbase Van.....	201
Vehicle Dimensions.....	201
Vehicle Dimensions - Vehicles With: Long Wheelbase Kombi.....	201
Vehicle Dimensions.....	201
Vehicle Dimensions - Vehicles With: Short Wheelbase Double Cab in Van/Short Wheelbase Van.....	202
Vehicle Dimensions.....	202
Vehicle Dimensions - Vehicles With: Short Wheelbase Kombi.....	202
Vehicle Dimensions.....	202
Vehicle Identification Number.....	205
Vehicle Identification Plate.....	204
Vehicle Interior Overview.....	14
Ventilation See: Climate Control.....	73
Vents See: Air Vents.....	73
VIN See: Vehicle Identification Number.....	205
Voice Control.....	46

Index

W

Warning Lamps and Indicators.....	59
Anti-Lock Braking System Warning Lamp.....	59
Battery Warning Lamp.....	59
Brake System Warning Lamp.....	59
Cruise Control Indicator.....	59
Direction Indicator.....	59
Engine Oil Warning Lamp.....	60
Engine Warning Lamps.....	60
Fasten Safety Belt Warning Lamp.....	60
Front Airbag Warning Lamp.....	60
Front Fog Lamps Indicator.....	60
Frost Warning Lamp.....	60
Glow Plug Indicator.....	61
Headlamp and Parking Lamp Indicator.....	61
High Beam Indicator.....	61
Information Indicator.....	61
Low Fuel Level Warning Lamp.....	61
Rear Fog Lamps Indicator.....	61
Shift Indicator.....	61
Stability Control Off Indicator.....	61
Stability Control Warning Lamp.....	61
Start-Stop Indicator.....	61
Warning Triangle.....	144
Washer Fluid Check.....	168
Washers See: Cleaning the Exterior.....	182
See: Wipers and Washers.....	41
Wheel Nuts See: Changing a Road Wheel.....	192
Wheels and Tires.....	184
General Information.....	184
Technical Specifications - Vehicles With: Long Wheelbase Double Cab in Van.....	200
Technical Specifications - Vehicles With: Long Wheelbase Kombi.....	197
Technical Specifications - Vehicles With: Long Wheelbase Van.....	199
Technical Specifications - Vehicles With: Short Wheelbase Double Cab in Van.....	199
Technical Specifications - Vehicles With: Short Wheelbase Kombi.....	197
Technical Specifications - Vehicles With: Short Wheelbase Van.....	198
Windows and Mirrors.....	53
Windshield Washers.....	42
Windshield Wipers.....	41
Intermittent Wipe.....	41
Speed dependent wipers (if equipped).....	41
Winter Tires See: Using Winter Tires.....	188
Wipers and Washers.....	41

