

2021



Mustang Mach-E

# MODIFIER'S GUIDE



## SECTION 0: Introduction

---

### Table of Contents

Contents	PAGE
Introduction .....	0-2
Genuine Ford Accessories For Your Vehicle .....	0-2
Considerations When Using or Installing Accessories .....	0-2

# Introduction

## Introduction

### NOTE:

**Please note this manual does not apply to battery electric responder vehicles for upfitting. For battery electric responder vehicles please refer to the Responder Modifiers Guide.**

Ford Motor Company has assembled this guide to assist vehicle modifiers in producing a safe and quality vehicle. Ford believes safety and quality come first. To achieve customer satisfaction, we want to assist modifiers in achieving the highest standards of safety and quality in their vehicles.

This book is divided into topics pertinent to vehicle modifiers. References are made to the current Workshop Manual for appropriate service procedures, torque specifications, component separation clearances and other standard information which is common with an unmodified vehicle. Specifications unique to this guide are designated.

This modifier guide is not a "how-to" book; it should be used as a checklist to help make sure that certain important steps in the modification process are considered. While Ford is providing this information to assist modifiers, it does not warrant the vehicles, methods, materials or the workmanship of the modifier. Ford also does not warrant against failures that result from the modification of a vehicle.

Following the guidelines contained in this guide does not assure individual modifiers that the products they modify comply with US Federal or Canadian Motor Vehicle Safety Standards in effect at the time of the modification. The guidelines set forth are based on engineering analysis of typical vehicles. If the guidelines are followed, the modifier's efforts in certifying vehicles to applicable standards should be aided. Compliance testing that may be required for certification of specific vehicle configurations or construction is the sole responsibility of the individual modifier.

## Genuine Ford Accessories For Your Vehicle

A wide selection of genuine Ford accessories are available for your vehicle through your local authorized Ford or Ford of Canada dealer. These quality accessories have been specifically engineered to fulfill your automotive needs; they are custom designed to complement the style and aerodynamic appearance of your vehicle. In addition, each accessory is made from high-quality materials that meet or exceed Ford's rigorous engineering and safety specifications. Ford Motor Company will repair or replace any properly installed genuine Ford accessory found to be defective in factory-supplied materials or workmanship during the warranty period, as well as any component damaged by the defective accessory. The accessory will be warranted for whichever provides you the greatest benefit:

- 12 months or 20,000 km (12,000 mi), whichever occurs first; or
- the remainder of your new vehicle limited warranty.

This means that genuine Ford accessories purchased along with your new vehicle and installed by the dealer are covered for the full length of your new vehicle's limited warranty — 3 years or 60,000 km (36,000 mi), whichever occurs first. Contact your dealer for details and a copy of the warranty.

## Considerations When Using or Installing Accessories

For maximum vehicle performance, keep the following information in mind when adding accessories or equipment to your vehicle:

- When adding accessories, equipment, passengers and/or luggage to your vehicle, do not exceed the gross vehicle weight rating (GVWR) or gross axle weight rating (GAWR) as indicated on the Safety Compliance Certification Label. Consult your dealer for specific weight information.
- The Federal Communications Commission (FCC) and Canadian Radio Telecommunications Commission (CRTC) regulates the use of mobile communication systems, such as 2-way radios, telephones and theft alarms that are equipped with radio transmitters. Any such equipment installed in your vehicle should comply with FCC or CRTC regulations and should only be installed by a qualified service technician.
- Mobile communication systems may harm the operation of your vehicle, particularly if they are not properly designed for automotive use.
- To avoid interference with other vehicle functions, such as the anti-lock brake system (ABS), amateur radio users who install radios and antennas onto their vehicle should not locate the antenna in the area of the driver's side hood.
- Electrical or electronic accessories or components that are added to the vehicle by the dealer or the owner may adversely affect battery performance and durability.

## SECTION 1: General Information

---

### Table of Contents

Contents	PAGE
Section 1: General Information .....	1-2
Important Safety Notice .....	1-2
Good Practices .....	1-3
New Vehicle Storage .....	1-3
Tires and Loading .....	1-4
Ambient Temperature Change and Tire Pressure .....	1-6
Ride Height Measurement — Front .....	1-7
Ride Height Measurement — Rear .....	1-9
Ride Height Specifications .....	1-10

## Section 1: General Information

### Section 1: General Information

#### Important Safety Notice

**NOTE:**

The descriptions and specifications contained in this guide were in effect at the time this guide was approved for printing. Ford Motor Company reserves the right to discontinue models at any time, or change specifications or design without notice and without incurring obligation.

Appropriate repair methods and procedures are essential for the safe, reliable operation of all motor vehicles as well as the personal safety of the individual doing the work. This guide provides general direction and guidelines for performing modifications to the vehicle, which will help assure reliability.

There are numerous variations in procedures, techniques, tools and parts for modifying vehicles, as well as in the skill level of the individual doing the work. This guide cannot possibly anticipate all such variations and provide advice or cautions as to each. Accordingly, anyone who departs from the instructions provided in this guide must first establish that they compromise neither their personal safety nor the vehicle integrity by the choice of methods, tools or parts.

#### Warnings, Notices and Notes

As you read through this guide, you will come across WARNINGS, NOTICES and NOTES. Each one is there for a specific purpose. WARNINGS remind you to be especially careful in those areas where carelessness can cause you personal injury. NOTICES are given to prevent you from making an error that could damage the vehicle or the vehicle's components. NOTES give you added information that will help you to complete a particular procedure. The following list contains some generalized warnings that you should follow when working on a vehicle.

**WARNING:**

- The nominal High Voltage Traction Battery (HVTB) voltage is approximately up to 450 Volts DC. The HVTB and charging system contain high voltage components and wiring. High voltage cables and wiring are orange in color. Before carrying out any vehicle modifications, the HVTB must be depowered. Any modification, service, or repairs to the high voltage system or its components, must be done by a trained service technician. Failure to follow these instructions may result in severe personal injury or death.
- If applicable, make sure vehicle is not on plug in charging.
- For eye protection, always wear safety glasses.
- Use safety stands whenever a procedure requires you to be under the vehicle.
- Make sure the ignition switch is always in the OFF position, unless otherwise required by the procedure.
- Make sure the key fob is removed from the vehicle and is kept at least 3 meters (9.8 feet) away from the vehicle.
- Set the parking brake when working on the vehicle. The gear selector should be set in PARK unless instructed otherwise for a specific operation. Place wheel chocks against the front and rear surfaces of the tires to help prevent the vehicle from moving.
- Do not smoke while working on a vehicle.
- To reduce the risk of injury, always remove rings, watches, loose hanging jewelry and loose clothing before working on a vehicle.
- When it is necessary to work under the hood, keep hands and other objects clear of the cooling fan blades.
- Failure to follow these instructions may result in personal injury or death.

**NOTICE:**

- Do not modify the cooling system. High voltage vehicle components may be damaged if any cooling system modifications are attempted.
- Before placing the vehicle in a paint booth, make sure that the HVTB is not installed in the vehicle. In addition, the Charge Status Indicator (CSI) must be covered / protected from heat. High paint booth temperatures may damage the HVTB and the CSI.
- Depower the High Voltage system before carrying out any vehicle modifications.
- Make sure the 12 volt battery negative cable is disconnected.

#### Making Safety Devices and Elements Inoperative

The vehicle contains many safety features required by US Federal or Canadian Motor Vehicle Safety Standards. These features, which include the key-on-ignition chime and brake lights, should never be disabled or modified.

## Section 1: General Information

- Make sure the pedestrian alert sound system is not disabled.

CFR 49 Section 30122 states that "A manufacturer, distributor, dealer or motor vehicle repair business may not knowingly make inoperative any part of a device or element of design installed on or in a motor vehicle or motor vehicle's equipment in compliance with an applicable motor vehicle safety standard prescribed under this chapter unless the manufacturer, distributor, dealer or repair business reasonably believes the vehicle or equipment will not be used (except for testing or a similar purpose during maintenance or repair) when the device or element is inoperative."

### Good Practices

#### Process and Quality Assurance Systems

A formalized Process and Quality Assurance Systems check may be helpful in consistently producing high-quality products. An overview of some of the key items for such a system are outlined in this section.

#### Quality Assurance

Completed unit sign-off: All control items should be inspected with a written sign-off. All labels should be inspected and signed off, including verification that the information on the labels is correct. All appropriate systems should be checked for leaks. A road test should be performed to verify that all systems are operating correctly. All systems and functions that were provided by Ford should be checked to make sure that they function correctly after the build process.

The modifier's Process and Quality Assurance Systems should also make sure that appropriate training is provided to the employees.

#### Minimum and Maximum Screw Sizes

When installing aftermarket equipment, avoid using fasteners that are too long for the application or are in an area which might damage vehicle components, including the low voltage wiring, the high voltage system including the HVTB and the (orange) high voltage wiring/cables, brake lines, fuel tank and lines, powertrain components, exhaust system or suspension.

#### New Vehicle Storage

##### New Vehicle Storage — General

- Vehicle should be stored in a dry, ventilated place, and protected from sunlight, if possible.
- If vehicle is stored outside, maintenance against rust and damage, as described below, is recommended.

**NOTICE:**

Keep all rubber parts free from oil and solvents.

##### New Vehicle Storage — Body

- Wash vehicle thoroughly to remove dirt, grease, oil, tar or mud from exterior surfaces and underside of front fender.
- Periodically wash if vehicle is stored in exposed locations.
- Touch up exposed raw or primed metal to provide rust protection.
- Cover chrome and stainless steel parts with a thick coat of auto wax to prevent discoloration. Rewax as necessary when the vehicle is washed.
- Lubricate all hood, door hinges and latches with a light grade oil.
- Cover the interior soft trim to prevent fading.

##### New Vehicle Storage — Tires

The following steps should be taken to avoid flat spotting when the vehicle is not used for a period of time.

- Keep the vehicles tire pressure at the recommended operating pressure.
- If the vehicle is stored for a period longer than 15 days, it should be moved several feet during each 15-day period. The vehicle should be parked after being moved so that a different portion of the tread contacts the ground.

##### Vehicle Storage — Electrical

**NOTICE:**

If your vehicle is to be stored for 30 days or longer, the low voltage (trunk) battery negative terminal must be disconnected. Failure to do this could damage the battery.

## Section 1: General Information

**NOTE:**

Extended storage time which results in the discharge of the low and/or high voltage batteries, may result in the setting of Diagnostic Trouble Codes (DTCs) and/or a no-start condition.

To maintain the high voltage battery, once a month the vehicle's high voltage battery should be charged. This will maintain the high voltage battery, but may not be enough to maintain the 12v (low voltage) battery. Additional low voltage battery charging may be required after 60 days.

- For BEV Vehicles, the vehicle should be started and driven to maintain high voltage battery charge.

### Tires and Loading

#### Tire Replacement Requirements

**WARNING:**

Only use replacement tires and wheels that are the same size and type (such as P-metric versus LT-metric or all-season versus all-terrain) as those originally provided by Ford. Use of any tire or wheel not recommended by Ford can affect the safety and performance of your vehicle, which could result in an increased risk of the loss of vehicle control, vehicle rollover, personal injury or death. Additionally, the use of non-recommended tires and wheels could cause steering or suspension failure. If you have questions regarding tire replacement, see an authorized Ford or Lincoln dealer.

**NOTICE:**

Do not install an off road, aggressive tread or incorrectly sized tire. Any of these may cause elevated stress to the steering system. This can cause the power steering system to overheat and shut off the power assist, which can affect the safety and performance of your vehicle.

**NOTE:**

Vehicles are equipped with a reduced rolling resistance tire design. The use of a different tire can affect the travel distance of the vehicle as well as the vehicle's fuel economy.

Make sure all tires and wheels on the vehicle are of the same size, type, tread design, brand, load-carrying capacity and speed rating because it can affect the safety and performance of your vehicle, which could result in an increased risk of loss of vehicle control.

#### Tire Pressure Monitoring System (TPMS) Principles of Operation

The TPMS monitors the tire pressure using 4 valve stem mounted TPMS sensors to provide accurate tire pressures. Each individual sensor contains its own battery and transmits tire pressure data to the controlling module every 60 seconds when the vehicle speed exceeds 32 km/h (20 mph). The TPM module is a radio receiver that collects the tire pressure data and relays the information via the MS-CAN to the BCM. All of the TPMS functions are controlled by the BCM. The TPMS sensors are trained to the BCM, which records each TPMS sensors unique identifier. The BCM records where each TPMS sensor is located based on the training order and compares the actual tire pressure with the desired tire pressure as indicated on the Vehicle Certification label. If the tire pressure deviates from the desired tire pressure the BCM, using the HS-CAN, signals the IPC to illuminate the TPMS warning indicator and also displays a message on the message center. The programmed tire pressure cannot be changed.

This vehicle, as delivered by Ford Motor Company, conforms to Standard FMVSS138, Tire Pressure Monitoring Systems.

This system may not function if any of the following components are removed, relocated or modified in any way:

- Original Equipment Manufacturer (OEM) wheels and tires
- Tire pressure sensors or valve stems
- Body Control Module (BCM)
- BCM software and calibrations
- Tire Pressure Module (TPM)
- Instrument Cluster (IC) module
- IC software and calibrations
- Vehicle wheelbase longer than originally released

## Section 1: General Information

Certain modification could cause reduced system performance, up to and including the complete loss of TPM system functionality. This may include:

- Non-OEM wheels or tires
- The addition of steel carcass or run-flat tires
- Modification of the vehicle recommended tire pressure
- Lengthening of the vehicle wheelbase may affect signal strength of the sensors to a point where the rear sensors can no longer be heard by the TPM module. (Vehicles certified at released wheelbases only)
- The addition of metallic structures may affect the signal strength of the sensors and could interfere or prevent the TPM module from hearing the rear sensors.
- The addition of intended or unintended transmitters to the vehicle may affect the signal strength of the sensors or interfere with the TPM module's antenna

The TPM system as delivered from the Ford Motor Company, complies with part 15 of the FCC rules and with RS-210 of Industry Canada. Operation is subject to the following 2 conditions:

- This device may not cause harmful interference, and
- This device must accept any interference received, including interference that may cause undesired operation.

### Using Snow Tires and Traction Devices

#### NOTE:

Snow tires must be the same size and grade as originally equipped on your vehicle.

The tires on your vehicle have all-weather tread to provide traction in the rain and snow; however, in some climates, using snow tires or traction devices may be necessary.

Follow these guidelines when using snow tires and traction devices:

- SAE Class "S" cables should ONLY be used on the vehicle front tires.
- Install cables or chains securely, verifying that the cables or chains do not touch any wiring or brake lines.
- Drive cautiously! If you hear the cables or chains rub or bang against the vehicle, stop and retighten them. If this does not work, remove the cables or chains to prevent vehicle damage.
- Avoid overloading your vehicle.
- Remove the cables or chains when they are no longer needed. Do not use cables or chains on dry roads.
- Do not exceed 48 km/h (30 mph) with tire cables or chains on your vehicle.

Consult your dealer for information on other Ford approved methods of traction control.

### Vehicle Loading



#### WARNING:

The appropriate loading capacity of your vehicle can be limited either by volume capacity (how much space is available) or by payload capacity (how much weight the vehicle should carry). Once you have reached the maximum payload of your vehicle, do not add more cargo, even if there is space available. Overloading or improperly loading your vehicle can contribute to the loss of vehicle control and vehicle rollover.



#### WARNING:

Exceeding the Safety Compliance Certification Label axle and/or vehicle weight rating limits could result in substandard vehicle handling or performance, engine, transmission and/or structural damage, serious damage to the vehicle, loss of control and personal injury.

Gross vehicle weight rating (GVWR) is the maximum allowable weight of the fully loaded vehicle (including all options, equipment, passengers and cargo). The GVWR is shown on the Safety Compliance Certification Label located on the B-pillar or the edge of the driver's door.

Gross axle weight rating (GAWR) is the maximum allowable weight that can be carried by a single axle (front or rear). These numbers are shown on the Safety Compliance Certification Label located on the B-pillar or the edge of the driver's door. The total load on each axle must never exceed its GAWR.

## Section 1: General Information

### **WARNING:**

**Do not use replacement tires with lower load carrying capacities than the original tires because they may lower the vehicle's gross vehicle weight rating (GVWR) and gross axle weight rating (GAWR) limitations. Replacement tires with a higher limit than the originals do not increase the GVWR and GAWR limitations.**

Steps for determining the correct load limit:

- Locate the statement "The combined weight of occupants and cargo should never exceed XXX kg or XXX lb" on your vehicle's placard.
- Determine the combined weight of the driver and passengers that will be riding in your vehicle.
- Subtract the combined weight of the driver and passengers from XXX kg or XXX lb.
- The resulting figure equals the available amount of cargo and luggage load capacity. For example, if the "XXX" amount equals 1,400 lb and there will be five 150 lb passengers in your vehicle, the amount of available cargo and luggage load capacity is 650 lb (1400 - 750 (5 x 150) = 650 lb). In metric units (635 - 340 (5 x 68) = 295 kg).
- Determine the combined weight of luggage and cargo being loaded on the vehicle. That weight may not safely exceed the available cargo and luggage load capacity calculated in the step above.

### **Ambient Temperature Change and Tire Pressure**

#### **NOTICE:**

**Do not inflate tire higher than maximum pressure stamped on tire sidewall. Premature tire wear or damage to the tire may result.**

Tire pressures fluctuate with temperature changes. For this reason, tire pressure must be set to specification when tires are at outdoor ambient temperatures. If the vehicle is allowed to warm up to shop temperatures, and the outside temperature is less than shop temperature, the tire inflation pressure must be adjusted accordingly.

If the tires are inflated to specification at shop temperatures, and the vehicle is moved outdoors when the outdoor ambient temperature is significantly lower, the tire pressure may drop enough to be detected by the TPM system and activate the TPM system warning lamp.

As the ambient temperature decreases by 6°C (10°F), tire pressure decreases 7 kPa (1 psi). Adjust the tire pressure by 7 kPa (1 psi) for each 6°C (10°F) ambient temperature drop as necessary to keep the tire at the specified vehicle certification label pressure. Refer to the following tables to adjust the tire pressure indoors for colder outside temperatures.

## Section 1: General Information

**Table 1. Use Table to Adjust Tire Pressure Inside Garage for Colder Outside Temperature<sup>1</sup>**

**\*\* Do Not Inflate Tire Higher than Maximum Pressure Stamped on Tire Sidewall. \*\***

Table is based on a Garage Temperature of 70°F. Max Pressure Adjustment is 7 psi.																		
Outside Temperature (°F)	Tire Placard Pressure (PSI)																	
	30	32	34	35	38	40	41	42	45	50	55	60	65	70	75	80	85	90
70	30	32	34	35	38	40	41	42	45	50	55	60	65	70	75	80	85	90
60	31	33	35	36	39	41	42	43	46	51	56	61	67	72	77	82	87	92
50	32	34	36	37	40	42	43	44	47	53	58	63	68	73	79	84	89	94
40	33	35	37	38	41	43	44	45	49	54	59	64	70	75	80	86	91	96
30	34	36	38	39	42	44	46	47	50	55	61	66	72	77	82	87	92	97
20	35	37	39	40	43	46	47	48	51	57	62	67	72	77	82	87	92	97
10	36	38	40	41	45	47	48	49	52	57	62	67	72	77	82	87	92	97
0	37	39	41	42	45	47	48	49	52	57	62	67	72	77	82	87	92	97
-10	37	39	41	42	45	47	48	49	52	57	62	67	72	77	82	87	92	97
-20	37	39	41	42	45	47	48	49	52	57	62	67	72	77	82	87	92	97
-30	37	39	41	42	45	47	48	49	52	57	62	67	72	77	82	87	92	97
-40	37	39	41	42	45	47	48	49	52	57	62	67	72	77	82	87	92	97

**Table 2. Use Table to Adjust Tire Pressure Inside Garage for Colder Outside Temperature (Metric Units)<sup>1</sup>**

**\*\* Do Not Inflate Tire Higher than Maximum Pressure Stamped on Tire Sidewall. \*\***

Table is based on a Garage Temperature of 21°C. Max Pressure Adjustment is 50 kPa.																		
Outside Temperature (°C)	Tire Placard Pressure (kPa)																	
	205	220	235	240	260	275	285	290	310	345	380	415	450	485	515	550	585	620
21	205	220	235	240	260	275	285	290	310	345	380	415	450	485	515	550	585	620
16	215	230	240	250	270	285	290	295	315	350	385	420	460	495	530	565	600	635
10	220	235	250	255	275	290	295	305	325	365	400	435	470	505	545	580	615	650
4	230	240	255	260	285	295	305	310	340	370	405	440	485	515	550	595	625	660
-1	235	250	260	270	290	305	315	325	345	380	420	455	495	530	565	600	635	670
-7	240	255	270	275	295	315	325	330	350	395	425	460	495	530	565	600	635	670
-12	250	260	275	285	310	325	330	340	360	395	425	460	495	530	565	600	635	670
-18	255	270	285	290	310	325	330	340	360	395	425	460	495	530	565	600	635	670
-23	255	270	285	290	310	325	330	340	360	395	425	460	495	530	565	600	635	670
-29	255	270	285	290	310	325	330	340	360	395	425	460	495	530	565	600	635	670
-34	255	270	285	290	310	325	330	340	360	395	425	460	495	530	565	600	635	670
-40	255	270	285	290	310	325	330	340	360	395	425	460	495	530	565	600	635	670

<sup>1</sup>When Outside (Ambient) Temperature is greater than 21°C (70°F), Inflate tires to placard pressure.

<sup>1</sup>Use the table to adjust tire pressure for P-metric and LT tires only.

N0072166

### Ride Height Measurement — Front

1. **NOTE:**

Make sure that the vehicle is positioned on a flat, level surface and the tires are inflated to the correct pressure. Vehicle should have a full tank of fuel.

Jounce front and rear suspension vigorously to allow the vehicle to settle.

2. Before measuring ride height check:

- a. Tires are inflated to the correct pressure.
- b. Vehicle should have a full tank of fuel.
- c. All fluids at proper levels.
- d. No cargo inside the cab or bed.

## Section 1: General Information

- e. Inspect for aftermarket equipment. Check for aftermarket changes to the steering, suspension, wheel and tire components (such as competition, heavy duty, etc.).
3. Ride height = 3-2 (Use the General Equipment: Surface Gauge)

Measure the distance between the flat level surface and the center of the lower arm forward bolt. (measurement 2)  
 Measure the distance between the flat level surface and the center of the ball joint pinch bolt. (measurement 3)

Use the General Equipment: Surface Gauge

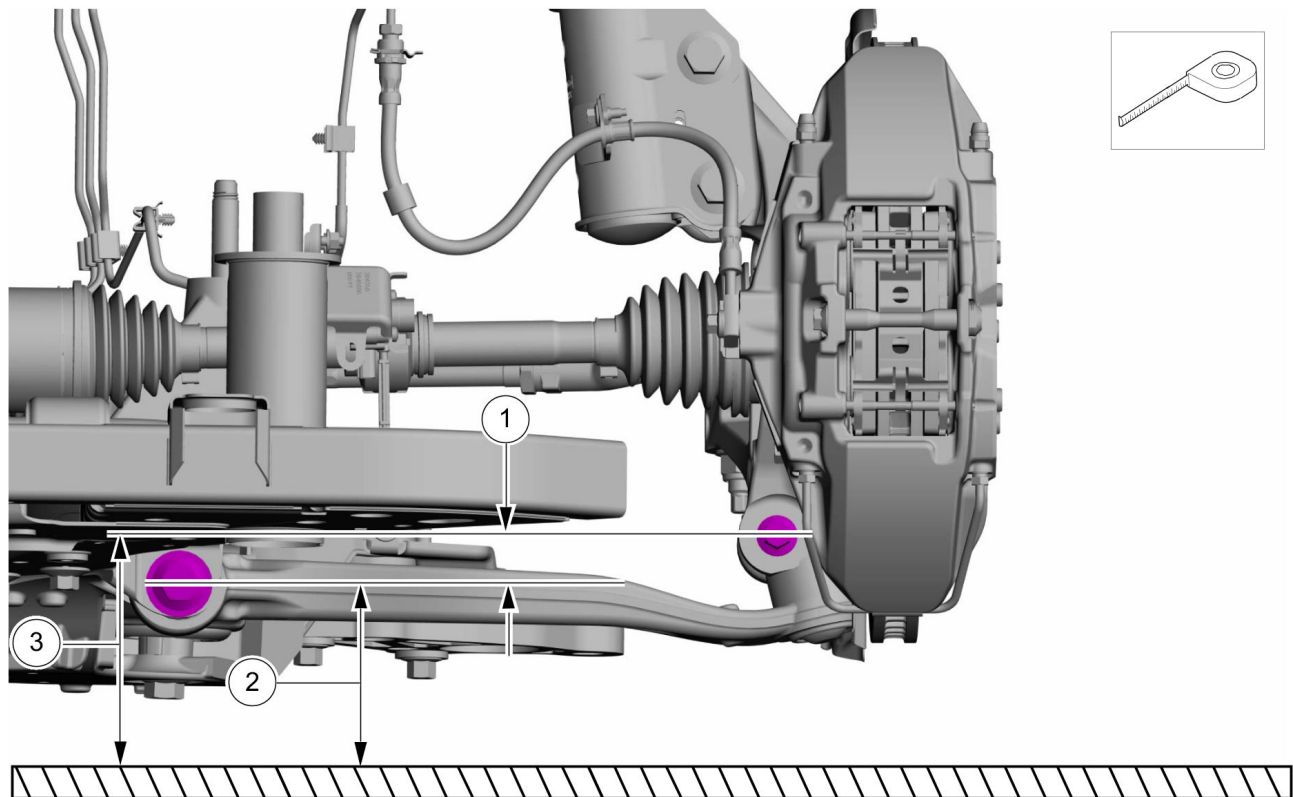

E344424

4. With the surface gauge positioned on a flat, level surface, record the measurement of the surface gauge position (measurement 2) and (measurement 3).

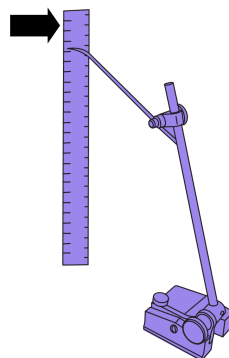

E145760

5. Subtract measurement 2 from measurement 3 to obtain the front ride height.

## Section 1: General Information

### Ride Height Measurement — Rear

1. **NOTE:**  
Make sure that the vehicle is positioned on a flat, level surface, transmission in the PARK position and the parking brake OFF.  
  
Jounce front and rear suspension vigorously to allow the vehicle to settle.
2. Before measuring ride height check:
  - a. Tires are inflated to the correct pressure.
  - b. Vehicle should have at least one-half tank of fuel.
  - c. All fluids at proper levels.
  - d. No cargo inside the cab or bed.
  - e. Inspect for aftermarket equipment. Check for aftermarket changes to the steering, suspension, wheel and tire components (such as competition, heavy duty, etc.).
3. Ride height = 2–3 (Use the General Equipment: Surface Gauge)
  - Measure the distance between the flat level surface and the center of the toe link inboard cam bolt. (measurement 2)
  - Measure the distance between the flat level surface and the center of the toe link outboard bolt. (measurement 3)

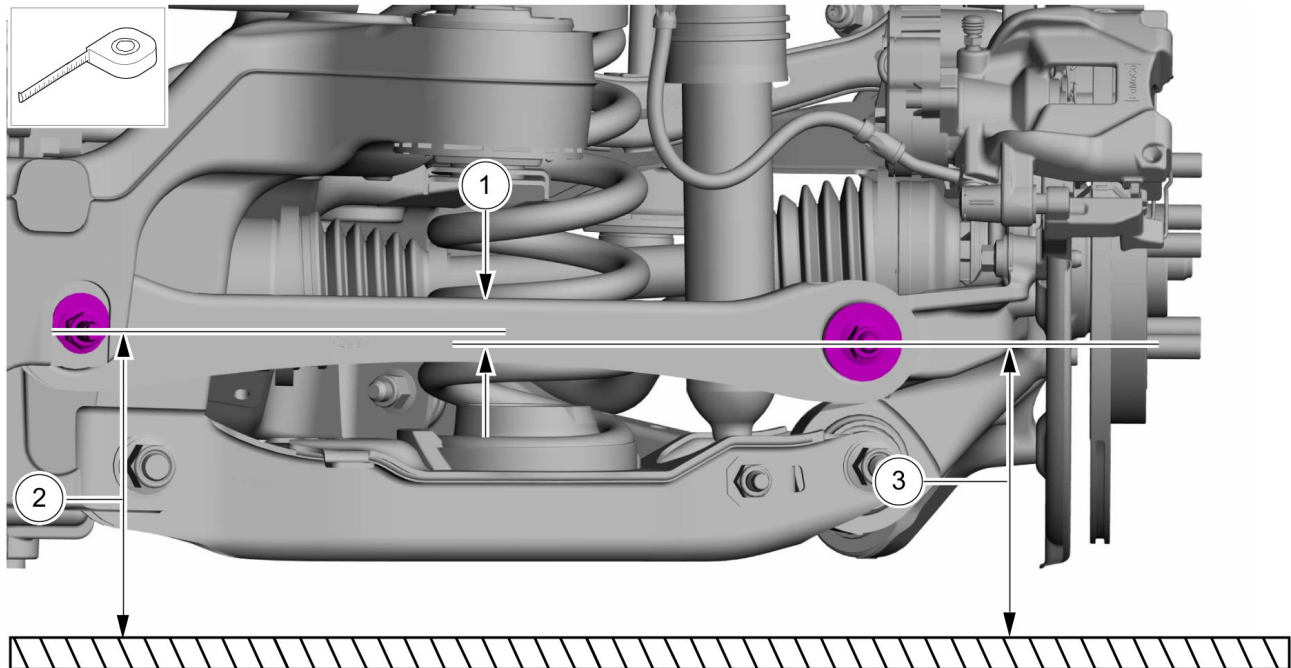

E344425

4. With the surface gauge positioned on a flat, level surface, record the measurement of the surface gauge position (measurement 2) and (measurement 3).

# Section 1: General Information

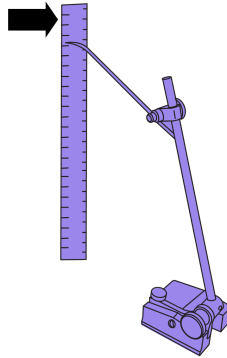

E145760

5. Subtract measurement 3 from measurement 2 to obtain the rear ride height.

### Ride Height Specifications

Item	Specification
<b>Ball Joint Deflection</b>	
Lower	0-0.8 mm (0-0.032 in)
<b>Ride Height</b>	
Front Ride Height	20.9 mm (0.822 in) ± 12 mm (0.472 in)
Rear Ride Height	-0.9 mm (-0.035 in) ± 12 mm (0.472 in)

## SECTION 2: Electrical

---

### Table of Contents

Contents	PAGE
Section 2: Electrical .....	2-2
High Voltage Battery Depowering .....	2-2
High Voltage Battery Depowering using FDRS .....	2-3
Manual De-Energizing .....	2-5
Electrical Basics .....	2-7
General Electrical Considerations .....	2-7
Electrical Systems Management .....	2-8
Vehicle Component Electrical Loads .....	2-8
General Guidelines .....	2-9
Splices and Repairs .....	2-15
Wiring Reference Information .....	2-20

## Section 2: Electrical

### Section 2: Electrical

#### High Voltage Battery Depowering

 **WARNING:**

THE HIGH-VOLTAGE SYSTEM MAY RETAIN A DANGEROUS LEVEL OF VOLTAGE FOR A SHORT TIME AFTER THE SERVICE DISCONNECT HAS BEEN OPENED. WAIT 5 MINUTES FOR THE VOLTAGE TO DISSIPATE BEFORE BEGINNING SERVICE. FAILURE TO FOLLOW THIS INSTRUCTION MAY RESULT IN SERIOUS PERSONAL INJURY OR DEATH.

 **WARNING:**

REMOVING THE BATTERY HIGH VOLTAGE SERVICE DISCONNECT DOES NOT DISSIPATE VOLTAGE INSIDE THE BATTERY PACK. THE BATTERY PACK REMAINS LIVE AND DANGEROUS. CONTACT WITH THE HIGH VOLTAGE BATTERY PACK INTERNALS MAY RESULT IN SERIOUS PERSONAL INJURY OR DEATH.

 **WARNING:**

ELECTRIC VEHICLES DAMAGED BY A CRASH MAY HAVE COMPROMISED HIGH VOLTAGE SAFETY SYSTEMS AND PRESENT A POTENTIAL HIGH VOLTAGE ELECTRICAL SHOCK HAZARD. EXERCISE CAUTION AND WEAR APPROPRIATE PERSONAL PROTECTIVE EQUIPMENT (PPE) INCLUDING HIGH VOLTAGE SAFETY GLOVES AND BOOTS. REMOVE ALL METALLIC JEWELRY, INCLUDING WATCHES AND RINGS. ISOLATE THE HIGH VOLTAGE SYSTEM AS DIRECTED BY THE FORD EMERGENCY RESPONSE GUIDE FOR THE VEHICLE. FAILURE TO FOLLOW THESE INSTRUCTIONS MAY RESULT IN SERIOUS PERSONAL INJURY OR DEATH.

 **WARNING:**

TO PREVENT THE RISK OF HIGH-VOLTAGE SHOCK, ALWAYS FOLLOW PRECISELY ALL WARNINGS AND SERVICE INSTRUCTIONS INCLUDING INSTRUCTIONS TO DEPOWER THE SYSTEM. THE TOTAL VOLTAGE OF THE VEHICLE HV BATTERY PACK MAY BE UP TO APPROXIMATELY 450 VOLTS DC. THIS VOLTAGE IS PROVIDED THROUGH HIGH-VOLTAGE CABLES TO ITS COMPONENTS AND MODULES. THE HIGH-VOLTAGE CABLES AND WIRING ARE IDENTIFIED BY ORANGE HARNESS TAPE OR ORANGE WIRE COVERING. ALL HIGH-VOLTAGE COMPONENTS ARE MARKED WITH HIGH-VOLTAGE WARNING LABELS WITH A HIGH-VOLTAGE SYMBOL. FAILURE TO FOLLOW THESE INSTRUCTIONS MAY RESULT IN SERIOUS PERSONAL INJURY OR DEATH.

 **WARNING:**

SERVICE OF THE HIGH VOLTAGE SYSTEM ON THIS VEHICLE IS RESTRICTED TO QUALIFIED PERSONNEL. THE REQUIRED QUALIFICATIONS VARY BY REGION. ALWAYS OBSERVE LOCAL LAWS AND LEGISLATIVE DIRECTIVES REGARDING ELECTRIC VEHICLE SERVICE. FAILURE TO FOLLOW THIS INSTRUCTION MAY RESULT IN SERIOUS PERSONAL INJURY OR DEATH.

 **WARNING:**

DISCONNECT THE 12V BATTERY BEFORE SERVICING THE DIRECT CURRENT TO ALTERNATING CURRENT (DC-AC) INVERTER OR ALTERNATING CURRENT (AC) POWERPOINT TO PREVENT THE RISK OF HIGH VOLTAGE SHOCK. FAILURE TO FOLLOW THIS INSTRUCTION MAY RESULT IN SERIOUS PERSONAL INJURY.

**NOTICE:**

Do not backprobe, splice or repair the high voltage (orange) wiring. Voltage in the system is approximately 450 volts DC. Damage may occur to equipment added to the system.

**NOTICE:**

None of the High Voltage Traction Battery (HVTB) wiring should be tapped or spliced to check for battery voltage (power), ground or signals.

**NOTICE:**

Modification of Low-Voltage (LV) power & control wires connecting to the High-Voltage (HV) battery system can damage or disable the HV Battery system. Do not open or modify High Voltage battery pack

Throughout a vehicle, electricity is supplied through "hot" wires, comparable to the pressurized supply pipes of a plumbing system. At various points along the wires are electrical loads in the form of lights, switches and receptacles. Turning on a light switch is somewhat like opening a

## Section 2: Electrical

faucet to let water run; electricity flows through the hot wire to make the light illuminate. Once the electricity has done its work, its potential drops to zero, just as water loses pressure after flowing through a sink or laundry tub. The electrical system has drains, which are the ground wires that return the electricity to its source, just as a plumbing system has drain pipes through which water runs into the sewer mains or ground.

The lights or equipment, technically called the load, can be compared to a water wheel that remains motionless until a stream of water causes it to turn. A load consists of a resistance, a material that permits the passage of electricity, but only with difficulty and thereby creates heat. Resistance to electricity flowing through a wire can be compared to the resistance given to water flowing through a hose, as if the hose were to be squeezed, it would restrict the flow of water. A load may also be inductive, typically a motor with windings of copper wire, in which the magnetic fields generated by the electrical current creates motion. The tungsten filament of an incandescent bulb or the heating element of an electric heater in a coffee pot would be an example of a resistive load. At any moment, the demand on an electrical system depends on the number of loads in operation and their consumption of energy, just as demands on a water system depend on how many faucets are opened and how wide they are opened.

The mechanics and physical fittings of the system are simple. Electricity moves throughout the vehicle in wires of different sizes, according to the electricity a circuit may have to carry.

### Electrical Terms

**VOLT** is the unit of electrical potential, equal to the difference of electrical potential between 2 points in a circuit. It could be compared to the pressure, or the push, on the water to move it through a pipe.

**AMPERE** or **AMPS** is the unit used to measure the amount of electrical flow; the number of electrically charged particles called electrons that flow past a given point in a circuit. It is similar to measuring the amount of water flowing through a pipe at any given point. The larger the pipe is, the more water that can flow past one given point per second. Similarly, the bigger the wire is, the more electricity that can flow past a given point.

**WATT** is the unit of power. It indicates the rate at which a device converts electric current to another form of energy, either heat or motion. Or to put it another way, the rate at which a device converts energy.

The relationship of volts, amperes and watts to one another is expressed in a simple equation that enables you to make any calculations you may need for proper and safe electrical modifications to the vehicle. Volts x Amps = watts. If the current is at 12 volts and a device requires 4 amperes of current, the equation will read 12 volts x 4 amperes = 48 watts.

To figure the current needed for a device rated in watts, turn the equation around: Watts/volts = amperes. For example, if you have a piece of equipment, such as a communications radio, that uses 120 watts: 120 watts/12 volts = 10 amperes.

### High Voltage Battery Depowering using FDRS

#### **WARNING:**

**Before beginning any service procedure in this manual, refer to health and safety warnings in Workshop Manual (WSM) Section 100-00 General Information. Failure to follow this instruction may result in serious personal injury.**

#### **WARNING:**

**To prevent the risk of high-voltage shock, always follow precisely all warnings and service instructions, including instructions to depower the system. The high-voltage system utilizes approximately 450 volts DC, provided through high-voltage cables to its components and modules. The high-voltage cables and wiring are identified by orange harness tape or orange wire covering. All high-voltage components are marked with high-voltage warning labels with a high-voltage symbol. Failure to follow these instructions may result in serious personal injury or death.**

1. Using the FDRS CARRY OUT the High Voltage System De-energizing routine and follow the on-screen instructions.
2. Detach the retainers and remove the LH underhood trim panel.

## Section 2: Electrical

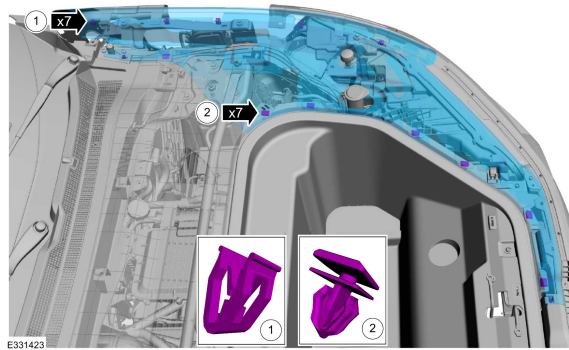

3. Release the Connector Position Assurance (CPA) clip.

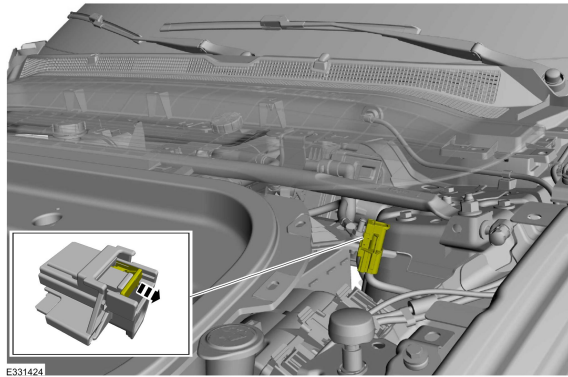

4. Depress the tab while pulling the connector until the hole is completely visible on the top of the connector.

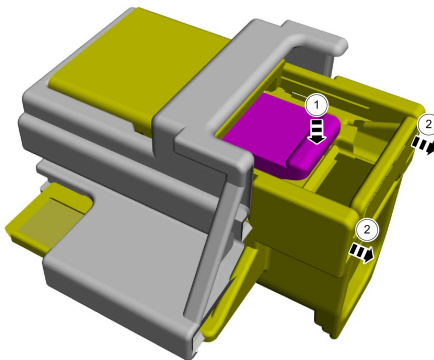

5. Insert a suitable tool inside the connector hole to prevent the connector from closing.

## Section 2: Electrical



- Using the FDRS COMPLETE the High Voltage System De-energization routine and verify the High Voltage System has been de-energized.

### Manual De-Energizing

#### **WARNING:**

To prevent the risk of high-voltage shock, always follow precisely all warnings and service instructions, including instructions to depower the system. The high-voltage system utilizes approximately 450 volts DC, provided through high-voltage cables to its components and modules. The high-voltage cables and wiring are identified by orange harness tape or orange wire covering. All high-voltage components are marked with high-voltage warning labels with a high-voltage symbol. Failure to follow these instructions may result in serious personal injury or death.

#### **WARNING:**

Before beginning any service procedure in this manual, refer to health and safety warnings in WSM Section 100–00 General Information. Failure to follow this instruction may result in serious personal injury.

#### **NOTICE:**

Manual De-energization should only be performed when a Ford-specific diagnostic tool is not available.

#### **NOTICE:**

Excessive use of this method may cause damage to electrical connectors.

#### **NOTICE:**

To prevent the risk of high voltage shock, the high voltage battery cover must not be removed if any of the following condition exist:

- BECM DTC P0AA6:00 that has been diagnosed to be an internal fault with the high voltage Battery.
- BECM Diagnostic Trouble Codes (DTCs) P0AA1:00 AND P0AA4:00 are present.
- BECM Diagnostic Trouble Codes (DTCs) P0D0F:00 AND P0AA4:00 are present.

1. Disconnect the Electric Vehicle Supply Equipment (EVSE) from the vehicle charge port. (PHEV only).
2. Turn the ignition ON without depressing the brake pedal (Accessory mode).
3. **NOTE:**  
A scan tool that is capable of performing a self-test on the BECM is required.

Using a scan tool perform BECM self test and record the Diagnostic Trouble Codes (DTCs).

- If BECM Diagnostic Trouble Codes (DTCs) P0AA1:00 AND P0AA4:00 are present. Refer to WSM procedures in section 414-03 High Voltage Battery, Mounting and Cables, Diagnosis and Testing.
- If BECM Diagnostic Trouble Codes (DTCs) P0AA1:00 AND P0D0F:00 are present (PHEV only). Refer to WSM Procedures in section 414–03A High Voltage Battery, Mounting and Cables, Diagnosis and Testing.

4. Detach the retainers and remove the LH underhood trim panel.

## Section 2: Electrical

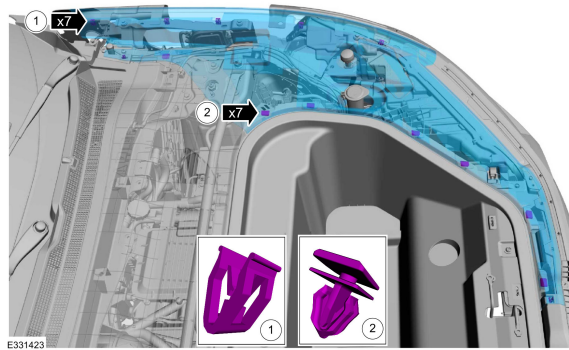

5. Release the Connector Position Assurance (CPA) clip.

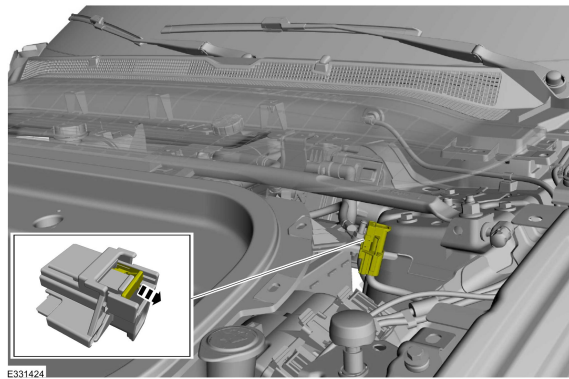

6. **NOTE:**  
The tab must be depressed prior to pushing the connector back in or damage to the connector may result.  
Depress the tab while pulling the connector until the hole is completely visible on the top of the connector.

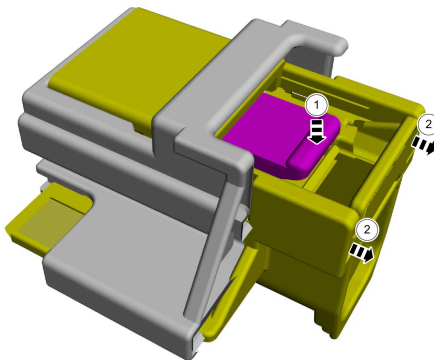

7. Insert a suitable tool inside the connector hole to prevent the connector from closing.

## Section 2: Electrical

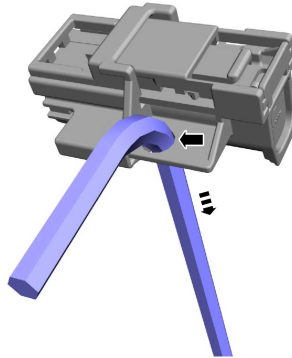

8. Disconnect the low voltage electrical connectors at the High Voltage Battery.
9. Disconnect the high voltage electrical connectors at the High Voltage Battery.
10. Wait a minimum of 5 minutes.

### Electrical Basics



#### **WARNING:**

**BEFORE CARRYING OUT ANY VEHICLE MODIFICATIONS, THE HIGH-VOLTAGE TRACTION BATTERY (HVTB) MUST BE DEPOWERED. FAILURE TO FOLLOW THESE INSTRUCTIONS MAY RESULT IN SEVERE PERSONAL INJURY OR DEATH.**

### Control Modules — Red Area

Do not install any components into the control modules or module harness. Connecting into this system may affect control module operation. For example, connecting of aftermarket electrical equipment into the brake light circuit or any other circuit which is connected to the PCM, anti-lock brake computer, air bag system or any other vehicle system will cause vehicle malfunction.

### Controller Area Network (CAN) Bus

#### **NOTICE:**

**Wiring faults in the controller area network (CAN) bus may shut down the vehicle and prevent further operation.**

Do not splice or connect any equipment to the controller area network (CAN) bus wiring.

### General Electrical Considerations

#### Communication Equipment

Mobile communication systems may harm the operation of the vehicle, particularly if they are not properly designed for automotive use or are not properly installed. Citizen band (CB) transceivers, garage door openers and other transmitters whose power output is 5 watts or less will not ordinarily affect the operation of the vehicle.

#### Vehicle Speed Signal

The vehicle speed signal is sent from the BCM to other vehicle modules through the CAN bus. There is a specific wire/circuit that carries the vehicle speed signal pulses.

#### Disabling Brake Lights

Do not disable the brake light circuits for any reason.

#### 12 Volt Battery

The 12 volt battery is a standard automotive battery. It is a DC source connected in a negative ground system. The battery case is sealed, with 2 vent holes to release gases. The battery has 3 major functions:

- Storage of electricity for later use
- Voltage stabilizer for the electrical system

## Section 2: Electrical

- Temporary power source when electrical loads exceed the DC/DC converter output current

### High and Low-Voltage Systems

**NOTICE:**

Do not backprobe or splice into the high-voltage system. The total voltage of the vehicle HV battery pack may be up to approximately 450 volts DC. Damage may occur to equipment added to the system.

### High-Voltage Traction Battery (HVTB)

**NOTICE:**

None of the high-voltage traction battery (HVTB) wiring should be tapped or spliced to check for battery voltage (power), ground or signals.

**NOTICE:**

Modification of low-voltage (LV) power & control wires connecting the high-voltage (HV) battery system can damage or disable the HV Battery system. Do not open or modify High Voltage battery pack

The high-voltage traction battery (HVTB) is a high voltage DC source connected in a floating ground system. The battery receives, stores and delivers high-voltage electrical power when required by the vehicle control strategy. On the HVTB there is 1 controller, a battery energy control module (BECM). There is also the High Voltage Battery Junction Box (HVBJB) which houses the contactors, current sensor and the associated components. The service disconnect is located under hood and is used to disconnect the high-voltage from the vehicle system. Always de-energize the High Voltage system prior to servicing a vehicles High Voltage componet.

### DC/DC Converter

The DC/DC converter is a liquid-cooled component that converts high-voltage DC power to low-voltage DC power. It is a module located in the engine compartment and maintains an electrical isolation between the 2 DC power systems. This system converts the high-voltage (approximately 450 volts) to low-voltage (12 volts) that provides power to the vehicle low-voltage battery systems. The PCM controls the operation of the DC/DC converter through an enabled input from the PCM to the DC/DC converter.

### Auxiliary Power Point — 12V

**NOTICE:**

Power outlets are designed for accessory plugs only. Do not insert any other object in the power outlet as this will damage the outlet and blow the fuse. Do not hang any type of accessory or accessory bracket from the plug. Improper use of the power outlet can cause damage not covered by your warranty.

**NOTE:**

Do not use the power point for operating the cigarette lighter element (if equipped).

To prevent the fuse from being blown, do not use the power point(s) over the vehicle capacity of 12-VDC/180W.

To prevent the battery from being discharged, do not use the power point longer than necessary when the engine is not running.

### Electrical Systems Management

Care must be given in deciding what equipment should be installed into a vehicle given the power demands of the equipment and the power available from the vehicle. Develop a power load strategy to minimize the risk of running out of power. Examine the proposed equipment for vehicle installation. Add up the current requirements. If the current requirements exceed what the vehicle can reasonably be expected to provide, the battery begins discharging to provide the power to the equipment that the generator is unable to provide. After some period of time, the vehicle shuts off as the battery voltage decreases to a level that cannot sustain vehicle operation.

There are alternatives that can be considered to minimize system electrical overload. Consider the current requirements of equipment before it is purchased and installed. For example, modern light bars and radios use a fraction of the current than units made as recently as 1996. The light bar is the most power intensive unit installed on most vehicles, considerable attention should be given to its current requirement. Changes in driver habits can make a difference in the electrical system load and will impact available power as well. When a vehicle is sitting and no one is in the car, certain electrical equipment can be turned off until the driver is ready to get back into the vehicle.

### Vehicle Component Electrical Loads

Vehicle component electrical loads are shown in the table below. Not all features are powered all the time, so actual vehicle loads on the power supply system will vary.

## Section 2: Electrical

**NOTE:**

The electric A/C compressor loads are included with the blower loads.

Component	Amps
<b>Base</b>	
Miscellaneous base loads	16.5
<b>Cooling</b>	
Cooling fan (high speed variable)	27.0
<b>Climate Control</b>	
A/C fan to face — high speed (recirculating air)	25.0
A/C fan to face — M/H speed (recirculating air)	16.0
Heater fan to foot — M/H speed (fresh air)	16.0
<b>Lighting</b>	
Exterior and instrument panel lamps (non-dimmable)	3.5
Headlamps — low beam	9.1
Brake lights (with CHMSL)	5.1
<b>Heated Features</b>	
Heated rear window (includes heated mirrors)	18.0
Heated front seat — LH	4.5
Heated front seat — RH	4.5
<b>Other</b>	
Radio	4.0
<b>Typical Vehicle Load = 95-110 Amps</b>	

### Typical Taxi Equipment

Loads for equipment commonly found on taxi vehicles are shown in the table below. Not all equipment will be operating at the same time, so actual loads on the power supply system will vary.

Component	Amps
Communications radio	5.0-20.0
Light bar	28.0-43.0
LED light bar	6.0
Taximeter	3.3
Receipt printer	3.0
Camcorder	2.0

### General Guidelines

- Do not open or modify the High Voltage Battery pack or any High Voltage Components.
- Do not modify the cooling system. High-voltage vehicle components may be damaged if any cooling system modifications are attempted.
- Do not backprobe, splice or repair the high-voltage system (orange) wiring/cables.
- Do not mount to or modify the high-voltage system (orange) wiring/cables in any way.
- Do not cut, weld or screw into the High Voltage Battery pack or any High Voltage Components case or penetrate the batteries in any way.

## Section 2: Electrical

- Air bag restraint systems must remain intact as received from Ford Motor Company. Before modifications are done to the vehicle, the system must be depowered by following the instructions provided in the current Workshop Manual.
- Provide circuit protection (fuses) for all wiring. The fuse rating should not exceed either the rated wiring current capacity or the total current requirements for all the add-on components on the circuit. Install fuses as close to the point of tapped power as possible.
- Provide protective covering in all areas that could be damaged during normal equipment installations.
- Do not allow control panels attached to the instrument panel to protrude into the driver and passenger air bag deployment zones. For additional information, refer to Section 4: Reference in this guide.
- Do not install switches and gauges in the driver or passenger knee impact areas.
- Provide adequate retention for wiring harnesses so they are clear of bolts, corners or edges which could abrade the wires during normal vehicle operation.
- Properly secure all wiring relocated or removed while working behind the instrument panel to prevent chafing, squeaks and rattles.
- Anticipate misrouted wiring situations and protect all wiring from penetration by screws and raw edges.
- Weather-seal all electrical connectors exposed to the elements.
- Do not use quick splice connectors or wire nuts.
- Install the fuse panel so fuses are readily accessible.
- Make sure that connections are easily accessible for assembly and service.
- Inspect all Ford gauges, lights and switches for correct operation after instrument panel work is performed.
- Make sure submersible connectors do not lose their seals under extreme assembly conditions such as bending wires 90 degrees immediately after the connector.
- Whenever using connectors, use a socket (female) connector on the electrical source side and a plug (male) connector on the electrical load side to reduce the possibility of a short circuit when disconnected.
- Adherence to the above guidelines is not to be construed as approval by Ford Motor Company of any specific revisions or additions to the vehicles original electrical system.
- Document all revisions to the electrical system and place with the vehicle Owner's Literature. Color code and/or label all revisions or additions to wiring.
- Disconnect the negative battery cable of vehicles stored on-site to reduce the possibility of draining the battery by lights or other equipment.

### Keep-Alive Memory (KAM) Power

The electronic motor and/or transmission control modules and the High Voltage Battery pack BECM require low battery voltage (12 volts) to be supplied at all times to maintain the keep-alive memory (KAM). Keep this in mind when installing load disconnect switches or solenoids.

### Equipment Grounding Guidelines

#### **NOTICE:**

**Do not use/modify any of the high-voltage system grounds or damage to the high-voltage components may occur.**

- Do not ground the body to the transmission or transmission crossmember. Ground accessories to the chassis or the vehicle battery.
- Splicing into circuitry relating to the electronic engine and/or transmission control systems is not acceptable because of the adverse effect on the electronic system operation.
- Adequately protect electrical connections exposed to the elements.

### Wire Insulation

- Polyvinyl chloride (PVC) rated at 90°C (194°F) is the standard wire insulation acceptable for inside body use but is not acceptable for underhood/underbody wiring.
- Hypalon insulation should be used on links only (Ford specification ESB-M1L54-A).
- Cross-linked polyethylene (XPLPE or SXL) rated at 125°C (257°F) is the required insulation for underhood/underbody applications (Ford specification ESB-M1L123-A).
- GXL can be used as an alternate wire (Ford specification ESB-M7L85B) as long as the concentricity specifications are met. To provide a water-resistant seal in conjunction with crimp connectors, a Duraseal® crimp connector is recommended since it is designed to account for outside wire diameter that is smaller than the present SXL wire.

### Terminals and Connectors

Connector Types:

- Submersible (sealed) — A connector that is capable of being immersed in water.
- Weather-resistant — A connector that will retain its sealing and connection qualities while being exposed to adverse weather conditions.

## Section 2: Electrical

- Duraseal® crimp — A supplier trade name for a sealed wiring repair or splice.

When a connection is not defined (typical situation — harness-to-harness connectors), the following suggestions should be implemented:

- Determine the connector type. If it will be located in a hostile environment, use a sealed connector; if not, use an open connector. A hostile environment is defined as being exposed to water and/or salt accumulation and/or high temperatures (that is; underhood, exterior panels and footwells). Use in-line connectors with secondary locks to prevent the terminal from being pushed out.
- Do not use single wires smaller than 14 gauge in a 2-way or larger weather-resistant connector (the very large style), since the wire may break during disengagement.
- Use Hypalon, XLPE or Elexar insulation in submersible connectors to maintain sealing integrity. PVC is not acceptable because its properties allow it to set in a deformed pattern, therefore compromising the integrity of the seal.
- Determine the terminal type. Base your decision on wire gauge, current carrying capacity, connector type and insulation type.
- Use non-detent low insertion force terminals whenever possible.
- Do not use low insertion force female terminals in weather-resistant connectors.
- Analyze circuit requirements (signal levels, current, voltage) to determine the proper plating material (such as gold). Use of non-plated terminals is not recommended.
- Do not use plugs to seal holes in micropin connector grommets. It is very easy to forget to insert them during manufacturing and ruin the seal. Use a grommet with only the necessary number of holes or use dummy wires at least 600 mm (24 in) long.
- Fully align connectors prior to terminal connection — terminal cavities should have minimum tolerance to prevent terminals from floating, bending or pin push-out during mating/engagement.
- Make sure connectors of similar type and color are identifiable to the operator to eliminate crossed connections and minimize assembly time. Avoid using similar types and colors of connectors close together.
- Be sure that connectors have positive locking devices that allow easy installation with a low insertion force and easy removal. The connector snap should be easily felt and heard.
- Eliminate the use of edgeboard, tang-type and molded-over connectors. The use of blade-type weather-resistant connectors is restricted to high-current applications which cannot be handled by submersible connectors.

### Circuit Protection and Electrical Load

- Modification to the vehicles existing low-voltage (12 volts) wiring should be done only with caution and careful consideration of effects on the completed vehicles electrical system. Anticipated circuitry should be studied to determine the required circuit protection and to avoid feedback loops.
- Added circuitry must be protected either by a base vehicle fuse or circuit breaker, or by a similar device supplied by the modifier.
- When adding loads to a base vehicle-protected circuit, make sure the total electrical load through the base vehicle fuse or circuit breaker is less than the devices load rating.
- Use 80% of the fuse rating to determine maximum steady state load to reduce nuisance fuse failures.
- Use 135% of the fuse rating when sizing wiring to protect the circuit in the event of an overload. Fuses will last for one hour at 135% of their rating.
- Total current draw is the sum of the base vehicles circuit current requirement (measured with an ammeter) and the anticipated add-on component current requirements.
- Never increase the rating of a factory installed fuse or circuit breaker.
- If the total electrical load including additional electrical components, on any circuit, is less than the fuse protection rating or the capacity of some limiting component (switch, relay), the items to be added can be connected directly to that circuit. The headlamp switch circuits should never have additional lighting or electrical components directly connected.
- Added devices that exceed the current capabilities of the factory-installed system are best controlled through the use of a relay or separate switch. The coil of the relay can be fed from the circuit in the factory harness (now acting as a signal circuit) with added wiring providing feeds to the added electrical device. The relay selection is important and depends on current requirements, number of cycles expected in the relay lifetime, whether the relay is to be operated intermittently or for long periods of time and whether the relay is exposed to weather conditions or is installed in a protected area. When the current requirements of a circuit exceed the capacity of an available relay, the load should be reduced or divided through the use of additional relays.

### Wire Protection Requirements

#### General Notes

- Anticipate problems and design accordingly. Try to anticipate what could go wrong and modify your designs to address any adverse impact.
- Review all connector applications and electrical systems to determine the need for solder, grease, weather-resistant or sealed connectors. Make sure components and wire insulation are compatible with greased connectors (important for long-term durability).
- Make sure that drip loops or other means are provided to prevent water leakage into the vehicle through wiring assemblies that pass through the dash panel.

## Section 2: Electrical

- Use greased or sealed connectors in floor pan troughs which are subject to moisture coming through the carpeting.
- Use XLPE insulation for uncovered runs that exceed 305 mm (12 in).

### Electrical Protection

- Properly route wires away from noise-generating wires or components. However, if routing near noisy wires or plugging into noisy components is unavoidable, design additional protection into the harness.
- Electromagnetic interference (EMI) shielding — Consider shielding if you must route close to high-current or noisy circuits. Use shielded wire and ground one side. Seal all splices in wire assemblies that use bare coaxial shielding (braid or tape) for EMI suppression, and insulate or tape over all shielding ends that terminate near any open connectors. This prevents splice and terminal shorts to the shielding. Minimize the length of conductors which extend beyond the shield. Failure to do this reduces the effectiveness of the shield.
- Spike suppression, in general, is accomplished by connecting a diode or resistor-diode combination across the terminals of the noisy component. The diode should be sufficiently close to the component (both electrically and physically) so that inductive spikes are clamped off. Make sure the diode is connected with the proper polarity.

Proper routing and retention reduces the likelihood of chafing or pinching. When this ideal routing is unattainable, the following additional protection is needed:

### Mechanical/Environmental Protection

#### NOTE:

This is not meant to be an all-inclusive list of methods for physically protecting the wires. There are other means of protection available that are not listed.

- Tape — Tape is the most basic means of protection. It contains the wires in a loose bundle and provides limited environmental protection. It does not protect against chafing and pinching.
- Kendall polyken fiberglass base tape (Ford specification ESB-M3G38-A) is used for engine compartment applications. This durable tape provides protection against cut-through and abrasion commonly found in underhood applications.
- Polyken 267 is a substitute tape that may be used in lower temperature areas of the engine compartment (apron area).
- Convolute — Use convolute for all underhood/underbody applications or when increased temperature, abrasion or pinch resistance is required. Convolute tubing comes in different diameters and materials to accommodate different temperature ranges and harness sizes.
- Use polyethylene convolute when abrasion is the only consideration; this convolute is adequate up to 96°C (205°F) maximum. Use nylon convolute when underhood/underbody or abrasion and temperature are considerations; nylon convolute is adequate up to 177°C (350°F) maximum.
- On all engine-mounted wiring or bend points, use vinyl tape on the outside of the convolute to prevent wiring from looping out. This tape must be able to withstand temperatures 135°C (275°F) or higher.
- Tape convolute junctions with abrasion-resistant tape (Polyken 267, fiberglass).
- Scroll — Similar to convolute, but without the ridges. Scroll is used where harness rigidity is required, especially for maintaining critical locator dimensions. Use scroll for short lengths only, as it is inflexible.

### Grommets and Sealing Requirements

Any additional wiring routed through sheet metal must pass through a grommet that both seals the opening and locates the wire(s). Two-piece grommets (rubber with plastic inserts) are recommended to facilitate installation and retention.

- Locate grommets so they are accessible for proper seating (achieved by pulling) in sheet metal holes.
- Ramp grommets at the insertion end to facilitate installation and sealing.
- Be sure the direction of the hole punch is in the direction of grommet seating and the hole is burr-free.
- Make sure the grommet molding compound adheres to the harness to prevent slippage.
- Make sure the grommet will withstand the environment (temperature, splash).
- Be sure the holes are large enough to allow the installation of the harness without causing circuit damage.
- Use adhesive tape on main trunks or branches with at least a 50% overlap to prevent wicking through grommets. Be certain to diaper-wrap the takeouts.

### Wire Routing



#### **WARNING:**

**Do not place electrical component attachments or ground screws adjacent to vehicle fuel tanks, fuel filler pipes, fuel lines, fuel vapor lines or carbon canisters. Failure to follow these instructions may result in severe personal injury in the event of a collision.**

## Section 2: Electrical

Wire harness routing should conform to the following:

- Protect wires routed through holes in sheet metal or castings with a grommet whether or not conduit is used (see figure below).

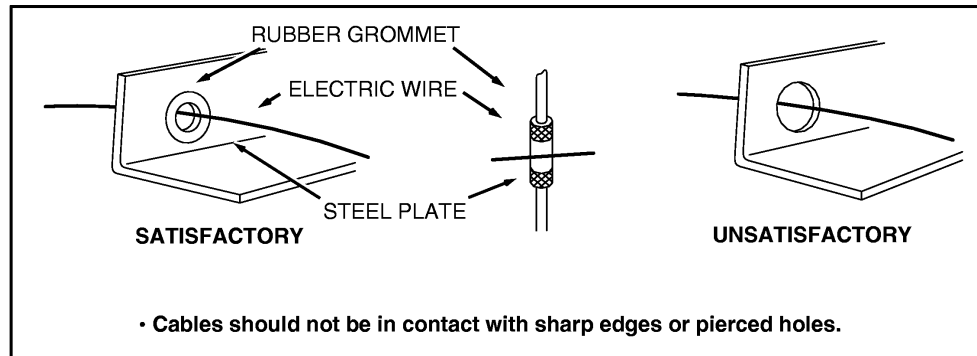

A0073515

- Route wires to avoid metal edges, screws, trim fasteners and abrasive surfaces. When such routing is not possible, use protective devices (shields, caps) to protect the wires. Cover metal edges with a protective shield and fasten the wiring within 76 mm (3 in) on each side of the edge (see figure below).

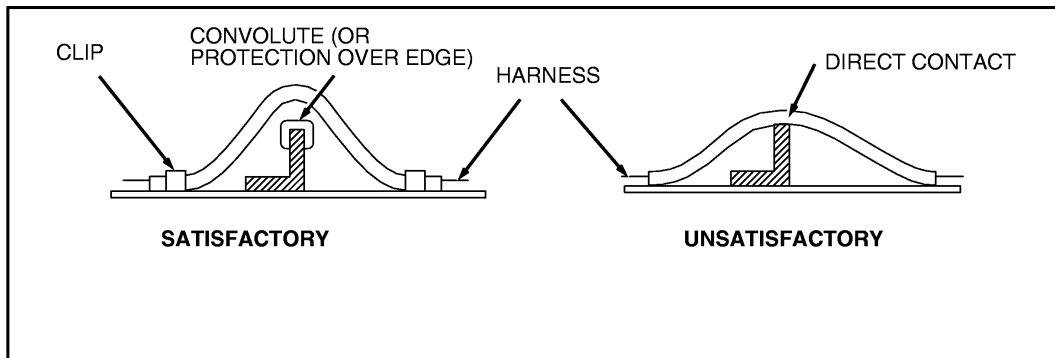

A0073514

- Route wires to provide at least 76 mm (3 in) of clearance to moving parts in their extreme movement location, unless positively fastened and protected by conduit.
- Avoid wire routing without conduit in areas where temperatures exceed 82°C (180°F). Heat insulation and heat shields must be used on the wires routed in high-temperature areas.
- Make certain that all underhood or underbody wiring is cross-linked polyethylene high-temperature insulation wire 135°C (275°F) (minimum rating) consistent with SAE specification J1128 Type SXL wire. Normal PVC wire must not be used in underhood or underbody applications.
- Make sure all ground locations are readily accessible for installation, service and verification.
- Do not place ground attachments in high-splash areas.
- Underhood/underbody wiring must be routed in conduit for protection. Minimum conduit rating is 177°C (350°F).

### Wire Retention and Routing

Use the following criteria to determine the location of retainers:

- Size and weight of wire bundle.
- Holes with poor accessibility that prevent installation of locators.
- Movement of wires that can result in abrasion, squeaks and rattles.
- When wiring is routed between 2 members where relative motion can occur, the wiring should be secured to each member with enough wire slack to allow flexing without damaging the wire.
- Wiring exposed to weather must provide a drip loop to prevent moisture from being conducted into the device through the wire connection (see figure below).

## Section 2: Electrical

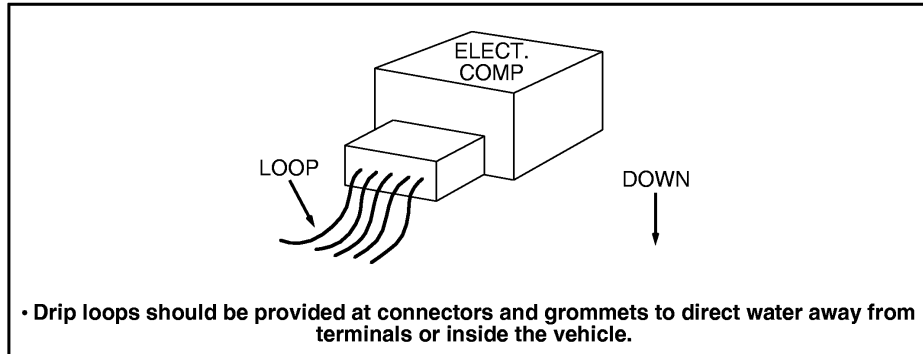

A0073517

- Avoid routing wires into areas exposed to wheel splash. When such routing cannot be avoided, adequate clipping and/or protective shields are required to protect the wires from stone and ice damage. Allow adequate slack in wiring between the engine and stationary components to compensate for engine roll.
- Avoid routing wires under the frame side members or at points lower than the bottom frame flange.
- Use plastic zip straps for bundling only (securing to other wires).
- The wire retainers and grommets installed by the assembly plant are usually designed to accommodate only the Ford-installed wires. Additional wiring or tubing should be retained by additional clips. When added wires or tubes are routed through sheet metal panels, use new holes with proper wire protection and sealing.

## Section 2: Electrical

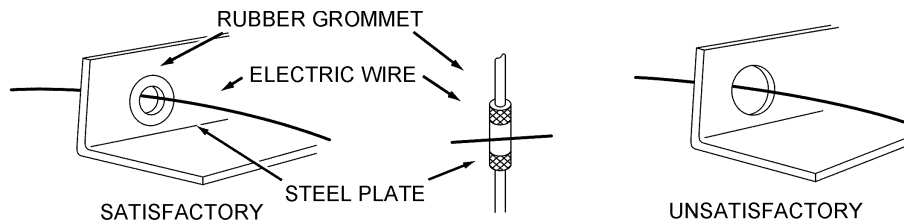

- Cables should not be in contact with sharp edges or pierced holes.

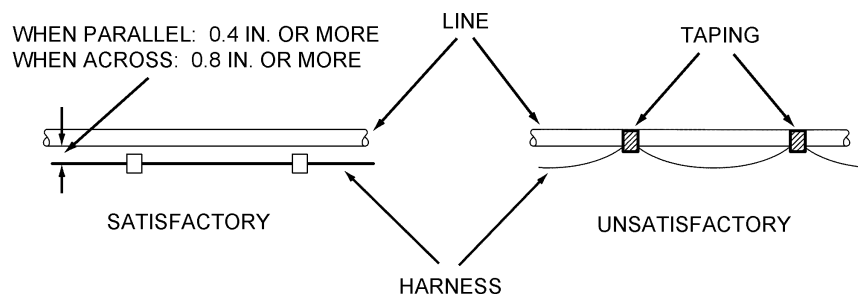

- Harnesses should not be taped to fuel lines or other lines. A sufficient clearance should be maintained between harness and lines.

N0070449

For retainer screws, the following guidelines apply:

- Avoid using fasteners that are too long for the application or are in an area which might damage vehicle components, including wiring, brake lines, fuel tank and lines, powertrain components, exhaust system and suspension.
- Do not use pointed screws for attachments. Make sure that screws used in the vicinity of the wiring are blunt-ended.
- To minimize the potential for wiring shorts, do not use drill point screws. Trim components (including wiring shields) should use pin-type attachments instead of screws.
- Always check areas that screws protrude into for verification that an interference condition to other components does not exist.
- Make sure that retainers used are capable of withstanding the environment over the vehicle's life expectancy.

### Splices and Repairs



#### WARNING:

Do NOT splice into or repair high-voltage (orange) wiring/cables. The high-voltage in this system is approximately 450 volts DC. Failure to follow these instructions may result in severe personal injury or death. In addition, if any high-voltage connectors, modules, or cables are damaged they must be replaced.

- Stagger the splices within a harness to reduce increased harness diameter. Splice only on straight areas as installed, not on bends.
- Strip wire ends, making sure that individual conductor strands are not damaged.

## Section 2: Electrical

- When soldering, make sure an adequate mechanical joint exists before applying solder. Use only resin-core solder. Acid-core solder should not be used since it may result in corrosion.
- For crimp joints, use butt-type metal barrel fasteners and the proper tool at the appropriate setting for the wire size (such as Motorcraft® Crimp Tool S-9796) specifically designed for this type of work.
- Make sure splice joints are adequately sealed and insulated. In an outside environment, use Duraseal® butt connectors or equivalent. A durable substitute splice joint can be achieved by using a bare metal barrel, crimping, flow-soldering and covering with shrink tubing. Quality electrical tape can be used inside the vehicle but is not recommended for an outside environment.
- Make sure the new wire is not a lesser gauge than its original mating wire.

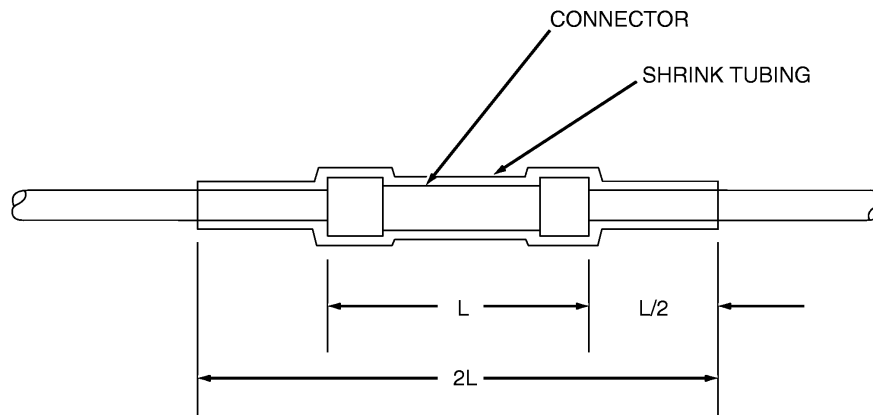

A0074039

### Recommended Splicing Method — Solder (For 16 AWG and Smaller Diameter Wire Only)

1. Disconnect the battery ground cable.
2. Strip wires to appropriate length.

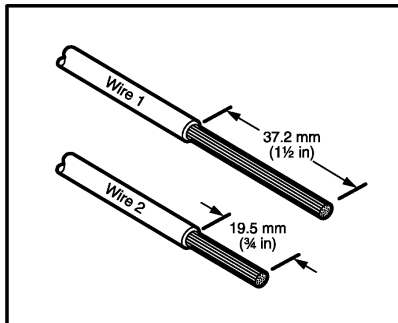

A0075761

3. Install heat shrink tubing.
4. Twist the wires together.
5. **NOTE:**  
Use resin-core mildly-activated (RMA) solder. Do not use acid-core solder.  
  
Solder wires together.

## Section 2: Electrical

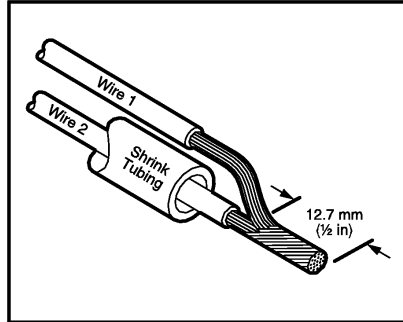

**A0075762**

6. **NOTE:**  
 Wait for solder to cool before moving wires.  
 Bend wire No. 1 back in a straight line.

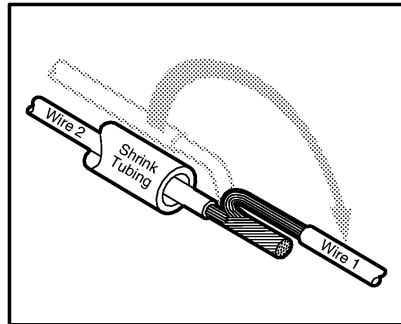

**A0075763**

7. **NOTE:**  
 Overlap tubing on both wires.  
 Evenly position heat shrink tubing over wire repair.

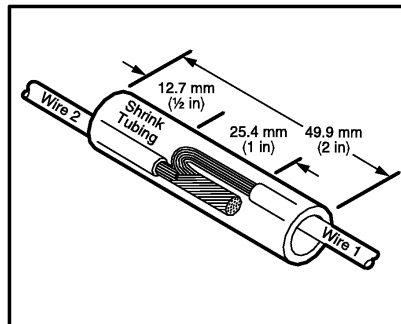

**A0075764**

8. Use a shielded heat gun to heat the repaired area until adhesive flows out of both ends of heat shrink tubing.

# Section 2: Electrical

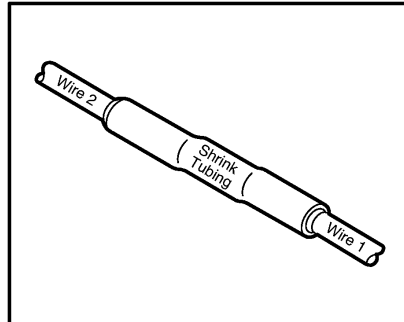

A0075765

- Reconnect the battery ground cable.

**Sealed Connectors**

Ford Part Number	Part Name	Class
E6FZ-14488-A	Butt Connector Gauge: 18-22, Color: Red	C
E6FZ-14488-B	Butt Connector Gauge: 14-16, Color: Blue	C
E6FZ-14488-C	Butt Connector Gauge: 10-12, Color: Yellow	C

**Heat Shrinkable Tubing (Heat Shrink) (Ford Specification ESB-M99D56-A2)**

Heat shrinkable tubing is available in various diameters for different splice sizes and configurations. When shrunk, it forms a small, flexible hermetic seal.

Other methods (tape, PVC mold) do not provide a hermetic seal and are not recommended. Splice balancing is critical with heat shrink insulation. If the splice is extremely unbalanced (more circuits on one side than the other), heat shrink insulation will not provide a proper seal. Evaluate the use of double terminals instead of splices where practical in these situations.

**Recommended Splicing Method — Crimp (For 10 - 22 AWG Diameter Wire to Like Wire Diameter)**

- Disconnect the battery ground cable.
- Strip wires to appropriate length.
- Install heat shrink tubing.

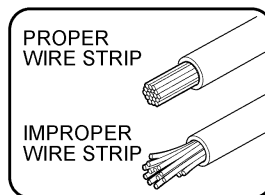
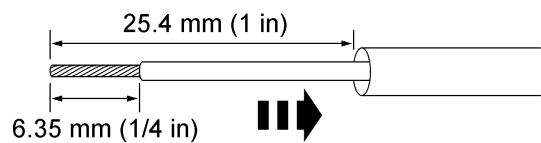

N0104085

- Select the appropriate wire splice for the wires to be spliced from Rotunda Wire Splice Kit 164-R5903.
- NOTE:**

## Section 2: Electrical

Rotunda Pro-Crimper 164-R5901 supplied with the wire splice kit is the only tool that can be used with these splices.

Identify the appropriate chamber on the Rotunda Pro-Crimper by matching the wire size on the dies with the wire size stamped on the butt splice.

- (1) Cavity
- (2) Indenter

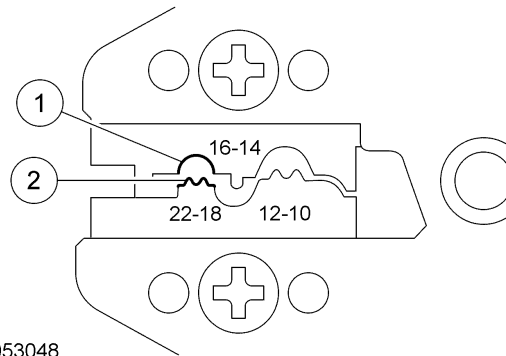

6. Crimp the connector.
  - (1) Center one end of the wire splice in the appropriate crimping chamber.
  - (2) Insert stripped wire into the barrel.
  - (3) Holding the wire in place, squeeze the tool handles until the ratchet releases.

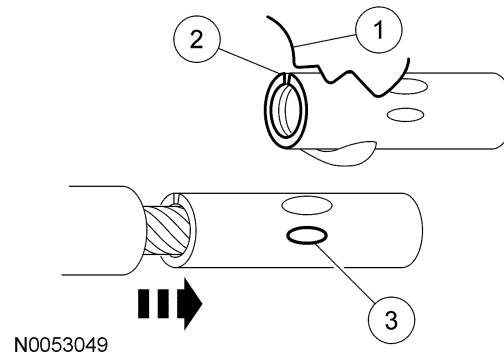

7. Repeating Step 6, crimp the other half of the splice.
8. Check for acceptable crimp.
  - (1) Crimp should be centered on each end of the butt splice.
  - (2) Wire insulation does not enter butt splice.
  - (3) Wire is visible through inspection hole of splices.

## Section 2: Electrical

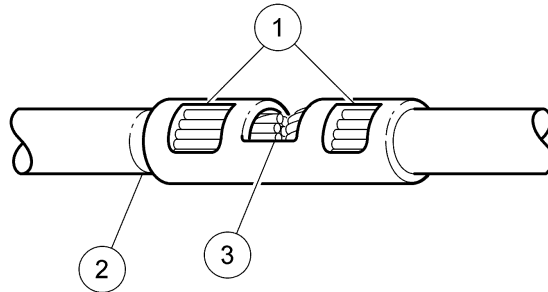

N0053050

9. Evenly position supplied heat shrink tubing over wire repair.
10. Use a shielded heat gun to heat the repaired area until adhesive flows out of both ends for the heat shrink tubing.

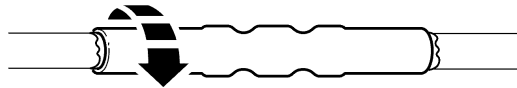

N0070450

11. Reconnect the battery ground cable.

### Wiring Reference Information

#### Wiring Diagram Excerpts

The following pages are from sections of the Wiring Diagrams manual.

#### Ordering Information

To obtain information about ordering complete copies of Ford publications, call 1-800-782-4356.

In addition, a publications order form can be obtained by writing to: Ford Publications, C/O Helm Inc., PO Box 07150, Detroit, MI 48207.

Available publications include Workshop Manuals, Wiring Diagrams manual, PC/ED Manuals and Owner's Literature.

### Wiring Diagrams



#### **WARNING:**

The following wiring diagrams contain high-voltage circuits. Do not backprobe, splice, modify or repair in any way. The system voltage is approximately up to 450 volts DC. Failure to follow this instruction may result in severe injury or death.

### Charging System

# Section 2: Electrical

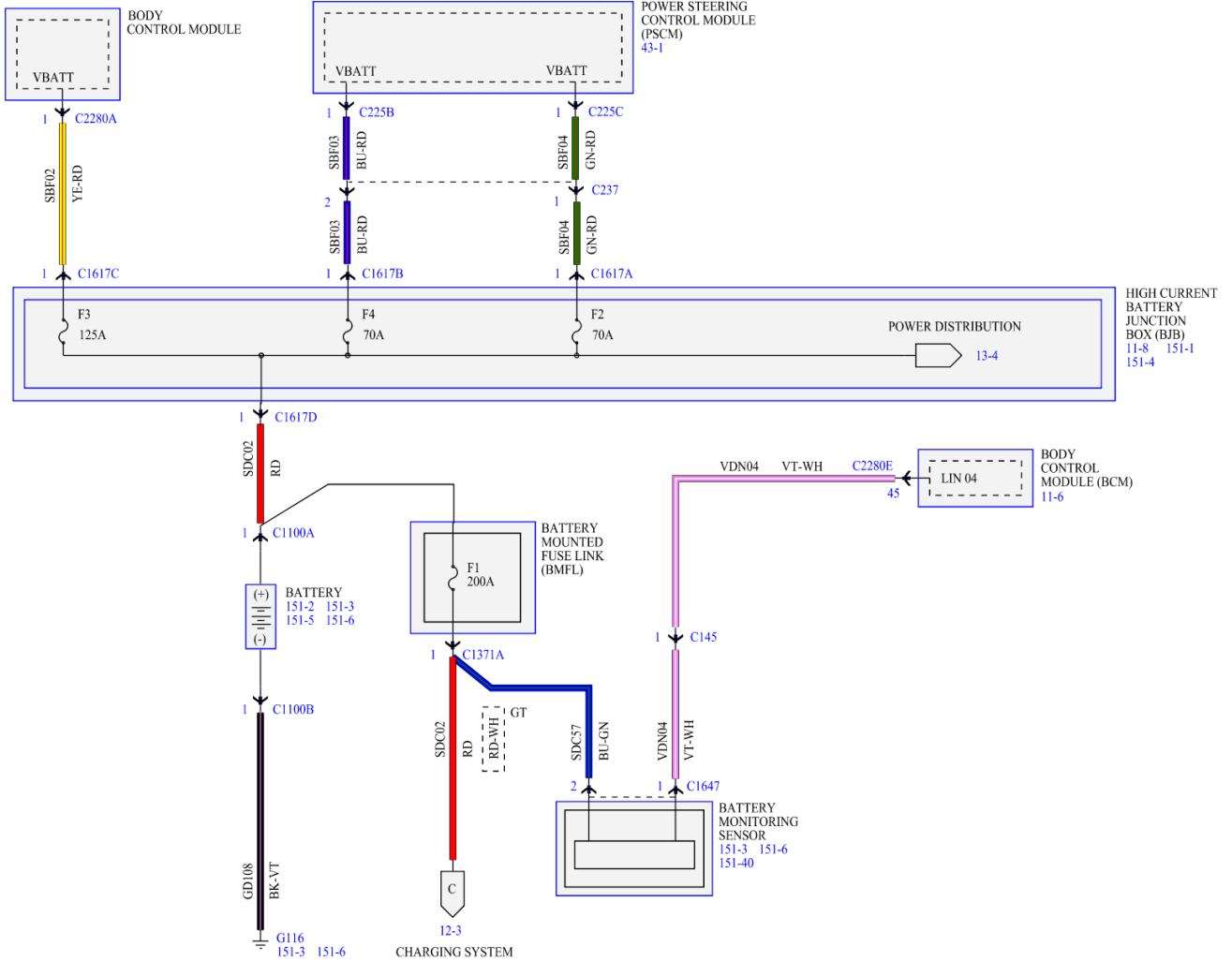

N0183443

# Section 2: Electrical

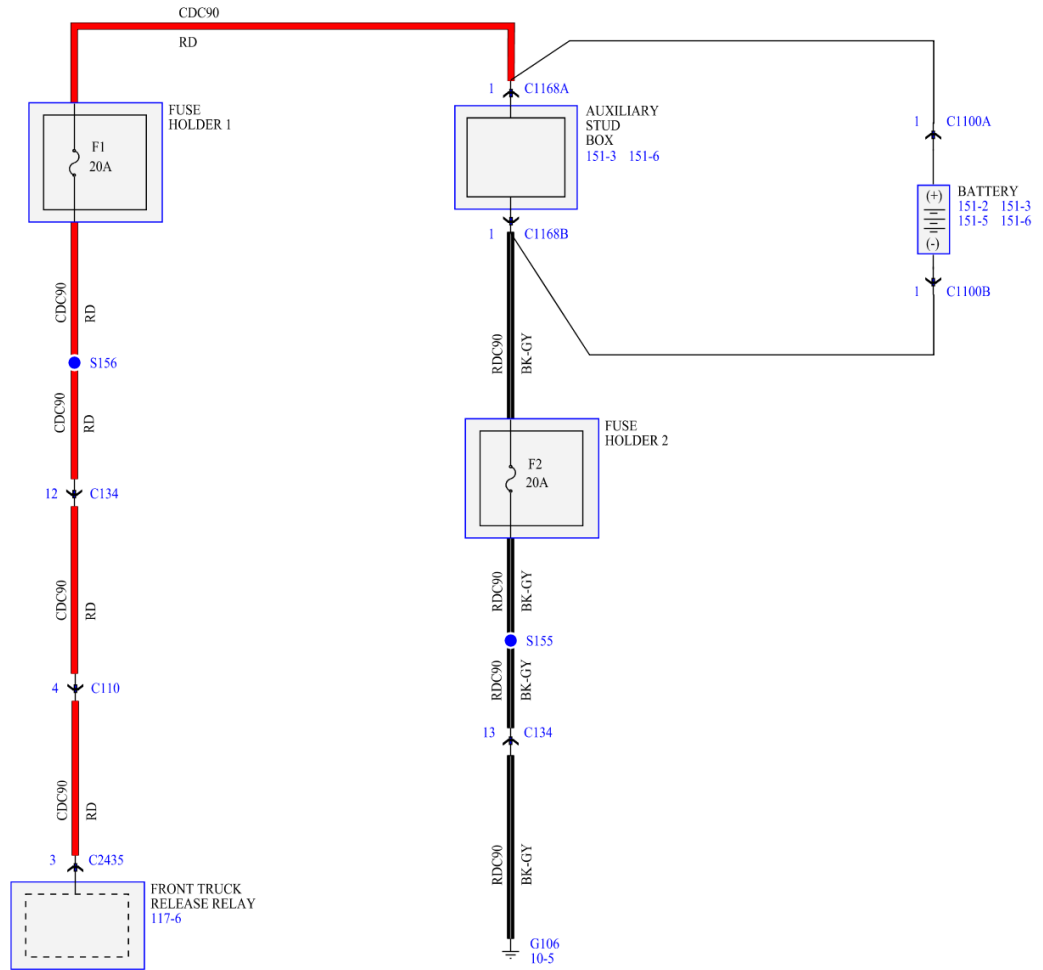

N0183444

## Section 2: Electrical

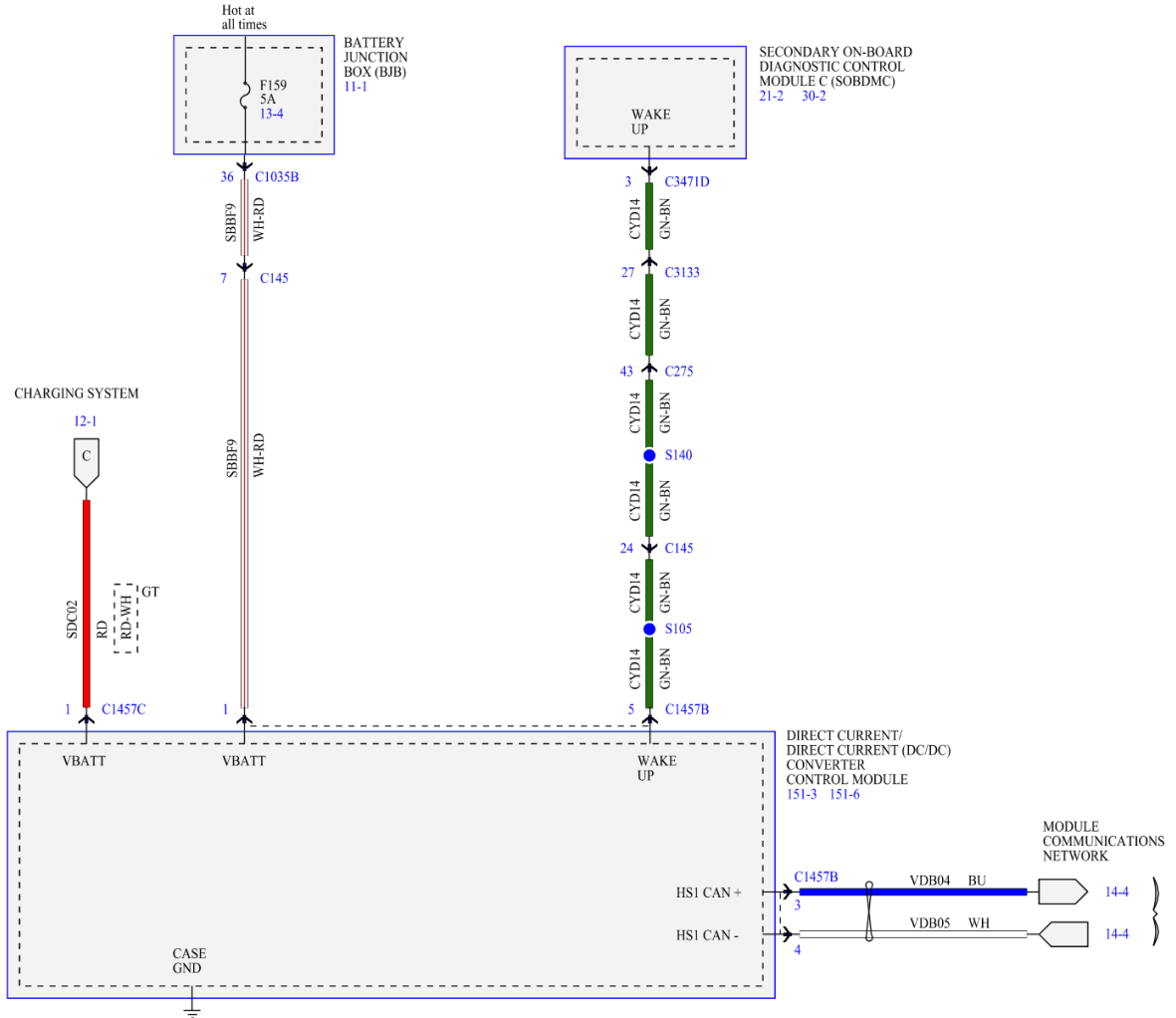

N0183445

## Section 2: Electrical

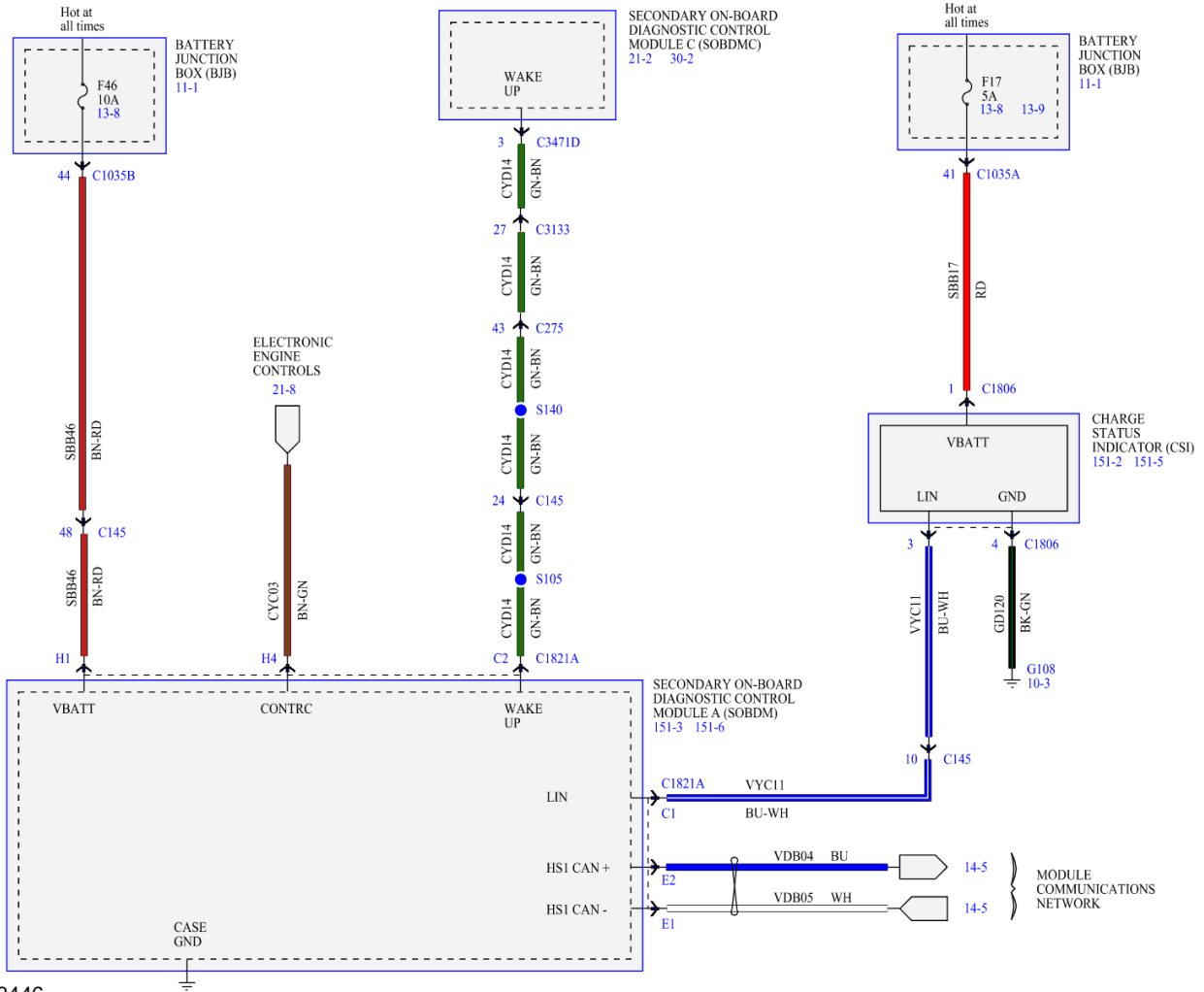

N0183446

## Section 2: Electrical

NORTH AMERICA

**WARNING:**

- ⚠ To prevent the risk of high-voltage shock, always follow precisely all warnings and service instructions, including instructions to depower the system.
- The high-voltage system utilizes approximately 300 volts DC, provided through high-voltage cables to its components and modules.
- The high-voltage cables and wiring are identified on the vehicle by orange harness tape or orange wire covering.
- All high voltage components are marked with high voltage warning labels with a high voltage symbol.
- Failure to follow the instructions may result in serious personal injury or death.

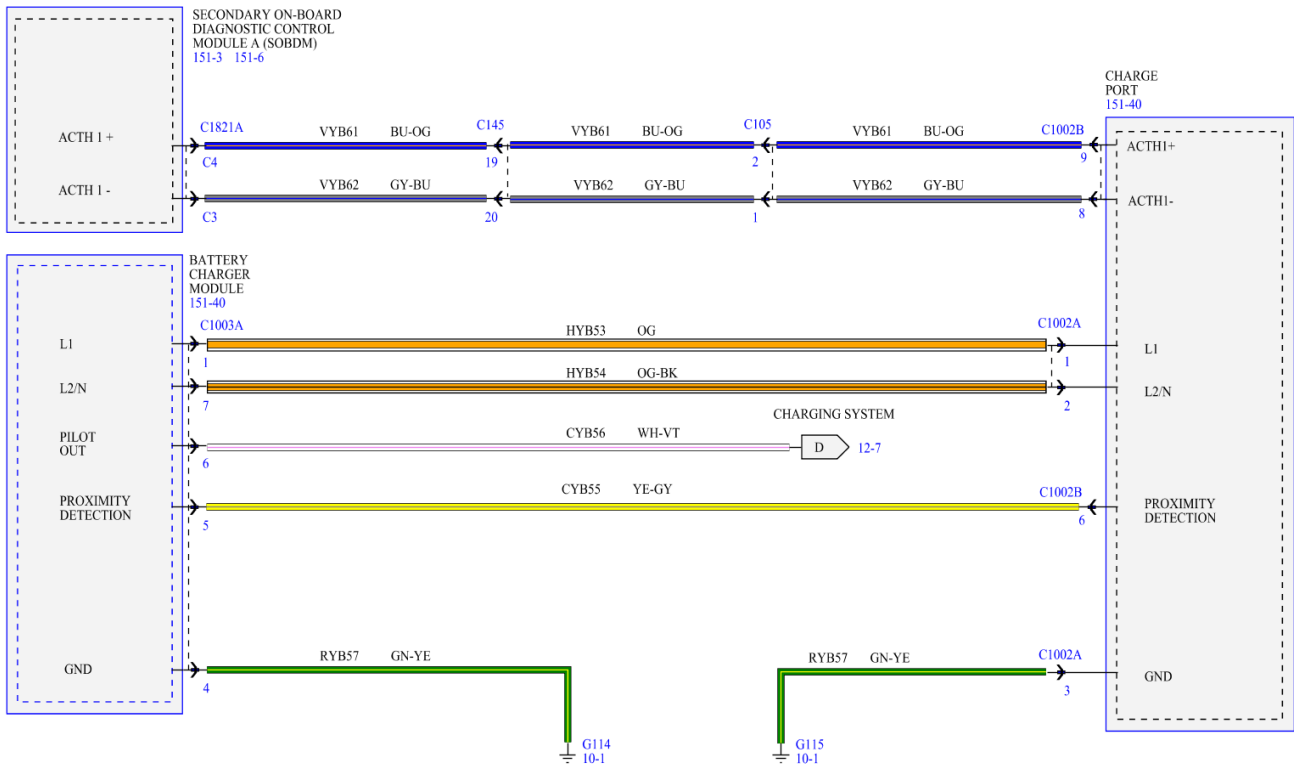

N0183447

## Section 2: Electrical

EUROPE



**WARNING:**  
 To prevent the risk of high-voltage shock, always follow precisely all warnings and service instructions, including instructions to depower the system.  
 The high-voltage system utilizes approximately 300 volts DC, provided through high-voltage cables to its components and modules.  
 The high-voltage cables and wiring are identified on the vehicle by orange harness tape or orange wire covering.  
 All high voltage components are marked with high voltage warning labels with a high voltage symbol.  
 Failure to follow the instructions may result in serious personal injury or death.

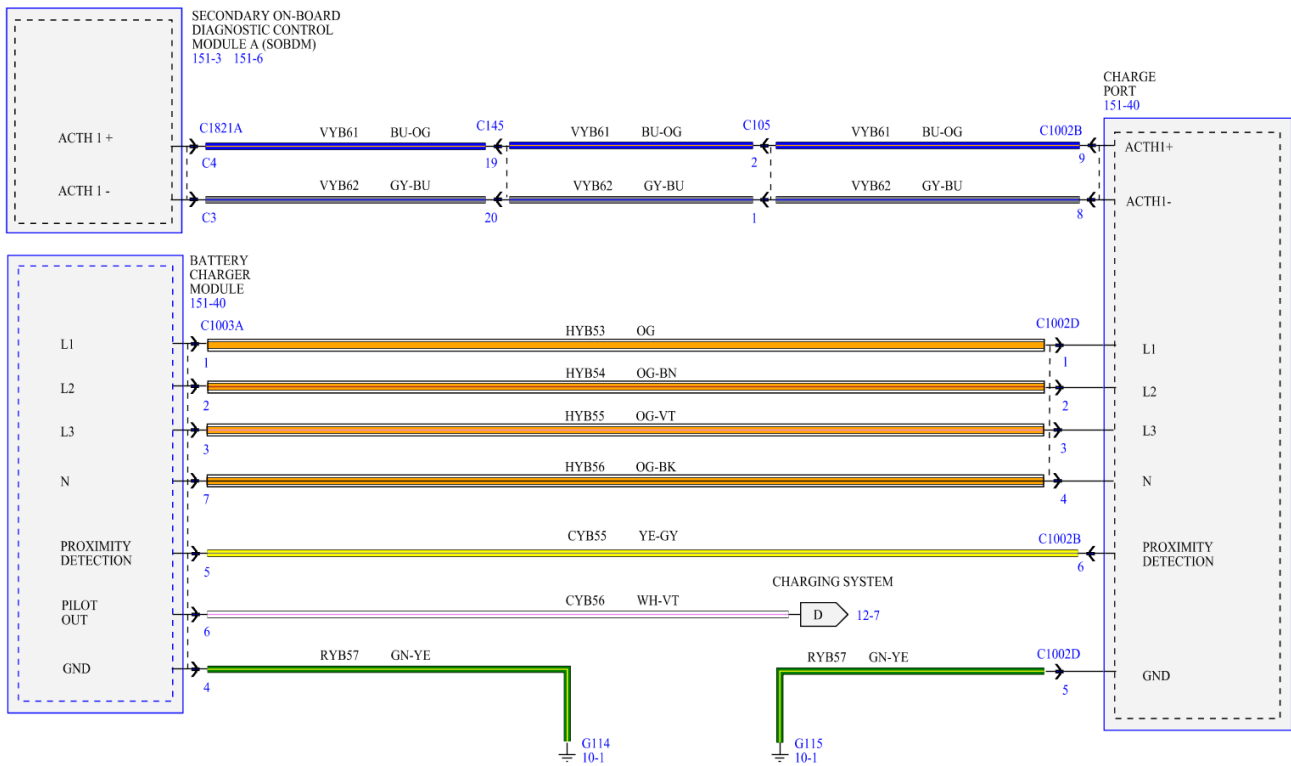

N0183448

## Section 2: Electrical



**WARNING:**  
 To prevent the risk of high-voltage shock, always follow precisely all warnings and service instructions, including instructions to depower the system.  
 The high-voltage system utilizes approximately 300 volts DC, provided through high-voltage cables to its components and modules.  
 The high-voltage cables and wiring are identified on the vehicle by orange harness tape or orange wire covering.  
 All high voltage components are marked with high voltage warning labels with a high voltage symbol.  
 Failure to follow the instructions may result in serious personal injury or death.

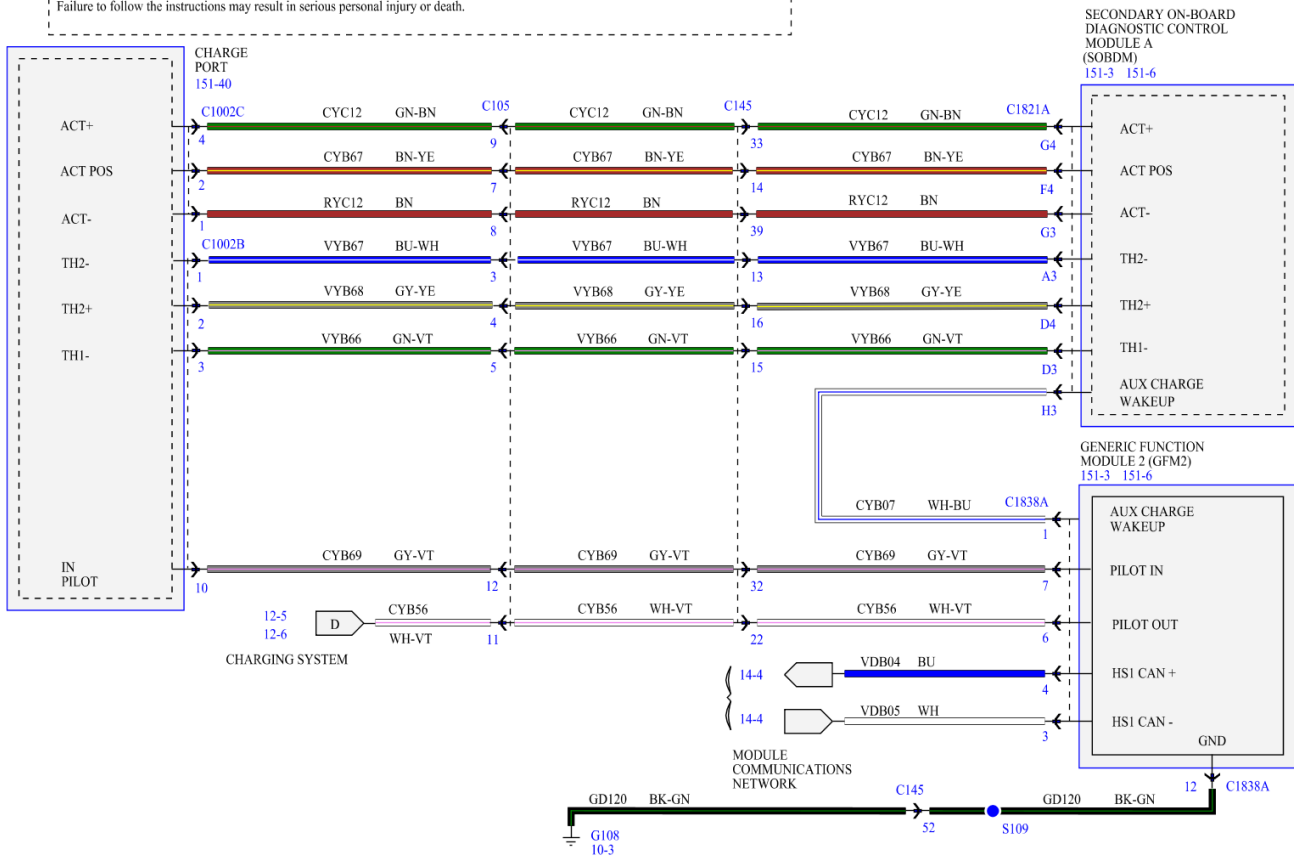

N0183449

## Section 2: Electrical

**WARNING:**  
 To prevent the risk of high-voltage shock, always follow precisely all warnings and service instructions, including instructions to depower the system.  
 The high-voltage system utilizes approximately 300 volts DC, provided through high-voltage cables to its components and modules.  
 The high-voltage cables and wiring are identified on the vehicle by orange harness tape or orange wire covering.  
 All high voltage components are marked with high voltage warning labels with a high voltage symbol.  
 Failure to follow the instructions may result in serious personal injury or death.

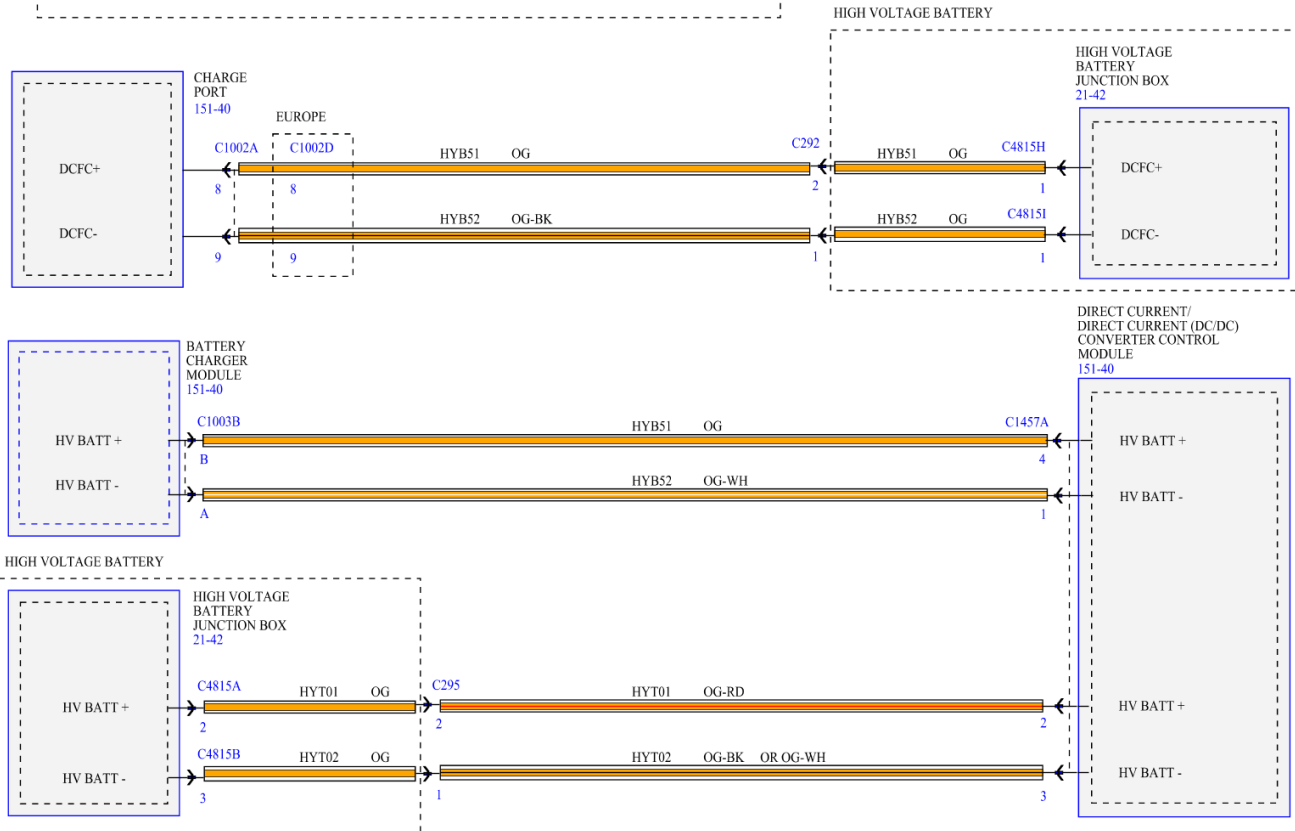

N0183450

## SECTION 3: Mounting

---

### Table of Contents

Contents	PAGE
Section 3: Mounting .....	3-2
Push Bumpers .....	3-2
Cooling System Note .....	3-2
Mounting Equipment to the Vehicle .....	3-2
Airbag, Safety Restraint System and Side Impact Sensor Component Description and Location .....	3-2
Airbag Deployment Interference .....	3-6
Roof Bow Locations .....	3-7
Areas to Avoid When Choosing Mounting Locations .....	3-8
<b>Component Location and Identification — High Voltage Vehicles</b> .....	3-8
Brake System Components .....	3-10

## Section 3: Mounting

### Section 3: Mounting

#### Push Bumpers

Ford Motor Company does not recommend the installation of any type of push bumper.

#### Cooling System Note

**NOTICE:**

**Do not modify the cooling system. High voltage vehicle components may be damaged if any cooling system modifications are attempted.**

The cooling system relies on proper airflow through the radiator to keep components at their proper operating temperature. When adding equipment to a vehicle, make sure the airflow is not obstructed. Reduced airflow could put additional strain on the cooling system and shorten the operational life of related components. The cooling system also cools the electric motors and electronics. If the coolant exceeds certain temperatures, the components will attempt to protect themselves by limiting the power and torque available. During the installation process, keep the placement of components away from the grille area of the vehicle.

#### Mounting Equipment to the Vehicle

- Do not mount equipment to the high voltage (orange) wiring/cables or the high voltage cover, or any other high voltage components.
- Do not mount equipment on the instrument panel between the driver and passenger airbags due to deployment variability.
- Do not mount equipment on the instrument panel between the driver and the pedals, between the door and the console area due to knee airbag deployment variability.
- Do not mount equipment obstructing the High Voltage Battery pack service disconnect located under the hood, LH side of the engine compartment.
- Do not remove or block the High Voltage Battery pack cooling system components. These components are necessary for the proper cooling of the HVTB.
- Do not cover any warning or vehicle labels.
- **NOTICE:**  
**The side impact sensors are tuned to excite based on their mass (including wiring), as well as the host sheet metal. Any alteration to these components must be avoided. Additions such as padding, wire connectors, retainers, tape or fasteners of any kind should not be used. All fasteners in this predominantly sheet metal environment should be made of steel or a non-conductive plastic to guarantee retention and longevity. If any part of a steel fastener is exposed to a wet area, it should be plated to resist corrosion.**
- Do not mount equipment to the A, B, C, or D-pillars.
- Do not mount equipment on the headliner within 200 mm (8 in) of the side edges.
- Do not mount equipment above the beltline within 200 mm (8 in) of the side glass from the A-pillar leading edge to the rear edge of the D-pillar.
- Do not mount equipment on the headliner along the siderails.
- Do not install a partition, divider or equipment that spans the vehicle above the beltline.

#### Airbag, Safety Restraint System and Side Impact Sensor Component Description and Location

The safety belt retractors are located in the base of the B-pillars. The pretensioner located in the retractor is referred to as the safety belt retractor pretensioner. In the event the Restraints Control Module (RCM) senses an impact, pretensioners provide improved occupant protection by rapidly removing slack from the safety belt. Removing slack from the safety belt helps to properly position the occupant and allows for maximum effectiveness of the safety belts and the airbags.

- Do not use the safety belt retractor bolts for mounting the partition.
- Do not mount any partition hardware on the inboard side of the B-pillar within the bottom 305 mm (12 in).
- Do not mount any partition hardware that will interfere with the proper sealing of the door.

The side impact sensors are located in the front doors and C-pillars; one sensor in each door and in each C-pillar. The location and orientation are critical for the correct operation of all the impact sensors. Do not use the attachment bolts of the impact sensors to mount any equipment.

The RCM is mounted under the front of the center console. The RCM orientation is critical for proper operation of the restraint systems. Do not relocate or use the RCM mounting bolts for attachment purposes of any equipment.

Various safety restraints exist within the vehicle, the restraint system includes various modules, sensors, retractors, airbags and the safety belt systems. Refer to the workshop manual for more detail on the safety restraint system.

## Section 3: Mounting

**NOTE:**

Airbag, safety restraint system and side impact sensor component location shown below.

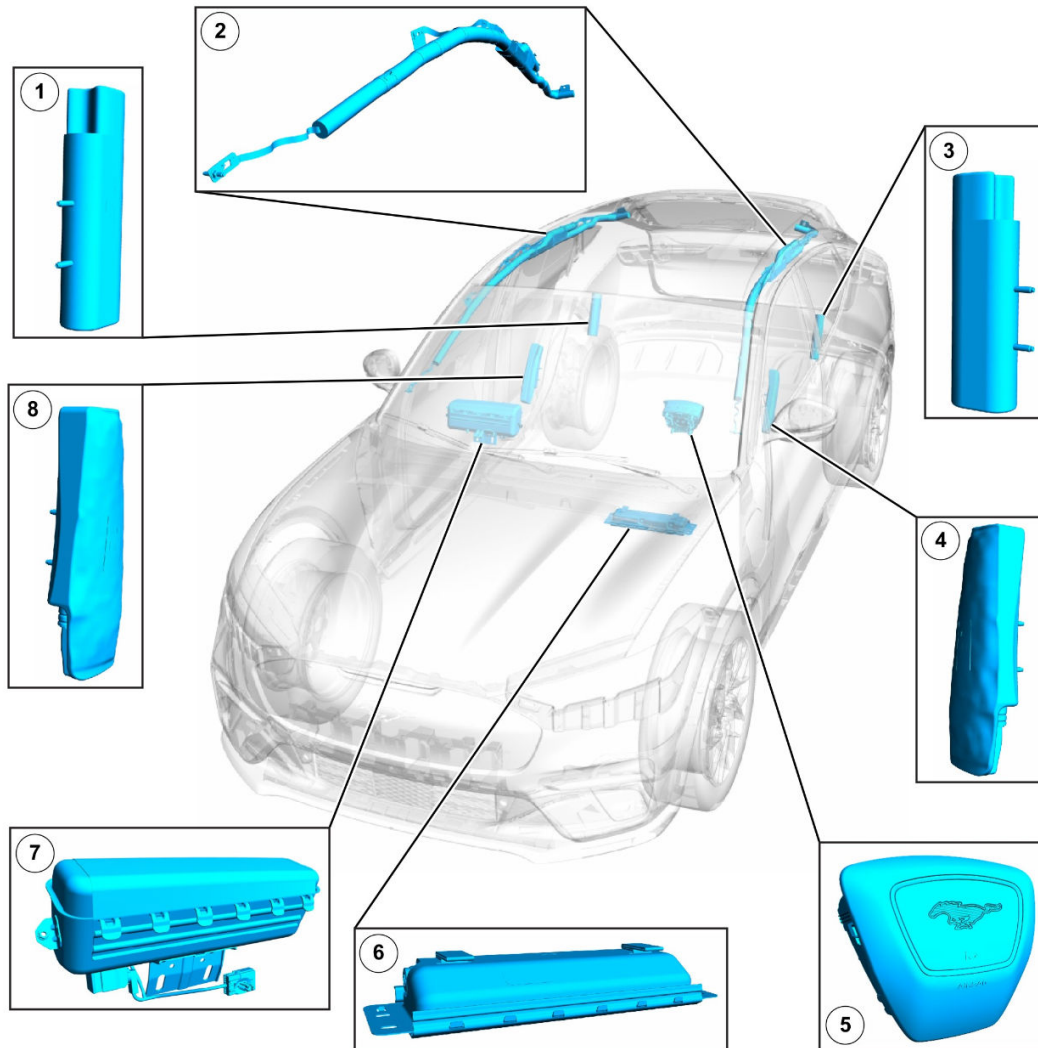

N0183284

Item	Description
1	Second row passenger seat side airbag
2	Driver/passenger side curtain airbag
3	Second row driver seat side airbag
4	Driver side airbag
5	Driver Airbag
6	Driver knee airbag
7	Passenger airbag (includes canister vent)
8	Passenger side airbag

## Section 3: Mounting

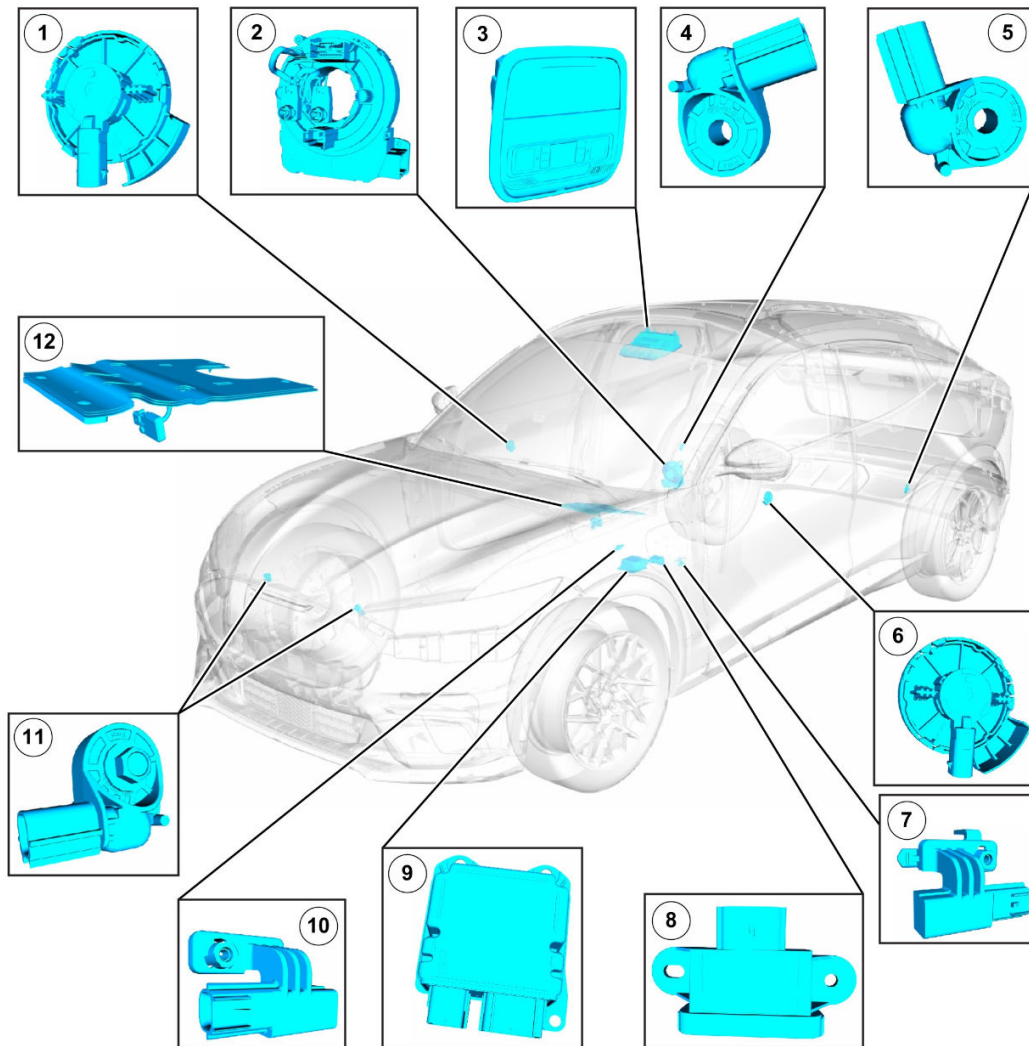

N0183285

Item	Description
1	Passenger front door side impact sensor
2	Clockspring
3	PAD (passenger airbag deactivation) indicator
4	Passenger side C-pillar side impact sensor
5	Driver side C-pillar side impact sensor
6	Driver front door side impact sensor
7	Driver seat position sensor
8	BECMB (battery energy control module B)
9	RCM (restraints control module)
10	Passenger seat position sensor
11	Driver and passenger front impact severity sensors
12	OCSM (occupant classification system module) (includes OCS (occupant classification system) sensor and gel-filled bladder)

### Section 3: Mounting

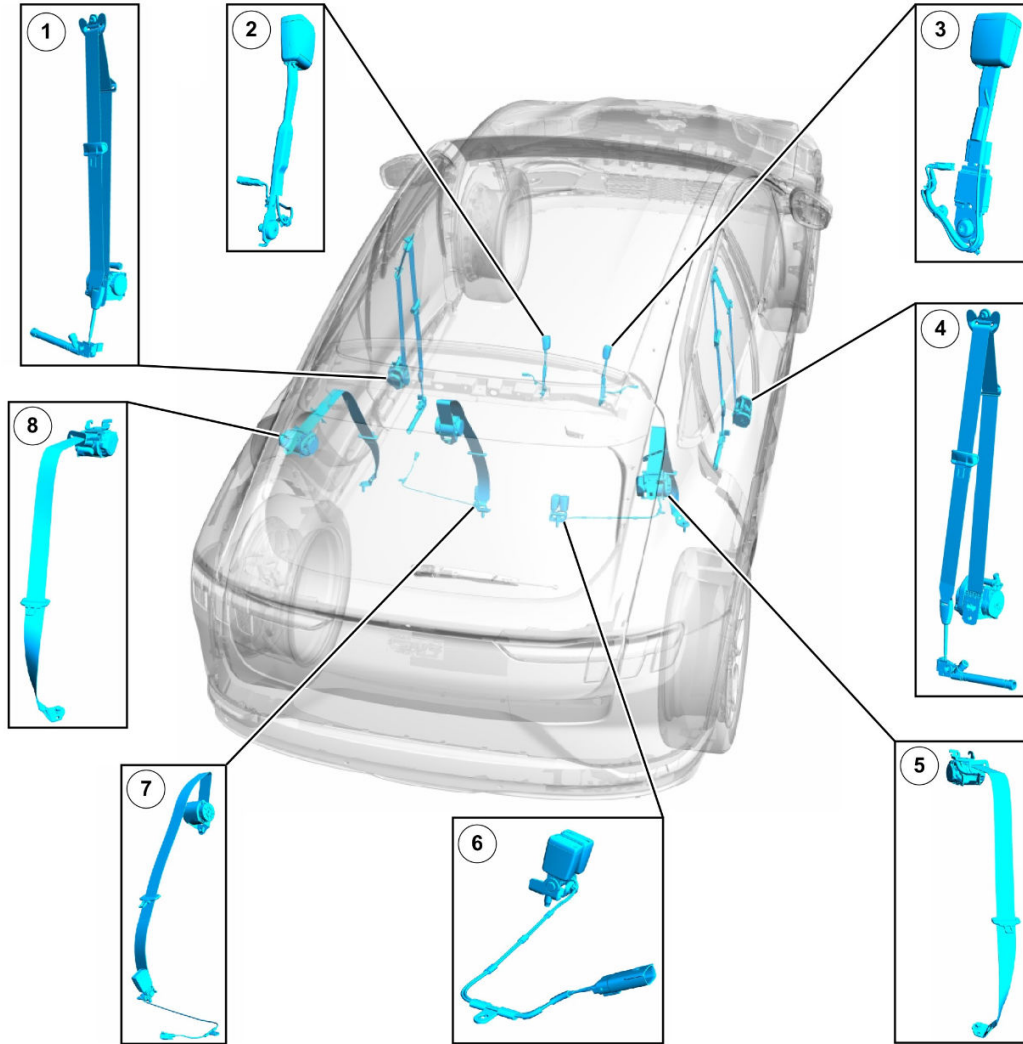

N0183286

Item	Description
1	Driver seatbelt retractor (includes retractor pretensioner and anchor pretensioner)
2	Driver seatbelt buckle (includes buckle sensor)
3	Front passenger seatbelt buckle (includes buckle sensor and Belt Tension Sensor (BTS))
4	Front passenger seatbelt retractor (includes retractor pretensioner, retractor load limiter and anchor pretensioner)
5	Rear passenger side outer seatbelt retractor (includes retractor pretensioner)
6	Rear passenger side outer and center seatbelt buckles (includes seatbelt buckle switch)
7	Rear driver side outer seatbelt buckle (includes seatbelt buckle switch)
8	Rear driver side outer seatbelt retractor (includes retractor pretensioner)

## Section 3: Mounting

### Airbag Deployment Interference

 **WARNING:**

Do not place objects or mount equipment in front of the airbag module cover or in the front seat area; this is to avoid contact with a deploying airbag. Placing objects on or over the airbag inflation area may cause those objects to be propelled by the airbag. Failure to follow these instructions may result in personal injury.

 **WARNING:**

Dash, tunnel or console-mounted equipment should be placed only within their specified zone. Failure to follow this instruction may result in personal injury.

 **WARNING:**

Do not mount equipment between the side of the front seat and the door trim that would block deployment of the side airbag. Failure to follow this instruction may result in personal injury.

 **WARNING:**

Do not mount equipment on the instrument panel between the driver and the pedal area, between the door and the console that may come in contact with or block a deploying knee airbag. Failure to follow this instruction may result in personal injury.

 **WARNING:**

Do not attempt to service, repair or modify the airbag supplemental restraint systems (SRS) or its fuses. See your Ford or Lincoln dealer. Failure to follow this instruction may result in personal injury.

 **WARNING:**

Modifications to the front end of the vehicle, including frame, bumper, front end body structure, tow hooks and B-pillar surrounding parts may affect the performance of the airbag sensors, increasing the risk of injury. Do not modify the front end of the vehicle.

 **WARNING:**

Do not place objects or mount equipment on or near the headliner at the siderail that may come into contact with a deploying Safety Canopy® System. Failure to follow this instruction may increase the risk of personal injury in the event of a collision.

 **WARNING:**

Do not attempt to service, repair or modify the Safety Canopy® System, its fuses, the A, B, C, or D-pillar trim, or the headliner on a vehicle containing a Safety Canopy® System. See your Ford or Lincoln dealer.

 **WARNING:**

To reduce risk of injury, do not obstruct or place objects in the deployment path of the inflatable Safety Canopy® System.

**NOTICE:**

The side impact sensors are tuned to excite based on their mass (including wiring), as well as the host sheet metal. Any alteration to these components must be avoided. Additions, such as padding, wire connectors, retainers, tape or fasteners of any kind should not be used. All fasteners in this predominantly sheet metal environment should be made of steel or a non-conductive plastic to guarantee retention and longevity. If any part of a steel fastener is exposed to a wet area, it should be plated to resist corrosion.

Driver/passenger airbags affect the way equipment can be mounted in vehicles. Any surfaces that could come into contact with an airbag during deployment must not damage the airbag or alter its deployment path. Sharp edges, corners or protrusions could damage the nylon airbag material and reduce the effectiveness of the airbag. Do not mount or place any objects in the deployment path of an airbag. Airbags must be allowed to fully deploy without restriction. The deployment of airbags is not compatible with any configuration of equipment mounting that places objects in the airbag deployment path. Equipment mounted or placed in the deployment area of an airbag will reduce the effectiveness of the airbag, damage the airbag and potentially damage or dislodge the equipment.

Airbag deployment drawings are provided in Section 7. Consult the drawings before equipment is installed inside the passenger compartment to make sure that the mounted equipment does not interfere with airbag deployment.

## Section 3: Mounting

### Roof Bow Locations

Mach-E without sunroof opening shown

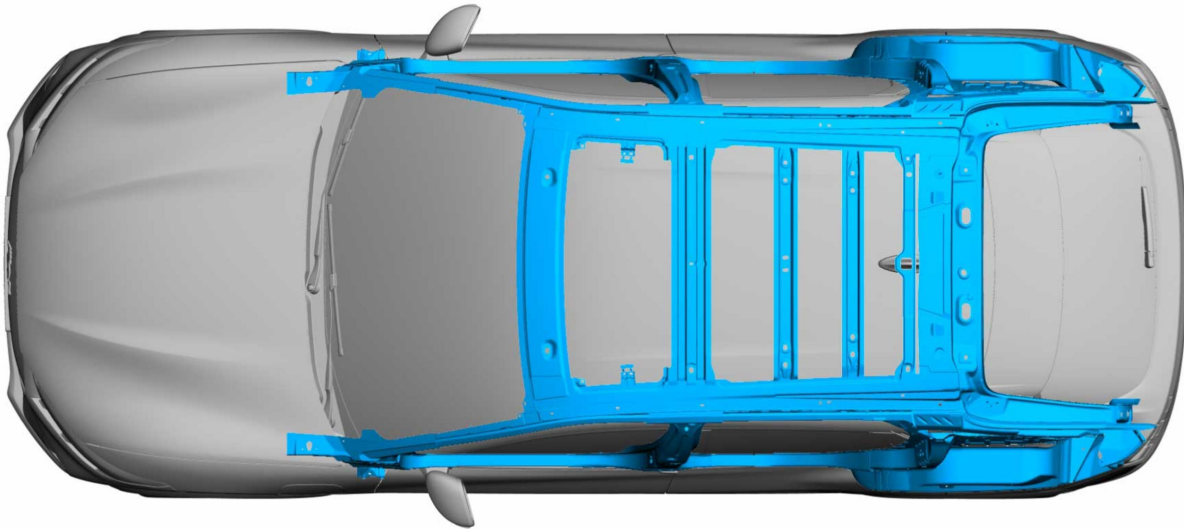

N0183289

Mach-E with sunroof opening shown



N0183288

### Areas to Avoid When Choosing Mounting Locations

The following illustrations show locations to avoid when choosing components mounting locations, these locations include: High Voltage Components and Cables, Fuel System Components, Brake System Components, and Exhaust Components. To avoid personal injury or damage to vehicle systems avoid drilling or mounting of components in these areas.

## Section 3: Mounting

### Component Location and Identification — High Voltage Vehicles

The following illustrations provide the location, description and basic function of the High Voltage system components.

**NOTE:**

All High Voltage wires and harnesses are orange in color.

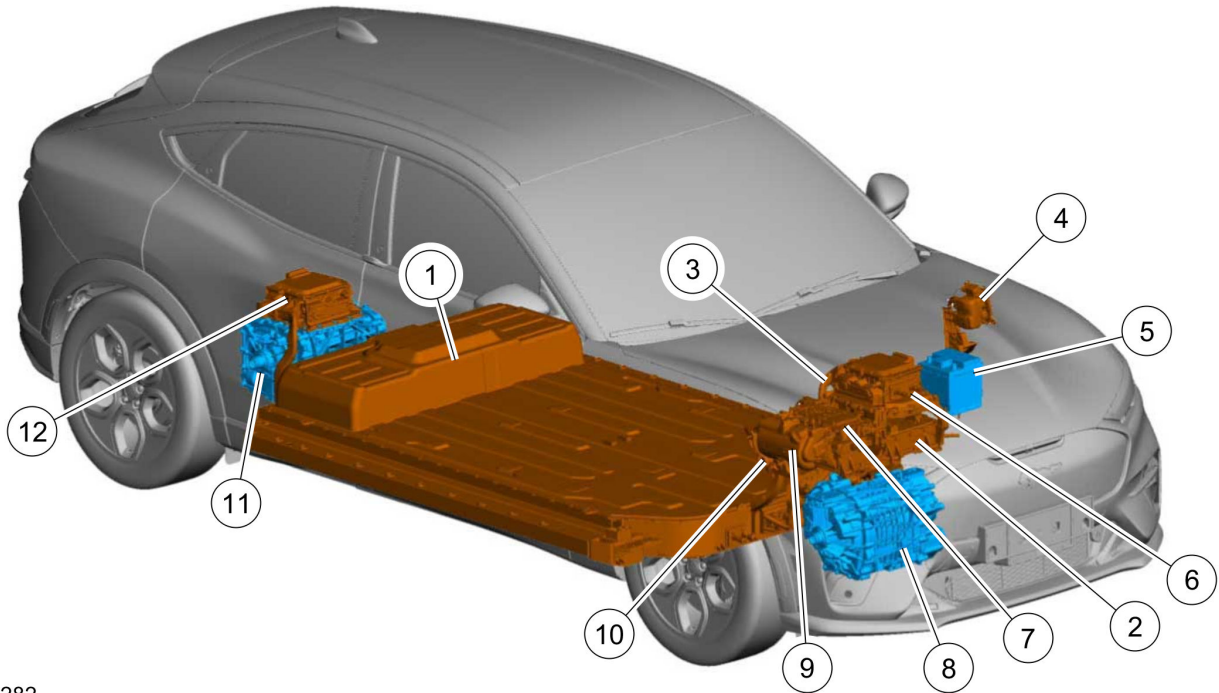

N0183282

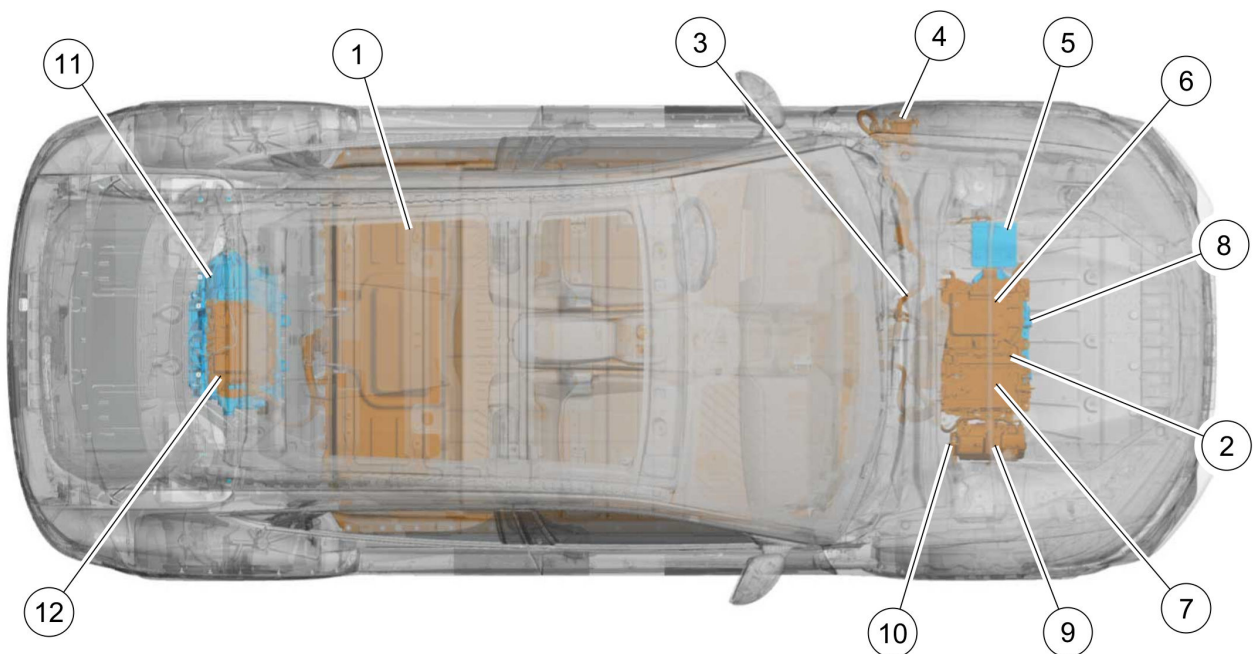

N0183283

## Section 3: Mounting

CALLOUT	COMPONENT	LOCATION / DESCRIPTION	FUNCTION
1	High Voltage Battery — Approximately up to 450 Volts DC	Located under the vehicle. Liquid cooled lithium ion battery.	Provides High Voltage storage for the vehicle electric motors and for the other High Voltage components.
2	Charge Unit	Located under the vehicle directly forward of the high voltage battery.	To charge High Voltage battery.
3	High Voltage Wiring	Runs underneath the vehicle from rear electric drive assembly to the front electric drive assembly. All High Voltage wiring is orange in color.	Provides High Voltage for the vehicle electric motors and for the other High Voltage components.
4	High Voltage Battery Charging Port	Located in the left hand front fender.	Allows High Voltage battery charging using suitable charging stations.
5	12 Volt Battery	Located in the engine on the left hand side next to the charge unit.	The battery is a 12V DC source connected in a negative ground system and is a voltage stabilizer for the 12V electrical system.
6	Inverter System Controller (ISC)	Located under the hood mounted on top of the charge unit and next to the power converter.	To convert AC power to DC and controls the front electric drive assembly speed.
7	DC/DC Converter	Located under the hood mounted on top of the charge unit and next to the Inverter System Controller (ISC).	Provides 12 volts to charge the 12-volt battery and run accessories.
8	Front Electric Drive Assembly	Located under the vehicle centered between the front wheels.	To provide power to the front wheels.
9	Electric A/C Compressor	Located in the engine on the right hand side next to the charge unit. It has an orange high-voltage wire attached to it.	Provides electric A/C operation. Replaces the belt driven A/C compressor.
10	Electric Heater	Located in the engine on the right hand side between the high voltage battery and the charge unit.	Heats the coolant to provide the passenger compartment with consistent heat.
11	Rear Electric Drive Assembly	Located under the vehicle centered between the rear wheels.	To provide power to the rear wheels.
12	Inverter System Controller (SOBDMB)	Located in the rear cargo area.	To convert AC power to DC and controls the rear electric drive assembly speed.

## Section 3: Mounting

### Brake System Components

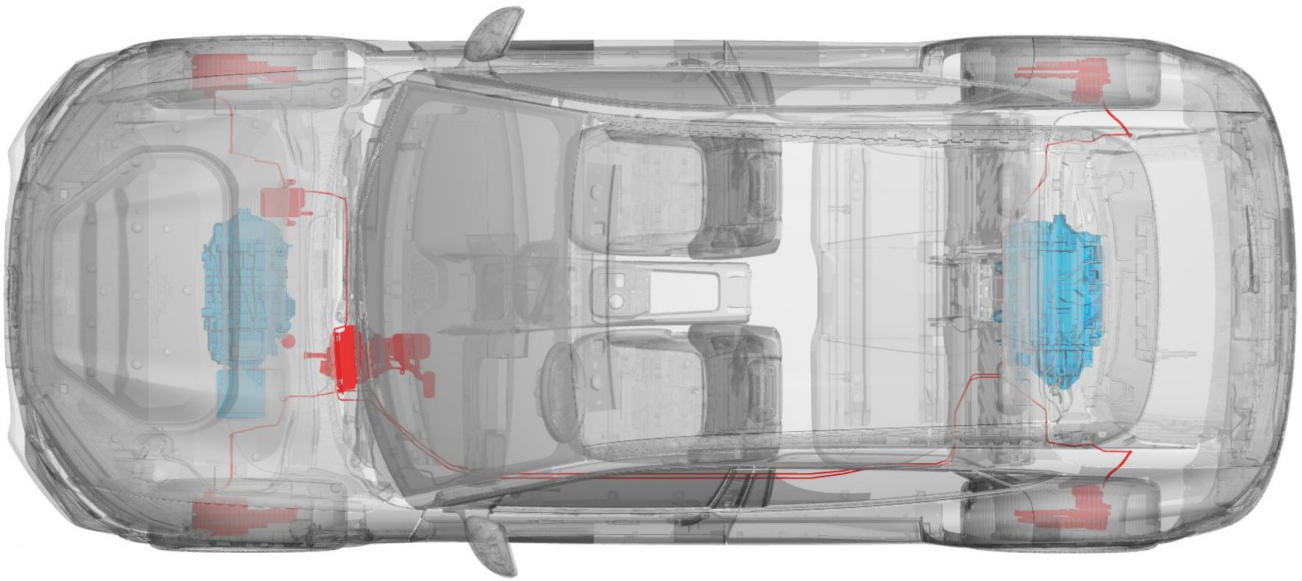

N0183442

## SECTION 4: Airbag Deployment Interference Zones

---

### Table of Contents

Contents	PAGE
Section 4: Airbag Deployment Interference Zones .....	4-2
Airbag Deployment Interference Zones .....	4-2

## Section 4: Airbag Deployment Interference Zones

### Section 4: Airbag Deployment Interference Zones

#### Airbag Deployment Interference Zones

 **WARNING:**

Do not place objects or mount equipment in front of the airbag module cover or in the front seat area; this is to avoid contact with a deploying airbag. Placing objects on or over the airbag inflation area may cause those objects to be propelled by the airbag. Failure to follow these instructions may result in severe personal injury or death.

 **WARNING:**

Dash, tunnel or console-mounted equipment should be placed only within their specified zone. Failure to follow this instruction may result in severe personal injury or death.

 **WARNING:**

Do not mount equipment between the side of the front seat and the door trim that would block deployment of the side airbag. Failure to follow this instruction may result in personal injury.

 **WARNING:**

Do not attempt to service, repair or modify the airbag supplemental restraint systems (SRS) in any way. Failure to follow this instruction may result in severe personal injury. See your Ford or Lincoln dealer.

 **WARNING:**

Modifications to the front end of the vehicle, including frame, bumper, front end body structure, tow hooks and B-pillar surrounding parts may affect the performance of the airbag sensors, increasing the risk of injury. Do not modify the front end of the vehicle. Failure to follow these instructions may result in severe personal injury or death.

 **WARNING:**

Do not place objects or mount equipment on or near the headliner at the siderail that may come into contact with a deploying safety canopy. Failure to follow this instruction may increase the risk of personal injury in the event of a collision.

 **WARNING:**

Do not attempt to service, repair or modify the Safety Canopy® System, its fuses, the A, B, C, or D-pillar trim, or the headliner on a vehicle containing a Safety Canopy® System. See your Ford or Lincoln dealer. Failure to follow these instructions may result in personal injury.

**NOTICE:**

The side impact sensors are tuned to excite based on their mass (including wiring), as well as the host sheet metal. Any alteration to these components must be avoided. Additions, such as padding, wire connectors, retainers, tape or fasteners of any kind should not be used. All fasteners in this predominantly sheet metal environment should be made of steel or a non-conductive plastic to guarantee retention and longevity. If any part of a steel fastener is exposed to a wet area, it should be plated to resist corrosion.

Driver/passenger airbags affect the way equipment can be mounted in vehicles. Any surface that could come into contact with an airbag during deployment must not damage the airbag or alter its deployment path. Sharp edges, corners or protrusions could damage the nylon airbag material and reduce the effectiveness of the airbag. Do not mount or place any objects in the deployment path of an airbag. Airbags must be allowed to fully deploy without restriction. The deployment of airbags is not compatible with any configuration of equipment mounting that places objects in the airbag deployment path. Equipment mounted or placed in the deployment area of an airbag will reduce the effectiveness of the airbag, damage the airbag and potentially damage or dislodge the equipment.

Some approximate dimensions for airbags, at full inflation, are provided. These dimensions are somewhat flexible and represent free-form deployments without the loading of occupants. The zone dimensions provided are approximate and will vary with the loading of occupants in the seats.

All airbag and equipment mounting zone dimensions are approximate due to different airbag deployment characteristics.

Do not mount equipment between the side of the front seat and the door trim that would block deployment of the side airbag.

## Section 4: Airbag Deployment Interference Zones

Do not mount equipment on the instrument panel between the driver and passenger airbags due to deployment variability.

Equipment must not interfere with driver visibility.

- Do not mount equipment to the A, B, C and D-pillars.
- Do not mount equipment on the headliner within 200 mm (8 in) of the side edges.
- Do not mount equipment above the beltline within 200 mm (8 in) of the side glass from the A-pillar leading edge to the rear edge of the D-pillar.
- Do not mount equipment on the headliner along the siderails.
- Do not mount equipment to the driver side kick panel located below the steering column. The driver knee airbag is located behind this panel.

*Driver and Passenger Air Bag*

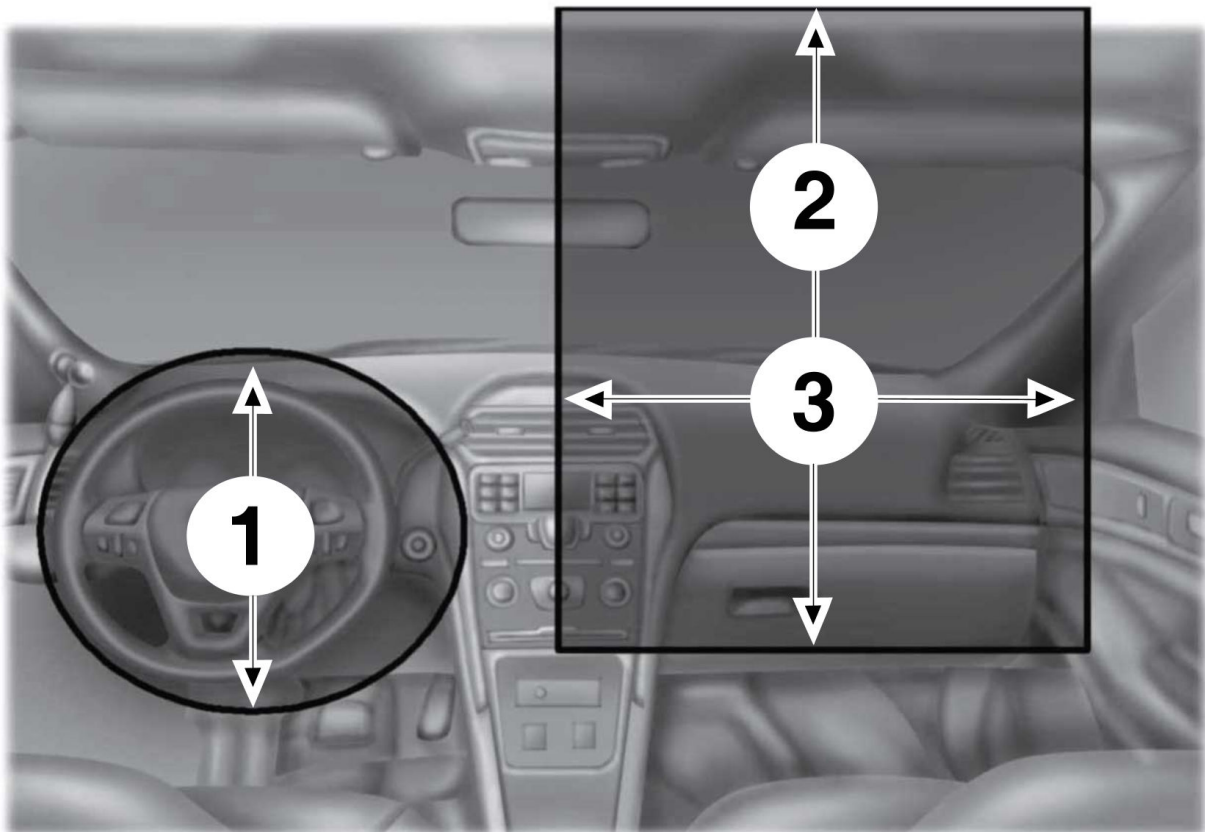

N0181796

1. 550 mm (21.6 in)
2. 675 mm (26.5 in)
3. 545 mm (21.4 in)

## Section 4: Airbag Deployment Interference Zones

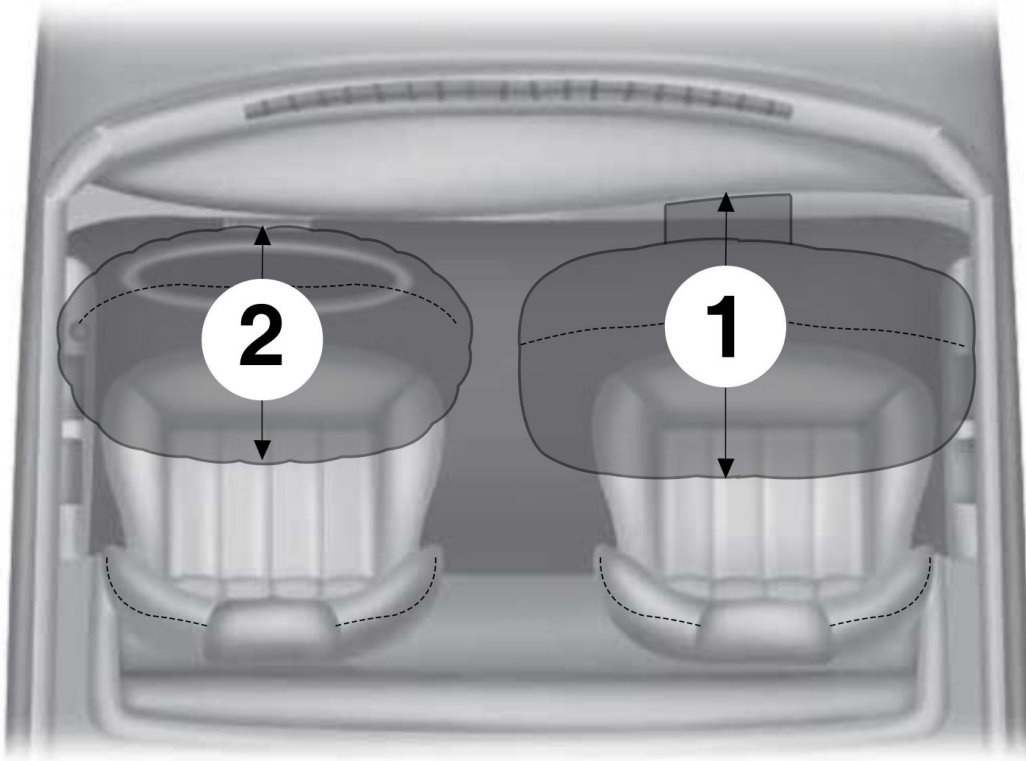

N0179719

1. 707 mm (27.8 in) Front passenger airbag.
2. 350 mm (13.7 in) Front driver airbag.

# Section 4: Airbag Deployment Interference Zones

Driver Knee Air Bag

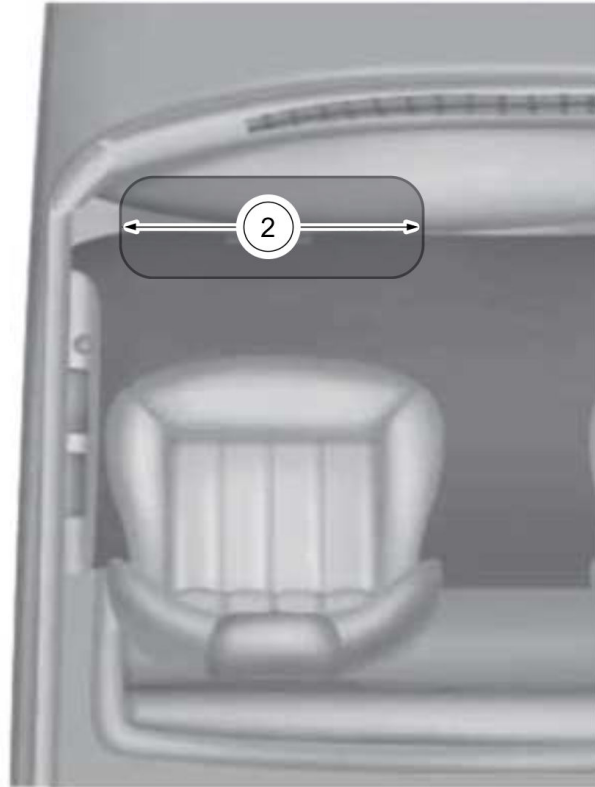

N0182316

- 1. 267 mm (10.5 in)
- 2. 552 mm (21.7 in)

The side airbags are located on the outboard side of the seatbacks of the front seats. In certain sideways crashes, the airbag on the side affected by the crash will be inflated. The airbag was designed to inflate between the door panel and occupant to further enhance the protection provided occupants in side impact crashes.

**Section 4: Airbag Deployment Interference Zones**

*Driver and Passenger Side Seat Airbag*



N0179736

## Section 4: Airbag Deployment Interference Zones

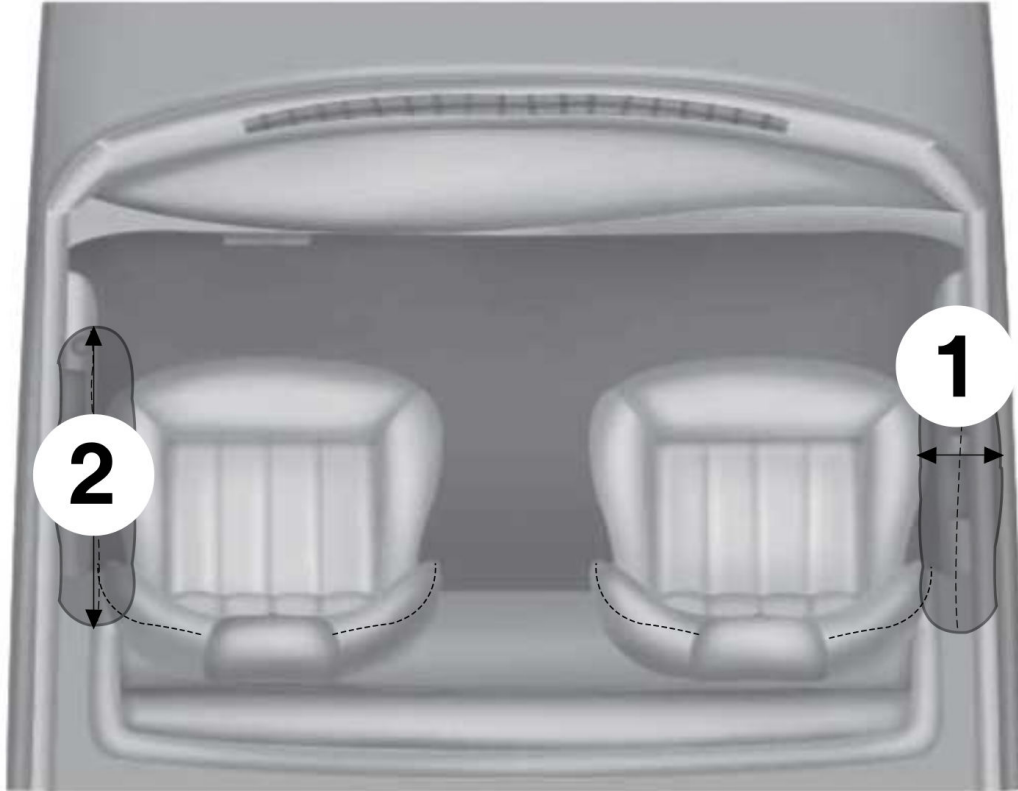

N0179720

- 1. 70 mm (2.7 in) From outboard side of seat.
- 2. 615 mm (24.2 in) Forward of seatback.

## Section 4: Airbag Deployment Interference Zones

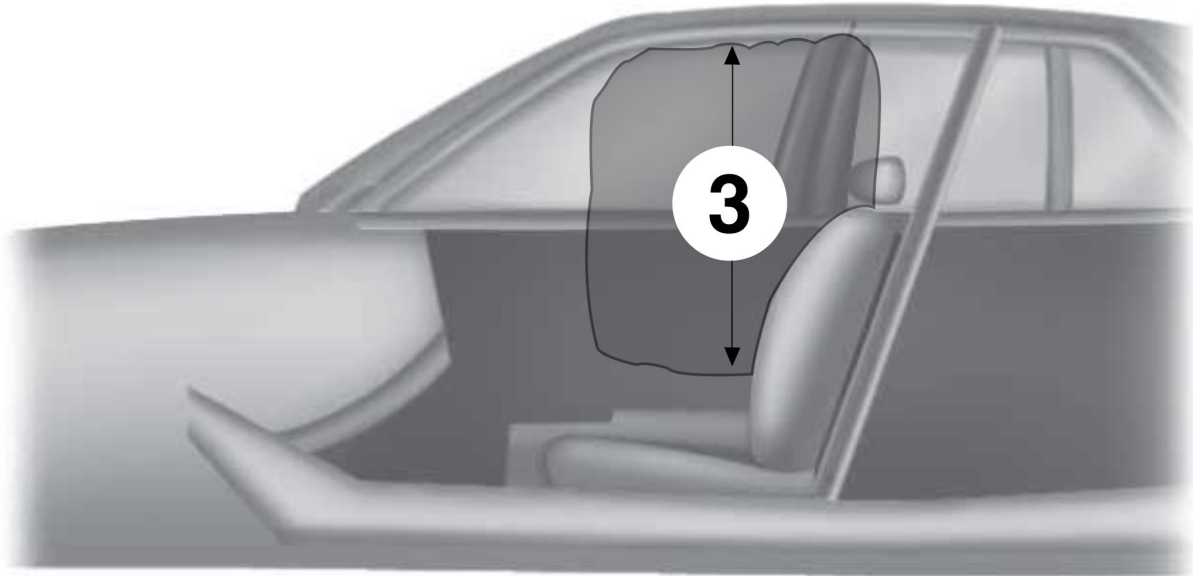

N0179721

### 3. 555 mm (21.8 in) Up from side airbag module

The Safety Canopy will deploy during significant side crashes or when a certain likelihood of a rollover event is detected by the rollover sensor. The Safety Canopy is mounted to the roof side-rail sheet metal, behind the headliner, above each row of seats. The Safety Canopy curtain airbags above the trim panels over the front and rear side windows identified by a label or wording on the headliner or roof pillar trim. In certain sideways crashes or rollover events, the Safety Canopy will be activated, regardless of which seats are occupied. The Safety Canopy is designed to inflate between the side window area and occupants to further enhance protection provided in side impact crashes and rollover events.

# Section 4: Airbag Deployment Interference Zones

Side Curtain Airbag

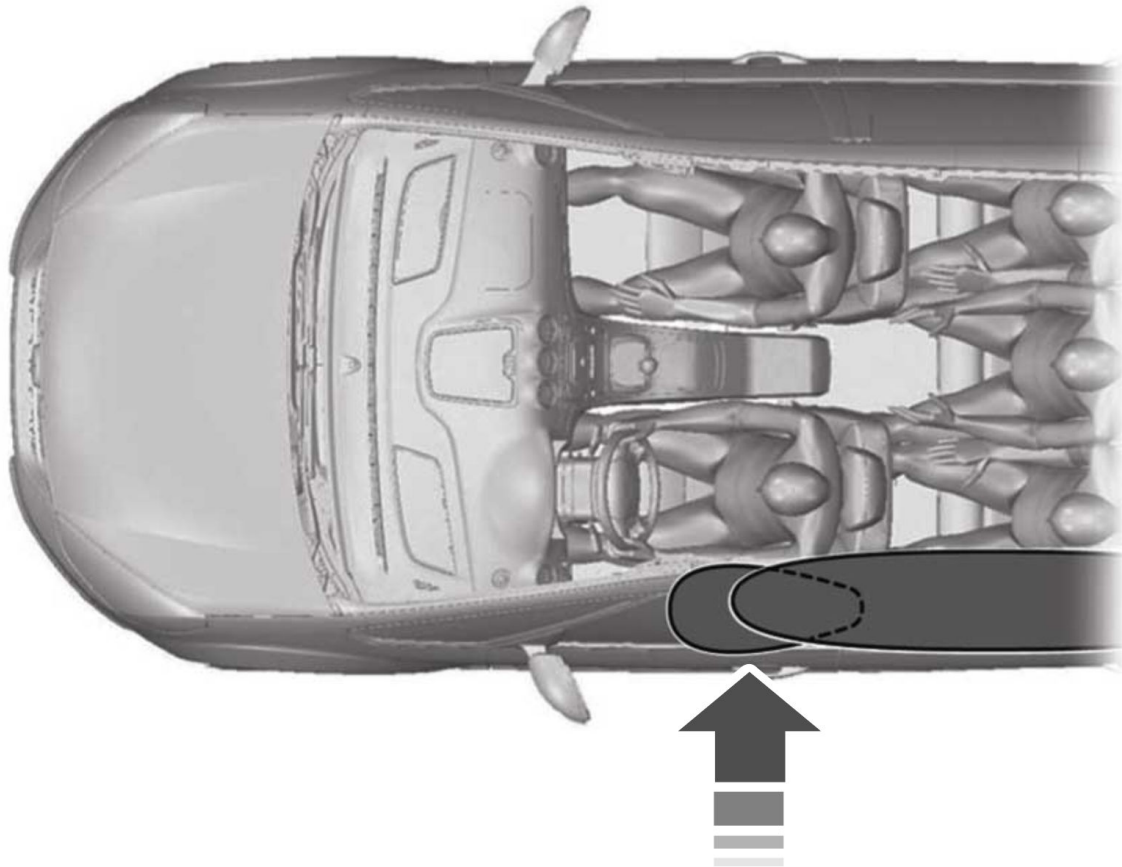

N0179717

**NOTICE:**

Any surfaces that could come into contact with side air curtain (Safety Canopy® System) during deployment must not damage the curtain. Sharp edges, corners or protrusions could damage the curtain and reduce the overall effectiveness of the side air curtain.

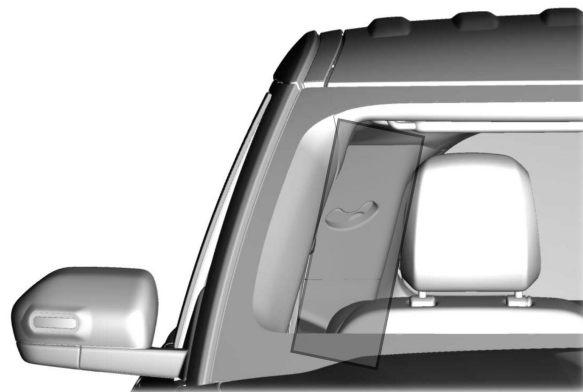

N0179839

165 mm (6.45 in) from pillar trim (A through D)

## Section 4: Airbag Deployment Interference Zones

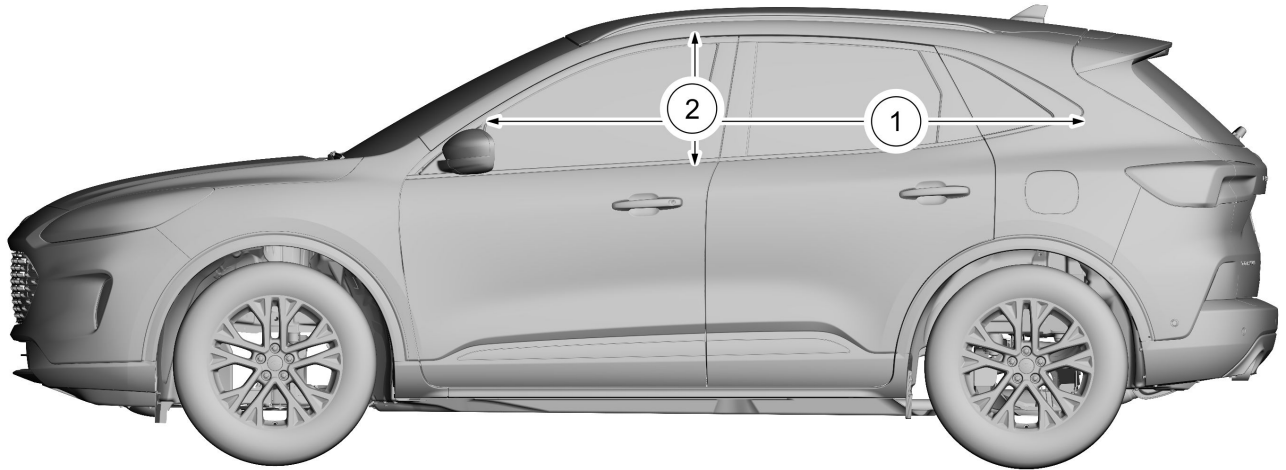

N0181797

1. 1720 mm (67.7 in)

2. 385mm (15.1 in)