

FORD E-Transit
2022 - 2023

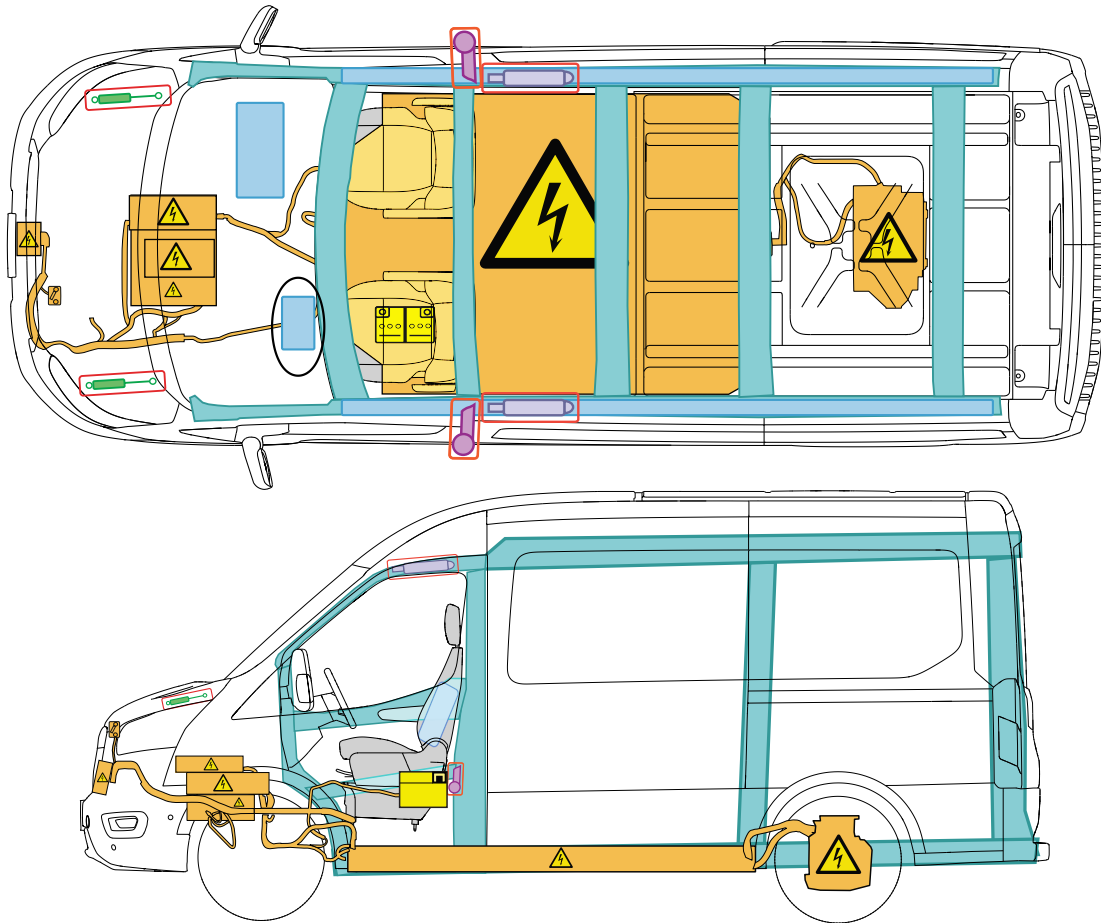

Legend

	Airbag		Structural Reinforcements		Control unit		High-voltage battery		High-voltage disconnection point
	Gas generator		Gas filled spring device		Battery		High-voltage wire / components		Fuel tank
	Seat belt tensioner								



1. Identification / recognition



1. Vehicle Identification Number (VIN)
2. Charging port and blue striping on front grill. E-Transit badging on left rear door.

Vehicle Identification Number (VIN) Layout

The 8th position of the VIN identifies the vehicle's engine type as electric.

- K - BEV (battery electric vehicle), (Electric motor #1)

Sample VIN

BEV - 1FBAE2CK4NKE16974



2. Immobilization / stabilization / lifting

IMMOBILIZATION

1. Position Wheel And Tire Chocks

2. Put vehicle into Park position (1)
Ensure parking brake is engaged (2)

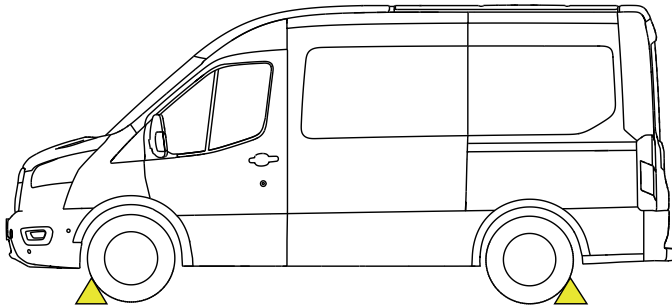

STABILIZATION / LIFTING

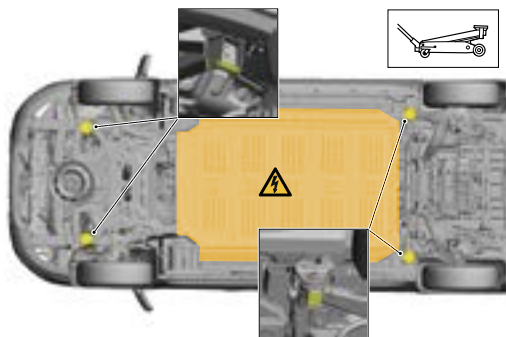

Medium Wheelbase [MWB] - Van, Bus, Kombi

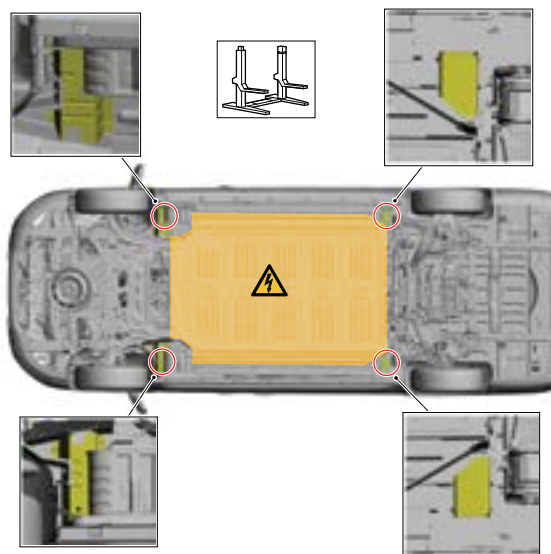

Long Wheelbase [LWB] - Van, Bus, Kombi

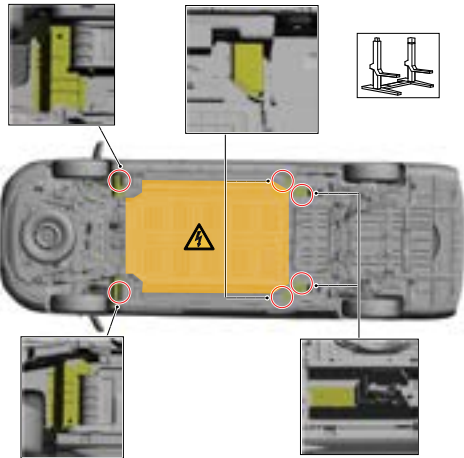

Extra Long Wheelbase [LWB-EL] - Single Chassis Cab and Jumbo

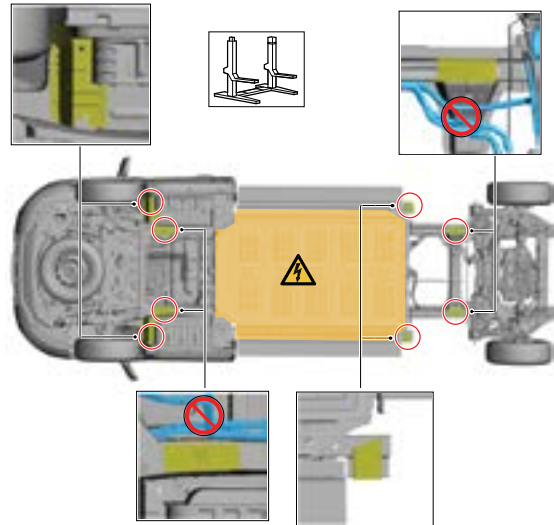

3. Disable direct hazards / safety regulations

NOTE: Perform as many of these steps as able to ensure the high voltage system is disabled.

1. Ensure the vehicle transmission gear selector is in the PARK position. Check that the vehicle READY light is off to verify the high voltage system is disconnected. If the vehicle READY light is on, press the engine Start/Stop button to turn off the ignition.
2. Release and position the LH front seat forward.



3. Release the retainers and remove the LH front seat rear trim panel.

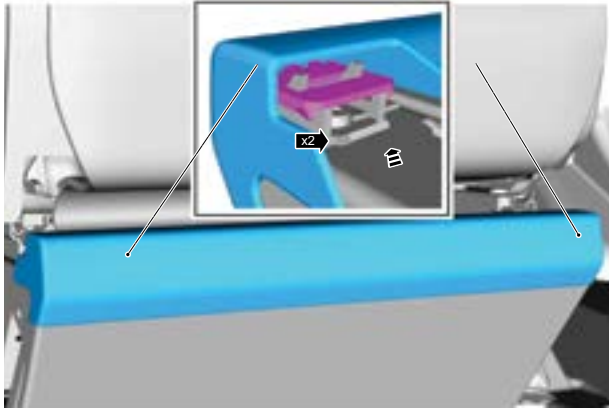

Single Battery

4. Position the LH front seat backrest cover and release a retainer (1). Position the LH front seat backrest cover (2).

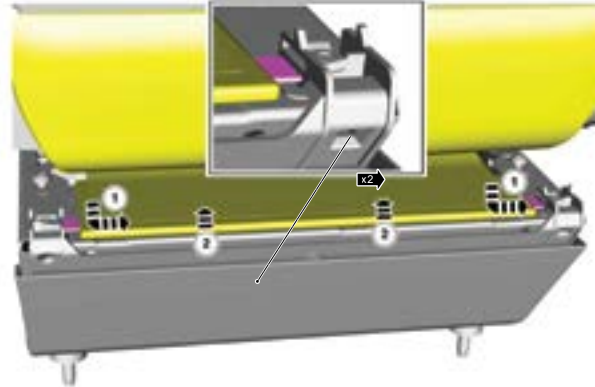

Dual Battery

5. If equipped, position the battery cover insulator (1). Remove the battery disconnect access cover (2).

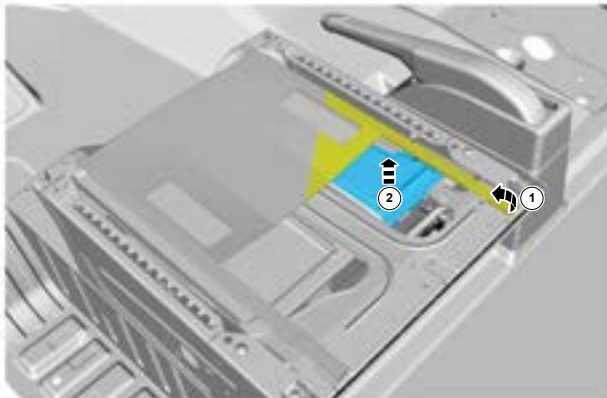

5. If equipped, position the battery cover insulator (1). Remove the battery disconnect access cover (2).

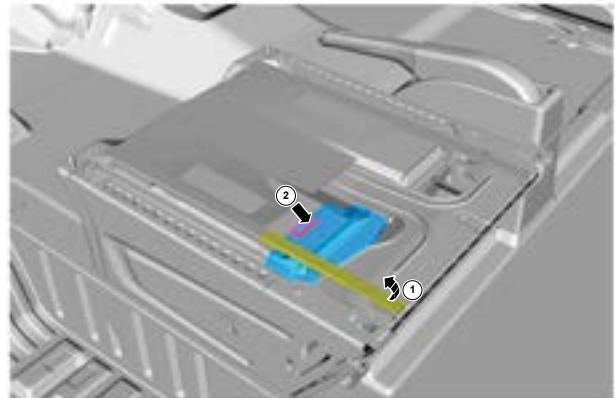

6. Remove the nut and position the battery cable. Torque 71 lb. in (8 Nm)

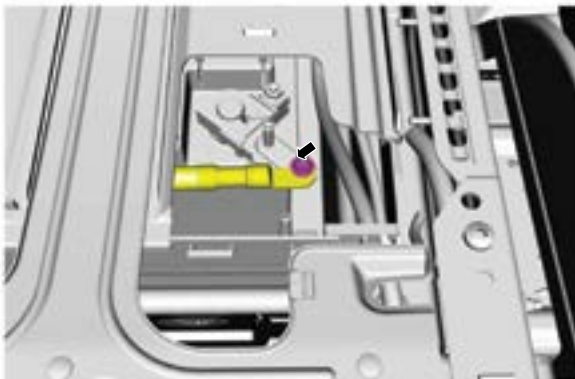

6. Remove the nut and position the battery cable. Torque 71 lb. in (8 Nm)

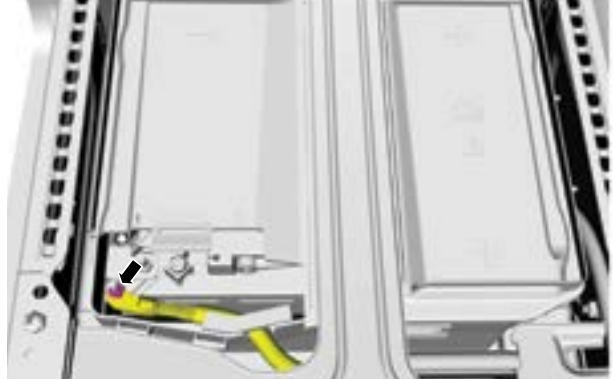

7. Detach the pin-type retainer and position the electrical connector and wiring harness aside.

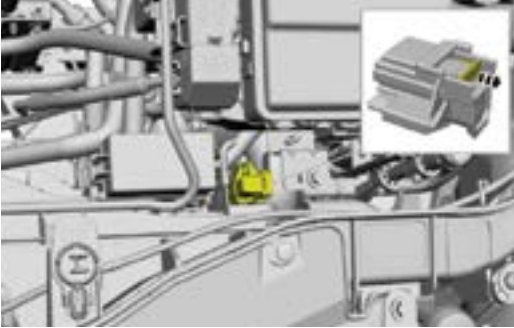

9. **NOTE:** The tab must be depressed prior to pushing the connector back in or damage to the connector may result.

Depress the tab while pulling the connector until the hole is completely visible on the top of the connector.

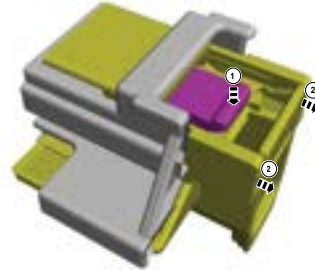

8. Release the Connector Position Assurance (CPA) clip.

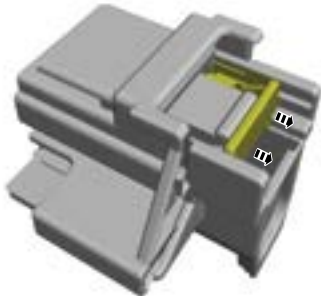

10. Insert a suitable tool inside the connector hole to prevent the connector from closing.



11. Wait a minimum of 5 minutes.

4. Access to the occupants

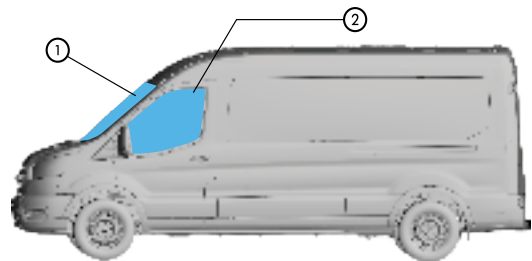
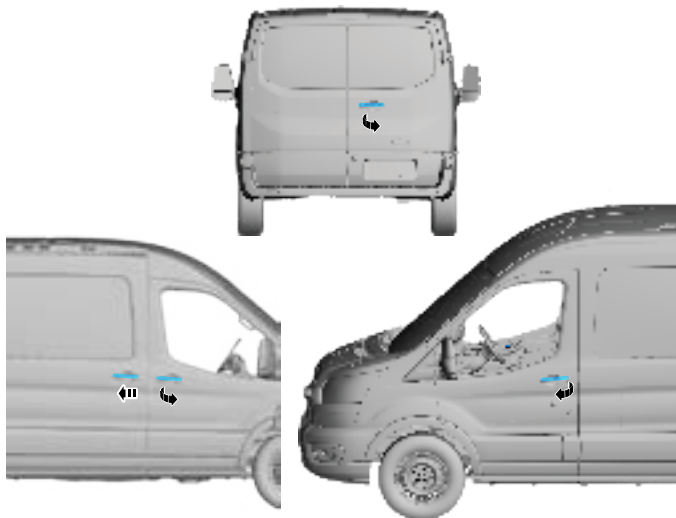

- ① Laminated Safety Glass
- ② Toughened Safety Glass



5. Stored energy / liquids / gases / solids

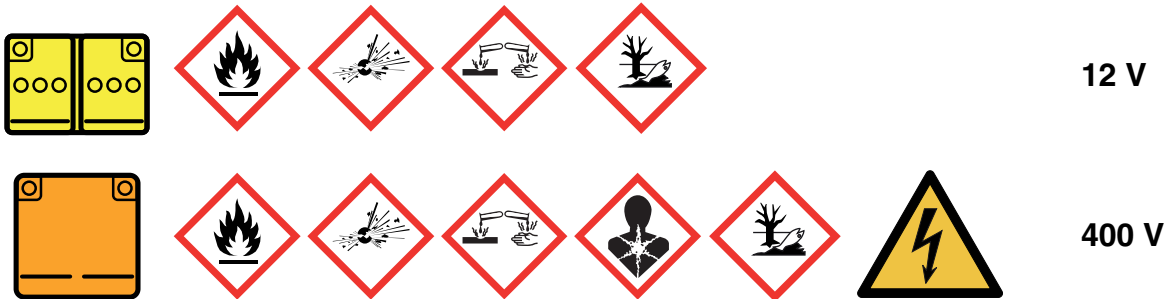

Refer to the vehicle overview illustration on Page 1 for location reference of the high voltage battery, 12V battery, gas tank, and other vehicle component locations.

6. In case of fire



If the vehicle is on fire, use a Class ABC powder-type extinguisher to contain and smother the flames. If water is being used, LARGE amounts of water is required to extinguish the flames. A fire-hydrant or dedicated fire hose can supply the needed amount. Water can cause some degree of arcing/shorting across the cell and/or battery terminals; it can also react with the electrolyte from the cells to generate additional combustible gas and other byproducts such as hydrofluoric acid. However, the cooling and smothering effects of flushing the affected article with large amounts of water and/or other fire suppression material is still beneficial for minimizing the severity of the event.

7. In case of submersion

If the vehicle is submerged in water, varying degrees of arcing/shorting within the battery will take place. Do not touch any High Voltage components or orange cables while removing the occupant(s). Do not remove the vehicle until you are sure the High Voltage battery is completely discharged. A submerged High Voltage battery may produce a fizzing or bubbling reaction to the water. If fizzing or bubbling is observed, the High Voltage battery will be discharged when the fizzing or bubbling has completely stopped. The battery should still be treated as if it is not discharged.

Battery Electric and Hybrid vehicles when submerged should only be handled while wearing the appropriate Personal Protective Equipment (PPE) for water rescue and vehicle extraction.



8. Towing / transportation / storage

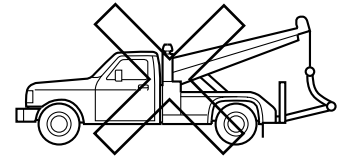
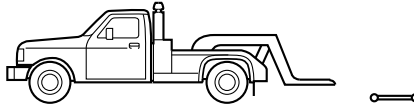
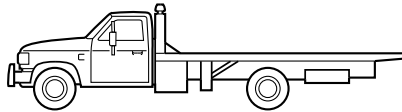

NOTICE: Do not attempt to pull / tow vehicle with wheels on the ground as this may cause the vehicle to generate electricity and can cause potential damage.

NOTE: Front-wheel and rear-wheel drive vehicles must have their designated drive wheels off the ground. Use tow dollies to prevent damage to the transmission.

NOTE: All-wheel or four-wheel drive vehicles require that all wheels be off the ground using a wheel lift and dollies or flatbed equipment.

9. Important additional information

For specific information and safety preparation regarding the High Voltage system, refer to: <https://www.motorcraftservice.com>, select quick guides for the appropriate vehicle emergency response guide.

© Copyright 2021, Ford Motor Company. All rights reserved. This document may be reproduced in its entirety and distributed for emergency responder use only. It may not be excerpted for any purpose.

10. Explanation of pictograms used



Flammable



Explosive



Corrosives



Hazardous to the human health



Environmental hazard



Use water to extinguish the fire



Use ABC powder to extinguish the fire



General warning



Warning, Electricity



Use infrared thermometer / Thermal Infrared camera