

2018 FORD FOCUS RS Owner's Manual Supplement



The information contained in this publication was correct at the time of going to print. In the interest of continuous development, we reserve the right to change specifications, design or equipment at any time without notice or obligation. No part of this publication may be reproduced, transmitted, stored in a retrieval system or translated into any language in any form by any means without our written permission. Errors and omissions excepted.

© Ford Motor Company 2017

All rights reserved.

Part Number: JM5J 19A285 LAA 201706 20170710101557

Table of Contents

Introduction

About This Supplement.....	3
SVT.....	3
Team RS.....	3
Ford Performance.....	4

At a Glance

Unique Features.....	5
----------------------	---

Instrument Cluster

Gauges.....	7
Warning Lamps and Indicators.....	7

Information Displays

General Information.....	8
Information Messages.....	8

Seats

Manual Seats.....	10
-------------------	----

Fuel and Refueling

Fuel Quality.....	11
-------------------	----

Transmission

Manual Transmission.....	12
--------------------------	----

All-Wheel Drive

Using All-Wheel Drive.....	13
----------------------------	----

Brakes

General Information.....	18
--------------------------	----

Stability Control

Using Stability Control.....	19
------------------------------	----

Driving Aids

Drive Control.....	20
--------------------	----

Towing

Towing a Trailer.....	22
-----------------------	----

Driving Hints

Driving Through Water.....	23
Engine Overspeed.....	23
Engine Overboost.....	23

Roadside Emergencies

Transporting the Vehicle.....	24
-------------------------------	----

Fuses

Fuse Specification Chart.....	25
-------------------------------	----

Maintenance

Under Hood Overview.....	27
Engine Oil Dipstick.....	28
Changing the Engine Air Filter.....	28
Drive Belt Routing.....	29

Track Use

Track Use.....	30
----------------	----

Vehicle Care

Cleaning the Exterior.....	31
----------------------------	----

Wheels and Tires

Wheels.....	32
Tires.....	33
Using Summer Tires.....	34
Using Winter Tires.....	34
Tire Pressures.....	35

Capacities and Specifications

Engine Specifications.....	36
Transmission Specifications.....	37
Brake System Specifications.....	38
Steering Specifications.....	39

Table of Contents

Suspension Specifications.....	40
Motorcraft Parts.....	41
Transmission Code Designation.....	41
Capacities and Specifications.....	41

Scheduled Maintenance

General Maintenance Information.....	44
--------------------------------------	----

Introduction

ABOUT THIS SUPPLEMENT

Thank you for choosing Ford Performance. If you have owned or leased a Ford Performance vehicle before, welcome back. If this is your first Ford Performance vehicle, welcome to the family. We are confident that our dedication to performance, quality, craftsmanship and customer service will provide you with many miles of exhilarating, safe and comfortable driving.

We strive to build engaging vehicles that involve the driver in every aspect of the driving experience. Although performance is at the heart of every Ford Performance vehicle, we go further.

Our goal is to deliver a comprehensive, complete vehicle, paying close attention to the smallest details such as the sound of the exhaust, the quality of the interior materials and the functionality and the comfort of the seats, to make sure that you enjoy not only exceptional performance but an outstanding driving environment as well. This philosophy is expressed in this vehicle through a sophisticated powertrain, outstanding chassis dynamics and significant interior and exterior enhancements.

We have created this supplement to help you get to know the unique features of your Ford Performance vehicle. It only contains the instructions for the unique features of the Ford Performance vehicle and is not a substitute for the Owner's Manual. You must read the full instructions in the Owner's Manual. The more that you know about your vehicle, the greater the safety and pleasure you will get from driving it.

Note: *This supplement describes product features and options available throughout the range of available models, sometimes even before they are generally available. It may describe options not fitted to the vehicle you have purchased.*

Note: *Some of the illustrations in this supplement may show features as used in different models, so may appear different to you on your vehicle.*

SVT

The Special Vehicle Team (SVT) was established in 1991 to polish the Ford Oval by creating low-volume, factory-produced vehicles designed for people whose idea of driving is a high-powered, passionate experience - not just a means of getting from A to B.

To support such spirited enthusiasm, we carefully integrated the wide array of talent in the company into a small, cross-functional group of engineers and product planners and located them under one roof with a common mission to create vehicles specifically designed to meet the unique needs and desires of the driving enthusiast.

We produced more than 250,000 SVT vehicles since 1993 model year including the SVT Mustang Cobra and the Cobra R, the SVT F-150 Lightning, the SVT Contour, the SVT Focus, Ford GT, Shelby GT500, GT500KR and the F-150 SVT Raptor.

TEAM RS

Team RS traces its roots back nearly 60 years from the Lotus Cortina and Twin Cam Escorts of the mid-1960s, through the first RS branded Escorts of the 1970s to the founding of Special Vehicle Engineering (SVE) in 1980. Through the 1980s and 90s, SVE delivered a breadth of vehicles from exciting XR and RS branded road going performance cars through homologation specials including the iconic Sierra Cosworth RS500 and RS200. The first ST vehicle appeared in 1996 as the ST24 Mondeo. The first collaboration between our European and

Introduction

North American performance teams appeared in 2002 as the ST170 in Europe and SVT Focus in North America. In 2003, Team RS replaced SVE in Europe when we brought performance car and motorsport personnel together as one team.

FORD PERFORMANCE

Welcome to the Ford Performance family!

Performance and racing are deeply embedded in Ford's DNA, dating back to October 10, 1901 when Henry Ford won his first race against Alexander Winton, America's greatest racer at the time. Henry Ford founded Ford Motor Company 18 months later with capital raised on the back of this remarkable upset victory.

Today, that spirit of passion, innovation and performance lives on through Ford Performance. Established in 2015, the company's performance teams -- Ford Special Vehicle Team (United States), Team RS (Europe), Ford Performance (Australia) and Ford Racing (United States) -- have unified under the mission to create the world's leading performance vehicles, parts, accessories and experiences for enthusiasts. This includes accelerating the development of advanced aerodynamics, lightweighting, electronics, powertrain performance, fuel efficiency and other technologies that can be applied across Ford's product portfolio.

We are proud and passionate about what we do and we look forward to a long and exciting relationship with you. Thank you for choosing Ford Performance!



E211570

At a Glance

UNIQUE FEATURES



E215060

Powertrain

- 2.3L EcoBoost engine.
- High-capacity intercooler.
- High-flow, dual-mode exhaust system.
- Enhanced torque vectoring control.
- All-wheel drive.
- Limited-slip differential.

At a Glance

Chassis

- Brembo front brake calipers.
- Launch control.
- Drive modes.
- Dual-mode dampers.

Exterior

- Radiator grille.
- Underbody shield.
- Diffuser.
- Spoiler.
- Light-weight aluminum or forged aluminum wheels.
- Michelin Pilot Super Sport or Michelin Pilot Sport Cup 2 tires.

Interior

- Performance shift indicator.
- Sony 10-speaker audio system.

Instrument Cluster

GAUGES

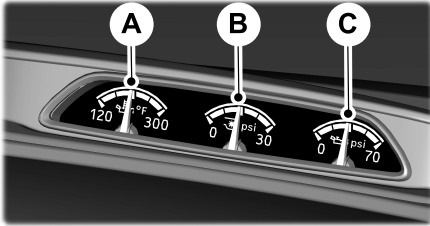

E215771

- A Oil temperature gauge.
- B Turbocharger boost gauge.
- C Oil pressure gauge.

Oil Temperature Gauge

If the needle enters the red section, the engine is overheating. Reduce engine speed as soon as safely possible to allow the engine to cool. If you continue to operate the engine at high engine speeds with the needle in the red section, the engine speed reduces automatically to prevent engine damage.

Turbocharger Boost Gauge

Indicates the added intake pressure provided by the turbocharger.

Oil Pressure Gauge

Oil pressure varies with engine speed. The pressure rises as engine speed rises and drops as engine speed drops.

If the needle enters the red section a warning lamp illuminates and a message appears in the information display. Stop your vehicle as soon as it is safe to do so and switch the engine off. Check the engine oil level.

WARNING LAMPS AND INDICATORS

Performance Shift Indicator



It illuminates when the powertrain reaches the optimum upshift point. It flashes when the engine is close to hitting the engine speed limiter.

Information Displays

GENERAL INFORMATION

Launch Control

The system configures the chassis and powertrain systems to deliver the fastest

possible acceleration when launching from a standing start.

Note: *When you switch the feature on, it is only active once. You must switch the feature on each time it is required.*

To switch the feature on, do the following:

Note: *Your vehicle must be completely stationary.*

Step	Action	
1	Fully press the clutch pedal and shift the gearshift lever to first gear.	
2	Access the following menus using the information display control.	
3	Settings	Expand the menu and then scroll to the following menu item.
4	Driver Assist	Expand the menu and then scroll to the following menu item.
5	Launch Control	Check the box to switch the feature on.
6	Fully press the accelerator pedal. Engine speed automatically limits to 5000 RPM.	
7	Quickly release the clutch pedal when ready to launch.	

Note: *Only use launch control when the front wheels are in the straight ahead position. Make sure there are no objects in front of your vehicle.*

The system does not operate in any of the following conditions:

- The transmission is in reverse (R).
- The engine has not reached normal operating temperature.

The indicator is red or amber depending on the severity of the condition and it remains on until the condition is resolved.

A system-specific symbol with a message indicator may supplement some messages.

INFORMATION MESSAGES

Message Indicator



The message indicator illuminates to supplement some messages.

Information Displays

All-Wheel Drive

Message	Action and Description
AWD OFF	<p>Displays when the system has been automatically disabled to protect itself. This is caused by operating the vehicle with a severely mismatched tire installed, if the system is overheating or if there is an issue with another vehicle system preventing AWD operation. Overheating is most likely to occur if the vehicle is operated in severe conditions, for example track use, or if there is excessive wheel slip, for example your vehicle become stuck in mud.</p> <p>The system resumes normal function and clears this message after:</p> <ul style="list-style-type: none"> • You switch the ignition off and on and drive a short distance with the correct wheels and tires installed. • The system is allowed to cool. • Other vehicle system issues are resolved.
AWD Malfunction Service Required	<p>Displays in conjunction with an amber Information icon if the system is not operating correctly and defaults to front-wheel drive only. If the warning remains on or continues appear, have your vehicle checked as soon as possible.</p>
AWD System Oil Change Due	<p>Displays when the rear drive unit lubrication requires changing. This message may appear if the vehicle is used for extended periods of extreme driving, for example track use.*</p>

*The rear drive unit does not require any normal scheduled maintenance. The system electronically monitors the rear drive unit and notifies you of required service by displaying the message in the information display. The lubricant is more likely to require changing if you use your vehicle for extended periods of extreme driving, for example track use. Do not check or change the lubricant unless the rear drive unit shows signs of leakage or the message displays. If the rear drive unit is submerged in water or to reset the message, have your vehicle checked as soon as possible.

Electronic Stability Control

Message	Action and Description
Electronic Stability Control Off	<p>Displays when you switch the system off.</p>

Seats

MANUAL SEATS

WARNING

 Make sure the seat fully locks into place by rocking it backward and forward.

- C Repeatedly push the lever down to lower the seat.
- C Rotate the handle or move the lever to recline the seatback.



E215587

- A Lift the handle to move the seat backward and forward.
- B Repeatedly lift the lever up to raise the seat.

Fuel and Refueling

FUEL QUALITY

Choosing the Right Fuel

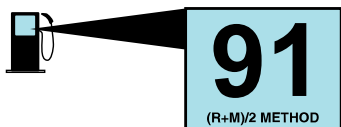

E185193

Use only premium unleaded gasoline with a minimum pump (R+M)/2 octane rating of 91. For optimal performance, use premium unleaded gasoline with an octane rating of 93 or higher.

The use of the correct fuel is an important part of the proper maintenance of your vehicle, and a condition of the vehicle Warranty. For this vehicle, the use of gasoline with an octane level of 91 or higher is required. The use of gasoline with an octane rating lower than 91 will invalidate the vehicle Warranty. It can degrade vehicle performance and lead to severe mechanical damage.

Note: *Use of any fuel other than those recommended can impair the emission control system and cause a loss of vehicle performance.*

Do not use:

- Diesel fuel.
- Fuels containing kerosene or paraffin.
- Fuel containing more than 15% ethanol or E85 fuel.
- Fuels containing methanol.
- Fuels containing metallic-based additives, including manganese-based compounds.

- Fuels containing the octane booster additive, methylcyclopentadienyl manganese tricarbonyl (MMT).
- Leaded fuel (using leaded fuel is prohibited by law).

The use of fuels with metallic compounds such as methylcyclopentadienyl manganese tricarbonyl (commonly known as MMT), which is a manganese-based fuel additive, will impair engine performance and affect the emission control system.

Do not be concerned if the engine sometimes knocks lightly. However, if it knocks heavily under most driving conditions while you are using fuel with the recommended octane rating, contact an authorized dealer to prevent any engine damage.

Transmission

MANUAL TRANSMISSION

Manual transmission vehicles have a starter interlock that prevents cranking the engine unless you fully press the clutch pedal.

Due to the high performance of the powertrain, a certain amount of noise from the transmission is normal.

Note: *During each shift, you must fully press the clutch pedal to the floor and fully release the accelerator. Failure to follow this may cause increased shift efforts, prematurely wear transmission components, or cause gear clash or damage to the transmission.*

Note: *Do not attempt to shift when the wheels do not have traction. Resulting component damage may not be covered by the vehicle Warranty.*

Note: *Do not drive with your foot resting on the clutch pedal or use the clutch pedal to hold your vehicle at a standstill while waiting on a hill. Resulting component damage may not be covered by the vehicle Warranty.*

Recommended Shift Speeds

We recommend you shift gears according to the following guide to help achieve the best fuel economy for your vehicle.

Gear Shifts	Vehicle Speed mph (km/h)
1-2	15 (24)
2-3	25 (40)
3-4	40 (65)
4-5	45 (72)
5-6	50 (80)

All-Wheel Drive

USING ALL-WHEEL DRIVE

Your vehicle has All-Wheel Drive with Dynamic Torque Vectoring. This feature uses all four wheels to power the vehicle and independently controls the torque to each rear wheel. The system also has the ability to over speed the outside rear wheel while cornering. This increases traction and handling performance giving your vehicle road holding capabilities that are superior to conventional two-wheel drive and four-wheel drive vehicles. The system is active all the time and requires no input from the driver. The system has different Drive Mode calibration settings that optimize all-wheel drive performance for various conditions. See **Drive Control** (page 20).

Your vehicle is not intended for off-road use in the same way as an all-terrain vehicle. The all-wheel drive feature gives your vehicle some limited off-road capabilities where driving surfaces are relatively level, obstruction-free and similar to normal on-road driving conditions. Operating your vehicle under other than those conditions could subject the vehicle to excessive stress which can result in damage not covered by the vehicle Warranty.

The rear drive unit does not require any normal scheduled maintenance. The system is electronically monitored and any required service messages appear in the information display. The rear drive unit lubricants may require changing if you use your vehicle for extended periods of high speed driving, for example track use. You are not required to check or change the rear drive unit lubricant unless there are signs of leakage or a message appears in the information display indicating that the unit requires service.

Using Mismatched Tires or Wheels

WARNINGS



Only use replacement tires and wheels that are of the same size, load index, speed rating and type as those originally fitted to your vehicle.



Using a tire or wheel that is not recommended can affect the safety and performance of your vehicle and could result in a loss of vehicle control, vehicle rollover, personal injury or death.

The recommended tire and wheel size can be found on either the Safety Compliance Certification Label or the tire information label on the left-hand B-pillar or left-hand front door. If this information is not located as stated contact an authorized dealer as soon as possible.

Note: *Using a tire or wheel that is not recommended could cause steering, suspension, axle, power transfer unit or rear drive unit failure. Incorrect tire or wheel use can cause damage not covered by the vehicle Warranty.*

Your vehicle does not have a spare tire. We do not recommend using a mismatched tire or spare wheel. However, in an emergency, the system can tolerate a mismatched tire or spare wheel of a different size to the original for a short journey. The system may automatically enter front-wheel drive only mode to protect driveline components. An all-wheel drive off warning message may appear in the information display if you install a mismatched tire or spare wheel. See **Information Messages** (page 8). The message turns off after you reinstall the correct wheel and tire and you switch the ignition off and on. We recommend that you reinstall the repaired or replaced wheel and tire as soon as possible.

All-Wheel Drive

Major mismatched tire or wheel sizes between the front and rear axles, for example 18 inch low profile tires on the front axle and 20 inch high profile tires on the rear axle could cause the system to default to front-wheel drive only mode. Damage to the system can occur that may not be covered by the vehicle Warranty.

The system can tolerate any combination of new and worn tires of the same original tire size. For example, using three worn tires and one new tire.

Driving in Special Conditions

Your vehicle is capable of being driven on sand, snow, mud or a loose surface. However the operating characteristics are different from conventional off-road vehicles.

Note: *Under severe operating conditions, the air conditioning may turn on and off to protect the engine from overheating.*

Basic Operating Principles

WARNING



Be extremely careful when driving on road surfaces that are made slippery by loose sand, water, gravel, snow or ice. Failure to adhere to this warning could result in the loss of vehicle control, serious personal injury or death.

Emergency Maneuvers

If your vehicle goes off the edge of the road, slow down but avoid severe brake application, only ease the vehicle back onto the road after reducing your speed. Do not turn the steering wheel too sharply while returning to the road surface. It may be safer to stay on the apron or shoulder of the road and slow down gradually before returning to the road surface. You may lose control if you do not slow down or if you turn the steering wheel too

sharply. It may be better to strike small objects, for example highway reflectors, with minor damage to your vehicle rather than attempt a sudden return to the road surface, which could cause your vehicle to slide sideways out of control or rollover. Remember, your safety and the safety of others should be your primary concern.

In an unavoidable emergency situation where a sudden sharp turn must be made, remember to avoid over-driving your vehicle. Only turn the steering wheel as rapidly and as far as required. Excessive steering results in less vehicle control, not more. Additionally, smooth variations of the accelerator or brake pedal pressure should be utilized if changes in vehicle speed are required. Avoid abrupt steering, acceleration or braking which could result in an increased risk of loss of vehicle control, rollover and personal injury. Use all available road surface to return the vehicle to a safe direction of travel.

If your vehicle goes from one surface type to another, for example from concrete to gravel, there will be a change in the way your vehicle responds to steering, acceleration or braking.

If Your Vehicle Gets Stuck

WARNING



Do not spin the wheels at over 35 mph (56 km/h). The tires may fail and injure a passenger or bystander.

If your vehicle gets stuck in mud or snow it may be rocked out by shifting between forward and reverse gears, stopping between shifts, in a steady pattern. Press lightly on the accelerator in each gear.

If your vehicle is stuck in mud or snow, switching traction control off may be beneficial while attempting to rock your vehicle.

All-Wheel Drive

Note: Do not rock the vehicle if the engine is not at normal operating temperature or damage to the transmission may occur.

Note: Do not rock the vehicle for more than a few minutes or damage to the transmission and tires may occur or the engine may overheat.

Sand

Most of the time traction control improves tire traction by managing wheel slip through brake, engine, and all-wheel drive calibrations. However, during low speed driving, disabling traction control in deep sand can help keep the wheels moving to maintain vehicle momentum.

When driving over sand, try to keep all four wheels on the most solid area of the trail. Do not reduce tire pressures, shift to a lower gear and drive steadily through the terrain. Apply the accelerator slowly and avoid spinning the wheels.

When driving at slow speeds in sand under high outside temperatures, use a low gear when possible. Using a low gear maximizes engine and transmission cooling capability.

Avoid excessive speed because vehicle momentum can work against you and cause the vehicle to become stuck to the point that assistance may be required from another vehicle. Remember, you may be able to back out the way you came if you proceed with caution.

Note: You may be able to reverse out the way you came if you proceed with caution.

Do not drive your vehicle in deep sand for an extended period of time. This could cause the system to overheat and default to front-wheel drive only mode. If this occurs a message appears in the information display. To resume normal all-wheel drive function as soon as possible, stop the vehicle in a safe location and switch the engine off for at least 10 minutes. After the all-wheel drive system

has adequately cooled and the engine has been restarted, the message turns off and normal all-wheel drive function returns. If you do not switch the engine off, the message only turns off, when the system adequately cools and the normal all-wheel drive function returns.

Note: Under severe operating conditions, the air conditioning may turn on and off to protect the engine from overheating.

Mud and Water

If you must drive through water, drive slowly. Traction or brake capability may be limited. See **Driving Through Water** (page 23).

Once through water, always try the brakes. Wet brakes do not stop the vehicle as effectively as dry brakes. Drying can be improved by moving your vehicle slowly while applying light pressure on the brake pedal.

Be cautious of sudden changes in vehicle speed or direction when you are driving in mud. Even all-wheel drive vehicles can lose traction in slick mud. Apply the accelerator slowly and avoid spinning the wheels.

After driving through mud, clean off excessive mud that has become stuck to rotating drive shafts, wheels and tires. Excessive mud stuck on these components may result in an imbalance that could cause damage not covered by the vehicle Warranty.

If the transmission, power transfer unit or rear drive unit is submerged in water have your vehicle checked as soon as possible.

All-Wheel Drive

Hilly or Sloping Terrain

WARNING



Avoid driving across or turning on steep hilly or sloping terrain. Your vehicle may lose traction and slip sideways increasing the risk of rolling over. When driving on steep hilly or sloping terrain, determine your route beforehand. Do not drive over the crest of a hill without assessing what conditions are on the other side. Do not reverse over a hill without the aid of an observer.

Although natural obstacles may make it necessary to travel diagonally up or down a hill or steep incline, you should always try to drive straight up or straight down.

Apply just enough power to the wheels to climb the hill. Too much power will cause the tires to slip, spin or lose traction, resulting in loss of vehicle control.

When climbing a steep hill or slope, start in a lower gear rather than downshifting to a lower gear from a higher gear once the ascent has started. This reduces strain on the engine and the possibility of stalling.

Note: *If your vehicle stalls, do not try to turn around as your vehicle may lose traction and slip sideways increasing the risk of rolling over. It is better to reverse down to a safe location.*

When descending a steep hill or slope, start in a lower gear rather than downshifting to a lower gear from a higher gear once the descent has started. Do not descend a steep hill or slope in neutral. Avoid excessive brake application as this causes the brakes to overheat. When descending a steep hill or slope, avoid sudden hard braking as you could lose control. The front wheels must rotate in order to steer your vehicle. Your vehicle has anti-lock brakes, therefore apply the brakes steadily. Do not pump the brake pedal.

Snow and Ice

WARNING



If you are driving in slippery conditions that require tire chains or cables, then it is critical that you drive cautiously. Keep speeds down, allow for longer stopping distances and avoid aggressive steering to reduce the chances of a loss of vehicle control, personal injury or death.

Note: *The original equipment tires on your vehicle are designed to optimize the performance of your vehicle in dry or wet summer road conditions. We recommend using a dedicated set of winter tires in snow and ice conditions. Do not mix summer performance tires with winter tires on your vehicle. See **Using Winter Tires** (page 34).*

All-wheel drive vehicles have advantages over two-wheel drive vehicles in snow and ice but can skid like any other vehicle.

All-Wheel Drive

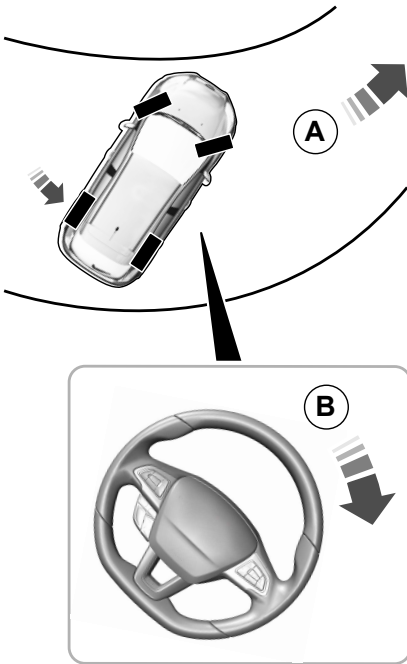

Avoid sudden braking while driving on snow or icy roads. Although your vehicle may accelerate better than a two-wheel drive vehicle on snow and ice, stopping distances are not reduced. Make sure you allow sufficient distance for stopping. Drive slower than usual and consider using a lower gear. Your vehicle has anti-lock brakes, therefore apply the brakes steadily. Do not pump the brake pedal.

E223901

- A Direction of travel.
- B Steering wheel rotation.

If the rear of your vehicle starts to oversteer and slide on snow or icy roads, turn the steering wheel in the direction of travel as shown above to help regain control.

Note: *Excessive tire slippage can cause driveline damage.*

Avoid sudden applications of power and quick changes of direction while driving on snow or icy roads. Apply the accelerator slowly and steadily when starting from a full stop.

Brakes

GENERAL INFORMATION

Your vehicle has a braking system designed for high performance driving and superior brake fade resistance. You may notice occasional brake noise and elevated levels of brake dust. This is normal and does not affect system performance.

Stability Control

USING STABILITY CONTROL

WARNINGS



Do not switch off stability control or use Sport, Track or Drift mode when using a temporary spare wheel or after inflating a tire using the temporary mobility kit.



If you switch stability control off, active city stop also turns off.

The system automatically turns on each time you switch the ignition on.



E194298

Press the button on the center console to switch sport mode on or to switch the system off.

Switching Sport Mode On

Press and release the switch. You will see a message in conjunction with an illuminated icon in the display. Press and release the switch again to return the system to normal mode.

When you switch sport mode on, traction control is switched off while stability control intervention is reduced.

Note: You may not be able to switch Sport mode on when using a programmed MyKey. See **MyKey** for more information.

Switching the System Off

Press and hold the switch for approximately five seconds. You will see a message in conjunction with an illuminated icon in the display. Press and release the switch again to return the system to normal mode.

Note: When using a programmed MyKey you cannot switch this off.

Driving Aids

DRIVE CONTROL

WARNING



Do not use Sport, Track or Drift mode when using a temporary spare wheel or after inflating a tire using the temporary mobility kit.

Your vehicle has various drive modes that can deliver driving experiences through a suite of sophisticated electronic systems. Each mode has preset vehicle settings to optimize steering, all-wheel drive, torque vectoring, powertrain response, suspension and electronic stability control.

Selectable Drive Modes

DRIVE
MODE

Press the button.

The available modes appear in the information display. Repeatedly press the button to scroll through the available modes. When your desired mode appears in the information display, wait for four seconds while the system sets the selected mode or press the **OK** button on the steering wheel.

Note: You may not be able to choose one of the selectable drive modes for a short time after starting your vehicle in cold ambient temperatures.

Selectable Drive Modes

Normal



The system defaults to normal mode when you start the vehicle. Vehicle settings tuned for street driving.

Electronic stability control and traction control systems fully enabled.

Note: When using a programmed MyKey you cannot switch any other mode on.

Sport



Vehicle settings tuned for performance street driving.

Electronic stability control and traction control systems fully enabled.

Note: When using a programmed MyKey you cannot switch this on.

Track



This mode is for track use only. Vehicle settings tuned for aggressive driving.

The system reduces brake system intervention from the stability control system and optimizes the road-holding ability of your vehicle. Electronic stability control is set to reduced mode while the traction control system is disabled apart from the electronic limited slip differential function. Engine interventions from the stability control and traction control systems are also disabled.

Note: When using a programmed MyKey you cannot switch this on.

Drift



This mode is for track use only. Vehicle settings tuned for spirited and aggressive driving.

The system reduces brake system intervention from the stability control system and increases torque transfer to the rear axle to allow controlled oversteer drifts.

Electronic stability control is set to reduced mode while the traction control system is disabled apart from the electronic limited slip differential function. Engine interventions from the stability control and traction control systems are also disabled.

Driving Aids

The electronic stability control or all-wheel drive system may automatically turn off during extreme drifting maneuvers. If a system turns off, the electronic stability control warning lamp illuminates or a corresponding all-wheel drive message appears in the information display. Continue to drive and when normal driving resumes, the systems automatically turn on within a short period. If the electronic stability control warning lamp remains illuminated or a warning message remains in the information display, have your vehicle checked as soon as possible.

Note: *When using a programmed MyKey you cannot switch this on.*

Suspension Damping

Selectable Suspension Damping

Normal

The system defaults to normal mode when you start the vehicle. Vehicle suspension damping tuned for street driving.

Sport

Vehicle suspension damping tuned for performance driving on flat roads or for track use. Sport mode gives firmer suspension damping characteristics.

To select normal or sport mode, do the following:



E219514

1. Press and hold the button for a short period of time. The current setting appears in the information display. Release the button again to change the setting.

Enhanced Torque Vectoring Control

The system consists of two elements:

- Torque vectoring control. Automatically applies brake torque on the inner wheel in a curve to increase traction and decrease understeer.
- Cornering understeer control. Automatically controls the traction response of your vehicle when you accelerate on high and low friction surfaces.

Unlike electronic stability control, enhanced torque vectoring control does not slow the vehicle. The system limits excessive wheel slip giving greater cornering ability.

Note: *The system does not disable enhanced torque vectoring control if you switch the stability control system or traction control system off.*

In addition to enhanced torque vectoring control, your vehicle also has all-wheel drive with dynamic torque vectoring.

This feature further improves the road-holding and traction abilities of your vehicle. See **All-Wheel Drive** (page 13).

Towing

TOWING A TRAILER

WARNING



Your vehicle is not approved for trailer towing. Never tow a trailer with your vehicle.

Driving Hints

DRIVING THROUGH WATER

Your vehicle has aerodynamic devices attached to the underbody designed to help control airflow for superior performance. Therefore, you must be especially careful to avoid driving through deep or standing water.

ENGINE OVERSPEED

WARNING



Do not operate the engine at high engine speeds while the vehicle is stationary. This can cause damage not covered by the vehicle Warranty and can result in serious injury.

Your vehicle has an engine speed limiter that helps increase engine performance. A narrow red line on the tachometer face indicates the standard maximum engine speed. The red line thickens where the engine speed enters the overspeed limiter.

The system allows a maximum of three seconds of engine overspeed. After this, the engine speed limiter reduces engine speed and holds it at a predetermined limit. Once the engine speed drops below the predetermined limit, the system resets and permits a further three seconds of engine overspeed.

Note: *Do not run the engine at high engine speeds until it reaches the normal operating temperature.*

ENGINE OVERBOOST

Your vehicle has an engine overboost feature to allow additional torque delivery. The overboost feature controls a variety of engine parameters to deliver additional torque. This feature widens the engine speed range of the peak torque curve, giving maximum performance while passing another vehicle or launching from a standing start.

The system allows a maximum of 20 seconds of engine overboost. After this the system reduces turbo charger boost and maximizes it at a predetermined limit. Once the turbo charger boost drops below the predetermined limit the system resets and a further 20 seconds of engine overboost is permitted.

Note: *You do not need to take any action as the system allows overboost when you demand it.*

Roadside Emergencies

TRANSPORTING THE VEHICLE

If your vehicle has to be towed, we recommend that you contact a professional towing service. If you are a member of a roadside assistance program, we recommend that you contact your roadside assistance service provider.

We recommend the use of flatbed equipment to transport your vehicle.

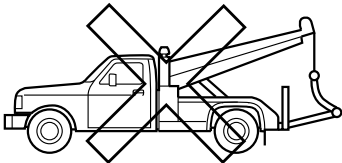
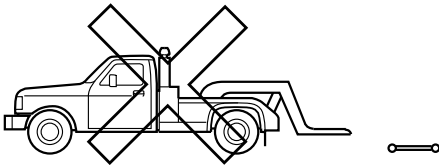
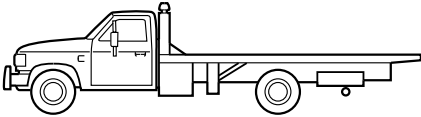

E203788

Vehicle damage may occur if towed incorrectly or by any other method.

- Do not tow your vehicle using wheel lift equipment.
- Do not tow your vehicle using a slingbelt.

Note: *Incorrect towing methods can cause damage not covered by the vehicle Warranty.*

Fuses

FUSE SPECIFICATION CHART

Engine Compartment Fuse Box

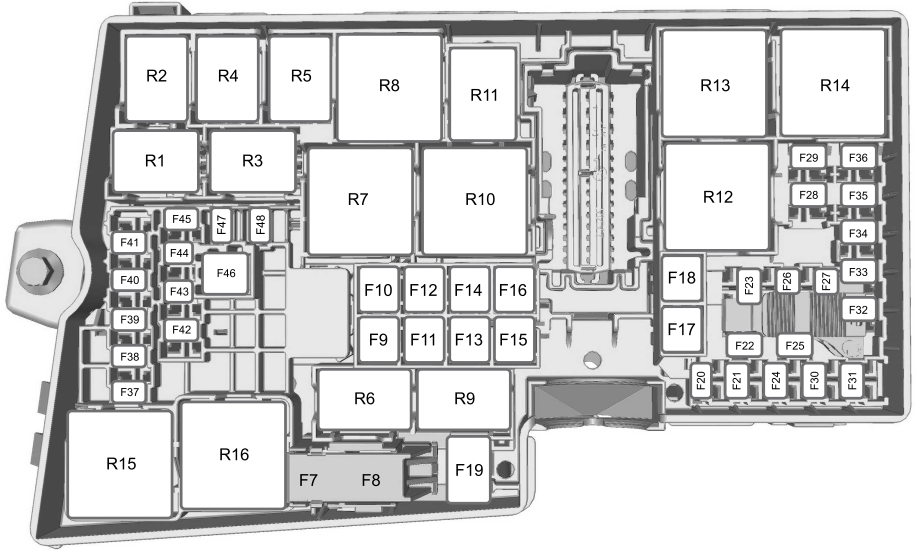

E129925

Fuse Location	Fuse Rating	Protected Component
F17	30 A	Rear drive unit control.
F30	20 A	Fuel pump electronic module 2 feed.
F36	7.5 A	Exhaust valve.

Relay Number	Protected Component
R1	Fuel pump electronic module 2 feed.
R3	Cooling fan control 4.
R5	Cooling fan control 5.

Fuses

Luggage Compartment Fuse Box

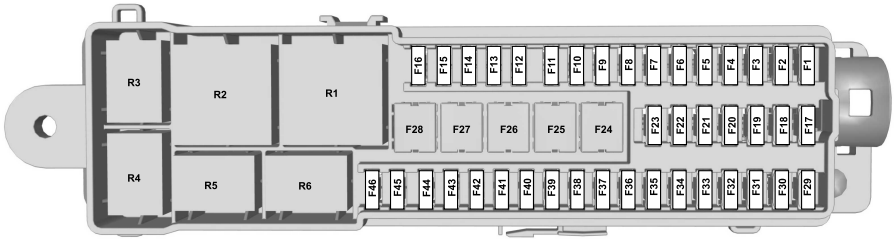

E129927

Fuse Location	Fuse Rating	Protected Component
F21	15 A	Fuel control relay. Damper control relay.
F22	10 A	Not used (spare).

Relay Number	Protected Component
R4	Fuel control module. Damper control module.

Maintenance

UNDER HOOD OVERVIEW

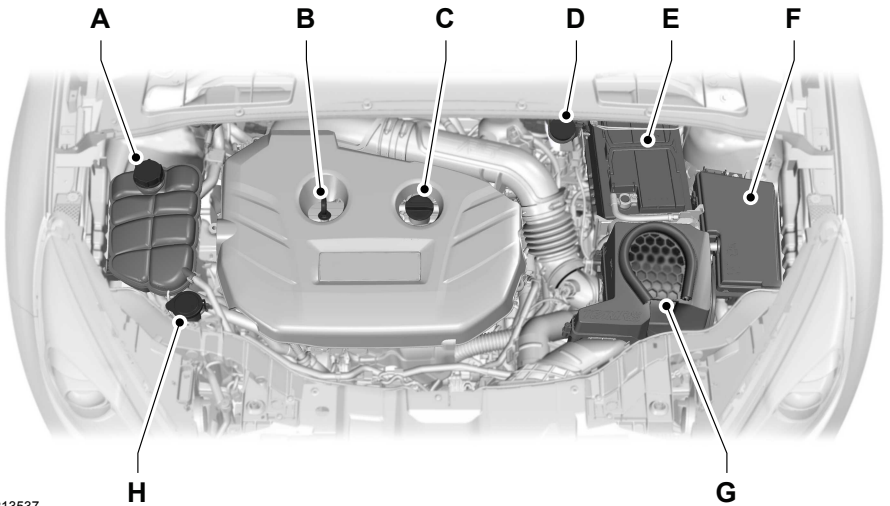

E213537

- A Engine coolant reservoir.
- B Engine oil dipstick. See **Engine Oil Dipstick** (page 28).
- C Engine oil filler cap.
- D Brake fluid reservoir.
- E Battery.
- F Engine compartment fuse box. See **Fuses** (page 25).
- G Air filter. See **Changing the Engine Air Filter** (page 28).
- H Washer system fluid reservoir.

Maintenance

ENGINE OIL DIPSTICK

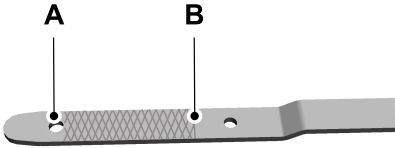

E169062

- A Minimum.
- B Maximum.

CHANGING THE ENGINE AIR FILTER

WARNING



To reduce the risk of vehicle damage and personal burn injuries, do not start your engine with the air cleaner removed and do not remove it while the engine is running.

Change the air filter element at the correct interval. Only use the specified replacement air filter. Incorrect component use can cause damage not covered by the vehicle Warranty.

When changing the engine air filter, do not allow debris or foreign material to enter the air induction system. The engine and turbocharger are susceptible to damage from even small particles.

To replace the air filter element do the following:

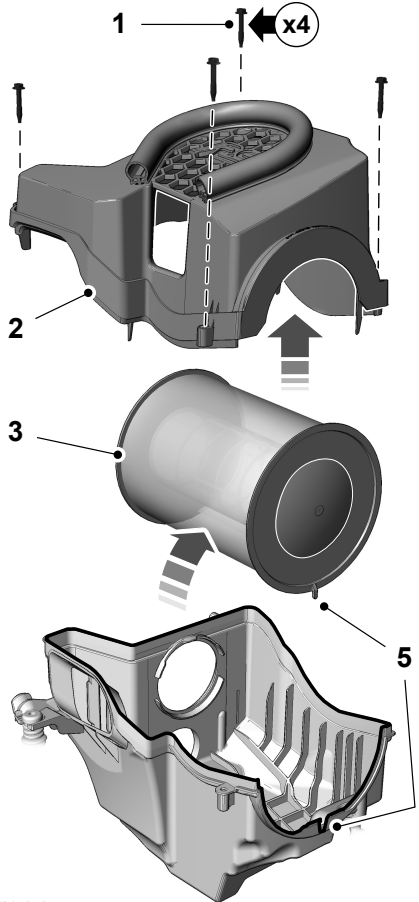

E215050

1. Remove the screws that secure the air filter housing cover.
2. Remove the air filter housing cover.
3. Remove the air filter element from the air filter housing.

Maintenance

4. Wipe any dirt or debris from the air filter housing and cover to make sure no dirt gets in the engine and that you have a good seal.

5. Install a new air filter element.

Note: Make sure you align the locating tab on the air filter element with the fork in the air filter housing.

6. Install the air filter housing cover.

7. Install the screws to secure the air filter housing cover to the air filter housing.

DRIVE BELT ROUTING

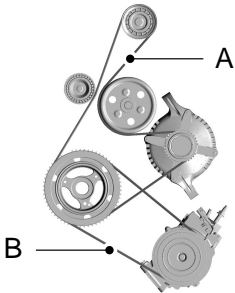

E161383

A Drives the water pump and alternator and has two idler pulleys.

B Drives the air conditioning compressor.

Track Use

We recommend that you only operate your vehicle at high speeds at locations designed to do so safely. Your vehicle has electronic controls that may reduce power or limit engine speed to help reduce powertrain temperatures if required.

Note: *When using your vehicle on a track, have the vehicle serviced more frequently. This recommendation may not necessarily protect your vehicle or engine from damage in competition conditions. Increased wear and noise to certain parts of your vehicle may also occur, for example brakes and tires. The vehicle Warranty may not cover mechanical failure or damage caused to your vehicle as a result of track use.*

Steering Assistance



Steering assistance reduces and requires more steering effort when you select sport or track from the drive modes menu. See **Drive Control** (page 20).

Prolonged track driving can result in high steering gear temperatures. If the steering gear overheats, you will notice a further increase in steering effort being required.

High steering gear temperatures can be reduced by doing any of the following:

- Reducing vehicle speed.
- Reducing steering input.

Normal track mode steering assistance returns when the system cools down.

Note: *Steering gear cooling time can be reduced if you leave the ignition switched on while taking a pit stop.*

Before Track Use

Before operating your vehicle on a track, check the following:

- Tire pressures. See **Tire Pressures** (page 35). Do not exceed a cold tire pressure of 50 psi (3.4 bar) for track use.
- Wheels and tires for wear and damage.
- Engine coolant, engine oil and brake fluid levels.

Do not operate your vehicle on a track while:

- Carrying more than two people including the driver.
- Carrying cargo in the luggage compartment.
- Carrying cargo or loose objects inside your vehicle.

After Track Use

After track use, leave the engine running for a short time to allow it to reach the normal operating temperature. If conditions allow, complete a cool down lap prior to taking a pit stop. Failure to allow the engine to sufficiently cool may result in a high coolant temperature warning message appearing in the information display.

You must replace the rear drive unit fluid after 500 mi (800 km) of track use, or if the following message appears in the information display, whichever occurs first.

AWD System Oil Change Due

See **All-Wheel Drive** (page 13).

CLEANING THE EXTERIOR

Your vehicle has heat exchangers integrated with the front fascia designed to maximize performance.

Do not apply a high-pressure washer directly to the heat exchangers as damage to the cooling fins could occur.

Cleaning Vehicle Wrap (if Equipped)

Do not wash your vehicle for the first six weeks after the application of the wrap.

To prevent water from getting under the wrap, contact an authorized dealer to repair any damage caused by stone chips as soon as possible.

Do not use a hot wax treatment if you use a car wash facility.

Note: *Car wash brushes could damage the wrap.*

Note: *Bubbles could appear under the wrap for a few weeks after the first application and also during high outside temperatures. These normally disappear after a short period of time. If these do not, please contact an authorized dealer.*

Precautions for High-Pressure Wash

- Do not use water pressure higher than 1,200 psi (80 bar).
- Do not use water hotter than 140°F (60°C).
- Keep the nozzle at a minimum distance of 12 in (30 cm) and minimum angle of 30° to your vehicle's surface.

Wheels and Tires

WHEELS

Your vehicle has unique wheels. They can be more susceptible to damage from poor road conditions due to their diameter, width and the use of low profile tires.

If the wheels encounter a harsh impact, inspect the inside and outside diameters for damage.

Inspect the wheels for damage on a regular basis. If you damage a wheel, have it checked as soon as possible.

To avoid damaging the wheels:

- Maintain correct tire pressures. See **Tire Pressures** (page 35).
- When installing wheels, always use a torque wrench and tighten the lug nuts to the correct specification.
- Exercise caution when using automated car washes. Hand washing or using touchless car washes without mechanical tracks is the best way to avoid potential damage.
- Do not use snow chains on the original equipment wheels and tires of your vehicle.
- Only use snow chains with the alternative winter wheels and tires, or damage may be caused which will not be covered by the vehicle Warranty.

Wheel Specification

Original equipment.*	19 in. x 8.0 in. 50 mm offset aluminum wheels.
Alternative winter use wheel.**	18 in. x 7.5 in. 50 mm offset aluminum wheels.

* See **Tires** (page 33). ** See **Using Winter Tires** (page 34).

Note: *Alternative winter use wheels are not supplied with your vehicle.*

Wheels and Tires

TIRES

The tires on your vehicle are designed to optimize its performance. They are not optimized for off-road or winter performance. The ride, noise and wear characteristics are different to non-performance tires. Your vehicle has low profile tires. They can be more susceptible to damage from poor road conditions due to their diameter and width.

To make sure the tires perform as intended, it is important to correctly maintain them.

To correctly maintain the tires, do the following:

- Maintain correct tire pressures. See **Tire Pressures** (page 35).
- Do not overload your vehicle. Maximum vehicle and axle weights are listed on the tire information label.
- Take extra caution when operating your vehicle near its maximum load, including using the correct tire pressures and reducing speeds.

- Take extra caution when operating on rough roads to avoid impacts that could cause tire damage.
- Inspect the tires for damage on a regular basis. If a tire is damaged, replace it as soon as possible.
- Correct suspension alignment is critical for maximum performance and optimal tire wear. If you notice uneven tire wear, have the suspension alignment checked as soon as possible.
- When replacing tires they must be of the same size, speed and load rating as the original tires. We recommend that you replace tires as a set of four and do not mix tire brands or models.

Note: Do not use snow chains on the original equipment wheels and tires of your vehicle.

Note: Only use snow chains with the alternative winter wheels and tires, or damage may be caused which will not be covered by the vehicle Warranty. See **Using Winter Tires** (page 34).

Tire Specification

Size.	235/35R19
Speed rating.	Y
Load rating.	91

Wheels and Tires

USING SUMMER TIRES

The original equipment tires on your vehicle are designed to optimize its performance in dry or wet summer road conditions. The rubber compounds used in these tires lose flexibility and may develop surface cracks in the tread area at temperatures below 19°F (-7°C).

We do not recommend using the original equipment tires when temperatures drop below 45°F (7°C) or in snow and ice conditions.

Storing Summer Tires

Note: Always store your tires indoors at temperatures above 19°F (-7°C).

If the tires have been subjected to 19°F (-7°C) or less, warm the tires for at least 24 hours in a heated space to at least 41°F (5°C):

- Before installing them on a vehicle.
- Before moving a vehicle.
- Before checking tire inflation.

Note: Do not place tires near heaters or heating devices used to warm the room where the tires are stored.

Note: Do not apply heat or blow heated air directly onto the tires.

Winter Tire Specification

Original equipment size.	235/35R19
Alternative winter use size.	225/40R18*
Speed rating.	V
Load rating.	92

*Required tire size for snow chain use to avoid tire, wheel or vehicle damage. See **Wheels** (page 32).

Note: Always inspect the tires after storage periods and before use.

USING WINTER TIRES

The original equipment tires on your vehicle are designed to optimize its performance in dry or wet summer road conditions. They are not optimized for off-road or winter performance and you must not use them with snow chains. The use of any type of snow chain with the original equipment wheels and tires of your vehicle may cause damage not covered by the vehicle Warranty. We do not recommend using the original equipment tires when temperatures drop below 45°F (7°C) or in snow and ice conditions.

We recommend that you use winter or all-season tires when temperatures drop below 45°F (7°C) or in snow and ice conditions.

When using winter tires:

- Do not operate your vehicle above posted speed limits or perform high speed maneuvers.
- If you fit winter tires with a speed rating less than the original equipment tires, do not exceed the maximum speed rating for the tire.

Wheels and Tires

TIRE PRESSURES

Check all tire pressures when they are cold, at least once every two weeks. Check them after the vehicle has been parked for at least three hours. Tire pressure can diminish over time and fluctuate with temperature. Do not reduce the tire pressure of warm tires.

The recommended tire inflation pressures are on the tire information label on the driver side B-pillar.

Note: *Do not exceed a cold tire pressure of 50 psi (3.4 bar) for track use.*

Capacities and Specifications

ENGINE SPECIFICATIONS

Dimension Description	Specification
Engine capacity.	138.0 in ³ (2,261.4 cm ³)
Engine bore.	3.4 in (87.5 mm)
Engine stroke.	3.7 in (94 mm)
Compression ratio.	9.4:1
Ignition firing order.	1-3-4-2
Ignition system.	Coil on spark plug
Spark plug gap.	0.030 in (0.75 mm)
Maximum net power kW/RPM.	257.4/6000*
Maximum net power PS/RPM.	350/6000*
Maximum net power hp/RPM.	345/6000*
Maximum net torque Nm/RPM.	440/2000-4500
Maximum net torque lb.ft/RPM.	325/2000-4500
Maximum continuous engine RPM.	6500
Maximum intermittent engine RPM.	6800
Camshaft drive.	Chain

*We derive engine performance figures according to Regulation (EC) 715/2007 and ECE R85.

Capacities and Specifications

TRANSMISSION SPECIFICATIONS

Transmission and final drive ratios

6-Speed Manual Transmission - MMT6		
Gear	Gear Ratio	Final Drive Ratio
1st gear.	3.23	4.063
2nd gear.	1.95	4.063
3rd gear.	1.32	4.063
4th gear.	1.03	4.063
5th gear.	1.13	2.955
6th gear.	0.94	2.955
Reverse gear.	4.60	2.955

Capacities and Specifications

BRAKE SYSTEM SPECIFICATIONS

Dimension Description	in (mm)
Brake pedal free travel.	0.4–1.2 (10–30)
Front brake disc minimum thickness.	0.9 (23)
Rear brake disc minimum thickness.	0.4 (9)

Capacities and Specifications

STEERING SPECIFICATIONS

Wheel Alignment

Dimension Description	Specification
Front wheel - Total Toe.	0.20° ±0.20°
Rear wheel - Total Toe.	0.30° ±0.20°

Turning Circle

Dimension Description	Specification
Minimum turning circle.	39.4 ft (12 m)

Capacities and Specifications

SUSPENSION SPECIFICATIONS

Dimension Description	Specification
Front camber.	-1.51° ($\pm 1.25^\circ$)
Front caster.	4.79° ($\pm 1^\circ$)
Rear camber.	-0.97° ($\pm 1.25^\circ$)
Front suspension.	Macpherson strut.
Rear suspension.	Multilink.
Front spring rate.	40 N/mm
Rear spring rate.	44 N/mm
Front stabilizer bar.	24.2 mm
Rear stabilizer bar.	20 mm

Capacities and Specifications

MOTORCRAFT PARTS

Component	Part Number
Air filter.	FA-1908
Oil filter.*	FL-910-S
Battery.	BAGM-48H6-760
Spark plugs.**	SP-527
Cabin air filter.	FP-70
Driver side windshield wiper blade.	WW-2802
Passenger side windshield wiper blade.	WW-2803
Rear window wiper blade.	WW-1295

*If you are unable to find a Motorcraft oil filter that meets the specification defined within FL-910-S, it is acceptable to use an oil filter that is defined by the specification SAE/USCAR-36.

**We recommend that you contact an authorized dealer for spark plug replacement.

We recommend that you demand the use of genuine Ford and Motorcraft parts whenever your vehicle requires scheduled maintenance or repair. Genuine Ford and Motorcraft parts meet or exceed these specifications. Incorrect component use can cause damage not covered by the vehicle Warranty.

TRANSMISSION CODE DESIGNATION

Transmission	Code
Getrag-Ford Transmission. 6-Speed Manual Transmission - MMT6	V

CAPACITIES AND SPECIFICATIONS

WARNING



The air conditioning refrigerant system contains refrigerant under high pressure. Only qualified personnel should service the air conditioning refrigerant system. Opening the air conditioning refrigerant system can cause personal injury.

Capacities and Specifications

Item	Quantity
Engine oil fill capacity including the oil filter.	5.7 qt (5.4 L)
Engine oil fill capacity excluding the oil filter.	5.4 qt (5.1 L)
Engine coolant fill capacity.	9.7 qt (9.2 L)
Brake fluid fill capacity.	Between MIN and MAX on brake fluid reservoir.
Manual transmission fluid fill capacity.	2.0 qt (1.9 L)
Power transfer unit fill capacity.	0.8 qt (0.75 L)
Rear drive unit fill capacity.	30.1 fl oz (890 ml)
Washer system fill capacity.	1.2 gal (4.5 L)
Fuel tank fill capacity.	13.7 gal (52 L)
Air conditioning refrigerant fill capacity.	22.05 oz (0.625 kg)
Air conditioning refrigerant compressor oil fill capacity.	4.40 fl oz (130 ml)

Adding Engine Oil

Quantity
0.9 qt (0.85 L)

The quantity of engine oil required to raise the indicated level on the dipstick from minimum to maximum.

Materials

Name	Specification
Motorcraft® SAE 5W-50 Full Synthetic Motor Oil (U.S.) Huile moteur synthétique SAE 5W-50 Motorcraft® (Canada) XO-5W50-QGT (U.S. & Canada)	WSS-M2C931-C
Motorcraft® Orange Prediluted Antifreeze/Coolant (U.S.) Antigel/liquide de refroidissement prédilué orange Motorcraft® (Canada) VC-3DIL-B (U.S.) CVC-3DIL-B (Canada)	WSS-M97B44-D2
Motorcraft® DOT 4 LV High Performance Motor Vehicle Brake Fluid (U.S.) Liquide de frein automobile haute performance DOT 4 LV Motorcraft® (Canada)	WSS-M6C65-A2

Specifications

Only use fluid that meets Ford specifications.

Capacities and Specifications

Name	Specification
PM-20 (U.S. & Canada)	
Motorcraft® Dual Clutch Transmission Fluid (U.S.) Huile pour boîtes embrayage double Motorcraft® (Canada) XT-11-QDC (U.S. & Canada)	WSS-M2C200-D2
Motorcraft® SAE 75W-140 Synthetic Rear Axle Lubricant (U.S.) Lubrifiant synthétique pour pont arrière SAE 75W-140 Motorcraft® (Canada) XY-75W140-QL (U.S.) CXY-75W140-1L (Canada)	WSL-M2C192-A
Motorcraft® SAE 75W-85 Premium Synthetic Hypoid Gear Lubricant (U.S.) Huile synthétique de haute qualité pour engrenages hypoides SAE 75W-85 Motorcraft® (Canada) XY-75W85-QL (U.S. & Canada)	WSS-M2C942-A
Motorcraft® Premium Windshield Wash Concentrate with Bitterant (U.S.) Liquide lave-glace de haute qualité Motorcraft® (Canada) ZC-32-B2 (U.S.) CXC-37-A/B/D/F (Canada)	WSS-M14P19-A
R-1234yf Refrigerant (U.S.) Frigorigène R-1234yf (Canada) YN-33-A (U.S.) HS7Z-19B519-BA (Canada)	WSS-M17B21-A
Motorcraft® R-1234yf Refrigerant PAG Oil (U.S.) Huile PAG pour frigorigène R-1234yf Motorcraft® (Canada) YN-35 (U.S. & Canada)	WSS-M2C300-A2
Motorcraft® Multi-Purpose Grease Spray (U.S.) Graisse tout usage en aérosol Motorcraft® (Canada) XL-5-A (U.S. & Canada)	ESB-MIC93-B
Motorcraft® Penetrating and Lock Lubricant (U.S.) Liquide dégrissant Motorcraft® (Canada) XL-1 (U.S.) CXC-51-A (Canada)	-

Note: Do not use more than 1.1 qt (1 L) of the alternative engine oil between scheduled service intervals.

Using oil and fluids that do not meet the defined specification and viscosity grade may lead to:

- Component damage which may not be covered by the vehicle Warranty.
- Longer engine cranking periods.
- Increased emission levels.
- Reduced engine performance.
- Reduced fuel economy.
- Reduced brake performance.

Do not use supplemental engine oil additives because they are unnecessary and could lead to engine damage that may not be covered by the vehicle Warranty.

Scheduled Maintenance

GENERAL MAINTENANCE INFORMATION

Protecting Your Investment

Your vehicle is equipped with an intelligent oil life monitoring system. Under normal operating conditions, a message appears in the information display to indicate the regular oil change interval. High performance vehicles tend to be driven in such a way that the engine experiences high speed and high load. As a result, some oil consumption could occur and the message appears earlier than the regular oil change interval. If you drive your vehicle this way, we recommend that you check the engine oil level every 2,000 mi (3,000 km) and fill the engine to the maximum mark on the engine oil dipstick.

Note: *Do not add oil further than the maximum mark.*

Index

A

About This Supplement.....	3
ABS	
See: Brakes.....	18
Air Filter	
See: Changing the Engine Air Filter.....	28
All-Wheel Drive.....	13
At a Glance.....	5
AWD	
See: All-Wheel Drive.....	13

B

Brakes.....	18
General Information.....	18
Brake System Specifications.....	38

C

Capacities and Specifications.....	41
Adding Engine Oil.....	42
Specifications.....	42
Car Wash	
See: Cleaning the Exterior.....	31
Changing the Engine Air Filter.....	28
Cleaning the Exterior.....	31
Cleaning Vehicle Wrap.....	31

D

Drive Belt Routing.....	29
Drive Control.....	20
Enhanced Torque Vectoring Control.....	21
Selectable Drive Modes.....	20
Suspension Damping.....	21
Driving Aids.....	20
Driving Hints.....	23
Driving Through Water.....	23

E

Engine Oil Dipstick.....	28
Engine Overboost.....	23
Engine Overspeed.....	23
Engine Specifications.....	36

F

Ford Performance.....	4
Fuel and Refueling.....	11
Fuel Quality.....	11
Choosing the Right Fuel.....	11
Fuses.....	25
Fuse Specification Chart.....	25
Engine Compartment Fuse Box.....	25
Luggage Compartment Fuse Box.....	26

G

Gauges.....	7
Oil Pressure Gauge.....	7
Oil Temperature Gauge.....	7
Turbocharger Boost Gauge.....	7
Gearbox	
See: Transmission.....	12
General Maintenance Information.....	44
Protecting Your Investment.....	44

I

Information Displays.....	8
General Information.....	8
Information Messages.....	8
All-Wheel Drive.....	9
Electronic Stability Control.....	9
Message Indicator.....	8
Instrument Cluster.....	7
Introduction.....	3

M

Maintenance.....	27
Manual Seats.....	10
Manual Transmission.....	12
Recommended Shift Speeds.....	12
Message Center	
See: Information Displays.....	8
Motorcraft Parts.....	41

R

Roadside Emergencies.....	24
---------------------------	----

Index

S

Scheduled Maintenance.....	44
Seats.....	10
Stability Control.....	19
Steering Specifications.....	39
Suspension Specifications.....	40
SVT.....	3

T

Team RS.....	3
Technical Specifications	
See: Capacities and Specifications.....	36
Tire Pressures.....	35
Tires.....	33
Tires	
See: Wheels and Tires.....	32
Towing a Trailer.....	22
Towing.....	22
Track Use.....	30
After Track Use.....	30
Before Track Use.....	30
Steering Assistance.....	30
Transmission Code Designation.....	41
Transmission Specifications.....	37
Transmission.....	12
Transporting the Vehicle.....	24

U

Under Hood Overview.....	27
Unique Features.....	5
Chassis.....	6
Exterior.....	6
Interior.....	6
Powertrain.....	5
Using All-Wheel Drive.....	13
Driving in Special Conditions.....	14
Using Mismatched Tires or Wheels.....	13
Using Stability Control.....	19
Switching Sport Mode On.....	19
Switching the System Off.....	19
Using Summer Tires.....	34
Storing Summer Tires.....	34
Using Winter Tires.....	34

V

Vehicle Care.....	31
-------------------	----

W

Warning Lamps and Indicators.....	7
Performance Shift Indicator.....	7
Washers	
See: Cleaning the Exterior.....	31
Wheels and Tires.....	32
Wheels.....	32
Winter Tires	
See: Using Winter Tires.....	34

