

PRO TRAILER BACKUP ASSIST WITH TRAILER REVERSE GUIDANCE STICKER PLACEMENT

PLACEMENT TIPS

- Perform sticker placement when temperatures are above 32°F (0°C).
- Clean the trailer.
- Place the sticker:
 - On a flat, dry, horizontal surface.
 - Entire sticker must be visible to the camera located in the tailgate handle.
 - Within the green zone as shown below, between 4 in (10 cm) and 19 in (48 cm) from the trailer ball hitch.
 - Lengthwise on the trailer tongue.
- Once the sticker is in place, confirm that the sticker is visible using the touchscreen.

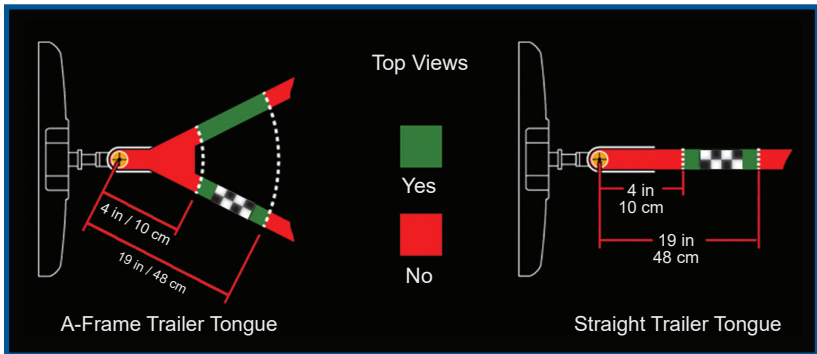

WARNING: Once placed, the sticker cannot be moved. Do not attempt to reuse stickers if removed.

Scan the QR code for additional information about your vehicle.



owner.ford.com



ford.ca



RB3J 19G217 HA

CARD/STICKERS POCKET (SLEEVE)

IMPORTANT

The operation of the Pro Trailer Backup Assist™ with Trailer Reverse Guidance system depends on how and where you place the sticker.

- **DO NOT ATTEMPT TO PLACE THE STICKER UNTIL YOU READ THROUGH THIS GUIDE.**

Please scan the QR code for additional information about your vehicle.



owner.ford.com



ford.ca

This Quick Start Guide is not intended to replace your vehicle Owner's Manual, which contains more detailed information concerning the features of your vehicle, as well as important safety warnings designed to help reduce the risk of injury to you and your passengers. Please read your entire Owner's Manual carefully as you begin learning about your new vehicle and refer to the appropriate chapters when questions arise. All information contained in this Quick Start Guide was accurate at the time of duplication. We reserve the right to change features, operation and/or functionality of any vehicle specification at any time. Your Ford dealer is the best source for the most current information. For detailed operating and safety information, please consult your Owner's Manual.

WARNING:

Driving while distracted can result in loss of vehicle control, crash and injury. We strongly recommend that you use extreme caution when using any device that may take your focus off the road. Your primary responsibility is the safe operation of your vehicle. We recommend against the use of any hand-held device while driving and encourage the use of voice-operated systems when possible. Make sure you are aware of all applicable local laws that may affect the use of electronic devices while driving.

LEARN MORE ABOUT YOUR NEW VEHICLE

To put QR tags to work for you, use your mobile phone's browser or app store to download a QR tag reader. Then follow the directions to scan the QR tag and see your vehicle's features come to life.



owner.ford.com



ford.ca

United States Ford Customer Relationship Center

1-800-392-3673 (FORD)
TDD for the hearing impaired:
7-1-1 (where offered by your
telephone service provider)

owner.ford.com



@FordService

Canada Ford Customer Relationship Centre

1-800-565-3673 (FORD)
TDD for the hearing impaired:
7-1-1 (where offered by your
telephone service provider)

ford.ca



@FordServiceCA



June 2023
First Printing
Litho in U.S.A.
RB3J19G217 HA



PRO TRAILER BACKUP ASSIST WITH TRAILER REVERSE GUIDANCE

RANGER

QUICK START GUIDE

WHAT IS PRO TRAILER BACKUP ASSIST WITH TRAILER REVERSE GUIDANCE?

The Pro Trailer Backup Assist with Trailer Reverse Guidance utilizes the control knob on your center console, your steering wheel and a suite of cameras to take the guesswork out of getting your trailer positioned where you want it, quickly and easily, while you're driving in reverse.

Turn the knob in the direction you want the trailer to go and the system takes over the steering to get it there. This allows you to focus on monitoring the mirrors, applying the brake, or accelerator as needed. Use the cameras and on-screen guidance to make even the most difficult maneuvers simple. This guide walks you through the setup process, calibration and operation.

Below is some of the added functionality that Pro Trailer Backup Assist with Trailer Reverse Guidance provides:

TRAILER REVERSE GUIDANCE CAMERA*



See the camera view on the side where the trailer is moving, or both sides when the trailer is straight behind you.

Does not require setup.

STEER TRAILER WITH KNOB



Allows you to easily maneuver a trailer by turning the knob in the direction you want the trailer to go.



See page 12 for operation.

Setup required.

HITCH ANGLE GRAPHIC

A small top view representation of your vehicle and trailer.

The lines show you where the trailer is and where it is projected to go.

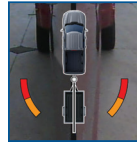

See page 16 for operation.

AUTO SPLIT VIEW CAMERA*



Changes views with the trailer direction.

See page 15 for operation.

STRAIGHT BACKUP MODE*



If you want to use the steering wheel:

A steering wheel image shows you which way to turn the steering wheel to keep your trailer straight.

See page 14 for operation.

*IF EQUIPPED

HOW DO I USE IT?

Set up this feature by following the steps in this guide. Scan the QR code on the back cover with your smartphone for more information about your vehicle.

TRAILER TYPE

Page 3

SET UP THE SYSTEM

Page 4

POSITION YOUR VEHICLE AND TRAILER

Page 5

SETUP OPTIONS

Page 6

SETTING UP YOUR TRAILER WITH A STICKER

STICKER SETUP

Page 7

PLACING THE STICKER

Page 8

CALIBRATION

Page 11

FEATURE OPERATION USING PRO TRAILER BACKUP ASSIST

Page 12

FEATURE OPERATION USING TRAILER REVERSE GUIDANCE

Page 14

VIEW OPERATION

Page 15

HITCH ANGLE GRAPHIC

Page 16

TO SET UP THIS FEATURE:

A Pro Trailer Backup Assist control knob

B Touchscreen



1

Read this guide carefully and follow the instructions to place the sticker or correctly install the sensor. Doing so allows you to complete the one-time trailer setup process.

2

TRAILER TYPE

The system only works with conventional trailers. It does not work with other types, including fifth-wheel and gooseneck. Use the images to the right to help you determine your trailer type.

Note: The system is designed to work with trailers that have a hitch point to the center of the axle or axles with a measurement of 6-33 ft (1.85-10.05 m). The system is designed to work with drawbars that have a license plate to hitch ball center measurement of 9-18 in (23-46 cm) when installed.

CONVENTIONAL TRAILER EXAMPLES

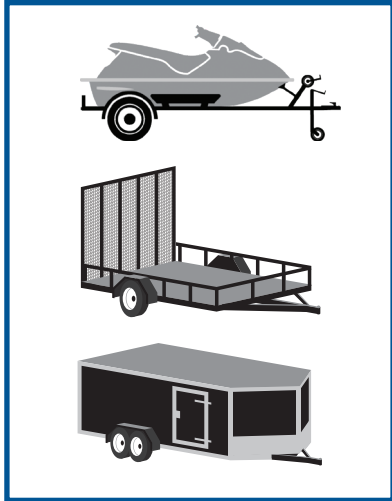

NON-CONVENTIONAL TRAILER EXAMPLES

The functionality of Pro Trailer Backup Assist with Trailer Reverse Guidance is not available for fifth wheel and gooseneck type trailers.



SET UP THE SYSTEM



Press the center button on the knob located on the center console to begin setting up the system.

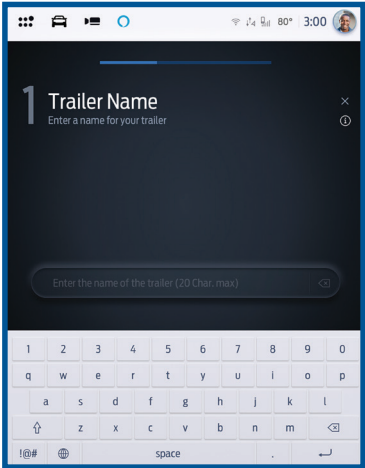

Select **Add Trailer** on the touchscreen.

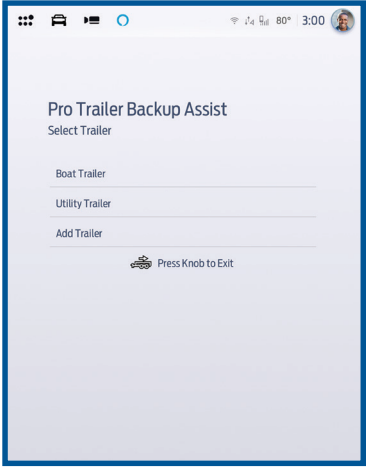

Use the keyboard on the touchscreen to enter the trailer name, then press the return button to confirm.

POSITION YOUR VEHICLE AND TRAILER

Read and follow all of these steps carefully to get the best results.

- Hitch the trailer to your vehicle and connect the electrical wiring harness. Check to make sure that the wiring is working.
- Park your vehicle and hitched trailer on a level surface.



- Make sure that the trailer and vehicle are in line with each other. You can do this by putting the transmission in drive (D) and pulling straight forward.



SETUP OPTIONS

Your trailer can be set up with a sticker that is provided with this guide. Follow the instructions in the next section of this guide to place your sticker and set up your trailer. For information on how to use a sensor instead of a sticker, see your Owner's Manual.

ONE-TIME SETUP

Once you input your trailer's information into the touchscreen, it is stored for easy recall. That way, when you want to use the Pro Trailer Backup Assist with Trailer Reverse Guidance system to help you back your trailer into your desired position, you can choose it from the touchscreen. You do not have to run through this setup again unless you want to add another trailer. You can store information for up to 10 trailers within this feature.



STICKER SETUP

MAKE SURE YOU HAVE THE FOLLOWING ITEMS:

This guide with the sticker placement card and the stickers in the inside back cover pocket.



Tape measure (English or metric)

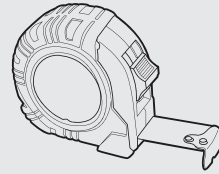

For more information about your vehicle, please scan the QR code below



owner.ford.com



ford.ca

PLACING THE STICKER

Place the entire sticker in the green zone on the trailer as outlined in the diagram on page 10. The sticker is in the back cover pocket of this guide.

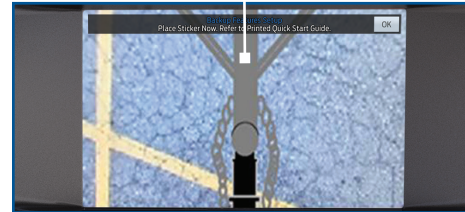

Rear view camera

MAKE SURE YOU GATHER THE FOLLOWING ITEMS BEFORE EXITING THE VEHICLE:

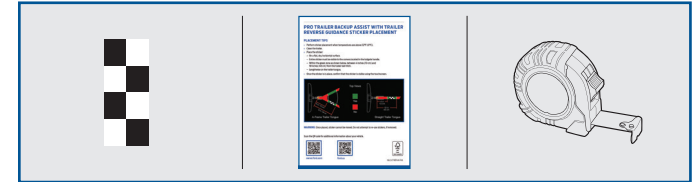

Sticker and sticker placement card (provided inside the back cover pocket of this guide).

Tape measure (not provided).

PLACING THE STICKER

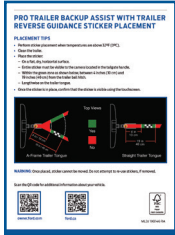

OUTSIDE THE VEHICLE

- Take the sticker placement card and the sticker from the back of this guide, and a tape measure, and walk back to the trailer.
- Place the sticker in the green zone as indicated in the diagram on the following page.
- Confirm that the sticker is visible using the touchscreen. An assistant can remain inside the vehicle to help you do this.

STICKER PLACEMENT TIPS

- Perform sticker placement when temperatures are above 32° F (0° C).
- Put the sticker on a flat, dry, clean horizontal surface.
- Using a tape measure, find a place to put the entire sticker in the range as shown below:
 - Within the green zone.
 - Between 4 - 20 in (10 - 50 cm) from the trailer ball hitch.
- Make sure no hardware obstructs the view from the camera to the sticker such as a jack handle or wiring.
- Place the sticker.

STICKER PLACEMENT DIAGRAM

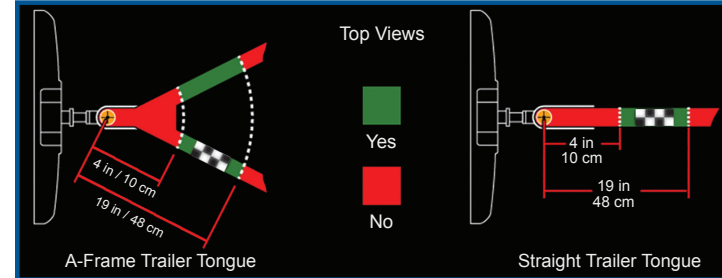

Note: Place the *entire sticker* within the green zone. Once you place the sticker, you cannot move it. Do not attempt to reuse stickers. Use a new sticker.

If you cannot find a location that meets the sticker requirements, the sensor is recommended.



CALIBRATION

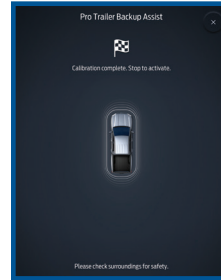
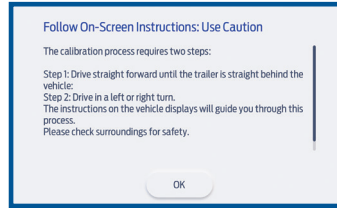
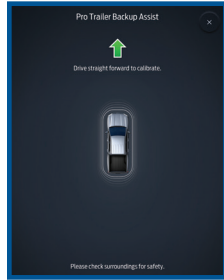

Note: You can calibrate within the Pro Trailer Backup Assist or Trailer Reverse Guidance system. Find an area where you can safely drive forward and turn left or right to calibrate the system. An open parking lot is an ideal place to perform the calibration. During calibration, the system determines the hitch position and trailer length. Drive straight at approximately 2-9 mph (4-15 km/h) to align the trailer behind your vehicle.

The touchscreen provides you with instructions and tells you when the system is ready for you to turn. Turn left or right whenever you are ready and in a safe turning area. Calibrating a trailer with the sticker setup requires a straight drive and turn followed by another straight drive and turn. Longer trailers could require a 180° turn. Some trailers could require you to drive straight then turn multiple times before calibration is complete.



 Too shallow of a turn

 Correct 90 degree turn

When the calibration is complete, the touchscreen displays a message that calibration is complete. The feature is now ready to use.

FEATURE OPERATION

USING PRO TRAILER BACKUP ASSIST

- Press the center button of the drive mode selector to switch on the Pro Trailer Backup Assist. Use the touchscreen to select the connected trailer. The system detects the trailer and instructs you to shift into reverse (R) when ready.
- Shift into reverse (R) to activate. The touchscreen instructs you to remove your hands from the steering wheel.
- Use the knob to turn the trailer. Turning the knob to the left turns the trailer to the left. Turning the knob to the right turns the trailer to the right.



FEATURE OPERATION

USING TRAILER BACKUP ASSIST

- Once you have the trailer moving in the direction you want it to go, release the knob. You control the accelerator and brakes while the system steers the vehicle to keep the trailer moving straight back.
- The sharper you turn the knob, the sharper the trailer turns.

Note: If you attempt to accelerate beyond the system's threshold, the system automatically limits your vehicle's speed.

Note: If you use the steering wheel when using trailer backup assistance, the system turns off and a message displays in the touchscreen.

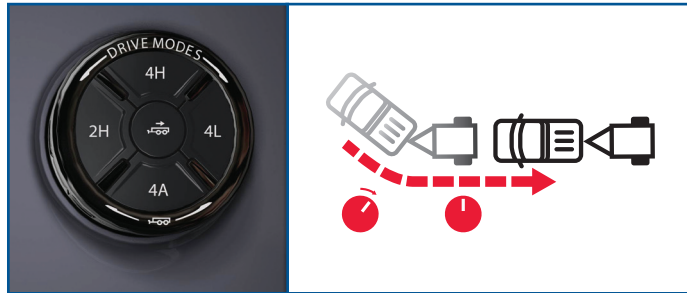

- As soon as you release the knob or turn it back to the center position, the vehicle starts following the trailer's path.
- Turn and hold the knob continuously for sharper vehicle and trailer turns.
- **CAUTION:** Always keep your hand close to the control knob. You may need to quickly redirect the trailer.
- You may have to use the knob to correct the trailer direction while attempting to move the trailer straight back under some conditions.

Note: If you need to make a sharper you can increase the trailer angle limit in the touchscreen towing menu. Refer to your Owner's Manual for selecting the trailer angle limit setting.

FEATURE OPERATION

USING TRAILER REVERSE GUIDANCE

Trailer Reverse Guidance provides informational graphics and up to seven camera views to help you back up the trailer while using the steering wheel to control the trailer.

If you do not set up the system, you can still use the camera views. However, the hitch angle graphic, automatic view switching and straight backup mode are not available. Complete the system setup for full functionality.



- To use Trailer Reverse Guidance, shift your vehicle into reverse (R) and press the rear view camera button on the touchscreen to expand the menu.

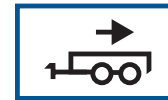

- Select the Trailer Reverse Guidance icon on the screen. Select your trailer from the touchscreen.
- The system detects the trailer and displays the hitch angle graphic.
- The auto mode camera view is the default display. You can now use your steering wheel and the camera views to navigate your trailer into position.



USING STRAIGHT BACKUP MODE WITH TRAILER REVERSE GUIDANCE

- This view is only available when you are in Trailer Reverse Guidance.
- This mode shows you which way to turn your steering wheel to keep the trailer straight. A steering wheel icon is displayed on the touchscreen. A blue arrow shows you which way to turn the wheel to keep the trailer straight.
- To activate this mode, select the rearview camera icon, then the straight backup mode icon.

VIEW OPERATION

Use the buttons below to select the best view for backing up your vehicle and trailer. You can use these views for Pro Trailer Backup Assist or Trailer Reverse Guidance.

You can select the following views by selecting the rear camera menu icon  on the touchscreen. The view drawer displays. (View drawer shown.)



360 degree camera*: shows the rear camera view on the left side of the screen and the 360 degree view on the right side of the screen.



Rear view camera: shows your trailer hitch or what is directly behind your vehicle.



Trailer Reverse Guidance view*: shows you a view of the sides of your vehicle and your trailer.



In auto mode, this view moves as your trailer moves so that you do not have to adjust the camera as you turn. You can use the left and right arrows to see more of the driver or passenger side. Press **Auto** to return to automatic camera adjustments.



Takes you back to the 360 degree camera system and out of the Trailer Reverse Guidance feature.

HITCH ANGLE GRAPHIC

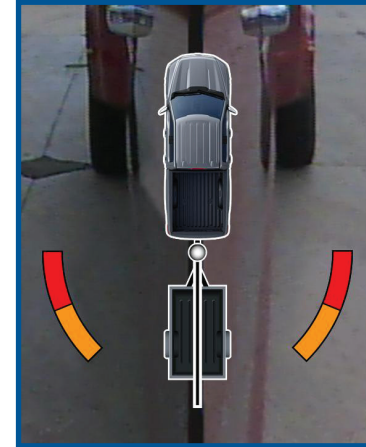

The hitch angle graphic shows you a small, top-view representation of your vehicle and trailer.

This representation shows two different-colored lines:

- A black line shows you where your trailer is in relation to your vehicle.
- For Pro Trailer Backup Assist, the white line represents the amount the trailer turns based on knob input.
- For Trailer Reverse Guidance, the white line represents the amount the trailer turns based on steering wheel position.
- The yellow zone indicates you are approaching the maximum controllable trailer angle for the system. It may be necessary to put your vehicle back into drive (D) and pull forward to get the truck and trailer back to an in-line position.
- The red zone indicates you have exceeded the maximum controllable trailer angle for the system. Immediately stop reversing. Put your vehicle into drive (D) and pull forward until the trailer is no longer in the red zone.

This graphic can be seen in the normal rear view, bed camera, trailer AUX camera and Trailer Reverse Guidance camera views.

