

# FORD **TOURNEO CONNECT** / **TRANSIT CONNECT** Owner's Manual





The information contained in this publication was correct at the time of going to print. In the interest of continuous development, we reserve the right to change specifications, design or equipment at any time without notice or obligation. No part of this publication may be reproduced, transmitted, stored in a retrieval system or translated into any language in any form by any means without our written permission. Errors and omissions excepted.

© Ford Motor Company 2018

All rights reserved.

Part Number: CG3750en 201804 20181211150431



# Table of Contents

---

## Introduction

About This Manual .....	7
Symbols Glossary .....	7
Data Recording .....	9
Replacement Parts Recommendation .....	12
Special Notices .....	13
Mobile Communications Equipment .....	13

## Environment

Protecting the Environment .....	14
----------------------------------	----

## At a Glance

Instrument Panel Overview - RHD .....	15
Instrument Panel Overview - LHD .....	16

## Child Safety

Installing Child Restraints .....	18
Child Restraint Positioning .....	22
Child Safety Locks .....	26

## Seatbelts

Fastening the Seatbelts .....	27
Seatbelt Height Adjustment .....	27
Seatbelt Reminder .....	28

## Supplementary Restraints System

Principle of Operation .....	30
Driver Airbag .....	30
Passenger Airbag .....	31
Switching the Passenger Airbag On and Off .....	31
Side Airbags .....	32
Side Curtain Airbags .....	33

## Automatic Crash Notification System

Emergency Assistance .....	34
----------------------------	----

## MyKey™

Principle of Operation .....	37
MyKey Settings .....	37
Creating a MyKey - Vehicles Without: Push Button Start .....	38
Creating a MyKey - Vehicles With: Push Button Start .....	38
Programming a MyKey .....	39
Clearing All MyKeys .....	41
Checking MyKey System Status .....	41
Using MyKey With Remote Start Systems .....	42
MyKey – Troubleshooting - Vehicles Without: Push Button Start .....	42
MyKey – Troubleshooting - Vehicles With: Push Button Start .....	42

## Keys and Remote Controls

General Information on Radio Frequencies .....	44
Remote Control - Vehicles With: Keyless Entry and Push Button Start .....	44
Remote Control - Vehicles With: Remote Flip Key .....	46
Replacing a Lost Key or Remote Control .....	48
Passive Key Backup Position .....	48

## Doors and Locks

Locking and Unlocking .....	49
Sliding Door .....	53
Keyless Entry .....	53

## Liftgate

Manual Liftgate .....	56
-----------------------	----

## Security

Passive Anti-Theft System .....	57
Anti-Theft Alarm .....	57

# Table of Contents

## Steering Wheel

Adjusting the Steering Wheel .....	59
------------------------------------	----

## Wipers and Washers

Windshield Wipers .....	60
Autowipers .....	60
Windshield Washers .....	62
Rear Window Wiper and Washers .....	62

## Lighting

General Information .....	63
Lighting Control .....	63
Autolamps .....	64
Instrument Lighting Dimmer .....	65
Headlamp Exit Delay .....	65
Automatic High Beam Control .....	65
Front Fog Lamps .....	67
Rear Fog Lamps .....	67
Headlamp Leveling .....	68
Cornering Lamps .....	68
Direction Indicators .....	69
Interior Lamps .....	69

## Windows and Mirrors

Power Windows - Vehicles With: Rear Power Windows .....	71
Power Windows - Vehicles With: One-Touch Open Driver Window .....	72
Global Opening and Closing .....	72
Exterior Mirrors .....	72
Interior Mirror - Vehicles Without: Auto-Dimming Interior Mirror .....	73
Interior Mirror - Vehicles With: Auto-Dimming Interior Mirror .....	73
Sun Shades .....	74

## Instrument Cluster

Gauges .....	75
Warning Lamps and Indicators .....	76

Audible Warnings and Indicators - Manual Transmission .....	79
Audible Warnings and Indicators - Automatic Transmission .....	79

## Information Displays

General Information .....	80
Trip Computer .....	82
Personalized Settings .....	82
Information Messages .....	82

## Climate Control

Manual Climate Control .....	95
Automatic Climate Control .....	96
Hints on Controlling the Interior Climate - Vehicles With: Automatic Temperature Control .....	97
Hints on Controlling the Interior Climate - Vehicles With: Manual Temperature Control .....	98
Heated Windshield .....	99
Heated Rear Window .....	99
Heated Exterior Mirrors .....	99
Auxiliary Heater .....	99
Remote Start .....	103

## Seats

Sitting in the Correct Position .....	105
Head Restraints .....	105
Manual Seats .....	107
Rear Seats - Short Wheelbase .....	111
Rear Seats - Long Wheelbase .....	113
Heated Seats .....	116

## Auxiliary Power Points

Auxiliary Power Points .....	118
Cigar Lighter .....	118
Wireless Accessory Charging .....	119

## Storage Compartments

Cup Holders .....	120
-------------------	-----

# Table of Contents

---

Overhead Console .....	120
Folding Tray .....	120
Under Seat Storage .....	121
Instrument Panel Storage Compartment .....	121

## Starting and Stopping the Engine

General Information .....	122
Ignition Switch .....	122
Push Button Ignition Switch .....	123
Steering Wheel Lock - Vehicles Without: Push Button Start .....	126
Steering Wheel Lock - Vehicles With: Push Button Start .....	126
Starting a Gasoline Engine - Automatic Transmission .....	126
Starting a Gasoline Engine - Manual Transmission .....	129
Starting a Diesel Engine - Automatic Transmission .....	132
Starting a Diesel Engine - Manual Transmission .....	134
Switching Off the Engine .....	136
Engine Block Heater .....	136

## Unique Driving Characteristics

Auto-Start-Stop - Automatic Transmission .....	138
Auto-Start-Stop - Manual Transmission .....	139
EcoSelect .....	141

## Fuel and Refueling

Safety Precautions .....	142
Fuel Quality - Gasoline .....	142
Fuel Quality - Diesel .....	143
Fuel Filler Funnel Location .....	143
Running Out of Fuel .....	143
Refueling .....	145
Fuel Consumption .....	148

## Engine Emission Control

Catalytic Converter - Gasoline .....	149
Selective Catalytic Reductant System .....	149
Gasoline Particulate Filter .....	153
Diesel Particulate Filter .....	154

## Transmission

Manual Transmission .....	160
Automatic Transmission .....	160

## Brakes

General Information .....	163
Hints on Driving With Anti-Lock Brakes .....	163
Parking Brake - Manual Transmission .....	163
Parking Brake - Automatic Transmission .....	164
Hill Start Assist .....	164

## Traction Control

Principle of Operation .....	166
Using Traction Control .....	166

## Stability Control

Principle of Operation .....	167
Using Stability Control .....	168

## Parking Aids

Principle of Operation .....	169
Rear Parking Aid .....	169
Front Parking Aid .....	171
Side Sensing System .....	173
Active Park Assist .....	175
Rear View Camera .....	182

## Cruise Control

Principle of Operation .....	185
Using Cruise Control .....	185

# Table of Contents

Using Adaptive Cruise Control .....	186	First Aid Kit .....	227
<b>Driving Aids</b>		Warning Triangle .....	227
Speed Limiter .....	192	Fuel Shutoff .....	227
Intelligent Speed Limiter .....	193	Jump Starting the Vehicle .....	228
Driver Alert .....	194	Towing Points .....	230
Lane Keeping System .....	196	<b>Fuses</b>	
Blind Spot Information System .....	200	Fuse Box Locations .....	232
Cross Traffic Alert .....	202	Fuse Specification Chart .....	233
Traffic Sign Recognition .....	205	Changing a Fuse .....	238
Speed Sign Recognition .....	207	<b>Maintenance</b>	
Eco Mode .....	208	General Information .....	240
Pre-Collision Assist .....	209	Opening and Closing the Hood .....	240
<b>Load Carrying</b>		Under Hood Overview - 1.0L EcoBoost™ .....	242
General Information .....	214	Under Hood Overview - 1.5L Duratorq-TDCi Diesel, LHD .....	243
Luggage Anchor Points .....	214	Under Hood Overview - 1.5L Duratorq-TDCi Diesel, RHD .....	244
Rear Under Floor Storage .....	215	Engine Oil Dipstick - 1.0L EcoBoost™ .....	245
Cargo Nets .....	215	Engine Oil Dipstick - 1.5L Duratorq-TDCi Diesel .....	245
Roof Racks and Load Carriers .....	217	Engine Oil Check .....	245
Folding Bulkhead .....	218	Oil Change Indicator Reset .....	246
<b>Towing</b>		Engine Cooling Fan - Gasoline .....	246
Towing a Trailer .....	221	Engine Cooling Fan - Diesel .....	246
Trailer Sway Control .....	222	Engine Coolant Check .....	246
Towing the Vehicle on Four Wheels - Manual Transmission .....	222	Automatic Transmission Fluid Check .....	247
Towing the Vehicle on Four Wheels - Automatic Transmission .....	223	Brake Fluid Check .....	248
<b>Driving Hints</b>		Clutch Fluid Check - Manual Transmission .....	248
Breaking-In .....	224	Washer Fluid Check .....	248
Reduced Engine Performance .....	224	Changing the 12V Battery .....	249
Economical Driving .....	224	Checking the Wiper Blades .....	249
Cold Weather Precautions .....	225	Changing the Front Wiper Blades .....	249
Driving Through Water .....	225	Changing the Rear Wiper Blades - Vehicles With: Manual Liftgate .....	250
Floor Mats .....	225		
<b>Roadside Emergencies</b>			
Hazard Flashers .....	227		

# Table of Contents

Changing the Rear Wiper Blades - Vehicles With: Rear Cargo Doors .....	250
Changing a Bulb .....	250

## Vehicle Care

Cleaning the Exterior .....	256
Cleaning the Interior .....	257
Repairing Minor Paint Damage .....	259
Cleaning the Wheels .....	259

## Wheels and Tires

General Information .....	260
Tire Sealant and Inflator Kit .....	260
Tire Care .....	264
Using Winter Tires .....	265
Using Snow Chains .....	265
Tire Pressure Monitoring System .....	266
Changing a Road Wheel .....	270
Tire Pressures .....	276
Tire Pressures .....	277
Tire Pressures .....	278
Tire Pressures .....	280
Lug Nuts .....	281

## Capacities and Specifications

Vehicle Dimensions - Long Wheelbase Com Kombi .....	282
Vehicle Dimensions - Long Wheelbase Double Cab in Van, Transit .....	282
Vehicle Dimensions - Long Wheelbase .....	283
Vehicle Dimensions - Short Wheelbase Com Kombi .....	283
Vehicle Dimensions - Short Wheelbase Double Cab in Van, Transit .....	284
Vehicle Dimensions - Short Wheelbase .....	284
Towbar Dimensions .....	285
Vehicle Identification Plate .....	286
Vehicle Identification Number .....	287

Capacities and Specifications - 1.0L EcoBoost™ .....	287
Capacities and Specifications - 1.5L EcoBlue .....	290
Bulb Specification Chart .....	292
Fuel Consumption Figures .....	294
Fuel Consumption Figures - 1.0L EcoBoost™ .....	294
Fuel Consumption Figures - 1.5L EcoBlue .....	295

## Network Connectivity

Connecting the Vehicle to a Mobile Network .....	296
Network Connectivity - Troubleshooting .....	297

## Wi-Fi Hotspot

Creating a Wi-Fi Hotspot - Vehicles Without: SYNC 3 .....	299
Changing the Wi-Fi Hotspot Name or Password - Vehicles Without: SYNC 3 .....	299

## Audio System

Audio Unit - Vehicles Without: SYNC 3 .....	301
Audio Unit - Vehicles With: SYNC 3 .....	303
AM/FM Radio - Vehicles Without: SYNC 3 .....	304
Digital Radio - Vehicles Without: SYNC 3 .....	305
Audio Unit Clock and Date Displays - Vehicles Without: SYNC 3 .....	306
Connecting a Bluetooth Device - Vehicles Without: SYNC 3 .....	306
Streaming Bluetooth Audio - Vehicles Without: SYNC 3 .....	306
Playing Media From a USB Device - Vehicles Without: SYNC 3 .....	306
USB Port .....	307
Using Voice Recognition .....	307

# Table of Contents

---

## **SYNC™ 3**

General Information .....	308
Home Screen .....	311
Using Voice Recognition .....	311
Entertainment .....	316
Phone .....	318
Navigation .....	320
Apps .....	324
Settings .....	325
SYNC™ 3 Troubleshooting .....	333

## **Appendices**

Electromagnetic Compatibility .....	343
End User License Agreement .....	345
Declaration of Conformity .....	369

# Introduction

## ABOUT THIS MANUAL

Thank you for choosing Ford. We recommend that you take some time to get to know your vehicle by reading this manual. The more that you know about your vehicle, the greater the safety and pleasure you will get from driving it.



**WARNING:** Driving while distracted can result in loss of vehicle control, crash and injury. We strongly recommend that you use extreme caution when using any device that may take your focus off the road. Your primary responsibility is the safe operation of your vehicle. We recommend against the use of any hand-held device while driving and encourage the use of voice-operated systems when possible. Make sure you are aware of all applicable local laws that may affect the use of electronic devices while driving.

**Note:** This manual describes product features and options available throughout the range of available models, sometimes even before they are generally available. It may describe options not fitted to the vehicle you have purchased.

**Note:** Some of the illustrations in this manual may show features as used in different models, so may appear different to you on your vehicle.

**Note:** Always use and operate your vehicle in line with all applicable laws and regulations.

**Note:** Pass on this manual when selling your vehicle. It is an integral part of your vehicle.

This manual may qualify the location of a component as left-hand side or right-hand side. The side is determined when facing forward in the seat.

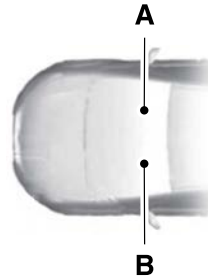

E154903

- A Right-hand side.
- B Left-hand side.

## SYMBOLS GLOSSARY

These are some of the symbols you may see on your vehicle.



Safety alert.



See the Owner's Manual.



Air conditioning system.



Anti-lock braking system.



Avoid smoking, flames or sparks.



Battery.



Battery acid.



Brake fluid level.

# Introduction

---



Brake system.



Brake failure.



Cabin air filter.



Check fuel cap.



Child safety door lock.



Child safety door unlock.



Child seat lower anchor.



Child seat tether anchor.



Cruise control.



Do not open when hot.



Electronic power steering malfunction.



Engine air filter.



Engine coolant.



Engine coolant temperature.



Engine oil.



Explosive gas.



Fan warning.



Fasten seatbelt.



Front airbag.



Front fog lamps.



Fuel pump reset.



Fuse compartment.



Hazard warning flashers.



Heated rear window.



Heated windshield.



Interior luggage compartment release.



Jack.



Keep out of reach of children.



Lighting control.



Low tire pressure warning.

# Introduction



Maintain correct fluid level.



Panic alarm.



Parking aid.



Parking brake.



Power steering fluid.



Power windows.



Power window lockout.



Check Engine.



Service engine soon.



Side airbag.



Shield the eyes.



Stability control.



Windshield wash and wipe.

## DATA RECORDING



**WARNING:** Do not connect wireless plug-in devices to the data link connector. Unauthorized third parties could gain access to vehicle data and impair the performance of safety related systems. Only allow repair facilities that follow our service and repair instructions to connect their equipment to the data link connector.

We respect your privacy and are committed to protecting it. The information contained in this publication was correct at the time of going to print but as technology rapidly changes, we recommend that you visit the local Ford website for the latest information.

Your vehicle has electronic control units that have data recording functionality and the ability to permanently or temporarily store data. This data could include information on the condition and status of your vehicle, vehicle maintenance requirements, events and malfunctions. The types of data that can be recorded are described in this section. Some of the data recorded is stored in event logs or error logs.

**Note:** *Error logs are reset following a service or repair.*

**Note:** *We may provide information in response to requests from law enforcement, other government authorities and third parties acting with lawful authority or through a legal process. Such information could be used by them in legal proceedings.*

# Introduction

---

Data recorded includes, for example:

- Operating states of system components, for example fuel level, tire pressure and battery charge level.
- Vehicle and component status, for example wheel speed, deceleration, lateral acceleration and seatbelt status.
- Events or errors in essential systems, for example headlamps and brakes.
- System responses to driving situations, for example airbag deployment and stability control.
- Environmental conditions, for example temperature.

Some of this data, when used in combination with other information, for example an accident report, damage to a vehicle or eyewitness statements, could be associated with a specific person.

## Service Data

Our dealers collect service data through the data link connector in your vehicle. They use service data, for example error logs, to help them if you take your vehicle for repair. They share this data with our technical team, if required, to help with diagnosis. In addition to using the information for diagnosis and repair, we use and share service data with our service providers, for example parts suppliers, where required and where permitted by law, for continuous improvement or with other information that we have about you, for example your contact information, to offer you products and services that may be of interest to you according to your preferences and where allowed by law. Our service providers are equally required by law to protect your data and retain it in accordance with data retention policies.

**Note:** *Third party repair facilities can also collect service data through the data link connector.*

## Event Data

This vehicle is equipped with an event data recorder. The main purpose of an event data recorder is to record, in certain crash or near crash-like situations, such as an airbag deployment or hitting a road obstacle; this data will assist in understanding how a vehicle's systems performed. The event data recorder is designed to record data related to vehicle dynamics and safety systems for a short period of time, typically 30 seconds or less.

The event data recorder in this vehicle is designed to record such data as:

- How various systems in your vehicle were operating;
- Whether or not the driver and passenger seatbelts were buckled/fastened;
- How far (if at all) the driver was depressing the accelerator and/or the brake pedal; and
- How fast the vehicle was traveling; and
- Where the driver was positioning the steering wheel.

This data can help provide a better understanding of the circumstances in which crashes and injuries occur.

**Note:** *Event data recorder data is recorded by your vehicle only if a non-trivial crash situation occurs; no data is recorded by the event data recorder under normal driving conditions and no personal data or information (e.g., name, gender, age, and crash location) is recorded. However, parties, such as law enforcement, could combine the event data recorder data with the type of personally identifying data routinely acquired during a crash investigation.*

# Introduction

---

To read data recorded by an event data recorder, special equipment is required, and access to the vehicle or the event data recorder is needed. In addition to the vehicle manufacturer, other parties, such as law enforcement, that have such special equipment, can read the information if they have access to the vehicle or the event data recorder.

## Comfort, Convenience and Entertainment Data

Your vehicle has electronic control units that have the ability to store data based on your personalized settings. The data is stored locally in the vehicle or on devices that you connect to it, for example, a USB drive or digital music player. You can delete some of this data and also choose whether to share it through the services to which you subscribe. See **Settings** (page 325).

### Comfort and Convenience Data

Data recorded includes, for example:

- Seat and steering wheel position.
- Climate control settings.
- Radio presets.

### Entertainment Data

Data recorded includes, for example:

- Music, videos or album art.
- Contacts and corresponding address book entries.
- Navigation destinations.

## Services That We Provide

If you use our services, we collect and use data, for example account information, vehicle location and driving characteristics, that could identify you. We transmit this data through a dedicated, protected connection. We only collect and use data

to enable your use of our services to which you have subscribed, with your consent or where permitted by law. For additional information, see the terms and conditions of the services to which you have subscribed.

For additional information about our privacy policy, refer to the local Ford website.

## Services That Third Parties Provide

We recommend that you review the terms and conditions and data privacy information for any services to which you subscribe. We take no responsibility for services that third parties provide.

## Vehicles With a Modem

The modem has a SIM. The modem periodically sends messages to stay connected to the cell phone network. These messages could include information that identifies your vehicle, the SIM and the electronic serial number of the modem. Cell phone network service providers could have access to additional information, for example cell phone network tower identification.

**Note:** *The modem continues to send this information unless you have all added value services deactivated. To find out more about having all added value services deactivated, search Ask Ford on the local Ford website or contact the Ford Customer Relationship Center by e-mail through the FordPass app or by using the e-mail address on the local Ford website.*

**Note:** *The service can be unavailable or interrupted for a number of reasons, for example environmental or topographical conditions and data plan coverage.*

# Introduction

---

## Vehicles With SYNC

### Mobile Device Data

If you connect a mobile device to your vehicle, you can display data from your device on the touchscreen for example, music and album art. You can share your vehicle data with mobile apps on your device through the system. See **Apps** (page 324).

The mobile apps function operates by your connected device sending data to us in the United States. The data is encrypted and includes the vehicle identification number of your vehicle, the SYNC module serial number, odometer, enabled apps, usage statistics and debugging information. We retain it only as long as necessary to provide the service, to troubleshoot, for continuous improvement and to offer you products and services that may be of interest to you according to your preferences and where allowed by law.

If you connect a cell phone to the system, the system creates a profile that links to that cell phone. The cell phone profile enables more mobile features and efficient operation. The profile contains, for example data from your phonebook, read and unread text messages and call history, including history of calls when your cell phone was not connected to the system.

If you connect a media device, the system creates and retains a media device index of supported media content. The system also records a short diagnostic log of approximately 10 minutes of all recent system activity.

The cell phone profile, media device index and diagnostic log remain in your vehicle unless you delete them and are generally accessible only in your vehicle when you connect your cell phone or media device. If you no longer plan to use the system or your vehicle, we recommend you use the master reset function to erase the stored information. See **Settings** (page 325).

System data cannot be accessed without special equipment and access to your vehicle's module.

For additional information about our privacy policy, refer to the local Ford website.

## REPLACEMENT PARTS RECOMMENDATION

We have built your vehicle to the highest standards using quality parts. We recommend that you demand the use of genuine Ford and Motorcraft parts whenever your vehicle requires scheduled maintenance or repair. You can clearly identify genuine Ford and Motorcraft parts by looking for the Ford, FoMoCo or Motorcraft branding on the parts or their packaging.

### Scheduled Maintenance and Mechanical Repairs

One of the best ways for you to make sure that your vehicle provides years of service is to have it maintained in line with our recommendations using parts that conform to the specifications detailed in this Owner's Manual. Genuine Ford and Motorcraft parts meet or exceed these specifications.

# Introduction

## Collision Repairs

We hope that you never experience a collision, but accidents do happen. Genuine Ford replacement collision parts meet our stringent requirements for fit, finish, structural integrity, corrosion protection and dent resistance. During vehicle development we validate that these parts deliver the intended level of protection as a whole system. A great way to know for sure you are getting this level of protection is to use genuine Ford replacement collision parts.

## Warranty on Replacement Parts

Genuine Ford and Motorcraft replacement parts are the only replacement parts that benefit from a Ford Warranty. The Ford Warranty may not cover damage caused to your vehicle as a result of failed non-Ford parts. For additional information, refer to the terms and conditions of the Ford Warranty.

hand-held device while driving and encourage the use of voice-operated systems when possible. Make sure you are aware of all applicable local laws that may affect the use of electronic devices while driving.

Using mobile communications equipment is becoming increasingly important in the conduct of business and personal affairs. However, you must not compromise your own or others' safety when using such equipment. Mobile communications can enhance personal safety and security when appropriately used, particularly in emergency situations. Safety must be paramount when using mobile communications equipment to avoid negating these benefits. Mobile communication equipment includes, but is not limited to, cellular phones, pagers, portable email devices, text messaging devices and portable two-way radios.

## SPECIAL NOTICES

If converting or modifying your vehicle from production specification, refer to the Body and Equipment Mounting Manual at [www.etis.ford.com/BEMM](http://www.etis.ford.com/BEMM).

## MOBILE COMMUNICATIONS EQUIPMENT



**WARNING:** Driving while distracted can result in loss of vehicle control, crash and injury. We strongly recommend that you use extreme caution when using any device that may take your focus off the road. Your primary responsibility is the safe operation of your vehicle. We recommend against the use of any

# Environment

---

## **PROTECTING THE ENVIRONMENT**

You should play your part in protecting the environment. Correct vehicle usage and the authorized disposal of waste, cleaning and lubrication materials are significant steps toward this aim.

**For details about Ford Motor Company's sustainability progress and initiatives visit:**

<b>Web Address</b>
<a href="http://www.sustainability.ford.com">www.sustainability.ford.com</a>

# At a Glance

## INSTRUMENT PANEL OVERVIEW - RHD

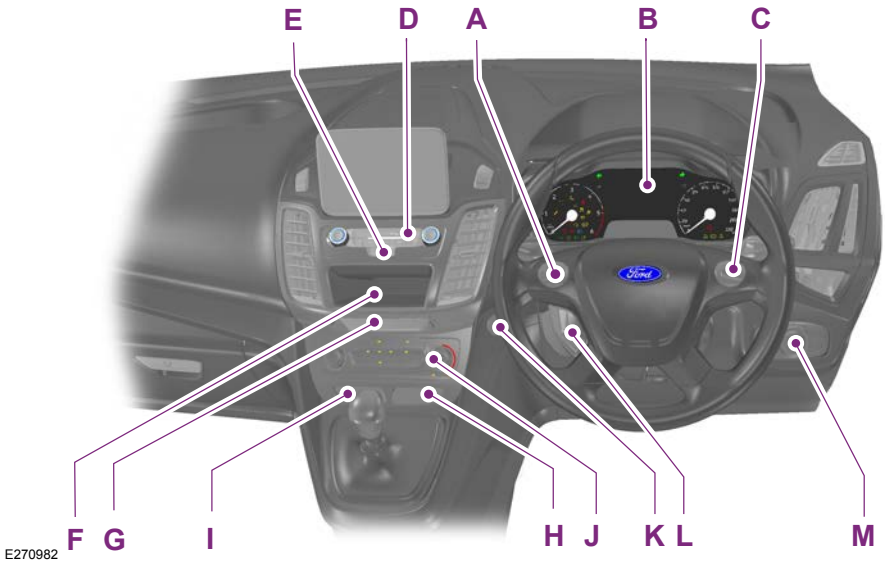

- A Information display controls. See **General Information** (page 80).
- B Instrument cluster. See **Gauges** (page 75).
- C Audio and voice control buttons.
- D Audio unit. See **Audio System** (page 301).
- E Hazard flasher switch. See **Hazard Flashers** (page 227).
- F Wireless accessory charging. See **Switching the Passenger Airbag On and Off** (page 31).
- G Passenger airbag deactivation indicator. See **Switching the Passenger Airbag On and Off** (page 31).
- H Auto-Start-Stop button. See **Auto-Start-Stop** (page 138). Parking aid button. See **Parking Aids** (page 169).
- I Traction control switch. See **Using Traction Control** (page 166). EcoSelect button. See **EcoSelect** (page 141).
- J Climate control. See **Climate Control** (page 95).
- K Push button ignition switch. See **Push Button Ignition Switch** (page 123).

# At a Glance

- L Cruise control buttons. See **Using Cruise Control** (page 185).
- M Lighting control. See **Lighting** (page 63).

## INSTRUMENT PANEL OVERVIEW - LHD

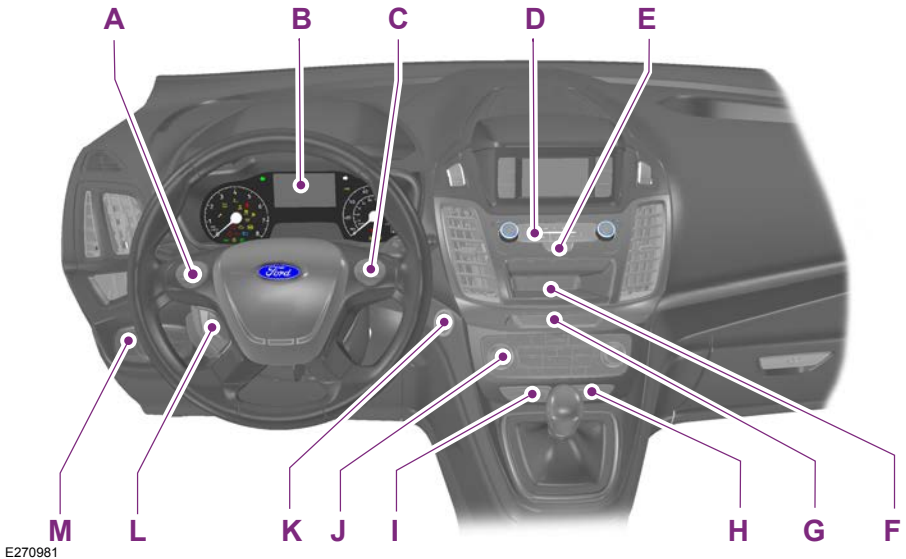

- A Information display controls. See **General Information** (page 80).
- B Instrument cluster. See **Gauges** (page 75).
- C Audio and voice control buttons.
- D Audio unit. See **Audio System** (page 301).
- E Hazard flasher switch. See **Hazard Flashers** (page 227).
- F Wireless accessory charging. See **Wireless Accessory Charging** (page 119).
- G Passenger airbag deactivation indicator. See **Switching the Passenger Airbag On and Off** (page 31).
- H Auto-Start-Stop button. See **Auto-Start-Stop** (page 138). Parking aid button. See **Parking Aids** (page 169).

## At a Glance

---

- I Traction control switch. See **Using Traction Control** (page 166). EcoSelect button. See **EcoSelect** (page 141).
- J Climate control. See **Climate Control** (page 95).
- K Push button ignition switch. See **Push Button Ignition Switch** (page 123).
- L Cruise control buttons. See **Using Cruise Control** (page 185).
- M Lighting control. See **Lighting** (page 63).

# Child Safety

## INSTALLING CHILD RESTRAINTS



E161855



E68916

**! WARNING:** Extreme Hazard!  
Never use a rearward facing child restraint on a seat protected by an active airbag in front of it. Death or serious injury to the child can occur.

**! WARNING:** You must switch the passenger airbag off when using a rearward facing child restraint on the front seat.

**! WARNING:** You must switch the passenger airbag on following the removal of the child restraint.

**! WARNING:** Read and follow the manufacturer's instructions when you are installing a child restraint.

**! WARNING:** Do not modify child restraints in any way.

**! WARNING:** Do not hold a child on your lap when your vehicle is moving.

**! WARNING:** Do not leave children or pets unattended in your vehicle. Failure to follow this instruction could result in personal injury or death.

**! WARNING:** If your vehicle has been involved in a crash, have the child restraints checked.

Only child restraints certified to ECE-R129 or ECE-R44.03 (or later) have been tested and approved for use in your vehicle. A choice of these are available from an authorized dealer.

**Note:** *Mandatory use of child restraints varies from country to country.*

When using a child restraint on a front seat, follow these seat positioning guidelines:

- The child restraint must not be in contact with the instrument panel.
- Position the passenger seat as far rearward as possible and route the seatbelt forward and downward from the B-pillar ring to the child restraint.
- If it proves difficult to tighten the lap section of the seatbelt without slack remaining, adjust the seat backrest to the fully upright position and raise the height of the seat.

**Note:** *When using a child restraint on a rear seat, adjust the front seat to a position to prevent contact with the child's feet or legs.*

# Child Safety

## Child Restraints for Different Mass Groups

Use the correct child restraint as follows:

### Baby Safety Restraint (Group 0+)



E68918

Secure children that weigh less than 13 kg (29 lb) in a rearward facing baby safety restraint (Group 0+) on the rear seat.

### Child Safety Restraint (Group 1)





E68920

Secure children that weigh between 13 kg (29 lb) and 18 kg (40 lb) in a child safety restraint (Group 1) on the rear seat.

## Booster Seats

 **WARNING:** Do not install a booster seat or a booster cushion with only the lap strap of the seatbelt.

 **WARNING:** Do not install a booster seat or a booster cushion with a seatbelt that is slack or twisted.

 **WARNING:** Do not put the shoulder section of the seatbelt or allow the child to put the shoulder section of the seatbelt under their arm or behind their back. Failure to follow this instruction could reduce the effectiveness of the seatbelt and increase the risk of injury or death in a crash.

 **WARNING:** Do not use pillows, books or towels to boost your child's height. Failure to follow this instruction could result in personal injury or death.

 **WARNING:** Make sure that your children sit in an upright position.

 **WARNING:** Make sure the child restraint rests tightly against the vehicle seat. If necessary, adjust the seat backrest to an upright position. It may also be necessary to lift or remove the head restraint.

 **WARNING:** You must reinstall the head restraint following the removal of the child restraint.

# Child Safety

## Booster Seat (Group 2)



E70710

Secure children that weigh greater than 15 kg (33 lb) but are less than 150 cm (60 in) tall in a booster seat or on a booster cushion.

We recommend that you use a booster seat that combines a cushion with a backrest instead of a booster cushion only. The raised seating position will allow you to position the shoulder strap of the adult seatbelt over the center of your child's shoulder and the lap strap tightly across their hips.

## Booster Cushion (Group 3)

**WARNING:** When using a booster cushion, make sure you adjust the vehicle head restraint on that seating position.



E68924

Secure children that weigh greater than 22 kg (49 lb) but are less than 150 cm (60 in) tall on a booster cushion.

## ISOFIX Anchor Points

**WARNING:** Use an anti-rotation device when using the ISOFIX system. We recommend the use of a top tether or support leg.

Your vehicle has ISOFIX anchor points that accommodate universally approved ISOFIX child restraints.

Always follow the manufacturer's instructions for installing a child restraint with a top tether.



E174928

The ISOFIX system has two rigid attachment arms on the child restraint. These attach to anchor points on the second row seats, where the cushion and backrest meet.

**Note:** If you are purchasing an ISOFIX child restraint, make sure that you know the correct mass group and ISOFIX size class for the intended seating locations. See **Child Restraint Positioning** (page 22).

# Child Safety

## Top Tether Anchor Points

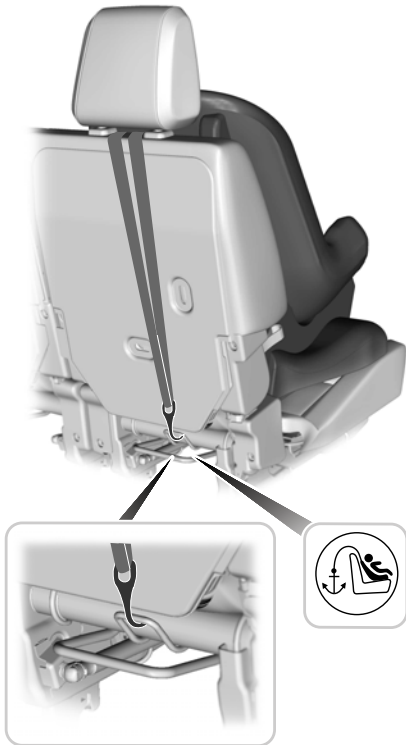

E165605

For child restraints with a top tether, tether anchor points are on the underside or back of the second row seats.

## Attaching a Child Restraint With Top Tethers

**WARNING:** Do not attach the top tether strap to anything other than the correct top tether strap anchor point.

**WARNING:** Make sure that the top tether strap is not slack or twisted and is properly located on the anchor point.

1. Attach the tether strap to the anchor point.

**Note:** Where applicable, remove the luggage cover to ease installation.

**Note:** You may need to lift or remove the head restraint to ease installation.



E87145

2. Push the child restraint back firmly to engage the ISOFIX lower anchor points.
3. Tighten the tether strap in line with the child restraint manufacturer's instructions.

## Attaching a Child Restraint With a Support Leg

**WARNING:** If you use a child restraint that has a support leg, make sure the support leg rests securely on the floor.

# Child Safety

**! WARNING:** Always make sure your child is secured properly in a device that is appropriate for their height, age and weight. Child safety restraints must be bought separately from your vehicle. Failure to follow these instructions and guidelines may result in an increased risk of serious injury or death to your child.

**! WARNING:** Make sure that the child restraint manufacturer lists your vehicle as suitable for use with this type of child restraint.



E185352

Always follow the manufacturer's instructions for installing a child restraint with a support leg.

## CHILD RESTRAINT POSITIONING

**! WARNING:** Extreme Hazard! Never use a rearward facing child restraint on a seat protected by an active airbag in front of it. Death or serious injury to the child can occur.

**! WARNING:** If you use a child restraint that has a support leg, make sure the support leg rests securely on the floor.

**! WARNING:** If you use a child restraint and a seatbelt, make sure that the seatbelt is not slack or twisted.

**! WARNING:** Make sure the child restraint rests tightly against the vehicle seat. If necessary, adjust the seat backrest to an upright position. It may also be necessary to lift or remove the head restraint.

**! WARNING:** You must reinstall the head restraint following the removal of the child restraint.

**Note:** When using a child restraint on a front seat, always adjust the front passenger seat as far back as possible. If it proves difficult to tighten the lap section of the seatbelt without slack remaining, adjust the seat backrest to the fully upright position and raise the height of the seat. See **Seats** (page 105).

# Child Safety

Seating positions	Mass group categories				
	0	0+	1	2	3
	Up to 22 lbs (10 kg)	Up to 29 lbs (13 kg)	20 - 40 lbs (9 - 18 kg)	33 - 55 lbs (15 - 25 kg)	46 - 79 lbs (22 - 36 kg)
Front passenger seat with airbag <b>ON</b>	X	X	UF <sup>1</sup>	UF <sup>1</sup>	UF <sup>1</sup>
Front passenger seat with airbag <b>OFF</b>	U <sup>1</sup>	U <sup>1</sup>	U <sup>1</sup>	U <sup>1</sup>	U <sup>1</sup>
Fold-flat front passenger seat with airbag <b>ON</b>	X	X	L <sup>1</sup>	L <sup>1</sup>	L <sup>1</sup>
Fold-flat front passenger seat with airbag <b>OFF</b>	X	L <sup>1</sup>	L <sup>1</sup>	L <sup>1</sup>	L <sup>1</sup>
Dual front passenger seat - center seat only	X	X	X	X	X
Second row rear seats	U	U	U	U	U
Third row rear seats	U	U	U	U	U

**X** Not suitable for children in this mass group.

**U** Suitable for universal category child restraints approved for use in this mass group.

**U<sup>1</sup>** Suitable for universal category child restraints approved for use in this mass group. We recommend that you secure children in a government approved child seat, on a rear seat.

**UF<sup>1</sup>** Suitable for universal category forward facing child seats approved for use in this mass group. We recommend that you secure children in a government approved child seat, on a rear seat.

**L<sup>1</sup>** Suitable only for the following child seats:

- Group 0+: Britax Baby-Safe Plus (E1-04301146) also with Britax Baby-Safe Belted Base (E1-04301146). Maxi-Cosi CabrioFix (E4-04443517) also with EasyBase 2 (E4-04443523) or EasyFix (E4-04443522).
- Group 1: Recaro Young Expert (E1-04301150). Britax Duo Plus (belted) (E1-04301133). Britax Safefix (belted) (E1-04301199).
- Group 2 and 3: Britax Kidfix (belted only) (E1-04301198). Britax Kid (E1-04301148).
- We recommend that you secure children in a government approved child seat, on a rear seat.

# Child Safety

## ISOFIX Child Seats

Seating positions		Mass group categories			
		0	0+	I	
		Rear facing		Forward facing	Rear facing
		Up to 29 lbs (13 kg)		20 - 40 lbs (9 - 18 kg)	
Front passenger seat	Size class	Not ISOFIX equipped			
	Size type				
Second row rear outboard seat ISOFIX	Size class	C, D, E <sup>1</sup>	A, B, B1 <sup>1</sup>	C, D <sup>1</sup>	
	Size type	IL	IL, IUF	IL	
Second row rear center seat	Size class	Not ISOFIX equipped			
	Size type				
Third row rear seats	Size class	Not ISOFIX equipped			
	Size type				

**IL** Suitable for use with particular ISOFIX child restraints systems in the semi-universal category. Refer to the child restraint system manufacturer vehicle recommendation list for additional information.

**IUF** Suitable for use with forward facing ISOFIX child restraints systems in the universal category.

<sup>1</sup>The capital letters A to G define the ISOFIX size class for both universal and semi-universal child restraints systems. You can see the identification letters on ISOFIX child restraints. See an authorized dealer for the latest details relating to our recommended child restraints.

# Child Safety

## Recommended Child Restraints

Mass Group Categories	Manufacturer	Model	Attachment
0+ 0–13 kg (0–29 lb)	Britax Römer.	Baby Safe Plus with ISOFIX base. <sup>1</sup>	ISOFIX base or seatbelt only.
1 9–18 kg (20–40 lb)	Britax Römer.	Duo Plus. <sup>1</sup>	ISOFIX and top tether anchors or seatbelt only.
2 15–25 kg (33–55 lb)	Britax Römer.	KidFix. <sup>1, 2</sup>	ISOFIX and seatbelt or seatbelt only.
3 22–36 kg (49–79 lb)	Britax Römer.	KidFix. <sup>1, 2</sup>	ISOFIX and seatbelt or seatbelt only.

<sup>1</sup>We recommend that you secure children using an ISOFIX child restraint on the rear outermost seats.

<sup>2</sup>We recommend that you use a booster seat that combines a cushion with a backrest instead of a booster cushion only.

See an authorized dealer for the latest details relating to our recommended child restraints.

## i-Size Child Restraints

	Front Passenger Seat	Rear Outermost Seats	Rear Center Seat	Third Row Seats
i-Size child restraint systems.	X	i-U	X	X

**i-U** Suitable for use with forward and rearward facing i-Size child restraint systems.

**X** Not suitable for use with i-Size child restraint systems.

# Child Safety

## CHILD SAFETY LOCKS



**WARNING:** You cannot open the rear doors from inside if you have put the child safety locks on.

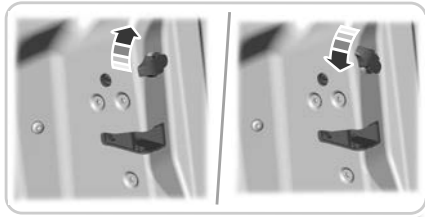

E189148

A child safety lock is on the rear edge of each rear door. You must set the child safety lock separately on each door.

### **Left-Hand Side**

Turn counterclockwise to lock and clockwise to unlock.

### **Right-Hand Side**

Turn clockwise to lock and counterclockwise to unlock.

# Seatbelts

## FASTENING THE SEATBELTS

 **WARNING:** Insert the tongue into the buckle until you hear a distinct click. You have not fastened the seatbelt correctly if you do not hear a click.

 **WARNING:** Make sure that the seatbelts are securely stowed away when not in use and not outside your vehicle when closing the doors.



E74124

1. Pull the seatbelt out steadily.

**Note:** It may lock if you pull it sharply or if the vehicle is on a slope.

2. Insert the tongue into the buckle until you hear a distinct click.

Press the red button on the buckle to release the seatbelt. Hold the seatbelt tongue and let it retract completely and smoothly to its stowed position.

## Using Seatbelts During Pregnancy

 **WARNING:** Position the seatbelt correctly for your safety and that of your unborn child. Do not use only the lap strap or the shoulder strap.

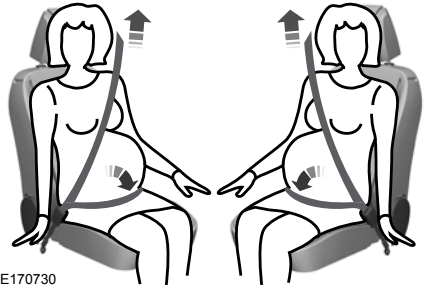

E170730

Pregnant women should always wear their seatbelt. The lap belt portion of a combination lap and shoulder belt should be positioned low across the hips below the belly and worn as tight as comfort will allow. The shoulder belt portion of a combination lap and shoulder belt should be positioned to cross the middle of the shoulder and the center of the chest.

## SEATBELT HEIGHT ADJUSTMENT

 **WARNING:** Position the seatbelt height adjuster so that the seatbelt rests across the middle of your shoulder. Failure to adjust the seatbelt correctly could reduce its effectiveness and increase the risk of injury in a crash.

# Seatbelts



The warning lamp illuminates until you fasten your seatbelt.

## Fasten Seatbelt Audible Warning

A warning tone sounds if the warning lamp illuminates and your vehicle exceeds a relatively low speed.

The warning tone sounds for up to five minutes or until you fasten your seatbelt.

## Switching the Audible Warning Off

We recommend that you contact an authorized dealer.

## Seatbelt Status

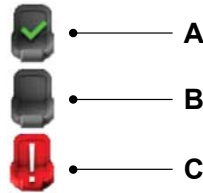

E267667

- A Seatbelt fastened.
- B Seatbelt not fastened.
- C Rear seatbelt recently unfastened.

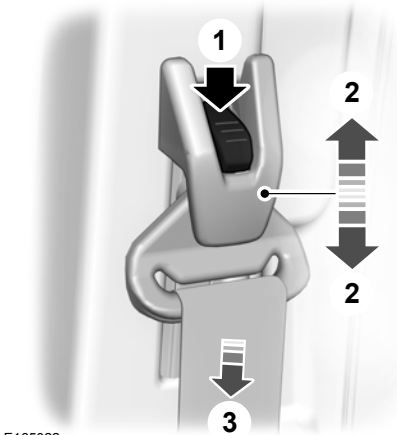

E165022

1. Press the button.
2. Slide the height adjuster up or down.
3. Release the button and pull down on the height adjuster to make sure it is locked in place.

## SEATBELT REMINDER

### Fasten Seatbelt Warning Lamp

A warning lamp illuminates if the ignition is on, a front seat is occupied and the seatbelt has not been fastened.

**To view the seatbelt status, use the information display controls on the steering wheel to select the following:**

Menu Item	Action
Settings	Press the menu button.
Information	Press the <b>OK</b> button.
Seatbelts	Press the <b>OK</b> button.

# Seatbelts

---

## Seatbelt Status Information Messages

<b>Message</b>	<b>Description</b>
Rear belt monitor malfunction Service required	The system has detected a fault that requires service. Have your vehicle checked as soon as possible.

# Supplementary Restraints System

## PRINCIPLE OF OPERATION

**WARNING:** Extreme Hazard!  
Never use a rearward facing child restraint on a seat protected by an active airbag in front of it. Death or serious injury to the child can occur.

**WARNING:** Do not modify the front of your vehicle in any way. This could adversely affect deployment of the airbags. Failure to adhere to this warning could result in serious personal injury or death.

**WARNING:** Wear a seatbelt and keep sufficient distance between yourself and the steering wheel. Only when you use the seatbelt correctly, can it hold you in a position that allows the airbag to achieve its optimum effect. Failure to adhere to this warning could result in serious personal injury or death.

**WARNING:** Repairs to the steering wheel, steering column, seats, airbags and seatbelts must be carried out by an authorized dealer. Failure to adhere to this warning could result in serious personal injury or death.

**WARNING:** Keep the areas in front of the airbags free from obstruction. Do not affix anything to or over the airbag covers. Objects could become projectiles during airbag deployment. Failure to follow this instruction could result in personal injury or death.

**WARNING:** Do not poke sharp objects into areas where airbags are fitted. This could damage and adversely affect deployment of the airbags. Failure to follow this instruction could result in personal injury or death.

**WARNING:** Do not use accessory seat covers. The use of accessory seat covers may prevent the deployment of the side airbags and increase the risk of injury in an accident.

**Note:** A loud bang sounds and there is a cloud of harmless powdery residue if an airbag deploys. This is normal.

**Note:** Only wipe airbag covers with a damp cloth.

## DRIVER AIRBAG

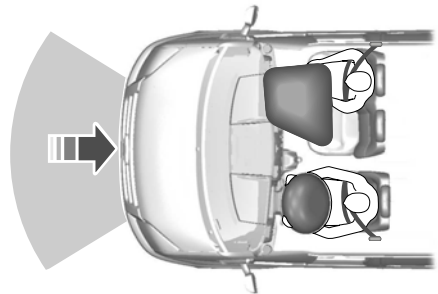

E268726

# Supplementary Restraints System

The airbag is designed to deploy during a significant frontal or near-frontal crash. The airbag inflates within a few thousandths of a second cushioning forward body movement and deflates on contact with the occupant. The airbag is not designed to deploy during a minor frontal crash, rear crash, side crash or a vehicle rollover.

## PASSENGER AIRBAG

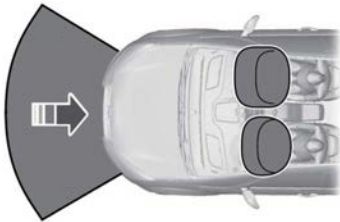

E151127

The airbag is designed to deploy during a significant frontal or near-frontal crash. The airbag inflates within a few thousandths of a second cushioning forward body movement and deflates on contact with the occupant. The airbag is not designed to deploy during a minor frontal crash, rear crash, side crash or a vehicle rollover.

## SWITCHING THE PASSENGER AIRBAG ON AND OFF



E71313

The switch is on the end of the instrument panel on the passenger side of your vehicle. The passenger airbag deactivation indicator is near the climate controls.

## Switching the Passenger Airbag Off

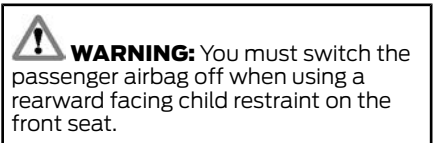

1. Insert the key blade into the switch.

# Supplementary Restraints System



E249662

2. Turn the key to the **OFF** position.
3. When you switch the ignition on, check that the passenger airbag deactivation **OFF** indicator illuminates. If it does not illuminate when you switch the ignition on, this indicates a malfunction. Have your vehicle checked as soon as possible.

## Switching the Passenger Airbag On

**WARNING:** You must switch the passenger airbag on following the removal of the child restraint.

1. Insert the key blade into the switch.



E249648

2. Turn the key to the **ON** position.

3. When you switch the ignition on, check that the passenger airbag deactivation **ON** indicator illuminates. If it does not illuminate when you switch the ignition on, this indicates a malfunction. Have your vehicle checked as soon as possible.

## SIDE AIRBAGS

**WARNING:** Do not place objects or mount equipment on or near the headliner at the siderail that may come into contact with a deploying curtain airbag. Failure to follow these instructions may increase the risk of personal injury in the event of a crash.

**WARNING:** Do not lean your head on the door. The side airbag could injure you as it deploys from the side of the seatback.

**WARNING:** Do not use accessory seat covers. The use of accessory seat covers may prevent the deployment of the side airbags and increase the risk of injury in an accident.

**WARNING:** Do not attempt to service, repair, or modify the supplementary restraint system or associated components. Failure to follow this instruction could result in personal injury or death.

**WARNING:** If a supplementary restraint system component has deployed, it will not function again. Have the system and associated components inspected as soon as possible. Failure to follow this instruction could result in personal injury or death.

# Supplementary Restraints System



E72658

The side airbags are on the outermost side of each front seat backrest. There is a label attached to the side of each backrest to indicate this.



E152533

The side airbags are designed to inflate between the door panel and the occupant to enhance the protection in certain crashes.

The airbag is designed to deploy during a significant lateral crash. It might also deploy during a significant frontal crash. The airbag is not designed to deploy during a minor lateral or frontal crash, rear crash or a vehicle rollover.

## SIDE CURTAIN AIRBAGS

 **WARNING:** Do not place objects or mount equipment on or near the headliner at the siderail that may come into contact with a deploying curtain airbag. Failure to follow these instructions may increase the risk of personal injury in the event of a crash.

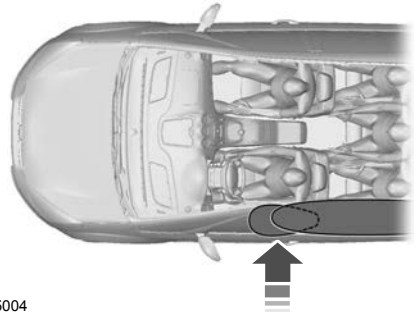

E75004

The airbags are above the front and rear side windows.

The airbag is designed to deploy during a significant lateral or frontal angled crash. The airbag is not designed to deploy during a minor lateral and frontal crash, rear crash or a vehicle rollover.

# Automatic Crash Notification System

## EMERGENCY ASSISTANCE



**WARNING:** Unless the Emergency Assistance setting is on prior to a collision, the system does not attempt to place an emergency call. This could delay the response time, increasing the risk of serious injury or death.



**WARNING:** For this feature to work, your mobile phone must be Bluetooth-enabled and compatible with the system.



**WARNING:** Always place your phone in a secure location in your vehicle so it does not become a projectile or get damaged in a crash. Failure to do so may cause serious injury to someone or damage the phone which could prevent Emergency Assistance from working properly.

**Note:** *Not all accidents activate the system. If an accident does trigger the system, it initiates a call to the emergency services. Do not wait for the system to initiate a call if you are able to do so. Call emergency services immediately to avoid a delayed response time. If you do not hear the system within five seconds of the accident, the system could be non-functional.*

If an accident results in an attempt to deploy an airbag, excluding knee airbags and rear inflatable seatbelts, or to shut off the fuel pump, the system initiates a call to the emergency services.

**Note:** *Before setting the feature on, please read the important notice about the Emergency Assistance feature and the Emergency Assistance privacy notice later in this section for important information.*

**Note:** *When you switch Emergency Assistance on or off, the settings apply to all paired mobile phones. If you switch Emergency Assistance off and a previously paired phone connects when you switch the ignition on, either a voice message plays, a display message or icon is shown or both.*

**Note:** *Every mobile phone operates differently. While Emergency Assistance works with most mobile phones, some mobile phones may experience difficulties using this feature.*

**Note:** *In the case of an emergency, the system, as a means of communication aid, can help you contact specific rescue departments of public emergency services. The system does not deploy the rescue operations. The local public emergency service deploys specific rescue operations according to the actual situation.*

To make sure that Emergency Assistance works correctly:

- The system must have power and be working correctly at the time of the crash and during feature activation and use.
- You must switch on the feature before a crash.
- You must have a cell phone connected to the system.
- In certain countries, it may be necessary to have a valid and registered SIM card with credit in order to place and maintain an emergency call.
- A connected cell phone must have the ability to make and maintain an outgoing call at the time of the crash.
- A connected cell phone must have adequate network coverage, battery power and signal strength.
- Your vehicle must have battery power.

# Automatic Crash Notification System

---

**Note:** *This feature only works in a country where Emergency Assistance can call the local emergency services. For additional information, please refer to the local Ford website.*

## In the Event of a Crash

Before making a call:

- If you do not cancel the call, an introductory message plays for the emergency operator. After this message, there is hands-free communication between your vehicle's occupants and the operator.
- The system provides a short window of time (approximately 10 seconds) to cancel the call. If you do not cancel the call, the system initiates a call to the emergency services.
- The system plays a message letting you know when it attempts to make an emergency call. You can cancel the call by selecting the relevant button or by pressing the end call button on the steering wheel.

**Note:** *Not every crash deploys an airbag or triggers the fuel pump shut off, which may turn on Emergency Assistance. However, if Emergency Assistance is triggered, the system tries to contact the emergency services. If a connected cell phone sustains damage or loses connection to the system, it searches for and tries to connect to any available previously paired cell phone and initiates a call to the emergency services.*

During a call:

- Emergency Assistance uses your vehicle GPS or cellular network information when available to determine the most appropriate language to use. It alerts the emergency operator of the crash and delivers the introductory message. This may include your vehicle GPS coordinates.
- The language the system uses to interact with the occupants of your vehicle may differ from the language used to deliver information to the emergency operator.
- After the delivery of the introductory message the voice line opens so that you can speak hands-free with the emergency operator.
- When the line is connected, you must be prepared to provide your name, phone number and location information immediately.

**Note:** *While the system provides information to the emergency operator, the system plays a message letting you know it is sending important information. It then lets you know when the line is open to start hands-free communication.*

**Note:** *During an Emergency Assistance call, an emergency priority screen appears which contains vehicle GPS coordinates when available.*

**Note:** *It is possible that GPS location information is not available at the time of the crash; in this case, Emergency Assistance will still attempt to place an emergency call.*

**Note:** *It is possible that the emergency services will not receive the GPS coordinates; in this case, hands-free communication with an emergency operator is available.*

# Automatic Crash Notification System

---

**Note:** *The emergency operator may also receive information from the cellular network such as cell phone number, cell phone location and cell phone carrier name independent from Emergency Assistance.*

## **Emergency Assistance may not work if:**

- Your cell phone or Emergency Assistance hardware sustains damage in the crash.
- The vehicle battery or the system has no power.
- A crash ejects your cell phone from your vehicle.
- You do not have a valid and registered SIM card with credit in your cell phone.
- You are in a country where Emergency Assistance cannot call the local emergency services. For additional information, please refer to the local Ford website.

## **Important Information About Emergency Assistance**

Emergency Assistance does not currently call emergency services in the following countries:

- Albania.
- Armenia.
- Azerbaijan.
- Belarus.
- Bosnia and Herzegovina.
- Georgia.
- Macedonia.
- Moldova.
- Netherlands.
- Russia.
- Ukraine.

## **Emergency Assistance Privacy Notice**

When you switch on Emergency Assistance, it may disclose to emergency services that your vehicle has been in a crash involving the deployment of an airbag or activation of the fuel pump shut off. This feature has the capability to disclose your location information to the emergency operator or other details about your vehicle or crash to provide the most appropriate emergency services.

If you do not want to disclose this information, do not switch on the feature.

## PRINCIPLE OF OPERATION

The system is designed to promote good driving behaviors using keys that you have programmed with some restricted settings.

## MYKEY SETTINGS

### Non-Configurable Settings

#### Seatbelt Reminder

The audio system mutes when the seatbelt reminder turns on. The seatbelt reminder cannot be switched off with a MyKey.

#### Early Low Fuel

The low fuel level indicator turns on earlier.

#### Driving and Parking Aids

Parking aids, blind spot information system and cross traffic alert turn on when you start the engine and cannot be switched off with a MyKey.

Pre-collision assist and lane keeping alert turn on when you start the engine, but can be switched off with a MyKey.

A new destination in the navigation system can only be set using voice commands, when using a MyKey and your vehicle is moving.

### Configurable Settings

You can configure the following settings after creating a MyKey. See **Creating a MyKey** (page 38).

### Speed Limit

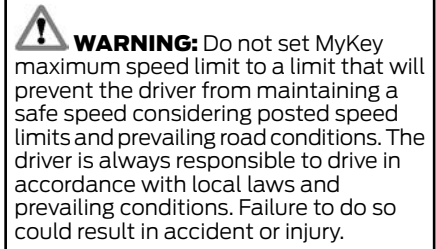

You can set a speed limit for your vehicle. Warning messages appear in the information display and a tone sounds if your vehicle reaches the set speed. You cannot override the set speed when using a MyKey.

#### Speed Reminder

You can set a speed reminder for your vehicle. Warning messages appear in the information display and a tone sounds if your vehicle exceeds the set speed.

#### Audio System Volume Limit

The audio system maximum volume is reduced. A message appears in the information display if you attempt to exceed the volume limit. Automatic volume control turns off.

#### Emergency Assistance

If you set emergency assistance to be always on, it cannot be switched off with a MyKey.

#### Do Not Disturb

If you set do not disturb to be always on, it cannot be switched off with a MyKey.

#### Traction Control

If you set traction control to be always on, it cannot be switched off with a MyKey.

## CREATING A MYKEY - VEHICLES WITHOUT: PUSH BUTTON START

Switch the ignition on using an admin key.

**To create a MyKey, use the information display controls on the steering wheel to select the following:**

Menu Item	Action
Settings	Press the menu button.
MyKey	Press the <b>OK</b> button.
Create MyKey	Press and hold the <b>OK</b> button until a confirmation message appears in the information display.
	Switch the ignition off.

**Note:** *We recommend that you label this key.*

### MyKey Information Messages

Message	Description
Key is already a MyKey	Displays when trying to create a MyKey with a key already designated as a MyKey.
Hold OK to create MyKey	Displays when creating a MyKey.
Creation completed	Displays to confirm that a MyKey has been created.
Key restricted at next start. Label this key	Displays to confirm that the key is restricted after you switch the ignition off.
MyKey not created	Displays if the system fails to create a MyKey.

2. Switch the ignition on.

## CREATING A MYKEY - VEHICLES WITH: PUSH BUTTON START

1. Place an admin key in the backup position. See **Passive Key Backup Position** (page 48).

# MyKey™

**To create a MyKey, use the information display controls on the steering wheel to select the following:**

Menu Item	Action
Settings	Press the menu button.
MyKey	Press the <b>OK</b> button.
Create MyKey	Press and hold the <b>OK</b> button until a confirmation message appears in the information display.
	Switch the ignition off.

**Note:** *We recommend that you label this key.*

## MyKey Information Messages

Message	Description
Place key in backup location	Displays when trying to create a MyKey and the key is not placed in the backup position. See <b>Passive Key Backup Position</b> (page 48).
Key is already a MyKey	Displays when trying to create a MyKey with a key already designated as a MyKey.
Hold OK to create MyKey	Displays when creating a MyKey.
Creation completed	Displays to confirm that a MyKey has been created.
Key restricted at next start. Label this key	Displays to confirm that the key is restricted after you switch the ignition off.
MyKey not created	Displays if the system fails to create a MyKey.

Switch the ignition on using an admin key.

## PROGRAMMING A MYKEY

You can only program MyKeys to the same settings.

# MyKey™

---

**To program a MyKey, use the information display controls on the steering wheel to select the following:**

Menu Item	Action
Settings	Press the menu button.
MyKey	Press the <b>OK</b> button. Choose a setting and press the <b>OK</b> button. Configure the setting. Switch the ignition off.

## CLEARING ALL MYKEYS

restrictions and return all MyKeys to their original admin key status.

When you clear all MyKeys, you remove all

Switch the ignition on using an admin key.

**To clear all MyKeys, use the information display controls on the steering wheel to select the following:**

Menu Item	Action
Settings	Press the menu button.
MyKey	Press the <b>OK</b> button.
Clear MyKeys	Press and hold the <b>OK</b> button until a confirmation message appears in the information display.

## MyKey Information Messages

Message	Description
Hold OK to clear MyKeys	Displays when clearing all MyKeys.
All MyKeys cleared	Displays to confirm that all MyKeys have been cleared.

## CHECKING MYKEY SYSTEM STATUS

Switch the ignition on.

**To find information about the distance traveled using a MyKey and also the number of admin keys and MyKeys created for your vehicle, use the information display controls on the steering wheel to select the following:**

Menu Item	Action
Settings	Press the menu button.
MyKey	Press the <b>OK</b> button.
MyKey info	Press the <b>OK</b> button.

## USING MYKEY WITH REMOTE START SYSTEMS

The system is not compatible with non-Ford remote start systems.

## MYKEY – TROUBLESHOOTING - VEHICLES WITHOUT: PUSH BUTTON START

### What is an admin key?

- An admin key is a key that has not been created as a MyKey. See **Creating a MyKey** (page 38).

### Why can I not create a MyKey?

- The key used to switch the ignition on is not an admin key.
- The key used to switch the ignition on is the only admin key. There always has to be at least one admin key.

### Why can I not program a MyKey?

- The key used to switch the ignition on is not an admin key.
- No MyKeys are created. See **Creating a MyKey** (page 38).

### Why can I not clear the MyKeys?

- The key used to switch the ignition on is not an admin key.
- No MyKeys are created. See **Creating a MyKey** (page 38).

### Why does the MyKey distance not accumulate?

- The key used to start the engine is an admin key.
- No MyKeys are created. See **Creating a MyKey** (page 38).
- The MyKeys have been cleared.

## MYKEY – TROUBLESHOOTING - VEHICLES WITH: PUSH BUTTON START

### What is an admin key?

- An admin key is a key that has not been created as a MyKey. See **Creating a MyKey** (page 38).

### Why can I not create a MyKey?

- The admin key is not placed in the backup position. See **Passive Key Backup Position** (page 48).
- The key used to switch the ignition on is not an admin key.
- The key used to switch the ignition on is the only admin key. There always has to be at least one admin key.
- The last MyKey was created without switching the ignition off.

### Why can I not program a MyKey?

- The admin key is not inside your vehicle.
- The key used to switch the ignition on is not an admin key.
- No MyKeys are created. See **Creating a MyKey** (page 38).

### Why can I not clear the MyKeys?

- The admin key is not inside your vehicle.
- The key used to switch the ignition on is not an admin key.
- No MyKeys are created. See **Creating a MyKey** (page 38).

## **Why does the MyKey distance not accumulate?**

- The key used to start the engine is an admin key.
- An admin key and a MyKey are inside your vehicle.
- No MyKeys are created. See **Creating a MyKey** (page 38).
- The MyKeys have been cleared.

## **Why can I not start the engine with a MyKey?**

- An admin key and a MyKey are inside your vehicle.

# Keys and Remote Controls

## GENERAL INFORMATION ON RADIO FREQUENCIES

**Note:** *Changes or modifications not expressly approved by the party responsible for compliance could void the user's authority to operate the equipment.*

The typical operating range for your transmitter is approximately 10 m (33 ft).

A decrease in operating range could be caused by:

- weather conditions
- nearby radio towers
- structures around your vehicle
- other vehicles parked next to your vehicle.

The radio frequency used by your remote control can also be used by other radio transmitters, for example amateur radios, medical equipment, wireless headphones, wireless remote controls, cell phones, battery chargers and alarm systems. If the frequencies are jammed, you will not be able to use your remote control. You can lock and unlock the doors with the key.

**Note:** *Make sure your vehicle is locked before leaving it unattended.*

**Note:** *If you are in range, the remote control will operate if you press any button unintentionally.*

**Note:** *The remote control contains sensitive electrical components. Exposure to moisture or impact may cause permanent damage.*

## REMOTE CONTROL-VEHICLES WITH: KEYLESS ENTRY AND PUSH BUTTON START



E272922

The key operates the power locks. The key must be in your vehicle to use the push button start.

**Note:** *You may not be able to shift out of park (P) unless the key is inside your vehicle.*

### Removable Key Blade

The key also contains a removable key blade that you can use to unlock your vehicle.

# Keys and Remote Controls



E272923

Press the release button and pull the key blade out.



E151795

**Note:** Your vehicle keys came with a security label that provides important key cut information. Keep the label in a safe place for future reference.

## Replacing the Battery

**Note:** Refer to local regulations when disposing of transmitter batteries.

**Note:** Do not wipe off any grease on the battery terminals or on the back surface of the circuit board.

**Note:** Replacing the battery does not erase the programmed key from your vehicle. The transmitter should operate normally.

A message appears in the information display when the remote control battery is low. See **Information Messages** (page 82).

The remote control uses one coin-type three-volt lithium battery CR2450 or equivalent.



E272923

1. Press the release button and pull the key blade out.

## Keys and Remote Controls



E218401

2. Twist a thin coin under the tab hidden behind the key blade head to remove the battery cover.



E218402

3. Insert a suitable tool, for example a screwdriver, in the position shown and carefully remove the battery.
4. Install a new battery with the + facing up.
5. Reinstall the battery cover and the key blade.

### Locating Your Vehicle



Press the button twice within three seconds. The horn sounds and the direction indicators flash. We recommend you use this method to locate your vehicle, rather than using the panic alarm.

### REMOTE CONTROL-VEHICLES WITH: REMOTE FLIP KEY

Use the key blade to start your vehicle and unlock or lock the driver door from outside your vehicle. The buttons on the key operate the remote control function.

# Keys and Remote Controls



E272916

Press the button to release the key blade. Press and hold the button to fold the key blade back in when not in use.



E151795

**Note:** Your vehicle keys came with a security label that provides important key cut information. Keep the label in a safe place for future reference.

## Replacing the Battery

**Note:** Refer to local regulations when disposing of transmitter batteries.

**Note:** Do not wipe off any grease on the battery terminals or on the back surface of the circuit board.

**Note:** Replacing the battery does not erase the programmed key from your vehicle. The transmitter should operate normally.

A message appears in the information display when the remote control battery is low. See **Information Messages** (page 82).

The remote control uses one coin-type three-volt lithium battery CR2032 or equivalent.

Press the button to release the key blade before beginning the procedure.



E272917

1. Insert a suitable tool, for example a screwdriver, in the position shown and gently press the clip.
2. Press the clip down to release the battery cover.

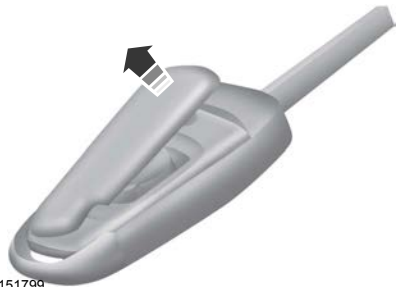

E151799

3. Carefully remove the battery cover.

# Keys and Remote Controls



E151800

**Note:** Do not touch the battery contacts or the printed circuit board with the screwdriver.

4. Insert the screwdriver in the position shown to release the battery.



E151801

5. Remove the battery.
6. Install a new battery with the **+** facing upward.
7. Reinstall the battery cover.

## Locating Your Vehicle



Press the button twice within three seconds. The horn sounds and the direction indicators flash. We recommend you use this method to locate your vehicle, rather than using the panic alarm.

## REPLACING A LOST KEY OR REMOTE CONTROL

You can purchase replacement keys or remote controls from an authorized dealer. Authorized dealers can program remote controls for your vehicle. See **Remote Control** (page 44).

To re-program the passive anti-theft system see an authorized dealer.

## PASSIVE KEY BACKUP POSITION

1. Remove the key blade. See **Remote Control** (page 44).

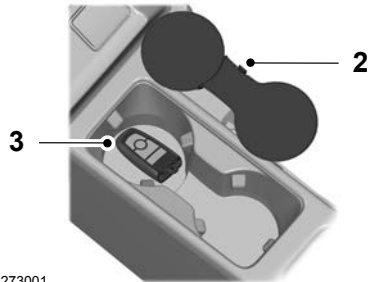

E273001

2. Remove the rubber mat.
3. Place the passive key in the position shown, with the buttons facing upward and the unlock button facing the front of your vehicle.

# Doors and Locks

## LOCKING AND UNLOCKING

**Note:** Check your vehicle is locked before leaving it unattended.

**Note:** Do not leave your keys in your vehicle.

### Locking

#### Locking with the Key

Turn the top of the key toward the front of your vehicle.

#### Locking with the Remote Control



Press the button.

**Note:** You can lock the driver door with the key. Use the key when the remote control is not functioning.

### Double Locking



**WARNING:** Do not use double locking when passengers or animals are inside your vehicle. The doors cannot be unlocked or opened from the inside when double locked.

Double locking is a theft protection feature that prevents someone from opening the doors from the inside.

**Note:** If you double lock your vehicle while inside, switch the ignition on to return the door locks to a single locked state.

#### Double Locking with the Key

Turn the key to the lock position twice within three seconds.

#### Double Locking with the Remote Control



Press the button twice within three seconds.

## Unlocking

### Unlocking with the Key

Turn the top of the key toward the rear of your vehicle.

### Unlocking with the Remote Control



Press the button.

**Note:** You can unlock the driver door with the key. Use the key when the remote control is not functioning.

**Note:** When you lock your vehicle for several weeks, the remote control will be switched off. Your vehicle must be unlocked and the engine started using the key. Unlocking and starting your vehicle once will enable the remote control.

### Unlocking the Liftgate



Press the button.

**Note:** The liftgate does not automatically open.

**Note:** The liftgate unlocks if you unlock all doors.

## Reprogramming the Unlocking Function

When you press the unlock button all doors unlock.

You can reprogram the unlocking function so that only the driver door unlocks.

1. Switch the ignition off.
2. Press and hold both the lock and unlock buttons on the remote control until the direction indicators flash twice to confirm the change.

To return to the original unlocking function, repeat the process.

# Doors and Locks

## Locking and Unlocking Confirmation

When you lock your vehicle, the direction indicators flash to confirm your vehicle has locked.

When you unlock your vehicle, the direction indicators flash to confirm your vehicle has unlocked.

## Locking and Unlocking the Doors From Inside

The power door lock control is on the driver door.



Press the button to lock and unlock all the doors. The lamp illuminates with the doors locked.

## Opening the Sliding Door (If Equipped)



E164229

## Opening the Double Rear Doors (If Equipped)

**Note:** If there is a ladder fitted to the rear cargo door, do not open the door fully if the side-loading door is open.



E148805

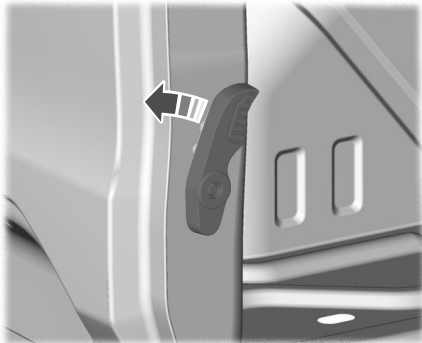

E148806

# Doors and Locks

## Fully Opening the Double Rear Doors

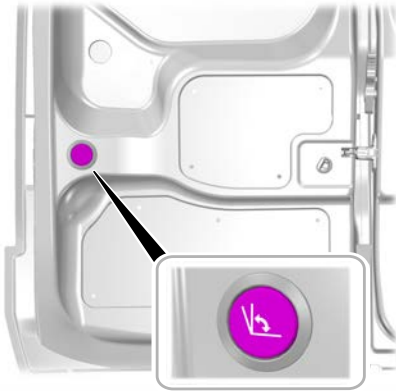

E289574

Press the button to fully open the double rear doors.

## Locking the Doors Individually With the Key

**Note:** If the central locking function fails to operate, the doors can be individually locked using the key in the position shown.

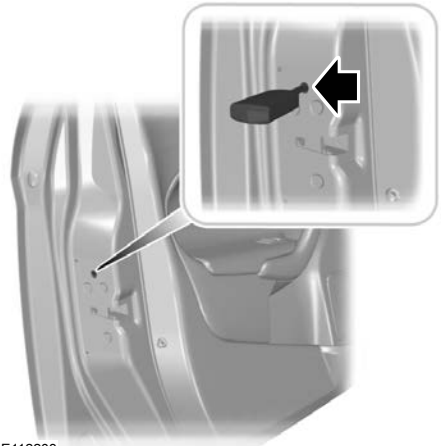

E112203

### Left-hand Side

Turn clockwise to lock.

### Right-hand Side

Turn counterclockwise to lock.

### Rear Emergency Exit (If Equipped)

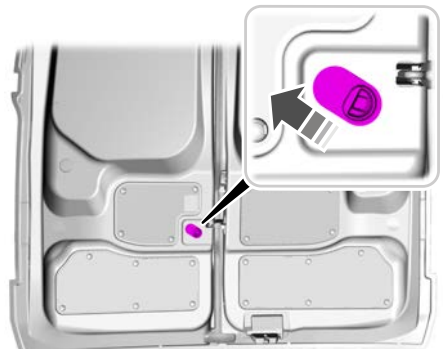

E180300

Pull the interior handle up to open the door in an emergency.

# Doors and Locks

---

## **Automatic Locking (If Equipped)**

Your vehicle has the capability for the doors to lock automatically when you exceed 5 mph (8 km/h). You can turn this function on using the information display. See **Information Displays** (page 80). If you have turned this function on, either use the interior door unlock button or switch the ignition off and use the key or remote control to unlock the rear or sliding door.

## **Automatic Re-Locking**

The doors will re-lock automatically if you do not open a door within 45 seconds of unlocking the doors with the remote control. The door locks and the alarm will return to their previous state.

## **Automatic Unlocking**

You can turn this function on using the information display. See **Information Displays** (page 80). When enabled, the automatic unlocking feature will unlock all doors within 10 minutes of the end of a drive cycle, when the driver door is opened and the ignition is off.

## **One-Stage Unlocking**

You can turn this function on using the information display. See **Information Displays** (page 80).

When you use this feature, you will unlock all doors including the liftgate and the sliding door.

You will unlock all of the doors when you:

- Turn the key in the door lock.
- Pull either interior handle (except if you have double locked the doors).
- Press the unlock button on the remote control once.
- Press the interior unlock button once.

**Note:** *When you have double locked your vehicle, the interior unlock button will only work for a period of 11 seconds.*

## **Two-Stage Unlocking**

You will unlock the front doors when you:

- Turn the key in the door lock.
- Press the unlock button on the remote control once.

**Note:** *When you have double locked your vehicle, the interior unlock button will only work for a period of 11 seconds.*

You will unlock all doors including the liftgate and the sliding door when you:

- Turn the key in the door lock to the unlock position twice within three seconds.
- Press the unlock button on the remote control twice within three seconds.
- Press the interior unlock button twice.

**Note:** *When you have double locked your vehicle, the interior unlock button will only work for a period of 11 seconds.*

## **Configurable Unlocking**

Configurable unlocking is set at the time of vehicle purchase. It allows you to select which doors unlock when you press the unlock button or the luggage compartment unlock button on your remote control once or twice. You cannot turn this feature back on if you have had it turned off. See an authorized dealer for further information.

# Doors and Locks

## SLIDING DOOR



E145826

When the rear doors are fully open, make sure that you do not step on the cable or mechanism at the base of the door aperture. This could damage the sliding door and its components.

## KEYLESS ENTRY

### General Information

The system will not function if:

- The vehicle battery has no charge.
- The passive key battery has no charge.
- The passive key frequencies are jammed.
- The door handle is not clean.

**Note:** *If the system does not function, you will need to use the key blade to lock and unlock your vehicle.*

The system allows you to operate your vehicle without the use of a key or remote control.

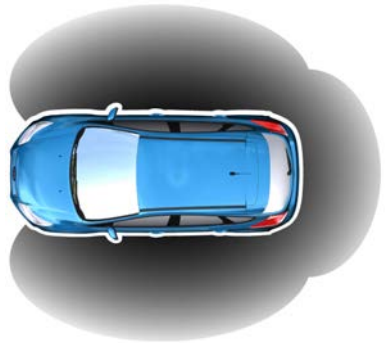

E78276

Passive locking and unlocking requires a valid passive key to be located within one of the three external detection ranges. These are located approximately 1.5 m (5 ft) from the front door handles and the liftgate.

**Note:** *The system may not function if the passive key is close to metal objects or electronic devices, for example keys or a cell phone.*

### Passive Key

Your vehicle can be locked and unlocked using the passive key. You can also use the passive key as a remote control to lock and unlock your vehicle. See **Locking and Unlocking** (page 49).

### Locking Your Vehicle

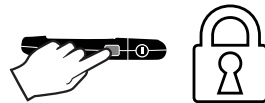

E248556

The locking sensors are on the front door handles.

Touch a locking sensor once to lock your vehicle and arm the alarm.

# Doors and Locks

For vehicles with double locking, touch a locking sensor twice within three seconds to double lock your vehicle and arm the alarm.

**Note:** When locking your vehicle, do not grip the door handle.

**Note:** Your vehicle remains locked for approximately one second. When the delay period is over, you can open the doors again, provided the passive key is within the respective detection range.

**Note:** Your vehicle does not automatically lock. If you do not touch a locking sensor your vehicle remains unlocked.

Two short flashes of the direction indicators confirms that all the doors and the liftgate have been locked and that the alarm has been armed.

## At the Liftgate

The liftgate cannot be closed and will reopen if the passive key is located inside the luggage compartment with the doors locked.

**Note:** If a second valid passive key is located within the liftgate detection range, the liftgate can be closed.

## Unlocking Your Vehicle



E248555

Pull a front exterior door handle to unlock and open the door. Do not touch the lock sensor on the front of the handle.

One long flash of the direction indicators confirms that all the doors and the liftgate have been unlocked and that the alarm has been disarmed.

**Note:** A valid passive key must be located within the detection range of that door.

## Unlocking Only the Driver's Door

You can program the system so that only the driver door is unlocked. See **Locking and Unlocking** (page 49).

If you program the unlocking function so that only the driver door unlocks, the following occurs:

- If the driver's door is the first door which is opened, the other doors will remain locked. All the other doors can be unlocked from inside your vehicle by pressing the unlock button located on the driver's and front passenger's door. You can unlock individual doors by pulling the interior door handles on those doors.
- If the front passenger's door is the first door which is opened, all the doors and the liftgate will be unlocked.

## Disabled Keys

Any keys left inside your vehicle interior when it is locked will be disabled.

You cannot use a disabled key to switch the ignition on or start the engine.

You must enable all passive keys again in order to use them. To enable all your passive keys, unlock your vehicle using a passive key that has not been disabled or the remote control unlocking function. All passive keys will then be enabled if you switch the ignition on or you start your vehicle with a valid key.

**Note:** You can still start your vehicle when the passive key is in the back-up position. See **Push Button Ignition Switch** (page 123).

## Doors and Locks

---

### Locking and Unlocking the Doors with the Key Blade



E272923

Push the release button and pull the key blade out.

**Note:** Only the driver door handle has a lock cylinder.

# Liftgate

## MANUAL LIFTGATE



**WARNING:** It is extremely dangerous to ride in a cargo area, inside or outside of a vehicle. In a crash, people riding in these areas are more likely to be seriously injured or killed. Do not allow people to ride in any area of your vehicle that is not equipped with seats and seatbelts. Make sure everyone in your vehicle is in a seat and properly using a seatbelt. Failure to follow this warning could result in serious personal injury or death.



**WARNING:** Make sure to close and latch the liftgate to prevent drawing exhaust fumes into your vehicle. This will also prevent passengers and cargo from falling out. If you must drive with the liftgate open, keep the vents or windows open so outside air comes into your vehicle. Failure to follow this warning could result in serious personal injury.

**Note:** Be careful when opening or closing the liftgate in a garage or other enclosed area to avoid damaging the liftgate.

**Note:** Do not hang anything, for example a bike rack, from the glass or liftgate. This could damage the liftgate and its components.

## Unlocking the Liftgate



Press the button on the remote control.

## Opening the Liftgate

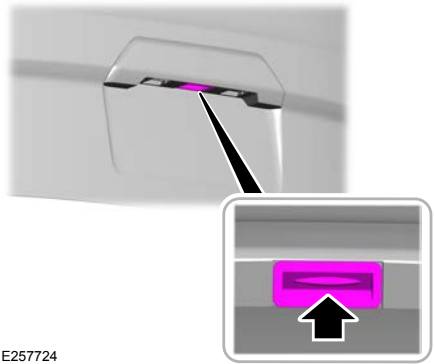

E257724

Press the exterior release button hidden above the license plate.

## Closing the Liftgate

Pull the strap inside the liftgate to help with closing.

# Security

## PASSIVE ANTI-THEFT SYSTEM

### Principle of Operation

The system prevents someone from starting the engine with an incorrectly coded key.

**Note:** *Always take your keys and lock all doors when leaving your vehicle.*

### Coded Keys

If you lose a key, you can obtain a replacement from an authorized dealer. If possible, provide them with the key number from the tag provided with the original keys. You can also obtain extra keys from an authorized dealer.

**Note:** *Have all of your remaining keys erased and recoded if you lose a key. Have replacement keys coded together with recoding your remaining keys. Ask an authorized dealer for more information.*

**Note:** *Metallic objects, electronic devices or a second coded key on the same key chain may result in vehicle starting problems, especially if they are too close to the key when starting your vehicle.*

### Arming the Engine Immobilizer

The engine immobilizer arms after a short period of time when you switch the ignition off.

### Disarming the Engine Immobilizer

The engine immobilizer disarms when you switch the ignition on with a correctly coded key.

If you are unable to start your vehicle with a correctly coded key, have your vehicle checked by an authorized dealer.

## ANTI-THEFT ALARM

### Alarm System (If Equipped)

Your vehicle may have one of the following alarm systems:

- Category one alarm with interior sensors and battery back-up sounder.
- Perimeter alarm.

### Perimeter Alarm

The perimeter alarm is a deterrent against unauthorized access to your vehicle through the doors, luggage compartment and the hood.

### Interior Sensors

The interior sensors are in the overhead console.

When you lock your vehicle and arm the alarm, the sensors are designed to detect any movement inside your vehicle.

**Note:** *Do not cover the interior sensors.*

### Inclination Sensors

When you lock your vehicle and arm the alarm, the sensors are designed to detect an attempt to raise your vehicle, for example to remove a wheel or to tow it away.

### Battery Back-up Sounder

The battery back-up sounder is an extra alarm system that sounds a siren when the alarm is triggered. When you lock your vehicle the system is armed. The sounder has its own battery and will sound an alarm siren even if someone disconnects your vehicle battery or the battery back-up sounder itself.

### Triggering the Alarm

Once armed, the alarm is triggered in any of the following ways:

# Security

---

- If someone opens a door, the liftgate or the hood without a valid key or remote control.
- If someone removes the navigation system or certain types of audio system.
- If you switch the ignition on without a valid key.
- If the interior sensors detect movement within your vehicle.
- On vehicles with a battery back-up sounder, if someone disconnects your vehicle battery or the battery back-up sounder itself.

If the alarm is triggered, the alarm horn will sound for 30 seconds and the hazard warning flashers will flash for five minutes.

Any further attempts to carry out one of the above will trigger the alarm again.

## Full Guard and Reduced Guard

### Full Guard

Full guard is the standard setting.

In full guard, the interior sensors are on when you arm the alarm.

**Note:** *Do not arm the alarm with full guard if passengers, animals or other moving objects are inside your vehicle.*

### Reduced Guard

In reduced guard, the interior sensors are off when you arm the alarm.

## Selecting Full or Reduced Guard

You can select full or reduced guard using the information display. See **General Information** (page 80).

### Ask on Exit

If you switch ask on exit on, you can choose which level of guard you require after you switch the ignition off.

## Arming the Alarm

To arm the alarm, lock your vehicle. See **Doors and Locks** (page 49).

## Disarming the Alarm

### Perimeter Alarm

Disarm and silence the alarm by unlocking the doors with the key and switching the ignition on with a correctly coded key or unlocking the doors with the remote control.

### Category One Alarm

Disarm and silence the alarm by unlocking the doors with the key and switching the ignition on with a correctly coded key within 12 seconds or unlocking the doors with the remote control.

# Steering Wheel

## ADJUSTING THE STEERING WHEEL



**WARNING:** Do not adjust the steering wheel when your vehicle is moving.

**Note:** Make sure that you are sitting in the correct position. See **Sitting in the Correct Position** (page 105).



E95178

1. Unlock the steering column.
2. Adjust the steering wheel to the desired position.



E95179

3. Lock the steering column.

# Wipers and Washers

## WINDSHIELD WIPERS

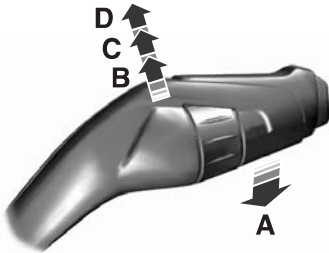

E197525

- A Single wipe.
- B Intermittent wipe.
- C Normal wipe.
- D High-speed wipe.

**Note:** Fully defrost the windshield before you switch the windshield wipers on.

**Note:** Make sure that you switch the windshield wipers off before entering a car wash.

**Note:** If streaks or smears appear on the windshield, clean the windshield and the wiper blades. See **Checking the Wiper Blades** (page 249). If that does not resolve the issue, install new wiper blades. See **Changing the Front Wiper Blades** (page 249).

**Note:** Do not operate the wipers on a dry windshield. This may scratch the glass or damage the wiper blades. Always use the windshield washers before wiping a dry windshield.

## Intermittent Wipe

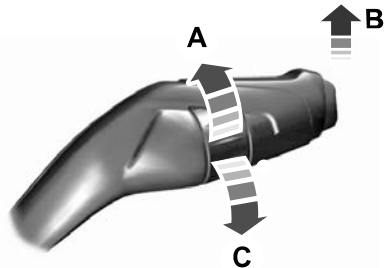

E197526

- A Short wipe interval.
- B Intermittent wipe.
- C Long wipe interval.

Use the rotary control to adjust the intermittent wipe interval.

**Note:** When your vehicle speed increases, the interval between intermittent wipes may decrease.

## AUTOWIPERS

Autowipers uses a rain sensor in the area around the interior mirror. The wipers operate when the rain sensor detects water on the windshield in front of it. The rain sensor continues to monitor the amount of water and adjusts the speed of the wipers.

**Note:** The wipers remain in a slightly raised position during operation and only return to the park position a short time after the rain sensor detects no water on the windshield.

You can switch autowipers on or off in the information display.

**Note:** If you switch autowipers off in the information display, the windshield wipers operate in intermittent mode.

# Wipers and Washers

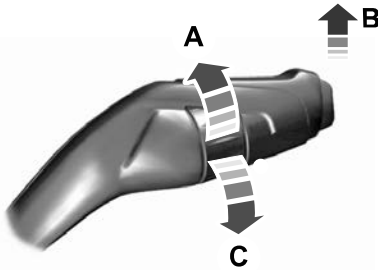

E197526

- A High sensitivity.
- B Autowipers on.
- C Low sensitivity.

Move the wiper lever upward to the first position to switch autowipers on.

Use the rotary control to adjust the sensitivity of the autowipers. When you select low sensitivity, the wipers operate when the sensor detects a large amount of water on the windshield. When you select high sensitivity, the wipers operate when the sensor detects a small amount of water on the windshield.

**Note:** Keep the outside of the windshield clean. The rain sensor is very sensitive and the wipers may operate if dirt, mist or insects hit the windshield.

## Settings

**To switch autowipers on or off, use the information display controls on the steering wheel to select the following:**

Menu Item	Action
Settings	Press the menu button.
Vehicle settings	Press the <b>OK</b> button.
Wipers	Press the <b>OK</b> button.
Rain sensing	Press the <b>OK</b> button.

If you leave autowipers on, it may not operate when you switch the ignition on during freezing temperatures. This is because the system has deactivated the rain sensor to prevent damage to the windshield wipers. Defrost the windshield before reactivating the rain sensor. You can reactivate the rain sensor by moving the rotary control or switching autowipers off and on.

**Note:** Fully defrost the windshield before you switch the windshield wipers on.

**Note:** Make sure that you switch the windshield wipers off before entering a car wash.

Wet or winter weather conditions could cause unexpected wiping or smearing.

To keep the windshield clear:

- Lower the sensitivity of the autowipers to reduce the amount of smearing on the windshield.
- Switch autowipers off.

**Note:** If streaks or smears appear on the windshield, clean the windshield and the wiper blades. If that does not resolve the issue, install new wiper blades. See **Changing the Front Wiper Blades** (page 249).

# Wipers and Washers

## WINDSHIELD WASHERS



E144498

Pull the lever toward you to operate the windshield washers. When you release the lever, the wipers operate for a short time.

**Note:** Do not operate the washers when the washer reservoir is empty. This may cause the washer pump to overheat.

## REAR WINDOW WIPER AND WASHERS

### Rear Window Wiper



E171615

- A Intermittent wipe.
- B Continuous wipe.
- C Rear window wiper off.

Press the top of the button to switch intermittent wipe on. Press the top of the button again to switch continuous wipe on. Press the bottom of the button to switch the rear window wiper off.

**Note:** Make sure you switch the rear window wiper off before entering a car wash.

### Reverse Gear Wipe (If Equipped)

If you shift to reverse (R) when the windshield wipers are on, the rear window wiper turns on.

### Rear Window Washer

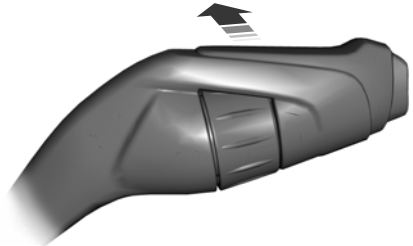

E167407

Push the lever away from you to operate the rear window washer. When you release the lever, the wipers operate for a short time.

# Lighting

## GENERAL INFORMATION

### Condensation in the Exterior Front Lamps and Rear Lamps

Exterior front lamps and rear lamps have vents to accommodate normal changes in air pressure.

Condensation can be a natural by-product of this design. When moist air enters the lamp assembly through the vents, there is a possibility that condensation can occur when the temperature is cold. When normal condensation occurs, a fine mist can form on the interior of the lens. The fine mist eventually clears and exits through the vents during normal operation.

Clearing time may take as long as 48 hours under dry weather conditions.

Examples of acceptable condensation are:

- The presence of a fine mist (no streaks, drip marks or large droplets).
- A fine mist covers less than 50% of the lens.

Examples of unacceptable condensation are:

- A water puddle inside the lamp.
- Streaks, drip marks or large droplets present on the interior of the lens.

If you see any unacceptable condensation, have your vehicle checked by an authorized dealer.

## LIGHTING CONTROL

### Lighting Control Positions

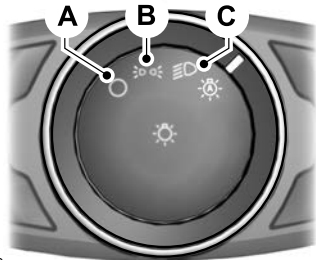

E142449

- A Off.
- B Parking lamps, instrument panel lamps, license plate lamps and tail lamps.
- C Headlamps.

### Parking Lamps

**Note:** Prolonged use of the parking lamps will cause the battery to run out of charge.

**Note:** Parking lamps may turn off automatically. This prevents the vehicle battery from running out of charge.

Switch the ignition off.

### Both Sides

Select position B on the lighting control to switch the parking lamps on.

# Lighting

## One Side

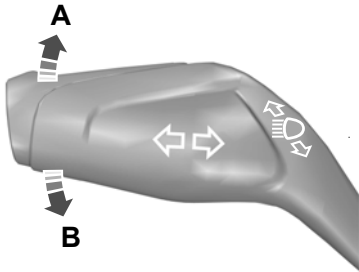

E163717

- A Right-hand side.
- B Left-hand side.

## Headlamp High Beam



E163718

Push the lever away from you to switch the high beam on.

Push the lever forward again or pull the lever toward you to switch the high beams off.

## Headlamp Flasher



E163719

Slightly pull the lever toward you and release it to flash the headlamps.

## Home Safe Lighting

### Switching the System On

Switch the ignition off and pull the direction indicator lever toward the steering wheel. A tone will sound.

### Switching the System Off

It will turn off automatically after three minutes with a door open or 30 seconds after the last door closes. Alternatively, pull the direction indicator lever toward the steering wheel or switch the ignition on.

## AUTOLAMPS



**WARNING:** The system does not relieve you of your responsibility to drive with due care and attention. You may need to override the system if it does not turn the headlamps on in low visibility conditions, for example daytime fog.

# Lighting

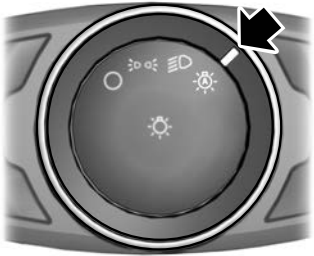

E142451

When the lighting control is in the autolamps position, the headlamps turn on in low light situations, or when the wipers turn on.

The headlamps remain on for a period of time after you switch the ignition off. Use the information display controls to adjust the period of time that the headlamps remain on.

**Note:** *If you switch the autolamps on, you cannot switch the high beams on until the system turns the low beams on.*

## Windshield Wiper Activated Headlamps

When you switch the autolamps on, the headlamps turn on within 10 seconds of switching the wipers on. They turn off approximately 60 seconds after you switch the windshield wipers off.

The headlamps do not turn on with the wipers:

- During a single wipe.
- When using the windshield washers.
- If the wipers are in intermittent mode.

**Note:** *If you switch the autolamps and the autowipers on, the headlamps turn on when the windshield wipers continuously operate.*

## INSTRUMENT LIGHTING DIMMER

The instrument lighting dimmer buttons are on the lighting control.



Repeatedly press one of the buttons to adjust the brightness.



## HEADLAMP EXIT DELAY

After you switch the ignition off, you can switch the headlamps on by pulling the direction indicator lever toward you. You will hear a short tone. The headlamps will switch off automatically after three minutes with any door open or 30 seconds after the last door has been closed. You can cancel this feature by pulling the direction indicator toward you again or switching the ignition on.

## AUTOMATIC HIGH BEAM CONTROL



**WARNING:** The system does not relieve you of your responsibility to drive with due care and attention. You may need to override the system if it does not turn the high beams on or off.



**WARNING:** You may need to override the system when approaching other road users.



**WARNING:** You may need to override the system during inclement weather.

# Lighting



**WARNING:** Do not use the system in poor visibility, for example fog, heavy rain, spray or snow.



**WARNING:** The system may not switch the high beams off if the lights of oncoming vehicles are hidden by obstacles, for example guard rails.



**WARNING:** Inspect and replace the windshield wiper blades regularly to make sure the camera sensor has a clear view. The windshield wiper blades must be the correct length.

- The ambient light level is low enough that high beams are required.
- There is no traffic in front of your vehicle.
- Your vehicle speed is greater than approximately 40 km/h (25 mph).

The system is designed to turn the high beams off if any of the following occur:

- You switch the system off in the information display.
- You set the lighting control to any position except autolamps.
- You switch the rear fog lamps on.
- The ambient light level is high enough that high beams are not required.
- The system detects an approaching vehicle's headlamps or rear lamps.
- The system detects severe rain, snow or fog.
- The system detects street lighting.
- The camera has reduced visibility.
- Your vehicle speed falls below approximately 30 km/h (19 mph).

## About Automatic High Beam Control

The system is designed to turn the high beams on if all of the following occur:

- You switched the system on in the information display.
- You set the lighting control to the autolamps position.

## Switching Automatic High Beam Control On or Off

**To switch the system on or off, use the information display controls on the steering wheel to select the following:**

Menu Item	Action
Settings	Press the menu button.
Vehicle settings	Press the <b>OK</b> button.
Lighting	Press the <b>OK</b> button.
Auto highbeam	Press the <b>OK</b> button.

## Automatic High Beam Indicator



It illuminates to confirm when the system is ready to assist.

## Overriding Automatic High Beam Control

Push the lever away from you to switch between high beam and low beam.

# Lighting

## Automatic High Beam Control Information Messages

Message	Description
Front camera Low visibility Clean screen	The camera has reduced visibility. Clean the windshield. If the message continues to appear, have your vehicle checked as soon as possible.
Front camera temporarily not available	The camera has malfunctioned. Wait a short period of time for the camera to cool down. If the message continues to appear, have your vehicle checked as soon as possible.

## FRONT FOG LAMPS

### Switching the Front Fog Lamps On or Off

Only switch the front fog lamps on during reduced visibility.

You can switch the front fog lamps on if any of the following occur:

- You set the lighting control to the parking lamps position.
- You set the lighting control to the headlamps position.
- You set the lighting control to the autolamps position and the headlamps are on.

The front fog lamp button is on the lighting control.

 Press the button to switch the front fog lamps on or off.

**Note:** *The brightness of the daytime running lamps decreases when the front fog lamps are switched on.*

### Front Fog Lamp Indicator

 It illuminates when you switch the front fog lamps on.

## REAR FOG LAMPS

### Switching the Rear Fog Lamps On or Off

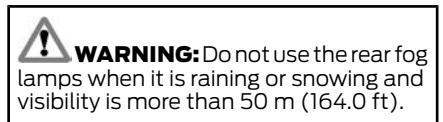

You can switch the rear fog lamps on if any of the following occur:

- You switched the front fog lamps on.
- You set the lighting control to the headlamps position.
- You set the lighting control to the autolamps position and the headlamps are on.

The rear fog lamp button is on the lighting control.

 Press the button to switch the rear fog lamps on or off.

### Rear Fog Lamp Indicator

 It illuminates when you switch the rear fog lamps on.

# Lighting

## HEADLAMP LEVELING

To adjust the level of the headlamp beams, do the following:

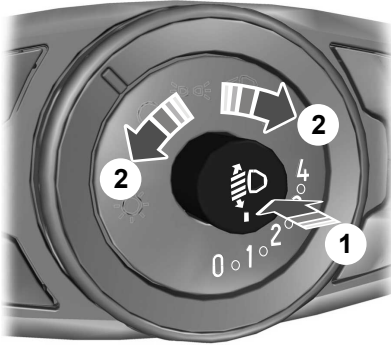

E132711

1. Press to release the control.
2. Rotate the control in accordance with your vehicle load to prevent you from distracting other road users when the headlamps are on.

**Note:** Set the control to zero when your vehicle is unloaded.

**Note:** Set the headlamp beams to give between 35–100 m (115–328 ft) of road surface illumination when your vehicle is partially or fully loaded.

3. Press to close the control.

## CORNERING LAMPS

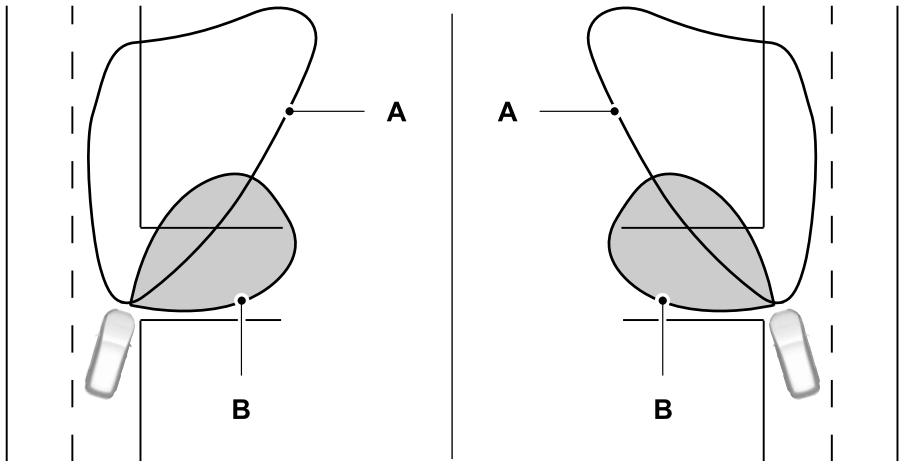

E72898

# Lighting

- A Headlamp beam.
- B Cornering lamp beam.

The cornering lamps illuminate the inside of a corner when you are turning the steering wheel.

## DIRECTION INDICATORS



E162681

Push the lever up or down to use the direction indicators.

**Note:** Tap the lever up or down to make the direction indicators flash three times to indicate a lane change.

## INTERIOR LAMPS

### Courtesy Lamp

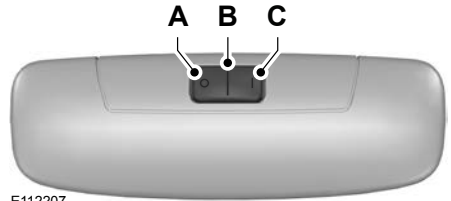

E112207

- A Off
- B Door contact
- C On

If you set the switch to position B, the courtesy lamp will switch on when you unlock your vehicle, open a door or the liftgate. If you leave a door open with the ignition switched off, the courtesy lamp will switch off automatically after a short period of time to prevent your vehicle battery from losing charge. To switch it back on, switch the ignition on for a short period of time.

The courtesy lamp will also switch on when you switch the ignition off. It will switch off automatically after a short period of time or when you start the engine.

If you set the switch to position C with the ignition switched off, the courtesy lamp will switch on. It will switch off automatically after a short period of time to prevent your vehicle battery from losing charge. To switch it back on, switch the ignition on for a short period of time.

# Lighting

---

## Reading Lamps



E112208

If you switch the ignition off, the reading lamps will switch off automatically after a short period of time to prevent your vehicle battery from losing charge. To switch them back on, switch the ignition on for a short period of time.

# Windows and Mirrors

## POWER WINDOWS - VEHICLES WITH: REAR POWER WINDOWS



**WARNING:** Do not leave children unattended in your vehicle and do not let them play with the power windows. Failure to follow this instruction could result in personal injury.



**WARNING:** When closing the power windows, verify they are free of obstruction and make sure that children and pets are not in the proximity of the window openings.



Press the control to open the window. Lift the control to close the window.

**Note:** *The power windows operate with the ignition on, and for several minutes after you switch the ignition off or until you open a front door.*

To reduce wind noise or pulsing noise when just one window is open, slightly open the opposite window.

### One-Touch Open (If Equipped)

Fully press the control and release it. Press again or lift it to stop the window.

### One-Touch Close (If Equipped)

Fully lift the control and release it. Press again or lift it to stop the window.

### Resetting One-Touch Close

Start the engine.

1. Lift and hold the control until you fully close the window. Continue to hold the control for a few seconds after you close the window.

2. Release the control.
3. Press and hold the control until you fully open the window.
4. Release the control.
5. Lift and hold the control until you fully close the window.
6. Test for correct window operation by opening and closing the windows using one-touch.

### Bounce-Back

The window stops and reverses if it detects an obstruction.

### Overriding Bounce-Back



**WARNING:** If you override bounce-back, the window does not reverse if it detects an obstacle. Take care when closing the windows to avoid personal injury or damage to your vehicle.

1. Close the window until it reaches the point of resistance and let it reverse.
2. Lift the control within a few seconds to override bounce-back and close the window. Bounce-back is now disabled and you can close the window manually.

**Note:** *The window goes past the point of resistance and you can fully close it.*

**Note:** *If the window does not close, have your vehicle checked as soon as possible.*

### Rear Window Lock



Press the control to lock or unlock the rear window controls. It illuminates when you lock the rear window controls.

# Windows and Mirrors

## POWER WINDOWS - VEHICLES WITH: ONE-TOUCH OPEN DRIVER WINDOW



**WARNING:** Do not leave children unattended in your vehicle and do not let them play with the power windows. Failure to follow this instruction could result in personal injury.



**WARNING:** When closing the power windows, verify they are free of obstruction and make sure that children and pets are not in the proximity of the window openings.



Press the control to open the window. Lift the control to close the window.

**Note:** *The power windows operate with the ignition on, and for several minutes after you switch the ignition off or until you open a front door.*

To reduce wind noise or pulsing noise when just one window is open, slightly open the opposite window.

### One-Touch Open (If Equipped)

Fully press the control and release it. Press again or lift it to stop the window.

## GLOBAL OPENING AND CLOSING

### Global Opening

1. Press and release the unlock button on the remote control.
2. Press and hold the unlock button on the remote control.
3. Release the button when the windows start to open.

Press the lock or the unlock button on the remote control to stop global opening.

**Note:** *You can use global opening for a short period of time when you unlock your vehicle using the remote control.*

### Global Closing



**WARNING:** When closing the power windows, verify they are free of obstruction and make sure that children and pets are not in the proximity of the window openings.

1. Press and hold the lock button on the remote control.
2. Release the button when the windows start to close.

Press the lock or the unlock button on the remote control to stop global closing.

**Note:** *Bounce-back is on during global closing.*

## EXTERIOR MIRRORS

### Adjusting the Mirrors



**WARNING:** Do not adjust the mirrors when your vehicle is moving. This could result in the loss of control of your vehicle, serious personal injury or death.

# Windows and Mirrors

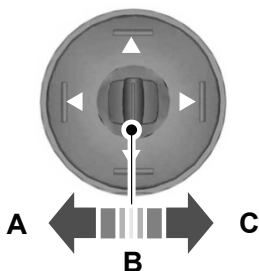

E70846

- A Left-hand mirror switch.
- B Mirror adjustment control.
- C Right-hand mirror switch.

## Folding the Mirrors

### Vehicles with Manual Fold

Push the mirror toward the door window glass.

Make sure that you fully engage the mirror in its support when returning it to its original position.

### Vehicles with Auto-fold

The exterior mirrors fold when you lock your vehicle and unfold when you unlock your vehicle.



For tight parking conditions, press the control to fold the mirrors.

Press the control again to unfold the mirrors.

If you press the control to fold in the mirrors with auto-fold on, the mirrors do not unfold when you unlock your vehicle.

You can switch auto-fold on or off in the information display. See **General Information** (page 80).

**Note:** The power folding mirrors operate with the ignition on, and for several minutes after you switch the ignition off.

**Note:** If you fold and unfold the mirrors several times within one minute, the power fold function may turn off to protect the motors from overheating.

## INTERIOR MIRROR - VEHICLES WITHOUT: AUTO-DIMMING INTERIOR MIRROR



**WARNING:** Do not adjust the mirrors when your vehicle is moving. This could result in the loss of control of your vehicle, serious personal injury or death.

Pull the tab below the mirror toward you to reduce the effect of bright light from behind.

## INTERIOR MIRROR - VEHICLES WITH: AUTO-DIMMING INTERIOR MIRROR



**WARNING:** Do not adjust the mirrors when your vehicle is moving. This could result in the loss of control of your vehicle, serious personal injury or death.

The mirror dims to reduce the effect of bright light from behind. It returns to normal when the bright light from behind is no longer present or if you shift into reverse (R).

Do not block the sensors on the front and back of the mirror.

**Note:** A rear center passenger or raised rear center head restraint could prevent light from reaching the sensor.

# Windows and Mirrors

## SUN SHADES

 **WARNING:** Do not let children play with the sun shade or leave them unattended in the vehicle. They may seriously hurt themselves.

 **WARNING:** When closing the sun shade, you should verify that it is free of obstructions and make sure that children and pets are not in the proximity of the sunshade.

The control is located in the overhead console.

The sun shade has a one-touch open and close feature. To stop motion during one-touch operation, press the control a second time.

### Opening and Closing the Sun Shade



E223717

Fully press and release the front of the control to open the sun shade.

Fully press and release the rear of the control to close the sun shade.

## Bounce-Back

The sun shade will stop automatically while closing. It will reverse some distance if there is an obstacle in the way.

## Sun Shade Relearning

 **WARNING:** The bounce-back function is not active during this procedure. Make sure that there are no obstacles in the way of the moving sun shade.

**Note:** You must start the relearning process within 30 seconds of switching the ignition on.

In case the sun shade no longer opens or closes properly, follow this relearning procedure:

1. Press the front of the control to the first action point twice and release it within two seconds.
2. Press the rear of the control to the first action point twice and release it within two seconds.
3. Press and hold the front of the control to the first action point, until the sun shade fully opens.
4. Press and hold the rear of the control to the first action point, until the sun shade fully closes.

If you do not complete Step 2 within 15 seconds of Step 1, the relearning function end. Switch the ignition off, wait for another 30 seconds and then switch the ignition back on again. Start the procedure again from the beginning.

Confirm that relearning was successful by opening and closing the sun shade.

# Instrument Cluster

## GAUGES

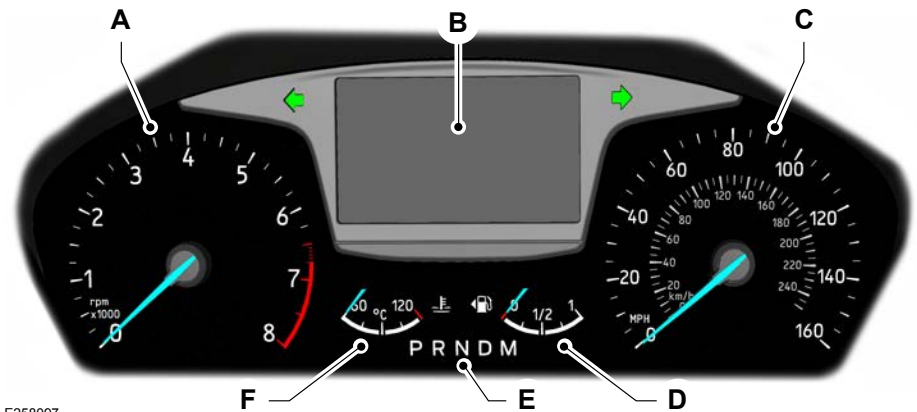

- A Tachometer.
- B Information display.
- C Speedometer.
- D Fuel gauge.
- E Automatic transmission gearshift lever position indicator.
- F Engine coolant temperature gauge.

## Information Display

### Odometer

Records the total distance traveled by your vehicle.

The system detects unauthorized odometer adjustments to avoid total distance reading fraud. If the system detects an unauthorized odometer adjustment, the total distance reading displays XXXX. Recovery of the original mileage could result in system damage not covered by the vehicle Warranty and may carry a significant expense.

### Trip Computer

See **Trip Computer** (page 82).

### Vehicle Settings and Personalization

See **Personalized Settings** (page 82).

### Fuel Gauge

The fuel gauge indicates approximately how much fuel is in the fuel tank.

The arrow adjacent to the fuel pump symbol indicates on which side of your vehicle the fuel filler door is located.

# Instrument Cluster



A



B

E236403

- A The fuel filler door is on the left-hand side of your vehicle.
- B The fuel filler door is on the right-hand side of your vehicle.

## Engine Coolant Temperature Gauge

At normal operating temperature, the needle remains in the center section. If the needle enters the red section, the engine is overheating. Stop your vehicle as soon as it is safe to do so, switch the engine off and allow it to cool.

**Note:** *The system reduces the engine speed if you continue to operate the engine at a high engine speed.*

**Note:** *Do not restart the engine until the cause of overheating has been determined and resolved.*

## WARNING LAMPS AND INDICATORS

The following warning lamps and indicators alert you to a vehicle condition that may become serious. Some lamps illuminate when you start your vehicle to make sure they work. If any lamps remain on after starting your vehicle, refer to the respective system warning lamp for further information.

**Note:** *Some warning indicators appear in the information display and operate the same as a warning lamp but do not illuminate when you start your vehicle.*

### Airbag Warning Lamp



If it does not illuminate when you switch the ignition on, continues to flash or remains on when the engine is running, this indicates a malfunction. Have your vehicle checked as soon as possible.

### Anti-Lock Brake System Warning Lamp



If it illuminates when you are driving, this indicates a malfunction. Your vehicle continues to have normal braking without the anti-lock brake system function. Have your vehicle checked as soon as possible.

### Auto-Start-Stop Indicator



It illuminates when the engine has automatically stopped. It flashes to inform you when the engine needs to restart. The indicator is shown with a strikethrough if the system is not available.

### Battery Warning Lamp



If it illuminates when driving, this indicates a malfunction. Switch off all unnecessary electrical equipment. Have your vehicle checked as soon as possible.

### Blind Spot Information System Indicator (If Equipped)



It illuminates when you switch the system off.

See **Blind Spot Information System** (page 200).

# Instrument Cluster

## Brake System Warning Lamp



**WARNING:** Driving your vehicle with the warning lamp on is dangerous. A significant decrease in braking performance may occur. It may take you longer to stop your vehicle. Have your vehicle checked as soon as possible. Driving extended distances with the parking brake engaged can cause brake failure and the risk of personal injury.



It illuminates when you engage the parking brake and the ignition is on.

If it illuminates when your vehicle is moving, make sure the parking brake is disengaged. If the parking brake is disengaged, this indicates low brake fluid level or a brake system fault. Have your vehicle checked immediately.

## Cruise Control Indicator



It illuminates when you switch the system on.

See **Using Cruise Control** (page 185).

## Direction Indicator



Flashes during operation. An increase in the rate of flashing warns of a failed indicator bulb.

## Engine Coolant Temperature Warning Lamp



If it illuminates when your vehicle is moving, this indicates that the engine is overheating. Stop your vehicle as soon as it is safe to do so and switch the engine off. Have your vehicle checked as soon as possible.

## Engine Warning Lamps



Malfunction Indicator Lamp



Powertrain Warning Lamp

If it illuminates when the engine is running this indicates a malfunction. If it flashes when you are driving, reduce the speed of your vehicle immediately. If it continues to flash, avoid heavy acceleration or deceleration. Have your vehicle checked as soon as possible.

If both lamps illuminate when the engine is running, stop your vehicle as soon as it is safe to do so. Continuing to drive your vehicle may cause reduced power or the engine to stop. Switch the ignition off and attempt to restart the engine. Have your vehicle checked as soon as possible.

## Fasten Seatbelt Warning Lamp



It illuminates and a chime sounds until you fasten the seatbelts.

## Front Fog Lamp Indicator



It illuminates when you switch the front fog lamps on.

## Frost Warning Lamp



**WARNING:** Even if the temperature rises to above 4°C (39°F) there is no guarantee that the road is free of hazards caused by inclement weather.



It illuminates when the outside air temperature is 4°C (39°F) or below.

# Instrument Cluster

## Glow Plug Indicator



If it illuminates, wait until it turns off before starting.

## Headlamp High Beam Indicator



It illuminates when you switch the headlamp high beam on.

## Ignition Warning Lamp



If it illuminates when the engine is running this indicates a malfunction. Have your vehicle checked as soon as possible.

## Lamps on Indicator



It illuminates when you switch the headlamp low beam or the side and rear lamps on.

## Low Fuel Level Warning Lamp



If it illuminates when you are driving, refuel as soon as possible.

## Low Tire Pressure Warning Lamp

(If Equipped)



It illuminates if the tire pressure in one or more tires is below the correct tire pressure.

See **Tire Pressure Monitoring System** (page 266).

## Message Center Indicator



It illuminates when a new message is stored in the information display. The indicator is red or amber depending on the severity of the condition and it remains on until the condition is resolved.

See **Information Messages** (page 82).

## Oil Pressure Warning Lamp



**WARNING:** If it illuminates when you are driving do not continue your journey, even if the oil level is correct. Have your vehicle checked.



If it illuminates when the engine is running this indicates a malfunction. Stop your vehicle as soon as it is safe to do so and switch the engine off. Check the engine oil level. If the oil level is sufficient, this indicates a system malfunction. Have your vehicle checked immediately.

See **Engine Oil Check** (page 245).

## Rear Fog Lamp Indicator



It illuminates when you switch the rear fog lamps on.

## Shift Indicator



It illuminates to advise you that shifting to a higher or lower gear may give better performance, fuel economy or lower emissions.



## Stability Control and Traction Control Indicator



Flashes during operation. If it does not illuminate when you switch the ignition on, or remains on when the engine is running, this indicates a malfunction. Have your vehicle checked as soon as possible.

# Instrument Cluster

---

## Stability Control and Traction Control Off Warning Lamp



It illuminates when you switch the system off.

## Automatic Transmission Warning Chime

Sounds when you have not moved the transmission selector lever to park. A message will be shown in the display.

## AUDIBLE WARNINGS AND INDICATORS - MANUAL TRANSMISSION

### Headlamps On Warning Chime

Sounds when you remove the key from the ignition and open the driver door and you have left the headlamps or parking lamps on.

### Parking Brake On Warning Chime

Sounds when you have left the parking brake on and drive your vehicle. If the warning chime remains on after you have released the parking brake, have your vehicle checked by an authorized dealer immediately.

## AUDIBLE WARNINGS AND INDICATORS - AUTOMATIC TRANSMISSION

### Headlamps On Warning Chime

Sounds when you remove the key from the ignition and open the driver door and you have left the headlamps or parking lamps on.

### Parking Brake On Warning Chime

Sounds when you have left the parking brake on and drive your vehicle. If the warning chime remains on after you have released the parking brake, have your vehicle checked by an authorized dealer immediately.

# Information Displays

## GENERAL INFORMATION



**WARNING:** Driving while distracted can result in loss of vehicle control, crash and injury. We strongly recommend that you use extreme caution when using any device that may take your focus off the road. Your primary responsibility is the safe operation of your vehicle. We recommend against the use of any hand-held device while driving and encourage the use of voice-operated systems when possible. Make sure you are aware of all applicable local laws that may affect the use of electronic devices while driving.

**Note:** For your safety, some features are speed-dependent. Their use is limited to when your vehicle speed is not moving.

## Information Display Controls



E275331

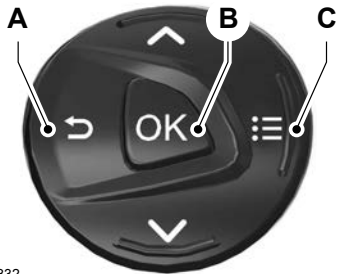

E275332

- A Return button.
- B OK button.
- C Menu button.

### Return Button

Use the return button to go back or to exit.

### OK Button

Use the **OK** button to make a selection. You can also use it to scroll through a menu.

### Menu Button

Use the menu button on the main screen to display the submenu.

## Information Display Menus

### Main Menu

Menu Item
<b>Trip computer 1</b> or <b>Trip computer 2</b>
MyView
Driver assist.
Navigation

# Information Displays

Menu Item
Audio
Phone
Settings

## Submenus

### *Trip computer 1 and Trip computer 2*

Menu Item
Trip computer 1
Trip computer 2
Reset individual values
Configure view

## MyView

Menu Item
Digital speedometer
Fuel economy
Trip computer/audio
Eco coach
Calm screen

## Driver assist.

Menu Item
Traction control
BLIS
Pre-collision Assist
Traffic sign recognition
Lane keeping system
Driver alert

Menu Item
Wrong way alert
Hill Start Assist
Cross traffic alert
Eco coach
Trailer control
Cruise control
Speed limiter
Rear Park Pilot

## Navigation

Menu Item
Home
Favourite destinations
Previous destinations

## Audio

Menu Item
Radio
CD
USB device.
Bluetooth device.

## Phone

Menu Item
All calls
Incoming calls
Missed calls
Outgoing calls

# Information Displays

## Settings

Menu Item
Information
Display
Driver assistance
Vehicle settings
Vehicle maintenance
MyKey

## TRIP COMPUTER

### Resetting the Trip Computer

Press and hold **OK** on the current screen to reset the respective trip, distance, time and average fuel information.

### Trip Odometer

Registers the distance traveled of individual journeys.

### Distance to Empty

Indicates the approximate distance your vehicle will travel on the fuel remaining in the tank. Changes in driving pattern may cause the value to vary.

## INFORMATION MESSAGES

### Active Park Assist

Message	Description
Active Park malfunction	The system has malfunctioned. Have your vehicle checked as soon as possible.

## Average Fuel

Indicates the average fuel consumption since the function was last reset.

## Digital Speedometer

The speed your vehicle is traveling at will display as a digital number.

## PERSONALIZED SETTINGS

### Measure Units

To swap between imperial and metric units, scroll to this display and press the **OK** button.

Swapping between imperial and metric units will affect the following displays:

- Distance to empty.
- Average fuel consumption.
- Instantaneous fuel consumption.
- Average speed.

### Switching Chimes Off

The following chimes can be switched off:

- Warning messages.
- Information messages.

# Information Displays

## Adaptive Cruise Control

Message	Description
Adaptive cruise control malfunction	The system has malfunctioned. Have your vehicle checked as soon as possible.
Adaptive cruise control not available	The system is not available. See <b>Using Adaptive Cruise Control</b> (page 186).
Adaptive cruise control not available Sensor blocked See manual	The radar has reduced visibility. See <b>Using Adaptive Cruise Control</b> (page 186).
Cruise control active Adaptive braking off	You have switched normal cruise control on. Adaptive braking turns off.
Front sensor not aligned	The system has malfunctioned. Have your vehicle checked as soon as possible.
Adaptive cruise control Driver resume control	The adaptive cruise has reinstated controls to the driver.
Adaptive cruise control Speed too low to activate	Your vehicle speed is too slow to activate the adaptive cruise.
Adaptive cruise control Speed sign recognition not available	Navigation system based speed limit information is not available. If the message continues to appear, have your vehicle checked as soon as possible.

## Alarm

Message	Description
Vehicle alarm Start vehicle to stop alarm	Displays when the alarm has been triggered due to unauthorized entry.

# Information Displays

## Automatic High Beam Control

Message	Description
Front camera Low visibility Clean screen	The camera has reduced visibility. Clean the windshield. If the message continues to appear, have your vehicle checked as soon as possible.
Front camera temporarily not available	The camera has malfunctioned. Wait a short period of time for the camera to cool down. If the message continues to appear, have your vehicle checked as soon as possible.
Front camera malfunction Service required	The camera has malfunctioned. Have your vehicle checked as soon as possible.

## Auto-Start-Stop

Message	Description
Auto StartStop Press Brake to Start Engine	The system needs to restart the engine but requires your confirmation. Press the brake pedal to restart the engine.
Auto StartStop Press clutch to start engine	The system needs to restart the engine but requires your confirmation. Press the clutch pedal to restart the engine.
Auto StartStop Press a Pedal to Start Engine	The system needs to restart the engine but requires your confirmation. Press any pedal to restart the engine.
Auto StartStop Select Neutral To Start Engine	The system needs to restart the engine but requires your confirmation. Shift into neutral (N) to restart the engine.
Auto StartStop Shift to P, then Restart Engine	The system needs to restart the engine but requires your confirmation. Shift into park (P) to restart the engine.
Auto StartStop Manual Restart Required	The system is not functioning. Restart the engine.
Auto StartStop malfunction Service required	The system has malfunctioned. Have your vehicle checked as soon as possible.

# Information Displays

## Blind Spot Information and Cross Traffic Alert Systems

Message	Description
BLIS malfunction	The system has malfunctioned. Have your vehicle checked as soon as possible.
BLIS not available Sensor blocked See manual	The system sensors are blocked. See <b>Blind Spot Information System</b> (page 200).
BLIS deactivated Trailer attached	You have attached a trailer to your vehicle. The system turns off.
Vehicle coming from left Vehicle coming from right	The system detects a vehicle. See <b>Blind Spot Information System</b> (page 200).
Cross traffic alert	Displays instead of indication arrows when the system detects a vehicle. Check for approaching traffic.
Cross traffic malfunction	The system has malfunctioned. Have your vehicle checked as soon as possible.
Cross traffic not available Sensor blocked See manual	The system sensors are blocked. See <b>Cross Traffic Alert</b> (page 202).
Cross traffic alert deactivated Trailer attached	You have attached a trailer to your vehicle. The system turns off.
Cross traffic alert Applying brakes	The system applies the brakes. Check for approaching traffic.

## Brake System

Message	Description
Check brake system	The system has malfunctioned. Stop your vehicle in a safe place. Have your vehicle checked as soon as possible.

# Information Displays

## Doors and Locks

Message	Description
Driver door open Passenger door open Rear left door open Rear right door open Liftgate open	The door listed is not completely closed.
Bonnet open	The hood is not completely closed.
Switches inhibited Security mode	The system has disabled the door switches.

## Driver Alert

Message	Description
Driver fatigue warning Rest now	Take a break due to low alertness levels.
Driver fatigue warning Rest suggested	We recommend that you take a break due to low alertness levels.

## Engine

Message	Description
Engine coolant overtemperature	Displays when the engine temperature is too high. Stop your vehicle as soon as it is safe to do so, switch the engine off and allow it to cool. Have your vehicle checked as soon as possible.

# Information Displays

## Fuel System

Message	Description
Fuel level low	An early reminder of a low fuel condition.
Fuel level low distance metric:##0 km to empty	
Fuel level low distance imperial:##0 miles to empty	
Check fuel fill inlet	The fuel fill inlet may not be properly closed.
Fuel pressure low	The system has malfunctioned. Have your vehicle checked as soon as possible.
Water in fuel Drain filter	The system detects there is excess water in the fuel filter. Have your vehicle checked as soon as possible.

## Headlamps

Message	Description
Check adaptive headlamps See manual	Displays if an electrical malfunction occurs with the headlamp system. Have your vehicle checked as soon as possible.

## Hill Start Assist

Message	Description
Hill start assist not available	The system is not available. Have your vehicle checked as soon as possible. See <b>Hill Start Assist</b> (page 164).

## Lane Keeping System

Message	Description
Lane keeping system malfunction Service required	The system has malfunctioned. Have your vehicle checked as soon as possible.

# Information Displays

## Maintenance

Message	Description
Engine oil level low Add oil	The engine oil level is low. Stop your vehicle as soon as it is safe to do so and switch the engine off. Check the engine oil level. See <b>Engine Oil Check</b> (page 245). If the message continues to appear, have your vehicle checked as soon as possible.
Engine oil pressure low	The engine oil pressure is low. Stop your vehicle as soon as it is safe to do so and switch the engine off. Check the engine oil level. See <b>Engine Oil Check</b> (page 245). If the message continues to appear, have your vehicle checked as soon as possible.
Change engine oil soon	The engine oil life remaining is 10% or less. See <b>Engine Oil Check</b> (page 245).
Oil change required	The oil life left is at 0%. See <b>Engine Oil Check</b> (page 245).
Brake fluid level low	The brake fluid level is low or the brake system has malfunctioned. See <b>Brake Fluid Check</b> (page 248). Have your vehicle checked as soon as possible.
Power reduced to lower engine temperature	The engine has reduced power to help reduce high engine temperature.
Transport mode Contact dealer	Transport mode is on. This may not allow some features to properly operate. Have your vehicle checked as soon as possible.
Factory mode Contact dealer	Factory mode is on. This may not allow some features to properly operate. Have your vehicle checked as soon as possible.
Washer fluid level low	The washer fluid is low and needs to be refilled. See <b>Washer Fluid Check</b> (page 248).

## Information Displays

### MyKey

Message	Description
Place key in backup location	Displays when trying to create a MyKey and the key is not placed in the backup position. See <b>Passive Key Backup Position</b> (page 48).
Key is already a MyKey	Displays when trying to create a MyKey with a key already designated as a MyKey.
Hold OK to create MyKey	Displays when creating a MyKey.
Creation completed	Displays to confirm that a MyKey has been created.
Key restricted at next start. Label this key	Displays to confirm that the key is restricted after you switch the ignition off.
MyKey not created	Displays if the system fails to create a MyKey.
Hold OK to clear MyKeys	Displays when clearing all MyKeys.
All MyKeys cleared	Displays to confirm that all MyKeys have been cleared.

### Parking Aid

Message	Description
Parking aid malfunction	The system has malfunctioned. Have your vehicle checked as soon as possible.
Check Park Pilot	
Check front Park Pilot Check rear Park Pilot	
Park Pilot not available sensor blocked See Manual	The system sensors are blocked. See <b>Parking Aids</b> (page 169).
Front Park Pilot not available sensor blocked See Manual	
Rear Park Pilot not available Sensor blocked See manual	
Rear Park Pilot disabled Trailer attached	You have attached a bike rack, trailer or other object near the sensors on the front or rear of your vehicle.

# Information Displays

## Parking Brake

Message	Description
Park brake applied	You have not released the parking brake and your vehicle reaches 5 km/h (3 mph). If the message continues to appear after you have released the parking brake, have your vehicle checked as soon as possible.

## Parking Heater

Message	Description
Park heater not started Low fuel level	Displays if the parking heater fails to operate due to low fuel level. Refuel as soon as possible.

## Pre-Collision Assist

Message	Description
Pre-collision assist not available	The system has malfunctioned. Have your vehicle checked as soon as possible.
Pre-collision assist not available Sensor blocked	The system sensors are blocked. See <b>Pre-Collision Assist</b> (page 209).

## Rear Window Lock

Message	Description
Child lock malfunction See manual	The system has malfunctioned. Have your vehicle checked as soon as possible.

## Remote Control

Message	Description
Key battery low Replace soon	The key battery is low. Change the battery as soon as possible.

# Information Displays

## Seatbelt Reminder

Message	Description
Rear belt monitor malfunction Service required	The system has malfunctioned. Have your vehicle checked as soon as possible.

## Selective Catalytic Reductant System

### Diesel Exhaust Fluid (AdBlue) Level

Message	Description
Adblue® Low Range: Distance Metric :###0 Km Refill Soon  Adblue® Low Range: Distance Imperial :###0 Mls Refill Soon	Refill the diesel exhaust fluid tank as soon as possible. See <b>Selective Catalytic Reductant System</b> (page 149).
Adblue® Low No Engine Start In Distance Metric:###0 Km  Adblue® Low No Engine Start In Distance Imperial:###0 Mls	
Adblue® Level Empty. Refill To Start Engine	The diesel exhaust fluid tank is empty. Refill the diesel exhaust fluid tank. The minimum AdBlue refill quantity required to restart the engine is 5 L (1.1 gal). See <b>Selective Catalytic Reductant System</b> (page 149).

# Information Displays

## Diesel Exhaust Fluid (AdBlue) System Malfunction

Message	Description
Adblue® System No Engine Start In Distance Metric:###0 Km	The system has malfunctioned. Have your vehicle checked as soon as possible.
Adblue® System No Engine Start In Distance Imperial:###0 Mls	
Adblue® System Malfunction Service Required	
Adblue® System Service Required To Start Engine	

## Stability Control

Message	Description
ESC Service required	The system has malfunctioned. Have your vehicle checked as soon as possible.

## Starting System

Message	Description
Full accessory power active	Displays if you switch the ignition on and do not start the engine.
Press brake to start	A reminder to press the brake pedal when starting your vehicle.
Press clutch to start	A reminder to press the clutch pedal when starting your vehicle.
Press brake and clutch to start	A reminder to press the brake and clutch pedals when starting your vehicle.
Cranking time exceeded	Displays if your vehicle fails to start.

## Information Displays

Message	Description
No key detected	The system does not detect a valid passive key inside your vehicle.
Starting system malfunction	The system has malfunctioned. Have your vehicle checked as soon as possible.
Restart now or key is needed	Displays if you switch the engine off and the system does not detect a valid passive key inside your vehicle.

### Steering System

Message	Description
Steering loss Stop safely	The system has malfunctioned. Stop your vehicle in a safe place. Have your vehicle checked as soon as possible.
Steering malfunction Service now	The system has malfunctioned. Have your vehicle checked as soon as possible.
Steering assist malfunction Service required	
Steering Lock Malfunction Service Now	

### Tire Pressure Monitoring System

Message	Description
Tyre pressure low	One or more tires on your vehicle have low tire pressure.
Tyre pressure monitor malfunction	The system has malfunctioned. Have your vehicle checked as soon as possible.
Tyre pressure sensor malfunction	The system has malfunctioned or the spare tire is in use. If the message continues to appear, have your vehicle checked as soon as possible.

# Information Displays

## Transmission

Message	Description
Transmission malfunction Service now Transmission Service required	The system has malfunctioned. Have your vehicle checked as soon as possible.
Transmission overtemperature Stop safely Transmission overheating Stop safely Transmission too hot Press brake	The transmission is overheating and needs to cool. Stop your vehicle as soon as it is safe to do so, switch the engine off and allow the transmission to cool. If the message continues to appear, have your vehicle checked as soon as possible.
Transmission limited function See manual	The transmission has limited functionality. Have your vehicle checked as soon as possible.
Transmission warming up Please wait	Displays at low outside temperatures, if it takes a few seconds for the transmission to engage a gear. Fully press the brake pedal until the message disappears from the information display.
Transmission not in Park	Displays as a reminder to shift into park (P).
Press brake to unlock selector lever	Press the brake pedal to unlock the transmission.
Selector lever unlocked	Displays when the selector lever unlocks.

## Wireless Accessory Charging

Message	Description
Wireless charger active	Wireless charging has started.
Charging terminated Phone misaligned or object between phone and charger detected. Correct the condition to resume charging.	Wireless charging has stopped. Remove objects from the charging surface and place phone on center of charging surface.

# Climate Control

## MANUAL CLIMATE CONTROL

### Switching the Climate Control On and Off



### Switching the Recirculated Air On and Off



**Note:** The air currently in the passenger compartment recirculates.

### Switching the Air Conditioning On and Off



**Note:** Under certain conditions, the air conditioning compressor could continue to operate after you switch air conditioning off.

### Switching Maximum Defrost On and Off



Turn the temperature control clockwise past the highest setting to maximize defrosting.

**Note:** The temperature control springs back to the highest setting.

**Note:** When you switch maximum defrost on, the heated windshield, heated rear window and air conditioning turn on.

**Note:** When you switch maximum defrost off, the heated windshield and heated rear window remain on.

### Switching Maximum Cooling On and Off



Turn the temperature control counterclockwise past the lowest setting to maximize cooling.

**Note:** The temperature control springs back to the lowest setting.

**Note:** When you switch maximum cooling off, air conditioning remains on.

### Setting the Blower Motor Speed



**Note:** Lights on the control illuminate to indicate the blower motor speed.

**Note:** When you switch the blower motor off, air conditioning turns off and the windows could fog up.

### Directing Air to the Windshield Air Vents



### Directing Air to the Instrument Panel Air Vents



### Directing Air to the Footwell Air Vents



# Climate Control

## Setting the Temperature

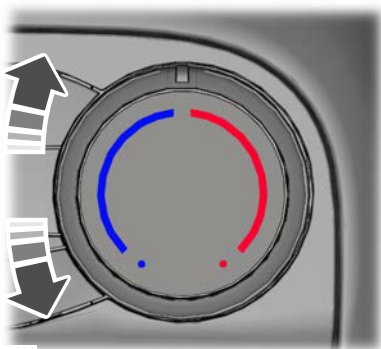

E244106

Turn the temperature control counterclockwise for cooler temperature settings.

Turn the temperature control clockwise for warmer temperature settings.

## AUTOMATIC CLIMATE CONTROL

### Switching the Climate Control On and Off



### Switching the Recirculated Air On and Off



**Note:** The air currently in the passenger compartment recirculates.

**Note:** Recirculated air could turn off or be prevented from turning on in all air flow modes except maximum cooling to reduce the risk of the windows fogging up. It could also turn on and off when you direct air to the instrument panel or footwell air vents during hot weather to improve cooling efficiency.

### Switching the Air Conditioning On and Off



**Note:** Under certain conditions, the air conditioning compressor could continue to operate after you switch air conditioning off.

### Switching Maximum Defrost On and Off



**Note:** When you switch maximum defrost on, the heated windshield, heated rear window and air conditioning turn on. The blower motor is set to the highest speed.

**Note:** When you switch maximum defrost off, the heated windshield and heated rear window remain on.

### Switching Maximum Cooling On and Off



**Note:** When you switch maximum cooling off, air conditioning remains on.

### Switching Auto Mode On and Off



Press the button to switch auto mode on.

Adjust the blower motor control or air distribution control to switch auto mode off.

# Climate Control

## Setting the Blower Motor Speed



Press and release **+** or **-** to set the volume of air circulated in the passenger compartment.

**Note:** Lights on the control illuminate to indicate the blower motor speed.

## Directing Air to the Windshield Air Vents



## Directing Air to the Instrument Panel Air Vents



## Directing Air to the Footwell Air Vents



## Setting the Temperature

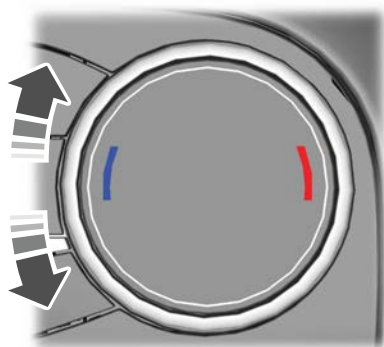

E244115

Turn the temperature control counterclockwise for cooler temperature settings.

Turn the temperature control clockwise for warmer temperature settings.

**Note:** You can adjust the temperature between 15.5–29.5°C (60–85°F).

## HINTS ON CONTROLLING THE INTERIOR CLIMATE - VEHICLES WITH: AUTOMATIC TEMPERATURE CONTROL

### General Hints

Do not place objects under the front seats as this may interfere with directing air to the rear seats.

Remove any snow, ice or leaves from the air intake area at the base of the windshield.

**Note:** You may feel a small amount of air from the footwell air vents regardless of the air distribution setting.

**Note:** To reduce humidity build-up inside your vehicle, do not drive with the system switched off or with recirculated air always switched on.

**Note:** Prolonged use of recirculated air may cause the windows to fog up.

**Note:** Use air conditioning with recirculated air to improve cooling performance and efficiency.

**Note:** When you select automatic mode and the outside temperature is low and the engine is cold, air is directed to the windshield and the outer instrument panel air vents.

**Note:** When you select automatic mode and the outside temperature and in-vehicle temperature is high, the system temporarily selects recirculated air to maximize cooling.

# Climate Control

---

**Note:** When you select maximum defrost, air conditioning turns on and air is directed to the windshield air vents.

## Recommended Settings for Heating

- Press **AUTO**.
- Select the required temperature.

**Note:** Adjusting the settings when your vehicle interior is extremely hot or cold is not necessary. The system automatically adjusts to heat or cool the interior to your selected temperature as quickly as possible. For the system to function efficiently, the instrument panel and side air vents should be fully open.

## Quickly Cooling the Interior

- Press **MAX A/C**.

**Note:** To improve the time to reach a comfortable temperature in hot weather, drive with the windows open until you feel cold air through the air vents.

## Recommended Settings for Cooling

- Press **AUTO**.
- Select the required temperature.

## Defogging the Side Windows in Cold Weather

- Select maximum defrost.

## Defogging or Clearing the Windshield of Thin Ice

- Select maximum defrost.

## HINTS ON CONTROLLING THE INTERIOR CLIMATE - VEHICLES WITH: MANUAL TEMPERATURE CONTROL

### General Hints

Do not place objects under the front seats as this may interfere with directing air to the rear seats.

Remove any snow, ice or leaves from the air intake area at the base of the windshield.

**Note:** You may feel a small amount of air from the footwell air vents regardless of the air distribution setting.

**Note:** To reduce humidity build-up inside your vehicle, do not drive with the system switched off or with recirculated air always switched on.

**Note:** To reduce fogging of the windshield during humid weather conditions, direct air to the windshield air vents.

**Note:** Prolonged use of recirculated air may cause the windows to fog up.

**Note:** Use air conditioning with recirculated air to improve cooling performance and efficiency.

### Quickly Heating the Interior

- Select the highest blower motor speed.
- Select the highest temperature.
- Direct air to the footwell air vents.

### Recommended Settings for Heating

- Select a medium blower motor speed.
- Select the required temperature.
- Direct air to the footwell and windshield air vents.

# Climate Control

## Quickly Cooling the Interior

- Select maximum cooling.

**Note:** To improve the time to reach a comfortable temperature in hot weather, drive with the windows open until you feel cold air through the air vents.

## Recommended Settings for Cooling

- Select a medium blower motor speed.
- Select the required temperature.
- Direct air to the instrument panel air vents.
- Press A/C.

## Defogging the Side Windows in Cold Weather

- Select maximum defrost.

## Defogging or Clearing the Windshield of Thin Ice

- Select maximum defrost.

## HEATED WINDSHIELD



Press the button to clear the windshield of thin ice and fog. The heated windshield turns off after a short period of time.

**Note:** Make sure that the engine is running before switching the heated windshield on.

**Note:** The system does not operate if the battery charge level is low.

## HEATED REAR WINDOW



Press the button to clear the rear window of thin ice and fog. The heated rear window turns off after a short period of time.

**Note:** Make sure the engine is on before operating the heated windows.

**Note:** Do not use razor blades or other sharp objects to clean or remove decals from the inside of the heated rear window. The vehicle Warranty may not cover damage caused to the heated rear window grid lines.

## HEATED EXTERIOR MIRRORS

When you switch the heated rear window on, the heated exterior mirrors turn on.

**Note:** Do not remove ice from the mirrors with a scraper or adjust the mirror glass when it is frozen in place.

**Note:** Do not clean the mirror housing or glass with harsh abrasives, fuel or other petroleum-based cleaning products. The vehicle warranty may not cover damage caused to the mirror housing or glass.

## AUXILIARY HEATER

### Principle of Operation

The system is designed to reduce the time needed to heat the engine when it is running. It turns on or off depending on the outside air temperature and the coolant temperature.

The system warms the engine and the vehicle interior. It uses fuel from the vehicle fuel tank.

### Using the Auxiliary Heater



**WARNING:** We recommend that you have a qualified technician check and repair the heater system after a crash. Failure to follow this instruction could result in personal injury or death.

# Climate Control



**WARNING:** Do not use the fuel-operated parking heater at fuel filling stations or near sources of combustible vapors, dust or in enclosed spaces. This could result in serious personal injury or death.

**Note:** The system does not operate if the battery charge level is low.

**Note:** Make sure the heater exhaust outlet, in front of the right-hand front tire, is free from snow, ice, mud and any other blockages to avoid issues with the heater operation.

**Note:** When the system is on, exhaust fumes come from under your vehicle. This is normal.

**Note:** If the heater is in the process of stopping, excess fuel in the heater burns out and there is some heat, exhaust and noise.

## Switching the Auxiliary Heater On and Off

To switch the auxiliary heater on or off, use the information display controls on the steering wheel to select the following:

Menu Item	Action
Settings	Press the menu button.
Vehicle settings	Press the <b>OK</b> button.
Aux heater	Press the <b>OK</b> button.

## Secondary Interior Heating System Active Indicator



It illuminates when you switch the system on.

## Parking Heater

### Principle of Operation

The system is designed to provide heat when your vehicle is parked.

The system warms the engine and the vehicle interior. It uses fuel from the vehicle fuel tank.

**Note:** Make sure the heater exhaust outlet, in front of the right-hand front tire, is free from snow, ice, mud and any other blockages to avoid issues with the heater operation.

## Using the Parking Heater



**WARNING:** We recommend that you have a qualified technician check and repair the heater system after a crash. Failure to follow this instruction could result in personal injury or death.



**WARNING:** Do not use the fuel-operated parking heater at fuel filling stations or near sources of combustible vapors, dust or in enclosed spaces. This could result in serious personal injury or death.

The system does not operate if the battery charge level is low.

The system only operates when your vehicle is stationary with the engine off.

# Climate Control

When you correctly use the system it:

- Keeps the windows clear of thin ice and helps prevent condensation.

- Assists then engine to reach normal operating temperature sooner.

**Note:** *If the heater is in the process of stopping, excess fuel in the heater burns out and there is some heat, exhaust and noise.*

## Parking Heater Information Messages

Message	Action
Park heater not started Low fuel level	Displays if the parking heater fails to operate due to low fuel level. Refuel as soon as possible.

## Switching Continue Heat On

When you switch the ignition off, the heater starts or continues running if conditions permit for up to 30 minutes.

**Note:** *You can use this mode to maintain a warm cabin after you switch the ignition off. After the heater completes this mode, the check box in the information display resets to unchecked.*

**To switch continue heat on, use the information display controls on the steering wheel to select the following:**

Menu Item	Action
Settings	Press the menu button.
Vehicle settings	Press the <b>OK</b> button.
Park heater	Press the <b>OK</b> button.
Continue heat	Press the <b>OK</b> button.

# Climate Control

## Setting the Timer

**The system has three different modes, that you can set in the information display.**

Timer Mode	Description
Once	Allows you to set one heating cycle for a specific day. If conditions permit, the heater starts up to 40 minutes prior to the set date and time. <sup>1</sup>
Time one	Allows you to program a heating cycle for each day of the week. The time remains stored and the system warms up your vehicle prior to the programmed departure times.
Time two	Allows you to program a second heating cycle for each day of the week. The time remains stored and the system warms up your vehicle prior to the programmed departure times.

<sup>1</sup>You must set the day and time for this mode before you check the box in the information display.

**Note:** *The time and date on your vehicle clock must be correctly set.*

**To set a timer mode, use the information display controls on the steering wheel to select the following:**

Menu Item	Action
Settings	Press the menu button.
Vehicle settings	Press the <b>OK</b> button.
Park heater	Press the <b>OK</b> button.
Heater programming	Press the <b>OK</b> button.
Activate	Press the <b>OK</b> button.
Once	Press the <b>OK</b> button.
Activate	Press the <b>OK</b> button.
Time one	Press the <b>OK</b> button.
Activate	Press the <b>OK</b> button.
Time two	Press the <b>OK</b> button.
Activate	Press the <b>OK</b> button.

# Climate Control

## REMOTE START

### About Remote Start

The system allows you to remotely start the engine using the FordPass app.

The system can also adjust the interior temperature according to the settings that you chose.

**Note:** All other vehicle systems remain off when you have remotely started the engine.

**Note:** The vehicle remains secured when you have remotely started the engine. A valid key must be inside your vehicle to switch the ignition on and drive your vehicle.

### Remote Start Limitations

Remote start does not work if:

- The alarm horn is sounding.
- The hood is open.
- The transmission is not in park (P).

### Setting Remote Start to Active

1. Using the information display controls on the steering wheel, select **Settings**.
2. Select **Vehicle settings**.
3. Select **Remote start**.
4. Switch **System** on.

**Note:** You have to enable the modem using the FordPass app to use remote start. See **Enabling the Modem Using FordPass** (page 296).

### Remotely Starting the Engine



Use the FordPass app to start the engine.

**Note:** The direction indicators flash twice.

**Note:** The parking lamps turn on when the engine is running.

**Note:** The horn sounds if the system fails to start.

**Note:** You must switch on the ignition before driving your vehicle.

### Remotely Stopping the Engine

Use the FordPass app to stop the engine.

### Remote Start Settings

Use the information display to adjust the remote start settings.

**Note:** You cannot adjust the climate control settings when you have remotely started the engine.

**Note:** When you switch the ignition on, the climate control system returns to the last used settings.

### Switching Auto On

1. Using the information display controls on the steering wheel, select **Settings**.
2. Select **Vehicle settings**.
3. Select **Remote start**.
4. Select **Climate control**.
5. Switch **Auto** on.

**Note:** If you switch **Auto** on, the system attempts to heat or cool the interior to 22°C (72°F).

**Note:** The heated windshield, heated rear window and heated seats could turn on in cold weather.

### Switching Last settings On

1. Using the information display controls on the steering wheel, select **Settings**.
2. Select **Vehicle settings**.
3. Select **Remote start**.

# Climate Control

---

4. Select **Climate control**.
5. Switch **Last settings** on.

**Note:** *If you switch **Last settings** on, the system remembers the last used settings.*

## Switching the Heated Seats Settings On

1. Using the information display controls on the steering wheel, select **Settings**.
2. Select **Vehicle settings**.
3. Select **Remote start**.
4. Select **Seats**.
5. Switch **Auto** on.

**Note:** *If you switch the heated seats settings on, the heated seats turn on during cold weather.*

## Setting the Duration

You can set a duration for the engine to run.

**Note:** *Wait a few seconds before remotely starting the engine after the engine stops running.*

1. Using the information display controls on the steering wheel, select **Settings**.
2. Select **Vehicle settings**.
3. Select **Remote start**.
4. Select **Duration**.

# Seats

## SITTING IN THE CORRECT POSITION



**WARNING:** Do not recline the seatback too far as this can cause the occupant to slide under the seatbelt, resulting in serious injury in the event of a collision.



**WARNING:** Always sit upright against your seatback with your feet on the floor.



**WARNING:** Do not place objects higher than the top of the seat backrest. Failure to follow this instruction could result in personal injury or death in the event of a sudden stop or crash.

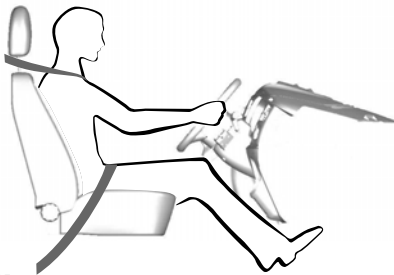

E68595

When you use them properly, the seat, head restraint, seatbelt and airbags will provide optimum protection in the event of a crash.

We recommend that you follow these guidelines:

- Sit in an upright position with the base of your spine as far back as possible.
- Do not recline the seat backrest so that your torso is more than 30° from the upright position.
- Adjust the head restraint so that the top of it is level with the top of your head and as far forward as possible. Make sure that you remain comfortable.
- Keep sufficient distance between yourself and the steering wheel. We recommend a minimum of 25 cm (10 in) between your breastbone and the airbag cover.
- Hold the steering wheel with your arms slightly bent.
- Bend your legs slightly so that you can press the pedals fully.
- Position the shoulder strap of the seatbelt over the center of your shoulder and position the lap strap tightly across your hips.

Make sure that your driving position is comfortable and that you can maintain full control of your vehicle.

## HEAD RESTRAINTS



**WARNING:** Fully adjust the head restraint before you sit in or operate your vehicle. This will help minimize the risk of neck injury in the event of a crash. Do not adjust the head restraint when your vehicle is moving.

### Adjusting the Head Restraints

Adjust the head restraint so that the top of it is level with the top of your head.

# Seats

## Raising the Head Restraints

1. Pull the head restraint upward.
2. Make sure that the head restraint locks into place.

## Lowering the Head Restraints

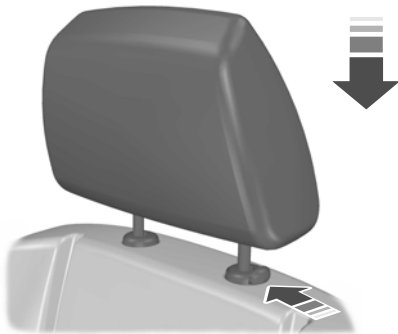

E289088

1. Press and hold the locking button.
2. Push the head restraint downward.
3. Make sure that the head restraint locks into place.

## Removing the Head Restraints

### Front Head Restraints

1. Recline the seat backrest so that there is enough room for you to remove the head restraint.

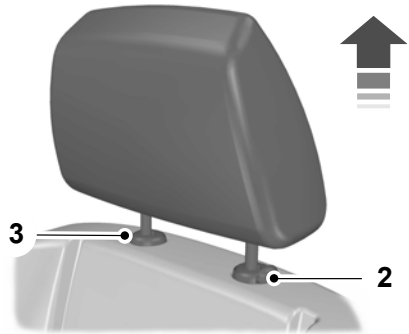

E288933

2. Press and hold the locking button.
3. Use a suitable tool, for example a screwdriver, to release the retaining clip.

### Rear Head Restraints

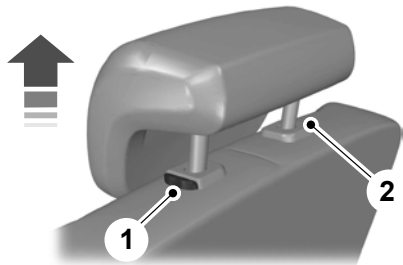

E288934

1. Press and hold the locking button.
2. Use a suitable tool, for example a screwdriver, to release the retaining clip.

# Seats

## MANUAL SEATS

 **WARNING:** Do not adjust the driver seat when your vehicle is moving.

 **WARNING:** Do not place cargo or any objects behind the seat backrest before returning it to the original position. Pull on the seat backrest to make sure that it has fully latched after returning the seat backrest to its original position. An unlatched seat may become dangerous if you stop suddenly or have a crash.

### Moving the Seat Backward and Forward

 **WARNING:** Make sure the seat fully locks into place by rocking it backward and forward. Not securing the seat into the locked position can be dangerous in a crash and could cause serious personal injury or death.



E130249

### Adjusting the Seat Backrest

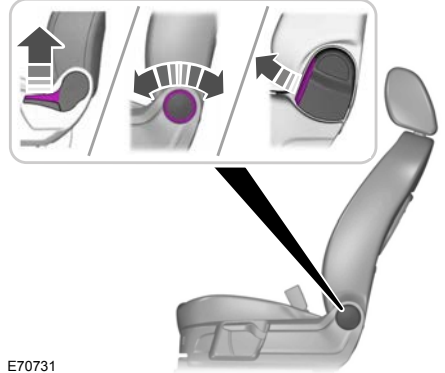

E70731

### Adjusting the Seat Height (If Equipped)

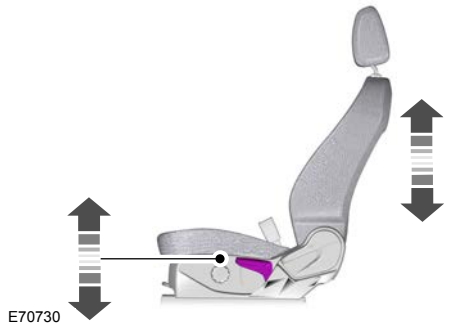

E70730

# Seats

## Adjusting the Lumbar Support (If Equipped)



E142199

## Single Passenger Seat (If Equipped)



**WARNING:** When folding the seat backrest down, take care not to get your fingers caught in the mechanism.



**WARNING:** Do not sit in a seat facing a folded seat. Failure to follow this instruction could result in personal injury in the event of a sudden stop or crash.

## Folding the Seat Backrest



E275437

1. Move the seat fully backward.

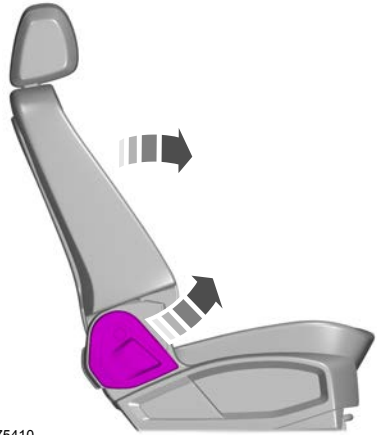

E275410

2. Fold the seat backrest fully forward.



E275411

3. Fully lower the head restraint.

# Seats

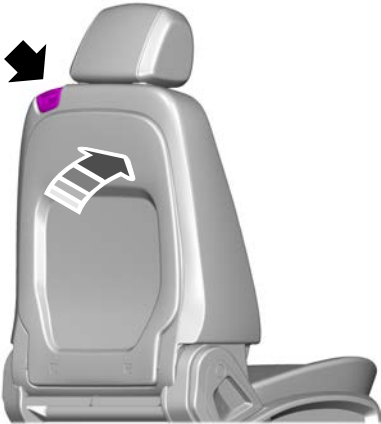

E275412

4. Pull the lever.
5. Push the seat backrest forward.

## Dual Passenger Seat (If Equipped)



**WARNING:** When folding the seat backrest down, take care not to get your fingers caught in the mechanism.

## Folding the Center Seat Backrest Down



E168479

1. Pull the strap.
2. Fold the seat backrest down.

## Folding the Center Seat Cushion Up



E168478

# Seats

## Folding the Outer Seat Down



E167550

1. Pull the strap.
2. Fold the seat backrest and seat cushion forward to the lower position.

**Note:** The seat cushion automatically folds with the seat backrest.

## Folding the Outer Seat Cushion Up



**WARNING:** Make sure that you fold the seat cushion down before you drive away.



E168476

1. Pull the release lever.
2. Fold the seat cushion up until it locks into place.

## Folding the Outer Seat Cushion Down



E168477

1. Pull the release lever.

# Seats

2. Fold the seat cushion down until it locks into place.

## REAR SEATS - SHORT WHEELBASE



**WARNING:** Do not use the bench seats as a bed when your vehicle is moving. Failure to follow this warning could result in serious personal injury or death.



**WARNING:** When folding or unfolding the seats, take care not to get your fingers caught between the seat backrest and seat frame. Failure to follow this warning could result in serious personal injury.



**WARNING:** Do not sit in a seat facing a folded seat. Failure to follow this instruction could result in personal injury in the event of a sudden stop or crash.



**WARNING:** Do not place any objects on a folded seat. Hard objects may become projectiles in a crash or sudden stop, which may increase the risk of serious personal injury.

## Second Row Seats

### Folding the Seat

1. Fully lower the head restraints. See **Head Restraints** (page 105).



E271963

2. Pull the lever on the top of the seat.
3. Fold the seat backrest forward.

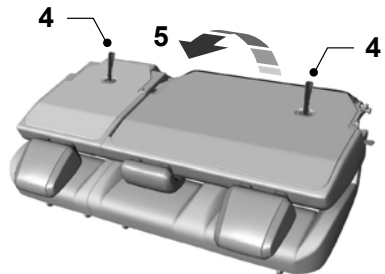

E271964

4. Pull the strap on the rear of the seat backrest.
5. Raise the seat.

# Seats

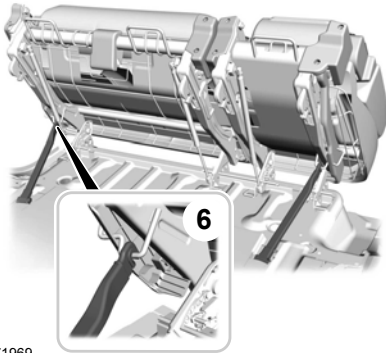

E271969

6. Lift the support rod and connect it to the seat frame. This prevents the seat from falling backward.

**Note:** *Rear row occupants can sit next to a seat in the same row that has the seat backrest in the folded position, but not when the seat is in the tilted position.*

## Unfolding the Seat

1. Disconnect the support rod from the seat frame.
2. Unfold the seat backward and lock into position.
3. Unfold the seat backrest backward and lock into position.

## Third Row Seats

### Moving the Seat Backward and Forward



**WARNING:** Make sure the seat fully locks into place by rocking it backward and forward. Not securing the seat into the locked position can be dangerous in a crash and could cause serious personal injury or death.



E271965

## Folding the Seat Backrest

1. Fully lower the head restraints. See **Head Restraints** (page 105).
2. Fully move the seat backward.

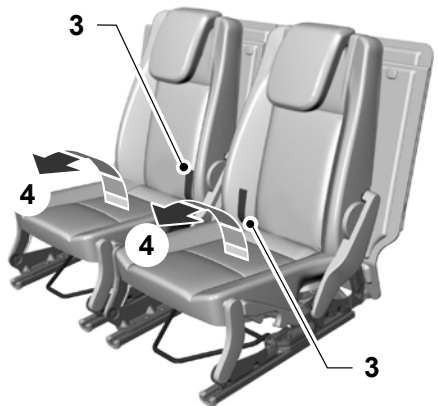

E271966

# Seats

3. Pull the strap on the rear of the seat cushion.
4. Fold the seat cushion forward.

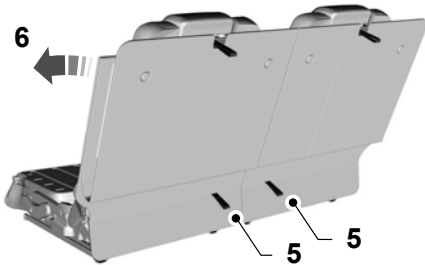

E272026

5. Pull the strap on the rear of the seat backrest.
6. Fold the seat backrest forward.

**Note:** Rear row occupants can sit next to a seat in the same row that has the seat backrest in the folded position, but not when the seat is in the tilted position.

## Unfolding the Seat Backrest

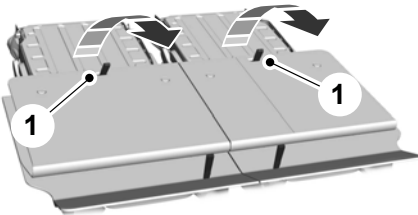

E167644

1. Pull the strap on the rear of the seat backrest.
2. Unfold the seat backrest backward and lock into position.
3. Unfold the seat cushion backward and lock into position.

## Creating a Level Load Floor



E167645

The carpeted cover is held in position by magnets. Fold the carpeted cover forward to cover up the folded seats.

## REAR SEATS - LONG WHEELBASE



**WARNING:** When folding or unfolding the seats, take care not to get your fingers caught between the seat backrest and seat frame. Failure to follow this warning could result in serious personal injury.



**WARNING:** Do not use the bench seats as a bed when your vehicle is moving. Failure to follow this warning could result in serious personal injury or death.



**WARNING:** Do not place any objects on a folded seat. Hard objects may become projectiles in a crash or sudden stop, which may increase the risk of serious personal injury.

# Seats



**WARNING:** Do not sit in a seat facing a folded seat. Failure to follow this instruction could result in personal injury in the event of a sudden stop or crash.

## Second Row Seats

### Folding the Seat

1. Fully lower the head restraints. See **Head Restraints** (page 105).

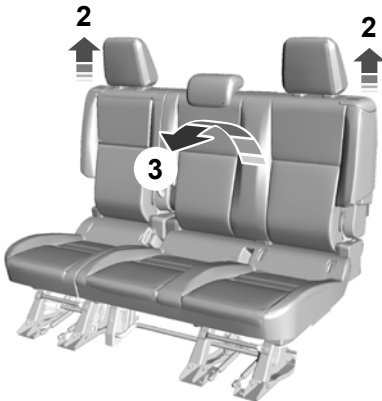

E271960

2. Pull the lever on the top of the seat.
3. Fold the seat backrest forward, then push down on the center of the seat backrest to lock the latches.

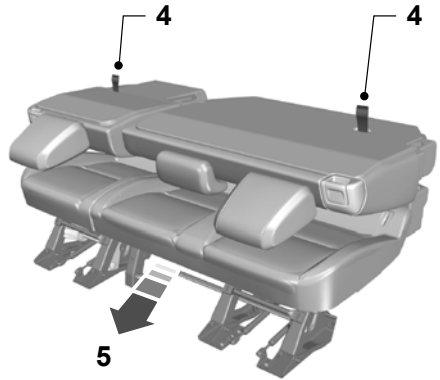

E271961

4. Pull the strap on the rear of the seat backrest.
5. Move the seat forward to the lowered position, then push down on the center of the seat backrest to lock the latches.

**Note:** A distinct click sounds when the seat is locked in the lowered position.

**Note:** Rear row occupants can sit next to a seat in the same row that has the seat backrest in the folded position, but not when the seat is in the tilted position.

# Seats

## Unfolding the Seat

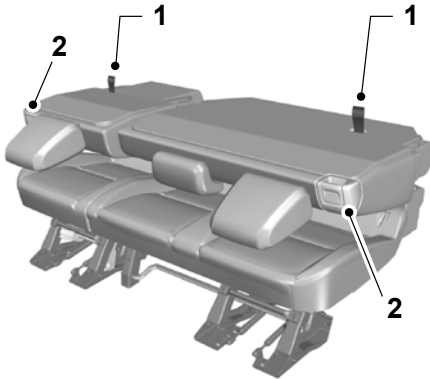

E271962

1. Pull the strap on the rear of the seat backrest, lift the seat and push down to lock into position.
2. Pull the lever on the top of the seat, unfold the seat backrest backward and lock into position. Push down in the center of the seat to make sure the latches are locked.

**Note:** You cannot unfold the seat backrest if a red flag is visible on the large strap. Make sure the seat is locked and the red flag is not visible.

## Third Row Seats

### Moving the Seat Backward and Forward



**WARNING:** Make sure the seat fully locks into place by rocking it backward and forward. Not securing the seat into the locked position can be dangerous in a crash and could cause serious personal injury or death.



E271965

### Folding the Seat Backrest

1. Fully lower the head restraints. See **Head Restraints** (page 105).
2. Fully move the seat backward.

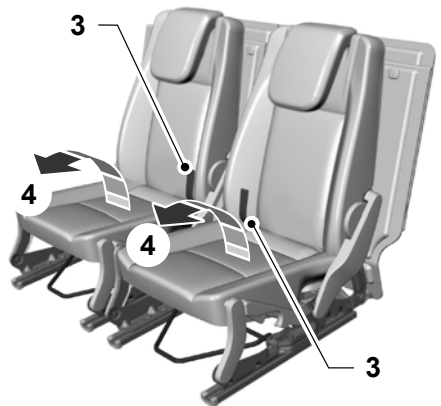

E271966

# Seats

3. Pull the strap on the rear of the seat cushion.
4. Fold the seat cushion forward.

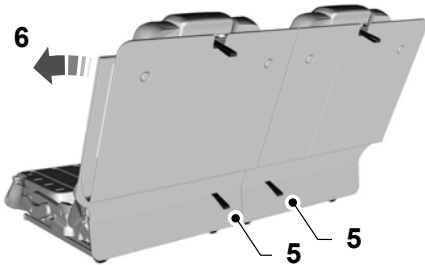

E272026

5. Pull the strap on the rear of the seat backrest.
6. Fold the seat backrest forward.

**Note:** Rear row occupants can sit next to a seat in the same row that has the seat backrest in the folded position, but not when the seat is in the tilted position.

## Unfolding the Seat Backrest

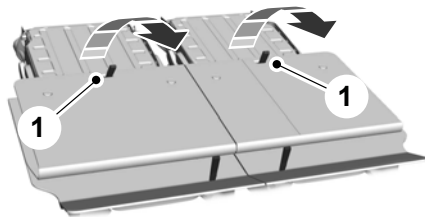

E167644

1. Pull the strap on the rear of the seat backrest.
2. Unfold the seat backrest backward and lock into position.
3. Unfold the seat cushion backward and lock into position.

## Creating a Level Load Floor



E167645

The carpeted cover is held in position by magnets. Fold the carpeted cover forward to cover up the folded seats.

## HEATED SEATS (IF EQUIPPED)



**WARNING:** Use caution when using the heated seat if you are unable to feel pain to your skin because of advanced age, chronic illness, diabetes, spinal cord injury, medication, alcohol use, exhaustion or other physical conditions. The heated seat could cause burns even at low temperatures, especially if used for long periods of time. Failure to follow this instruction could result in personal injury.



**WARNING:** Do not place anything on the seat that blocks the heat, for example a seat cover or a cushion. This could cause the seat to overheat. Failure to follow this instruction could result in personal injury.

# Seats

---



**WARNING:** Do not poke sharp objects into the seat cushion or seat backrest. This could damage the heated seat element and cause it to overheat. Failure to follow this instruction could result in personal injury.

Do not switch the heated seat on if the seat is wet.

The heated seat button is on the climate control assembly.



Repeatedly press the button to adjust the temperature.

# Auxiliary Power Points

## 12 Volt DC Power Point



**WARNING:** Do not plug optional electrical accessories into the cigar lighter socket. Incorrect use of the cigar lighter can cause damage not covered by the vehicle warranty, and can result in fire or serious injury.



**WARNING:** Do not use a power point for operating a cigar lighter. Incorrect use of the power points can cause damage not covered by the vehicle warranty, and can result in fire or serious injury.

Do not hang any accessory from the accessory plug.

Do not use the power point over the vehicle capacity of 12 volt DC 180 watts or a fuse will blow.

Keep the power point caps closed when not in use.

Do not insert objects other than an accessory plug into the power point.

You can use the power point for up to 20 minutes after you switch the ignition off.

**Note:** When you switch the ignition on, you can use the socket to power 12 volt appliances with a maximum current rating of 15 amps.

Run the vehicle for full capacity use of the power point.

To prevent the battery from running out of charge:

- Do not use the power point longer than necessary when the vehicle is not running.
- Do not leave devices plugged in overnight or when you park your vehicle for extended periods.

Power points may be in the following locations:

- Front of the floor console.
- Rear of the floor console.
- Right hand side of the luggage compartment.
- Instrument panel cluster storage compartment.

## CIGAR LIGHTER



**WARNING:** Do not plug optional electrical accessories into the cigar lighter socket. Incorrect use of the cigar lighter can cause damage not covered by the vehicle warranty, and can result in fire or serious injury.

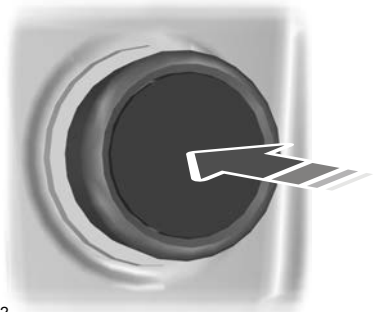

E103382

Press the element in to use the cigar lighter. It pops out after a short period of time.

Do not hold the cigar lighter element pressed in.

**Note:** If the power supply does not work after you switch the ignition off, switch the ignition on.

## Auxiliary Power Points

**Note:** If you use the socket when the engine is not running, the battery may run out of charge.

**Note:** When you switch the ignition on, you can use the socket to power 12 volt appliances with a maximum current rating of 15 amps.

### WIRELESS ACCESSORY CHARGING



**WARNING:** Wireless charging devices can affect the operation of implanted medical devices, including cardiac pacemakers. If you have any implanted medical devices, we recommend that you consult with your physician.

The system supports one wireless charging compatible device on the charging area.

**Note:** Devices without built-in Qi standards for wireless charging require an additional Qi receiver or sleeve.

Make sure the charging area is clean before charging a device.

Do not place items with a magnetic strip, for example passports, parking tickets or credit cards near the charging area when charging a device. This could damage the magnetic strip.

Do not place metal objects, for example remote controls, coins or keys on or near the charging area when charging a device. Metal objects may heat up and degrade the charging performance.



The charging area is below the audio unit.

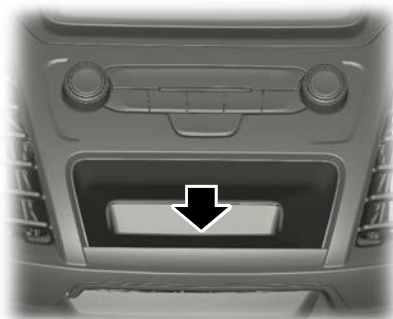

E270527

Place the device with the charging side down to begin charging. The charging stops after your device reaches a full charge.

**Note:** Charging time and temperature are dependent on the device used. The system stops charging the device if it reaches a high temperature.

# Storage Compartments

## CUP HOLDERS

 **WARNING:** Do not place hot drinks in the cup holders when your vehicle is moving.

 **WARNING:** Make sure that cups placed in the holders do not obstruct your vision while driving.

## OVERHEAD CONSOLE

 **WARNING:** Do not place heavy objects in the storage compartment. Heavy objects may become projectiles in a crash or sudden stop, which may increase the risk of serious injury.

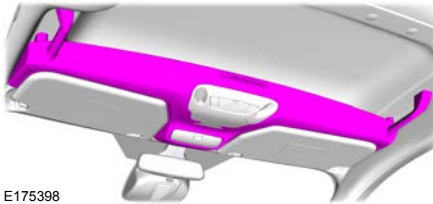

## Rear Door Storage Compartment (If Equipped)



## FOLDING TRAY

 **WARNING:** Do not use the trays when your vehicle is moving. Make sure that you secure the trays in the lowered position before setting off.



# Storage Compartments

---

## UNDER SEAT STORAGE



E289210

## INSTRUMENT PANEL STORAGE COMPARTMENT

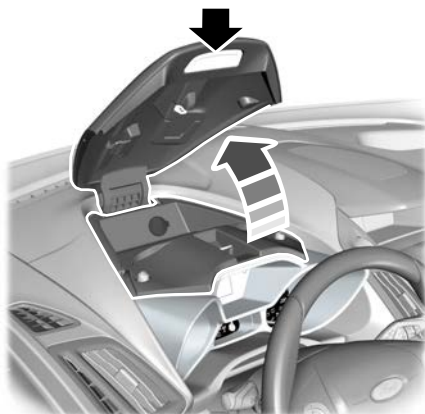

E210263

# Starting and Stopping the Engine

## GENERAL INFORMATION



**WARNING:** Extended idling at high engine speeds can produce very high temperatures in the engine and exhaust system, creating the risk of fire or other damage.



**WARNING:** Do not park, idle or drive your vehicle on dry grass or other dry ground cover. The emission system heats up the engine compartment and exhaust system, creating the risk of fire.



**WARNING:** Do not start the engine in a closed garage or in other enclosed areas. Exhaust fumes can be toxic. Always open the garage door before you start the engine.



**WARNING:** Exhaust leaks may result in entry of harmful and potentially lethal fumes into the passenger compartment. If you smell exhaust fumes inside your vehicle, have your vehicle inspected immediately. Do not drive if you smell exhaust fumes.

If you disconnect the battery, your vehicle may exhibit some unusual driving characteristics for approximately 8 km (5 mi) after you reconnect it. This is because the engine management system must realign itself with the engine. You can disregard any unusual driving characteristics during this period.

The powertrain control system meets all Canadian interference-causing equipment standard requirements regulating the impulse electrical field or radio noise.

When you start the engine, avoid pressing the accelerator pedal before and during operation. Only use the accelerator pedal when you have difficulty starting the engine.

## IGNITION SWITCH



E247596

**Note:** Make sure the key is clean before inserting it into any lock cylinder.

**Note:** Do not leave the key in the ignition for an extended period of time when the engine is not running. This is to prevent the vehicle battery from losing charge.

### Switching the Ignition Off

Turn the key to position **0**.

### Switching the Ignition to Accessory Mode

Turn the key to position **I**. Electrical accessories, for example the radio, operate without the engine running.

# Starting and Stopping the Engine

## Switching the Ignition On

Turn the key to position **II**. All electrical circuits and accessories are operational and the warning lamps and indicators illuminate.

## Starting the Engine

Turn the key to position **III**. Release the key when the engine starts.

## PUSH BUTTON IGNITION SWITCH

### Switching the Ignition On to Accessory Mode



E144447

Press the push button ignition switch once without your foot on the brake or clutch pedal. It is on the instrument panel near the steering wheel. All electrical circuits and accessories are operational and the warning lamps and indicators illuminate.

Press the push button ignition switch again without your foot on the brake or clutch pedal to switch the ignition off.

**Note:** *The system may not function if the passive key is close to metal objects or electronic devices, for example keys or a cell phone.*

**Note:** *The ignition turns off if you leave your vehicle unattended. This is to prevent the vehicle battery from losing charge.*

**Note:** *A valid passive key must be inside your vehicle to switch the ignition on and start the engine.*

### Starting The Engine - Vehicles with Manual Transmission (If Equipped)

1. Fully press the clutch pedal.
2. Press the push button ignition switch.

**Note:** *If you release the clutch pedal during engine starting, the engine stops cranking.*

### Starting The Engine - Vehicles with Automatic Transmission (If Equipped)

1. Fully press the brake pedal.
2. Shift into park (P).
3. Press the push button ignition switch.

**Note:** *If you release the brake pedal during engine starting, the engine stops cranking.*

### Vehicles with a Diesel Engine (If Equipped)

**Note:** *The engine does not crank until the glow plug indicator turns off. This may take several seconds in extremely cold conditions.*

### Failure to Start - Vehicles with Manual Transmission (If Equipped)

The system does not function if:

- The passive key frequencies are jammed.
- The key battery has no charge.

If you are unable to start the engine, do the following:

1. Insert the passive key into the backup position. See **Passive Key Backup Position** (page 48).

# Starting and Stopping the Engine

2. With the passive key in this position, you can use the push button ignition switch to switch the ignition on and start the engine.

If the engine does not crank after you fully press the clutch pedal and press the push button ignition switch, do the following:

1. Fully press the clutch pedal and the brake pedal.
2. Press the push button ignition switch.

## Stopping the Engine When Your Vehicle is Stationary - Vehicles with Manual Transmission (If Equipped)

Press the push button ignition switch.

**Note:** *The ignition, all electrical circuits and all warning lamps and indicators turn off.*

## Stopping the Engine When Your Vehicle is Stationary - Vehicles with Automatic Transmission (If Equipped)

1. Fully press the brake pedal.
2. Shift into park (P).
3. Press the push button ignition switch.

**Note:** *The ignition, all electrical circuits and all warning lamps and indicators turn off.*

## Stopping the Engine When Your Vehicle is Moving - Vehicles with Manual Transmission (If Equipped)



**WARNING:** Switching off the engine when your vehicle is still moving results in a significant decrease in braking assistance. Higher effort is required to apply the brakes and to stop your vehicle. A significant decrease in steering assistance could also occur. The steering does not lock, but higher effort

could be required to steer your vehicle. When you switch the ignition off, some electrical circuits, for example airbags, also turn off. If you unintentionally switch the ignition off, shift into neutral (N) and restart the engine.

1. Press and hold the push button ignition switch until the engine stops, or press it three times within two seconds.
2. Shift into neutral and use the brakes to bring your vehicle to a safe stop.
3. Press the push button ignition switch.

## Stopping the Engine When Your Vehicle is Moving - Vehicles with Automatic Transmission (If Equipped)



**WARNING:** Switching off the engine when your vehicle is still moving results in a significant decrease in braking assistance. Higher effort is required to apply the brakes and to stop your vehicle. A significant decrease in steering assistance could also occur. The steering does not lock, but higher effort could be required to steer your vehicle. When you switch the ignition off, some electrical circuits, for example airbags, also turn off. If you unintentionally switch the ignition off, shift into neutral (N) and restart the engine.

1. Press and hold the push button ignition switch until the engine stops, or press it three times within two seconds.
2. Shift into neutral and use the brakes to bring your vehicle to a safe stop.
3. Shift into park (P).
4. Press the push button ignition switch.

# Starting and Stopping the Engine

## Fast Restart

The system allows you to start the engine within 10 seconds of switching it off, even if it does not detect a valid passive key.

Within 10 seconds of switching the engine off, fully press the brake or clutch pedal and press the push button ignition switch. After 10 seconds, you can no longer start the engine if the system does not detect a valid passive key.

When you start the engine, it remains running until you press the push button ignition switch, even if your vehicle does not detect a valid passive key. If you open and close a door when the engine is running, the system searches for a valid passive key.

## Starting System Information Messages

Message	Action
Full accessory power active	Displays if you switch the ignition on and do not start the engine.
Press brake to start	Displays when you start the engine as a reminder to fully press the brake pedal.
Press clutch to start	Displays when you start the engine as a reminder to fully press the clutch pedal.
Press brake and clutch to start	Displays when you start the engine as a reminder to fully press the brake and clutch pedals.
Cranking time exceeded	Displays if the engine fails to start.
No key detected	Displays if the system does not detect a valid passive key.
Starting system malfunction	Displays if you are unable to start the engine with a correctly coded key. The system has detected a fault that requires service. Have your vehicle checked as soon as possible.
Restart now or key is needed	Displays for 10 seconds if you switch the engine off and the system does not detect a valid passive key. After 10 seconds, you can no longer start the engine if the system does not detect a valid passive key.

## Key Outside Vehicle Audible Warning

Sounds when you remove the passive key from your vehicle and the engine is running.

# Starting and Stopping the Engine

## STEERING WHEEL LOCK - VEHICLES WITHOUT: PUSH BUTTON START



**WARNING:** Always check that the steering is unlocked before attempting to move your vehicle.

### Locking the Steering Wheel

1. Remove the key from the ignition.
2. Slightly rotate the steering wheel to engage the lock.

### Unlocking the Steering Wheel

1. Insert the key in the ignition.
2. Turn the key to position **I**.

**Note:** You may have to slightly rotate the steering wheel to assist unlocking it.

## STEERING WHEEL LOCK - VEHICLES WITH: PUSH BUTTON START

Your vehicle has an electronically controlled steering wheel lock that automatically operates.

The steering wheel will lock shortly after you have parked your vehicle and the passive key is outside it or when you lock your vehicle.

**Note:** The steering wheel will not lock when the ignition is on or when your vehicle is moving.

### Unlocking the Steering Wheel

The steering wheel unlocks when the system detects a valid passive key inside your vehicle. If the steering wheel relocks, switch the ignition on to unlock it.

**Note:** You may have to slightly rotate the steering wheel to assist unlocking it.

## STARTING A GASOLINE ENGINE - AUTOMATIC TRANSMISSION

The speed at which the engine idles immediately after starting is optimized to minimize vehicle emissions and maximize cabin comfort and fuel economy.

**Note:** You can only attempt to start the engine for a limited amount of time before the starting system temporarily disables. If you exceed the starting time limit, a message may appear and you cannot attempt to start the engine for at least 15 minutes.

Before starting your vehicle, check the following:

- Make sure the headlamps and electrical accessories are off.
- Make sure the parking brake is on.
- Make sure the transmission is in park (P).

### Vehicles with an Ignition Key

1. Fully press the brake pedal.

**Note:** Do not touch the accelerator pedal.

2. Turn the key to position **III**.

**Note:** The engine may continue cranking for up to 15 seconds or until it starts.

**Note:** The engine takes longer to start at lower temperatures. It may crank for several seconds when very cold.

### Vehicles with a Push Button Ignition Switch

See **Push Button Ignition Switch** (page 123).

# Starting and Stopping the Engine

## Failure to Start

If you cannot start the engine after 3 attempts, wait 10 seconds and do the following:

### Vehicles with an Ignition Key

1. Fully press the brake pedal.
2. Apply the parking brake.
3. Shift into park (P).
4. Fully press the accelerator pedal and hold it there.
5. Turn the key to position **III** and wait until the engine stops.
6. Release the accelerator pedal.
7. Start the engine.

### Vehicles with a Push Button Ignition Switch

See **Push Button Ignition Switch** (page 123).

## Switching the Automatic Engine Shutdown On or Off

**To switch the automatic engine shutdown on or off, use the information display controls on the steering wheel to select the following:**

Menu Item	Action
Settings	Press the menu button.
Vehicle settings	Press the <b>OK</b> button.
Auto engine off	Press the <b>OK</b> button.

**Note:** *You cannot permanently switch off the automatic shutdown. If you switch it off, it turns on each time you switch the ignition on.*

## Automatic Engine Shutdown

For vehicles with a push button ignition switch, the engine shuts down if it has been idling for an extended period. The ignition also turns off to save battery power. Before your vehicle shuts down, a message appears in the information display showing a timer counting down. If you do not intervene within 30 seconds, your vehicle shuts down. Another message appears in the information display to inform you that your vehicle has shut down to save fuel. Start your vehicle as normal.

### Automatic Engine Shutdown Override

You can stop the shutdown, or reset the timer, at any point before the 30-second countdown has expired by doing any of the following:

- Pressing the brake or accelerator pedal.
- Switching off the automatic engine shutdown in the information display.
- Pressing the **OK** or **RESET** button during the 30-second countdown.

## Stopping the Engine When Your Vehicle is Stationary

### Vehicles with an Ignition Key

1. Shift into park (P).
2. Turn the key to position **0**.
3. Apply the parking brake.

# Starting and Stopping the Engine

## Vehicles with a Push Button Ignition Switch

See **Push Button Ignition Switch** (page 123).

## Stopping the Engine When Your Vehicle is Moving



**WARNING:** Switching off the engine when your vehicle is still moving results in a significant decrease in braking assistance. Higher effort is required to apply the brakes and to stop your vehicle. A significant decrease in steering assistance could also occur. The steering does not lock, but higher effort could be required to steer your vehicle. When you switch the ignition off, some electrical circuits, for example airbags, also turn off. If you unintentionally switch the ignition off, shift into neutral (N) and restart the engine.

## Vehicles with an Ignition Key

1. Shift into neutral and use the brakes to bring your vehicle to a safe stop.
2. Shift into park (P).
3. Turn the key to position **0**.
4. Apply the parking brake.

## Vehicles with a Push Button Ignition Switch

See **Push Button Ignition Switch** (page 123).

## Guarding Against Exhaust Fumes



**WARNING:** Exhaust leaks may result in entry of harmful and potentially lethal fumes into the passenger compartment. If you smell exhaust fumes inside your vehicle, have your vehicle inspected immediately. Do not drive if you smell exhaust fumes.

## Important Ventilating Information

If you stop your vehicle and then leave the engine idling for long periods, we recommend that you do one of the following:

- Open the windows at least 3 cm (1 in).
- Set your climate control to outside air.

## Engine Warning Lamps



Malfunction Indicator Lamp  
Check Engine

If it illuminates when the engine is running this indicates a malfunction. The On Board Diagnostics system has detected a malfunction of the vehicle emission control system.

If it flashes, engine misfire may be occurring. Increased exhaust gas temperatures could damage the catalytic converter or other vehicle components. Avoid heavy acceleration and deceleration and have your vehicle immediately serviced.



Powertrain Warning Lamp

If it illuminates when the engine is running this indicates a malfunction. If it flashes when you are driving, immediately reduce the vehicle speed. Avoid heavy acceleration and deceleration and have your vehicle immediately serviced.

# Starting and Stopping the Engine

If both lamps illuminate when the engine is running, stop your vehicle as soon as it is safe to do so. Continuing to drive your vehicle may cause reduced power or the

engine to stop. Switch the ignition off and attempt to restart the engine. Have your vehicle immediately checked.

## Starting System Information Messages

Message	Action
Full accessory power active	Displays if you switch the ignition on and do not start the engine.
Cranking time exceeded	Displays if you exceed the starting time limit. You cannot attempt to start the engine for 15 minutes. If you cannot start the engine after 15 minutes passes, have your vehicle immediately checked.
Starting system malfunction	Displays if you are unable to start your vehicle with a correctly coded key. The system has detected a fault that requires service. Have your vehicle checked as soon as possible.

## STARTING A GASOLINE ENGINE - MANUAL TRANSMISSION

The speed at which the engine idles immediately after starting is optimized to minimize vehicle emissions and maximize cabin comfort and fuel economy.

**Note:** You can only attempt to start the engine for a limited amount of time before the starting system temporarily disables. If you exceed the starting time limit, a message may appear and you cannot attempt to start the engine for at least 15 minutes.

Before starting your vehicle, check the following:

- Make sure the headlamps and electrical accessories are off.
- Make sure the parking brake is on.
- Make sure the transmission is in neutral.

## Vehicles with an Ignition Key

1. Fully press the clutch pedal.  
**Note:** Do not touch the accelerator pedal.
2. Turn the key to position **III**.

**Note:** The engine may continue cranking for up to 15 seconds or until it starts.

**Note:** The engine takes longer to start at lower temperatures. It may crank for several seconds when very cold.

## Vehicles with a Push Button Ignition Switch

See **Push Button Ignition Switch** (page 123).

## Failure to Start

If you cannot start the engine after 3 attempts, wait 10 seconds and do the following:

## Vehicles with an Ignition Key

1. Fully press the clutch pedal.
2. Apply the parking brake.

# Starting and Stopping the Engine

3. Shift into neutral.
4. Fully press the accelerator pedal and hold it there.
5. Turn the key to position **III** and wait until the engine stops.
6. Release the accelerator pedal.
7. Start the engine.

## Vehicles with a Push Button Ignition Switch

See **Push Button Ignition Switch** (page 123).

## Automatic Engine Shutdown

For vehicles with a push button ignition switch, the engine shuts down if it has been idling for an extended period. The ignition also turns off to save battery power. Before your vehicle shuts down, a message appears in the information display showing

## Switching the Automatic Engine Shutdown On or Off

**To switch the automatic engine shutdown on or off, use the information display controls on the steering wheel to select the following:**

Menu Item	Action
Settings	Press the menu button.
Vehicle settings	Press the <b>OK</b> button.
Auto engine off	Press the <b>OK</b> button.

**Note:** *You cannot permanently switch off the automatic shutdown. If you switch it off, it turns on each time you switch the ignition on.*

## Stopping the Engine When Your Vehicle is Stationary

### Vehicles with an Ignition Key

1. Shift into neutral.
2. Turn the key to position **O**.

a timer counting down. If you do not intervene within 30 seconds, your vehicle shuts down. Another message appears in the information display to inform you that your vehicle has shut down to save fuel. Start your vehicle as normal.

## Automatic Engine Shutdown Override

You can stop the shutdown, or reset the timer, at any point before the 30-second countdown has expired by doing any of the following:

- Pressing the brake or accelerator pedal.
- Switching off the automatic engine shutdown in the information display.
- Pressing the **OK** or **RESET** button during the 30-second countdown.

3. Apply the parking brake.

## Vehicles with a Push Button Ignition Switch

See **Push Button Ignition Switch** (page 123).

# Starting and Stopping the Engine

## Stopping the Engine When Your Vehicle is Moving



**WARNING:** Switching off the engine when your vehicle is still moving results in a significant decrease in braking assistance. Higher effort is required to apply the brakes and to stop your vehicle. A significant decrease in steering assistance could also occur. The steering does not lock, but higher effort could be required to steer your vehicle. When you switch the ignition off, some electrical circuits, for example airbags, also turn off. If you unintentionally switch the ignition off, shift into neutral (N) and restart the engine.

## Vehicles with an Ignition Key

1. Shift into neutral and use the brakes to bring your vehicle to a safe stop.
2. Turn the key to position **0**.
3. Apply the parking brake.

## Vehicles with a Push Button Ignition Switch

See **Push Button Ignition Switch** (page 123).

## Guarding Against Exhaust Fumes



**WARNING:** Exhaust leaks may result in entry of harmful and potentially lethal fumes into the passenger compartment. If you smell exhaust fumes inside your vehicle, have your vehicle inspected immediately. Do not drive if you smell exhaust fumes.

## Important Ventilating Information

If you stop your vehicle and then leave the engine idling for long periods, we recommend that you do one of the following:

- Open the windows at least 3 cm (1 in).
- Set your climate control to outside air.

## Engine Warning Lamps



Malfunction Indicator Lamp  
Check Engine

If it illuminates when the engine is running this indicates a malfunction. The On Board Diagnostics system has detected a malfunction of the vehicle emission control system.

If it flashes, engine misfire may be occurring. Increased exhaust gas temperatures could damage the catalytic converter or other vehicle components. Avoid heavy acceleration and deceleration and have your vehicle immediately serviced.



Powertrain Warning Lamp

If it illuminates when the engine is running this indicates a malfunction. If it flashes when you are driving, immediately reduce the vehicle speed. Avoid heavy acceleration and deceleration and have your vehicle immediately serviced.

If both lamps illuminate when the engine is running, stop your vehicle as soon as it is safe to do so. Continuing to drive your vehicle may cause reduced power or the engine to stop. Switch the ignition off and attempt to restart the engine. Have your vehicle immediately checked.

# Starting and Stopping the Engine

## Starting System Information Messages

Message	Action
Full accessory power active	Displays if you switch the ignition on and do not start the engine.
Cranking time exceeded	Displays if you exceed the starting time limit. You cannot attempt to start the engine for 15 minutes. If you cannot start the engine after 15 minutes passes, have your vehicle immediately checked.
Starting system malfunction	Displays if you are unable to start your vehicle with a correctly coded key. The system has detected a fault that requires service. Have your vehicle checked as soon as possible.

## STARTING A DIESEL ENGINE - AUTOMATIC TRANSMISSION

Before starting your vehicle, check the following:

- Make sure the headlamps and electrical accessories are off.
- Make sure the parking brake is on.
- Make sure the transmission is in park (P).

### Vehicles with an Ignition Key

1. Turn the key to position **II**.
2. Wait until the glow plug indicator turns off.
3. Fully press the brake pedal.

**Note:** *Do not touch the accelerator pedal.*

4. Turn the key to position **III**.

**Note:** *Releasing the brake pedal when the engine is starting stops the engine cranking and the ignition returns to on.*

**Note:** *When the temperature is below -15°C (5°F), you may need to crank the engine for up to 10 seconds.*

**Note:** *You can only attempt to start the engine for a limited amount of time before the starting system temporarily disables. If you exceed the starting time limit, a message may appear and you cannot attempt to start the engine for at least 15 minutes.*

### Vehicles with a Push Button Ignition Switch

See **Push Button Ignition Switch** (page 123).

### Failure to Start

#### Vehicles with an Ignition Key

If the engine does not start, do the following:

1. Fully press the brake pedal.
2. Apply the parking brake.
3. Shift into park (P).
4. Turn the key to position **III** until the engine starts.

#### Vehicles with a Push Button Ignition Switch

See **Push Button Ignition Switch** (page 123).

# Starting and Stopping the Engine

## Stopping the Engine When Your Vehicle is Stationary

### Vehicles with an Ignition Key

1. Shift into park (P).
2. Turn the key to position **0**.
3. Apply the parking brake.

### Vehicles with a Push Button Ignition Switch

See **Push Button Ignition Switch** (page 123).

## Stopping the Engine When Your Vehicle is Moving



**WARNING:** Switching off the engine when your vehicle is still moving results in a significant decrease in braking assistance. Higher effort is required to apply the brakes and to stop your vehicle. A significant decrease in steering assistance could also occur. The steering does not lock, but higher effort could be required to steer your vehicle. When you switch the ignition off, some electrical circuits, for example airbags, also turn off. If you unintentionally switch the ignition off, shift into neutral (N) and restart the engine.

### Vehicles with an Ignition Key

1. Shift into neutral and use the brakes to bring your vehicle to a safe stop.
2. Shift into park (P).
3. Turn the key to position **0**.
4. Apply the parking brake.

### Vehicles with a Push Button Ignition Switch

See **Push Button Ignition Switch** (page 123).

## Guarding Against Exhaust Fumes



**WARNING:** Exhaust leaks may result in entry of harmful and potentially lethal fumes into the passenger compartment. If you smell exhaust fumes inside your vehicle, have your vehicle inspected immediately. Do not drive if you smell exhaust fumes.

## Important Ventilating Information

If you stop your vehicle and then leave the engine idling for long periods, we recommend that you do one of the following:

- Open the windows at least 3 cm (1 in).
- Set your climate control to outside air.

## Glow Plug Indicator



If it illuminates, wait until it turns off before starting.

## Engine Warning Lamps



Malfunction Indicator Lamp  
Check Engine

If it illuminates when the engine is running this indicates a malfunction. The On Board Diagnostics system has detected a malfunction of the vehicle emission control system.

If it flashes, engine misfire may be occurring. Increased exhaust gas temperatures could damage the diesel particulate filter or other vehicle components. Avoid heavy acceleration and deceleration and have your vehicle immediately serviced.



Powertrain Warning Lamp

# Starting and Stopping the Engine

If it illuminates when the engine is running this indicates a malfunction. If it flashes when you are driving, immediately reduce the vehicle speed. Avoid heavy acceleration and deceleration and have your vehicle immediately serviced.

If both lamps illuminate when the engine is running, stop your vehicle as soon as it is safe to do so. Continuing to drive your vehicle may cause reduced power or the engine to stop. Switch the ignition off and attempt to restart the engine. Have your vehicle immediately checked.

## Starting System Information Messages

Message	Action
Full accessory power active	Displays if you switch the ignition on and do not start the engine.
Cranking time exceeded	Displays if your vehicle fails to start.
Starting system malfunction	Displays if you are unable to start your vehicle with a correctly coded key. The system has detected a fault that requires service. Have your vehicle checked as soon as possible.

## STARTING A DIESEL ENGINE - MANUAL TRANSMISSION

Before starting your vehicle, check the following:

- Make sure the headlamps and electrical accessories are off.
- Make sure the parking brake is on.
- Make sure the transmission is in neutral.

### Vehicles with an Ignition Key

1. Turn the key to position **II**.
2. Wait until the glow plug indicator turns off.
3. Fully press the clutch pedal.

**Note:** Do not touch the accelerator pedal.

4. Turn the key to position **III**.

**Note:** Releasing the clutch pedal when the engine is starting stops the engine cranking and the ignition returns to on.

**Note:** When the temperature is below  $-15^{\circ}\text{C}$  ( $5^{\circ}\text{F}$ ), you may need to crank the engine for up to 10 seconds.

**Note:** You can only attempt to start the engine for a limited amount of time before the starting system temporarily disables. If you exceed the starting time limit, a message may appear and you cannot attempt to start the engine for at least 15 minutes.

### Vehicles with a Push Button Ignition Switch

See **Push Button Ignition Switch** (page 123).

### Failure to Start

#### Vehicles with an Ignition Key

If the engine does not start, do the following:

1. Fully press the brake pedal.
2. Apply the parking brake.
3. Shift into neutral.

# Starting and Stopping the Engine

4. Turn the key to position **III** until the engine starts.

## Vehicles with a Push Button Ignition Switch

See **Push Button Ignition Switch** (page 123).

## Stopping the Engine When Your Vehicle is Stationary

### Vehicles with an Ignition Key

1. Shift into neutral.
2. Turn the key to position **0**.
3. Apply the parking brake.

### Vehicles with a Push Button Ignition Switch

See **Push Button Ignition Switch** (page 123).

## Stopping the Engine When Your Vehicle is Moving



**WARNING:** Switching off the engine when your vehicle is still moving results in a significant decrease in braking assistance. Higher effort is required to apply the brakes and to stop your vehicle. A significant decrease in steering assistance could also occur. The steering does not lock, but higher effort could be required to steer your vehicle. When you switch the ignition off, some electrical circuits, for example airbags, also turn off. If you unintentionally switch the ignition off, shift into neutral (N) and restart the engine.

### Vehicles with an Ignition Key

1. Shift into neutral and use the brakes to bring your vehicle to a safe stop.
2. Turn the key to position **0**.

3. Apply the parking brake.

## Vehicles with a Push Button Ignition Switch

See **Push Button Ignition Switch** (page 123).

## Guarding Against Exhaust Fumes



**WARNING:** Exhaust leaks may result in entry of harmful and potentially lethal fumes into the passenger compartment. If you smell exhaust fumes inside your vehicle, have your vehicle inspected immediately. Do not drive if you smell exhaust fumes.

## Important Ventilating Information

If you stop your vehicle and then leave the engine idling for long periods, we recommend that you do one of the following:

- Open the windows at least 3 cm (1 in).
- Set your climate control to outside air.

## Glow Plug Indicator



If it illuminates, wait until it turns off before starting.

## Engine Warning Lamps



Malfunction Indicator Lamp  
Check Engine

If it illuminates when the engine is running this indicates a malfunction. The On Board Diagnostics system has detected a malfunction of the vehicle emission control system.

# Starting and Stopping the Engine

If it flashes, engine misfire may be occurring. Increased exhaust gas temperatures could damage the diesel particulate filter or other vehicle components. Avoid heavy acceleration and deceleration and have your vehicle immediately serviced.



Powertrain Warning Lamp

If it illuminates when the engine is running this indicates a malfunction. If it flashes when you are driving, immediately reduce the vehicle speed. Avoid heavy acceleration and deceleration and have your vehicle immediately serviced.

If both lamps illuminate when the engine is running, stop your vehicle as soon as it is safe to do so. Continuing to drive your vehicle may cause reduced power or the engine to stop. Switch the ignition off and attempt to restart the engine. Have your vehicle immediately checked.

## Starting System Information Messages

Message	Action
Full accessory power active	Displays if you switch the ignition on and do not start the engine.
Cranking time exceeded	Displays if your vehicle fails to start.
Starting system malfunction	Displays if you are unable to start your vehicle with a correctly coded key. The system has detected a fault that requires service. Have your vehicle checked as soon as possible.

## SWITCHING OFF THE ENGINE

### Vehicles With a Turbocharger



**WARNING:** Do not switch the engine off when it is running at high speed. If you do, the turbocharger will continue running after the engine oil pressure has dropped to zero. This will lead to premature turbocharger bearing wear.

Release the accelerator pedal. Wait until the engine has reached idle speed and then switch it off.

## ENGINE BLOCK HEATER



**WARNING:** Failure to follow engine block heater instructions could result in property damage or serious personal injury.



**WARNING:** Do not use your heater with ungrounded electrical systems or two-pronged adapters. There is a risk of electrical shock.

# Starting and Stopping the Engine

---

The heater warms the engine coolant. This allows the climate control system to quickly respond. The equipment includes a heater element installed in the engine block and a wire harness. You can connect the system to a grounded 220-240 volt AC electrical source.

**Note:** *The heater is most effective when the ambient temperature is below -18°C (0°F).*

We recommend that you do the following for a safe and correct operation:

- Use an extension cord suitable for outdoor use and in cold temperatures. It should be clearly marked that it is suitable for use with outdoor appliances. Do not use an indoor extension cord outdoors. This could result in an electric shock or become a fire hazard.
- Use as short an extension cord as possible.
- Do not use multiple extension cords.
- Make sure that when in operation, the extension cord plug and heater cord plug connections are free and clear of water. This could result in an electric shock or become a fire hazard.
- Make sure that you park your vehicle in a clean area, clear of combustible materials.
- Make sure that you firmly connect the heater, heater cord and extension cord.
- Check for heat anywhere in the electrical hookup when the system has been operating for approximately 30 minutes.

- Make sure that you unplug and properly stow the system before starting and driving your vehicle. Make sure the protective cover seals the terminals of the block heater cord plug when not in use.
- Make sure that you check the heater system for proper operation before winter.

## Using the Engine Block Heater

The engine block heater plug may be found in one of the following locations:

- Under the hood.
- In the front fog lamp bezel.
- Front lower grille.

Make sure the receptacle terminals are clean and dry before use. Clean them with a dry cloth if necessary.

The heater uses 0.4 to 1.0 kilowatt-hours of energy per hour of use. The system does not have a thermostat. It reaches maximum temperature after approximately three hours of operation. Using the heater longer than three hours does not improve system performance and unnecessarily uses electricity.

# Unique Driving Characteristics

## AUTO-START-STOP - AUTOMATIC TRANSMISSION



**WARNING:** Always switch the ignition off and fully apply the parking brake before carrying out any maintenance or leaving your vehicle. Failure to follow this instruction could result in personal injury or death if the engine restarts.

### Principle of Operation

The system is designed to help reduce fuel consumption and CO<sub>2</sub> emissions by stopping the engine when it is idling, for example at traffic lights. Your vehicle has an enhanced starter motor that is designed for an increased number of engine starts.

The system does not stop the engine under certain conditions, for example:

- If you have opened the driver door.
- If you have unfastened the driver seatbelt.
- If your vehicle is at high altitude.
- If you have switched the heated windshield on.
- If you have shifted into manual (M).
- If your vehicle is on a steep grade.
- If the engine is warming up.
- If the outside temperature is too low or too high.
- If the battery charge is low or the battery temperature is outside the optimal operating range.
- To maintain the interior climate or reduce fogging.
- If you have turned the steering more than 270 degrees.

The system restarts the engine under certain conditions, for example:

- If you have opened the driver door.
- If you have unfastened the driver seatbelt.
- If you switch the heated windshield on.
- If you switch maximum defrost on.
- If you turn the steering wheel.
- If your vehicle starts to roll downhill in neutral.
- To maintain adequate brake assistance.
- To maintain the interior climate or reduce fogging.

**Note:** *The blower motor speed could change when the system restarts the engine.*

### Using Auto-Start-Stop



**WARNING:** Apply the parking brake and shift into park (P) before leaving your vehicle.

### Stopping the Engine

Stop your vehicle and keep your foot on the brake pedal and the transmission in drive (D).

**Note:** *The engine stops if you shift into park (P) or neutral (N) regardless of whether you have your foot on the brake pedal or not.*

**Note:** *Power assist steering turns off when the engine is off.*

### Restarting the Engine

- Release the brake pedal.
- Press the accelerator pedal.
- Shift into drive (D), reverse (R) or manual (M).

# Unique Driving Characteristics

## Switching the System On and Off



The system turns on when you switch the ignition on. Press the switch to switch it off.

**Note:** *OFF* illuminates in the switch.

Press the switch again to switch the system back on.

The auto-start-stop indicator illuminates green when the engine stops. It flashes amber and a message appears when you need to take an action.



The auto-start stop indicator illuminates grey with a strike out when the system is not available.

**Note:** *The system turns off when it detects a malfunction. If it remains off, have your vehicle checked as soon as possible.*

## Information Messages

Message	Condition	Action
Auto Start/Stop Press Brake to Start Engine	The system needs to restart the engine but requires your confirmation.	Press the brake pedal to restart the engine.
Auto Start/Stop Shift to P, then Restart Engine	The system is not functioning.	Shift into park (P) and restart the engine yourself.

## Replacing the Battery

Replace the battery with one of exactly the same specification for the system to function correctly.

## AUTO-START-STOP-MANUAL TRANSMISSION



**WARNING:** Always switch the ignition off and fully apply the parking brake before carrying out any maintenance or leaving your vehicle. Failure to follow this instruction could result in personal injury or death if the engine restarts.

## Principle of Operation

The system is designed to help reduce fuel consumption and CO<sub>2</sub> emissions by stopping the engine when it is idling, for example at traffic lights. Your vehicle has an enhanced battery and starter motor that are designed for an increased number of engine starts.

The system does not stop the engine under certain conditions, for example:

- If you have opened the driver door.
- If you have unfastened the driver seatbelt.
- If your vehicle is at high altitude.
- If you have switched the heated windshield on.
- If you have selected certain drive modes, for example sport.
- If the engine is warming up.
- If the outside temperature is too low or too high.

# Unique Driving Characteristics

- If the battery charge is low or the battery temperature is outside the optimal operating range.
- To maintain the interior climate or reduce fogging.

The system restarts the engine under certain conditions, for example:

- If you switch the heated windshield on.
- If you switch maximum A/C or maximum defrost on.
- If you turn the steering wheel.
- If your vehicle starts to roll downhill in neutral.
- To maintain adequate brake assistance.
- To maintain the interior climate or reduce fogging.

**Note:** *The blower motor speed could change when the system restarts the engine.*

## Using Auto-Start-Stop

### Stopping the Engine

1. Stop your vehicle.
2. Shift into neutral.
3. Release the clutch pedal.

**Note:** *Power assist steering turns off when the engine is off.*

### Restarting the Engine

Fully press the clutch pedal.

**Note:** *To obtain maximum benefit from the system, shift into neutral and release the clutch pedal whenever you stop your vehicle for more than three seconds.*

**Note:** *The system provides stall recovery. To restart the engine after stalling, fully press the clutch pedal.*

## Switching the System On and Off



The system turns on when you switch the ignition on. Press the switch to switch it off.

**Note:** *OFF illuminates in the switch.*

Press the switch again to switch the system back on.

The auto-start-stop indicator illuminates green when the engine stops. It flashes amber and a message appears when you need to take an action.



The auto-start stop indicator illuminates grey with a strike out when the system is not available.

**Note:** *You can display the reason why the system is not available in the information display.*

**Note:** *The system turns off when it detects a malfunction. If it remains off, have your vehicle checked as soon as possible.*

## Auto-Start-Stop Warning

Sounds when you open the driver door and the system has stopped the engine.

# Unique Driving Characteristics

## Information Messages

Message	Condition	Action
Auto StartStop Press a pedal to start engine	The system needs to restart the engine but requires your confirmation.	Press the accelerator pedal, brake pedal or clutch pedal.
Auto StartStop Manual restart required	The system is not functioning.	Restart the engine.
Auto StartStop Select neutral to start engine	The system needs to restart the engine but cannot because the transmission is in gear.	Shift into neutral and restart the engine.

## Replacing the Battery

Replace the battery with one of exactly the same specification for the system to function correctly.

## EcoSelect Indicator



Illuminates when you switch EcoSelect on.

## ECOSELECT

### About EcoSelect

EcoSelect is a drive mode that is designed to help you reduce fuel consumption. It changes the way that some vehicle systems operate to make your vehicle more efficient.

When you drive with EcoSelect switched on, you could notice:

- Changes in engine behavior.
- Reduced acceleration performance.
- Reduced blower motor speed.

### Switching EcoSelect On and Off



Press the button.

**Note:** *It remains on until you switch it off.*

# Fuel and Refueling

## SAFETY PRECAUTIONS



**WARNING:** Do not overfill the fuel tank. The pressure in an overfilled tank may cause leakage and lead to fuel spray and fire.



**WARNING:** The fuel system may be under pressure. If you hear a hissing sound near the fuel filler inlet, do not refuel until the sound stops. Otherwise, fuel may spray out, which could cause serious personal injury.



**WARNING:** Fuels can cause serious injury or death if misused or mishandled.



**WARNING:** Fuel may contain benzene, which is a cancer-causing agent.



**WARNING:** When refueling always shut the engine off and never allow sparks or open flames near the fuel tank filler valve. Never smoke or use a cell phone while refueling. Fuel vapor is extremely hazardous under certain conditions. Avoid inhaling excess fumes.

- Avoid inhaling fuel vapors. Inhaling fuel vapor can lead to eye and respiratory tract irritation. In severe cases, excessive or prolonged breathing of fuel vapor can cause serious illness and permanent injury.
- Avoid getting fuel in your eyes. If you splash fuel in your eyes, immediately remove contact lenses (if worn), flush with water for 15 minutes and seek medical attention. Failure to seek proper medical attention could lead to permanent injury.
- Fuels can be harmful if absorbed through the skin. If you splash fuel on your skin, clothing or both, promptly remove contaminated clothing and thoroughly wash your skin with soap and water. Repeated or prolonged skin contact causes skin irritation.
- Be particularly careful if you are taking Antabuse or other forms of Disulfiram for the treatment of alcoholism. Breathing fuel vapors could cause an adverse reaction, serious personal injury or sickness. Immediately call a physician if you experience any adverse reactions.

## FUEL QUALITY - GASOLINE



**WARNING:** Do not mix diesel with gasoline, gasohol or alcohol. This could cause an explosion.



**WARNING:** Do not use leaded gasoline or gasoline with additives containing other metallic compounds, for example manganese-based. They could damage the emission system.

Follow these guidelines when refueling:

- Extinguish all smoking materials and any open flames before refueling your vehicle.
- Always switch the engine off before refueling.
- Automotive fuels can be harmful or fatal if swallowed. Fuel is highly toxic and if swallowed can cause death or permanent injury. If fuel is swallowed immediately call a physician, even if no symptoms are immediately apparent. The toxic effects of fuel may not be apparent for hours.

# Fuel and Refueling

Use minimum 95 octane unleaded gasoline that meets the specification defined by EN 228 or the equivalent national specification.

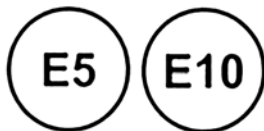

E268502

Your vehicle is suitable for use with ethanol blends up to 10% (E5 and E10).

**Note:** We recommend that you only use high quality fuel. We do not recommend the use of aftermarket fuel additives or other engine treatments.

## Long-Term Storage

Most gasoline contains ethanol. We recommend that you fill the fuel tank with fuel that does not contain ethanol if you intend to store your vehicle for more than two months.

## FUEL QUALITY - DIESEL

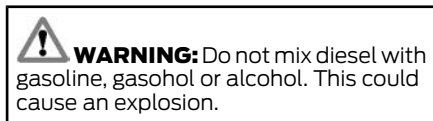

**WARNING:** Do not mix diesel with gasoline, gasohol or alcohol. This could cause an explosion.

Use diesel that meets the specification defined by EN 590 or the relevant national specification.



E268503

Your vehicle is suitable for use with biodiesel blends up to 7% (B7).

**Note:** We recommend that you only use high quality fuel. We do not recommend the use of aftermarket fuel additives or other engine treatments.

**Note:** We do not recommend the use of additional additives to prevent fuel waxing.

## Long-Term Storage

Most diesel fuels contain biodiesel. We recommend that you fill the fuel tank with fuel that does not contain biodiesel if you intend to store your vehicle for more than two months.

## FUEL FILLER FUNNEL LOCATION

The fuel filler funnel is in the glove compartment.

## RUNNING OUT OF FUEL

Running out of fuel can cause damage not covered by the vehicle Warranty.

# Fuel and Refueling

If your vehicle runs out of fuel:

- Add a minimum of 5 L (1.1 gal) of fuel to restart the engine.
- You may need to switch the ignition from off to on several times after refueling to allow the fuel system to pump the fuel from the tank to the engine. When restarting, cranking time takes a few seconds longer than normal.

**Note:** *If your vehicle is on a steep slope, more fuel may be required.*

## Filling a Portable Fuel Container



**WARNING:** Flow of fuel through a fuel pump nozzle can produce static electricity. This can cause a fire if you are filling an ungrounded fuel container.

Use the following guidelines to avoid electrostatic charge build-up, which can produce a spark, when filling an ungrounded fuel container:

- Only use an approved fuel container to transfer fuel to your vehicle. Place the container on the ground when filling it.
- Do not fill a fuel container when it is inside your vehicle (including the cargo area).
- Keep the fuel pump nozzle in contact with the fuel container when filling it.
- Do not use a device that holds the fuel pump nozzle lever in the fill position.

## Adding Fuel From a Portable Fuel Container



**WARNING:** Do not insert the nozzle of a fuel container or an aftermarket funnel into the fuel filler neck. This may damage the fuel system filler neck or its seal and cause fuel to run onto the ground.



**WARNING:** Do not try to pry open or push open the capless fuel system with foreign objects. This could damage the fuel system and its seal and cause injury to you or others.



**WARNING:** Do not dispose of fuel in the household refuse or the public sewage system. Use an authorized waste disposal facility.

When refueling the vehicle fuel tank from a fuel container, use the fuel filler funnel included with your vehicle. See **Fuel Filler Funnel Location** (page 143).

**Note:** *Do not use aftermarket funnels as they may not work with the capless fuel system and can damage it.*

When refueling the vehicle fuel tank from a fuel container, do the following:

1. Fully open the fuel filler door.
2. Fully insert the fuel filler funnel into the fuel filler inlet.

# Fuel and Refueling



E157452

3. Add fuel to your vehicle from the fuel container.
4. Remove the fuel filler funnel.
5. Fully close the fuel filler door.
6. Clean the fuel filler funnel and place it back in your vehicle or correctly dispose of it.

**Note:** *Extra funnels can be purchased from an authorized dealer if you choose to dispose of the funnel.*

## REFUELING

### Refueling System Overview

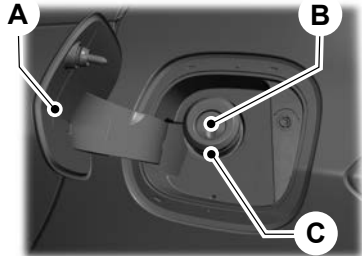

E267248

- A Fuel filler door.
- B Fuel tank filler valve.
- C Fuel tank filler pipe.

Your vehicle does not have a fuel tank filler cap.

# Fuel and Refueling

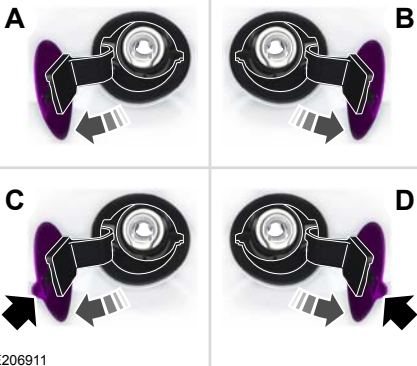

E206911

- A Left-hand side. To open the fuel filler door, press the center rear edge of the fuel filler door and then release.
- B Right-hand side. To open the fuel filler door, press the center rear edge of the fuel filler door and then release.
- C Left-hand side. Pull the rear of the fuel filler door to open it.
- D Right-hand side. Pull the rear of the fuel filler door to open it.

## Refueling Your Vehicle

**WARNING:** When refueling always shut the engine off and never allow sparks or open flames near the fuel tank filler valve. Never smoke or use a cell phone while refueling. Fuel vapor is extremely hazardous under certain conditions. Avoid inhaling excess fumes.

**WARNING:** The fuel system may be under pressure. If you hear a hissing sound near the fuel filler inlet, do not refuel until the sound stops. Otherwise, fuel may spray out, which could cause serious personal injury.

**WARNING:** Do not pry open the fuel tank filler valve. This could damage the fuel system. Failure to follow this instruction could result in fire, personal injury or death.

**WARNING:** Do not remove the fuel pump nozzle from its fully inserted position when refueling.

**WARNING:** Stop refueling when the fuel pump nozzle automatically shuts off for the first time. Failure to follow this will fill the expansion space in the fuel tank and could lead to fuel overflowing.

**WARNING:** Do not overfill the fuel tank. The pressure in an overfilled tank may cause leakage and lead to fuel spray and fire.

**WARNING:** Wait at least five seconds before removing the fuel pump nozzle to allow any residual fuel to drain into the fuel tank.

1. Fully open the fuel filler door.
2. Select the correct fuel pump nozzle for your vehicle.

# Fuel and Refueling

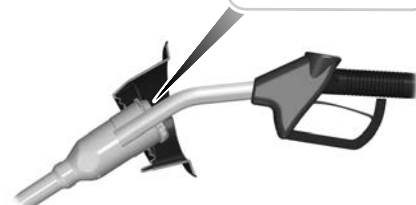
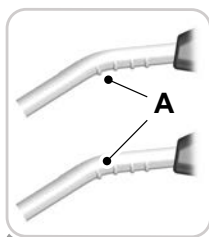

E139202

3. Insert the fuel pump nozzle up to the first notch on the nozzle A. Keep the fuel pump nozzle resting on the fuel tank filler pipe.

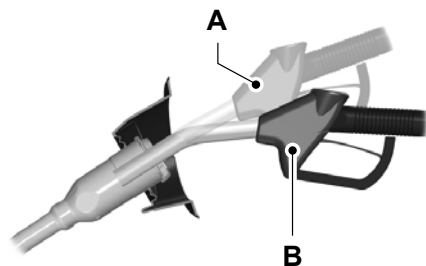

E139203

4. Hold the fuel pump nozzle in position B when refueling. Holding the fuel pump nozzle in position A can affect the flow of fuel and shut off the fuel pump nozzle before the fuel tank is full.

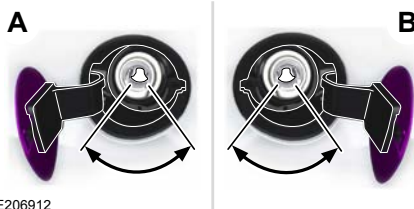

E206912

5. Operate the fuel pump nozzle within the area shown.

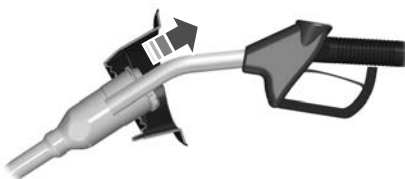

E119081

6. When you finish refueling slightly raise the fuel pump nozzle and slowly remove it.
7. Fully close the fuel filler door.

Do not attempt to start the engine if you have filled the fuel tank with incorrect fuel. Incorrect fuel use could cause damage not covered by the vehicle Warranty. Have your vehicle immediately checked.

## Refueling System Warning (If Equipped)

If the fuel tank filler valve does not fully close, a message could appear in the information display.

Message
Check fuel fill inlet

If the message appears, do the following:

1. Stop your vehicle as soon as it is safe to do so and switch the engine off.
2. Shift into park (P) or neutral (N).

# Fuel and Refueling

3. Apply the parking brake.
4. Fully open the fuel filler door.
5. Check the fuel tank filler valve for any debris that may be restricting its movement.
6. Remove any debris from the fuel tank filler valve.
7. Fully insert a fuel pump nozzle or the fuel filler funnel provided with your vehicle into the fuel filler pipe. See **Fuel Filler Funnel Location** (page 143). This action should dislodge any debris that may be preventing the fuel tank filler valve from fully closing.
8. Remove the fuel pump nozzle or fuel filler funnel from the fuel filler pipe.
9. Fully close the fuel filler door.

**Note:** *The message may not immediately reset. If the message continues to appear and a warning lamp illuminates, have your vehicle checked as soon as possible.*

## FUEL CONSUMPTION

We derive CO<sub>2</sub> and fuel consumption figures in laboratory tests according to Regulation (EC) 715/2007 or CR (EC) 692/2008 and subsequent amendments.

They are intended as a comparison between makes and models of vehicles. They are not intended to represent the real world fuel consumption you may get from your vehicle.

Real world fuel consumption is governed by many factors, for example driving style, high speed driving, stop-start driving, air conditioning usage, add-on accessories, payload and towing.

## Advertised Capacity

The advertised capacity is the maximum amount of fuel that you can add to the fuel tank when the fuel gauge indicates empty. See **Capacities and Specifications** (page 287).

In addition, the fuel tank contains an empty reserve. The empty reserve is an unspecified amount of fuel that remains in the fuel tank when the fuel gauge indicates empty.

**Note:** *The amount of fuel in the empty reserve varies and should not be relied upon to increase driving range.*

## Fuel Economy

Your vehicle calculates fuel economy figures through the trip computer average fuel function. See **Trip Computer** (page 82).

The first 1,500 km (1,000 mi) of driving is the break-in period of the engine. A more accurate measurement is obtained after 3,000 km (2,000 mi).

## Impacting Fuel Economy

- Incorrect tire inflation pressures. See **Tire Pressures** (page 276).
- Fully loading your vehicle.
- Carrying unnecessary weight.
- Adding certain accessories to your vehicle such as bug deflectors, rollbars or light bars, running boards and ski racks.
- Using fuel blended with alcohol. See **Fuel Quality** (page 143).
- Fuel economy may decrease with lower temperatures.
- Fuel economy may decrease when driving short distances.
- You may get better fuel economy when driving on flat terrain than when driving on hilly terrain.

# Engine Emission Control

## CATALYTIC CONVERTER - GASOLINE



**WARNING:** Do not park, idle or drive your vehicle on dry grass or other dry ground cover. The emission system heats up the engine compartment and exhaust system, creating the risk of fire.



**WARNING:** The normal operating temperature of the exhaust system is very high. Never work around or attempt to repair any part of the exhaust system until it has cooled. Use special care when working around the catalytic converter. The catalytic converter heats up to a very high temperature after only a short period of engine operation and stays hot after the engine is switched off.



**WARNING:** Exhaust leaks may result in entry of harmful and potentially lethal fumes into the passenger compartment. If you smell exhaust fumes inside your vehicle, have your vehicle inspected immediately. Do not drive if you smell exhaust fumes.

Your vehicle has various emission control components and a catalytic converter that enables it to comply with applicable exhaust emission standards.

To avoid damaging the catalytic converter:

- Do not crank the engine for more than 10 seconds at a time.
- Do not run the engine with a spark plug lead disconnected.
- Do not push-start or tow-start your vehicle. Use booster cables. See **Jump Starting the Vehicle** (page 228).
- Do not switch the ignition off when your vehicle is moving.

- Do not use leaded fuel.
- Avoid running out of fuel.

**Note:** *Resulting component damage may not be covered by the vehicle Warranty.*

## On-Board Diagnostics System

Your vehicle has an on-board diagnostics system that monitors the emission control system. If any of the following warning lamps illuminate, this may indicate that the on-board diagnostics system has detected an emission control system malfunction.



Continuing to drive your vehicle may cause reduced power or the engine to stop. Failure to respond to a warning lamp may cause component damage not covered by the vehicle Warranty. Have your vehicle checked as soon as possible.

See **Warning Lamps and Indicators** (page 76).

## SELECTIVE CATALYTIC REDUCTANT SYSTEM

Your vehicle has a selective catalytic reductant system to help reduce exhaust emission levels by injecting diesel exhaust fluid (AdBlue®) into the exhaust system. The engine may not start if you tamper with or disable the selective catalytic reductant system.

# Engine Emission Control

For the system to correctly operate, you must maintain the fluid level. The minimum fluid refill quantity required to restart the engine is 5 L (1.1 gal).

**Note:** *If your vehicle is on a gradient, the minimum fluid refill quantity required to restart the engine may be greater than 5 L (1.1 gal).*

## Diesel Exhaust Fluid (AdBlue) Guidelines

- Do not put in the vehicle fuel tank. This can cause engine damage not covered by the vehicle Warranty.
- Do not overfill the tank.
- Do not dilute with water or any other liquid.
- Do not re-use an empty fluid container.
- Do not store in direct sunlight.
- Store at temperatures between  $-5^{\circ}\text{C}$  ( $23^{\circ}\text{F}$ ) and  $20^{\circ}\text{C}$  ( $68^{\circ}\text{F}$ ).
- Do not store fluid containers in your vehicle.
- The fluid is non-flammable, non-toxic, colorless and water-soluble.

## Filling the Diesel Exhaust Fluid (AdBlue) Tank



E204215

The diesel exhaust fluid (AdBlue) tank filler pipe is next to the fuel tank filler pipe and has a blue cap. Fill the tank using a fluid pump at a diesel exhaust fluid (AdBlue) filling station or a diesel exhaust fluid (AdBlue) container.

**Note:** *Wash off any fluid that may have spilled on to a painted surface with soapy water.*

## Filling in Cold Climates

Diesel exhaust fluid may freeze when the temperature is below  $-11^{\circ}\text{C}$  ( $12^{\circ}\text{F}$ ). Your vehicle has a preheating system which allows the fluid to operate below  $-11^{\circ}\text{C}$  ( $12^{\circ}\text{F}$ ). If you overfill the diesel exhaust fluid (AdBlue) tank and the fluid freezes, it may cause damage not covered by the vehicle Warranty.

# Engine Emission Control

## Filling the Diesel Exhaust Fluid Tank Using a Fuel Station Pump



**WARNING:** Do not allow diesel exhaust fluid (AdBlue) to come into contact with eyes, skin or clothing. Should the fluid come into contact with eyes, flush them with plenty of water and seek medical attention. Clean affected skin with soap and water. If swallowed, drink plenty of water and seek medical attention immediately.



**WARNING:** Refill the diesel exhaust fluid (AdBlue) tank in a well-ventilated area. When removing the tank cap or a container cap, ammonia vapor may escape. Ammonia vapor is an irritant to the eyes, skin and mucous membranes. Inhaling ammonia vapor can cause burning to the eyes, throat and nose resulting in watering eyes or severe coughing.

Filling the diesel exhaust fluid (AdBlue) tank using a fuel station pump is similar to refueling your vehicle.

1. Fully open the fuel filler door.

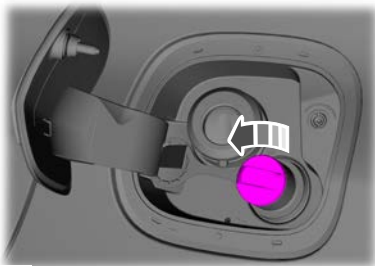

E268809

2. Remove the diesel exhaust fluid tank (AdBlue) filler cap.
3. Fully insert the diesel exhaust fluid (AdBlue) pump nozzle.

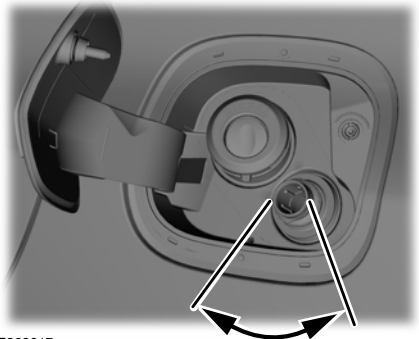

E268817

4. Operate the pump nozzle within the area shown.

**Note:** The pump nozzle shuts off when the tank is full.

5. Slightly raise the diesel exhaust fluid (AdBlue) pump nozzle and then slowly remove it.
6. Replace the diesel exhaust fluid tank filler cap. Turn it clockwise until you feel a strong resistance.

Do not attempt to start the engine if you have filled the diesel exhaust fluid (AdBlue) tank with incorrect fluid. Incorrect diesel exhaust fluid (AdBlue) use could cause damage not covered by the vehicle Warranty. Have your vehicle immediately checked.

# Engine Emission Control

## Filling the Diesel Exhaust Fluid (AdBlue) Tank Using a Container



**WARNING:** Do not allow diesel exhaust fluid (AdBlue) to come into contact with eyes, skin or clothing. Should the fluid come into contact with eyes, flush them with plenty of water and seek medical attention. Clean affected skin with soap and water. If swallowed, drink plenty of water and seek medical attention immediately.



**WARNING:** Refill the diesel exhaust fluid (AdBlue) tank in a well-ventilated area. When removing the tank cap or a container cap, ammonia vapor may escape. Ammonia vapor is an irritant to the eyes, skin and mucous membranes. Inhaling ammonia vapor can cause burning to the eyes, throat and nose resulting in watering eyes or severe coughing.

Always follow the manufacturer's instructions.

1. Remove the fluid container cap.
2. Place the spout on to the container and tighten it until you feel a strong resistance.

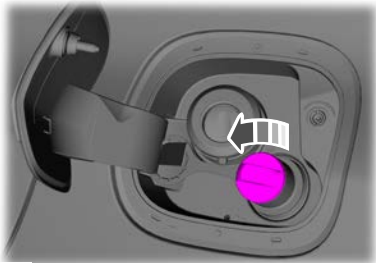

E268809

3. Remove the diesel exhaust fluid tank (AdBlue) filler cap.

4. Insert the spout into the diesel exhaust fluid (AdBlue) tank filler pipe until the seal on the spout fully seats.
5. Pour the fluid into the tank.

**Note:** *The fluid stops flowing when the tank is full.*

6. Return the container to the vertical position slightly below the diesel exhaust fluid (AdBlue) tank filler pipe.
7. Allow any fluid remaining in the spout to drain back into the container.
8. Remove the spout from the diesel exhaust fluid (AdBlue) tank filler pipe.
9. Remove the spout from the diesel exhaust fluid container and replace the cap.
10. Replace the diesel exhaust fluid tank filler cap. Turn it clockwise until you feel a strong resistance.

Do not attempt to start the engine if you have filled the diesel exhaust fluid (AdBlue) tank with incorrect fluid. Incorrect diesel exhaust fluid (AdBlue) use could cause damage not covered by the vehicle Warranty. Have your vehicle immediately checked.

## Selective Catalytic Reductant System Warning Lamp



The warning lamp illuminates if the system detects the diesel exhaust fluid (AdBlue) level is low or if there is a system malfunction.

If the warning lamp illuminates, the information display messages give you an indication whether the concern is fluid related or if there is a selective catalytic reductant system malfunction. If the warning lamp illuminates when your vehicle is moving, and the fluid is at a sufficient level, this indicates a system malfunction. Have your vehicle checked as soon as possible.

# Engine Emission Control

**Note:** When filling the diesel exhaust fluid tank from empty, there may be a short period before the increased diesel exhaust fluid level is registered.

## GASOLINE PARTICULATE FILTER



**WARNING:** Do not park or idle your vehicle over dry leaves, dry grass or other combustible materials. The regeneration process creates very high exhaust gas temperatures and the exhaust will radiate a considerable amount of heat during and after regeneration and after you have switched the engine off. This is a potential fire hazard.

To reduce the risk of causing damage to the gasoline particulate filter:

- Do not crank the engine for more than 10 seconds at a time.
- Do not push-start or tow-start your vehicle. Use booster cables.
- Do not switch the ignition off when your vehicle is moving.
- Do not ignore warning lamps, indicators or information messages.

### Gasoline Particulate Filter Regeneration

Particles in the exhaust gas collect in the gasoline particulate filter causing a gradual restriction over time. This restriction is removed through a regeneration process controlled by the engine control system. The regeneration process converts the particles in the exhaust gas into harmless gases.

Regeneration occurs during normal driving, to varying degrees depending on how you drive. Passive regeneration occurs when you drive at moderate to high speed but if you generally drive short distances at low speed, the engine control system could actively raise the exhaust gas temperature to remove the particles that have collected in the filter to make sure that it continues to correctly operate.

To assist passive regeneration, we recommend that you make occasional journeys that allow you to:

- Drive at a varied range of conditions, including highway conditions for a minimum of 20 minutes.
- Avoid prolonged engine idling.
- Select a suitable gear to maintain engine speed between 1500 and 4000 RPM.

If the filter is saturated or is approaching saturation, a warning lamp illuminates or a message appears in the information display.

**Note:** A warning lamp illuminates and a message appears in the information display on some vehicles.

If you do not take action when a warning lamp illuminates or a message appears in the information display, you could cause damage not covered by the vehicle Warranty.

### Gasoline Particulate Filter Warning Lamps and Indicators



Malfunction indicator lamp.

# Engine Emission Control

## Gasoline Particulate Filter Information Messages

Message	Action
Exhaust filter at limit Drive to clean	<ul style="list-style-type: none"><li>• Drive at a varied range of conditions, including highway conditions for 20 minutes or until the message disappears.</li><li>• Avoid prolonged engine idling.</li><li>• Select a suitable gear to maintain engine speed between 1500 and 4000 RPM.</li></ul>
Exhaust filter over limit Service now	<ul style="list-style-type: none"><li>• Drive at a moderate speed.</li><li>• Avoid heavy acceleration and deceleration.</li><li>• Have your vehicle checked as soon as possible.</li></ul>

## DIESEL PARTICULATE FILTER



**WARNING:** Do not park or idle your vehicle over dry leaves, dry grass or other combustible materials. The regeneration process creates very high exhaust gas temperatures and the exhaust will radiate a considerable amount of heat during and after regeneration and after you have switched the engine off. This is a potential fire hazard.



**WARNING:** The normal operating temperature of the exhaust system is very high. Never work around or attempt to repair any part of the exhaust system until it has cooled. Use special care when working around the diesel oxidation catalytic converter or the diesel particulate filter. The diesel oxidation catalytic converter and the diesel particulate filter heat up to very high temperatures after only a short period of engine operation and remain hot after you switch the engine off.

Your vehicle has various emission control components and a diesel particulate filter that enables it to comply with applicable exhaust emission standards. It filters harmful diesel particulates, for example soot from the exhaust gas.

To avoid damaging the diesel particulate filter:

- Do not crank the engine for more than 10 seconds at a time.
- Do not push-start or tow-start your vehicle. Use booster cables. See **Jump Starting the Vehicle** (page 228).
- Do not switch the ignition off when your vehicle is moving.
- Do not ignore warning lamps or information messages regarding exhaust system cleaning and regeneration.

**Note:** *This could result in damage not covered by the vehicle Warranty.*

# Engine Emission Control

## On-Board Diagnostics System

Your vehicle has an on-board diagnostics system that monitors the emission control system. If any of the following warning lamps illuminate, this indicates that the on-board diagnostics system has detected an emission control system malfunction.



Engine coolant temperature warning lamp.



Ignition warning lamp.



Malfunction indicator lamp.



Powertrain warning Lamp.



Water in fuel warning lamp.

If you continue to drive your vehicle when the warning lamp is illuminated, the engine could stop without warning. This could result in damage not covered by the vehicle Warranty. Have your vehicle checked as soon as possible.

See **Warning Lamps and Indicators** (page 76).

## Diesel Particulate Filter Automatic Regeneration



**WARNING:** Do not park or idle your vehicle over dry leaves, dry grass or other combustible materials. The regeneration process creates very high exhaust gas temperatures and the exhaust will radiate a considerable amount of heat during and after regeneration and after you have switched the engine off. This is a potential fire hazard.



**WARNING:** The normal operating temperature of the exhaust system is very high. Never work around or attempt to repair any part of the exhaust system until it has cooled. Use special care when working around the diesel oxidation catalytic converter or the diesel particulate filter. The diesel oxidation catalytic converter and the diesel particulate filter heat up to very high temperatures after only a short period of engine operation and remain hot after you switch the engine off.

The diesel particulate filter on your vehicle requires periodic regeneration to maintain correct operation. The emission control system automatically carries out this process. As soot gathers in the system it begins to restrict the filter. The soot that gathers inside the filter is cleaned in two different ways, passive regeneration and active regeneration. Both methods occur automatically and require no actions from the driver. During automatic regeneration, the system cleans the diesel particulate filter by oxidizing the soot. Cleaning happens during normal engine operating conditions at varying levels depending on driving conditions.



Diesel particulate filter warning lamp.

If the diesel particulate filter is near or at saturation, a warning lamp or information message appears in the information display. Drive your vehicle in a manner to allow effective diesel particulate filter cleaning.

The warning lamp continues to illuminate until the automatic regeneration process completes. Continue to drive your vehicle in a manner to allow effective diesel particulate filter cleaning until the warning lamp turns off.

# Engine Emission Control

Failure to carry out regeneration when required could result in a clogged diesel particulate filter. If the diesel particulate filter fills beyond the regeneration threshold, the system disables the ability to carry out regeneration. This could result in damage not covered by the vehicle Warranty.

Where vehicle use meets any of the following conditions:

- Driving short distances.
- Prolonged engine idling.
- Frequently switching the engine on and off.
- High levels of acceleration and deceleration.

We recommend you assist the regeneration process by:

- Avoiding prolonged engine idling.
- Drive your vehicle in a manner to allow effective cleaning. Drive at a steady vehicle speed of 48 km/h (30 mph) or above for approximately 20 minutes.



If the warning lamp illuminates the diesel particulate filter could have become overloaded. Have your vehicle checked as soon as possible.

Automatic regeneration raises the exhaust temperature to eliminate the soot particles. During cleaning soot particles are converted to harmless gasses. Once cleaned the diesel particulate filter continues to trap harmful diesel particles.

If you are driving your vehicle in a manner that allows effective cleaning, a message may appear in the information display to indicate automatic regeneration is in progress.

If you are not driving your vehicle in a manner that allows effective cleaning, a message may appear in the information display to instruct you to drive in a manner that allows automatic regeneration.

The automatic regeneration process is most effective when you drive at a steady vehicle speed of 48 km/h (30 mph) or above for approximately 20 minutes. The frequency and duration of the regeneration process varies by how you drive your vehicle, the outside air temperature and altitude. Frequency varies between 160 km (100 mi) and 500 km (310 mi) and each regeneration process lasts between 10 and 20 minutes.

**Note:** *Changes in the engine or exhaust sound may be heard during the regeneration process.*

**Note:** *During regeneration at low speed or engine idle, you could smell a hot metallic odor and could notice a clicking metallic sound. This is due to the high temperatures reached during the regeneration process. This is normal.*

## Diesel Particulate Filter Manual Regeneration (If Equipped)



**WARNING:** Do not park or idle your vehicle over dry leaves, dry grass or other combustible materials. The regeneration process creates very high exhaust gas temperatures and the exhaust will radiate a considerable amount of heat during and after regeneration and after you have switched the engine off. This is a potential fire hazard.



**WARNING:** The normal operating temperature of the exhaust system is very high. Never work around or attempt to repair any part of the exhaust system until it has cooled. Use special care when working around the diesel oxidation catalytic converter or the diesel

# Engine Emission Control

particulate filter. The diesel oxidation catalytic converter and the diesel particulate filter heat up to very high temperatures after only a short period of engine operation and remain hot after you switch the engine off.



Diesel particulate filter warning lamp.

If the diesel particulate filter is near or at saturation, the warning lamp appears advising you to initiate diesel particulate filter manual regeneration.

Before you start manual regeneration, do the following:

- Park your vehicle outside of any enclosed structure.
- Make sure the transmission is in park (P) or neutral (N).
- Make sure the parking brake is on.
- Park your vehicle a minimum of 3 m (10 ft) from any obstructions and materials that can easily combust or melt, for example, paper, leaves, fuels, plastics and other dry organic material.
- Make sure there is a minimum of 12 L (2.6 gal) of fuel in the fuel tank.
- Check the engine oil level.
- Check the engine coolant level.

## Manual Regeneration

Where vehicle use has significant engine idle operation, frequent vehicle speed less than 40 km/h (25 mph), or driving short distances where the engine does not fully warm up, manual regeneration allows you to start diesel particulate filter cleaning when the engine is idling.

Use the manual regeneration feature when:

- You are not able to drive in a manner that allows effective automatic cleaning. See **Diesel Particulate Filter Automatic Regeneration**.
- You choose to manually start the regeneration process when the engine is idling.

**Note:** *Changes in the engine or exhaust sound may be heard during the regeneration process.*

**Note:** *During regeneration at low speed or engine idle, you may smell a hot metallic odor and could notice a clicking metallic sound. This is due to the high temperatures reached during the regeneration process. This is normal.*

## Starting Manual Regeneration

You can only start manual regeneration with the engine running at normal operating temperature using the information display. See **Information Messages** (page 82).

**Note:** *During the use of manual regeneration, you may observe a light amount of white smoke. This is normal.*

**Note:** *If you press any pedal during manual regeneration the engine may turn off. To protect the exhaust system you may not be able to restart the engine for 10 minutes.*



If a warning illuminates you may not be able to start manual regeneration.

# Engine Emission Control

**To start manual regeneration, from the main menu scroll to:**

<b>Message</b>	<b>Action and Description</b>
Settings	Press the <b>OK</b> button or the right arrow button.
Exhaust filter full Clean soon	Press the <b>OK</b> button or the right arrow button.
<b>Select one of the following:</b>	
Exhaust filter at limit Clean now	Press the <b>OK</b> button or the right arrow button. Follow the prompts regarding exhaust position as required to start manual regeneration. Make sure you understand each prompt. The information display confirms that regeneration has started and when it is completed.
Exhaust filter overloaded Clean now	Press the <b>OK</b> button or the right arrow button. Follow the prompts regarding exhaust position as required to start manual regeneration. Make sure you understand each prompt. The information display confirms that regeneration has started and when it is completed.

**Note:** You cannot use the manual regeneration until the diesel particulate filter load percentage has reached 100 percent. The diesel particulate filter load percentage fluctuates when driving due to automatic regeneration.

When you start manual regeneration the engine speed rises to approximately 2000–2500 rpm and the cooling fan speed increases. A change in engine noise due to the cooling fan and engine speed increase may be heard during the regeneration process.

Depending on the amount of soot collected by the diesel particulate filter, the regeneration process varies depending on the outside air temperature and altitude. Manual regeneration may last up to 40 minutes.

When manual regeneration is complete the cooling fan and engine speed return to normal idling. The exhaust system remains very hot for several minutes after regeneration is complete. Do not reposition the vehicle over dry leaves, dry grass or other combustible materials until the exhaust system has had sufficient time to cool.

## **Interrupt or Cancel Manual Regeneration**

You can interrupt or cancel manual regeneration by switching the engine off. It may be possible to interrupt or cancel manual regeneration by pressing any pedal.

**Note:** To protect the exhaust system you may not be able to restart the engine for 10 minutes.

# Engine Emission Control

Depending on the amount of time allowed for manual regeneration to operate, soot may not have had sufficient time to be eliminated. The exhaust system may still be very hot for several minutes after regeneration.

If you switch the engine off during manual regeneration, turbo charger flutter occurs. This is a consequence of switching a diesel engine off during turbo charger boost operation, which is normal.

## Manual Regeneration with Automatic Regeneration Control

Where vehicle use has significant engine idle operation, frequent vehicle speed less than 40 km/h (25 mph), or driving short distances where the engine does not fully warm up, automatic regeneration could not sufficiently clean the diesel particulate filter. You can switch automatic regeneration off until you can drive your vehicle in a manner to allow effective cleaning, for example at a steady vehicle speed of 48 km/h (30 mph) or above for approximately 20 minutes. You can then switch automatic regeneration back on to clean the diesel particulate filter.

### To switch the automatic regeneration control on and off, from the main menu scroll to:

Message	Action and Description
Information	Press the <b>OK</b> button or the right arrow button.
Driver assist	Press the <b>OK</b> button or the right arrow button.
Auto exhaust cleaning off	Check the box to switch automatic regeneration off. Uncheck the box to switch automatic regeneration on.

# Transmission

## MANUAL TRANSMISSION

### General Information

Do not rest your hand on the gearshift lever or use the gearshift lever to hang and support objects. This could cause damage to the transmission not covered by the vehicle Warranty.

Do not rest your foot on the clutch pedal or use the clutch pedal to keep your vehicle stationary when waiting on a hill. This could cause damage to the clutch not covered by the vehicle Warranty.

Failure to fully press the clutch pedal could cause increased shift efforts, prematurely wear transmission components or damage to the transmission.

If any gear is not fully engaged, fully press the clutch pedal and shift into neutral. Release the clutch pedal for a moment, fully press the clutch pedal again and shift into gear.

### Shifting Into Reverse Gear

Do not shift into reverse gear when your vehicle is moving. This could cause damage to the transmission not covered by the vehicle Warranty.

1. Fully press the brake pedal.
2. Fully press the clutch pedal and shift into neutral.

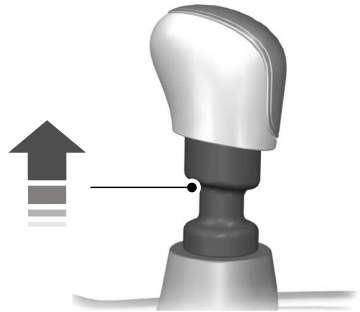

E99067

3. Raise the collar and shift into reverse gear.

## AUTOMATIC TRANSMISSION



**WARNING:** Do not apply the brake pedal and accelerator pedal simultaneously. Applying both pedals simultaneously for more than a few seconds will limit engine performance, which may result in difficulty maintaining speed in traffic and could lead to serious injury.

### Selector Lever Positions

The instrument cluster displays the current gear.

#### Park (P)

In park (P), power is not transmitted to the driven wheels and the transmission is locked. You can start the engine with the transmission in this position.

Shift into park (P) only when your vehicle is stationary.

# Transmission

## Reverse (R)

Shift into reverse (R) only when your vehicle is stationary and the engine is at idle speed.

## Neutral (N)

In neutral (N), power is not transmitted to the driven wheels but the transmission is not locked. You can start the engine with the transmission in this position.

## Drive (D)

Drive (D) is the normal position for driving.

## Manual (M)

In manual (M), you can upshift or downshift using the buttons on the selector lever.

## SelectShift™

### About SelectShift™

Use this feature to upshift or downshift using the buttons on the selector lever.

### Using SelectShift™

Shift into manual (M) to switch the feature on.

- Press the **+** button to upshift.
- Press the **-** button to downshift.

Shift into another gear to switch the feature off.

## Brake Shift Interlock

### About Brake Shift Interlock

Brake shift interlock prevents you from shifting out of park (P) when you have switched the ignition on and not pressed the brake pedal.

## Shifting Out of Park (P)



**WARNING:** Do not drive your vehicle until you verify that the stoplamps are working.



**WARNING:** If the parking brake is fully released, but the brake warning lamp remains illuminated, the brakes may not be working properly. Have your vehicle checked as soon as possible.

Use the brake shift interlock lever to move the selector lever out of park (P) if you cannot start the engine.

In the event of an electrical malfunction, it is possible that a fuse has blown or the stoplamps are not working. See **Fuse Specification Chart** (page 233).

If the vehicle battery has no charge, jump start your vehicle. See **Jump Starting the Vehicle** (page 228).



**WARNING:** When doing this procedure, you need to take the transmission out of park (P) which means your vehicle can roll freely. To avoid unwanted vehicle movement, always fully apply the parking brake prior to doing this procedure. Use wheels chocks if appropriate.

# Transmission

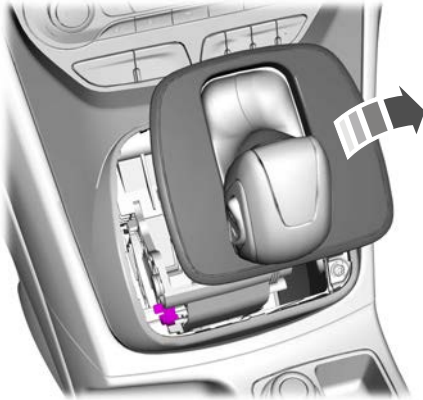

E275061

1. Using a flat-bladed screwdriver, remove the panel.



E142627

2. Locate the brake shift interlock lever.

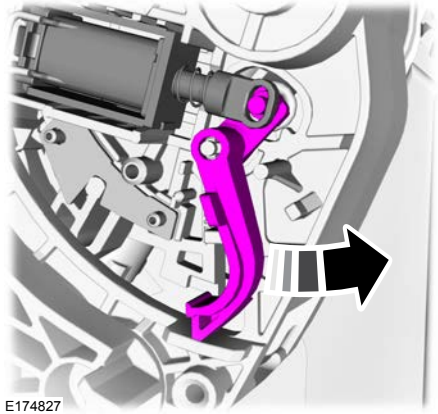

E174827

3. Push the brake shift interlock lever toward the rear of your vehicle and hold it there.
4. Move the selector lever from park (P) to neutral (N).
5. Install the panel.
6. Press the brake pedal, start the engine and release the parking brake.

**Note:** *Have your vehicle checked as soon as possible.*

# Brakes

## GENERAL INFORMATION

**Note:** Occasional brake noise is normal. If a metal-to-metal, continuous grinding or continuous squeal sound is present, the brake linings may be worn-out. If your vehicle has continuous vibration or shudder in the steering wheel while braking, have your vehicle checked by an authorized dealer.

**Note:** Brake dust may accumulate on the wheels, even under normal driving conditions. Some dust is inevitable as the brakes wear. See **Cleaning the Wheels** (page 259).

**Note:** Depending on applicable laws and regulations in the country for which your vehicle was originally built, the brake lamps may flash during heavy braking. Following this the hazard warning flashers may also flash when your vehicle comes to a stop.

Wet brakes result in reduced braking efficiency. Gently press the brake pedal a few times when driving from a car wash or standing water to dry the brakes.

## Brake Over Accelerator

In the event the accelerator pedal becomes stuck or entrapped, apply steady and firm pressure to the brake pedal to slow the vehicle and reduce engine power. If you experience this condition, apply the brakes and bring your vehicle to a safe stop. Shift the transmission to park (P) (automatic transmission) or to a low gear (manual transmission), switch the engine off and apply the parking brake. Inspect the accelerator pedal and the area around it for any items or debris that may be obstructing its movement. If none are found and the condition persists, have your vehicle towed to the dealer for service.

## Brake Assist

Brake assist detects when you brake heavily by measuring the rate at which you press the brake pedal. It provides maximum braking efficiency as long as you press the pedal. Brake assist can reduce stopping distances in critical situations.

## Anti-lock Brake System (If Equipped)

This system helps you maintain steering control and vehicle stability during emergency stops by keeping the brakes from locking.

## HINTS ON DRIVING WITH ANTI-LOCK BRAKES

The anti-lock braking system does not eliminate the risks when:

- You drive too closely to the vehicle in front of you.
- Your vehicle is hydroplaning.
- You take corners too fast.
- The road surface is poor.

**Note:** If the system activates, the brake pedal may pulse and may travel further. Maintain pressure on the brake pedal. You may also hear a noise from the system. This is normal.

## PARKING BRAKE - MANUAL TRANSMISSION



**WARNING:** Always set the parking brake fully.

**Note:** If you park your vehicle on a hill and facing uphill select first gear and turn the steering wheel away from the curb.

# Brakes

**Note:** If you park your vehicle on a hill and facing downhill select reverse gear and turn the steering wheel toward the curb.

**Note:** Do not press the release button while pulling the lever up.

To apply the parking brake:

1. Press the foot brake pedal firmly.
2. Pull the parking brake lever up to its fullest extent.

To release the parking brake:

1. Press the brake pedal firmly.
2. Pull the lever up slightly.
3. Press the release button and push the lever down.

## PARKING BRAKE - AUTOMATIC TRANSMISSION



**WARNING:** Always fully apply the parking brake and make sure you shift into park (P). Switch the ignition off and remove the key whenever you leave your vehicle.

To apply the parking brake:

1. Firmly press the brake pedal.
2. Pull the parking brake lever upward to its fullest extent.

**Note:** Do not press the release button when pulling the parking brake lever upward.

**Note:** If you park your vehicle on a hill and facing uphill, shift into park (P) and turn the steering wheel away from the curb.

**Note:** If you park your vehicle on a hill and facing downhill, shift into park (P) and turn the steering wheel toward the curb.

To release the parking brake:

1. Firmly press the brake pedal.

2. Slightly pull the parking brake lever upward.
3. Press the release button and push the parking brake lever downward.

## HILL START ASSIST



**WARNING:** The system does not replace the parking brake. When you leave your vehicle, always apply the parking brake. Failure to leave your vehicle securely parked may lead to a crash or injury. See **Parking Brake** (page 163).



**WARNING:** You must remain in your vehicle once the system activates. Failure to follow this warning could result in serious personal injury or death.



**WARNING:** During all times, you are responsible for controlling your vehicle, supervising the system and intervening, if required. Failure to take care may result in the loss of control of your vehicle, serious personal injury or death.



**WARNING:** The system will turn off if a malfunction is apparent or if you rev the engine excessively. Failure to take care may result in the loss of control of your vehicle, serious personal injury or death.

The system makes it easier to pull away when your vehicle is on a slope without the need to use the parking brake.

When the system is active, your vehicle will remain stationary on the slope for two to three seconds after you release the brake pedal. This allows time to move your foot from the brake to the accelerator pedal. The brakes are released automatically

# Brakes

---

once the engine has developed sufficient torque to prevent your vehicle from rolling down the slope. This is an advantage when pulling away on a slope, for example from a car park ramp, traffic lights or when reversing uphill into a parking space.

The system will turn on automatically on any slope which can result in significant vehicle rollback.

## Using Hill Start Assist

1. Press the brake pedal to bring your vehicle to a complete standstill. Keep the brake pedal pressed. If equipped with a manual transmission, also press the clutch pedal.
2. If the sensors detect that your vehicle is on a slope, the system will activate automatically.
3. When you remove your foot from the brake pedal, your vehicle will remain on the slope without rolling away for approximately two to three seconds. This hold time will automatically be extended if you are in the process of driving off.
4. Drive off in the normal manner. The brakes will be released automatically.

## Switching the System On and Off

### Vehicles with Manual Transmission

You can switch this feature on or off in the information display. The system remembers the last setting when you start your vehicle.

### Vehicles with Automatic Transmission

You cannot turn the system on or off. When you switch the ignition on, the system automatically turns on.

# Traction Control

## PRINCIPLE OF OPERATION

The traction control system helps avoid drive wheel spin and loss of traction.

If your vehicle begins to slide, the system applies the brakes to individual wheels and, when needed, reduces engine power at the same time. If the wheels spin when accelerating on slippery or loose surfaces, the system reduces engine power in order to increase traction.

## USING TRACTION CONTROL



**WARNING:** The stability and traction control light illuminates steadily if the system detects a failure. Make sure you did not manually disable the traction control system using the information display controls or the switch. If the stability control and traction control light is still illuminating steadily, have the system serviced by an authorized dealer immediately. Operating your vehicle with the traction control disabled could lead to an increased risk of loss of vehicle control, vehicle rollover, personal injury and death.

If your vehicle is stuck in mud or snow, switching traction control off may be beneficial as this allows the wheels to spin.

## Switching Traction Control On or Off



Press the button on the center console.

**Note:** The system turns on when you switch the ignition on.

**Note:** If you switch traction control off, stability control remains on.

**Note:** The system turns off if there is a malfunction.

## Traction Control Off Warning Lamp



Illuminates when you switch the system off.

## Traction Control Indicator



Flashes during operation.

If it does not illuminate when you switch the ignition on, or remains on when the engine is running, this indicates a malfunction. Have your vehicle checked as soon as possible.

# Stability Control

## PRINCIPLE OF OPERATION



**WARNING:** Vehicle modifications involving braking system, aftermarket roof racks, suspension, steering system, tire construction and wheel and tire size may change the handling characteristics of your vehicle and may adversely affect the performance of the electronic stability control system. In addition, installing any stereo loudspeakers may interfere with and adversely affect the electronic stability control system. Install any aftermarket stereo loudspeaker as far as possible from the front center console, the tunnel, and the front seats in order to minimize the risk of interfering with the electronic stability control sensors. Reducing the effectiveness of the electronic stability control system could lead to an increased risk of loss of vehicle control, vehicle rollover, personal injury and death.



**WARNING:** Remember that even advanced technology cannot defy the laws of physics. It's always possible to lose control of a vehicle due to inappropriate driver input for the conditions. Aggressive driving on any road condition can cause you to lose control of your vehicle increasing the risk of personal injury or property damage. Activation of the electronic stability control system is an indication that at least some of the tires have exceeded their ability to grip the road; this could reduce the operator's ability to control the vehicle potentially resulting in a loss of vehicle control, vehicle rollover, personal injury and death. If your electronic stability control system activates, SLOW DOWN.

The system automatically turns on each time you switch the ignition on.

If a fault occurs in either the stability control or the traction control system, you may experience the following conditions:

- The stability and traction control light illuminates steadily.
- The stability control and traction control systems do not enhance your vehicle's ability to maintain traction of the wheels.

If a driving condition activates either the stability control or the traction control system you may experience the following conditions:

- The stability and traction control light flashes.
- Your vehicle slows down.
- Reduced engine power.
- A vibration in the brake pedal.
- The brake pedal is stiffer than usual.
- If the driving condition is severe and your foot is not on the brake, the brake pedal may move as the system applies higher brake force.

The stability control system has several features built into it to help you maintain control of your vehicle:

### Electronic Stability Control

The system enhances your vehicle's ability to prevent skids or lateral slides by applying brakes to one or more of the wheels individually and, if necessary, reducing engine power.

### Roll Stability Control

The system enhances your vehicle's ability to prevent rollovers by detecting your vehicle's roll motion and the rate at which it changes by applying the brakes to one or more wheels individually.

# Stability Control

## Traction Control

The system enhances your vehicle's ability to maintain traction of the wheels by detecting and controlling wheel spin. See **Using Traction Control** (page 166).

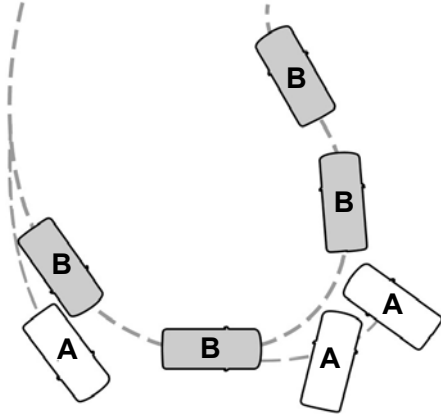

E72903

- A Vehicle without stability control skidding off its intended route.
- B Vehicle with stability control maintaining control on a slippery surface.

## USING STABILITY CONTROL

The system automatically turns on each time you switch the ignition on.

You cannot switch the stability control system off, but when you shift into reverse (R), the system deactivates.

You can switch the traction control system off or on. See **Using Traction Control** (page 166).

# Parking Aids (If Equipped)

## PRINCIPLE OF OPERATION



**WARNING:** The system may not detect objects with surfaces that absorb reflection. Always drive with due care and attention. Failure to take care may result in a crash.



**WARNING:** To help avoid personal injury, always use caution when in reverse (R) and when using the sensing system.



**WARNING:** The system may not detect small or moving objects, particularly those close to the ground.

**Note:** *Some accessories such as large trailer hitches, bike or surfboard racks can cause reduced performance or false alerts.*

**Note:** *Keep the sensors free from snow, ice and large accumulations of dirt. Blocked sensors may affect system accuracy. Do not clean the sensors with sharp objects.*

**Note:** *If your vehicle sustains damage leaving the sensors misaligned, this will cause inaccurate measurements or false alerts.*

**Note:** *The sensing system cannot be turned off when a MyKey is present. See **Principle of Operation** (page 37).*

We recommend that you take some time to get to know the system and its limitations by reading this section.

The sensing system warns the driver of obstacles within a certain range of your vehicle. The system automatically turns on each time you switch the ignition on.



You can turn the system on or off by pressing the parking aid button. If your vehicle does not have a parking aid button, the system can be switched off through the information display menu or from the pop-up message that appears once you shift the transmission into reverse (R). See **General Information** (page 80).

If a fault is present in the system, a warning message appears in the information display and does not allow you to switch the system on.

See **Information Messages** (page 82).

## REAR PARKING AID



**WARNING:** The system may not detect objects with surfaces that absorb reflection. Always drive with due care and attention. Failure to take care may result in a crash.



**WARNING:** The system may not detect small or moving objects, particularly those close to the ground.



**WARNING:** To help avoid personal injury, always use caution when in reverse (R) and when using the sensing system.



**WARNING:** The parking aid system can only assist you to detect objects when your vehicle is moving at parking speeds. To help avoid personal injury you must take care when using the parking aid system.

If the system malfunctions, a message appears in the information display.

**Note:** *Keep the sensors free from snow, ice and large accumulations of dirt.*

## Parking Aids (If Equipped)

**Note:** Do not cover up the sensors.

**Note:** Do not clean the sensors with sharp objects.

**Note:** If your vehicle sustains damage leaving the sensors misaligned, this may cause inaccurate measurements or false alerts.

**Note:** Some add-on accessories, for example large trailer hitches or bike or surfboard racks can cause reduced performance or false alerts.

The sensors are active when the transmission is in reverse (R) and the vehicle speed is less than 5 km/h (3 mph). When the parking aid system sounds a tone, the audio system may reduce the set volume.

A warning tone sounds when an object approaches your vehicle. As your vehicle moves closer to an object, the rate of the tone increases. The warning tone continuously sounds when an object is 30 cm (12 in) or less from the center of the rear bumper.

**Note:** There is a decreased coverage area at the outer corners.



E130178

Sensor coverage area is up to 180 cm (70 in) from the rear bumper.

The system detects large objects when you shift into reverse (R) and any of the following occur:

- Your vehicle is moving backward at low speed.
- Your vehicle is stationary but an object is approaching the rear of your vehicle at low speed.
- Your vehicle is moving backward at low speed and an object is moving toward your vehicle, for example another vehicle at low speed.

If your vehicle remains stationary for two seconds the audible warning turns off. If your vehicle moves backward the tone sounds again.

**Note:** If the detected object is 30 cm (12 in) or less from the rear bumper, the audible warning does not turn off.

### Object Distance Indicator (If Equipped)

When you shift into reverse (R), the system provides object distance indication through the information display.

- As the distance to the object decreases, the indicator blocks illuminate and move toward the vehicle icon.
- If there is no object detected, the distance indicator blocks are gray.

## Parking Aids (If Equipped)

### Rear Parking Aid Information Messages

Message	Description
Park Pilot malfunction	The system has malfunctioned. Have your vehicle checked as soon as possible.
Check Park Pilot	The system has malfunctioned. Have your vehicle checked as soon as possible.
Check rear Park Pilot	The system has malfunctioned. Have your vehicle checked as soon as possible.
Front Park Pilot not available Sensor blocked See manual	A sensor is blocked or the system has malfunctioned. Clean the bumper or remove any obstruction. If the message continues to appear, have your vehicle checked as soon as possible.
Rear Park Pilot not available Sensor blocked See manual	A sensor is blocked or the system has malfunctioned. Clean the bumper or remove any obstruction. If the message continues to appear, have your vehicle checked as soon as possible.

### FRONT PARKING AID

 **WARNING:** The system may not detect objects with surfaces that absorb reflection. Always drive with due care and attention. Failure to take care may result in a crash.

 **WARNING:** The system may not detect small or moving objects, particularly those close to the ground.

 **WARNING:** The parking aid system can only assist you to detect objects when your vehicle is moving at parking speeds. To help avoid personal injury you must take care when using the parking aid system.

The sensors are on the front bumper.

**Note:** *Keep the sensors free from snow, ice and large accumulations of dirt.*

**Note:** *Do not cover up the sensors.*

**Note:** *Do not clean the sensors with sharp objects.*

**Note:** *If your vehicle sustains damage leaving the sensors misaligned, this may cause inaccurate measurements or false alerts.*

The sensors are active when the transmission is in any position other than park (P). When the parking aid system sounds a tone, the audio system may reduce the set volume.

A warning tone sounds when an object approaches your vehicle. As your vehicle moves closer to an object, the rate of the tone increases. The warning tone continuously sounds when an object is 30 cm (12 in) or less from the front bumper.

The system turns off when the vehicle speed reaches 8 km/h (5 mph).

## Parking Aids (If Equipped)



E187330

Sensor coverage area is up to 70 cm (28 in) from the center of the bumper.

If the transmission is in reverse (R), the system detects objects when your vehicle is moving at low speed or an object is moving toward your vehicle, for example another vehicle at low speed. When you stop your vehicle, the audible warning turns off after two seconds.

If the transmission is in any forward gear, the system provides audible warnings when your vehicle is moving and an object is within the detection area. When you stop your vehicle, the audible warning turns off after two seconds and the visual warning turns off after four seconds.



Press the parking aid button to switch the system off.

If the system malfunctions, a message appears in the information display.

### Object Distance Indicator (If Equipped)

The system provides object distance indication through the information display.

- As the distance to the object decreases, the indicator blocks illuminate and move toward the vehicle icon.
- If there is no object detected, the distance indicator blocks are gray.

When you shift into reverse (R), the system provides audio warnings and visual indication when your vehicle is moving and the detected object is moving toward your vehicle. When you stop your vehicle, the audio warnings stop after two seconds. Visual indication remains on when the transmission is in reverse (R).

When you shift into any forward gear, the system provides audio warnings and visual indication when your vehicle is moving at a speed of approximately 8 km/h (5 mph) or below and the system detects an object within the detection zone. When you stop your vehicle, the audio warnings stop after two seconds and visual indication stops after four seconds.

**Note:** *If the detected object is 30 cm (12 in) or less from your vehicle, visual indication remains on.*

When you shift into neutral (N), the system only provides visual indication if your vehicle is moving at a speed of approximately 8 km/h (5 mph) or below, for example, your vehicle is moving on a slope, and the system detects an object moving toward your vehicle. When you stop your vehicle, visual indication stops after four seconds.

# Parking Aids (If Equipped)

## Front Parking Aid Information Messages

Message	Description
Park Pilot malfunction	The system has malfunctioned. Have your vehicle checked as soon as possible.
Check Park Pilot	The system has malfunctioned. Have your vehicle checked as soon as possible.
Check front Park Pilot	The system has malfunctioned. Have your vehicle checked as soon as possible.

## SIDE SENSING SYSTEM



**WARNING:** The system may not detect objects with surfaces that absorb reflection. Always drive with due care and attention. Failure to take care may result in a crash.



**WARNING:** The system may not detect small or moving objects, particularly those close to the ground.



**WARNING:** To help avoid personal injury, always use caution when in reverse (R) and when using the sensing system.



**WARNING:** The parking aid system can only assist you to detect objects when your vehicle is moving at parking speeds. To help avoid personal injury you must take care when using the parking aid system.

**Note:** Keep the sensors free from snow, ice and large accumulations of dirt.

**Note:** Do not cover up the sensors.

**Note:** Do not clean the sensors with sharp objects.

**Note:** If your vehicle sustains damage leaving the sensors misaligned, this may cause inaccurate measurements or false alerts.

**Note:** If you switch traction control off, the side sensing system also turns off.

**Note:** Some accessories, for example large trailer hitches or bike or surfboard racks can cause reduced performance or false alerts.

**Note:** The system does not detect an object that is moving toward the side of your vehicle, for example another vehicle moving at low speed, if it does not pass a front or rear sensor.

The system uses the front and rear outermost parking aid sensors to detect objects that are near to the sides of your vehicle. The system displays them on a virtual map in the information display as your vehicle moves past them.

The sensors are on the front and rear bumpers.

The system may not function if:

- You switch the ignition on, off and back on within a few seconds.
- Your vehicle remains stationary for over two minutes.
- The anti-lock brake system activates.
- The traction control system activates.

## Parking Aids (If Equipped)

To reinitialize the system, you may have to drive your vehicle approximately 3 m (10 ft).



E190458

The sensor coverage area is up to 60 cm (24 in) from the side of your vehicle.

When the system detects an object within the coverage area and the driving path of your vehicle, an audible warning sounds. As the object moves closer to your vehicle, the rate of the tone increases.

## Object Distance Indicator (If Equipped)



E190459

The system provides object distance indication through the information display.

- As the distance to the object decreases, the indicator blocks illuminate and move toward the vehicle icon.
- If there is no object detected, the distance indicator blocks are gray.

When you shift into reverse (R), the system provides audible warnings and visual indication when detected objects are within 60 cm (24 in) and are inside the driving path of your vehicle. When you stop your vehicle, the audible warnings turn off after two seconds.

## Parking Aids (If Equipped)

When you shift into any forward gear, the system provides audible warnings and visual indication when your vehicle is moving at a speed of approximately 8 km/h (5 mph) or below and the system detects an object within the detection zone. When you stop your vehicle, the audible warnings turn off after two seconds and visual indication turns off after four seconds.

When you shift into neutral (N), the system only provides visual indication if your vehicle is moving at a speed of approximately 8 km/h (5 mph) or below. For example, your vehicle is moving on a slope, and the system detects an object moving toward your vehicle. When you stop your vehicle, visual indication turns off after four seconds.

If the system is not available, the side distance indicator blocks do not display.

### ACTIVE PARK ASSIST



**WARNING:** You must remain in your vehicle when the system turns on. At all times, you are responsible for controlling your vehicle, supervising the system and intervening, if required. Failure to take care may result in the loss of control of your vehicle, serious personal injury or death.



**WARNING:** The sensors may not detect objects in heavy rain or other conditions that cause interference.



**WARNING:** You are responsible for controlling your vehicle at all times. The system is designed to be an aid and does not relieve you of your responsibility to drive with due care and attention. Failure to follow this instruction could result in the loss of control of your vehicle, personal injury or death.

Active park assist is a multi-step process and may require you to shift the transmission multiple times. Follow the onscreen instructions until the parking maneuver is complete.

If you are uncomfortable with the proximity to any vehicle or object, you may choose to override the system by grabbing the steering wheel, or by taking full control of your vehicle after pressing the active park assist button.

Keep your hands, hair, clothing and any loose items clear of the steering wheel when using active park assist.

The sensors are on the front and rear bumpers.

**Note:** *Keep the sensors free from snow, ice and large accumulations of dirt.*

**Note:** *Do not cover up the sensors.*

**Note:** *Do not clean the sensors with sharp objects.*

**Note:** *The sensors may not detect objects with surfaces that absorb ultrasonic waves. The sensors may falsely detect objects due to ultrasonic interference caused by, for example motorcycle exhausts, truck air brakes or horns.*

**Note:** *If you change any tires, the system must recalibrate and may not correctly operate for a short time.*

# Parking Aids (If Equipped)

The system may not correctly operate in any of the following conditions:

- You use a spare tire or a tire that is significantly worn more than the other tires.
- One or more tires are incorrectly inflated.
- You try to park on a tight curve.
- Something passes between the front bumper and the parking space. For example, a pedestrian or cyclist.
- The edge of the neighboring parked vehicle is high off the ground. For example, a bus, tow truck or flatbed truck.
- The weather conditions are poor. For example, during heavy rain, snow, fog, high humidity and high temperatures.

Do not use the system if:

- You have attached an add-on accessory close to the sensors on the front or rear of your vehicle. For example, a bike rack or trailer.
- You have attached an overhanging object to the roof. For example, a surfboard.
- The front bumper, rear bumper or the side sensors are damaged.
- The correct tire size is not in use on your vehicle. For example, a mini-spare tire.

## Using Active Park Assist

### Selecting an Active Park Assist Mode



Press the button once to activate parallel parking. Press the button a second time to activate perpendicular parking. If you press the button again the system switches off.

If your vehicle is parked and after you switch the ignition on, you can use the information display to toggle through the modes. Press the button to switch the system on and open the system menu in the information display.

**Note:** *If your vehicle is parked, the default mode is parallel park out assist. However if you did not use active park assist to parallel park your vehicle, use the information display to select park out assist.*

**Note:** *You can only repeatedly press the active park assist button to toggle through the modes after moving your vehicle approximately 3 m (10 ft).*

To toggle through the modes, use the buttons on the information display to select the following:

- Parallel parking.
- Perpendicular parking.
- Parallel park out assist.
- Switch the system off.

**Note:** *There is no time limit for toggling through the modes.*

### Parallel Parking

The system detects available parallel parking spaces and steers your vehicle into the space. You control the accelerator, gearshift and brakes. The system visually and audibly guides you into a parallel parking space.



Press the button once to search for a parking space.

**Note:** *You can also switch the system on after you have already driven partially or completely past a parking space. Press the active park assist button and the system informs you if you have recently passed a suitable parking space.*

## Parking Aids (If Equipped)

When the vehicle speed is less than 35 km/h (22 mph), the system scans both sides of your vehicle for an available parking space. A message and a graphic appear in the information display to indicate the system is searching for a parking space. Use the direction indicator to be offered parking spaces on either the left-hand side or right-hand side of your vehicle.

**Note:** The system scans both sides of your vehicle and offers parking spaces one side at a time if you do not use the direction indicator.

**Note:** The system defaults to the passenger side if you do not use the direction indicator.



Drive your vehicle approximately 1 m (3 ft) and parallel to the other parked vehicles when searching for a parking space.

**Note:** If you drive your vehicle less than 0.5 m (2 ft) or greater than 1.5 m (5 ft) away from other parked vehicles, the system may not be able to detect an available parking space.

When the system detects a suitable space, a message displays and a tone sounds. Stop your vehicle and follow the onscreen instructions. If your vehicle is moving very slowly, you may have to move forward a short distance before the system is ready to park.

**Note:** You must observe that the space the system selects remains clear of obstructions at all times during the maneuver.

**Note:** The system always offers the last parking space it detects. For example, if your vehicle detects multiple spaces when you are driving, it offers the last one.

**Note:** If the vehicle speed is greater than approximately 35 km/h (22 mph), the system shows a message to instruct you to reduce the vehicle speed.

### Automatically Steering into a Parallel Parking Space

When you shift into reverse (R), with your hands off the steering wheel and nothing obstructing its movement, your vehicle steers itself into the space. The system displays instructions to move your vehicle backward and forward in the space.

**Note:** If the vehicle speed exceeds approximately 9 km/h (6 mph), you interrupt the maneuver, or the system switches off, you must take full control of your vehicle.

**Note:** If the system detects an object is very close to your vehicle and it may be unsafe to continue the maneuver, it may instruct you to stop your vehicle. The system may not provide any further instruction. Steering assistance continues to operate but you must decide if it is safe to continue the maneuver.



When you believe your vehicle is correctly parked, or a solid tone sounds and an information message appears, bring your vehicle to a complete stop.

When the Active Park Assist maneuver is complete, a tone sounds and an information message appears.

**Note:** You are responsible for checking how your vehicle is parked and making any necessary corrections before leaving your vehicle.

# Parking Aids (If Equipped)

## Brake System Intervention

The detection of objects and activation of the brake intervention system depends on certain conditions. For example vehicle load, adverse weather conditions or other conditions that may affect the system sensors.

When active park assist is controlling the steering, it may under certain conditions apply the brakes to slow or stop your vehicle.

- The brakes may be applied at a vehicle speed of approximately 8 km/h (5 mph). This feature attempts to keep the vehicle speed within the limits for assisted parking. Brake system intervention to slow your vehicle does not cancel the active park assist maneuver.
- The brakes may be applied if an obstacle is detected within the intended vehicle path. Brake system intervention may bring the vehicle to a complete stop and may decrease the effects of a crash. If the vehicle comes to a complete stop, the brakes can remain applied for a short period of time. If this feature activates, it cancels the active park assist maneuver and you must take full control of your vehicle to complete the parking maneuver.

## Deactivating Active Park Assist

You can manually deactivate the system by:

- Pressing the Active Park Assist button during an active maneuver.
- Grabbing the steering wheel during an active maneuver.
- Driving above 35 km/h (22 mph) for 30 seconds when searching for a parking space.
- Driving above 50 km/h (31 mph).

- Driving above 9 km/h (6 mph) during an active maneuver.
- Switching the traction control system off.

Certain vehicle conditions may also deactivate the system, for example:

- The traction control system activates or fails.
- The anti-lock brake system activates or fails.

If the system malfunctions, a message appears and a tone sounds. Have your vehicle checked as soon as possible.

## Perpendicular Parking

The system detects available perpendicular parking spaces and steers your vehicle into the space. You control the accelerator, gearshift and brakes. The system visually and audibly guides you into a perpendicular parking space.



Press the button twice to search for a parking space.

When the vehicle speed is less than 30 km/h (19 mph), the system scans both sides of your vehicle for an available parking space. A message and a graphic appear in the information display to indicate the system is searching for a parking space. Use the direction indicator to be offered parking spaces on either the left-hand side or right-hand side of your vehicle.

**Note:** *The system scans both sides of your vehicle and offers parking spaces one side at a time if you do not use the direction indicator.*

**Note:** *The system defaults to the passenger side if you do not use the direction indicator.*

## Parking Aids (If Equipped)



Drive your vehicle approximately 1 m (3 ft) and parallel to the other parked vehicles when searching for a parking space.

**Note:** If you drive your vehicle less than 0.5 m (2 ft) or greater than 1.5 m (5 ft) away from other parked vehicles, the system may not be able to detect an available parking space.

When the system detects a suitable space, a message displays and a tone sounds. Stop your vehicle and follow the onscreen instructions. If your vehicle is moving very slowly, you may have to move forward a short distance before the system is ready to park.

**Note:** You must observe that the space the system selects remains clear of obstructions at all times during the maneuver.

**Note:** The system always offers the last detected parking space. For example, if your vehicle detects multiple spaces when you are driving, it offers the last one.

**Note:** If the vehicle speed is greater than approximately 30 km/h (19 mph), the system shows a message to instruct you to reduce the vehicle speed.

### Automatically Steering into a Perpendicular Parking Space

When you shift into reverse (R), with your hands off the steering wheel and nothing obstructing its movement, your vehicle steers itself into the space. The system displays instructions to move your vehicle backward and forward in the space.

**Note:** If the vehicle speed exceeds approximately 9 km/h (6 mph), you interrupt the maneuver, or the system switches off, you must take full control of your vehicle.

**Note:** If the system detects an object is very close to your vehicle and it may be unsafe to continue the maneuver, it may instruct you to stop your vehicle. The system may not provide any further instruction. Steering assistance continues to operate but you must decide if it is safe to continue the maneuver.

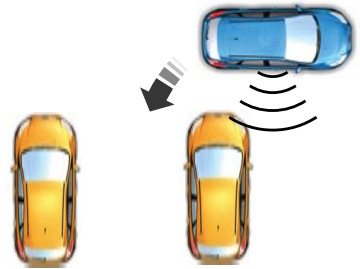

E186191

When you believe your vehicle is correctly parked, or a solid tone sounds and an information message appears, bring your vehicle to a complete stop.

When the active park assist maneuver is complete, a tone sounds and a message appears.

**Note:** You are responsible for checking how your vehicle is parked and making any necessary corrections before leaving your vehicle.

### Brake System Intervention

The detection of objects and activation of the brake intervention system depends on certain conditions. For example vehicle load, adverse weather conditions or other conditions that may affect the system sensors.

## Parking Aids (If Equipped)

When active park assist is controlling the steering, it may under certain conditions apply the brakes to slow or stop your vehicle.

- The brakes may be applied at a vehicle speed of approximately 8 km/h (5 mph). This feature attempts to keep the vehicle speed within the limits for assisted parking. Brake system intervention to slow your vehicle does not cancel the active park assist maneuver.
- The brakes may be applied if an obstacle is detected within the intended vehicle path. Brake system intervention may bring the vehicle to a complete stop and may decrease the effects of a crash. If the vehicle comes to a complete stop, the brakes can remain applied for a short period of time. If this feature activates, it cancels the active park assist maneuver and you must take full control of your vehicle to complete the parking maneuver.

### **Deactivating Active Park Assist**

You can manually deactivate the system by:

- Pressing the Active Park Assist button during an active maneuver.
- Grabbing the steering wheel during an active maneuver.
- Driving above 30 km/h (19 mph) for 30 seconds when searching for a parking space.
- Driving above 50 km/h (31 mph).
- Driving above 9 km/h (6 mph) during an active maneuver.
- Switching the traction control system off.

Certain vehicle conditions may also deactivate the system, for example:

- The traction control system activates or fails.
- The anti-lock brake system activates or fails.

If the system malfunctions, a message appears and a tone sounds. Have your vehicle checked as soon as possible.

### **Parallel Park Out Assist**

The system steers your vehicle out of a parallel parking space. You control the accelerator, gearshift and brakes. The system visually and audibly guides you out of a parallel parking space.

**Note:** *This system is not intended to assist when exiting a perpendicular parking space.*



Press the button once when your vehicle is stationary in a parallel parking space.

**Note:** *If you did not use active park assist to parallel park your vehicle, pressing the button once selects parallel park. You must use the information display to select park out assist.*

The system displays a message instructing you to switch a direction indicator on. Use the direction indicator to select which side of your vehicle you want to exit the parking space. The system displays instructions to move your vehicle backward and forward in the space.

**Note:** *If the system detects an object is very close to your vehicle and it may be unsafe to continue the maneuver, it may instruct you to stop your vehicle. The system may not provide any further instruction. Steering assistance continues to operate but you must decide if it is safe to continue the maneuver.*

## Parking Aids (If Equipped)



After the system directs your vehicle to a position where you can exit the parking space in a forward movement, a message appears instructing you to take full control of your vehicle. Generally hand-over is when your vehicle is still inside the parking space.

**Note:** *Parallel Park Out Assist may not be available when the clearance to the front or the rear of your vehicle is too small.*

**Note:** *If the vehicle speed exceeds approximately 9 km/h (6 mph), you interrupt the maneuver, or the system switches off, you must take full control of your vehicle.*

**Note:** *You are responsible for controlling your vehicle and making sure the path is clear prior to pulling into traffic.*

### Brake System Intervention

The detection of objects and activation of the brake intervention system depends on certain conditions. For example vehicle load, adverse weather conditions or other conditions that may affect the system sensors.

When active park assist is controlling the steering, it may under certain conditions apply the brakes to slow or stop your vehicle.

- The brakes may be applied if an obstacle is detected within the intended vehicle path. Brake system intervention may bring the vehicle to a complete stop and may decrease the effects of a crash. If the vehicle comes to a complete stop, the brakes can remain applied for a short period of time. If this feature activates, it cancels the active park assist maneuver and you must take full control of your vehicle to complete the parking maneuver.

### Troubleshooting

Symptom	Possible Cause
The system does not search for a parking space.	You may have switched the traction control off.
	The transmission is in reverse (R). Your vehicle must be moving forward to be able to detect a parking space.
The system does not offer a parking space.	The sensors may be blocked. For example, snow, ice or dirt buildup. Blocked sensors can affect how the system functions.
	There is not enough room in the parking space for your vehicle to safely park.
	There is not enough space for the parking maneuver on the opposite side of the parking space.
	The parking space is more than 1.5 m (5 ft) or less than 0.5 m (2 ft) away.

## Parking Aids (If Equipped)

Symptom	Possible Cause
	The vehicle speed is greater than 35 km/h (22 mph) for parallel parking or greater than 30 km/h (19 mph) for perpendicular parking.
	You recently disconnected or replaced the battery. After you reconnect the battery you must drive your vehicle on a straight road for a short period of time.
The system does not correctly position your vehicle in a parking space.	Your vehicle is rolling in the opposite direction of the current transmission position. For example, rolling forward when in reverse (R).
	An irregular curb along the parking space prevents the system from correctly aligning your vehicle.
	Vehicles or objects bordering the space may not be correctly parked.
	Your vehicle stopped too far past the parking space.
	The tires may not be correctly installed or maintained. For example, not inflated correctly, improper size, or of different sizes.
	A repair or alteration changes the detection capabilities.
	A parked vehicle has a high attachment. For example, a salt sprayer, snowplow or moving truck bed.
	The parking space length or position of parked objects changes after your vehicle passes the space.
	The temperature around your vehicle quickly changes. For example, driving from a heated garage into the cold, or after leaving a car wash.

### REAR VIEW CAMERA



**WARNING:** The rear view camera system is a reverse aid supplement device that still requires the driver to use it in conjunction with the interior and exterior mirrors for maximum coverage.



**WARNING:** The camera may not detect objects that are very close to your vehicle.



**WARNING:** Reverse your vehicle slowly. Failure to follow this instruction could result in the loss of control of your vehicle, personal injury or death.

## Parking Aids (If Equipped)



**WARNING:** Use caution when the rear cargo door is ajar. If the rear cargo door is ajar, the camera will be out of position and the video image may be incorrect. All guidelines disappear when the rear cargo door is ajar. Failure to follow this instruction could result in personal injury.



E165579



E165580

### Switching the Rear View Camera On

Switch the ignition and the audio unit on.  
Shift into reverse (R).

The image displays in the information display or the interior mirror.

The system may not correctly operate in any of the following conditions:

- Dark areas.
- Intense light areas.
- If there is a sudden change to the outside temperature.
- If the camera is wet.
- If the camera is obstructed.

### Using the Display



**WARNING:** Objects in the display are closer than they appear.



**WARNING:** Objects above the camera may not be visible. Check the area behind your vehicle when necessary.

Distance markers are only a guide and are calculated for unloaded vehicles on an even road surface.

The lines show a projected vehicle path and the approximate distance from the rear bumper to an object.

## Parking Aids (If Equipped)

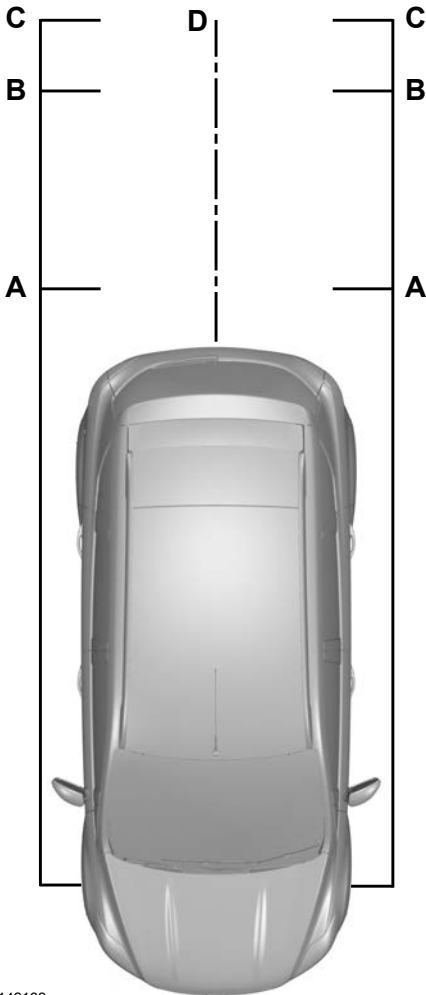

C Green zone.

D Center line of the projected vehicle path.

**Note:** When reversing with a trailer the camera shows the direction of your vehicle and not the direction of the trailer.

**Note:** When reversing with a trailer the screen does not display the lines.

### Switching the Rear View Camera Off

The image turns off when you shift out of reverse (R).

### Rear View Camera Delay

You cannot switch the rear view camera delay off.

**Note:** The system automatically turns off when your vehicle speed has reached approximately 12 km/h (7.5 mph).

**Note:** The interior mirror does not have the rear view camera delay feature.

### Vehicles With Parking Aid (If Equipped)

The display shows colored distance bars.

E142132

A Red zone.

B Amber zone.

# Cruise Control

## PRINCIPLE OF OPERATION

Cruise control lets you maintain a set speed without keeping your foot on the accelerator pedal. You can use cruise control when your vehicle speed is greater than 30 km/h (20 mph).

## USING CRUISE CONTROL



**WARNING:** Do not use cruise control on winding roads, in heavy traffic or when the road surface is slippery. This could result in loss of vehicle control, serious injury or death.



**WARNING:** When you are going downhill, your vehicle speed could increase above the set speed. The system does not apply the brakes.



E142437

The cruise controls are on the steering wheel.

**Note:** Cruise control disengages if your vehicle speed decreases more than 16 km/h (10 mph) below the set speed when driving uphill.

## Switching Cruise Control On

Press and release **ON**.



The indicator appears in the information display.

## Setting the Cruise Speed

1. Drive to desired speed.
2. Press and release **SET+**.
3. Take your foot off the accelerator pedal.

## Changing the Set Speed

- Press and release **SET+** or **SET-**. When you select km/h as the display measurement in the information display the set speed changes in approximately 2 km/h increments. When you select mph as the display measurement in the information display the set speed changes in approximately 1 mph increments.
- Press the accelerator or brake pedal until you reach the desired speed. Press and release **SET+**.
- Press and hold **SET+** or **SET-**. Release the control when you reach the desired speed.

## Canceling the Set Speed

Pull and release **CAN** or tap the brake pedal. The set speed does not erase.

## Resuming the Set Speed

Pull and release **RES**.

## Switching Cruise Control Off

Press and release **OFF** when the system is in standby mode or switch the ignition off.

**Note:** You erase the set speed when you switch the system off.

# Cruise Control

## USING ADAPTIVE CRUISE CONTROL

 **WARNING:** Always pay close attention to changing road conditions when using adaptive cruise control. The system does not replace attentive driving. Failing to pay attention to the road may result in a crash, serious injury or death.

 **WARNING:** You are responsible for controlling your vehicle at all times. The system is designed to be an aid and does not relieve you of your responsibility to drive with due care and attention. Failure to follow this instruction could result in the loss of control of your vehicle, personal injury or death.

 **WARNING:** Adaptive cruise control may not detect stationary or slow moving vehicles below 10 km/h (6 mph).

 **WARNING:** Do not use adaptive cruise control on winding roads, in heavy traffic or when the road surface is slippery. This could result in loss of vehicle control, serious injury or death.

 **WARNING:** Do not use the system when towing a trailer that has aftermarket electronic trailer brake controls. Failure to follow this instruction could result in the loss of control of your vehicle, personal injury or death.

 **WARNING:** Adaptive cruise control is not a crash warning or avoidance system.

 **WARNING:** Adaptive cruise control does not detect pedestrians or objects in the road.

 **WARNING:** Adaptive cruise control does not detect oncoming vehicles in the same lane.

 **WARNING:** Do not use the system in poor visibility, for example fog, heavy rain, spray or snow.

 **WARNING:** Do not use tire sizes other than those recommended because this can affect the normal operation of the system. Failure to do so may result in a loss of vehicle control, which could result in serious injury.

The system helps you to maintain a gap from the vehicle in front of you. The system adjusts your vehicle speed to maintain the set gap between you and the vehicle in front of you in the same lane. The system applies the brakes to slow your vehicle to maintain a safe gap distance from the vehicle in front.

The system uses a radar sensor which projects a beam directly in front of your vehicle.

The adaptive cruise controls are on the steering wheel.

### Switching Adaptive Cruise Control On



Press and release the switch.

The information display shows the grey indicator light. The system is now in standby.

# Cruise Control



E260516

The indicator, current gap setting and set speed appear in the information display.

## Setting the Adaptive Cruise Speed

Drive to the required speed.

**SET+** Press the toggle button upward to set the current speed.

Take your foot off the accelerator pedal.

A green indicator light, the current gap setting and the set speed appear in the information display.



E249552

A vehicle image displays if there is a vehicle detected in front of you.

**Note:** When adaptive cruise control is active, the speedometer may vary slightly from the set speed displayed in the information display.

## Following a Vehicle



**WARNING:** When following a vehicle, your vehicle does not decelerate automatically to a stop, nor does your vehicle always decelerate quickly enough to avoid a crash without driver intervention. Always apply the brakes when necessary. Failing to do so may result in a crash, serious injury or death.



**WARNING:** Adaptive cruise control only warns of vehicles detected by the radar sensor. In some cases there may be no warning or a delayed warning. You should always apply the brakes when necessary. Failure to do so may result in a crash, serious injury or death.

When a vehicle ahead of you enters the same lane or a slower vehicle is ahead in the same lane, the vehicle speed adjusts to maintain a preset gap distance.

**Note:** The brakes may emit noise when applied by the system.

The system may provide slight temporary acceleration when you use your driver side direction indicator while following a vehicle to aid passing the vehicle.

Your vehicle maintains a consistent gap from the vehicle ahead until:

- The vehicle in front of you accelerates to a speed above the set speed.
- The vehicle in front of you moves out of your lane or out of view.
- The vehicle speed falls below 20 km/h (12 mph).
- A new gap distance is set.

The system applies the brakes to slow the vehicle to maintain a safe distance from the vehicle in front. The system applies only limited maximum braking. Press the brake pedal to override the system.

# Cruise Control

If the system determines that its maximum braking level is not sufficient, an audible warning sounds and a message appears in the information display when the system continues to brake. You must take immediate action.

## Setting the Gap Distance

You can decrease or increase the distance between your vehicle and the vehicle in front by pressing the gap control.



Press and release to decrease the gap distance.



Press and release to increase the gap distance.

**Note:** It is your responsibility to select a gap appropriate to the driving conditions.



E249552

The selected gap appears in the information display as shown by the bars in the image. You can select four gap settings.

## Adaptive cruise control, distance between vehicle settings

Graphic display, bars indicated between vehicles	Distance gap	Dynamic behavior
1	Closest.	Sport.
2	Close.	Normal.
3	Medium.	Normal.
4	Furthest.	Comfort.

When you switch the ignition on, the system automatically selects the last chosen gap setting.

## Overriding the System



**WARNING:** If you override the system by pressing the accelerator pedal, it does not automatically apply the brakes to maintain a gap from any vehicle ahead.

Use the accelerator pedal normally to intentionally exceed the set speed limit.

When you override the system, the green indicator light illuminates and the vehicle graphic does not appear in the information display.

## Changing the Set Speed

**SET+**

Press the toggle button upward to increase the set speed.

**SET-**

Press the toggle button downward to decrease the set speed.

The set speed changes in small increments.

# Cruise Control

**Note:** Press and hold the toggle button upward or downward to change the set speed in larger increments.

The system may apply the brakes to slow the vehicle to the new set speed. The set speed displays continuously in the information display when the system is active.

## Canceling the Set Speed

**CAN**

Press and release the switch or tap the brake pedal.

The last set speed and gap setting displays in grey but does not erase.

**Note:** If you press the clutch pedal for an extended period, this action also cancels the set speed.

## Resuming the Set Speed

**RES**

Press and release the switch.

Your vehicle speed returns to the previously set speed and gap setting. The set speed shows continuously in the information display while the system is active.

**Note:** Only use resume if you are aware of the set speed and intend to return to it.

## Automatic Cancellation

The system is not functional at vehicle speeds below 20 km/h (12 mph). An audible alarm sounds and the automatic braking releases if the vehicle drops below this speed.

Automatic cancellation can also occur when:

- The tires lose traction.
- The engine speed is too low.
- You apply the parking brake.

**Note:** If the engine speed drops too low, the information display advises you to shift to a lower gear.

## Hilly Condition Usage

**Note:** An audible alarm sounds and the system shuts down if it applies brakes for an extended period of time. This allows the brakes to cool. The system functions normally again when the brakes have cooled.

You should select a lower gear when the system is active in situations such as prolonged downhill driving on steep grades, for example in mountainous areas. The system needs additional engine braking in these situations to reduce the load on the vehicle's regular brake system to prevent it from overheating.

## Switching Adaptive Cruise Control Off



Press and release the switch.

**Note:** You erase the set speed when you switch the system off.

## Detection Issues



**WARNING:** On rare occasions, detection issues can occur due to the road infrastructures, for example bridges, tunnels and safety barriers. In these cases, the system may brake late or unexpectedly. At all times, you are responsible for controlling your vehicle, supervising the system and intervening, if required.



**WARNING:** If the system malfunctions, have your vehicle checked as soon as possible.

# Cruise Control

The radar has a limited field of view. It does not detect all vehicles in all situations and could detect vehicles later than you expect. The lead vehicle image does not display if the system does not detect a vehicle in front of you.

**A**

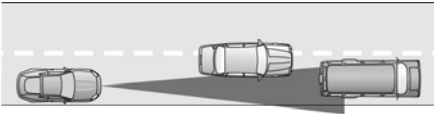

**B**

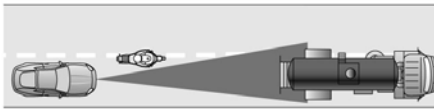

**C**

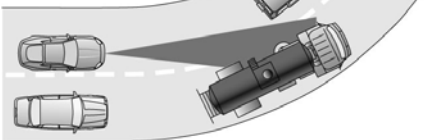

E71621

Detection issues can occur:

- A With vehicles that edge into your lane that can only be detected once they have moved fully into your lane.
- B Motorcyclists may be detected late, or not at all.
- C With vehicles in front of you when going into and coming out of a bend. The detection beam does not follow sharp curves in the road.

In these cases the system may brake late or unexpectedly. You should stay alert and intervene if necessary.

If something hits the front of your vehicle or damage occurs, the radar-sensing zone may change. This could cause missed or false vehicle detections. Contact an authorized dealer as soon as possible.

## System Not Available

The system may not turn on if there is:

- A blocked sensor.
- High brake temperature.
- A failure in the system or a related system.

## Blocked Sensor



E244279

A message displays if something obstructs the radar signals from the sensor. The sensor is behind the grille. The system cannot detect a vehicle ahead and does not function when something blocks the sensor.

**Note:** *You cannot see the sensor, it is behind a fascia panel.*

Keep the front of your vehicle free of dirt, metal badges or objects. Vehicle front protectors and aftermarket lights may also block the sensor.

# Cruise Control

Cause	Action
The surface of the radar in the grille is dirty or obstructed in some way.	Clean the radiator grille in front of the radar or remove any obstruction.
The surface of the radar is clean but the message remains in the display.	Wait a short period of time. It may take several minutes for the radar to detect that it is free from obstruction.
Heavy rain or snow interfere with the radar signals.	Do not use the system in these conditions because it may not detect any vehicles ahead.
Swirling water, snow or ice on the surface of the road interfere with the radar signals.	Do not use the system in these conditions because it may not detect any vehicles ahead.
You are in a desert or remote area with no other vehicles and no roadside objects.	Wait a short period of time or switch to normal cruise control.

It is possible to get a blockage warning and not be blocked. A false blocked condition self clears or clears after a key cycle.

Due to the nature of radar technology, you may get a blocked sensor warning when no obstruction blocks your sensor. This can happen, for example, when driving in sparse rural or desert environments. A false blocked condition either self clears or clears after a key cycle.



The gap setting does not display and the system does not respond to lead vehicles. Automatic braking remains active to maintain set speed.

## Switching to Normal Cruise Control



**WARNING:** Normal cruise control will not brake when your vehicle is approaching slower vehicles. Always be aware of which mode you have selected and apply the brakes when necessary.

You can change from adaptive cruise control to cruise control using the information display.

# Driving Aids

## SPEED LIMITER

### Principle of Operation



**WARNING:** When you are going downhill, your vehicle speed may increase above the set speed. The system will not apply the brakes but a warning displays. Failure to follow this warning could result in serious personal injury or death.

The system allows you to set a speed, to which your vehicle then becomes limited. The set speed will become the effective maximum speed of your vehicle, but with the option to temporarily exceed this limit if required.

### Using the System

**The system is operated by adjustment controls mounted on the steering wheel.**

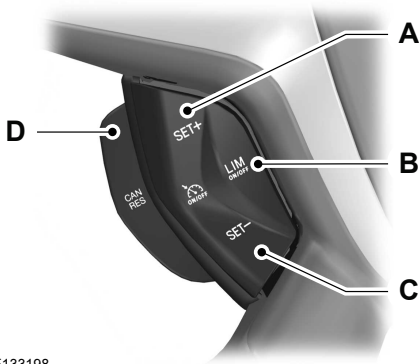

E133198

- A Set speed increase
- B On and off
- C Set speed decrease
- D Cancel and resume

**Note:** The set speed limit can be intentionally exceeded for a short period of time if required, for example when overtaking.

### Switching the System On and Off

Press switch B. The information display will prompt you to set a speed.

### Setting the Speed Limit

Press switch A or C with the limiter in standby mode to set the limiter to the current vehicle speed.

Press switch A or C to select your desired speed limit. The speed is displayed in the information display and stored as the set speed.

Pull switch D to cancel the limiter and place it in standby mode. The information display will confirm this has been turned off by showing the set speed crossed out.

Pull switch D again to resume the limiter. The information display will confirm this has been turned on by showing the set speed again.

### Intentionally Exceeding the Set Speed Limit

Depress the accelerator fully to temporarily switch the system off. The system will turn on once your vehicle speed drops below the set speed.

### System Warnings

If you accidentally exceed the set speed, the set speed indicator flashes in the information display and a warning tone sounds.

If you intentionally exceed the set speed, the set speed indicator flashes in the information display.

# Driving Aids

## INTELLIGENT SPEED LIMITER

### Principle of Operation



**WARNING:** When you are going downhill, your vehicle speed could increase above the set speed. The system does not apply the brakes.



**WARNING:** The system is designed to aid the driver. It is not intended to replace your attention and judgment. You are still responsible to drive with due care and attention.

The system allows you to limit the vehicle speed to the maximum speed limit detected by the traffic sign recognition system. For example, if the traffic sign recognition system detects a 80 km/h (50 mph) speed limit, the vehicle speed is limited to 80 km/h (50 mph). You can temporarily exceed the set speed if required, for example to overtake.

**Note:** *The system does not detect speed limits shown with a supplementary traffic sign.*

You can change between the speed limiter modes using the information display. See **General Information** (page 80).

You can set a permanent speed tolerance that is in addition to the detected speed limit through the tolerance menu in the information display. See **General Information** (page 80).

### Using Intelligent Speed Limiter

The controls are on the steering wheel.

### Switching the System On and Off

**LIM**

Press to set the system in standby mode. The system prompts you to set a speed or show the detected speed limit as the set speed. Press again to switch the system off.

**Note:** *The system does not limit the vehicle speed in standby mode.*

### Setting the Speed Limiter

**SET+**

Press the toggle button upward or downward with the system in standby mode to set the speed limiter to the current vehicle speed. The set speed is stored and displayed in the information

**SET-**

display.

**Note:** *The set speed limiter adjusts when the system detects a different maximum speed limit.*

**Note:** *If the system cannot detect a maximum speed limit, the system returns to standby mode.*

You can adjust the set speed in small or large increments. Press the toggle button upward or downward once to adjust the set speed in small increments. Press and hold the toggle button upward or downward to adjust the set speed in large increments.

### Canceling the Set Speed

**CAN**

Press to cancel the set speed limiter. The system returns to standby mode.

### Resuming the Set Speed

**RES**

Press to resume the set speed limiter. The system sets the speed limiter to the detected maximum speed limit at the time it resumes.

# Driving Aids

## Intentionally Exceeding the Speed Limit

Firmly press the accelerator pedal to temporarily exceed the set speed limit. The system resumes when the vehicle speed drops below the set speed limit, or when you press the **RES** button.

## System Warnings

A warning appears in the information display if any of the following occur:

- The vehicle speed exceeds the current set speed.
- The system detects a maximum speed limit that is lower than the current vehicle speed.
- You intentionally exceed the set speed.
- You unintentionally exceed the set speed, for example when you are going downhill. A tone also sounds.

**Note:** A tone sounds if you continue to exceed the set speed.

**Note:** If the traffic sign recognition system detects a speed limit outside the operational speed range, a tone sounds and the system returns to standby mode.

## DRIVER ALERT



**WARNING:** The system is designed to aid the driver. It is not intended to replace your attention and judgment. You are still responsible to drive with due care and attention.



**WARNING:** At all times, you are responsible for controlling your vehicle, supervising the system and intervening, if required. Failure to take care may result in the loss of control of your vehicle, serious personal injury or death.



**WARNING:** The system may not operate properly if the sensor is blocked. Keep the windshield free from obstruction.



**WARNING:** Take regular rest breaks if you feel tired. Do not wait for the system to warn you.



**WARNING:** Certain driving styles may result in the system warning you even if you are not feeling tired.



**WARNING:** In cold and severe weather conditions the system may not function. Rain, snow and spray can all limit sensor performance.



**WARNING:** The system will not operate if the sensor cannot track the road lane markings.



**WARNING:** If damage occurs in the immediate area surrounding the sensor, have your vehicle checked as soon as possible.



**WARNING:** The system may not correctly operate if your vehicle is fitted with a suspension kit not approved by us.

The system is designed to alert you if it calculates that you are becoming drowsy or if your driving deteriorates.

The system calculates your alertness level based upon your driving behavior in relation to the lane markings and other factors when the vehicle speed is greater than approximately 65 km/h (40 mph).

# Driving Aids

## Driver Alert System Warnings

The warning system has two stages:

1. A temporary warning is issued to advise you to take a rest. This message only appears for a short time.

2. If you do not rest and the system continues to detect that your driving deteriorates, it issues a further warning. This remains in the information display until you cancel it.

**Note:** *The system does not warn you if the vehicle speed falls below approximately 65 km/h (40 mph).*

## Driver Alert System Display

**To view the driver alert system status, use the information display controls on the steering wheel to select the following:**

Menu Item	Action
Settings	Press the menu button.
Information	Press the <b>OK</b> button.
Driver alert	Press the <b>OK</b> button.

Your calculated alertness level is shown by six steps as a colored bar. The bar travels from right to left as your calculated alertness level decreases.

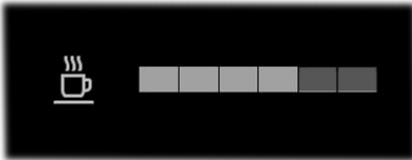

E249476

Your calculated alertness level is good.



E249477

Your calculated alertness level is low. You should stop your vehicle and take a rest as soon as it is safe to do so.

Your calculated alertness level shows in gray if:

- The sensor cannot track the road lane markings.
- The vehicle speed is less than approximately 65 km/h (40 mph).

# Driving Aids

## Switching Driver Alert On or Off

To switch driver alert on or off, use the information display controls on the steering wheel to select the following:

Menu Item	Action
Driver assist.	Press the menu button.
Driver alert	Press the <b>OK</b> button.

**Note:** The system remains on or off depending on how it was last set.

## Resetting Driver Alert

You can reset the system by:

- Switching the ignition off and on when your vehicle is stationary.
- Opening and closing the driver door when your vehicle is stationary.

## Driver Alert System Messages

Message	Action
Driver fatigue warning Rest suggested	Displays when we recommend that you take a break due to low alertness levels.
Driver fatigue warning Rest now	Displays when you must take a break due to low alertness levels.

## LANE KEEPING SYSTEM



**WARNING:** You are responsible for controlling your vehicle at all times. The system is designed to be an aid and does not relieve you of your responsibility to drive with due care and attention. Failure to follow this instruction could result in the loss of control of your vehicle, personal injury or death.



**WARNING:** The system may not function if the sensor is blocked.



**WARNING:** The sensor may incorrectly track lane markings as other structures or objects. This can result in a false or missed warning.



**WARNING:** In cold and severe weather conditions the system may not function. Rain, snow and spray can all limit sensor performance.



**WARNING:** Large contrasts in outside lighting can limit sensor performance.

# Driving Aids



**WARNING:** The system will not operate if the sensor cannot track the road lane markings.



**WARNING:** If damage occurs in the immediate area surrounding the sensor, have your vehicle checked as soon as possible.



**WARNING:** The system may not correctly operate if your vehicle is fitted with a suspension kit not approved by us.

The system is designed to alert you by providing temporary steering assistance or steering wheel vibration when it detects an unintended lane departure. The system detects and tracks the road lane markings using a camera mounted behind the interior mirror. The system only operates when the vehicle speed is greater than approximately 65 km/h (40 mph). You can view the system status in the information display.

**Note:** *The system works when the camera can detect at least one lane marking or the edge of the road.*

The system may not correctly operate in any of the following conditions:

- The system does not detect at least one lane marking or the edge of the road.
- You switch the direction indicator on.
- You apply direct steering, accelerate fast or brake hard.
- The vehicle speed is less than 65 km/h (40 mph).
- The anti-lock brake, stability control or traction control system activates.
- Narrow lane width.

The system may not correct lane positioning in any of the following conditions:

- High winds.
- Uneven road surfaces.
- Heavy or uneven loads.
- Incorrect tire pressure.

## Switching Lane Keeping System On or Off



E270719

Press the button on the direction indicator stalk.

## Lane Keeping System Settings

The system has different settings that you can view or adjust using the information display.

**Note:** *The system remembers the last setting when you start your vehicle. If the system detects a MyKey, the mode is set to alert.*

### Alert Mode

Provides steering wheel vibration when the system detects an unintended lane departure.

# Driving Aids

## Intensity Setting

To adjust the steering wheel vibration intensity setting, use the information display controls on the steering wheel to select the following:

Menu Item	Action
Driver assist.	Press the menu button.
Lane keeping system	Press the <b>OK</b> button.
Intensity	Press the <b>OK</b> button. Press the toggle button upward or downward to choose your required setting. Press the <b>OK</b> button.

**Note:** This setting does not affect the aid mode.

**Note:** The system remembers the last setting when you start your vehicle.

## Aid Mode

Provides temporary steering assistance toward the lane center when the system detects an unintended lane departure.

**Note:** When aid mode is on and the system does not detect any steering activity for a short period of time, for example lightly holding the steering wheel, the system alerts you to put your hands on the steering wheel.

## Alert and Aid Mode

Provides temporary steering assistance toward the lane center when the system detects an unintended lane departure. If your vehicle continues drifting out of the lane, the steering wheel vibrates.

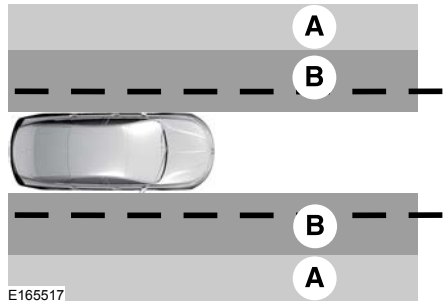

- A Alert mode.
- B Aid mode.

**Note:** The diagram illustrates general zone coverage. It does not provide exact zone parameters.

# Driving Aids

**To change between the lane keeping system modes, use the information display controls on the steering wheel to select the following:**

Menu Item	Action
Driver assist.	Press the menu button.
Lane keeping system	Press the <b>OK</b> button.
Mode	Press the <b>OK</b> button. Press the toggle button upward or downward to choose your required setting. Press the <b>OK</b> button.

## Lane Keeping System Display

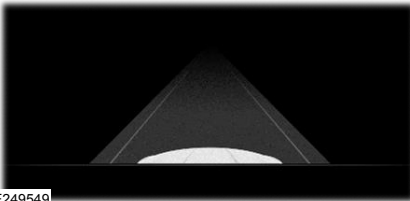

E249549

When the system is off, the system indicator or the lane markings do not display.

## Alert Mode



E249550

When you switch the system on, an indicator appears in the information display and a graphic showing the lane markings displays.

## Aid Mode



E249551

If you switch Aid Mode or Alert and Aid Mode on, arrows also display with the lane markings.

## Lane Keeping System Warning Lamps and Indicators

### Lane Keeping Alert Indicator



It illuminates when you switch the system on.

### Lane Keeping Aid Warning Lamp



It illuminates when the system activates.

# Driving Aids

## Black and White Information Display

Indicator	System Status
Gray.	Unavailable.
White.	Available.
White and inverted.	Temporary steering assistance.
White and flashing.	Temporary steering assistance and steering wheel vibration.

## Color Information Display

Indicator	System Status
Gray.	Unavailable.
Green.	Available.
Amber.	Temporary steering assistance.
Red.	Temporary steering assistance and steering wheel vibration.

## Lane Keeping System Messages

Message	Action
Lane keeping system malfunction Service required	The system has detected a fault that requires service. Have your vehicle checked as soon as possible.

## BLIND SPOT INFORMATION SYSTEM



**WARNING:** Do not use the blind spot information system as a replacement for using the interior and exterior mirrors or looking over your shoulder before changing lanes. The blind spot information system is not a replacement for careful driving.

# Driving Aids



**WARNING:** The system may not operate properly during severe weather conditions, for example snow, ice, heavy rain and spray. Always drive with due care and attention. Failure to take care may result in a crash.

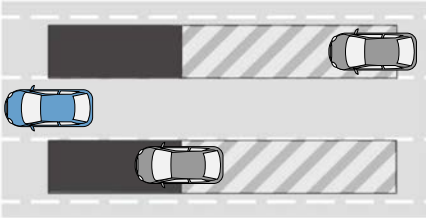

E255695

The system is designed to detect vehicles that may have entered the blind spot zone. The detection area is on both sides of your vehicle, extending rearward from the exterior mirrors to approximately 4 m (13 ft) beyond the rear bumper. The detection area extends to approximately 18 m (59 ft) beyond the rear bumper when the vehicle speed is greater than 48 km/h (30 mph) to alert you of faster approaching vehicles.

**Note:** *The system does not prevent contact with other vehicles. It is not designed to detect parked vehicles, pedestrians, animals or other infrastructures.*

## Using the Blind Spot Information System

### Vehicles with Automatic Transmission

The system turns on when all of the following occur:

- You start your vehicle.
- You shift into drive (D).
- The vehicle speed is greater than 10 km/h (6 mph).

**Note:** *The system does not operate in park (P) or reverse (R).*

### Vehicles with Manual Transmission

The system turns on when all of the following occur:

- You start your vehicle.
- The vehicle speed is greater than 10 km/h (6 mph).

**Note:** *The system does not operate in reverse (R).*

## System Lights and Messages



E142442

When the system detects a vehicle, an alert indicator illuminates in the exterior mirror on the side the approaching vehicle is coming from. If you turn the direction indicator on for that side of your vehicle, the alert indicator flashes.

# Driving Aids

**Note:** The system may not alert you if a vehicle quickly passes through the detection zone.

## Blocked Sensors



E205199

The sensors are behind the rear bumper on both sides of your vehicle.

**Note:** Keep the sensors free from snow, ice and large accumulations of dirt.

**Note:** Do not cover the sensors with bumper stickers, repair compound or other objects.

**Note:** Blocked sensors could affect system performance.

If the sensors become blocked, a message may appear in the information display. See **Information Messages** (page 82). The alert indicators remain illuminated but the system does not alert you.

## System Errors

If the system detects a fault, a warning lamp illuminates and a message displays. See **Information Messages** (page 82).

## Switching the System On and Off

You can switch the system off using the information display. See **General Information** (page 80). When you switch the system off, a warning lamp illuminates and a message displays. When you switch the system on or off, the alert indicators flash twice.

**Note:** The system remembers the last setting when you start your vehicle.

**Note:** The system may not correctly operate when towing a trailer. For vehicles with a trailer tow module and tow bar approved by us, the system turns off when you attach a trailer. For vehicles with an aftermarket trailer tow module or tow bar, we recommend that you switch the system off when you attach a trailer.

To permanently switch the system off, contact an authorized dealer.

## CROSS TRAFFIC ALERT



**WARNING:** Do not use the cross traffic alert system as a replacement for using the interior and exterior mirrors or looking over your shoulder before reversing out of a parking space. The cross traffic alert system is not a replacement for careful driving.



**WARNING:** The system may not operate properly during severe weather conditions, for example snow, ice, heavy rain and spray. Always drive with due care and attention. Failure to take care may result in a crash.

Cross Traffic Alert is designed to warn you of vehicles approaching from the sides when the transmission is in reverse (R).

## Using the System

Cross Traffic Alert turns on when you start the engine and you shift into reverse (R). Once shifted out of reverse (R), Cross Traffic Alert turns off.

**Note:** Cross Traffic Alert only functions while your transmission is in reverse (R).

# Driving Aids

Cross Traffic Alert is designed to detect vehicles that approach with a speed up to 60 km/h (37 mph). Coverage decreases when the sensors are partially, mostly or

fully obstructed. Reversing slowly helps increase the coverage area and effectiveness.

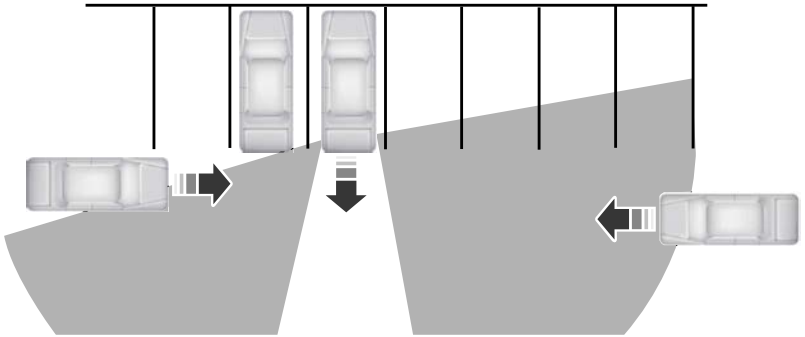

E142440

In this first example, the left sensor is only partially obstructed; zone coverage to the right is nearly maximized.

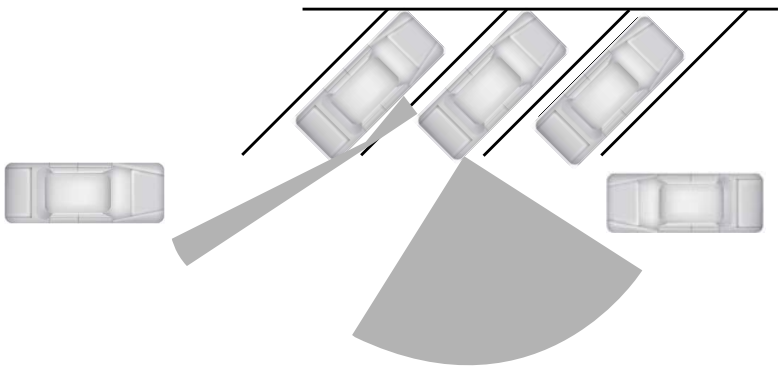

E142441

# Driving Aids

Zone coverage also decreases when parking at shallow angles. Here, the left sensor is mostly obstructed; zone coverage on that side is severely limited.

## System Lights, Messages and Audible Alerts



E142442

The Cross Traffic Alert illuminates an amber alert indicator in the outside mirror on the side of your vehicle the approaching vehicle is coming from. Cross Traffic Alert also sounds an audible alert and a message appears in the information display indicating a vehicle is coming from the right or left. Cross Traffic Alert works with the reverse sensing system that sounds its own series of tones. See **Rear Parking Aid** (page 169).

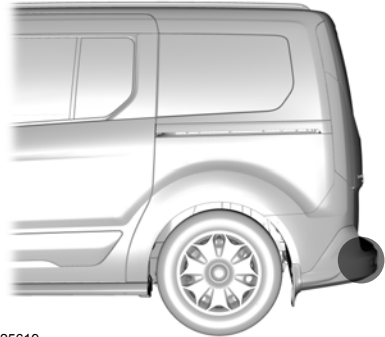

E225619

The system uses radar sensors that are located behind the bumper fascia on each side of your vehicle. Do not allow mud, snow or bumper stickers to obstruct these areas, this can cause degraded system performance. See **Blind Spot Information System** (page 200). If the Blind Spot Information System is blocked, Cross Traffic Alert is also blocked. A corresponding message appears in the information display as soon as you shift the transmission into reverse (R).

## System Limitations

Cross Traffic Alert has its limitations; situations such as severe weather conditions or debris build-up on the sensor area may limit vehicle detection.

The following are other situations that may limit the Cross Traffic Alert performance:

- Adjacently parked vehicles or objects obstructing the sensors.
- Approaching vehicles passing at speeds greater than 60 km/h (37 mph).
- Driving in reverse faster than 12 km/h (7 mph).
- Backing out of an angled parking spot.

## False Alerts

**Note:** *If your vehicle has a tow bar with a factory equipped trailer tow module and it is towing a trailer, the sensors will automatically turn the Cross Traffic Alert off. If your vehicle has a tow bar but no factory equipped trailer tow module, it is recommended to turn the Cross Traffic Alert off manually. Operating Cross Traffic Alert with a trailer attached will cause poor Cross Traffic Alert performance.*

There may be certain instances when there is a false alert by the Cross Traffic Alert system that illuminates the alert indicator with no vehicle in the coverage zone. Some amount of false alerts are normal; they are temporary and self-correct.

## System Errors

If Cross Traffic Alert senses a problem with the left or right sensor a message will appear in the information display. See **Information Messages** (page 82).

## Switching the System Off and On

You can temporarily switch Cross Traffic Alert off in the information display. See **General Information** (page 80). When you switch Cross Traffic Alert off, you will not receive alerts and the information display will display a system off message.

**Note:** *The Cross Traffic Alert switches on whenever the ignition is switched on and ready to provide appropriate alerts when the transmission is in reverse (R). Cross Traffic Alert will not remember the last selected on or off setting.*

You can also have Cross Traffic Alert switched off permanently at an authorized dealer. Once switched off permanently, the system can only be switched back on at an authorized dealer.

## TRAFFIC SIGN RECOGNITION

### Principle of Operation



**WARNING:** You are responsible for controlling your vehicle at all times. The system is designed to be an aid and does not relieve you of your responsibility to drive with due care and attention. Failure to follow this instruction could result in the loss of control of your vehicle, personal injury or death.



**WARNING:** The system may not operate properly if the sensor is blocked. Keep the windshield free from obstruction.

The system is designed to detect traffic signs to inform you of the current speed limit and overtaking regulations. Detected traffic signs appear in the information display. The sensor is behind the interior mirror.

**Note:** *Do not carry out windshield repairs in the immediate area surrounding the sensor.*

**Note:** *Traffic sign data provided by the navigation system contains information integrated to the data carrier release.*

The system detects recognizable traffic signs, for example:

- Speed limit signs.
- No overtaking signs.
- Speed limit cancellation signs.
- No overtaking cancellation signs.

**Note:** *The system may not detect all traffic signs and may incorrectly read signs.*

# Driving Aids

**Note:** In cold and severe weather conditions the system may not function. Rain, snow, spray and large contrasts in lighting can all prevent the sensor from correctly functioning.

**Note:** If your vehicle has a suspension kit not approved by us, the system may not correctly function.

**Note:** Always fit Ford original parts when replacing headlamp bulbs. Other bulbs may reduce system performance.

**To switch the system speed warning on or off, or to adjust the speed warning settings, use the information display controls on the steering wheel to select the following:**

Menu Item	Action
Driver assist.	Press the menu button.
Traffic sign recognition	Press the <b>OK</b> button.
Activate speed warning	Press the <b>OK</b> button.
Speed warning	Press the menu button.
Tolerance	Press the <b>OK</b> button. Press the toggle button upward or downward to choose your required speed setting. Press the <b>OK</b> button.
Overspeed chime	Press the <b>OK</b> button.

## Traffic Sign Recognition System Display



E132994

The system can display two traffic signs in parallel.

The system turns on when you switch the ignition on and you cannot switch the system off.

## Using Traffic Sign Recognition

### Setting the System Speed Warning

You can set the system speed warning to alert you when the vehicle speed exceeds the speed limit recognized by the system by a certain speed tolerance.

You can view the status at any time using the information display.

The system displays recognizable traffic signs in four stages as follows:

1. All new traffic signs appear brighter than the others in the display.
2. After a predetermined time they display normally.
3. After a predetermined distance they are greyed out.
4. After another predetermined distance they are deleted.

# Driving Aids

If the system detects a supplementary traffic sign, it displays below the respective traffic sign. For example, when passing a reduced speed limit in wet road conditions

sign.

**Note:** *If your vehicle has a navigation system, stored traffic sign data may influence the indicated speed limit value.*

## Traffic Sign Recognition System Messages

Message	Action
Traffic sign recognition Reduced performance See manual	The traffic sign data provided by the navigation system is unavailable due to weak or no signal. Wait for a short period of time for the signal to improve. If the message continues to appear, have your vehicle checked as soon as possible.

## SPEED SIGN RECOGNITION

### Principle of Operation

 **WARNING:** The system is designed to aid the driver. It is not intended to replace your attention and judgment. You are still responsible to drive with due care and attention.

 **WARNING:** At all times, you are responsible for controlling your vehicle, supervising the system and intervening, if required. Failure to take care may result in the loss of control of your vehicle, serious personal injury or death.

 **WARNING:** The system may not operate properly if the sensor is blocked. Keep the windshield free from obstruction.

The system is designed to detect speed limit signs to inform you of the current speed limit. Detected speed signs appear in the information display. The sensor is behind the interior mirror.

**Note:** *Do not carry out windshield repairs in the immediate area surrounding the sensor.*

**Note:** *Speed sign data provided by the navigation system contains information integrated to the data carrier release.*

**Note:** *The system may not detect all speed signs and may incorrectly read signs.*

**Note:** *In cold and severe weather conditions the system may not function. Rain, snow, spray and large contrasts in lighting can all prevent the sensor from correctly functioning.*

**Note:** *If your vehicle has a suspension kit not approved by us, the system may not correctly function.*

**Note:** *Always fit Ford original parts when replacing headlamp bulbs. Other bulbs may reduce system performance.*

The system turns on when you switch the ignition on and you cannot switch the system off.

### Using Speed Sign Recognition

#### Setting the System Speed Warning

You can set the system speed warning to alert you when the vehicle speed exceeds the speed limit recognized by the system by a certain speed tolerance.

# Driving Aids

**To switch the system speed warning on or off, or to adjust the speed warning settings, use the information display controls on the steering wheel to select the following:**

Menu Item	Action
Driver assist.	Press the menu button.
Speed sign recognition	Press the <b>OK</b> button.
Activate speed warning	Press the <b>OK</b> button.
Speed warning	Press the <b>OK</b> button.
Tolerance	Press the <b>OK</b> button. Press the toggle button upward or downward to choose your required speed setting. Press the <b>OK</b> button.

## Speed Sign Recognition System Display

When the system detects a speed limit sign, the speed limit appears in the information display.

**Note:** If your vehicle has a navigation system, stored speed sign data could influence the indicated speed limit value.

## ECO MODE

### Principle of Operation

The system is designed to monitor certain driving characteristics to help you drive more efficiently. See **Economical Driving** (page 224).

**Note:** The efficiency levels do not result in a defined fuel consumption figure. See **Fuel Consumption** (page 148).

**Note:** The system only indicates the efficiency level for the current trip. The system resets each time you switch the ignition on.

### Eco Mode System Display

You can view the instantaneous efficiency level or the trip summary in the information display.

### Instantaneous Efficiency Level

The display ring increases as the instantaneous efficiency level increases and illuminates when it reaches maximum efficiency. The level continuously updates to indicate the efficiency level for the current trip.

**To view the instantaneous efficiency level, use the information display controls on the steering wheel to select the following:**

Menu Item	Action
MyView	Press the menu button.
Eco coach	Press the <b>OK</b> button.

# Driving Aids

## Trip Summary

The calculated trip summary is shown as four colored bars. The bars travel from left to right as the calculated efficiency levels increase. The bars indicate the average efficiency level for acceleration,

deceleration, speed and gear shifting during the total distance traveled by your vehicle for the current trip.

**Note:** *Vehicles with an automatic transmission do not have a bar for gear shifting.*

**To view the trip summary, use the information display controls on the steering wheel to select the following:**

Menu Item	Action
MyView	Press the menu button.
Eco coach	Press the <b>OK</b> button. Press it again to view the trip summary.

## PRE-COLLISION ASSIST



**WARNING:** You are responsible for controlling your vehicle at all times. The system is designed to be an aid and does not relieve you of your responsibility to drive with due care and attention. Failure to follow this instruction could result in the loss of control of your vehicle, personal injury or death.



**WARNING:** The system does not operate during hard acceleration or steering. Failure to take care may lead to a crash or personal injury.



**WARNING:** The system may fail or operate with reduced function during cold and severe weather conditions. Snow, ice, rain, spray and fog can adversely affect the system. Keep the front camera and radar free of snow and ice. Failure to take care may result in the loss of control of your vehicle, serious personal injury or death.



**WARNING:** The system may not operate properly if your vehicle has a non-Ford windshield. Do not carry out windshield repairs in the area around the sensor.



**WARNING:** In situations where the vehicle camera has limited detection capability, this may reduce system performance. These situations include but are not limited to direct or low sunlight, vehicles at night without tail lights, unconventional vehicle types, pedestrians with complex backgrounds, running pedestrians, partly obscured pedestrians, or pedestrians that the system cannot distinguish from a group. Failure to take care may result in the loss of control of your vehicle, serious personal injury or death.



**WARNING:** The Pre-Collision Assist system with brake support cannot help prevent all collisions. Do not rely on this system to replace your judgment and the need to maintain correct distance and speed.

# Driving Aids

The pre-collision assist system is active when your vehicle reaches a speed greater than approximately 5 km/h (3 mph). Pedestrian detection is active at speeds up to 80 km/h (50 mph).

**Note:** *The system is not designed to detect animals.*

**Note:** *The system is not designed to detect vehicles or cyclists that are traveling in a different direction.*

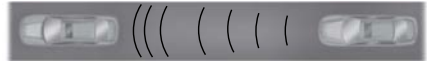

E156130

If your vehicle is rapidly approaching a stationary vehicle, a vehicle or cyclist traveling in the same direction as yours, or a pedestrian within your driving path, the system is designed to provide three levels of functionality.

Level of Functionality	Description
Alert	When activated, a warning lamp flashes and an audible warning sounds.
Brake support	The system is designed to help reduce the impact speed by preparing the brakes for rapid braking. The system does not automatically apply the brakes. If you press the brake pedal, the system could apply additional braking up to maximum braking force, even if you lightly press the brake pedal.
Active braking - vehicles without adaptive cruise control	The system is designed to apply the brakes if it detects a crash is imminent. This may help reduce impact or avoid the crash. The system is active at speeds up to 130 km/h (80 mph).
Active braking - vehicles with adaptive cruise control	The system is designed to apply the brakes if it detects a crash is imminent. This may help reduce impact or avoid the crash.

**To switch active braking on or off, use the information display controls on the steering wheel to select the following:**

Menu Item	Action
Driver assist.	Press the menu button.
Pre-collision Assist	Press the <b>OK</b> button.
Active braking	Press the <b>OK</b> button.

## Distance Alert

A warning lamp illuminates if the distance to the vehicle ahead is small.

**Note:** *The warning lamp does not illuminate if cruise control or adaptive cruise control is active.*

# Driving Aids

## Distance Alert Sensitivity Settings

To adjust the distance alert sensitivity settings, use the information display controls on the steering wheel to select the following:

Menu Item	Action
Driver assist.	Press the menu button.
Pre-collision Assist	Press the <b>OK</b> button.
Alert sensitivity	Press the <b>OK</b> button. Press the toggle button upward or downward to choose your required setting. Press the <b>OK</b> button.

## Distance Indication

A graphical indication displays the time gap to vehicles ahead of you traveling in the same direction.

**Note:** The graphic does not display if you switch on cruise control or adaptive cruise control.

Vehicle Speed	System Sensitivity	Distance Indicator Color	Distance Gap	Time Gap
100 km/h (62 mph)	Normal.	Gray.	Greater than 25 m (82.0 ft) .	Greater than 0.9 seconds.
		Yellow.	17–25 m (55.8–82.0 ft)	0.6-0.9 seconds.
		Red.	Less than 17 m (55.8 ft).	Less than 0.6 seconds.

## Switching Distance Indication On or Off

To switch distance indication on or off, use the information display controls on the steering wheel to select the following:

Menu Item	Action
Driver assist.	Press the menu button.
Pre-collision Assist	Press the <b>OK</b> button.
Distance indication	Press the <b>OK</b> button.

# Driving Aids

## Pre-Collision Assist System Sensors

### Vehicles without Adaptive Cruise Control



E243054

The camera is mounted behind the interior mirror.

**Note:** Keep the sensors free from snow, ice and large accumulations of dirt.

**Note:** Do not clean the sensors with sharp objects.

**Note:** If your vehicle sustains damage leaving the sensors misaligned, this may cause inaccurate measurements or false alerts.

Blocked sensors could affect system accuracy. A message may appear in the information display.

### Vehicles with Adaptive Cruise Control

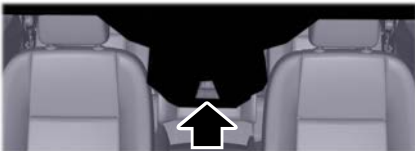

E243054

The camera is mounted behind the interior mirror.



E244279

The radar sensor is behind the front grille below the license plate.

**Note:** Keep the sensors free from snow, ice and large accumulations of dirt.

**Note:** Do not clean the sensors with sharp objects.

**Note:** If your vehicle sustains damage leaving the sensors misaligned, this may cause inaccurate measurements or false alerts.

Blocked sensors could affect system accuracy. A message may appear in the information display.

## Pre-Collision Assist Warning Lamp



It illuminates if your vehicle rapidly approaches another vehicle, to warn you of the risk of a crash with the vehicle in front of you.

It could illuminate red if the distance to the vehicle ahead is small.

It illuminates amber when you switch the system off.

# Driving Aids

## Pre-Collision Assist Information Messages

Message	Action
Pre-collision assist not available	The system has malfunctioned. Have your vehicle checked as soon as possible.
Pre-collision assist not available Sensor blocked	The sensors are dirty. Clean the sensors. If the message continues to appear, have your vehicle checked as soon as possible.

**The following table lists possible causes and actions for when a blocked sensor message may display.**

Cause	Action
The surface of the radar in the radiator grille is dirty or obstructed.	Clean the radiator grille in front of the radar or remove any obstruction.
The surface of the radar is clean but the message remains in the display.	Wait for a short period of time. It may take several minutes for the system to detect that there is no obstruction.
Heavy rain, spray, snow, or fog is interfering with the radar signals.	The system is temporarily disabled. The system should reactivate after a short period of time when the weather conditions improve.
The radar is misaligned.	Have your vehicle checked as soon as possible.
The windshield in front of the camera is dirty or obstructed.	Clean the outside of the windshield in front of the camera.
The windshield in front of the camera is clean but the message remains in the display.	Wait for a short period of time. It may take several minutes for the camera to detect that there is no obstruction.
Excessive heat around the camera.	Wait for a short period of time. The message should clear when the temperature around the camera decreases.

# Load Carrying

## GENERAL INFORMATION

**WARNING:** Make sure that you properly secure objects in the luggage compartment. Failure to follow this instruction could result in personal injury in the event of a sudden stop or crash.

**WARNING:** Do not place objects on the luggage cover. Failure to follow this instruction could result in personal injury or death in the event of a sudden stop or crash.

**WARNING:** The appropriate loading capacity of your vehicle can be limited either by volume capacity (how much space is available) or by payload capacity (how much weight the vehicle should carry). Once you have reached the maximum payload of your vehicle, do not add more cargo, even if there is space available. Overloading or improperly loading your vehicle can contribute to loss of vehicle control and vehicle rollover.

**WARNING:** Make sure that you fully close the liftgate to prevent exhaust fumes from entering your vehicle. If you are unable to fully close the liftgate, open the air vents or the windows to allow fresh air to enter your vehicle. Failure to follow this instruction could result in personal injury or death.

**WARNING:** Do not exceed the maximum front and rear axle loads for your vehicle.

**Note:** When loading long objects into your vehicle, for example pipes, timber or furniture be careful not to damage the interior trim.

## LUGGAGE ANCHOR POINTS

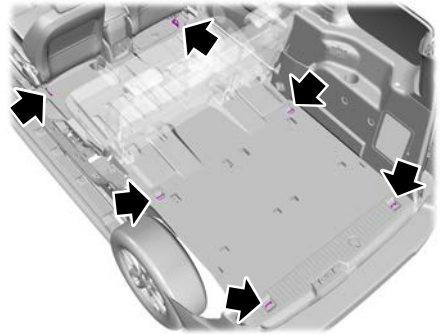

E167350

# Load Carrying

Maximum Load Value
3,000 N (675 lb)

## REAR UNDER FLOOR STORAGE

### Passenger Compartment Floor (If Equipped)



E78097

The under floor storage compartment is located behind the front passenger seat.

### Adjustable Load Floor (If Equipped)

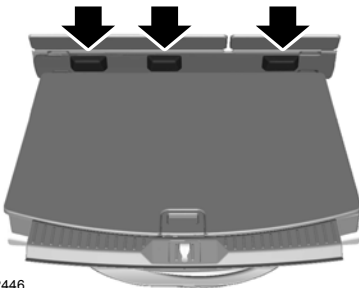



E142446

Vehicles with the standard size spare tire can adjust the load floor to two positions. The front of the load floor can be placed either on (for high position) or below (for low position) the ledges behind the rear seats. The rear of the load floor always sits on the two small shelves located on the liftgate trim.

## CARGO NETS

### Installing the Net (If Equipped)

 **WARNING:** Always attach and tighten the net to the luggage anchor points and do not put more than 10 kg (22 lb) of cargo behind the net and above the seat back. Otherwise, the net could fail and cargo could become a projectile, which could cause serious injury.

 **WARNING:** Do not allow people to ride in the third row seating positions when the cargo net is installed behind the second row. Failure to do so may limit egress from the vehicle in an emergency.

# Load Carrying

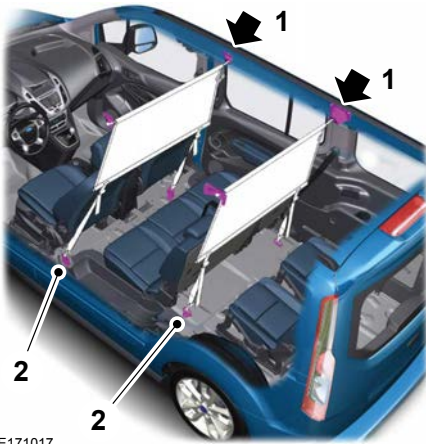

E171017

1. Push the ends of the upper bar toward each other and insert them into the retainers in the roof. Push the bar forward into the narrow section of the retainers.

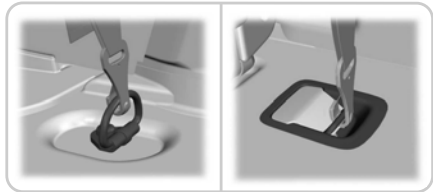
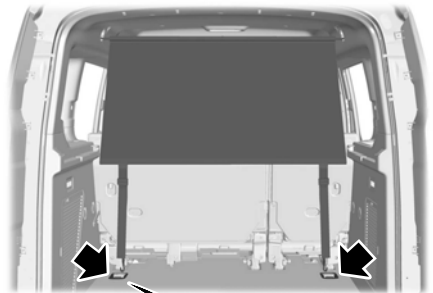

E167370

2. Attach the net to the luggage anchor points. See **Luggage Anchor Points** (page 214).

# Load Carrying

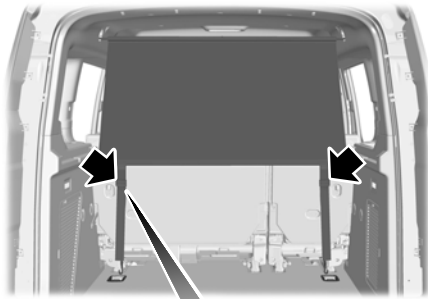

E167371

3. Tighten the straps.

## Removing the Net

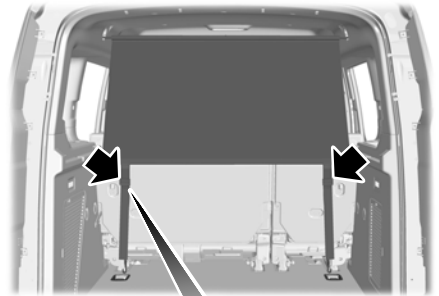

E167372

1. Release the straps.
2. Remove the net from the luggage anchor points.
3. Remove the upper bars.

## ROOF RACKS AND LOAD CARRIERS



**WARNING:** Read and follow the manufacturer's instructions when you are fitting a roof rack. Failure to take care may lead to a crash or personal injury.

# Load Carrying



**WARNING:** When loading the roof rack we recommend you evenly distribute the load, as well as maintain a low center of gravity. Loaded vehicles, with high centers of gravity handle differently than unloaded vehicles. Take extra precautions, use slower speeds and increased stopping distances. Failure to take care may result in the loss of control of your vehicle, serious personal injury or death.

For correct roof rack system function, you must place loads directly on crossbars fitted to the roof rack side rails. When using the roof rack system, we recommend you use Ford genuine accessory crossbars designed specifically for your vehicle.

Make sure that you securely fasten the load. Check the tightness of the load before driving and at each fuel stop.

**Note:** *If you use a roof rack, the fuel consumption of your vehicle will be higher and you may experience different driving characteristics.*

**Note:** *Never place loads directly on the roof panel.*

## Maximum Load Weights

**Do not exceed the following maximum roof rack load weights.**

Variant	Maximum Load kg (lb)*
Kombi	75 (165)
Van	100 (220)
Double Cab	100 (220)

\*Evenly distribute the load on the roof rack.

## FOLDING BULKHEAD

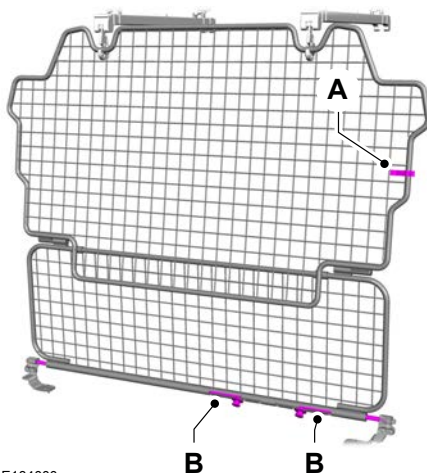

E184000

- A Folded position stay clip.
- B Locking pins.

## Moving the Folding Bulkhead to the Forward Position

1. Fold the second row seat backrests down. See **Rear Seats** (page 113).

# Load Carrying

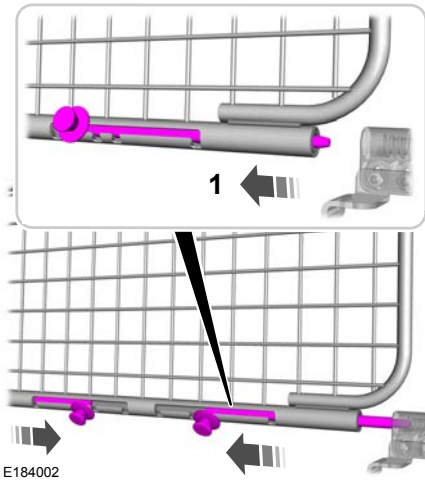

2. Slide the locking pins toward the center of your vehicle.

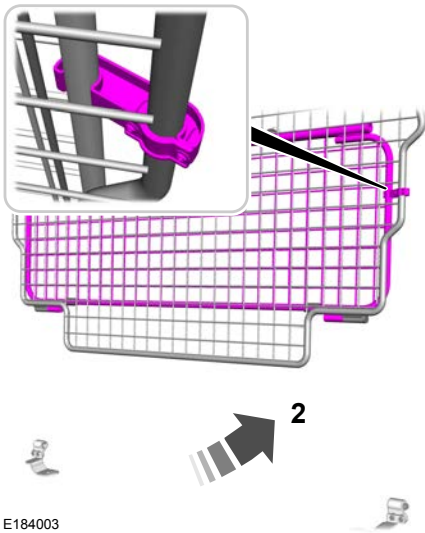

3. Fold the lower half of the folding bulkhead up. Use the folded position stay clip to secure it in place.

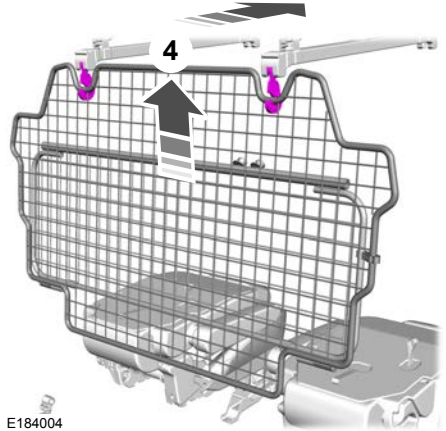

4. Lift the folding bulkhead up and slide it forward. Make sure that you locate it in the forward securing points.

**Note:** Tilt the folding bulkhead so that it slides in place free from obstruction.

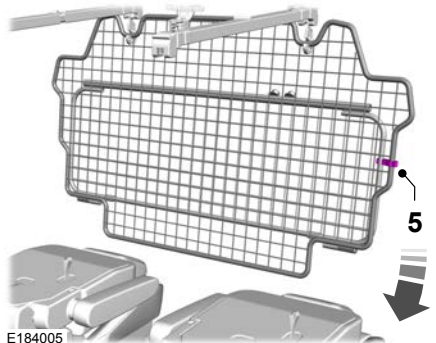

5. Disengage the folded position stay clip and unfold the lower half of the folding bulkhead down.

# Load Carrying

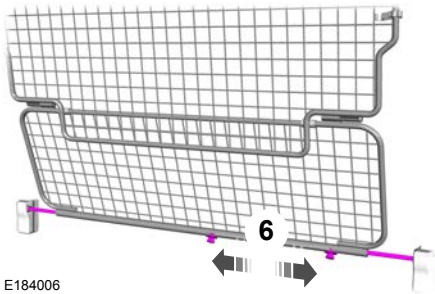

E184006

6. Slide the locking pins toward the outside of your vehicle. Make sure that you fully engage the catches.

## Moving the Folding Bulkhead Back to the Rearward Position

1. Slide the locking pins toward the center of your vehicle.
2. Fold the lower half of the folding bulkhead up. Use the folded position stay clip to secure it in place.
3. Lift the folding bulkhead up and slide it backward. Make sure that you locate it in the rearward securing points.

**Note:** *Tilt the folding bulkhead so that it slides in place free from obstruction.*

4. Disengage the folded position stay clip and unfold the lower half of the folding bulkhead down.
5. Slide the locking pins toward the outside of your vehicle. Make sure that you fully engage the catches.
6. Unfold the second row seat backrests. See **Rear Seats** (page 113).

# Towing

## TOWING A TRAILER



**WARNING:** Do not exceed 100 km/h (60 mph). Failure to follow this instruction could result in the loss of control of your vehicle, personal injury or death.



**WARNING:** The rear tire pressures must be increased by 0.2 bar (3 psi) above specification. Do not exceed the maximum pressure stated on the tire sidewall. This could cause serious personal injury.



**WARNING:** Do not exceed the maximum gross vehicle weight stated on the vehicle identification plate. Failure to follow this instruction could result in personal injury.



**WARNING:** Towing trailers beyond the maximum recommended gross trailer weight exceeds the limit of your vehicle and could result in engine damage, transmission damage, structural damage, loss of vehicle control, vehicle rollover and personal injury.



**WARNING:** Do not exceed the maximum vertical load on the tow ball. Failure to follow this instruction could result in the loss of control of your vehicle, personal injury or death.



**WARNING:** The anti-lock brake system does not control the trailer brakes.

When towing a trailer:

- Obey country specific regulations for towing a trailer.
- Do not exceed 100 km/h (62 mph) even if a country allows higher speeds under certain conditions.
- Place loads as low as possible and central to the axle of your trailer. If you are towing with an unloaded vehicle, you should place the load in your trailer toward the front, within the maximum vertical load, as this gives the best stability. See **Capacities and Specifications** (page 282).
- The trailer vertical weight on the tow ball is essential for the driving stability of your vehicle and trailer.
- The vertical weight on the tow ball should be at least 4% of the trailer weight and not exceed the maximum permissible weight. See **Capacities and Specifications** (page 282).
- Reduce speed immediately if the trailer shows any sign of swaying. See **Trailer Sway Control** (page 222).
- Use a low gear when descending a steep downhill gradient.

**Note:** We recommend that you use a trailer safety cable. Read and follow the manufacturer's instructions when you use a trailer safety cable.

**Note:** The maximum permissible trailer vertical weight on the trailer identification plate is the trailer manufacturer's testing value. The vehicle maximum permissible trailer vertical weight may be lower.

The stability of your vehicle-to-trailer combination depends on the quality of the trailer.

Towing a trailer changes the handling characteristics of your vehicle and increases stopping distances. Adapt your speed and driving behavior according to the trailer load.

# Towing

The gross train weight stated on the vehicle identification plate applies for road gradients up to 12% and altitudes up to 1,000 m (3,281 ft) when towing a trailer. In mountainous regions the engine performance decreases due to lower air density with increasing altitude. In high altitude regions above 1,000 m (3,281 ft), you should reduce the stipulated maximum permitted gross train weight by 10% for every additional 1,000 m (3,281 ft).

**Note:** *Not all vehicles are suitable or approved to have a tow bar fitted. Ask an authorized dealer for more information.*

## TRAILER SWAY CONTROL

If the trailer begins to sway, the stability control warning lamp flashes and a message appears in the information display. The system applies the brakes to the individual wheels and reduces engine torque to aid vehicle stability.

Stop your vehicle as soon as it is safe to do so. Check the vertical weight on the tow ball and trailer load distribution. See **Capacities and Specifications** (page 282). See **Load Carrying** (page 214).

**Note:** *This feature does not prevent trailer sway, but reduces it once it begins.*

**Note:** *This feature cannot stop all trailers from swaying.*

**Note:** *In some cases, if your vehicle speed is too high, the system may turn on multiple times, gradually reducing your vehicle speed.*

## TOWING THE VEHICLE ON FOUR WHEELS - MANUAL TRANSMISSION



**WARNING:** You must switch the ignition on when your vehicle is being towed. Failure to follow this warning could seriously increase the risk of injury or death.



**WARNING:** The brake and steering assistance will not operate unless the engine is running. Press the brake pedal harder and be aware of increased stopping distances and heavier steering.



**WARNING:** If your vehicle has a steering wheel lock make sure the ignition is in the accessory or on position when being towed.



**WARNING:** Too much tension on a tow rope could cause damage to your vehicle or the vehicle that is towing.



**WARNING:** When towing your vehicle you must select neutral. Failure to follow this warning could damage the transmission and may lead to a crash or injury.

Drive off slowly and smoothly without jerking the vehicle you are towing.

You must only use the towing eye that was delivered with your vehicle. See **Towing Points** (page 230).

Tow ropes or rigid towing bars must be placed on the same side. For example; right hand rear towing point to right hand front towing point.

# Towing

You must use a tow rope or rigid towing bar that is of the correct strength for the weight of the towing vehicle and the vehicle that is being towed.

The weight of the vehicle that is being towed must not exceed the weight of the towing vehicle.

Do not exceed 50 km/h (31 mph). See **Towing the Vehicle on Four Wheels** (page 222).

## TOWING THE VEHICLE ON FOUR WHEELS - AUTOMATIC TRANSMISSION



**WARNING:** You must switch the ignition on when your vehicle is being towed. Failure to follow this warning could seriously increase the risk of injury or death.



**WARNING:** If your vehicle has a steering wheel lock make sure the ignition is in the accessory or on position when being towed.



**WARNING:** You must make sure the transmission selector lever is placed in position **N**. Failure to follow this warning could damage the transmission and may lead to a crash or injury.



**WARNING:** The brake and steering assistance will not operate unless the engine is running. Press the brake pedal harder and be aware of increased stopping distances and heavier steering.



**WARNING:** Too much tension on a tow rope could cause damage to your vehicle or the vehicle that is towing.



**WARNING:** Do not tow your vehicle if the ambient temperature is below 0°C (32°F).

### Emergency Towing

If your vehicle is disabled without access to wheel dollies, a car-hauling trailer, or a flatbed transport vehicle it can be flat-towed with all wheels on the ground.

You may do this under the following conditions:

- Your vehicle is facing forward so that it is towed in a forward direction.
- The transmission selector lever is placed in position **N**. If the transmission gear shift lever cannot be moved to position **N**, it may need to be overridden. See **Automatic Transmission** (page 160).
- Maximum speed is 50 km/h (31 mph).
- Maximum distance is 80 km (50 mi).

Drive off slowly and smoothly without jerking the vehicle you are towing.

You must only use the recovery hook that was delivered with your vehicle. See **Towing Points** (page 230).

Tow ropes or rigid towing bars must be placed on the same side. For example; right hand rear towing point to right hand front towing point.

You must use a tow rope or rigid towing bar that is of the correct strength for the weight of the towing vehicle and the vehicle that is being towed.

**Note:** *Using a rigid towing bar is the safest way to tow a vehicle.*

The weight of the vehicle that is being towed must not exceed the weight of the towing vehicle.

# Driving Hints

## BREAKING-IN

### Tires

New tires need to be run-in for approximately 500 km (300 mi). During this time, you may experience different driving characteristics.

### Brakes and Clutch

Avoid heavy use of the brakes and clutch if possible for the first 150 km (100 mi) in town and for the first 1,500 km (1,000 mi) on freeways.

### Engine

Avoid driving too fast during the first 1,500 km (1,000 mi). Vary your speed frequently and change up through the gears early. Do not labor the engine.

### Vehicles With a Diesel Engine

During the first 3,000 km (2,000 mi), you may notice a ticking sound when your vehicle slows down. This is due to adjustments of your new diesel engine and is normal.

## REDUCED ENGINE PERFORMANCE



**WARNING:** If you continue to drive your vehicle when the engine is overheating, the engine could stop without warning. Failure to follow this instruction could result in the loss of control of your vehicle.

If the engine coolant temperature gauge needle moves to the upper limit position, the engine is overheating. See **Gauges** (page 75).

You must only drive your vehicle for a short distance if the engine overheats. The distance you can travel depends on ambient temperature, vehicle load and terrain. The engine continues to operate with limited power for a short period of time.

If the engine temperature continues to rise, the fuel supply to the engine reduces. The air conditioning switches off and the engine cooling fan operates continually.

1. Gradually reduce your speed and stop your vehicle as soon as it is safe to do so.
2. Immediately switch the engine off to prevent severe engine damage.
3. Wait for the engine to cool down.
4. Check the coolant level. See **Engine Coolant Check** (page 246).
5. Have your vehicle checked as soon as possible.

## ECONOMICAL DRIVING

The following helps to improve fuel consumption:

- Regularly check your tire pressures and make sure that they are inflated to the correct pressure. See **Tire Pressures** (page 276).
- Follow the recommended maintenance schedule and carry out the recommended checks.
- Plan your journey and check the traffic before you set off.
- Avoid idling the engine in cold weather or for extended periods. Start the engine only when you are ready to set off.
- Do not carry unnecessary weight in your vehicle as extra weight wastes fuel.

# Driving Hints

- Do not add unnecessary accessories to the exterior of your vehicle, for example running boards. If you use a roof rack, remember to fold it down or remove it when not in use.
- Drive smoothly, accelerate gently and anticipate the road ahead to avoid heavy braking.
- Switch off all electric systems when not in use, for example air conditioning. Make sure that you unplug any accessories from the auxiliary power points when not in use.

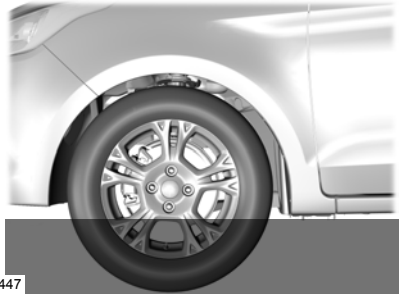

E266447

## COLD WEATHER PRECAUTIONS

The functional operation of some components and systems can be affected at temperatures below  $-25^{\circ}\text{C}$  ( $-13^{\circ}\text{F}$ ).

## DRIVING THROUGH WATER



**WARNING:** Do not drive through flowing or deep water as you may lose control of your vehicle.

**Note:** *Driving through standing water can cause vehicle damage.*

**Note:** *Engine damage can occur if water enters the air filter.*

Before driving through standing water, check the depth. Never drive through water that is higher than the bottom of the front rocker area of your vehicle.

When driving through standing water, drive very slowly and do not stop your vehicle. Your brake performance and traction may be limited. After driving through water and as soon as it is safe to do so:

- Lightly press the brake pedal to dry the brakes and to check that they work.
- Check that the horn works.
- Check that the exterior lights work.
- Turn the steering wheel to check that the steering power assist works.

## FLOOR MATS





**WARNING:** Use a floor mat designed to fit the footwell of your vehicle that does not obstruct the pedal area. Failure to follow this instruction could result in the loss of control of your vehicle, personal injury or death.



**WARNING:** Pedals that cannot move freely can cause loss of vehicle control and increase the risk of serious personal injury.

# Driving Hints

 **WARNING:** Secure the floor mat to both retention devices so that it cannot slip out of position and interfere with the pedals. Failure to follow this instruction could result in the loss of control of your vehicle, personal injury or death.

 **WARNING:** Do not place additional floor mats or any other covering on top of the original floor mats. This could result in the floor mat interfering with the operation of the pedals. Failure to follow this instruction could result in the loss of control of your vehicle, personal injury or death.

 **WARNING:** Always make sure that objects cannot fall into the driver foot well while your vehicle is moving. Objects that are loose can become trapped under the pedals causing a loss of vehicle control.



E142666

To install the floor mats, position the floor mat eyelet over the retention post and press down to lock in position.

To remove the floor mat, reverse the installation procedure.

**Note:** Regularly check the floor mats to make sure they are secure.

# Roadside Emergencies

## HAZARD FLASHERS



The hazard flasher switch is on the instrument panel.

Use the hazard flashers if your vehicle is creating a safety hazard for other road users.

### Switching the Hazard Flashers On or Off



Press the button to switch the hazard flashers on.

Press the button again to switch the hazard flashers off.

**Note:** All direction indicators flash.

**Note:** Prolonged use of the hazard flashers could cause the vehicle battery to run out of charge.

**Note:** Depending on applicable laws in the country your vehicle was built for, if you heavily brake, the hazard flashers could turn on.

### Hazard Flasher Indicator



Flashes when you switch the hazard flashers on.

## FIRST AID KIT

Space is provided in the overhead console or lower door bins.

## WARNING TRIANGLE

Space is provided in the overhead console or lower door bins.

## FUEL SHUTOFF

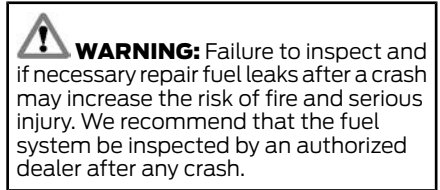

**WARNING:** Failure to inspect and if necessary repair fuel leaks after a crash may increase the risk of fire and serious injury. We recommend that the fuel system be inspected by an authorized dealer after any crash.

In the event of a moderate to severe crash, your vehicle is fitted with a fuel pump shut-off feature that stops the flow of fuel to the engine. Not every impact will cause a shut-off.

Should the engine turn off after a crash, you may restart the engine by carrying out the following.

### Ignition Switch

1. Switch the ignition off.
2. Switch the ignition to position **III**.
3. Switch the ignition off.
4. Switch the ignition on again to re-enable the fuel pump.

**Note:** Various system checks are automatically carried out before the vehicle will restart. If your vehicle fails to restart after the third attempt, the system has detected a fault that requires service. We recommend you contact an authorized dealer.

### Keyless Starting (If Equipped)

1. Without applying the brake pedal, press and release the button once.
2. Press the brake pedal, and then press and release the button once.
3. Without applying the brake pedal, press and release the button once.
4. Press the brake pedal, and then press and hold the button until the engine starts.

# Roadside Emergencies

**Note:** Various system checks are automatically carried out before the vehicle will restart. If your vehicle fails to restart after the third attempt, the system has detected a fault that requires service. We recommend you contact an authorized dealer.

## JUMPSTARTING THE VEHICLE

**WARNING:** The gases around the battery can explode if exposed to flames, sparks or lit cigarettes. An explosion could result in personal injury or vehicle damage.

**WARNING:** Batteries contain sulfuric acid which can burn skin, eyes and clothing, if contacted.

**WARNING:** Use only an adequate-sized cable with insulated clamps.

**Note:** Do not disconnect the battery from your vehicle's electrical system.

### Preparing Your Vehicle

**Note:** Do not attempt to push-start your automatic transmission vehicle. Automatic transmissions do not have push-start capability. Attempting to push-start a vehicle with an automatic transmission may cause transmission damage.

**Note:** Use only a 12-volt supply to start your vehicle.

**Note:** Do not disconnect the battery of the disabled vehicle as this could damage the vehicle's electrical system.

Park the booster vehicle close to the hood of the disabled vehicle, making sure the two vehicles do not touch, and switch off all accessories.

## Connecting the Jumper Cables

**WARNING:** Do not attach the cables to fuel lines, engine rocker covers, the intake manifold or electrical components as grounding points. Stay clear of moving parts. To avoid reverse polarity connections, make sure that you correctly identify the positive (+) and negative (-) terminals on both the disabled and booster vehicles before connecting the cables.

**Note:** In the illustration, the bottom vehicle represents the booster vehicle.

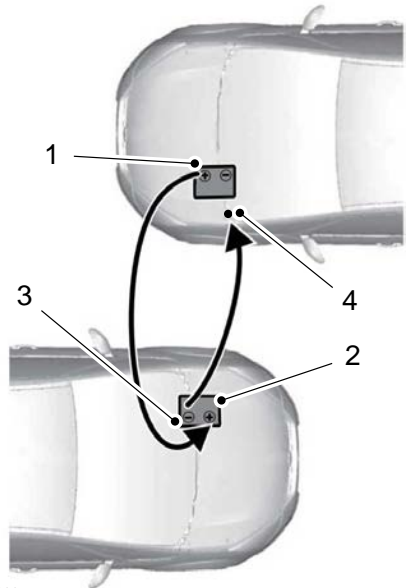

E142664

# Roadside Emergencies

1. Connect the positive (+) jumper cable to the positive (+) terminal of the discharged battery.
2. Connect the other end of the positive (+) cable to the positive (+) terminal of the assisting battery.
3. Connect the negative (-) cable to the negative (-) terminal of the assisting battery.
4. Make the final connection of the negative (-) cable to an exposed metal part of the stalled vehicle's engine, or connect the negative (-) cable to a ground connection point if available.

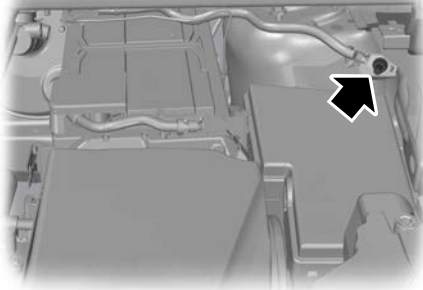

E130431



**WARNING:** Do not connect the end of the second cable to the negative (-) terminal of the battery to be jumped. A spark may cause an explosion of the gases that surround the battery.

## Jump Starting

1. Start the engine of the booster vehicle and rev the engine moderately, or press the accelerator gently to keep your engine speed between 2000 and 3000 rpms, as shown in your tachometer.
2. Start the engine of the disabled vehicle.
3. After starting the disabled vehicle, run both vehicle engines for an additional three minutes before disconnecting the jumper cables.

## Removing the Jumper Cables

Remove the jumper cables in the reverse order that they were connected.

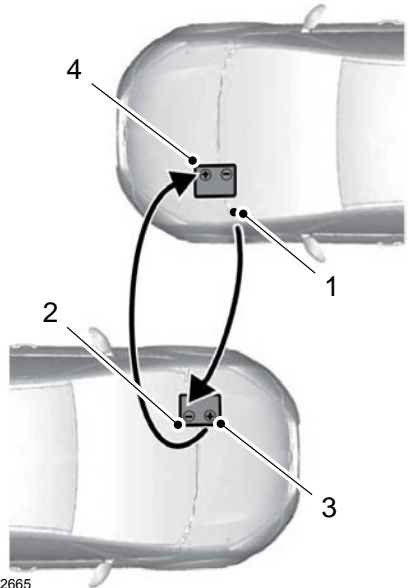

E142665

# Roadside Emergencies

1. Remove the jumper cable from the ground metal surface or connecting point, if available.
2. Remove the jumper cable on the negative (-) terminal of the booster vehicle's battery.
3. Remove the jumper cable from the positive (+) terminal of the booster vehicle's battery.
4. Remove the jumper cable from the positive (+) terminal of the disabled vehicle's battery.

After starting your vehicle and removing the jumper cables, allow it to idle for several minutes so the battery can recharge.

## TOWING POINTS

### Front Towing Point



**WARNING:** Make sure that the towing eye is fully tightened. Failure to follow this instruction could result in personal injury.



**WARNING:** You must switch the ignition on when your vehicle is being towed.

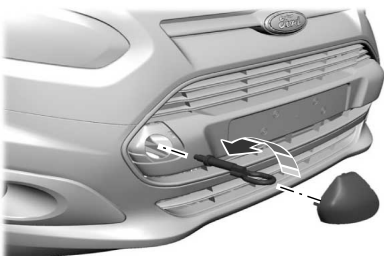

E165018

1. Carefully remove the cover.

2. Install the towing eye.

**Note:** It has a left-hand thread. Turn it counterclockwise to install it.

### Rear Towing Point



**WARNING:** Make sure that the towing eye is fully tightened. Failure to follow this instruction could result in personal injury.



E165019

1. Carefully remove the cover.
2. Install the towing eye.

**Note:** It has a left-hand thread. Turn it counterclockwise to install it.

### Towing Eye Location

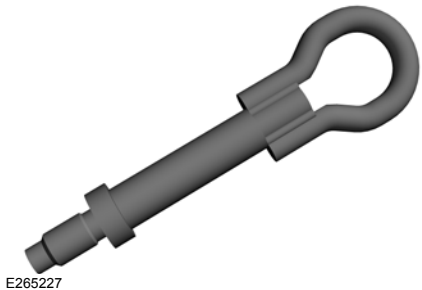

E265227

## Roadside Emergencies

---

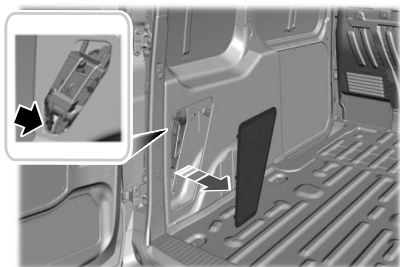

E165020

The towing eye is in the luggage compartment on the left-hand side.

**Note:** *You must carry the towing eye in your vehicle at all times.*

# Fuses

## FUSE BOX LOCATIONS

### Engine Compartment Fuse Box



E272439

The fuse box is in the engine compartment.

### Passenger Compartment Fuse Box

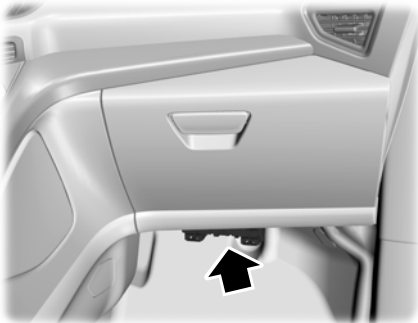

E159113

The fuse box is below the glove box.

### Trailer Tow Module

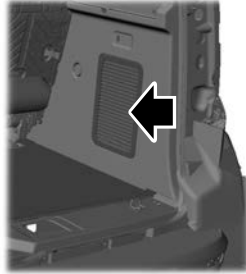

E272461

The fuse box is in the luggage compartment on the right-hand side.

# Fuses

## FUSE SPECIFICATION CHART

### Engine Compartment Fuse Box

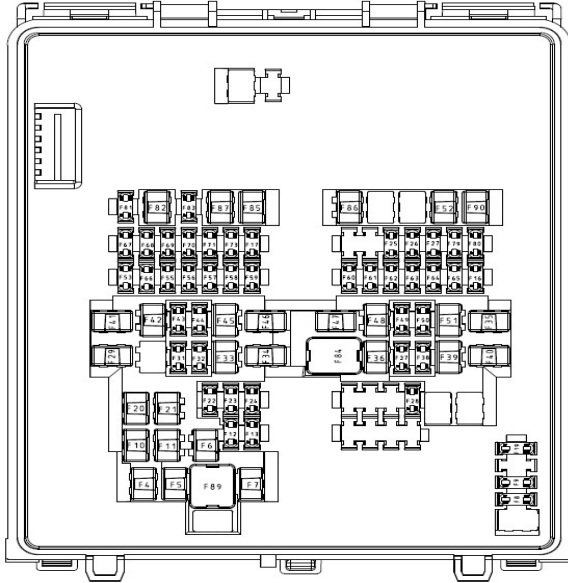

E272453

Fuse Location	Fuse Rating	Protected Component
4	20 A	Cooling fan.
	25 A	Water-in-fuel sensor - diesel.
6	15 A	Windshield wipers.
7	15 A	Windshield wipers.
8	15 A	Rear window washer pump.
9	10 A	Rear cargo door unlock. Liftgate unlock.
10	20 A	Rear floor console auxiliary power point.
11	20 A	Floor console auxiliary power point.

# Fuses

<b>Fuse Location</b>	<b>Fuse Rating</b>	<b>Protected Component</b>
12	5 A	Rain sensor.
13	20 A	Rear window wiper.
16	20 A	Sun shade.
17	15 A	Steering column lock.
19	10 A	Left-hand door unlock.
20	20 A	Auxiliary power point.
21	20 A	Rear auxiliary power points.
22	5 A	USB port.
25	20 A	Dosing control unit - diesel.
26	20 A	Dosing control unit - diesel.
27	15 A	Dosing control unit - diesel.
28	15 A	Transmission control module - diesel.
29	50 A	Glow plugs - diesel.
31	20 A	Right-hand low beam.
32	10 A	Stoplamp switch.
33	30 A	Driver power seat.
34	40 A	Direct current/alternating current inverter.
35	50 A	Glow plugs - diesel.
37	10 A	Modified vehicle connection.
38	10 A	Data link connector.
39	20 A	Fuel-operated parking heater.
40	40 A	Rear blower motor.
41	60 A	Anti-lock brake system. Electronic stability control.
42	40 A	Modified vehicle connection.
43	15 A	Status lamp - taxi.
44	5 A	Headlamps.

## Fuses

Fuse Location	Fuse Rating	Protected Component
45	30 A	Right-hand rear door module.
46	40 A	Body control module.
47	40 A	Trailer tow module.
48	20 A	Heated seats.
49	20 A	Left-hand low beam.
50	5 A	Sun shade.
51	30 A	Anti-lock brake system. Electronic stability control.
52	40 A	Right-hand heated windshield element.
53	10 A	Air conditioning clutch.
55	5 A	Transmission control module.
56	5 A	Anti-lock brake system. Electronic stability control.
57	10 A	Modified vehicle connection.
58	10 A	Powertrain control module.
60	20 A	Modified vehicle connection.
61	15 A	Blind spot information system. Front parking aid camera. Rear view camera.
62	20 A	Body control module.
63	10 A	Modified vehicle connection.
64	5 A	Headlamp leveling.
65	5 A	Electronic power assist steering.
66	5 A	Dosing control unit - diesel. Glow plugs - diesel. Powertrain control module - diesel.
67	20 A	Powertrain control module.
68	20 A	Powertrain control module.
69	15 A	Powertrain control module.

# Fuses

Fuse Location	Fuse Rating	Protected Component
70	20 A	Powertrain control module.
73	5 A	Mass air flow and intake air temperature sensor.
79	10 A	Heated exterior mirrors.
80	5 A	Modified vehicle connection.
81	20 A	Horn.
82	40 A	Left-hand heated windshield element.
83	5 A	Windshield heated washer jets.
84	60 A	Cooling fan.
85	30 A	Fuel pump.
86	20 A	Starter motor.
87	60 A	Glow plug module - diesel.
89	40 A	Blower motor.
90	25 A	Heated rear window.

## Passenger Compartment Fuse Box

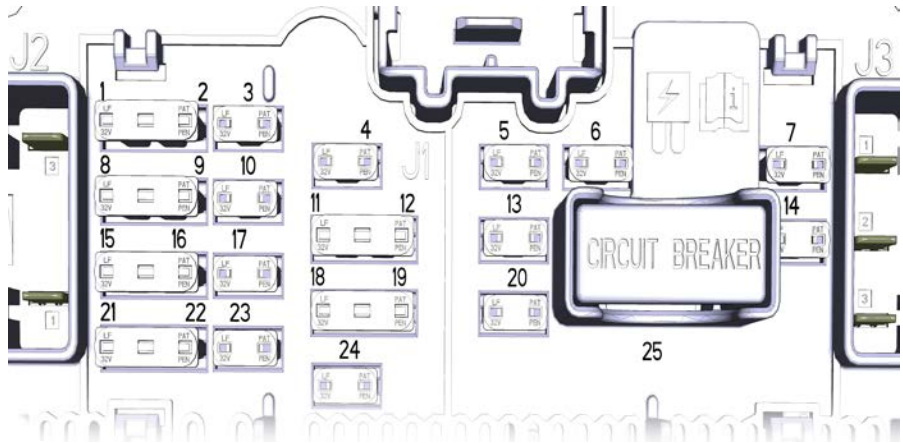

E249945

# Fuses

<b>Fuse Location</b>	<b>Fuse Rating</b>	<b>Protected Component</b>
1	5 A	Restraints control module.
2	5 A	In-vehicle temperature and humidity sensor. Rear blower motor.
3	10 A	Parking assist control module.
4	10 A	Ignition switch. Push button ignition switch.
5	20 A	Central locking system.
6	10 A	Direct current inverter. Driver door lock. Power exterior mirror switch.
7	30 A	Driver door control.
9	5 A	Auto-dimming interior mirror. Front parking aid camera. Passenger airbag deactivation indicator.
10	10 A	Restraints control module.
11	5 A	Telematics control unit module.
12	5 A	Anti-theft alarm.
13	15 A	Unlock.
14	30 A	Passenger door control.
15	10 A	Battery energy control module.
17	15 A	Voice control. Information and entertainment display. Compact disc player.
18	7.5 A	Wireless accessory charging module.
19	7.5 A	Battery back-up sounder.
20	10 A	Security horn.
21	7.5 A	Climate control.
22	7.5 A	Data link connector.

# Fuses

Fuse Location	Fuse Rating	Protected Component
		Instrument cluster.
23	20 A	Audio unit.
25	30 A	Power windows.

## Trailer Tow Module Fuse Box

Fuse Location	Fuse Rating	Protected Component
1	15 A	Power supply.
2	15 A	Ignition system.

## CHANGING A FUSE

### General Information

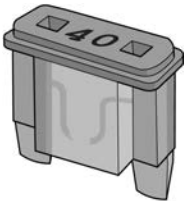

E217331

If electrical components in the vehicle are not working, a fuse may have blown. Blown fuses are identified by a broken wire within the fuse.

### Passenger Compartment Fuse Box



**WARNING:** Always replace a fuse with one that has the specified amperage rating. Using a fuse with a higher amperage rating can cause severe wire damage and could start a fire.

1. Fold back the carpet under the glove compartment.

2. Carefully remove the cover.

### Trailer Tow Module Fuse Box



**WARNING:** Always replace a fuse with one that has the specified amperage rating. Using a fuse with a higher amperage rating can cause severe wire damage and could start a fire.

1. Carefully remove the cover.
2. Fold back the carpet.

### Fuse Types

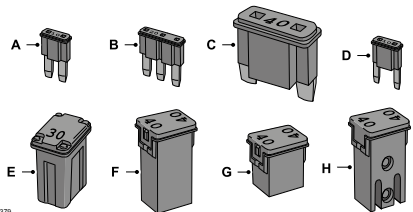

E267379

- A Micro 2.
- B Micro 3.
- C Maxi.

# Fuses

---

- D Mini.
- E M Case.
- F J Case.
- G J Case Low Profile.
- H Slotted M Case.

# Maintenance

## GENERAL INFORMATION



**WARNING:** Do not work on a hot engine.



**WARNING:** Switch the ignition off and apply the parking brake.



**WARNING:** Do not touch the electronic ignition system parts after you have switched the ignition on or when the engine is running. The system operates at high voltage. Failure to adhere to this warning could result in serious personal injury or death.



**WARNING:** Keep your hands and clothing clear of the engine cooling fan.

Under certain conditions, the engine cooling fan may continue to run for several minutes after you switch your vehicle off. See **Engine Cooling Fan** (page 246).

Make sure that you fit filler caps securely after carrying out maintenance checks.

We recommend that you carry out the following checks.

### Check Daily

- Exterior lamps.
- Interior lamps.
- Warning lamps and indicators.

### Check When Refueling

- Washer fluid level. See **Washer Fluid Check** (page 248).
- Tire pressures. See **Tire Care** (page 264).
- Tire condition. See **Wheels and Tires** (page 260).

### Check Monthly

- Engine oil level. See **Engine Oil Check** (page 245).
- Engine coolant level. See **Engine Coolant Check** (page 246).
- Brake fluid level. See **Brake Fluid Check** (page 248).
- Pipes, hoses and reservoirs for leaks.
- Air conditioning operation.
- Parking brake operation.
- Horn operation.
- Tightness of lug nuts. See **Lug Nuts** (page 281).

## OPENING AND CLOSING THE HOOD

### Opening the Hood

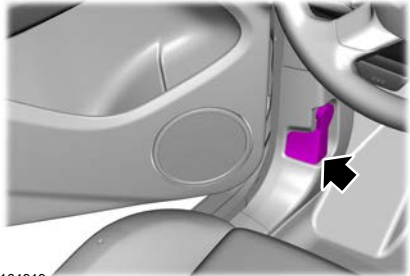

E164919

1. Open the left-hand front door.
2. Pull the hood release handle.

# Maintenance

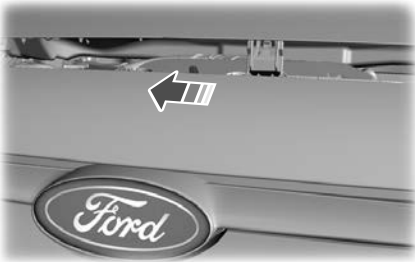

E164920

3. Move the catch to the left.



E87786

4. Open the hood and support it with the support rod.

## Closing the Hood

1. Remove the support rod from the catch and secure correctly.
2. Lower the hood and allow it to drop under its own weight for the last 8 inches to 12 inches (20 centimeters to 30 centimeters).

**Note:** *Make sure the hood is fully closed.*

# Maintenance

## UNDER HOOD OVERVIEW - 1.0L ECOBOOST™

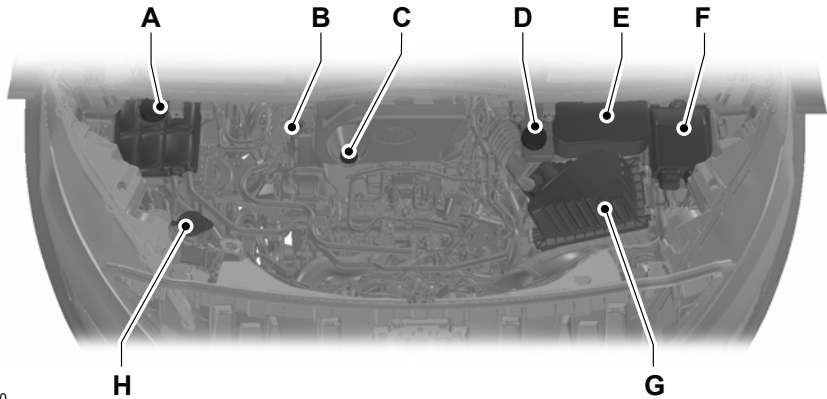

E272650

- A Engine coolant reservoir.\* See **Engine Coolant Check** (page 246).
- B Engine oil dipstick.\* See **Engine Oil Dipstick** (page 245).
- C Engine oil filler cap.\* See **Engine Oil Dipstick** (page 245).
- D Brake and clutch fluid reservoir.\* See **Brake Fluid Check** (page 248). See **Clutch Fluid Check** (page 248).
- E Battery. See **Changing the 12V Battery** (page 249).
- F Engine compartment fuse box. See **Fuses** (page 232).
- G Air cleaner. No maintenance necessary.
- H Windshield and rear window washer fluid reservoir. See **Washer Fluid Check** (page 248).

\* The filler caps and the engine oil dipstick are colored for easy identification.

# Maintenance

## UNDER HOOD OVERVIEW - 1.5L DURATORQ-TDCI DIESEL, LHD

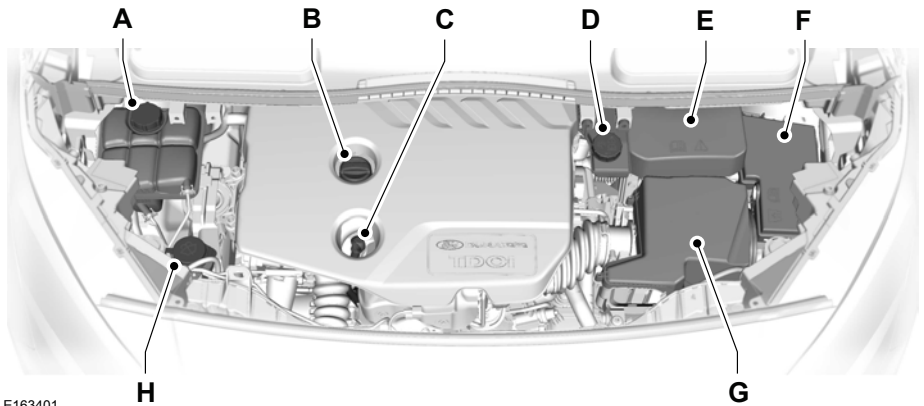

E163401

- A Engine coolant reservoir\*: See **Engine Coolant Check** (page 246).
- B Engine oil filler cap\*: See **Engine Oil Dipstick** (page 245).
- C Engine oil dipstick\*: See **Engine Oil Dipstick** (page 245).
- D Brake and clutch fluid reservoir\*: See **Brake Fluid Check** (page 248).
- E Battery: See **Changing the 12V Battery** (page 249).
- F Engine compartment fuse box: See **Fuses** (page 232).
- G Air cleaner: No maintenance necessary.
- H Windshield and rear window washer fluid reservoir: See **Washer Fluid Check** (page 248).

\* The filler caps and the engine oil dipstick are colored for easy identification.

# Maintenance

## UNDER HOOD OVERVIEW - 1.5L DURATORQ-TDCI DIESEL, RHD

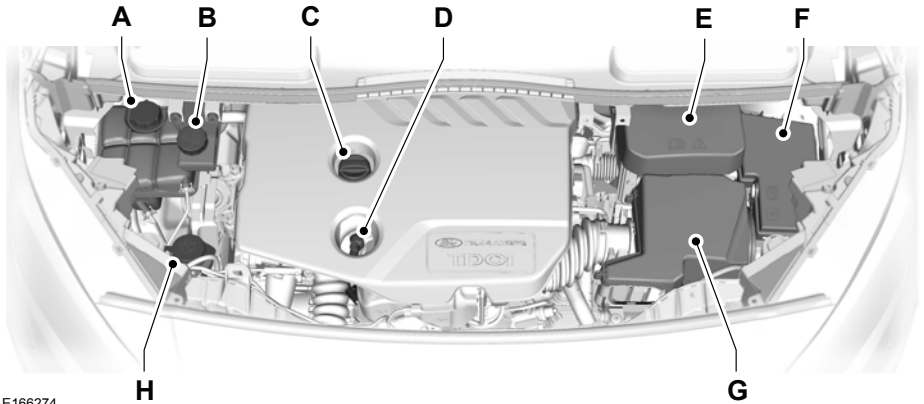

E166274

- A Engine coolant reservoir\*: See **Engine Coolant Check** (page 246).
- B Brake and clutch fluid reservoir\*: See **Brake Fluid Check** (page 248).
- C Engine oil filler cap\*: See **Engine Oil Dipstick** (page 245).
- D Engine oil dipstick\*: See **Engine Oil Dipstick** (page 245).
- E Battery: See **Changing the 12V Battery** (page 249).
- F Engine compartment fuse box: See **Fuses** (page 232).
- G Air cleaner: No maintenance necessary.
- H Windshield and rear window washer fluid reservoir: See **Washer Fluid Check** (page 248).

\* The filler caps and the engine oil dipstick are colored for easy identification.

# Maintenance

## ENGINE OIL DIPSTICK - 1.0L ECOBOOST™

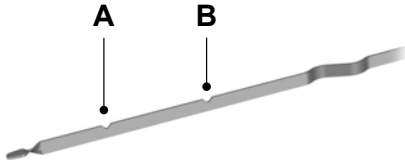

E141337

- A Minimum.
- B Maximum.

## ENGINE OIL DIPSTICK - 1.5L DURATORQ-TDCI DIESEL

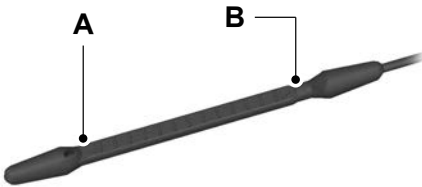

E140423

- A Minimum.
- B Maximum.

## ENGINE OIL CHECK

1. Make sure that your vehicle is on level ground.
2. Check the oil level before starting the engine, or switch the engine off and wait 10 minutes for the oil to drain into the oil pan.

3. Remove the dipstick and wipe it with a clean, lint-free cloth. Reinstall the dipstick and remove it again to check the oil level.

If the oil level is at the minimum mark, immediately add oil.

**Note:** Make sure that the oil level is between the minimum and the maximum marks.

**Note:** The oil consumption of new engines reaches its normal level after approximately 5,000 km (3,000 mi).

## Adding Engine Oil

 **WARNING:** Do not add engine oil when the engine is hot. Failure to follow this instruction could result in personal injury.

 **WARNING:** Do not remove the filler cap when the engine is running.

Do not use supplemental engine oil additives because they are unnecessary and could lead to engine damage that may not be covered by the vehicle Warranty.

1. Clean the area surrounding the engine oil filler cap before you remove it.
2. Remove the engine oil filler cap.
3. Add engine oil that meets our specifications. See **Capacities and Specifications** (page 282).
4. Replace the engine oil filler cap. Turn it clockwise until you feel a strong resistance.

**Note:** Do not add oil further than the maximum mark. Oil levels above the maximum mark may cause engine damage.

**Note:** Immediately soak up any oil spillage with an absorbent cloth.

# Maintenance

## OIL CHANGE INDICATOR RESET

Only reset the system after changing the engine oil and oil filter.

### Resetting the Oil Life Monitoring System

1. Switch the ignition on. Do not start the engine.
2. Fully press the accelerator and brake pedals at the same time.
3. Keep the accelerator and brake pedals fully pressed.
4. After three seconds, a message appears confirming that the reset is in progress.
5. After 25 seconds, a message appears confirming that the reset is complete.
6. Release the accelerator and brake pedals.
7. Switch the ignition off.

## ENGINE COOLING FAN - GASOLINE

 **WARNING:** Keep your hands and clothing clear of the engine cooling fan.

Under certain conditions, the engine cooling fan may continue to run for several minutes after you switch your vehicle off.

## ENGINE COOLING FAN - DIESEL

 **WARNING:** Keep your hands and clothing clear of the engine cooling fan.

Under certain conditions, the engine cooling fan may continue to run for several minutes after you switch your vehicle off. This could happen in low ambient temperatures and independent of the engine coolant temperature, for example short journeys or low coolant temperature. See **Diesel Particulate Filter** (page 154).

## ENGINE COOLANT CHECK

 **WARNING:** Do not dispose of coolant in the household refuse or the public sewage system. Use an authorized waste disposal facility.

 **WARNING:** Do not put coolant in the windshield washer reservoir. If sprayed on the windshield, coolant could make it difficult to see through the windshield.



E170684

# Maintenance

Make sure that the coolant level is between the **MIN** and **MAX** marks on the coolant reservoir at ambient temperature. If the coolant level is at or below the minimum mark, immediately add coolant.

The coolant concentration should be maintained within 48% to 50%, which equates to a freeze point between -34°C (-29°F) and -37°C (-35°F).

**Note:** Coolant expands when it is hot. The level may extend beyond the **MAX** mark.

**Note:** Do not use stop leak pellets, cooling system sealants, or non-specified additives as they can cause damage to the engine cooling or heating systems.

## Adding Coolant



**WARNING:** Do not remove the coolant reservoir cap when the engine is on or the cooling system is hot. Wait 10 minutes for the cooling system to cool down. Cover the coolant reservoir cap with a thick cloth to prevent the possibility of scalding and slowly remove the cap. Failure to follow this instruction could result in personal injury.



**WARNING:** Do not allow the fluid to touch your skin or eyes. If this happens, rinse the affected areas immediately with plenty of water and contact your physician.



**WARNING:** Undiluted coolant is flammable and may ignite if spilled on a hot exhaust.

We do not recommend the use of recycled engine coolant since a Ford-approved recycling process is not yet available.

Do not mix different colors or types of coolant in your vehicle.

**Note:** Add a 50/50 mixture of antifreeze and water or prediluted engine coolant that meets the correct specification.

**Note:** Use fluids which meet the specifications or requirements defined. Use of other fluids may lead to damage which is not covered by the vehicle Warranty. See **Capacities and Specifications** (page 282).

To top up the coolant level do the following:

1. Remove the coolant reservoir cap.
2. Add coolant to the **MAX** mark, do not overfill.
3. Replace the coolant reservoir cap. Turn it clockwise until you feel a strong resistance.

In case of emergency, you can add water without engine coolant in order to reach a vehicle service location.

**Note:** Prolonged use of an incorrect dilution of coolant can cause damage, for example corrosion, overheating or freezing.

## AUTOMATIC TRANSMISSION FLUID CHECK

The automatic transmission does not have a transmission fluid dipstick.

Have an authorized dealer check and change the transmission fluid at the correct service interval. Your transmission does not consume fluid. However, if the transmission slips, shifts slowly or if you notice a sign of leaking fluid, contact an authorized dealer.

Do not use supplemental transmission fluid additives, treatments or cleaning agents. The use of these materials may affect transmission operation and result in damage to internal transmission components.

# Maintenance

## BRAKE FLUID CHECK

**!** **WARNING:** Do not use any fluid other than the recommended brake fluid as this will reduce brake efficiency. Use of incorrect fluid could result in the loss of vehicle control, serious personal injury or death.

**!** **WARNING:** Only use brake fluid from a sealed container. Contamination with dirt, water, petroleum products or other materials may result in brake system damage or failure. Failure to adhere to this warning could result in the loss of vehicle control, serious personal injury or death.

**!** **WARNING:** Do not allow the fluid to touch your skin or eyes. If this happens, rinse the affected areas immediately with plenty of water and contact your physician.

**!** **WARNING:** A fluid level between the **MAX** and **MIN** lines is within the normal operating range and there is no need to add fluid. A fluid level not in the normal operating range could compromise the performance of the system. Have your vehicle checked immediately.



E170684

To avoid fluid contamination, the reservoir cap must remain in place and fully tight, unless you are adding fluid.

Only use fluid that meets Ford specifications.

## CLUTCH FLUID CHECK - MANUAL TRANSMISSION

The clutch and brake systems share the same fluid reservoir. See **Brake Fluid Check** (page 248).

## WASHER FLUID CHECK

When adding fluid, use a mixture of washer fluid and water to help prevent freezing in cold weather and improve the cleaning capability. For information on fluid dilution, refer to the product instructions. We recommend that you only use high quality washer fluid.

**Note:** *The reservoir supplies the front and rear washer systems.*

# Maintenance

## CHANGING THE 12V BATTERY



**WARNING:** For vehicles with Auto-Start-Stop the battery requirement is different. You must replace the battery with one of exactly the same specification.

The battery is in the engine compartment. See **Under Hood Overview** (page 242).



Make sure that you dispose of old batteries in an environmentally friendly way.

Seek advice from your local authority about recycling old batteries.

## CHECKING THE WIPER BLADES



E142463

Run the tip of your fingers over the edge of the blade to check for roughness.

Clean the wiper blades with washer fluid or water applied with a soft sponge or cloth.

## CHANGING THE FRONT WIPER BLADES

1. Switch the ignition off.

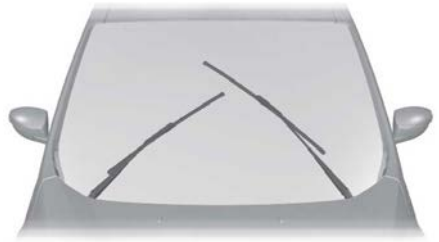

E162532

2. Manually move the wiper arms to the service position. The windshield wipers return to the starting position when you switch the ignition on.

**Note:** Do not hold the wiper blade when moving the wiper arm to the service position.

**Note:** You cannot manually move the wiper arms to the service position when you switch the ignition on.

**Note:** You can use the service position to provide easier access to the wiper blades for freeing them from snow and ice.

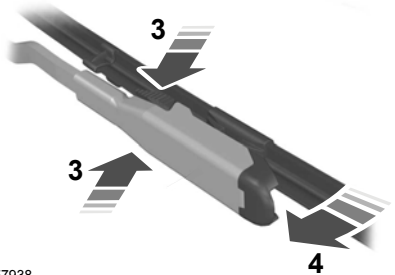

E257938

3. Lift the wiper arm and then press the wiper blade locking buttons together.

**Note:** Do not hold the wiper blade when lifting the wiper arm.

4. Slightly rotate the wiper blade.

5. Remove the wiper blade.

# Maintenance

**Note:** Make sure that the wiper arm does not spring back against the glass when the wiper blade is not attached.

6. To install, reverse the removal procedure.

**Note:** Make sure that the wiper blade locks into place.

## CHANGING THE REAR WIPER BLADES - VEHICLES WITH: MANUAL LIFTGATE

1. Lift the wiper arm.

**Note:** Do not hold the wiper blade when lifting the wiper arm.

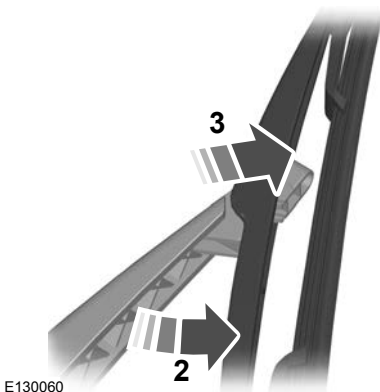

2. Slightly rotate the wiper blade.
3. Remove the wiper blade.

**Note:** Make sure that the wiper arm does not spring back against the glass when the wiper blade is not attached.

4. To install, reverse the removal procedure.

**Note:** Make sure that the wiper blade locks into place.

## CHANGING THE REAR WIPER BLADES - VEHICLES WITH: REAR CARGO DOORS

1. Lift the wiper arm.

**Note:** Do not hold the wiper blade to lift the wiper arm.

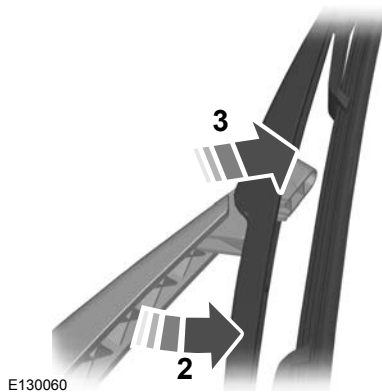

2. Slightly rotate the wiper blade.
3. Remove the wiper blade.

**Note:** Make sure that the wiper arm does not spring back against the glass when the wiper blade is not attached.

4. To install, reverse the removal procedure.

**Note:** Make sure that the wiper blade locks into place.

## CHANGING A BULB

 **WARNING:** Switch the lamps and the ignition off. Failure to do so could result in serious personal injury.

# Maintenance



**WARNING:** Bulbs can become hot, let the bulb cool down before removing it. Failure to do so could result in personal injury.

The following instructions describe how to remove the bulbs. Fit replacements in the reverse order unless otherwise stated.

You must fit bulbs of the correct specification. See **Bulb Specification Chart** (page 292).

**Note:** We recommended that you see an authorized dealer to change the headlamp bulbs if your vehicle is fitted with air conditioning. Some bulbs are difficult to access.

## Headlamp

Remove the covers to gain access to the bulbs.

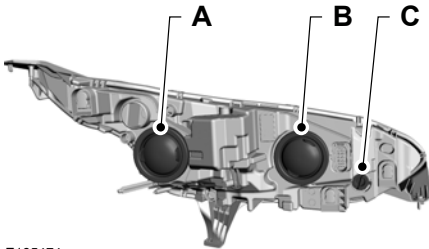

E165474

- A Headlamp low beam and side lamp
- B Headlamp high beam
- C Direction indicator

## Side Lamp

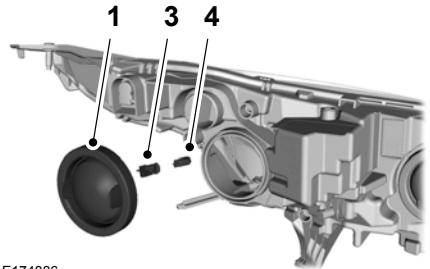

E174886

1. Remove the cover.
2. Remove the low beam bulb to gain access to the side lamp bulb.
3. Remove the bulb holder by pulling it straight out.
4. Remove the bulb from the bulb holder by pulling it straight out.

## Direction Indicator

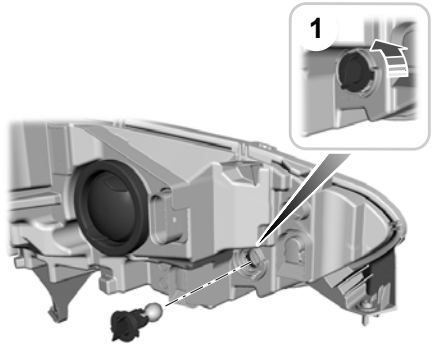

E165475

**Note:** You cannot separate the bulb from the bulb holder.

1. Turn the bulb holder counterclockwise and remove it.

# Maintenance

## Headlamp Low Beam

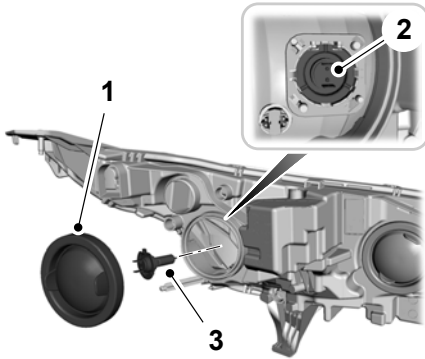

E165477

1. Remove the cover.
  2. Disconnect the electrical connector.
- Note:** Do not touch the glass of the bulb.
3. Remove the bulb by pulling it straight out.

## Headlamp High Beam

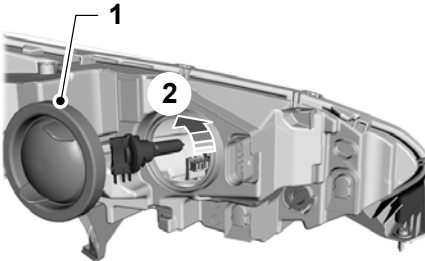

E165476

1. Remove the cover.
- Note:** Do not touch the glass of the bulb.
2. Turn the bulb counterclockwise and remove it.

## Side Direction Indicator

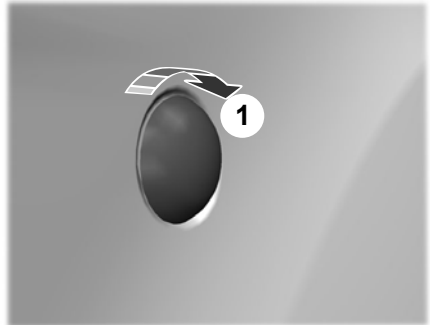

E165495

1. Turn the lamp clockwise and remove it.

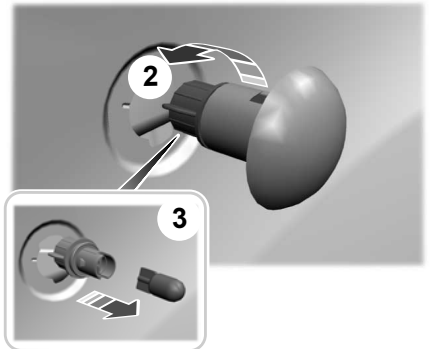

E165496

2. Hold the bulb holder and turn the lamp counterclockwise and remove it.
3. Remove the bulb by pulling it straight out.

# Maintenance

## Front Fog Lamps

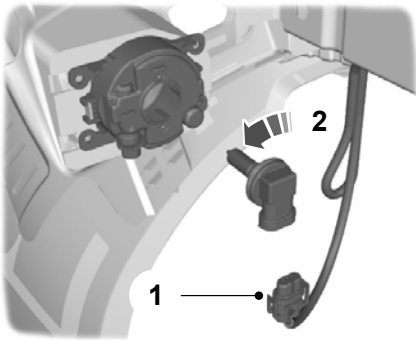

E71062

1. Disconnect the electrical connector.  
**Note:** Do not touch the glass of the bulb.  
**Note:** You cannot separate the bulb from the bulb holder.
2. Turn the bulb holder counterclockwise and remove it.

## Rear Lamps

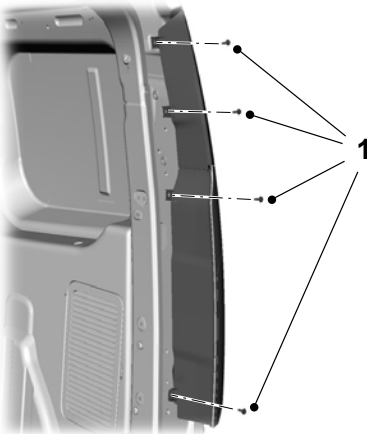

E165484

1. Remove the screws.

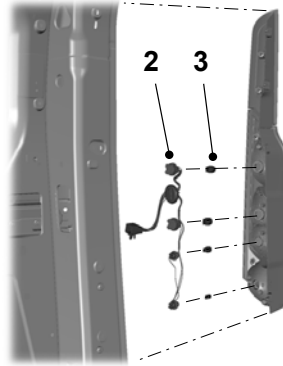

E165485

2. Turn the bulb holders counterclockwise to remove them.
3. Remove the bulbs by pulling them straight out.

## Central High Mounted Brake Lamp

These are not serviceable items, see an authorized dealer if they fail.

## License Plate Lamp

These are not serviceable items, see an authorized dealer if they fail.

## Front Interior Lamp

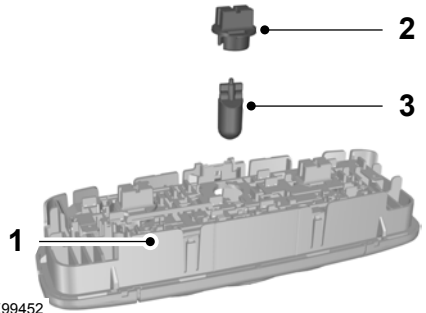

E99452

# Maintenance

1. Carefully remove the lamp.
2. Turn the bulb holder counterclockwise and remove it.

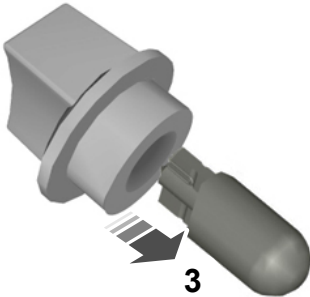

E73939

3. Remove the bulb by pulling it straight out.

## Front Interior LED Lamps (If Equipped)

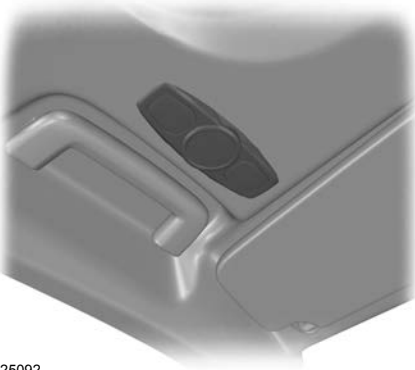

E125092

**Note:** If your vehicle has LED lamps these are not serviceable items, see an authorized dealer if they fail.

## Reading Lamps

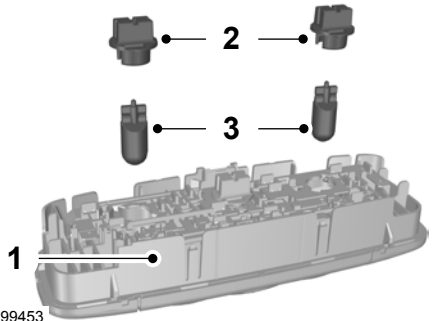

E99453

1. Carefully remove the lamp.
2. Turn the bulb holder counterclockwise and remove it.
3. Remove the bulb by pulling it straight out.

## Cargo Area Lamp (If Equipped)

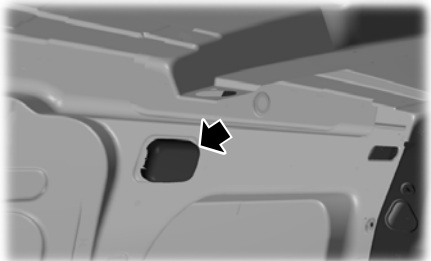

E163429

1. Pry off the lamp cover.

# Maintenance

---

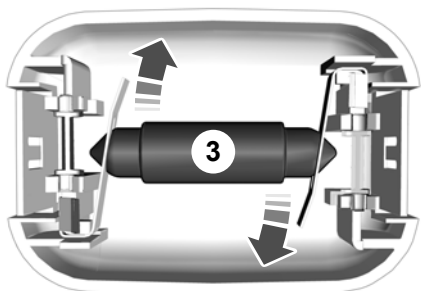
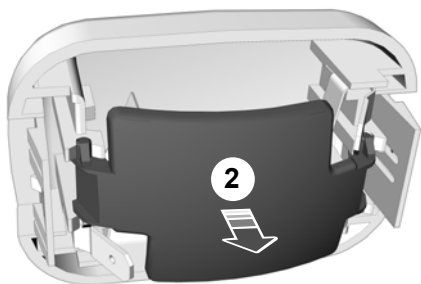

E166153

2. Remove the cover.
3. Remove the bulb.

# Vehicle Care

## CLEANING THE EXTERIOR

Wash your vehicle regularly with cool or lukewarm water and a neutral pH shampoo.

- Never use strong household detergents or soap, for example dish washing or laundry liquid. These products can discolor and spot painted surfaces.
- Never wash your vehicle when it is hot to the touch, or during strong or direct sunlight.
- Dry your vehicle with a chamois or soft terry cloth towel to eliminate water spotting.
- Immediately remove fuel spillages, bird droppings, insect deposits and road tar. These may cause damage to your vehicle's paintwork or trim over time.
- Remove any exterior accessories, for example antennas, before entering a car wash.
- When filling with AdBlue®, remove any residue on painted surfaces immediately.

**Note:** *Suntan lotions and insect repellents can damage painted surfaces. If these substances come in contact with your vehicle, wash the affected area as soon as possible.*

**Note:** *If you use a car wash with a waxing cycle, make sure that you remove the wax from the windshield and the wiper blades.*

**Note:** *Before using a car wash, check that it is suitable for your vehicle.*

**Note:** *Some car washes use water at high pressure. Due to this, water droplets may enter inside your vehicle and could also damage certain parts of your vehicle.*

**Note:** *Remove the antenna before using an automatic car wash.*

**Note:** *Switch the blower motor off to prevent contamination of the cabin air filter.*

We recommend that you wash your vehicle with a sponge and lukewarm water containing a car shampoo.

## Cleaning the Headlamps

**Note:** *Do not scrape the headlamps.*

**Note:** *Do not use abrasives, alcoholic solvents or chemical solvents to clean the headlamps.*

**Note:** *Do not wipe the headlamps when they are dry.*

## Cleaning the Rear Window

**Note:** *Do not scrape the inside of the rear window*

**Note:** *Do not use abrasives, alcoholic solvents or chemical solvents to clean the inside of the rear window.*

Clean the inside of the rear window with a soft, lint-free cloth and non-abrasive cleaner.

## Cleaning the Chrome Trim (If Equipped)

**Note:** *Do not use abrasives or chemical solvents. Use soapy water.*

**Note:** *Do not apply cleaning product to hot surfaces and do not leave cleaning product on chrome surfaces for a period of time exceeding that which is recommended.*

**Note:** *Industrial-strength (heavy-duty) cleaners, or cleaning chemicals, may cause damage over a period of time.*

## Cleaning Stripes or Graphics (If Equipped)

Hand washing your vehicle is preferred however, pressure washing may be used under the following conditions:

- Do not use water pressure higher than 14,000 kPa (2,000 psi).
- Do not use water hotter than 82°C (179°F).

# Vehicle Care

- Use a spray with a 40° wide spray angle pattern.
- Keep the nozzle at a 305 mm (12 in) distance and 90° angle to your vehicle's surface.

**Note:** Holding the pressure washer nozzle at an angle to the vehicle's surface may damage graphics and cause the edges to peel away from the vehicle's surface.

## Body Paintwork Preservation

Frequently remove particles such as bird droppings, tree sap, insect deposits, tar spots, road salt and industrial fallout to avoid paint surface damage.

Frequently wash the underbody of your vehicle if salt is applied on the road.

We recommend that you wax the paintwork once or twice a year.

**Note:** Do not apply polish in strong sunlight as this dries the polish too quickly.

**Note:** Do not allow polish to come in contact with plastic surfaces as it could be difficult to remove.

**Note:** Do not apply polish to the windshield or rear window. A contaminated windshield or contaminated wiper blades may lead to increased wiper noise, reduced wipe quality or reduced rain sensor performance.

## CLEANING THE INTERIOR

**Note:** Do not allow air fresheners and hand sanitizers to spill on interior surfaces. If a spill occurs, wipe off immediately. Damage may not be covered by the vehicle Warranty.

**Note:** Do not use household cleaning products or glass cleaners, which can stain and discolor the fabric and affect the flame retardant abilities of the seat materials.

**Note:** We recommend distilled water when cleaning.

## Fabric, Carpets, Cloth Seats, Headliners and Floor Mats

**Note:** Avoid soaking any surface. Do not use excessive amounts of water to clean the vehicle interior.

**Note:** To avoid spots or discoloration, clean the entire surface.

To clean:

- Remove dust and loose dirt with a vacuum cleaner or brush.
- Wipe the surface with a soft, damp cloth and a mild soap and water solution. Dry the area with a clean, soft cloth.
- If a ring forms on the fabric after spot cleaning, clean the entire area immediately, but do not soak or the ring will set.

## Seatbelts

 **WARNING:** Do not use cleaning solvents, bleach or dye on the vehicle's seatbelts, as these actions may weaken the belt webbing.

 **WARNING:** On vehicles equipped with seat-mounted airbags, do not use chemical solvents or strong detergents. Such products could contaminate the side airbag system and affect performance of the side airbag in a crash.

**Note:** Do not use abrasives, or chemical solvents to clean them.

**Note:** Do not allow moisture to penetrate the seatbelt retractor mechanism.

Cleaning may safely be carried out using mild soap and water. Let them dry naturally, away from artificial heat.

# Vehicle Care

---

## Leather Interior (If Equipped)

**Note:** *Follow the same procedure as cleaning leather seats for cleaning leather instrument panels and leather interior trim surfaces.*

For routine cleaning, wipe the surface with a soft, damp cloth and a mild soap and water solution. Dry the area with a clean, soft cloth.

For cleaning and removing stains such as dye transfer, use a leather cleaning product for automotive interiors.

Do not use the following products as these may damage the leather:

- Oil and petroleum or silicone-based leather conditioners.
- Household cleaners.
- Alcohol solutions.
- Solvents or cleaners intended specifically for rubber, vinyl and plastics.

## Suede Micro Fiber Fabric (If Equipped)

**Note:** *Do not steam clean.*

**Note:** *To avoid spots or discoloration, clean the entire surface.*

Do not use the following products:

- Leather care products.
- Household cleaners.
- Alcoholic solutions.
- Spot removers.
- Shoe polish.

To clean:

- Remove dust and loose dirt with a vacuum cleaner.
- Wipe the surface with a soft, damp cloth and a mild soap and water solution. Dry the area with a clean, soft cloth.
- If a ring forms on the fabric after spot cleaning, clean the entire area immediately, but do not soak or the ring will set.

## Instrument Cluster Screens, LCD Screens and Radio Screens

**Note:** *Do not use abrasives, alcoholic solvents or chemical solvents to clean the instrument cluster screens, LCD screens or radio screens. These cleaning products can damage the screens.*

Clean the instrument panel and cluster lens with a clean, damp and soft cloth, then use a clean, dry and soft cloth to dry these areas.

Do not spray any liquid directly onto the screens.

Do not use a microfiber cloth to clean the bezel around the display screens as it could damage the surface.

## Rear Windows

**Note:** *Do not use any abrasive materials to clean the interior of the rear windows.*

**Note:** *Do not install stickers or labels to the interior of the rear windows.*

## Mirrors

Do not clean the housing or glass of any mirror with harsh abrasives, fuel or other petroleum or ammonia-based cleaning products.

# Vehicle Care

---

## Storage Compartments, Cup Holders and Ashtrays

To clean:

- Take out any removable inserts.
- Wipe the surface with a soft, damp cloth and a mild soap and water solution. Dry the area with a clean, soft cloth.

## REPAIRING MINOR PAINT DAMAGE

You should repair paintwork damage caused by stones from the road or minor scratches as soon as possible. A choice of products are available from an authorized dealer.

Remove particles such as bird droppings, tree sap, insect deposits, tar spots, road salt and industrial fallout before repairing paint chips.

Always read and follow the manufacturer's instructions before using the products.

## CLEANING THE WHEELS

**Note:** Do not apply a cleaning chemical to warm or hot wheel rims and covers.

**Note:** Industrial-strength (heavy-duty) cleaners, or cleaning chemicals, in combination with brush agitation to remove brake dust and dirt, could wear away the clear coat finish over a period of time.

**Note:** Do not use hydrofluoric acid-based or high caustic-based wheel cleaners, steel wool, fuels or strong household detergent.

**Note:** If you intend parking your vehicle for an extended period after cleaning the wheels with a wheel cleaner, drive your vehicle for a few minutes before doing so. This will reduce the risk of increased corrosion of the brake discs, brake pads and linings.

**Note:** Some automatic car washes may cause damage to the finish on your wheel rims and covers.

Alloy wheels and wheel covers are coated with a clear coat paint finish. To maintain their condition we recommend that you:

- Clean them weekly with the recommended wheel and tire cleaner.
- Use a sponge to remove heavy deposits of dirt and brake dust accumulation.
- Rinse them thoroughly with a pressurized stream of water when you have completed the cleaning process.

We recommend that you use Ford service wheel cleaner. Make sure that you read and follow the manufacturer's instructions.

Using other non-recommended cleaning products can result in severe and permanent cosmetic damage.

# Wheels and Tires

## GENERAL INFORMATION

The recommended tire inflation pressures are on the tire information label on the driver side B-pillar.

Check and set the tire pressure at the ambient temperature in which you are intending to drive your vehicle and when the tires are cold. See **Tire Pressures** (page 276).

**Note:** Check your tire pressures regularly to optimize fuel economy.

Only use approved wheel and tire sizes. Using other sizes could damage your vehicle and could make the National Type Approval invalid.

Installation of any tires that are not the original equipment tire size can cause the speedometer to display incorrect vehicle speed.

## TIRE SEALANT AND INFLATOR KIT



**WARNING:** Do not use the inflator kit on run flat tires. This could cause loss of vehicle control.



**WARNING:** Depending on the type and extent of tire damage, some tires can only be partially sealed or not sealed at all. Loss of tire pressure can affect vehicle handling, leading to loss of vehicle control.



**WARNING:** Do not use the kit on a previously damaged tire, for example when it has been driven under inflated. This could cause loss of vehicle control, personal injury or death.

If your vehicle does not have a spare wheel it has a tire sealant and inflator kit. The kit is in the left-hand side of the luggage compartment. Only use the kit supplied with your vehicle.

**Note:** The kit can only temporarily repair one tire puncture with a maximum puncture size of up to 6 mm (0.24 in).

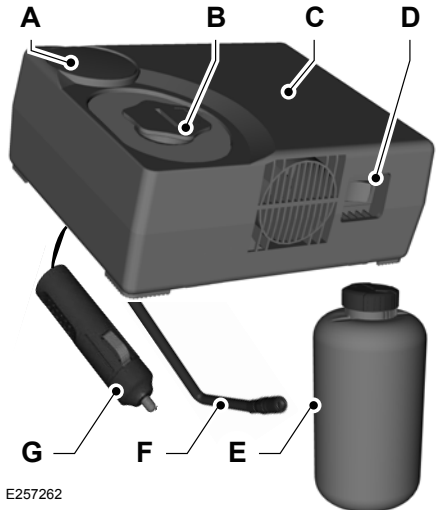

E257262

- A Pressure Gauge.
- B Sealant bottle access cap.
- C Warning label.
- D Power switch.
- E Sealant bottle.
- F Tire inflation pipe.
- G 12 volt DC power point connector.

**Note:** Make sure you regularly check the expiry date on the sealant bottle.

# Wheels and Tires



If the low tire pressure warning lamp illuminates do the following:

1. Gradually reduce the vehicle speed and stop your vehicle as soon as it is safe to do so.
2. Apply the parking brake and switch the ignition off.
3. Check for a punctured tire.

**Note:** Do not remove objects, for example nails or screws from a punctured tire.

## Using the Tire Sealant and Inflator Kit



**WARNING:** Check the sidewall of the tire prior to inflation. If there are any cracks, bumps or similar damage, do not attempt to inflate the tire. This could cause personal injury.



**WARNING:** Watch the sidewall of the tire when inflating. If any cracks, bumps or similar damage appears, switch the compressor off and let the air out by means of the pressure relief valve. Do not continue driving with this tire. This could cause loss of vehicle control.



**WARNING:** Do not stand directly beside the tire while the compressor is operating. This could cause personal injury if the tire bursts.



**WARNING:** Do not leave the kit unattended when it is in use. Failure to follow this instruction could result in personal injury or death.



**WARNING:** Do not keep the compressor operating for more than 10 minutes. This could cause the compressor to malfunction causing serious personal injury.

To temporarily repair a punctured tire, do the following:



E257263

1. Release the tire inflation pipe and the 12 volt DC power point connector from the underside of the compressor.

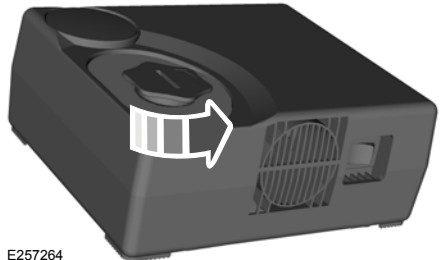

E257264

## Wheels and Tires

- Turn the sealant bottle access cap counterclockwise and remove it.

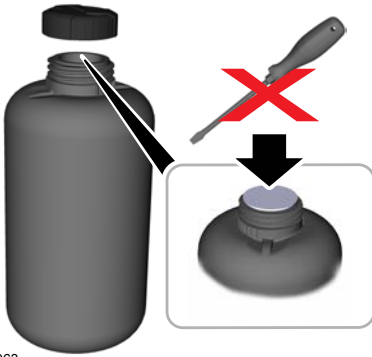

E256963

- Remove the sealant bottle cap. Do not pierce or remove the seal.

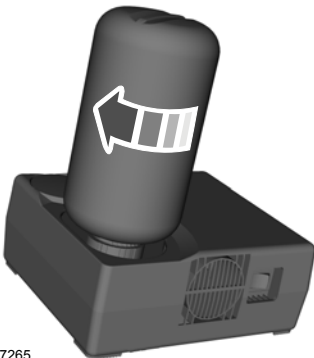

E257265

- Attach the sealant bottle to the compressor. Turn the sealant bottle clockwise until you feel a strong resistance.

**Note:** *Attaching the sealant bottle to the compressor pierces the seal. Do not loosen the bottle as sealant could escape.*

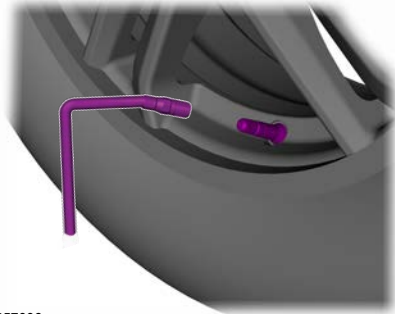

E257006

- Remove the tire valve dust cap and attach the tire inflation pipe.



E257022

- Plug the 12 volt DC power point connector into the 12 volt DC socket. See **Auxiliary Power Points** (page 118).
- Start the engine.

# Wheels and Tires

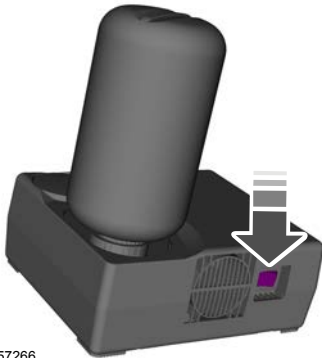

E257266

8. Switch the compressor on.



E257121

9. Inflate the tire to between 2–3 bar (29–44 psi).

**Note:** If the tire pressure does not reach 1.8 bar (26 psi) within 10 minutes, the tire could be damaged beyond a temporary repair. Have your vehicle immediately checked. Do not drive your vehicle.

10. When the tire reaches the recommended tire pressure of between 2–3 bar (29–44 psi), switch the compressor and the ignition off.

11. Disconnect the tire inflation pipe and the 12 volt DC power point connector.

**Note:** Do not remove the sealant bottle from the compressor.

12. Reinstall the tire valve dust cap.
13. Place the warning label on the steering wheel and correctly stow the kit.



E257942

14. Immediately drive your vehicle for 3–10 km (2–6 mi). Do not exceed 80 km/h (50 mph).



E257121

# Wheels and Tires

15. After driving between 3–10 km (2–6 mi), stop your vehicle and recheck the tire pressure. See **Tire Pressures** (page 276).

**Note:** If the tire pressure has dropped to 1.8 bar (26 psi) or below, the tire could be damaged beyond a temporary repair. Have your vehicle immediately checked. Do not drive your vehicle.

**Note:** If the tire pressure has dropped but is still above 1.8 bar (26 psi), use the kit to inflate the tire again.

## After Using the Tire Sealant and Inflator Kit



**WARNING:** If you experience heavy vibrations, unsteady steering behavior or noises while driving, reduce your speed gradually and stop your vehicle as soon as it is safe to do so. Recheck the tire and its pressure. If the tire pressure is less than 1.3 bar (18.9 psi) or if there are any cracks, bumps or similar damage visible, do not continue driving with this tire. This could cause loss of vehicle control.

The kit only provides temporary mobility. Regulations concerning tire repair or replacement after using the kit could differ from country to country. We recommend you consult a tire specialist.

After using the kit:

- Do not drive your vehicle more than 200 km (124 mi) before repairing or replacing the punctured tire.
- Inform all other users of your vehicle that a tire was sealed using the kit. Make them aware of the special driving conditions that must be observed.

- Regularly check the tire pressure until the sealed tire is repaired or replaced by a tire specialist. Before the tire is removed from the rim, you must inform the tire specialist that the tire contains sealant.
- Take the kit to an authorized dealer to have the sealant bottle and the tire inflation pipe replaced.

## TIRE CARE

**Note:** Front tires shown on the left side of the diagram.

### Non-directional tires

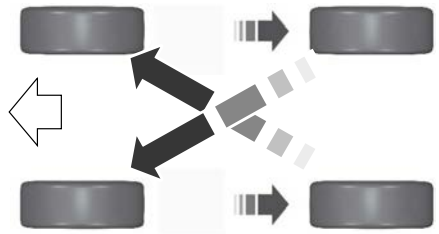

E142547

### Directional tires

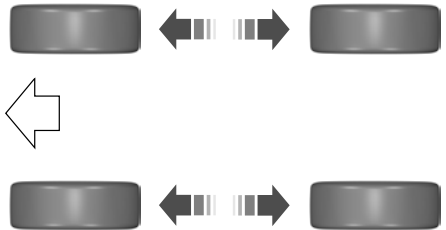

E70415

# Wheels and Tires

To make sure the front and rear tires of your vehicle wear evenly and last longer, we recommend that you swap the tires from front to rear and vice versa at regular intervals between 5,000 km (3,000 mi) and 10,000 km (6,000 mi).



**WARNING:** Do not scrub the sidewalls of the tires when you are parking.

If you have to mount a curb, do so slowly and approach it with the wheels at right-angles to the curb.

Examine the tires regularly for cuts, foreign objects and uneven wear of the tread. Uneven wear could mean that the wheel alignment is outside specification.

Check the tire pressures (including the spare) when cold, every two weeks.

## USING WINTER TIRES



E278852

We recommend that you use winter or all-season tires carrying this symbol when the temperature is 7°C (45°F) or lower, or in snow and ice conditions.

Inflate the winter tires to the same tire pressures as those listed in the tire pressures table. See **Tire Pressures** (page 276).

## USING SNOW CHAINS



**WARNING:** Do not exceed 50 km/h (30 mph). Failure to follow this instruction could result in the loss of control of your vehicle, personal injury or death.



**WARNING:** Do not use snow chains on snow-free roads.



**WARNING:** Only fit snow chains to specified tires.



**WARNING:** If your vehicle is fitted with wheel trims, remove them before fitting snow chains.

Only use snow chains on the front wheels. Do not use self-tensioning snow chains.

Only use snow chains on the following specified tire sizes:

- 205/60R16.
- 215/55R16.

**Note:** Do not use snow chains greater than 10 mm (0.4 in).

Maintain correct tire pressures. See **Tire Pressures** (page 276).

## Vehicles with Stability Control

When stability control is on, your vehicle may exhibit some unusual driving characteristics. To reduce this, switch traction control off. See **Stability Control** (page 167).

**Note:** The anti-lock brake system continues to correctly operate.

# Wheels and Tires

## TIRE PRESSURE MONITORING SYSTEM



**WARNING:** The tire pressure monitoring system is not a substitute for manually checking tire pressures. You should periodically check tire pressures using a pressure gauge. Failure to correctly maintain tire pressures could increase the risk of tire failure, loss of control, vehicle rollover and personal injury.

**Note:** *You should only use tire sealants in roadside emergencies as they may cause damage to the tire pressure monitoring system sensor.*

**Note:** *If the tire pressure monitoring system sensor becomes damaged, it may not function.*



Each tire, including the spare (if provided), should be checked monthly when cold and inflated to the inflation pressure recommended by the vehicle manufacturer on the vehicle placard or tire inflation pressure label. (If your vehicle has tires of a different size than the size indicated on the vehicle placard or tire inflation pressure label, you should determine the proper tire inflation pressure for those tires).

As an added safety feature, your vehicle has been equipped with a Tire Pressure Monitoring System (TPMS) that illuminates a low tire pressure telltale when one or more of your tires is significantly under-inflated. Accordingly, when the low tire pressure telltale illuminates, you should stop and check your tires as soon as possible, and inflate

them to the proper pressure. Driving on a significantly under-inflated tire causes the tire to overheat and can lead to tire failure. Under-inflation also reduces fuel efficiency and tire tread life, and may affect the vehicle's handling and stopping ability.

Please note that the TPMS is not a substitute for proper tire maintenance, and it is the driver's responsibility to maintain correct tire pressure, even if under-inflation has not reached the level to trigger illumination of the TPMS low tire pressure telltale.

Your vehicle has also been equipped with a TPMS malfunction indicator to indicate when the system is not operating properly. The TPMS malfunction indicator is combined with the low tire pressure telltale. When the system detects a malfunction, the telltale will flash for approximately one minute and then remain continuously illuminated. This sequence will continue upon subsequent vehicle start-ups as long as the malfunction exists.

When the malfunction indicator is illuminated, the system may not be able to detect or signal low tire pressure as intended. TPMS malfunctions may occur for a variety of reasons, including the installation of replacement or alternate tires or wheels on the vehicle that prevent the TPMS from functioning properly. Always check the TPMS malfunction telltale after replacing one or more tires or wheels on your vehicle to ensure that the replacement or alternate tires and wheels allow the TPMS to continue to function properly.

# Wheels and Tires

## Changing Tires With a Tire Pressure Monitoring System



E142549

**Note:** Each road tire is equipped with a tire pressure sensor located inside the wheel and tire assembly cavity. The pressure sensor is attached to the valve stem. The pressure sensor is covered by the tire and is not visible unless the tire is removed. Take care when changing the tire to avoid damaging the sensor.

You should always have your tires serviced by an authorized dealer.

Check the tire pressure periodically (at least monthly) using an accurate tire gauge. See **When Inflating Your Tires** in this chapter.

## Changing Wheels With a Tire Pressure Monitoring System

When changing the wheels of your vehicle, the tire pressure monitoring system needs to relearn the tire pressure sensors. To achieve this perform the following:

1. Make sure all tires are inflated to the proper pressure. If not, inflate the tires to the correct pressure.
2. Park your vehicle for at least 20 minutes.

3. Carry out the tire pressure monitoring system reset procedure. See **Tire Pressure Monitoring System Reset Procedure** later in this section.
4. The tire pressure monitoring system automatically re-learns the tire pressure sensors the next time you drive your vehicle for approximately 15 minutes above 40 km/h (25 mph).

## Understanding Your Tire Pressure Monitoring System

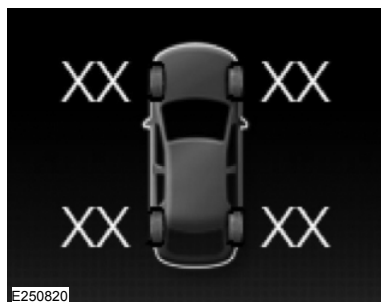

E250820

The tire pressure monitoring system measures pressure in your road tires and sends the tire pressure readings to your vehicle. You can view the tire pressure readings through the information display. See **General Information** (page 80). The low tire pressure warning light will turn on if the tire pressure is significantly low. Once the light is illuminated, your tires are under-inflated and need to be inflated to the manufacturer's recommended tire pressure. Even if the light turns on and a short time later turns off, your tire pressure still needs to be checked.

# Wheels and Tires

---

## **When Your Temporary Spare Tire is Installed**

When one of your road tires needs to be replaced with the temporary spare, the system will continue to identify an issue to remind you that the damaged road wheel and tire assembly needs to be repaired and put back on your vehicle.

To restore the full function of the tire pressure monitoring system, have the damaged road wheel and tire assembly repaired and remounted on your vehicle.

## **When You Believe Your System is Not Operating Properly**

The main function of the tire pressure monitoring system is to warn you when your tires need air. It can also warn you in the event the system is no longer capable of functioning as intended. See the following chart for information concerning your tire pressure monitoring system:

# Wheels and Tires

Low tire pressure warning light	Possible cause	Customer action required
Solid warning light	Tire(s) under-inflated	Make sure tires are at the proper pressure. See <b>Inflating your tires</b> in this chapter. After inflating your tires to the manufacturer's recommended pressure as shown on the Tire Label (located on the edge of driver's door or the B-Pillar), the vehicle must be driven for at least two minutes over 32 km/h (20 mph) before the light turns off.
	Spare tire in use	Repair the damaged road wheel and tire assembly and reinstall it on the vehicle to restore system function. For a description on how the system functions, see <b>When Your Temporary Spare Tire is Installed</b> in this section.
	TPMS malfunction	If the tires are properly inflated and the spare tire is not in use but the light remains on, contact your authorized dealer as soon as possible.
Flashing warning light	Spare tire in use	Repair the damaged road wheel and tire assembly and reinstall it on the vehicle to restore system function. For a description on how the system functions, see <b>When Your Temporary Spare Tire is Installed</b> in this section.
	TPMS malfunction	If the tires are properly inflated and the spare tire is not in use but the light remains on, contact your authorized dealer as soon as possible.

## When Inflating Your Tires



**WARNING:** Do not use the tire pressure displayed in the information display as a tire pressure gauge. Failure to follow this instruction could result in personal injury or death.

When putting air into your tires (such as at a gas station or in your garage), the tire pressure monitoring system may not respond immediately to the air added to your tires.

It may take up to two minutes of driving over 32 km/h (20 mph) for the light to turn off after you have filled your tires to the recommended inflation pressure.

# Wheels and Tires

## How Temperature Affects Your Tire Pressure

The tire pressure monitoring system monitors tire pressure in each pneumatic tire. While driving in a normal manner, a typical passenger tire inflation pressure may increase about 14–28 kPa (2–4 psi) from a cold start situation. If the vehicle is stationary overnight with the outside temperature significantly lower than the daytime temperature, the tire pressure may decrease about 21 kPa (3 psi) for a drop of 30°F (17°C) in ambient temperature. This lower pressure value may be detected by the tire pressure monitoring system as being significantly lower than the recommended inflation pressure and activate the system warning light for low tire pressure. If the low tire pressure warning light is on, visually check each tire to verify that no tire is flat. If one or more tires are flat, repair as necessary. Check the air pressure in the road tires. If any tire is under-inflated, carefully drive the vehicle to the nearest location where air can be added to the tires. Inflate all the tires to the recommended inflation pressure.

## Tire Pressure Monitoring System Reset Procedure

### Overview

You must carry out the system reset procedure after each tire replacement or adjustment of the tire pressures.

To maintain your vehicle load carrying capability, your vehicle may require different tire pressures in the front compared to the rear. In these cases, the system illuminates the warning lamp at different pressures for the front and rear tires.

If the tires are rotated, you need to reset the system in order to relearn the positions of the tire pressure sensors. The system cannot tell which position a tire pressure sensor is in, and assumes you have set the tire pressures correctly.

### Performing the Reset Procedure

1. Switch the ignition on.
2. Navigate to the tire monitor menu in the information display. See **Information Messages** (page 82).
3. Press and hold the OK button until a confirmation message appears. If your vehicle has a tire pressure monitoring system reset button, press and hold the button until a confirmation message appears.

## CHANGING A ROAD WHEEL

### Lug Nuts

You can obtain a replacement locking lug nut key and replacement locking lug nuts from an authorized dealer using the reference number certificate.

### Vehicles with a Spare Wheel

If the spare wheel is exactly the same type and size as the other fitted road wheels, you can replace the existing road wheel with the spare wheel and continue to drive in the normal manner.

If the spare wheel is different to the other road wheels, it will carry a yellow label with the appropriate speed limit.

Refer to the following information before changing the road wheel.

Do not drive through an automatic car wash.

# Wheels and Tires



**WARNING:** Drive the shortest possible distances.



**WARNING:** Do not fit more than one spare wheel on your vehicle at any one time.



**WARNING:** Do not carry out any tire repairs on a spare wheel.



**WARNING:** If you are unsure what type of spare wheel you have do not exceed 80 km/h (50 mph).



**WARNING:** Only fit snow chains to specified tires.



**WARNING:** The ground clearance of your vehicle may be reduced. Take care when parking next to a curb.

**Note:** Your vehicle may exhibit some unusual driving characteristics.

## Vehicle Jack



**WARNING:** The jack supplied with this vehicle is only intended for changing wheels. Do not use the vehicle jack other than when you are changing a wheel in an emergency.



**WARNING:** Check that the vehicle jack is not damaged or deformed and the thread is lubricated and clean.



**WARNING:** Never place anything between the vehicle jack and the ground.



**WARNING:** Never place anything between the vehicle jack and your vehicle.

**Note:** Vehicles with a temporary mobility kit do not have a vehicle jack or a wheel brace.

It is recommended to use a workshop type hydraulic jack for changing between summer and winter tires.

**Note:** Use a jack with a minimum lifting capacity of 1.5 tonnes and a lifting plate with a minimum diameter of approximately 3 inches (76 millimeters).

## Vehicles without a Temporary Mobility Kit

Your vehicle jack and wheel brace are located in the left-hand side of the luggage compartment.

## Jacking and Lifting Points



**WARNING:** Use only the specified jacking points. If you use other positions, you may damage the body, steering, suspension, engine, braking system or the fuel lines.

# Wheels and Tires

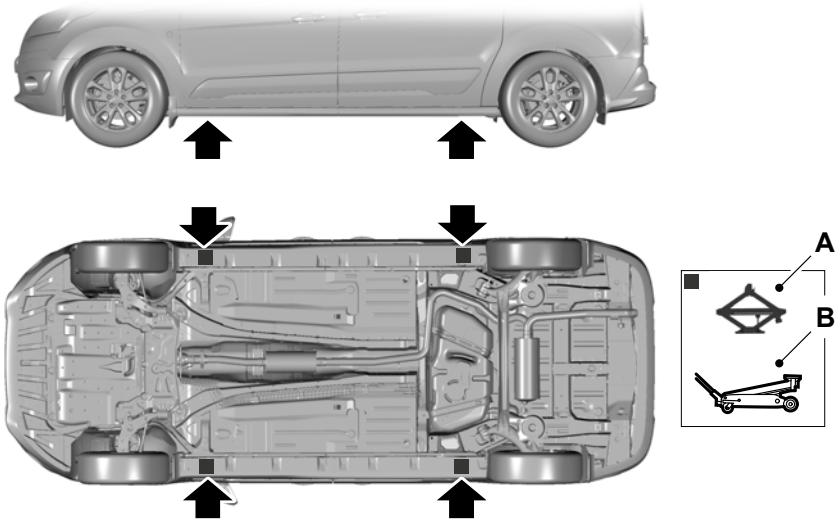

E164258

- A Emergency use only
- B Maintenance

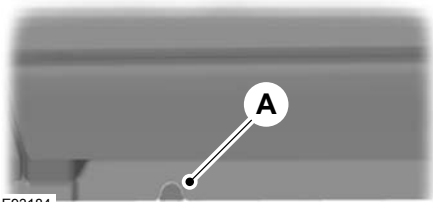

E93184

Indentations in the sills show the location of the jacking points.



E142553

# Wheels and Tires



E93020

**Note:** You can use the wheel brace to raise and lower the jack.

## Lowering the Spare Wheel

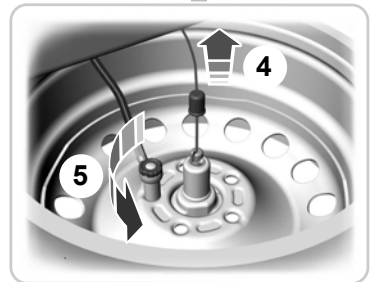
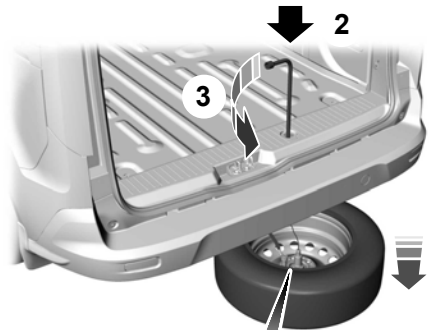

E290868

1. Remove the cap
2. Insert the hexagonal end of the wheel brace into the guide hole.
3. Turn the wheel brace counterclockwise until the spare wheel rests on the ground and there is slack in the cable.
4. Unscrew the cap and slide it back, turn the nipple of the cable through 90 degrees to remove the first cable.
5. Unscrew the nut to remove the second cable.

# Wheels and Tires

## Removing the Wheel Trim

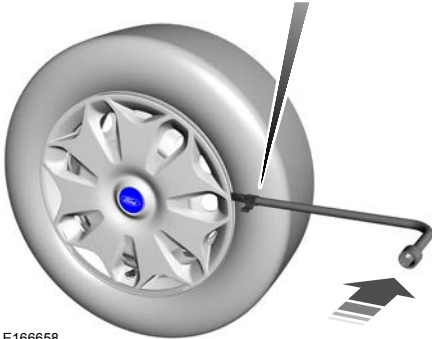
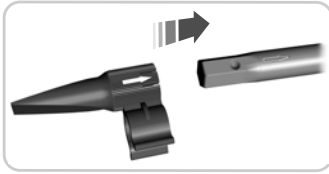

E166658

1. Insert the wheel brace and carefully remove the wheel trim.

**Note:** Make sure that you pull the wheel trim remover at right angles to the trim.

## Removing a Road Wheel

If your vehicle has a manual transmission, select first or reverse gear. If it has an automatic transmission, select park.

**WARNING:** Park your vehicle so that you do not obstruct the flow of traffic or place yourself in any danger and set up a warning triangle.

**WARNING:** Make sure that your vehicle is on firm and level ground with the front wheels pointing straight ahead.

**WARNING:** Switch the ignition off and apply the parking brake.

**WARNING:** Make sure all passengers are out of your vehicle.

**WARNING:** Secure the diagonally opposite wheel with an appropriate block or wheel chock.

**WARNING:** Do not get under a vehicle that is only supported by a vehicle jack.

**WARNING:** Make sure that the vehicle jack is vertical to the jacking point and the base is flat on the ground.

1. Install the locking lug nut key.

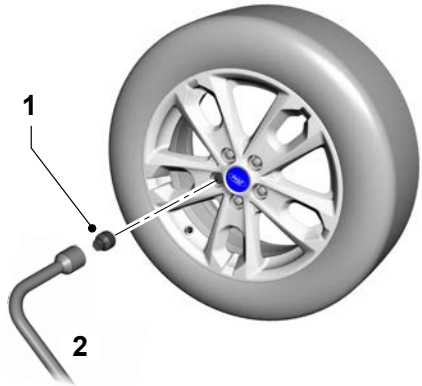

E166675

2. Slacken the lug nuts.
3. Jack up your vehicle until the tire is clear of the ground.
4. Remove the lug nuts and the wheel.

**Note:** Do not lay alloy wheels face down on the ground, this will damage the paint.

# Wheels and Tires

## Installing a Road Wheel



**WARNING:** Make sure that the arrows on directional tires point in the direction of rotation when your vehicle is moving forward. If you have to fit a spare tire with the arrows pointing in the opposite direction have the tire refitted as soon as possible.



**WARNING:** Use only approved wheel and tire sizes. Using other sizes could damage your vehicle and will make the National Type Approval invalid.



**WARNING:** Do not fit run flat tires on vehicles that were not originally fitted with them. See an authorized dealer for more details about compatibility.



**WARNING:** Do not install alloy wheels using lug nuts designed for use with steel wheels.



**WARNING:** Only use the specific lug nuts and wheels supplied with your vehicle. If in doubt, contact an authorized dealer.



**WARNING:** Make sure there is no grease or oil on the threads or the surface between the wheel lugs and nuts. This can cause the lug nuts to loosen while driving.



**WARNING:** The lug nuts of alloy wheels and spoked steel wheels can also be used for the steel spare wheel for a short time (maximum two weeks).



**WARNING:** Make sure the wheel and hub contact surfaces are clean.

**Note:** Make sure that the cones on the lug nuts are against the wheel.

1. Install the wheel.
2. Install the lug nuts finger tight.
3. Install the locking lug nut key.

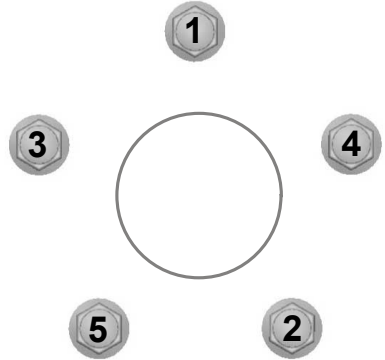

E154985

4. Partially tighten the lug nuts in the sequence shown.
5. Lower your vehicle and remove the jack.
6. Fully tighten the lug nuts in the sequence shown. See **Lug Nuts** (page 281).
7. Install the wheel trim using the ball of your hand.



**WARNING:** Have the lug nuts checked for tightness and the tire pressure checked as soon as possible.

## Stowing the Flat Tire

Do not raise the spare wheel carrier without the wheel attached. Damage can occur to the winch mechanism if lowered without a wheel attached.

# Wheels and Tires

**Note:** Do not lay alloy wheels face down on the ground, this will damage the paint. When stowing the flat tire use a sheet or mat under the wheel to protect the paint.

## TIRE PRESSURES

The recommended tire inflation pressures are on the tire information label on the driver side B-pillar.

Check all tire pressures when they are cold, at least once every two weeks.

**Note:** You may need to remove the spare wheel from the spare wheel well to check the tire pressure.

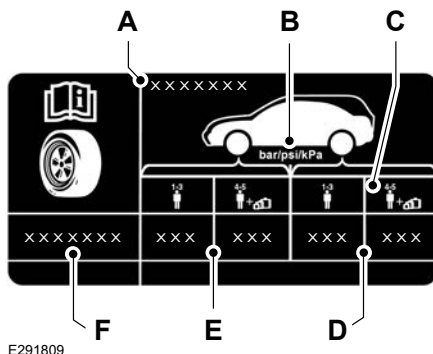

- A Vehicle model.
- B Measure unit.
- C Vehicle load.
- D Rear tire pressure.
- E Front tire pressure.
- F Tire size.

Tire Size	Normal Load		Full Load	
	Front	Rear	Front	Rear
	bar (psi)	bar (psi)	bar (psi)	bar (psi)
205/60 R16 96H XL.	2.4 (35)	2.4 (35)	2.6 (38)	3.4 (49)
215/55 R16 97V XL.				

# Wheels and Tires

## Spare Wheel (If Equipped)



**WARNING:** Do not switch off stability control or select sport mode, when using a temporary spare wheel or after inflating a tire using the temporary mobility kit.

Tire Size	bar (psi)
205/60 R16 96H XL.	3.4 (50)
215/55 R16 97V XL.	

Do not exceed the maximum speed stated on the label attached to the temporary spare wheel.

## TIRE PRESSURES

The recommended tire inflation pressures are on the tire information label on the driver side B-pillar.

Check all tire pressures when they are cold, at least once every two weeks.

**Note:** You may need to remove the spare wheel from the spare wheel well to check the tire pressure.

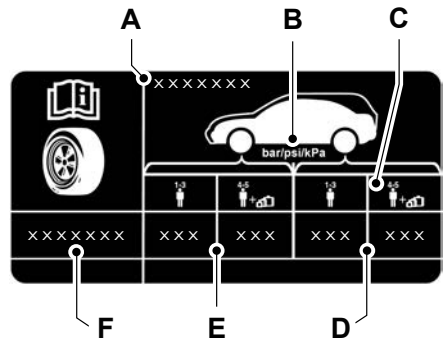

E291809

- A Vehicle model.
- B Measure unit.
- C Vehicle load.
- D Rear tire pressure.
- E Front tire pressure.
- F Tire size.

# Wheels and Tires

Tire Size	Normal Load		Full Load	
	Front	Rear	Front	Rear
	bar (psi)	bar (psi)	bar (psi)	bar (psi)
205/60 R16 96H XL.	2.3 (33)	2.3 (33)	2.6 (38)	3.4 (49)
215/55 R16 97V XL.				

## Spare Wheel (If Equipped)



**WARNING:** Do not switch off stability control or select sport mode, when using a temporary spare wheel or after inflating a tire using the temporary mobility kit.

Tire Size	bar (psi)
205/60 R16 96H XL.	3.4 (50)
215/55 R16 97V XL.	

Do not exceed the maximum speed stated on the label attached to the temporary spare wheel.

## TIRE PRESSURES

The recommended tire inflation pressures are on the tire information label on the driver side B-pillar.

Check all tire pressures when they are cold, at least once every two weeks.

**Note:** You may need to remove the spare wheel from the spare wheel well to check the tire pressure.

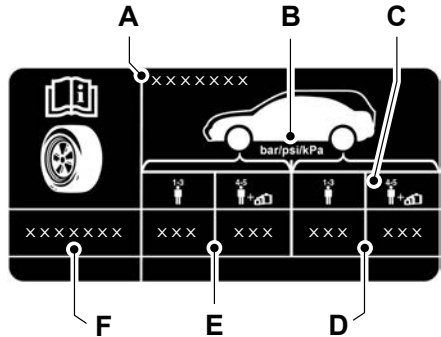

E291809

- A Vehicle model.
- B Measure unit.
- C Vehicle load.

# Wheels and Tires

D Rear tire pressure.

E Front tire pressure.

F Tire size.

## Normal Payload

Tire Size	Normal Load		Full Load	
	Front	Rear	Front	Rear
	bar (psi)	bar (psi)	bar (psi)	bar (psi)
205/60 R16 96H XL.	2.3 (33)	2.2 (32)	2.6 (38)	2.9 (42)
215/55 R16 97V XL.				

## High Payload

Tire Size	Normal Load		Full Load	
	Front	Rear	Front	Rear
	bar (psi)	bar (psi)	bar (psi)	bar (psi)
205/60 R16 96H XL.	2.3 (33)	2.3 (33)	2.6 (38)	3.4 (49)
215/55 R16 97V XL.				

## Spare Wheel (If Equipped)



**WARNING:** Do not switch off stability control or select sport mode, when using a temporary spare wheel or after inflating a tire using the temporary mobility kit.

Tire Size	bar (psi)
205/60 R16 96H XL.	3.4 (50)
215/55 R16 97V XL.	

Do not exceed the maximum speed stated on the label attached to the temporary spare wheel.

# Wheels and Tires

## TIRE PRESSURES

The recommended tire inflation pressures are on the tire information label on the driver side B-pillar.

Check all tire pressures when they are cold, at least once every two weeks.

**Note:** You may need to remove the spare wheel from the spare wheel well to check the tire pressure.

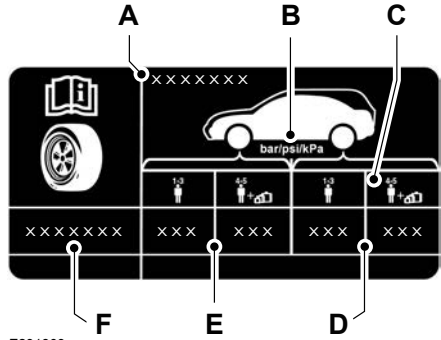

E291809

- A Vehicle model.
- B Measure unit.
- C Vehicle load.
- D Rear tire pressure.
- E Front tire pressure.
- F Tire size.

## Normal Payload

Tire Size	Normal Load		Full Load	
	Front	Rear	Front	Rear
	bar (psi)	bar (psi)	bar (psi)	bar (psi)
205/60 R16 96H XL.	2.3 (33)	2.2 (32)	2.7 (39)	3.2 (46)
215/55 R16 97V XL.				

# Wheels and Tires

## High Payload

Tire Size	Normal Load		Full Load	
	Front	Rear	Front	Rear
	bar (psi)	bar (psi)	bar (psi)	bar (psi)
205/60 R16 96H XL.	2.3 (33)	2.2 (32)	2.5 (36)	3.4 (49)
215/55 R16 97V XL.				

## Spare Wheel (If Equipped)

 **WARNING:** Do not switch off stability control or select sport mode, when using a temporary spare wheel or after inflating a tire using the temporary mobility kit.

Tire Size	bar (psi)
205/60 R16 96H XL.	3.4 (50)
215/55 R16 97V XL.	

Do not exceed the maximum speed stated on the label attached to the temporary spare wheel.

## LUG NUTS

### Lug Nut Torque

Nm ( lb.ft)
204 (150)

### Locking Lug Nuts

You can obtain a replacement locking lug nut key and replacement locking lug nuts from an authorized dealer using the reference number certificate.

# Capacities and Specifications

## VEHICLE DIMENSIONS - LONG WHEELBASE COM KOMBI

### Vehicle Dimensions

<b>Dimension Description</b>	<b>mm (in)</b>
Maximum length.	4,825 (190.0)
Overall width including exterior mirrors.	2,137 (84.1)
Overall height - EC curb weight.	1,820 (71.7)
Wheelbase.	3,062 (120.6)
Front track.	1,568 (61.7)
Rear track.	1,582 (62.3)

## VEHICLE DIMENSIONS - LONG WHEELBASE DOUBLE CAB IN VAN, TRANSIT

### Vehicle Dimensions

<b>Dimension Description</b>	<b>mm (in)</b>
Maximum length.	4,825 (190.0)
Overall width including exterior mirrors.	2,137 (84.1)
Overall height - EC curb weight.	1,862 (73.3)
Wheelbase.	3,062 (120.6)
Front track.	1,568 (61.7)
Rear track.	1,582 (62.3)

# Capacities and Specifications

---

## VEHICLE DIMENSIONS - LONG WHEELBASE

### Vehicle Dimensions

<b>Dimension Description</b>	<b>mm (in)</b>
Maximum length.	4,825 (190.0)
Overall width including exterior mirrors.	2,137 (84.1)
Overall height - EC curb weight.	1,845 (72.6)
Wheelbase.	3,052 (120.2)
Front track.	1,568 (61.7)
Rear track.	1,582 (62.3)

## VEHICLE DIMENSIONS - SHORT WHEELBASE COM KOMBI

### Vehicle Dimensions

<b>Dimension Description</b>	<b>mm (in)</b>
Maximum length.	4,425 (174.2)
Overall width including exterior mirrors.	2,137 (84.1)
Overall height - EC curb weight.	1,820 (71.7)
Wheelbase.	2,662 (104.8)
Front track.	1,568 (61.7)
Rear track.	1,582 (62.3)

# Capacities and Specifications

---

## VEHICLE DIMENSIONS - SHORT WHEELBASE DOUBLE CAB IN VAN, TRANSIT

### Vehicle Dimensions

<b>Dimension Description</b>	<b>mm (in)</b>
Maximum length.	4,425 (174.2)
Overall width including exterior mirrors.	2,137 (84.1)
Overall height - EC curb weight.	1,861 (73.3)
Wheelbase.	2,662 (104.8)
Front track.	1,568 (61.7)
Rear track.	1,582 (62.3)

## VEHICLE DIMENSIONS - SHORT WHEELBASE

### Vehicle Dimensions

<b>Dimension Description</b>	<b>mm (in)</b>
Maximum length.	4,425 (174.2)
Overall width including exterior mirrors.	2,137 (84.1)
Overall height - EC curb weight.	1,852 (72.9)
Wheelbase.	2,662 (104.8)
Front track.	1,568 (61.7)
Rear track.	1,582 (62.3)

# Capacities and Specifications

## TOWBAR DIMENSIONS

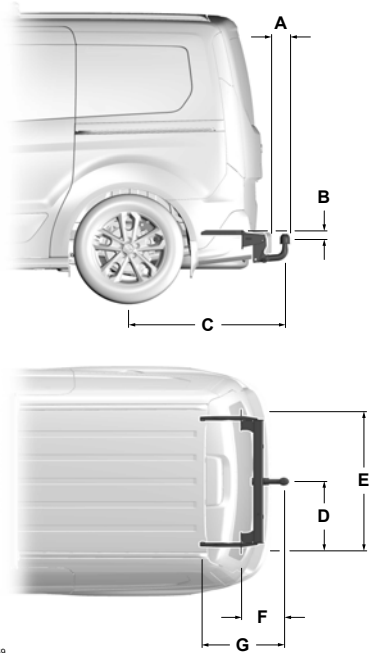

E163459

Item	Dimension description	mm (in)
A	Bumper to end of tow ball	113 (4.4)
B	Attachment point to center of tow ball	21 (0.8)
C	Wheel center to center of tow ball	963 (37.9)
D	Center of tow ball to side member	493 (19.4)
E	Distance between side members	986 (38.8)
F	Center of tow ball to center of attachment point one	268 (10.6)
G	Center of tow ball to center of attachment point two	505 (19.9)

# Capacities and Specifications

## Maximum Permissible Nose Weight

kg (lb)
75 kg (165 lb)

## VEHICLE IDENTIFICATION PLATE

**Note:** Your vehicle identification plate design may vary to that shown.

**Note:** The information shown on the vehicle identification plate is dependent upon market requirements.

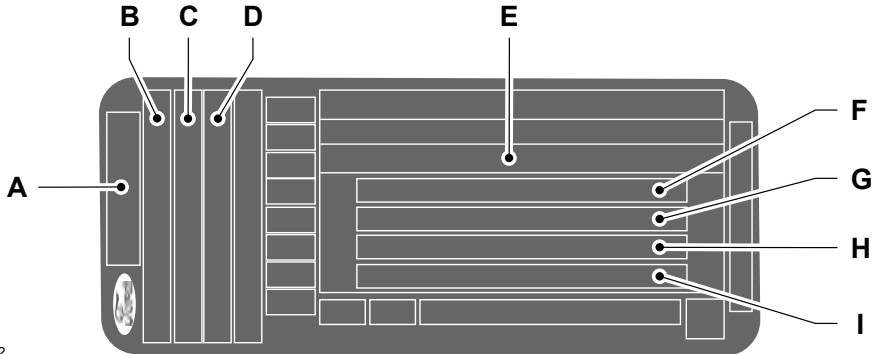

E135662

- A Model
- B Variant
- C Engine designation
- D Engine power and emission level
- E Vehicle identification number
- F Gross vehicle weight
- G Gross train weight
- H Maximum front axle weight
- I Maximum rear axle weight

Your vehicle identification number and maximum weights are shown on a plate, located at the bottom of the lock side of the right-hand door aperture.

# Capacities and Specifications

## VEHICLE IDENTIFICATION NUMBER

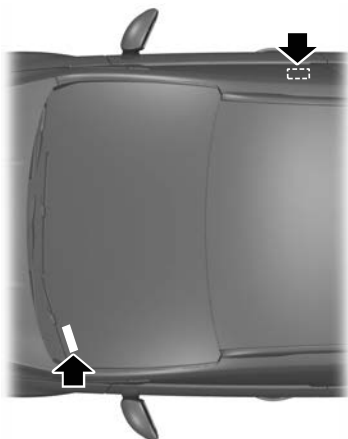

E87496

The vehicle identification number is stamped into the floor panel on the right-hand side, beside the front seat. It is also shown on the left-hand side of the instrument panel.

## CAPACITIES AND SPECIFICATIONS - 1.0L ECOBOOST™

Use oil and fluid that meets the defined specification and viscosity grade.

If you do not use oil and fluid that meets the defined specification and viscosity grade, it could result in:

- Component damage not covered by the vehicle Warranty.
- Longer engine cranking periods.
- Increased emission levels.
- Reduced engine performance.
- Reduced fuel economy.
- Reduced brake performance.

## Air Conditioning System



**WARNING:** The air conditioning refrigerant system contains refrigerant under high pressure. Only qualified personnel should service the air conditioning refrigerant system. Opening the air conditioning refrigerant system can cause personal injury.

Variant	Global Warming Potential	CO <sub>2</sub> Equivalent
All.	1430	0.83 tonnes

## Capacities

Variant	Refrigerant	Refrigerant Oil
All.	0.58 kg (20.5 oz)	120 cm <sup>3</sup> (4.1 fl oz)

# Capacities and Specifications

## Materials

Name	Specification
Refrigerant - R-134A	WSH-M17B19-A
Compressor Oil - Air Conditioning 6U7J-M1C231-CA	WSH-M1C231-B

## Engine

### Engine Oil

#### Capacities

Variant	Including the Oil Filter	Excluding the Oil Filter
All.	4.97 L (1.1 gal)	4.87 L (1.1 gal)

**Note:** The quantity of engine oil required to raise the indicated level on the dipstick from minimum to maximum is 1.5 L (0.3 gal).

## Materials

Name	Specification
Engine Oil - SAE 5W-20	WSS-M2C948-B

If you are unable to find an engine oil that meets the specification defined by WSS-M2C948-B, it is acceptable to use a SAE 5W-20 engine oil that is defined by ACEA C2.

**Note:** Do not use more than 1 L (0.2 gal) of the alternative engine oil between scheduled service intervals.

## Engine Coolant

#### Capacities

Variant	Quantity
Vehicles with a manual transmission.	5.5 L (1.2 gal)
Vehicles with an automatic transmission.	5.8 L (1.3 gal)

# Capacities and Specifications

## Materials

Name	Specification
Antifreeze Super Plus Premium FU7J-19544-xx	WSS-M97B44-D

## Fuel Tank

### Capacities

Variant	Quantity
All.	56 L (12.3 gal)

## Washer Reservoir

### Capacities

Variant	Quantity
All.	3 L (0.7 gal)

## Materials

Name	Specification
Screen Wash FU7J-19C544-AA/BA/DA/EA/GA/HA	WSS-M14P19-A

## Brake System

### Materials

Name	Specification
Brake Fluid DOT 4 LV High Performance BU7J-M6C65-xxxx	WSS-M6C65-A2

# Capacities and Specifications

## CAPACITIES AND SPECIFICATIONS - 1.5L ECOBLUE

Use oil and fluid that meets the defined specification and viscosity grade.

If you do not use oil and fluid that meets the defined specification and viscosity grade, it could result in:

- Component damage not covered by the vehicle Warranty.
- Longer engine cranking periods.
- Increased emission levels.

- Reduced engine performance.
- Reduced fuel economy.
- Reduced brake performance.

### Air Conditioning System



**WARNING:** The air conditioning refrigerant system contains refrigerant under high pressure. Only qualified personnel should service the air conditioning refrigerant system. Opening the air conditioning refrigerant system can cause personal injury.

Variant	Global Warming Potential	CO <sub>2</sub> Equivalent
All.	1430	0.83 tonnes

### Capacities

Variant	Refrigerant	Refrigerant Oil
All.	0.58 kg (20.5 oz)	120 cm <sup>3</sup> (4.1 fl oz)

### Materials

Name	Specification
Refrigerant - R-134A	WSH-M17B19-A
Compressor Oil - Air Conditioning 6U7J-M1C231-CA	WSH-M1C231-B

### Engine

#### Engine Oil

An engine oil viscosity grade and specification label is on the underside of the hood.

# Capacities and Specifications

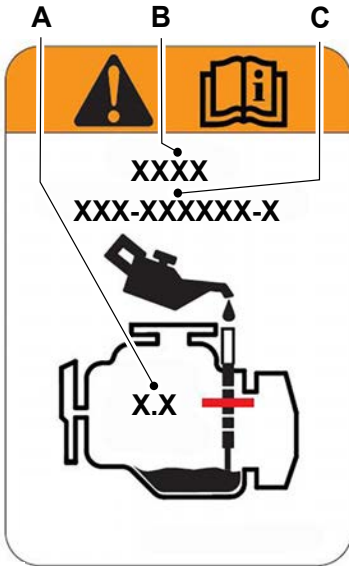

E248032

- A Engine oil fill capacity including the oil filter.
- B Engine oil viscosity grade.
- C Engine oil specification.

## Adding Engine Oil

Only add engine oil that meets the defined specification and viscosity grade in small quantities of no more than 0.5 L (0.11 gal).

Wait for one minute after each refill step to allow the engine oil to flow into the oil pan and register on the engine oil dipstick. See **Engine Oil Check** (page 245).

## Fuel Tank

### Capacities

Variant	Quantity
All.	52 L (11.4 gal)

## Diesel Exhaust Fluid (AdBlue) Tank

### Capacities

Variant	Quantity
All.	17.6 L (3.9 gal)

# Capacities and Specifications

## Washer Reservoir

### Capacities

Variant	Quantity
All.	3 L (0.7 gal)

### Materials

Name	Specification
Screen Wash FU7J-19C544-AA/BA/DA/EA/GA/HA	WSS-M14P19-A

## Brake System

### Materials

Name	Specification
Brake Fluid DOT 4 LV High Performance BU7J-M6C65-xxxx	WSS-M6C65-A2

## BULB SPECIFICATION CHART

### Exterior Lamps

Lamp	Specification	Power (Watts)
Daytime running lamp.	LED (light emitting diode).	-
Front direction indicator.	PW24W.	24
Headlamp low beam - vehicles with halogen headlamps.	H7.	55
Headlamp high beam - vehicles with halogen headlamps.	H15.	55
Headlamp - vehicles with high intensity discharge headlamps.	D8S.	25
Cornering lamp.	H1.	55

## Capacities and Specifications

Lamp	Specification	Power (Watts)
Front fog lamp.	H11.	55
Direction indicator side repeater.	WY5W.	5
Approach lamp.	W5W.	5
Rear lamp and stoplamp.	P21/5W.	21/5
High mounted stoplamp.	LED.	-
Rear direction indicator.	PY21W.	21
Rear fog lamp.	P21W.	21
Reversing lamp.	W16W.	16
License plate lamp. <sup>1</sup>	W5W.	5

<sup>1</sup> Licence plate lamps are also available as LED lamps.

**Note:** We recommend that you have LED changed by an authorized dealer.

### Interior Lamps

Lamp	Specification	Power (Watts)
Cargo lamp - vehicles without LED cargo lamps.	Festoon.	10
Cargo lamp - vehicles with LED cargo lamps.	LED.	-
Luggage compartment lamp.	LED.	-
Map reading lamp.	W6W.	6
Interior lamp.	W6W.	6

**Note:** We recommend that you have LED changed by an authorized dealer.

# Capacities and Specifications

## FUEL CONSUMPTION FIGURES

### Fuel Economy and CO2 Emissions

The declared fuel/energy consumptions, CO<sub>2</sub>-Emissions and electric range are measured according to the technical requirements and specifications of the European Regulations (EC) 715/2007 and (EC) 692/2008 as last amended. Fuel consumption and CO<sub>2</sub>-Emissions are specified for a vehicle variant and not for a single car. The applied standard test procedure enables comparison between different vehicle types and different manufacturers.

### European Directive 1999/94/EC

In addition to the fuel efficiency of a car, driving behaviour as well as other non-technical factors play a role in determining a car's fuel consumption and CO<sub>2</sub> emissions. CO<sub>2</sub> is the main greenhouse gas responsible for global warming. A guide on fuel economy and CO<sub>2</sub> emissions which contains data for all new passenger car models is available at any point of sale free of charge.

## World Harmonised Light Vehicle Test Procedure

From 1 September 2017, certain new vehicles will be type-approved using the World Harmonised Light Vehicle Test Procedure (WLTP) according (EU) 2017/1151 as last amended, which is a new, more realistic test procedure for measuring fuel consumption and CO<sub>2</sub> emissions. From 1 September 2018 the WLTP will fully replace the New European Drive Cycle (NEDC), which is the current test procedure. During NEDC Phase-out, WLTP fuel consumption and CO<sub>2</sub> emissions are being correlated back to NEDC. There will be some variance to the previous fuel economy and emissions as some elements of the tests have altered i.e., same car might have different fuel consumption and CO<sub>2</sub> emissions.

## FUEL CONSUMPTION FIGURES - 1.0L ECOBOOST™

Urban	Extra-Urban	Combined	CO <sub>2</sub> Emissions
L/100 km (mpg)	L/100 km (mpg)	L/100 km (mpg)	g/km
7.1–6.8 (40–42)	5.8–5.5 (49–51)	6.3–5.9 (45–48)	135–142

# Capacities and Specifications

---

## FUEL CONSUMPTION FIGURES - 1.5L ECOBLUE

<b>Urban</b>	<b>Extra-Urban</b>	<b>Combined</b>	<b>CO<sub>2</sub> Emissions</b>
<b>L/100 km (mpg)</b>	<b>L/100 km (mpg)</b>	<b>L/100 km (mpg)</b>	<b>g/km</b>
5.7-4.7 (50-60)	5.2-4.2 (54-67)	5.3-4.5 (53-63)	115-139

# Network Connectivity

---

## CONNECTING THE VEHICLE TO A MOBILE NETWORK

### About the Modem - Vehicles Without: SYNC 3

The modem allows you to connect your vehicle to the Internet to use when you are on the road.

If you enable the modem using the FordPass app, you can access the following services:

- Locating and remotely starting, locking and unlocking your vehicle. See the information in FordPass app.
- Automatic system updates.

### Enabling the Modem Using FordPass

1. Open the FordPass app on your device and log in.
2. Select your vehicle.
3. Select the option for vehicle details.
4. Select the option to activate your vehicle.
5. Switch the ignition on.
6. Make sure that the name on the screen matches the name shown in your FordPass account.
7. Confirm the association of your vehicle with your FordPass account.

# Network Connectivity

## NETWORK CONNECTIVITY – TROUBLESHOOTING

### Wi-Fi Network

Symptom	Possible Cause and Resolution
I cannot connect to a Wi-Fi network.	<ul style="list-style-type: none"><li>– Password error.<ul style="list-style-type: none"><li>• Enter the correct network password.</li></ul></li><li>– Weak network signal.<ul style="list-style-type: none"><li>• Move your vehicle closer to the Wi-Fi hotspot or to a place where the network signal is not obstructed.</li></ul></li><li>– Multiple access points in range with the same SSID.<ul style="list-style-type: none"><li>• Use a unique name for your SSID. Do not use the default name unless it contains a unique identifier, for example as part of the MAC address.</li></ul></li></ul>
The Wi-Fi connection disconnects after successful connection.	<ul style="list-style-type: none"><li>– Weak network signal.<ul style="list-style-type: none"><li>• Move your vehicle closer to the Wi-Fi hotspot or to a place where the network signal is not obstructed.</li></ul></li></ul>
I am close to a Wi-Fi hotspot but the network signal strength is weak.	<ul style="list-style-type: none"><li>– Obstructed network signal.<ul style="list-style-type: none"><li>• If your vehicle has a heated windshield, position your vehicle so that the windshield is not facing the Wi-Fi hotspot.</li><li>• If your vehicle has metallic tinting on the windows but not on the windshield, position your vehicle so that the windshield is facing the Wi-Fi hotspot or open the windows that are facing the hotspot.</li><li>• If your vehicle has metallic tinting on the windows and the windshield, open the windows that are facing the hotspot.</li><li>• If your vehicle is in a garage and you have the garage door closed, open the garage door.</li></ul></li></ul>
I cannot see a network in the list of available networks that I expect to see.	<ul style="list-style-type: none"><li>– Hidden network.<ul style="list-style-type: none"><li>• Make the network visible and try again.</li></ul></li></ul>

# Network Connectivity

Symptom	Possible Cause and Resolution
I cannot see the Wi-Fi Hotspot name when I search for Wi-Fi networks on my cell phone or other device.	<ul style="list-style-type: none"> <li>- System limitation.               <ul style="list-style-type: none"> <li>• Make sure Wi-Fi hotspot visibility is on.</li> <li>• The system does not provide a Wi-Fi hotspot at this time.</li> </ul> </li> </ul>
Software downloads take too long.	<ul style="list-style-type: none"> <li>- Weak network signal               <ul style="list-style-type: none"> <li>• Move your vehicle closer to the Wi-Fi hotspot or to a place where the network signal is not obstructed.</li> </ul> </li> <li>- Wi-Fi hotspot in high demand or has a slow Internet connection.               <ul style="list-style-type: none"> <li>• Use an more reliable Wi-Fi hotspot.</li> </ul> </li> </ul>
The system seems to connect to a Wi-Fi network and the signal strength is excellent but the software does not update.	<ul style="list-style-type: none"> <li>- No software update available.</li> <li>- Wi-Fi network requires a subscription or acceptance of terms and conditions.               <ul style="list-style-type: none"> <li>• Test the connection using another device. If the network requires a subscription or acceptance of terms and conditions, contact the network service provider.</li> </ul> </li> </ul>

## Mobile Network

Symptom	Possible Cause and Resolution
I cannot confirm association with FordPass when trying to enable the modem.	<ul style="list-style-type: none"> <li>- Modem is not enabled.               <ul style="list-style-type: none"> <li>• Enable the modem through FordPass.</li> </ul> </li> <li>- Weak network signal.               <ul style="list-style-type: none"> <li>• Move your vehicle closer to a place where the network signal is not obstructed.</li> </ul> </li> </ul>

# Wi-Fi Hotspot

## CREATING A WI-FI HOTSPOT - VEHICLES WITHOUT: SYNC 3

You can create a Wi-Fi hotspot in your vehicle and allow devices to connect to it for access to the Internet.



Press the button to enter the settings menu.

1. Select **Connectivity features**.
2. Select **Vehicle Hotspot**.

**Note:** The vehicle hotspot default setting is on.

3. Select **Settings**.
4. Select **Wi-Fi visibility**.

**Note:** The Wi-Fi Visibility default setting is on.

### Finding the Wi-Fi Hotspot Name and Password



Press the button to enter the settings menu.

1. Select **Connectivity features**.
2. Select **Vehicle Hotspot**.
3. Select **Settings**.

**Note:** The SSID is the hotspot name.

4. Scroll to **Hide password**.
5. Uncheck the box.

### Connecting a Device to the Wi-Fi Hotspot

1. On your device, turn on Wi-Fi and select the hotspot from the list of available Wi-Fi networks.
2. When prompted, enter the password.

### Purchasing a Data Plan

1. Connect a device to the hotspot.

**Note:** The vehicle network carrier's portal opens on your device.

2. If the portal does not open on your device, open a website and it redirects to the vehicle network carrier's portal.

**Note:** Secure websites do not redirect.

**Note:** If you have an active plan, the system does not redirect to the vehicle network carrier's portal when you connect a device. Visit the vehicle network carrier's website to purchase more data.

**Note:** If data usage information is available in the vehicle hotspot menu, it is approximate.

**Note:** If you carry out a master reset, the system does not remove your vehicle from your vehicle network carrier's account. To remove your vehicle from the account, contact your vehicle network carrier.

**Note:** The vehicle network carrier provides Vehicle Hotspot services, subject to your vehicle network carrier agreement, coverage and availability.

## CHANGING THE WI-FI HOTSPOT NAME OR PASSWORD - VEHICLES WITHOUT: SYNC 3



Press the button to enter the settings menu.

1. Select **Connectivity features**.
2. Select **Vehicle Hotspot**.
3. Select **Settings**.
4. Select **SSID: \_\_\_**.
5. Enter your required SSID.
6. Select **Done**.
7. Select **Password: \_\_\_**.
8. Enter your required password.

# Wi-Fi Hotspot

---

9. Select **Done**.

# Audio System

## AUDIO UNIT - VEHICLES WITHOUT: SYNC 3

### Switching the Audio Unit On and Off

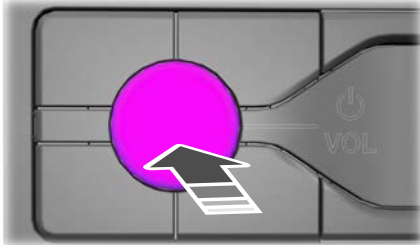

E260686

### Adjusting the Volume



E248939

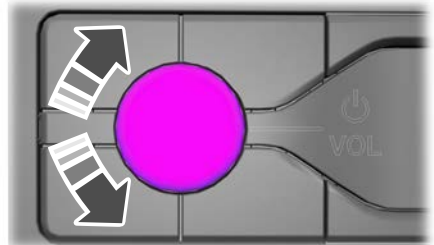

E260697

### Selecting the Radio



Press the button to select radio mode.

Press the button again to display the available radio sources. Repeatedly press the button to scroll through the available radio sources.

### Changing Radio Stations

#### Manual Tuning

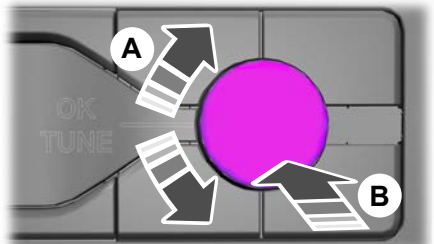

E260687

- A Tune by station list or tune by frequency.
- B Station list tuning.

# Audio System



E248947

**Note:** You can change radio stations using the seek buttons.

**Note:** You can recall radio stations using the numeric preset buttons.

## Selecting Media



Press the button to select media mode.

Press the button again to display the available media sources. Repeatedly press the button to scroll through the available media sources.

## Scrolling Through the Menu Options



E248947

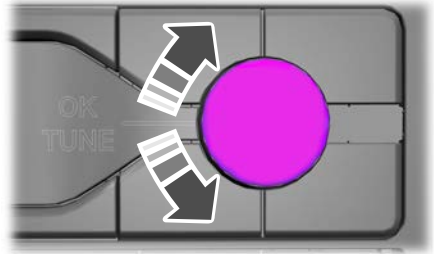

E260782

# Audio System

## Selecting a Menu Option



E248946

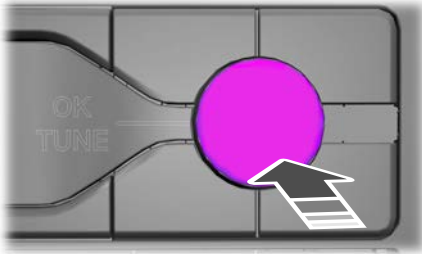

E260781

## Returning to the Previous Screen



## Seek Up and Next Track Button



## Seek Down and Previous Track Button



## Pausing or Playing Media



In media mode, press the button to pause playback. Press the button again to resume playback.

In radio mode, press the button to mute the radio. Press the button again to unmute.

## Switching the Screen On and Off



## System Settings



## Sound Settings



Press the button to adjust the sound settings. You can optimize the sound for different seating positions.

You can also activate and set the sensitivity of the speed compensated volume.

## Using a Cell Phone



You can make a call from a recent call list, contact list or dial a number.

## AUDIO UNIT - VEHICLES WITH: SYNC 3

## Switching the Audio Unit On and Off



# Audio System

## Adjusting the Volume



E248939

## Changing Radio Stations

### Manual Tuning



E270235

**Note:** You can change radio stations using the seek buttons.

**Note:** You can recall radio stations using the preset buttons on the touchscreen.

### Seek Up and Next Track Button



Select to skip to the next track.

Press and hold the button to fast forward through the track.

### Seek Down and Previous Track Button



Select to return to the beginning of a track.

Repeatedly press the button to return to previous tracks.

Press and hold the button to fast rewind.

### Pausing or Playing Media



Select to play a track. Press the button again to pause the track.

In radio mode, press the button to mute the radio. Press the button again to unmute.

### Switching the Screen On and Off



### Sound Settings



Press the button to adjust the sound settings. You can optimize the sound for different seating positions.

You can also activate and set the sensitivity of the speed compensated volume.

## AM/FM RADIO - VEHICLES WITHOUT: SYNC 3

### Selecting a Radio Source



Press the button to display the available radio sources.

# Audio System

Repeatedly press the button to scroll to the desired radio source.

Press the **OK** button.

## Station Presets

To store a radio station, press and hold one of the numeric preset buttons.

**Note:** Six presets can be stored for each radio source.

## Manually Changing Radio Stations



E248947

Rotate the control to change the frequency.

## Automatically Changing Radio Stations



Press to seek the next station up the frequency band.

Press and hold to quickly seek up the frequency band.



Press to seek the next station down the frequency band.

Press and hold to quickly seek down the frequency band.

## Selecting a Station from the List

Press the **OK** button to view available stations.

## DIGITAL RADIO - VEHICLES WITHOUT: SYNC 3

## Selecting a Radio Source



Press the button to display the available radio sources.

Repeatedly press the button to scroll to the desired radio source.

Press the **OK** button.

## Station Presets

To store a station, press and hold one of the numeric preset buttons.

**Note:** Six presets can be stored for each radio source.

## Manually Changing Stations



E248947

Rotate the control to change the station.

# Audio System

## Automatically Changing Radio Stations



Press to seek the next station up the frequency band.

Press and hold to quickly seek up the frequency band.



Press to seek the next station down the frequency band.

Press and hold to quickly seek down the frequency band.

## Selecting a Station from the List

Press the **OK** button to view available ensembles. Select the desired ensemble and station from the list.

## AUDIO UNIT CLOCK AND DATE DISPLAYS - VEHICLES WITHOUT: SYNC 3

### Adjusting the Clock



Press the button.

Select the clock and follow the instructions on the screen.

## CONNECTING A BLUETOOTH DEVICE - VEHICLES WITHOUT: SYNC 3

### Pairing a Device



Press the button.

Select Bluetooth and follow the instructions on the screen.

**Note:** When pairing a new device, you can choose to download contacts, set this as the primary device and enable Emergency Assistance.

## STREAMING BLUETOOTH AUDIO - VEHICLES WITHOUT: SYNC 3

### Selecting a Bluetooth Source



Press the button to display the menu.

Repeatedly press the button to scroll to the Bluetooth device.

Press the **OK** button.



Press the button to play the track. Press the button again to pause the track.



Press the button to skip to the next track.

Press and hold the button to fast forward through the track.



Press the button once to return to the beginning of the track.

Repeatedly press the button to return to previous tracks.

Press and hold the button to fast rewind.

**Note:** Not all functions are supported by all phones.

## PLAYING MEDIA FROM A USB DEVICE - VEHICLES WITHOUT: SYNC 3

### Supported Audio File Formats

You can play audio file formats including MP3, WMA, WAV, M4A, M4B, AAC, and FLAC.

# Audio System

**Note:** The NTFS file system is not supported.

## Selecting the USB Device



Press the button to display the menu.

Repeatedly press the button to scroll to your USB device.

Press the **OK** button.

## Playing from the USB Device



Press the button to play a track. Press the button again to pause the track.



Press the button to skip to the next track.

Press and hold the button to fast forward through the track.



Press the button once to return to the beginning of a track. Repeatedly press the button to return to previous tracks.

Press and hold the button to fast rewind.

## Sorting by Categories

You can also sort and play music by specific categories, for example artist or album.

Press the **OK** button to view the available categories.

## USB PORT

USB Ports could be in the following locations:

- On the center console below the gearshift lever.
- Under the front passenger double seat cushion.

You can use the USB port to charge a device only when the engine is running.

## USING VOICE RECOGNITION

### Phone Voice Service

This system allows you to use the voice recognition features of your phone and focus on your driving.



Press and hold the voice control button on the steering wheel.

**Note:** This only works when connected via Bluetooth. See **Connecting a Bluetooth Device** (page 306).

**Note:** When using voice recognition use the language set on the device.

## GENERAL INFORMATION



**WARNING:** Driving while distracted can result in loss of vehicle control, crash and injury. We strongly recommend that you use extreme caution when using any device that may take your focus off the road. Your primary responsibility is the safe operation of your vehicle. We recommend against the use of any hand-held device while driving and encourage the use of voice-operated systems when possible. Make sure you are aware of all applicable local laws that may affect the use of electronic devices while driving.

## About SYNC

The system allows you to interact with the entertainment, information and communication systems on your vehicle using voice commands and a touchscreen. The system provides easy interaction with audio, phone, navigation, mobile apps and settings.

**Note:** You can switch the system on and use it for up to an hour without switching the ignition on.

**Note:** You can use the system after you switch the ignition off for up to 10 minutes or until you open a door.





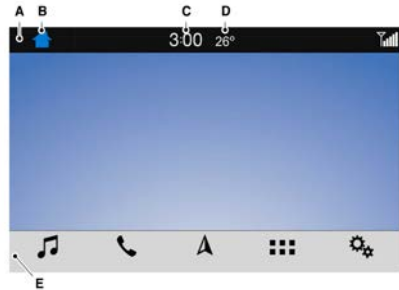

**Note:** For your safety, some features are speed-dependent. Their use is limited to when your vehicle speed is less than 5 km/h (3 mph).

## Using the Touchscreen



- A Status bar.
- B Home screen. See **Home Screen** (page 311).
- C Clock. See **Settings** (page 325).
- D Outside air temperature.
- E Feature bar.

## Status Bar

-  Cell phone microphone muted.
-  Audio system muted.
-  Software update installed.
-  Wi-Fi connected.
-  Cell phone roaming.
-  Text message received.
-  Emergency Assistance off.



Cell phone network signal strength.



Vehicle data sharing on.



Vehicle location sharing on.



Vehicle data and vehicle location sharing on.



Live traffic connected.



Live traffic broadcast.

## Feature Bar



Select to use the radio, a USB, a media player or a Bluetooth device. See **Entertainment** (page 316).



Select to make calls and access the phonebook on your cell phone. See **Phone** (page 318).



Select to use the navigation system. See **Navigation** (page 320).



Select to search for and use compatible apps on your iOS or Android device. See **Apps** (page 324).



Select to adjust system settings. See **Settings** (page 325).

## Cleaning the Touchscreen

See **Cleaning the Interior** (page 257).

## Modem (If Equipped)

The modem allows you to connect your vehicle to the Internet to use when you are on the road.

If you enable the modem using the FordPass app, you can access the following services:

- Wi-Fi hotspot.
- Live traffic. See **Navigation** (page 320).
- Locating and remotely starting, locking and unlocking your vehicle. See the information in FordPass app.
- Automatic software updates.

If you do not enable the modem using the FordPass app, you can still enable the modem using the touchscreen to get automatic software updates.

## Enabling the Modem Using the FordPass App

1. Open the FordPass app on your device and log in.
2. Select your vehicle.
3. Select the option for vehicle controls.
4. Select the option to enable the modem.
5. Switch the ignition on.
6. Confirm the association of your vehicle with your FordPass account on the touchscreen.

## Enabling the Modem Using the Touchscreen



Select the settings option on the feature bar.

1. Select **SYNC Connect**.
2. Select **Connectivity settings**.
3. Switch **Connectivity features** on.
4. Switch **Send vehicle data** on.

## Wi-Fi Hotspot

You can create a Wi-Fi hotspot in your vehicle and allow up to 10 devices to connect to it for access to the Internet.

### Creating a Wi-Fi Hotspot



Select the settings option on the feature bar.

1. Select **Wi-Fi & Hotspot**.
2. Select **Vehicle Hotspot**.
3. Switch **Wi-Fi Hotspot** on.

**Note:** Select **Settings** and then select **Edit** to view or change the Wi-Fi hotspot SSID or password.

4. Switch **Wi-Fi visibility** on.

## Updating the System

### Updating the System Using a USB Drive

#### Downloading an Update

1. Go to the SYNC update page on the regional Ford website.
2. Download the update.

**Note:** The website notifies you if an update is available.

3. Insert a USB drive into your computer.

**Note:** The USB drive needs to be empty and meet the minimum requirements detailed on the website.

4. Follow the instructions provided to download the update to the USB drive.

#### Installing an Update

**Note:** You can use the system when an installation is in progress.

1. Disconnect all other USB devices from the USB ports.
2. Connect the USB drive with the update to a USB port.

**Note:** Installation starts automatically within 10 minutes.

## Updating the System Using a Wi-Fi Network Connection

### Connecting to a Wi-Fi Network



Select the settings option on the feature bar.

Select **System Wi-Fi**.

Select **Available Wi-Fi networks**.

Select an available Wi-Fi network.

**Note:** Enter the network password to connect to a secure network.

### Switching Automatic System Updates On



Select the settings option on the feature bar.

Select **General**.

Select **Automatic system updates**.

Switch automatic system updates on.

The system is now set to check for and receive system updates when it is connected to a Wi-Fi network.

**Note:** You can use the system when a download is in progress.

**Note:** If the system is disconnected from the Wi-Fi network when a download is in progress, the download continues the next time the system is connected to a Wi-Fi network.

## Additional Information and Assistance

For additional information and assistance, we recommend that you contact an authorized dealer or refer to the regional Ford website.

**Note:** If you switch vehicle location or vehicle data sharing on and you do not have a device paired with your vehicle, a prompt appears on the touchscreen to remind you that vehicle location or vehicle data sharing is on. Pair a device to stop the prompt from appearing. See **Phone** (page 318).

## HOME SCREEN

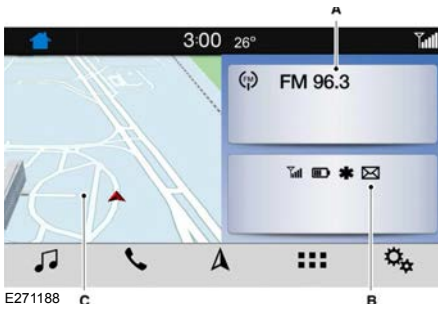

- A See **Entertainment** (page 316).
- B See **Phone** (page 318).
- C See **Navigation** (page 320).

## General

Voice Command	Description
___ list of commands	Get a list of voice commands for a specific feature. <sup>1</sup>
Cancel	Cancel an active voice session.
___ help	Get a list of voice commands for a specific feature. <sup>1</sup>
Back	Return to the previous screen.
Main menu	Go to the main menu.

## USING VOICE RECOGNITION

The system allows you to interact with the entertainment, information and communication systems on your vehicle using voice commands. This allows you to keep your hands on the steering wheel and focus on what is in front of you.



Press the voice control button on the steering wheel and wait for the voice prompt.

**Note:** Press the voice control button again to interrupt a voice prompt and begin speaking.

**Note:** Turn the volume control when a voice prompt plays to adjust the volume.

**Note:** Press and hold the voice control button on the steering wheel to use Siri on your iOS device.

The following voice commands are designed to help you from any screen:

- **List of commands**
- **Help**

The following tables list some of the more frequently used voice commands. For a complete list of voice commands, refer to the regional Ford website.

# SYNC™ 3

Voice Command	Description
Next page	Go to the next page.
Previous page	Go to the previous page.

<sup>1</sup> Add the name of the feature to the command.

## Entertainment

### Audio Source

Voice Command	Description
Radio	Use the radio.
CD Player	Use the CD player.
Bluetooth audio	Use a Bluetooth device.
USB	Use a USB or media player.

### Radio

Voice Command	Description
AM	Listen to AM radio.
___ AM	Tune to a specific AM frequency. <sup>1</sup>
DAB	Listen to DAB radio.
FM	Listen to FM radio.
___ FM	Tune to a specific FM frequency. <sup>1</sup>

<sup>1</sup> Add the radio frequency to two decimal places to the command.

# SYNC™ 3

## USB and Media Player

Voice Command	Description
Browse all albums	Browse your music.
Browse all artists	
Browse all audiobooks	
Browse all genres	
Browse all playlists	
Browse all podcasts	
Browse all tracks	
Browse album ___	Browse your music by category. <sup>1</sup>
Browse artist ___	
Browse audiobook ___	
Browse genre ___	
Browse playlist ___	
Browse podcast ___	
Play album ___	Play your music by category. <sup>1</sup>
Play artist ___	
Play genre ___	
Play playlist ___	
Play song ___	

<sup>1</sup> Add an album name, artist name, audiobook name, genre name, playlist name, podcast name or track name to the command. Say the name exactly as it appears on your device.

## Phone

Voice Command	Description
Pair phone	Pair a cell phone or Bluetooth enabled device.
Redial	Redial the last number that you dialed.
Dial ___	Dial a number. <sup>1</sup>

# SYNC™ 3

Voice Command	Description
Call ___	Call a specific contact from your phonebook. <sup>2</sup>
Call ___ ___	Call a specific contact from your phonebook at a specific location. <sup>3</sup>
Listen to message	Listen to a text message.
Listen to message ___	Listen to a specific text message from a list of text messages.
Reply to message	Reply to the last text message.

<sup>1</sup> Add the number you want to dial to the command.

<sup>2</sup> Add a contact name from your phonebook to the command. Say the first and last name of your contact exactly as it appears on your device.

<sup>3</sup> Add a contact name and location from your phonebook to the command. Say the first and last name of your contact exactly as it appears on your device.

## Navigation (If Equipped)

### Setting a Destination

Voice Command	Description
Find an address	Enter a destination address. When prompted, provide the house number, the street and city.
Find a POI	Search for a point of interest by name or by category.
Find nearest ___	Search for a nearby point of interest by category. <sup>1</sup>
Find a POI category	Search for a point of interest category. <sup>1</sup>
Destination home	Set your saved home address as your destination.
Destination work	Set your saved place of work as your destination.
Previous destinations	Display and select from a list of previous destinations.
Favourite destinations	Display and select from a list of favorite destinations.

<sup>1</sup> Add a point of interest name or category to the command.

## Route Guidance

Voice Command	Description
Cancel route	Cancel the current route.
Reroute	Select an alternate route.
Repeat last instruction	Repeat the last guidance prompt.
Show route	Display an overview of the route.
Show traffic	Display a list of traffic events on your route.
Show all traffic	Display a list of all traffic events.
Show map	Display the map on the touchscreen.
Show north up	Display a two-dimensional map with north toward the top of the touchscreen.
Show heading up	Display a two-dimensional map with the direction you are traveling toward the top of the touchscreen.
Show 3D	Display a three-dimensional map with the direction you are traveling toward the front.

## Apps

### General

Voice Command	Description
Mobile apps	Start an app. The system prompts your for the app name.
List apps	Get a list of apps running on your device.
Find apps	Search and connect to apps running on your device.

### Active App

Voice Command	Description
___ help	Get a list of voice commands for a specific app. <sup>1</sup>
Close ___	Close an app. <sup>1</sup>

<sup>1</sup> Add an app name to the command.

## Voice Settings

Voice Command	Description
Voice settings	Go to the voice settings menu.
Interaction mode standard	Switch long voice prompts on.
Interaction mode advanced	Switch short voice prompts on.
Call confirmation on	Switch call confirmation on. The system prompts you to confirm before making a call.
Call confirmation off	Switch call confirmation off. The system does not prompt you to confirm before making a call.
Voice command lists on	Display the display of voice commands on.
Voice command lists off	Switch the display of voice commands off.

## Automatic Blower Motor Speed Reduction

If necessary, the system decreases the blower motor speed when you are using voice commands to reduce the amount of background noise in your vehicle. It returns to normal when you are finished.

## Switching Automatic Blower Motor Speed Reduction Off

Simultaneously press the **A/C** and recirculated air buttons.

## ENTERTAINMENT



Select the entertainment option on the feature bar.

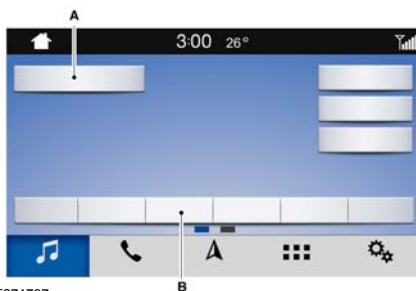

E271797

- A Audio source. Select to choose a different audio source.
- B Presets. Swipe left to view more presets.

## Using the Radio

### Setting a Radio Station Using the Touchscreen

#### Directly Tuning a Radio Station

Select **Sources**.

Select **AM** or **FM**.

Select **Frequency**.

Enter the frequency of the radio station and select **Enter**.

**Note:** You must enter the frequency to two decimal places.

## Selecting a Radio Station From a List

Select **Sources**.

Select **FM** or **DAB**.

Select **Station**.

Select a radio station from the list.

## Switching Traffic Announcements On

Select **Traffic (TA)**.

**Note:** If you switch traffic announcements on, traffic announcements broadcast by radio stations interrupt the current audio source to help you plan your route.

## Storing a Radio Station

You can use the different sets of presets to allow different drivers to store their favorite radio stations.

Set a radio station.

Select **Presets**.

**Note:** Only do this if you wish to select a different set of presets.

Press and hold one of the preset buttons.

**Note:** The radio briefly mutes to indicate the radio station has been stored.

## Streaming Music From a Bluetooth Device

Check the compatibility of your device on the regional Ford website.

Pair your device. See **Phone** (page 318).

Select **Sources**.



Select **Bluetooth**.

## Searching for Tracks on a Bluetooth Device

Select **Stations**.

Select a track.

**Note:** Select the cover art to view information about the current track.

## Repeating Tracks on a Bluetooth Device



Select the repeat icon to repeat tracks.

**Note:** You can repeat one track or all tracks on an audio format Bluetooth device. You can repeat one track, all tracks or all tracks in one folder on a Bluetooth device.

**Note:** A small number one appears next to the repeat icon to indicate that a track is set to repeat. A small folder icon appears next to it to indicate that a folder is set to repeat

## Playing Tracks on a Bluetooth Device in a Random Order



Select to play tracks in a random order.

## Playing Music From a USB or Media Player

Connect your device to a USB port.

Select **Sources**.



Select **USB**.

**Note:** The system indexes your music before you can play it.

## Searching for Tracks on a USB or Media Player

Select **Stations**.

Select a track.

**Note:** Select the cover art to view information about the current track.

**Note:** You can also browse by album, artist, audiobook, genre, playlist, podcast or track name.

## Repeating Tracks on a USB or Media Player



Select the repeat icon to repeat tracks.

**Note:** You can repeat one track or all tracks on an audio format USB or media player. You can repeat one track, all tracks or all tracks in one folder on a USB or media player.

**Note:** A small number one appears next to the repeat icon to indicate that a track is set to repeat. A small folder icon appears next to it to indicate that a folder is set to repeat

## Supported Devices

The system supports most USB and media players, including iOS and Android devices.

## Supported File Formats

The system supports the following file formats:

- MP3, MP4, WMA, WAV, AAC, AIFF, APE, DSD, and FLAC audio file formats.
- MP3, WMA, WAV, M4A, M4B, AAC, and FLAC file extensions.
- FAT, exFAT, and NTFS file systems.

## Audio File Metadata

The system organizes files on your USB or media player by metadata tags. Metadata tags contain information about the file. If the metadata tags for the files on your USB or media player contain no information, the system classifies them as unknown. The system can index up to 50000 tracks on a USB device or media player, and up to 10 devices.

## PHONE



**WARNING:** Driving while distracted can result in loss of vehicle control, crash and injury. We strongly recommend that you use extreme caution when using any device that may take your focus off the road. Your primary responsibility is the safe operation of your vehicle. We recommend against the use of any hand-held device while driving and encourage the use of voice-operated systems when possible. Make sure you are aware of all applicable local laws that may affect the use of electronic devices while driving.

Check the compatibility of your device on the local Ford website.

## Pairing Your Cell Phone for the First Time

Go to the settings menu on your cell phone and switch Bluetooth on.



Select the phone option on the feature bar.

1. Select **Pair phone**.

**Note:** A prompt alerts you to search for your vehicle on your cell phone.

2. Select your vehicle on your cell phone.

**Note:** A number appears on your cell phone and on the touchscreen.

3. Confirm that the number on your cell phone matches the number on the touchscreen.

**Note:** The touchscreen indicates that you have successfully paired your cell phone.

4. Download the phonebook from your cell phone when you are prompted.

**Note:** If you pair more than one cell phone, use the phone settings to specify the primary phone. You can change this setting at any time.

## Using Your Cell Phone

### Recent Call list

Display and select an entry from a list of previous calls.

### Contacts

Alphabetically sort your contacts. See **Settings** (page 325).

### Phone settings

Change ring tones, alerts or pair another phone.

### Do not disturb

Reject incoming calls and switch ring tones and alerts off.

### Phone Keypad

Directly dial a number.

## Using Text Messaging

Menu Item	Description
Hear it	Hear the text message.
View	View the text message.
Call	Call the sender.
Reply	Reply to the text message with a standard text message.

## Apple CarPlay

1. Connect your device to a USB port.
2. Follow the instructions on the touchscreen.

## Mute

Mute your cell phone microphone.

## Text Messaging

### Setting Text Message Notification

#### iOS

1. Go to the settings menu on your cell phone.
2. Select Bluetooth.
3. Select the information icon to the right of your vehicle.
4. Switch text message notification on.

#### Android

1. Go to the settings menu on your cell phone.
2. Select Bluetooth.
3. Select the profiles option.
4. Select the phone profile .
5. Switch text message notification on.

**Note:** Certain features of the system are not available when you are using Apple CarPlay.

### Switching Apple CarPlay Off



Select the settings option on the feature bar.

# SYNC™ 3

1. Select **Apple CarPlay preferences**.
2. Switch **Apple CarPlay** off.

## Android Auto

1. Connect your device to a USB port.
2. Follow the instructions on the touchscreen.

**Note:** You might need to enable Android Auto from the settings menu.

**Note:** Certain features of the system are not available when you are using Android Auto.

## Switching Android Auto Off



Select the settings option on the feature bar.

1. Select **Android Auto**.
2. Switch **Android Auto** off.

## NAVIGATION

**Note:** For more information, refer to the local Ford website.

### Setting a Destination

#### Destination Entry Menu

Item	Description
Search	Enter a destination address.
Previous destinations	Display and select from a list of previous destinations.
Home	Set your saved home address as your destination
Work	Set your saved place of work as your destination.
Favourites	Display and select from a list of favorite destinations.



Select the navigation option on the feature bar.

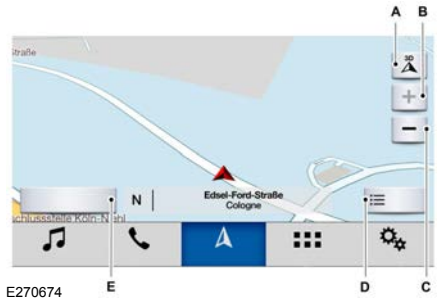

- A Map view menu.
- B Zoom in.
- C Zoom out.
- D Route guidance menu.
- E Destination entry menu.

## Setting a Destination Using the Text Entry Screen

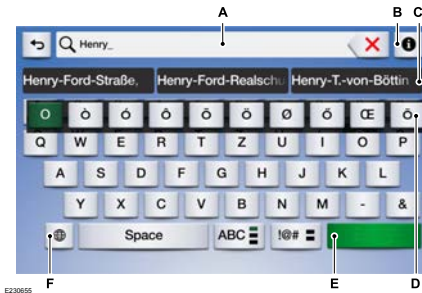

- A Text entry field.
- B Information icon.
- C Automatic suggestions based on the text you enter.
- D Extended keyboard.
- E Search.
- F Keyboard settings.

**Note:** Select one of the suggestions to copy the detail to the text entry field.

**You can search by entering all or part of the destination, such as: Address (Eg: 150 London Wall London or 54 Main St), POI category or name (Eg: Parking or Big Ben), Town or postcode (Eg: Paris or SS15 6EE), Junction (Eg: Palace St & Stafford Place), Latitude, longitude (Eg: 51.501476, -0.140634). Tips: The search is not case sensitive. To enter special or accented characters (Eg: ä or é) press and hold the corresponding letter on the keyboard. For additional search support, please refer to your regional Ford website.**

**Note:** Press the button in the top right-hand corner of the main map to display estimated time of arrival, remaining travel time or distance to destination.

## Setting a Destination Using the Map Screen

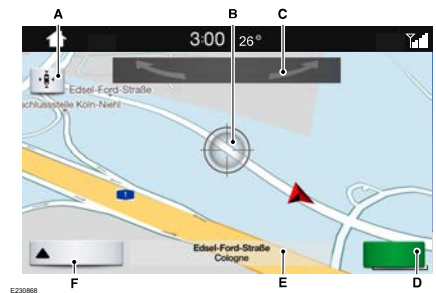

- A Re-center the map.
- B Selected location.
- C 3D map rotation. Swipe left or right.
- D Start route guidance.
- E Destination name.
- F Show feature bar.

Select the location on the map.

Select **Start** to begin route guidance.

## Changing the Format of the Map

Display the map in one of the following formats:

- A two-dimensional map with the direction you are traveling toward the top of the screen.
- A two-dimensional map with north toward the top of the screen.
- A three-dimensional map with the direction you are traveling toward the front.

## Zoom

Display more or less detail on the map.

**Note:** You can use pinch gestures to zoom in and out. Place two fingers on the screen and move them apart to zoom in. Place two fingers on the screen and bring them together to zoom out.

## Route Guidance

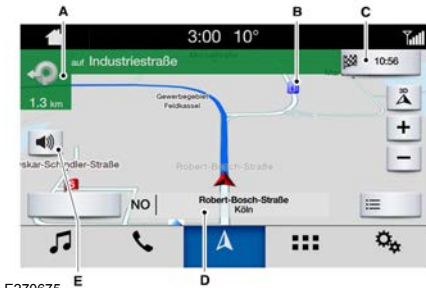

- C Estimated time of arrival, distance to destination or time to destination.
- D Current road.
- E Mute guidance prompts.

**Note:** To change guidance prompt volume, turn the volume control when a guidance prompt plays.

E270675

- A Turn indicator. Select to hear the last voice prompt.
- B Point of interest.

## Route Guidance Menu

Menu Item	Description
Screen view	Adjust your map preferences for when route guidance is active.
Full map	View a full screen map when route guidance is active.
Motorway exit info	View highway exit information for your current route.
Turn list	View the turn list for your current route. Select a road to avoid it.
Traffic list	View traffic nearby or on your current route. <sup>1</sup>
Navigation settings	Adjust navigation settings. See <b>Settings</b> (page 325).
Where am I?	View information about your current location.
Cancel route	Cancel route guidance.
Show route	View the entire current route on the map.
Re-route	View an alternative route compared to your current one.

# SYNC™ 3

Menu Item	Description
Edit waypoints	Change the order or remove waypoints.
Optimise order	The system determines the order of waypoints for you.
Start	Go to the next screen and start the new route.

<sup>1</sup> Reliant upon traffic message channel or live traffic.

## Adjusting the Guidance Prompt Volume

Turn the volume control when a guidance prompt plays to adjust the volume.

**Note:** If you have inadvertently adjusted the volume to zero, press the turn indicator button to play the last voice prompt and then adjust the volume to the desired level.

## Muting Guidance Prompts



Select the mute option on the screen to mute guidance prompts.

**Note:** The system mutes the next and all future guidance prompts.

## Adding Waypoints

You can add a waypoint to a navigation route as a destination along your route. You can add up to five waypoints.

1. Select the search option on the map.
2. Set a destination.
3. Select **Add waypoint**.
4. Select **Start**.

## Canceling Route Guidance



Select the route guidance menu option on the active guidance screen.

Select **Cancel route**.



E270676

**Note:** The route guidance menu option is always in the bottom right-hand corner of the main map.

## Live Traffic (If Equipped)

Live traffic provides near real-time traffic information to help you plan the fastest route to your destination. You must have an active subscription for Live Traffic.

# SYNC™ 3



E270955

- A Traffic congestion.
- B Traffic incident.
- C Urgent warning.

## Switching Live Traffic On

**Note:** Before you begin, enable the modem using the FordPass app. See **General Information** (page 308).



Select the settings option on the feature bar.

1. Select **SYNC Connect**.
2. Select **Connectivity settings**.
3. Switch **Connectivity features** on
4. Switch **Location** on.
5. Switch **Vehicle data & Remote ctrl** on.
6. Switch **Live Traffic** on.

## Michelin Travel Guide (If Equipped)

The Michelin travel guide is a service which provides additional information about certain places of interest, for example restaurants, hotels and tourist sites. Points of interest that have Michelin travel guide information display a button to show you

more information. Push the button to see the additional information. If you have paired your phone with the system, you can press the phone button to directly establish a call with the selected point of interest.

## Navigation Map Updates

HERE is the digital map provider for the navigation application. If you find map data errors, you may report them directly to HERE by going to [www.here.com](http://www.here.com). HERE evaluates all reported map errors and responds with the result of their investigation by e-mail.

## APPS

**Note:** For more information about available apps, refer to the regional Ford website.

When you start an app through the system for the first time, you could be asked to grant certain permissions. You can review and change the permissions that you have granted at any time when your vehicle is not moving. See **Settings** (page 325).

**Note:** We recommend that you check your data plan before using your apps through the system. Using them could result in additional charges.

**Note:** We recommend that you check the app provider's terms and conditions and privacy policy before using their app.

**Note:** Make sure that you have an active account for apps that you want to use through the system.

**Note:** Some apps will work with no setup. Others require you to configure some personal settings before you can use them.

## Using Apps on an iOS Device



Select the apps option on the feature bar.

# SYNC™ 3

1. Switch Apple CarPlay off. See **Phone** (page 318).
2. Connect your device to a USB port.
3. Start the apps on your device that you want to use through SYNC.

**Note:** *If you close the apps on your device, you will not be able to use them through the system.*

4. Select **Find mobile apps**.

**Note:** *The system searches and connects to compatible apps that are running on your device.*

5. Select the app that you want to use on the touchscreen.

## Using Apps on an Android Device



Select the apps option on the feature bar.

1. Switch Android Auto off. See **Phone** (page 318).
2. Pair your device. See **Phone** (page 318).
3. Start the apps on your device that you want to use through SYNC.

**Note:** *If you close the apps on your device, you will not be able to use them through the system.*

4. Select **Find mobile apps**.

**Note:** *The system searches and connects to compatible apps that are running on your device.*

5. Select the app that you want to use on the touchscreen.

## SETTINGS

### General

Item	Description
Language	Set the language.
Measure unit	Set the distance unit.
Temperature unit	Set the temperature unit.
Touchscreen beep	Switch touchscreen tones on and off.
Automatic system updates	Switch automatic updates on and off.
About SYNC	View information about the system and software.
Software licences	View information about the software license.
Master reset	Reset all settings to factory levels. <sup>1</sup>

<sup>1</sup> This resets all settings and deletes your personal data.

# SYNC™ 3

## Display

Item	Description
Brightness	Adjust the display brightness. <sup>1</sup>
Mode	Set a light background, a dark background or have the system adjust the background based on how dark it is.
Display off	Switch the display off. <sup>2</sup>
Auto dim	Have the system adjust the display brightness based on how dark it is.

<sup>1</sup> This does not change the brightness that you set through the information display.

<sup>2</sup> Touch the screen to switch the display back on.

## Sound

Item	Description
Reset all	Reset all sound settings to factory levels.
Treble	Adjust treble frequency sounds.
Mid-range	Adjust mid-range frequency sounds.
Bass	Adjust bass frequency sounds.
Balance/Fade	Adjust the sound ratio from side to side and front to rear.
Adaptive volume	Adjust the amount that the volume increases as your vehicle speed increases.
DSP occupancy	Optimize sound for certain seating positions.
Sound mode	Switch stereo and surround sound on and off.

# SYNC™ 3

## Media Player

Item	Description
Podcast speed	Adjust the playback speed of podcasts on some iOS devices.
Audiobook playback speed	Adjust the playback speed of audiobooks on some iOS devices.
Cover Art priority	Displays the cover art from the files on your device. If the files on your device do not contain cover art, the system displays Gracenote cover art.
Gracenote® management	Switch the provision of metadata from Gracenote on and off.
Gracenote® database info	View information about Gracenote.
Device information	View information about your media player software license.
Reset media index	Delete the metadata that the system holds about the files on your device to allow re-indexing.

## Clock

Item	Submenu Item
Clock format	Set how time displays.
Auto time zone update	Set the clock to adjust to time zone changes.
Reset clock to GPS time	Set the clock to adjust GPS satellite changes.

The system automatically saves any updates you make to these settings.

## Bluetooth

Item	Description
Bluetooth	Switch Bluetooth on and off.

# SYNC™ 3

## Phone

Item	Description
View Devices	Manage your devices.
Add device	Add a device.
Connect	Connect a device.
Disconnect	Disconnect a device.
Device information	View information about your device.
Make favourite	Select a preferred device.
Delete	Delete a device.
Manage contacts	Manage your phonebook and contacts.
Automatic contact download	Switch automatic phonebook download on.
Sort by:	Set your contacts to display alphabetically by forename or by surname.
Re-download contacts	Manually download your phonebook.
Delete contacts	Delete your phonebook from the system.
Phone Ringtone selection	Manage device tones.
No ringtone	Mute the ring tone of your cell phone.
Use phone ringtone	View and select the ring tone for incoming calls. You can select the ring tone on your phone or one of the system ring tones.
Text messaging	Switch text messaging on and off.
No tone (silence)	Switch text message notification tones on and off.
Voice read out	Switch text message voice notification on and off.
Roaming warning	Switch roaming notification on and off.
Low battery notification	Switch low battery notification on and off.

## Emergency Assistance

Item	Description
Emergency Assistance	Switch Emergency Assistance on and off.
Set emergency contacts	Set emergency contacts from your phonebook.

## Radio

Item	Description
Radio text	View information about the current radio broadcast.
Autostore presets (AST)	Refresh the six strongest FM radio stations in your current location to the preset bank where the current radio station is stored.

## Navigation System (If Equipped)

### Map

Item	Description
Map preferences	Adjust your map preferences.
3-D city model	Display three-dimensional buildings on the map.
Breadcrumbs	Display white dots on the map to represent your previous route.
POI icons	Display point of interest icons on the map.
Select POIs	Select which point of interest categories display on the map.

### Route Guidance

Item	Description
Route preferences	Adjust your route preferences.
Preferred route	Select the shortest, fastest or most eco friendly route.
Always use ___ route	Bypass route selection in destination programming. The system only calculates one route based on your preferred route setting.

# SYNC™ 3

Item	Description
Automatic find parking	The system searches for and displays available parking locations as you approach your destination.
Eco time penalty	Select a level of cost for the calculated eco friendly route. The higher the setting, the longer the system allows for the route.
Dynamic route guidance	Switch whether the system considers traffic information when planning a route on or off. <sup>1</sup>
Navigation preferences	Adjust your navigation preferences.
Guidance prompts	Select voice and tones, only voice or only tones.
Hazard spot warning	Select visual and tones or only visual. <sup>2</sup>

<sup>1</sup> Reliant upon traffic message channel or live traffic.

<sup>2</sup> Not available in all countries.

## Apps

Item	Description
Mobile apps settings	Enable or disable the use of mobile apps on the system. Disabling mobile apps in the settings menu disables automatic updates and the use of mobile apps on the system.
Update mobile apps	Provides information on the current state of available app updates.
All apps	Grant or deny permissions to all apps at once.

# SYNC™ 3

## Modem (If Equipped)

### Wi-Fi Hotspot

Item	Description
Vehicle Hotspot	Switch the vehicle Wi-Fi hotspot on or off.
Settings	View and edit Wi-Fi hotspot settings such as the SSID and password.
Data Usage	View the vehicle Wi-Fi hotspot plan and data usage.
Manage Devices	Manage the devices connected to the vehicle Wi-Fi hotspot.
Manage My Account	Manage your account or purchase a plan.

### Connectivity Settings

Item	Description
Connectivity Features	Enable or disable the modem.
Send Vehicle Data	Send or stop sending vehicle data to Ford.
Location	Send or stop sending location data to Ford.
Vehicle Data & Remote Ctrl	Send or stop sending vehicle data to Ford.
FordPass Connect Live Traffic	Switch live traffic on or off.

### Wi-Fi

Item	Description
System Wi-Fi	Adjust your Wi-Fi preferences.
View available networks	Select from the list of available Wi-Fi networks.
Wi-Fi availability notification	Select to switch notifications on and off.

## Vehicle Settings (If Equipped)

### Camera

Item	Description
Camera settings	Adjust the rear camera preferences.
Rear camera delay	You can enable or disable this option using the slider. When this option is on, the rear view camera display is shown for a short time after you shift the vehicle into drive.
Active Park Assist	Allows you to switch the park aid feature on and off from the rear view camera screen.

### Voice Recognition

Item	Description
Advanced mode	Enable this option to remove additional voice prompts and confirmations.
Phone confirmation	Enable this option to have the system confirm a contacts name with you before making a call.
Voice command list	Enable this option to have the system display a list of available voice commands when the voice button is pressed.

### Valet Mode (If Equipped)

Valet mode allows you to lock the system. No information is accessible until the system is unlocked with the correct PIN.

When you select valet mode a pop up appears informing you that a four digit code must be entered to enable and disable valet mode. You can use any PIN you chose but you must use the same PIN to disable valet mode. The system asks you to input the code.

**Note:** *If the system locks, and you need to reset the PIN, contact an authorized dealer.*

To enable valet mode, enter your chosen PIN. The system then asks to confirm your PIN by reentering it. The system then locks.

To unlock the system, enter the same pin number. The system reconnects to your phone and all of your options are available again.

## SYNC™ 3 TROUBLESHOOTING

### Voice Recognition

Symptom	Possible Cause and Resolution
<p>The system does not understand what I am saying.</p>	<ul style="list-style-type: none"> <li>– You are using the wrong voice commands.                             <ul style="list-style-type: none"> <li>• See <b>Using Voice Recognition</b> (page 311).</li> <li>• For a complete list of voice commands, refer to the local Ford website.</li> </ul> </li> <li>– You are speaking too soon.                             <ul style="list-style-type: none"> <li>• Wait for the voice prompt before you speak.</li> </ul> </li> </ul>
<p>The system does not understand the name of a track or artist.</p>	<ul style="list-style-type: none"> <li>– Device limitation. Bluetooth does not support voice commands.                             <ul style="list-style-type: none"> <li>• Connect your device to a USB port.</li> <li>• If you have an iOS device, press and hold the voice control button on the steering wheel to use Siri to play specific tracks.</li> </ul> </li> <li>– You are using the wrong voice commands.                             <ul style="list-style-type: none"> <li>• See <b>Using Voice Recognition</b> (page 311).</li> <li>• For a complete list of voice commands, refer to the local Ford website.</li> </ul> </li> <li>– You are not saying the name exactly as it appears on your device.                             <ul style="list-style-type: none"> <li>• Say the name of the track or artist exactly as it appears on your device. Spell out any abbreviations in the name.</li> </ul> <p>The song or artist name may have some special characters that are not being recognized by the system.</p> </li> <li>– The name contains special characters, for example *, - or +.                             <ul style="list-style-type: none"> <li>• Rename the files on your device or use the touchscreen to select and play the track.</li> </ul> </li> </ul>

# SYNC™ 3

Symptom	Possible Cause and Resolution
The system does not understand the name of a contact in the phonebook on my device and calls the wrong contact.	<ul style="list-style-type: none"> <li>– You are not saying the name exactly as it appears on your device.               <ul style="list-style-type: none"> <li>• Say the first and last name of the contact exactly as it appears on your device. Spell out any abbreviations in the name.</li> </ul> </li> <li>– The name contains special characters, for example *, - or +.               <ul style="list-style-type: none"> <li>• Rename the contact on your device or use the touchscreen to select and call the contact.</li> </ul> </li> </ul>
The system does not understand foreign names of contacts in the phonebook on my device.	<ul style="list-style-type: none"> <li>– You are not saying the name exactly as it appears on your device.               <ul style="list-style-type: none"> <li>• Say the first and last name of the contact exactly as it appears on your device. The system applies phonetic pronunciation rules of the selected language to the names of contacts in the phonebook on your device. Select the name of the contact on the touchscreen and use the Hear it option to get an idea of how the system expects you to pronounce it.</li> </ul> </li> </ul>
The system voice prompts and the pronunciation of some words does not seem to be very accurate.	<ul style="list-style-type: none"> <li>– Device limitation.               <ul style="list-style-type: none"> <li>• The system uses text-to-speech technology and uses a synthetically generated voice rather than pre-recorded human voice.</li> </ul> </li> </ul>

## USB and Bluetooth Audio

Symptom	Possible Cause and Resolution
I cannot connect my device.	<ul style="list-style-type: none"> <li>– Device malfunction.               <ul style="list-style-type: none"> <li>• Disconnect your device. Switch your device off, reset it and try again.</li> </ul> </li> <li>– Cable connection issue.               <ul style="list-style-type: none"> <li>• Correctly connect the cable to your device and the vehicle USB port.</li> </ul> </li> <li>– Incompatible cable.               <ul style="list-style-type: none"> <li>• Use the cable recommended by the manufacturer of your device.</li> </ul> </li> </ul>

# SYNC™ 3

Symptom	Possible Cause and Resolution
	<ul style="list-style-type: none"> <li>– Incorrect device settings.               <ul style="list-style-type: none"> <li>• Make sure that your device does not have an auto-install program or active security settings.</li> <li>• Check that your device is not set only to charge.</li> </ul> </li> <li>– Device lock screen enabled.               <ul style="list-style-type: none"> <li>• Unlock your device before connecting it.</li> </ul> </li> </ul>
The system does not recognize my device.	<ul style="list-style-type: none"> <li>– Device limitation.               <ul style="list-style-type: none"> <li>• Do not leave your device in your vehicle during very hot or very cold weather conditions.</li> </ul> </li> </ul>
The system does not understand the name of a track or artist.	<ul style="list-style-type: none"> <li>– Device limitation. Bluetooth does not support voice commands.               <ul style="list-style-type: none"> <li>• Connect your device to a USB port.</li> <li>• If you have an iOS device, press and hold the voice control button on the steering wheel to use Siri to play specific tracks.</li> </ul> </li> </ul>
I cannot stream audio from my Bluetooth device.	<ul style="list-style-type: none"> <li>– Incompatible device.               <ul style="list-style-type: none"> <li>• Check the compatibility of your device on the local Ford website.</li> </ul> </li> <li>– Device not connected.               <ul style="list-style-type: none"> <li>• Pair your device. See <b>Phone</b> (page 318).</li> </ul> </li> <li>– Media player not running.               <ul style="list-style-type: none"> <li>• Start the media player on your device.</li> </ul> </li> </ul>
The system does not recognize the music on my device.	<ul style="list-style-type: none"> <li>– Missing or incorrect audio file metadata, for example artist, song title, album or genre.               <ul style="list-style-type: none"> <li>• Repair the files on your device.</li> </ul> </li> <li>– Corrupt files.               <ul style="list-style-type: none"> <li>• Repair the files on your device.</li> </ul> </li> <li>– Copyright protected files.               <ul style="list-style-type: none"> <li>• Use a device that contains files that are not copyright protected.</li> </ul> </li> <li>– Unsupported file format.               <ul style="list-style-type: none"> <li>• Repair or convert the files to a supported format. See <b>Entertainment</b> (page 316).</li> </ul> </li> </ul>

# SYNC™ 3

Symptom	Possible Cause and Resolution
	<ul style="list-style-type: none"> <li>– Device indexing required.               <ul style="list-style-type: none"> <li>• Re-index your device. See <b>Settings</b> (page 325).</li> </ul> </li> <li>– Device lock screen enabled.               <ul style="list-style-type: none"> <li>• Unlock your device before connecting it.</li> </ul> </li> </ul>
Sometimes I cannot hear a track playing on my device.	<ul style="list-style-type: none"> <li>– Device malfunction.               <ul style="list-style-type: none"> <li>• Disconnect your device. Switch your device off, reset it and try again.</li> </ul> </li> </ul>
When I disconnect my iOS device the audio volume is set to maximum.	<ul style="list-style-type: none"> <li>– Device limitation.               <ul style="list-style-type: none"> <li>• Turn the volume down on your device</li> </ul> </li> </ul>
The system does not play the tracks on my USB drive in the correct order.	<p>If the system does not play the tracks on your USB device in the correct order, the following information could help:</p> <ul style="list-style-type: none"> <li>– If you are selecting USB as the audio source when the system is still indexing, SYNC plays tracks sorted alphabetically by file name in the root directory.</li> <li>– If you are selecting USB as the audio source after the system has finished indexing, SYNC plays all tracks sorted alphabetically by the title in the ID3 tag regardless of where they are located. SYNC uses the file name if the title in the ID3 Tag does not exist.</li> <li>– If you are selecting the option to play all tracks from the browsing menu, SYNC plays all tracks sorted alphabetically by the title in the ID3 tag regardless of where they are located. SYNC uses the file name if the title in the ID3 Tag does not exist.</li> <li>– If you are selecting a track when using the explore device option, SYNC plays tracks sorted alphabetically by file name in the folder you have selected. SYNC then plays all tracks in any subfolders in the folder you have selected.</li> </ul>

## Phone

Symptom	Possible Cause and Resolution
During a call, I can hear excessive background noise.	<ul style="list-style-type: none"> <li>– Incorrect cell phone settings.                             <ul style="list-style-type: none"> <li>• Check and adjust the audio settings on your cell phone. Refer to your cell phone's user manual.</li> </ul> </li> </ul>
During a call, I can hear the other person but they cannot hear me.	<ul style="list-style-type: none"> <li>– Cell phone malfunction.                             <ul style="list-style-type: none"> <li>• Switch your cell phone off, reset it and try again.</li> </ul> </li> <li>– Cell phone microphone muted.                             <ul style="list-style-type: none"> <li>• Unmute your cell phone microphone.</li> </ul> </li> </ul>
During a call, I cannot hear the other person and they cannot hear me.	<ul style="list-style-type: none"> <li>– System restart required.                             <ul style="list-style-type: none"> <li>• Restart the system. Switch the ignition off and open the door. Close the door and lock the vehicle. Wait until the touchscreen is off and any illuminated USB ports are not illuminated. Unlock the vehicle, switch the ignition on and try again.</li> </ul> </li> </ul>
I cannot download phone-book.	<ul style="list-style-type: none"> <li>– Incompatible cell phone.                             <ul style="list-style-type: none"> <li>• Check the compatibility of your cell phone on the local Ford website.</li> </ul> </li> <li>– Incorrect cell phone settings.                             <ul style="list-style-type: none"> <li>• Allow the system to retrieve contacts from your cell phone. Refer to your cell phone's user manual.</li> </ul> </li> <li>– Incorrect system settings.                             <ul style="list-style-type: none"> <li>• Switch automatic phonebook download on. See <b>Settings</b> (page 325).</li> </ul> </li> <li>– Cell phone malfunction.                             <ul style="list-style-type: none"> <li>• Switch your cell phone off, reset it and try again.</li> </ul> </li> </ul>
A message displays suggesting that my phone-book has downloaded but it is empty or it has missing contacts.	<ul style="list-style-type: none"> <li>– Incorrect cell phone settings.                             <ul style="list-style-type: none"> <li>• Allow the system to retrieve contacts from your cell phone. Refer to your cell phone's user manual.</li> <li>• Check the location of the missing contacts on your cell phone. If they are stored on the SIM card, move them to the cell phone memory.</li> </ul> </li> <li>– Incorrect system settings.                             <ul style="list-style-type: none"> <li>• Switch automatic phonebook download on. See <b>Settings</b> (page 325).</li> </ul> </li> </ul>

# SYNC™ 3

Symptom	Possible Cause and Resolution
I cannot connect my cell phone.	<ul style="list-style-type: none"> <li>– Incompatible cell phone.               <ul style="list-style-type: none"> <li>• Check the compatibility of your cell phone on the local Ford website.</li> </ul> </li> <li>– Cell phone malfunction.               <ul style="list-style-type: none"> <li>• Switch your cell phone off, reset it and try again.</li> <li>• Install the latest cell phone firmware.</li> <li>• Delete your device from system and delete SYNC from your device and try again.</li> <li>• Switch automatic phonebook download off. See <b>Settings</b> (page 325).</li> </ul> </li> </ul>
Text messaging does not work.	<ul style="list-style-type: none"> <li>– Incompatible cell phone.               <ul style="list-style-type: none"> <li>• Check the compatibility of your cell phone on the local Ford website.</li> </ul> </li> <li>– Cell phone malfunction.               <ul style="list-style-type: none"> <li>• Switch your cell phone off, reset it and try again.</li> </ul> </li> </ul>
I cannot hear text messages.	<ul style="list-style-type: none"> <li>– Incompatible cell phone.               <ul style="list-style-type: none"> <li>• Check the compatibility of your cell phone on the local Ford website.</li> </ul> </li> </ul>

## Navigation (If Equipped)

Symptom	Possible Cause and Resolution
I cannot enter a street name when I am abroad.	<ul style="list-style-type: none"> <li>– Incorrect entry method.               <ul style="list-style-type: none"> <li>• Enter the street name without the country.</li> </ul> </li> </ul>
The system does not recognize coordinates.	<ul style="list-style-type: none"> <li>– You are using the wrong coordinates format.               <ul style="list-style-type: none"> <li>• Use the format is ##. #####, ##. ##### (for N/S, E/W). Add a minus before coordinates if the direction is West and keep a positive value if the direction is East, for example 12.5412 means East and -12.5412 means West.</li> </ul> </li> </ul>

# SYNC™ 3

## Apps

Symptom	Possible Cause and Resolution
The system cannot find any apps.	<ul style="list-style-type: none"> <li>– Incompatible device.               <ul style="list-style-type: none"> <li>• You will need an Android device with OS 2.3 or higher or an iOS 3GS device with iOS 5.0 or higher. Pair and connect your Android device to find AppLink compatible apps. Connect your iOS device to a USB port to find AppLink compatible apps.</li> </ul> </li> </ul>
I have a compatible device and it is correctly connected but the system still cannot find any apps.	<ul style="list-style-type: none"> <li>– AppLink compatible apps not installed on your device.               <ul style="list-style-type: none"> <li>• Download and install the latest version of the app.</li> </ul> </li> <li>– AppLink compatible apps not running on your device.               <ul style="list-style-type: none"> <li>• Start the apps to allow the system to find them and make sure you sign in to any apps if required.</li> </ul> </li> <li>– Incorrect app settings.               <ul style="list-style-type: none"> <li>• Check and adjust the app settings on your device and allow SYNC to access the app if required.</li> </ul> </li> </ul>
I have a compatible device, it is correctly connected and my apps are running but the system still cannot find any apps.	<ul style="list-style-type: none"> <li>– Apps failed to fully close.               <ul style="list-style-type: none"> <li>• Restart the apps and try again.</li> <li>• If you have an Android device with apps that have an exit or quit option, use this and then restart the apps. Alternatively, use the force stop option in the settings menu on your device.</li> <li>• If you have an iOS device with iOS 7.0 or higher, tap the home button on your device twice and then swipe the app upward to close it.</li> </ul> </li> </ul>
I have an Android device that is correctly connected, I have restarted my apps and they are running but the system still cannot find them.	<ul style="list-style-type: none"> <li>– An issue on some older versions of the Android operating system could result in apps not being found.               <ul style="list-style-type: none"> <li>• Switch Bluetooth off and on again to force the system to reconnect to your device.</li> </ul> </li> </ul>

## SYNC™ 3

<b>Symptom</b>	<b>Possible Cause and Resolution</b>
I have an iOS device that is correctly connected, I have restarted my apps and they are running but the system still cannot find them.	<ul style="list-style-type: none"><li>- Cable connection issue.<ul style="list-style-type: none"><li>• Disconnect the cable from your device, wait for a moment and then connect it again to force the system to reconnect to your device.</li></ul></li></ul>
I have an Android device running a media app which the system has found but I cannot hear the sound or the sound is very quiet.	<ul style="list-style-type: none"><li>- Device volume is low.<ul style="list-style-type: none"><li>• Turn the volume up on your device.</li></ul></li></ul>
I have an Android device running a number of compatible apps but the system cannot find all of them.	<ul style="list-style-type: none"><li>- Device limitation. Some Android devices have a limited number of Bluetooth ports that apps can use to connect. If you have more apps running on your device than the number of available Bluetooth ports, the system cannot find all of them.<ul style="list-style-type: none"><li>• Close some of the apps to allow the system to find those that you want to use.</li></ul></li></ul>

## Wi-Fi Connectivity

Symptom	Possible Cause and Resolution
I cannot connect to a Wi-Fi network.	<ul style="list-style-type: none"> <li>– Password error.               <ul style="list-style-type: none"> <li>• Enter the correct network password.</li> </ul> </li> <li>– Weak network signal.               <ul style="list-style-type: none"> <li>• Move your vehicle closer to the Wi-Fi hotspot or to a place where the network signal is not obstructed.</li> </ul> </li> <li>– Multiple access points in range with the same SSID.               <ul style="list-style-type: none"> <li>• Use a unique name for your SSID,. Do not use the default name unless it contains a unique identifier, for example as part of the MAC address.</li> </ul> </li> </ul>
The Wi-Fi connection disconnects after successful connection.	<ul style="list-style-type: none"> <li>– Weak network signal.               <ul style="list-style-type: none"> <li>• Move your vehicle closer to the Wi-Fi hotspot or to a place where the network signal is not obstructed.</li> </ul> </li> </ul>
I am close to a Wi-Fi hotspot but the network signal strength is weak.	<ul style="list-style-type: none"> <li>– Obstructed network signal.               <ul style="list-style-type: none"> <li>• If your vehicle has a heated windshield, position your vehicle so that the windshield is not facing the Wi-Fi hotspot.</li> <li>• If your vehicle has metallic tinting on the windows but not on the windshield, position your vehicle so that the windshield is facing the Wi-Fi hotspot or open the windows that are facing the hotspot.</li> <li>• If your vehicle has metallic tinting on the windows and the windshield, open the windows that are facing the hotspot.</li> <li>• If your vehicle is in a garage and you have the garage door closed, open the garage door.</li> </ul> </li> </ul>
I cannot see a network in the list of available networks that I expect to see.	<ul style="list-style-type: none"> <li>– Hidden network.               <ul style="list-style-type: none"> <li>• Make the network visible and try again.</li> </ul> </li> </ul>

# SYNC™ 3

Symptom	Possible Cause and Resolution
I cannot see SYNC when I search for Wi-Fi networks on my cell phone or other device.	<ul style="list-style-type: none"><li>– System limitation.<ul style="list-style-type: none"><li>• SYNC does not provide a Wi-Fi hotspot at this time.</li></ul></li></ul>
Software downloads take too long.	<ul style="list-style-type: none"><li>– Weak network signal<ul style="list-style-type: none"><li>• Move your vehicle closer to the Wi-Fi hotspot or to a place where the network signal is not obstructed.</li></ul></li><li>– Wi-Fi hotspot in high demand or has a slow Internet connection.<ul style="list-style-type: none"><li>• Use an more reliable Wi-Fi hotspot.</li></ul></li></ul>
The system seems to connect to a Wi-Fi network and the signal strength is excellent but the software does not update.	<ul style="list-style-type: none"><li>– No software update available.</li><li>– Wi-Fi network requires a subscription or acceptance of terms and conditions.<ul style="list-style-type: none"><li>• Test the connection using another device. If the network requires a subscription or acceptance of terms and conditions, contact the network service provider.</li></ul></li></ul>

## Resetting the System

1. Simultaneously press and hold the seek up and the audio unit power buttons until the screen goes black.
2. Wait three minutes to allow the system to complete the reset.
3. Press the audio unit power button to switch the system on.

**Note:** You can reset the system to restore functionality that has stopped working. The system reset is designed to restore functionality and not delete any data that you have stored.

## Additional Information and Assistance

For additional information and assistance, we recommend that you contact an authorized dealer or refer to the local Ford website.

# Appendices

## ELECTROMAGNETIC COMPATIBILITY



**WARNING:** Do not place objects or mount equipment on or near the airbag cover, on the side of the seatbacks (of the front seats), or in front seat areas that may come into contact with a deploying airbag. Failure to follow these instructions may increase the risk of personal injury in the event of a crash.



**WARNING:** Do not fasten antenna cables to original vehicle wiring, fuel pipes and brake pipes.



**WARNING:** Keep antenna and power cables at least 10 cm (4 in) from any electronic modules and airbags.

**Note:** We test and certify your vehicle to meet electromagnetic compatibility legislation (UNECE Regulation 10 or other applicable local requirements). It is your responsibility to make sure that any equipment an authorized dealer installs on your vehicle complies with applicable local legislation and other requirements.

**Note:** Any radio frequency transmitter equipment in your vehicle (such as cellular telephones and amateur radio transmitters) must keep to the parameters in the following table. We do not provide special provisions or conditions for installations or use.

### Car

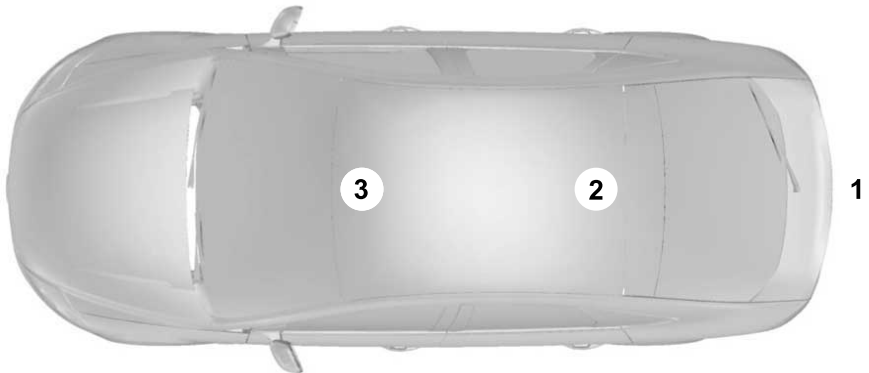

E239120

# Appendices

---

## Van



E239122

## Truck

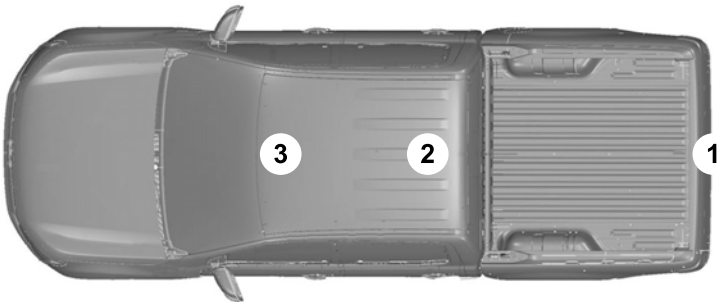

E239121

# Appendices

Frequency Band MHz	Maximum output power Watt (Peak RMS)	Antenna Positions
1-30	50	1
50-54	50	2, 3
68-88	50	2, 3
142-176	50	2, 3
380-512	50	2, 3
806-870	10	2, 3

**Note:** After the installation of radio frequency transmitters, check for disturbances from and to all electrical equipment in your vehicle, both in the standby and transmit modes.

Check all electrical equipment:

- With the ignition ON.
- With the engine running.
- During a road test at various speeds.

Check that electromagnetic fields generated inside your vehicle cabin by the transmitter installed do not exceed applicable human exposure requirements.

## END USER LICENSE AGREEMENT

### VEHICLE SOFTWARE END USER LICENSE AGREEMENT (EULA)

- You ("You" or "Your" as applicable) have acquired a vehicle having several devices, including SYNC ® and various control modules, ("DEVICES") that include software licensed or owned by Ford Motor Company and its affiliates ("FORD MOTOR COMPANY"). Those software products of FORD MOTOR COMPANY origin, as well as associated media, printed materials, and "online" or electronic documentation ("SOFTWARE") are protected by international intellectual property laws and treaties. The SOFTWARE is licensed, not sold. All rights reserved.
- The SOFTWARE may interface with and/or communicate with, or may be later upgraded to interface with and/or communicate with additional software and/or systems provided by FORD MOTOR COMPANY.

# Appendices

---

**IF YOU DO NOT AGREE TO THIS END USER LICENSE AGREEMENT ("EULA") DO NOT USE THE DEVICES OR COPY THE SOFTWARE. ANY USE OF THE SOFTWARE, INCLUDING BUT NOT LIMITED TO USE ON THE DEVICES, WILL CONSTITUTE YOUR AGREEMENT TO THIS EULA (OR RATIFICATION OF ANY PREVIOUS CONSENT).**

**GRANT OF SOFTWARE LICENSE:** This EULA grants you the following license:

- You may use the SOFTWARE as installed on the DEVICES and as otherwise interfacing with systems and/or services provide by or through FORD MOTOR COMPANY or its third party software and service providers.

## **Description of Other Rights and Limitations**

- **Speech Recognition:** If the SOFTWARE includes speech recognition component(s), you should understand that speech recognition is an inherently statistical process and that recognition errors are inherent in the process. Neither FORD MOTOR

COMPANY nor its suppliers shall be liable for any damages arising out of errors in the speech recognition process. It is your responsibility to monitor any speech recognition functions included in the system.

- **Limitations on Reverse Engineering, Decompilation and Disassembly:**

You may not reverse engineer, decompile, translate, disassemble or attempt to discover any source code or underlying ideas or algorithms of the SOFTWARE nor permit others to reverse engineer, decompile or disassemble the SOFTWARE, except and only to the extent that such activity is expressly permitted by applicable law notwithstanding this limitation or to the extent as may be permitted by the licensing terms governing use of any open source components included with the SOFTWARE.

- **Limitations on Distributing, Copying, Modifying and Creating Derivative Works:**

You may not distribute, copy, make modifications to or create derivative works based on the SOFTWARE, except and only to the extent that such activity is expressly permitted by applicable law notwithstanding this limitation or to the extent as may be permitted by the licensing terms governing use of any open source components included with the SOFTWARE.

- **Single EULA:** The end user documentation for the DEVICES and related systems and services may contain multiple EULAs, such as multiple translations and/or multiple media versions (e.g., in the user documentation and in the software). Even if you receive multiple EULAs, you are licensed to use only one (1) copy of the SOFTWARE.

# Appendices

---

- **SOFTWARE Transfer:** You may permanently transfer your rights under this EULA only as part of a sale or transfer of the DEVICES, provided you retain no copies, you transfer all of the SOFTWARE (including all component parts, the media and printed materials, any upgrades, and, if applicable, the Certificate(s) of Authenticity), and the recipient agrees to the terms of this EULA. If the SOFTWARE is an upgrade, any transfer must include all prior versions of the SOFTWARE.
- **Termination:** Without prejudice to any other rights, FORD MOTOR COMPANY may terminate this EULA if you fail to comply with the terms and conditions of this EULA.
- **Internet-Based Services Components:** The SOFTWARE may contain components that enable and facilitate the use of certain Internet-based services. You acknowledge and agree that FORD MOTOR COMPANY, third party software and service suppliers, its affiliates and/or its designated agent may automatically check the version of the SOFTWARE and/or its components that you are utilizing and may provide upgrades or supplements to the SOFTWARE that may be automatically downloaded to your DEVICES.
- **Additional Software/Services:** The SOFTWARE may permit FORD MOTOR COMPANY, third party software and service suppliers, its affiliates and/or its designated agent to provide or make available to you SOFTWARE updates, supplements, add-on components, or Internet-based services components of the SOFTWARE after the date you obtain your initial copy of the SOFTWARE ("Supplemental Components".) SOFTWARE updates may cause you to incur additional charges from your wireless service provider. If FORD MOTOR COMPANY or third party software and services suppliers provide or make available to you Supplemental Components and no other EULA terms are provided along with the Supplemental Components, then the terms of this EULA shall apply. FORD MOTOR COMPANY, its affiliates and/or its designated agent reserve the right to discontinue without liability any Internet-based services provided to you or made available to you through the use of the SOFTWARE.
- **Links to Third Party Sites:** The SOFTWARE may provide you with the ability to link to third party sites. The third party sites are not under the control of FORD MOTOR COMPANY, its affiliates and/or its designated agent. Neither FORD MOTOR COMPANY nor its affiliates nor its designated agent are responsible for (i) the contents of any third party sites, any links contained in third party sites, or any changes or updates to third party sites, or (ii) webcasting or any other form of transmission received from any third party sites. If the SOFTWARE provides links to third party sites, those links are provided to you only as a convenience, and the inclusion of any link does not imply an endorsement of the third party site by FORD MOTOR COMPANY, its affiliates and/or its designated agent.
- **Obligation to Drive Responsibly:** You recognize your obligation to drive responsibly and keep attention on the road. You will read and abide with the DEVICES operating instructions particularly as they pertain to safety and you agree to assume any risk associated with the use of the DEVICES.

# Appendices

---

## **UPGRADES AND RECOVERY MEDIA:**

If the SOFTWARE is provided by FORD MOTOR COMPANY separate from the DEVICES on media such as a ROM chip, CD ROM disk(s) or via web download or other means, and is labeled "For Upgrade Purposes Only" or "For Recovery Purposes Only" you may install one (1) copy of such SOFTWARE onto the DEVICES as a replacement copy for the existing SOFTWARE, and use it in accordance with this EULA, including any additional EULA terms accompanying the upgrade SOFTWARE.

## **INTELLECTUAL PROPERTY RIGHTS:**

All title and intellectual property rights in and to the SOFTWARE (including but not limited to any images, photographs, animations, video, audio, music, text and "applets" incorporated into the SOFTWARE), the accompanying printed materials, and any copies of the SOFTWARE, are owned by FORD MOTOR COMPANY, or its affiliates or suppliers. The SOFTWARE is licensed, not sold. You may not copy the printed materials accompanying the SOFTWARE. All title and intellectual property rights in and to the content which may be accessed through use of the SOFTWARE is the property of the respective content owner and may be protected by applicable copyright or other intellectual property laws and treaties. This EULA grants you no rights to use such content outside its intended use. All rights not specifically granted under this EULA are reserved by FORD MOTOR COMPANY, its affiliates, and third party software and service providers and suppliers. Use of any on-line services which may be accessed through the SOFTWARE may be governed by the respective terms of use relating to such services. If this SOFTWARE contains documentation that is provided only in electronic form, you may print one copy of such electronic documentation.

**EXPORT RESTRICTIONS:** You acknowledge that the SOFTWARE is subject to U.S. and European Union export jurisdiction. You agree to comply with all applicable international and national laws that apply to the SOFTWARE, including the U.S. Export Administration Regulations, as well as end-user, end-use and destination restrictions issued by U.S. and other governments.

**TRADEMARKS:** This EULA does not grant you any rights in connection with any trademarks or service marks of FORD MOTOR COMPANY, its affiliates, and third party software and service providers.

**PRODUCT SUPPORT:** Please refer to FORD MOTOR COMPANY instructions provided in the documentation for the DEVICES product support, such as the vehicle owner guide.

Should you have any questions concerning this EULA, or if you desire to contact FORD MOTOR COMPANY for any other reason, please refer to the address provided in the documentation for the DEVICES.

## **No Liability for Certain Damages:**

EXCEPT AS PROHIBITED BY LAW, FORD MOTOR COMPANY, ANY THIRD PARTY SOFTWARE OR SERVICES SUPPLIERS, AND THEIR AFFILIATES SHALL HAVE NO LIABILITY FOR ANY INDIRECT, SPECIAL, CONSEQUENTIAL OR INCIDENTAL DAMAGES ARISING FROM OR IN CONNECTION WITH THE USE OR PERFORMANCE OF THE SOFTWARE. THIS LIMITATION SHALL APPLY EVEN IF ANY REMEDY FAILS OF ITS ESSENTIAL PURPOSE. THERE ARE NO WARRANTIES OTHER THAN THOSE THAT MAY BE EXPRESSLY PROVIDED FOR YOUR NEW VEHICLE.

# Appendices

## **SYNC® Automotive Important Safety Information Read and follow instructions:**

- Before using your SYNC® system, read and follow all instructions and safety information provided in this end user manual ("Owner Guide".) Not following precautions found in the Owner Guide can lead to an accident or other serious injuries.

### General Operation

- **Voice Command Control:** Certain functions within the SYNC® system may be accomplished using voice commands. Using voice commands while driving helps you to operate the system without removing your hands from the wheel or eyes from the road.
- **Prolonged Views of Screen:** Do not access any function requiring a prolonged view of the screen while you are driving. Pull over in a safe and legal manner before attempting to access a function of the system requiring prolonged attention.
- **Volume Setting:** Do not raise the volume excessively. Keep the volume at a level where you can still hear outside traffic and emergency signals while driving. Driving while unable to hear these sounds could cause an accident.
- **Navigation Features:** Any navigation features included in the system are intended to provide turn by turn instructions to get you to a desired destination. Please make certain all persons using this system carefully read and follow instructions and safety information fully.
- **Distraction Hazard:** Any navigation features may require manual (non-verbal) setup. Attempting to perform such set-up or insert data while driving can distract your attention and could cause an accident or other serious injury. Stop the vehicle in a safe and legal manner before attempting these operations.
- **Let Your Judgment Prevail:** Any navigation features are provided only as an aid. Make your driving decisions based on your observations of local conditions and existing traffic regulations. Any such feature is not a substitute for your personal judgment. Any route suggestions made by this system should never replace any local traffic regulations or your personal judgment or knowledge of safe driving practices.
- **Route Safety:** Do not follow the route suggestions if doing so would result in an unsafe or illegal maneuver, if you would be placed in an unsafe situation, or if you would be directed into an area that you consider unsafe. The driver is ultimately responsible for the safe operation of the vehicle and therefore, must evaluate whether it is safe to follow the suggested directions.
- **Potential Map Inaccuracy:** Maps used by this system may be inaccurate because of changes in roads, traffic controls or driving conditions. Always use good judgment and common sense when following the suggested routes.
- **Emergency Services:** Do not rely on any navigation features included in the system to route you to emergency services. Ask local authorities or an emergency services operator for these locations. Not all emergency services such as police, fire stations, hospitals and clinics are likely to be contained in the map database for such navigation features.

# Appendices

---

## Your Responsibilities and Assumptions of Risk

- You agree to each of the following: (a) Any use of the SOFTWARE while driving an automobile or other vehicle in violation of applicable law or otherwise driving in an unsafe manner presents a significant risk of distracted driving and should not be attempted under any circumstances; (b) Use of the SOFTWARE at excessive volume poses a significant risk of hearing damage and should not be attempted under any circumstances; (c) The SOFTWARE may not be compatible with new or different versions of an operating system, third party software, or third party services, and the SOFTWARE may potentially cause a critical failure of an operating system, third party software, or third party service. (d) Any third party service accessed by or third party software used with the SOFTWARE (i) may charge an additional fee for access, (ii) may not work correctly, on an uninterrupted basis, or error free, (iii) may change streaming formats or discontinue operation, (iv) may contain adult, profane or offensive content; and (v) may contain inaccurate, false or misleading traffic, weather, financial or safety information or other content; and (e) Use of the SOFTWARE may cause you to incur additional charges from your wireless service provider (WSP) and any data or minute calculators that may be included in the software program are for reference only, are not warranted in any way and should not be relied upon in anyway.
- When using the SOFTWARE, you agree to be responsible for and assume the entire risk to the items set forth in Section (a) – (e) above.

## Disclaimer of Warranty

YOU EXPRESSLY ACKNOWLEDGE AND AGREE THAT USE OF THE DEVICES AND SOFTWARE IS AT YOUR SOLE RISK AND THAT THE ENTIRE RISK AS TO SATISFACTORY QUALITY, PERFORMANCE, COMPATIBILITY, ACCURACY AND EFFORT IS WITH YOU. TO THE MAXIMUM EXTENT PERMITTED BY APPLICABLE LAW, THE SOFTWARE AND ANY THIRD PARTY SOFTWARE OR THIRD-PARTY SERVICES ARE PROVIDED "AS IS" AND "AS AVAILABLE", WITH ALL FAULTS AND WITHOUT WARRANTY OF ANY KIND, AND FORD MOTOR COMPANY HEREBY DISCLAIMS ALL WARRANTIES AND CONDITIONS WITH RESPECT TO THE SOFTWARE, THIRD PARTY SOFTWARE, AND THIRD-PARTY SERVICES, EITHER EXPRESS, IMPLIED OR STATUTORY, INCLUDING, BUT NOT LIMITED TO, THE IMPLIED WARRANTIES AND/OR CONDITIONS OF MERCHANTABILITY, OF SATISFACTORY QUALITY, OF FITNESS FOR AN PARTICULAR PURPOSE, OF ACCURACY, OF QUIET ENJOYMENT, AND NON-INFRINGEMENT OF THIRD-PARTY RIGHTS. FORD MOTOR COMPANY DOES NOT WARRANT (a) AGAINST INTERFERENCE WITH YOUR ENJOYMENT OF THE SOFTWARE, THIRD PARTY SOFTWARE, OR THIRD-PARTY SERVICES, (b) THAT THE SOFTWARE, THIRD PARTY SOFTWARE, OR THIRD-PARTY SERVICES WILL MEET YOUR REQUIREMENTS, (c) THAT THE OPERATION OF THE SOFTWARE, THIRD PARTY SOFTWARE, OR THIRD-PARTY SERVICES WILL BE UNINTERRUPTED OR ERROR-FREE, (d) OR THAT DEFECTS IN THE SOFTWARE, THIRD PARTY SOFTWARE, OR THIRD-PARTY SERVICES WILL BE CORRECTED. NO ORAL OR WRITTEN INFORMATION OR ADVICE GIVEN BY FORD MOTOR COMPANY OR ITS AUTHORIZED REPRESENTATIVE SHALL

# Appendices

CREATE A WARRANTY. SHOULD THE SOFTWARE, THIRD PARTY SOFTWARE, OR THIRD-PARTY SERVICES PROVE DEFECTIVE, YOU ASSUME THE ENTIRE COST OF ALL NECESSARY SERVICING, REPAIR OR CORRECTION. SOME JURISDICTIONS DO NOT ALLOW THE DISCLAIMER OF IMPLIED WARRANTIES OR LIMITATIONS ON APPLICABLE STATUTORY RIGHTS OF A CONSUMER, SO THE ABOVE DISCLAIMER MAY NOT FULLY APPLY TO YOU. THE SOLE WARRANTY PROVIDED BY FORD MOTOR COMPANY SHALL BE FOUND IN THE WARRANTY INFORMATION INCLUDING WITH YOUR OWNER GUIDE. TO THE EXTENT THAT THERE IS ANY CONFLICT BETWEEN THE TERMS OF THIS SECTION AND THE WARRANTY BOOKLET, THE WARRANTY BOOKLET SHALL CONTROL.

## Applicable Law, Venue, Jurisdiction

- The laws of the State of Michigan govern this EULA and Your use of the SOFTWARE. Your use of the SOFTWARE may also be subject to other local, state, national, or international laws. Any litigation arising out of or related to this EULA shall be brought and maintained exclusively in a court of the State of Michigan located in Wayne County or in the United States District Court for the Eastern District of Michigan. You hereby consent to submit to the personal jurisdiction of a court in the State of Michigan located in Wayne County and the United States District Court for the Eastern District of Michigan for any dispute arising out of or relating to this EULA.

## Binding Arbitration and Class Action Waiver

**(a) Application.** This Section applies to any dispute EXCEPT IT DOES NOT INCLUDE A DISPUTE RELATING TO COPYRIGHT INFRINGEMENT, OR TO THE ENFORCEMENT OR VALIDITY OF YOUR, FORD MOTOR COMPANY, OR ANY OF FORD MOTOR COMPANY'S LICENSORS' INTELLECTUAL PROPERTY RIGHTS.

Dispute means any dispute, action, or other controversy between You and FORD MOTOR COMPANY, other than the exceptions listed above, concerning the SOFTWARE (including its price) or this EULA, whether in contract, warranty, tort, statute, regulation, ordinance, or any other legal or equitable basis.

**(b) Notice of Dispute.** In the event of a Dispute, You or FORD MOTOR COMPANY must give the other a "Notice of Dispute", which is a written statement of the name, address, and contact information of the party giving it, the facts giving rise to the dispute, and the relief requested. You and FORD MOTOR COMPANY will attempt to resolve any dispute through informal negotiation within 60 days from the date the Notice of Dispute is sent. After 60 days, You or FORD MOTOR COMPANY may commence arbitration.

**(c) Small claims court.** You may also litigate any dispute in small claims court in your county of residence or FORD MOTOR COMPANY'S principal place of business, if the dispute meets all requirements to be heard in the small claims court. You may litigate in small claims court whether or not You negotiated informally first.

**(d) Binding arbitration.** If You and FORD MOTOR COMPANY, do not resolve any dispute by informal negotiation or in small claims court, any other effort to resolve the dispute will be conducted exclusively by binding arbitration. You are giving up

## Appendices

---

the right to litigate (or participate in as a party or class member) all disputes in court before a judge or jury. Instead, all disputes will be resolved before a neutral arbitrator, whose decision will be final except for a limited right of appeal under the Federal Arbitration Act. Any court with jurisdiction over the parties may enforce the arbitrator's award.

**(e) Class action waiver.** Any proceedings to resolve or litigate any dispute in any forum will be conducted solely on an individual basis. Neither you nor FORD MOTOR COMPANY, will seek to have any dispute heard as a class action, as a private attorney general action, or in any other proceeding in which any party acts or proposes to act in a representative capacity. No arbitration or proceeding will be combined with another without the prior written consent of all parties to all affected arbitrations or proceedings.

**(f) Arbitration procedure.** Any arbitration will be conducted by the American Arbitration Association (the "AAA"), under its Commercial Arbitration Rules. If You are an individual and use the SOFTWARE for personal or vehicle use, or if the value of the dispute is \$75,000 or less whether or not You are an individual or how You use the SOFTWARE, the AAA Supplementary Procedures for Consumer-Related Disputes will also apply. To commence arbitration, submit a Commercial Arbitration Rules Demand for Arbitration form to the AAA. You may request a telephonic or in-person hearing by following the AAA rules. In a dispute involving \$10,000 or less, any hearing will be telephonic unless the arbitrator finds good cause to hold an in-person hearing instead. For more information, see [adr.org](http://adr.org) or call 1-800-778-7879. You agree to commence arbitration only in your county of residence or FORD MOTOR COMPANY'S principal place of business. The arbitrator

may award the same damages to You individually as a court could. The arbitrator may award declaratory or injunctive relief only to You individually, and only to the extent required to satisfy Your individual claim.

### **(g) Arbitration fees and incentives.**

- I. Disputes involving \$75,000 or less. FORD MOTOR COMPANY will promptly reimburse your filing fees and pay the AAA's and arbitrator's fees and expenses. If you reject FORD MOTOR COMPANY'S last written settlement offer made before the arbitrator was appointed ("last written offer"), your dispute goes all the way to an arbitrator's decision (called an "award"), and the arbitrator awards you more than the last written offer, FORD MOTOR COMPANY will give you three incentives: (1) pay the greater of the award or \$1,000; (2) pay twice your reasonable attorney's fees, if any; and (3) reimburse any expenses (including expert witness fees and costs) that your attorney reasonably accrues for investigating, preparing, and pursuing your claim in arbitration. The arbitrator will determine the amounts.
- ii. Disputes involving more than \$75,000. The AAA rules will govern payment of filing fees and the AAA's and arbitrator's fees and expenses.
- iii. Disputes involving any amount. In any arbitration you commence, FORD MOTOR COMPANY will seek its AAA or arbitrator's fees and expenses, or Your filing fees it reimbursed, only if the arbitrator finds the arbitration frivolous or brought for an improper purpose. In any arbitration FORD MOTOR COMPANY commences, it will pay all

# Appendices

---

filing, AAA, and arbitrator's fees and expenses. It will not seek its attorney's fees or expenses from you in any arbitration. Fees and expenses are not counted in determining how much a dispute involves.

**(h) Claims or disputes must be filed within one year.** To the extent permitted by law, any claim or dispute under this EULA to which this Section applies must be filed within one year in small claims court (Section c) or in arbitration (Section d). The one-year period begins when the claim or dispute first could be filed. If such a claim or dispute is not filed within one year, it is permanently barred.

**(i) Severability.** If the class action waiver (Section e) is found to be illegal or unenforceable as to all or some parts of a dispute, then that portion of Section e will not apply to those parts. Instead, those parts will be severed and proceed in a court of law, with the remaining parts proceeding in arbitration. If any other provision of that portion Section e is found to be illegal or unenforceable, that provision will be severed with the remainder of Section e remaining in full force and effect.

## **Telenav Software End User License Agreement**

Please read these terms and conditions carefully before you use the TeleNav Software. Your use of the TeleNav Software indicates that you accept these terms and conditions. If you do not accept these terms and conditions, do not break the seal of the package, launch, or otherwise use the TeleNav Software. TeleNav may revise this Agreement and the privacy policy at any time, with or without notice to you. You agree to visit <http://www.telenav.com> from time to time to review the then current version of this Agreement and of the privacy policy.

## **1. Safe and Lawful Use**

You acknowledge that devoting attention to the TeleNav Software may pose a risk of injury or death to you and others in situations that otherwise require your undivided attention, and you therefore agree to comply with the following when using the TeleNav Software:

- (a) observe all traffic laws and otherwise drive safely;
  - (b) use your own personal judgment while driving. If you feel that a route suggested by the TeleNav Software instructs you to perform an unsafe or illegal maneuver, places you in an unsafe situation, or directs you into an area that you consider to be unsafe, do not follow such instructions;
  - (c) do not input destinations, or otherwise manipulate the TeleNav Software, unless your vehicle is stationary and parked;
  - (d) do not use the TeleNav Software for any illegal, unauthorized, unintended, unsafe, hazardous, or unlawful purposes, or in any manner inconsistent with this Agreement;
  - (e) arrange all GPS and wireless devices and cables necessary for use of the TeleNav Software in a secure manner in your vehicle so that they will not interfere with your driving and will not prevent the operation of any safety device (such as an airbag).
- You agree to indemnify and hold TeleNav harmless against all claims resulting from any dangerous or otherwise inappropriate use of the TeleNav Software in any moving vehicle, including as a result of your failure to comply with the directions above.

# Appendices

---

## 2. Account Information

You agree: (a) when registering the TeleNav Software, to provide TeleNav with true, accurate, current, and complete information about yourself, and (b) to inform TeleNav promptly of any changes to such information, and to keep it true, accurate, current and complete.

## 3. Software License

- Subject to your compliance with the terms of this Agreement, TeleNav hereby grants to you a personal, non-exclusive, non-transferable license (except as expressly permitted below in connection with your permanent transfer of the TeleNav Software license), without the right to sublicense, to use the TeleNav Software (in object code form only) in order to access and use the TeleNav Software. This license shall terminate upon any termination or expiration of this Agreement. You agree that you will use the TeleNav Software only for your personal business or leisure purposes, and not to provide commercial navigation services to other parties.

### 3.1 License Limitations

- **(a)** reverse engineer, decompile, disassemble, translate, modify, alter or otherwise change the TeleNav Software or any part thereof; **(b)** attempt to derive the source code, audio library or structure of the TeleNav Software without the prior express written consent of TeleNav; **(c)** remove from the TeleNav Software, or alter, any of TeleNav's or its suppliers' trademarks, trade names, logos, patent or copyright notices, or other notices or markings; **(d)**

distribute, sublicense or otherwise transfer the TeleNav Software to others, except as part of your permanent transfer of the TeleNav Software; or **(e)** use the TeleNav Software in any manner that

- i. infringes the intellectual property or proprietary rights, rights of publicity or privacy or other rights of any party,
- ii. violates any law, statute, ordinance or regulation, including but not limited to laws and regulations related to spamming, privacy, consumer and child protection, obscenity or defamation, or
- iii. is harmful, threatening, abusive, harassing, tortuous, defamatory, vulgar, obscene, libelous, or otherwise objectionable; and (f) lease, rent out, or otherwise permit unauthorized access by third parties to the TeleNav Software without advanced written permission of TeleNav.

## 4. Disclaimers

- To the fullest extent permissible pursuant to applicable law, in no event will TeleNav, its licensors and suppliers, or agents or employees of any of the foregoing, be liable for any decision made or action taken by you or anyone else in reliance on the information provided by the TeleNav Software. TeleNav also does not warrant the accuracy of the map or other data used for the TeleNav Software. Such data may not always reflect reality due to, among other things, road closures, construction, weather, new roads and other changing conditions. You are responsible for the entire risk arising out of your use of the TeleNav Software. For example but without limitation, you agree not to rely on the TeleNav Software for critical navigation in areas where the well-being or survival of you or others

# Appendices

---

is dependent on the accuracy of navigation, as the maps or functionality of the TeleNav Software are not intended to support such high risk applications, especially in more remote geographical areas.

- TELENAV EXPRESSLY DISCLAIMS AND EXCLUDES ALL WARRANTIES IN CONNECTION WITH THE TELENAV SOFTWARE, WHETHER STATUTORY, EXPRESS OR IMPLIED, INCLUDING ALL WARRANTIES WHICH MAY ARISE FROM COURSE OF DEALING, CUSTOM OR TRADE AND INCLUDING, BUT NOT LIMITED TO, THE IMPLIED WARRANTIES OF MERCHANTABILITY, FITNESS FOR A PARTICULAR PURPOSE AND NON-INFRINGEMENT OF THIRD PARTY RIGHTS WITH RESPECT TO THE TELENAV SOFTWARE.
- Certain jurisdictions do not permit the disclaimer of certain warranties, so this limitation may not apply to you.

## **5. Limitation of Liability**

- TO THE EXTENT PERMITTED UNDER APPLICABLE LAW, UNDER NO CIRCUMSTANCES SHALL TELENAV OR ITS LICENSORS AND SUPPLIERS BE LIABLE TO YOU OR TO ANY THIRD PARTY FOR ANY INDIRECT, INCIDENTAL, CONSEQUENTIAL, SPECIAL OR EXEMPLARY DAMAGES (INCLUDING IN EACH CASE, BUT NOT LIMITED TO, DAMAGES FOR THE INABILITY TO USE THE EQUIPMENT OR ACCESS DATA, LOSS OF DATA, LOSS OF BUSINESS, LOSS OF PROFITS, BUSINESS INTERRUPTION OR THE LIKE) ARISING OUT OF THE USE OF OR INABILITY TO USE THE TELENAV SOFTWARE, EVEN IF TELENAV HAS BEEN ADVISED OF THE POSSIBILITY OF SUCH DAMAGES. NOTWITHSTANDING ANY DAMAGES THAT YOU MIGHT INCUR FOR ANY

REASON WHATSOEVER (INCLUDING, WITHOUT LIMITATION, ALL DAMAGES REFERENCED HEREIN AND ALL DIRECT OR GENERAL DAMAGES IN CONTRACT, TORT (INCLUDING NEGLIGENCE) OR OTHERWISE), THE ENTIRE LIABILITY OF TELENAV AND OF ALL OF TELENAV'S SUPPLIERS SHALL BE LIMITED TO THE AMOUNT ACTUALLY PAID BY YOU FOR THE TELENAV SOFTWARE. SOME STATES AND/OR JURISDICTIONS DO NOT ALLOW THE EXCLUSION OR LIMITATION OF INCIDENTAL OR CONSEQUENTIAL DAMAGES, SO THE ABOVE LIMITATIONS OR EXCLUSIONS MAY NOT APPLY TO YOU.

## **6. Arbitration and Governing Law**

- You agree that any dispute, claim or controversy arising out of or relating to this Agreement or the TeleNav Software shall be settled by independent arbitration involving a neutral arbitrator and administered by the American Arbitration Association in the County of Santa Clara, California. The arbitrator shall apply the Commercial Arbitration Rules of the American Arbitration Association, and the judgment upon the award rendered by the arbitrator may be entered by any court having jurisdiction. Note that there is no judge or jury in an arbitration proceeding and the decision of the arbitrator shall be binding upon both parties. You expressly agree to waive your right to a jury trial. This Agreement and performance hereunder will be governed by and construed in accordance with the laws of the State of California, without giving effect to its conflict of law provisions. To the extent judicial action is necessary in connection with the binding arbitration, both TeleNav and you agree to submit

# Appendices

---

to the exclusive jurisdiction of the courts of the County of Santa Clara, California. The United Nations Convention on Contracts for the International Sale of Goods shall not apply.

## **7. Assignment**

- You may not resell, assign, or transfer this Agreement or any of your rights or obligations, except in totality, in connection with your permanent transfer of the TeleNav Software, and expressly conditioned upon the new user of the TeleNav Software agreeing to be bound by the terms and conditions of this Agreement. Any such sale, assignment or transfer that is not expressly permitted under this paragraph will result in immediate termination of this Agreement, without liability to TeleNav, in which case you and all other parties shall immediately cease all use of the TeleNav Software. Notwithstanding the foregoing, TeleNav may assign this Agreement to any other party at any time without notice, provided the assignee remains bound by this Agreement.

## **8. Miscellaneous**

### **8.1**

This Agreement constitutes the entire agreement between TeleNav and you with respect to the subject matter hereof.

### **8.2**

Except for the limited licenses expressly granted in this Agreement, TeleNav retains all right, title and interest in and to the TeleNav Software, including without limitation all related intellectual property rights. No licenses or other rights which are not expressly granted in this Agreement are intended to, or shall be, granted or

conferred by implication, statute, inducement, estoppel or otherwise, and TeleNav and its suppliers and licensors hereby reserve all of their respective rights other than the licenses explicitly granted in this Agreement.

### **8.3**

By using the TeleNav Software, you consent to receive from TeleNav all communications, including notices, agreements, legally required disclosures or other information in connection with the TeleNav Software (collectively, "Notices") electronically. TeleNav may provide such Notices by posting them on TeleNav's Website or by downloading such Notices to your wireless device. If you desire to withdraw your consent to receive Notices electronically, you must discontinue your use of the TeleNav Software.

### **8.4**

TeleNav's or your failure to require performance of any provision shall not affect that party's right to require performance at any time thereafter, nor shall a waiver of any breach or default of this Agreement constitute a waiver of any subsequent breach or default or a waiver of the provision itself.

### **8.5**

If any provision herein is held unenforceable, then such provision will be modified to reflect the intention of the parties, and the remaining provisions of this Agreement will remain in full force and effect.

# Appendices

## 8.6

The headings in this Agreement are for convenience of reference only, will not be deemed to be a part of this Agreement, and will not be referred to in connection with the construction or interpretation of this Agreement. As used in this Agreement, the words "include" and "including" and variations thereof, will not be deemed to be terms of limitation, but rather will be deemed to be followed by the words "without limitation".

## 9. Other Vendors Terms and Conditions

- The Telenav Software utilizes map and other data licensed to Telenav by third party vendors for the benefit of you and other end users. This Agreement includes end-user terms applicable to these companies (included at the end of this Agreement), and thus your use of the Telenav Software is also subject to such terms. You agree to comply with the following additional terms and conditions, which are applicable to Telenav's third party vendor licensors::

### 9.1 End User Terms Required by HERE North America, LLC

The data ("Data") is provided for your personal, internal use only and not for resale. It is protected by copyright, and is subject to the following terms and conditions which are agreed to by you, on the one hand, and Telenav ("Telenav") and its licensors (including their licensors and suppliers) on the other hand.

© 2013 HERE. All rights reserved.

The Data for areas of Canada includes information taken with permission from Canadian authorities, including: © Her Majesty the Queen in Right of Canada, © Queen's Printer for Ontario, © Canada Post Corporation, GeoBase®, © Department of Natural Resources Canada.

HERE holds a non-exclusive license from the United States Postal Service® to publish and sell ZIP+4® information.

©United States Postal Service® 2014. Prices are not established, controlled or approved by the United States Postal Service®. The following trademarks and registrations are owned by the USPS: United States Postal Service, USPS, and ZIP+4

The Data for Mexico includes certain data from Instituto Nacional de Estadística y Geografía.

### 9.2 End User Terms Required by NAV2 (Shanghai) Co., Ltd

The data ("Data") is provided for your personal, internal use only and not for resale. It is protected by copyright, and is subject to the following terms and conditions which are agreed to by you, on the one hand, and NAV2 (Shanghai) Co., Ltd ("NAV2") and its licensors (including their licensors and suppliers) on the other hand. 20xx. All rights reserved

#### Terms and Conditions

**Permitted Use.** You agree to use this Data together with the Telenav Software solely for the internal business and personal purposes for which you were licensed, and not for service bureau, time-sharing or other similar purposes. Accordingly, but subject to the restrictions set forth in the following paragraphs, you agree not to otherwise reproduce, copy, modify, decompile, disassemble, create any derivative works of, or reverse engineer any portion of this Data, and may not transfer or distribute it in any form, for any purpose, except to the extent permitted by mandatory laws.

# Appendices

---

**Restrictions.** Except where you have been specifically licensed to do so by Telenav, and without limiting the preceding paragraph, you may not use this Data (a) with any products, systems, or applications installed or otherwise connected to or in communication with vehicles, capable of vehicle navigation, positioning, dispatch, real time route guidance, fleet management or similar applications; or (b) with or in communication with any positioning devices or any mobile or wireless-connected electronic or computer devices, including without limitation cellular phones, palmtop and handheld computers, pagers, and personal digital assistants or PDAs.

**Warning.** The Data may contain inaccurate or incomplete information due to the passage of time, changing circumstances, sources used and the nature of collecting comprehensive geographic data, any of which may lead to incorrect results.

**No Warranty.** This Data is provided to you “as is,” and you agree to use it at your own risk. Telenav and its licensors (and their licensors and suppliers) make no guarantees, representations or warranties of any kind, express or implied, arising by law or otherwise, including but not limited to, content, quality, accuracy, completeness, effectiveness, reliability, fitness for a particular purpose, usefulness, use or results to be obtained from this Data, or that the Data or server will be uninterrupted or error-free.

**Disclaimer of Warranty:** TELENAV AND ITS LICENSORS (INCLUDING THEIR LICENSORS AND SUPPLIERS) DISCLAIM ANY WARRANTIES, EXPRESS OR IMPLIED, OF QUALITY, PERFORMANCE, MERCHANTABILITY, FITNESS FOR A

PARTICULAR PURPOSE OR NON-INFRINGEMENT. Some States, Territories and Countries do not allow certain warranty exclusions, so to that extent the above exclusion may not apply to you.

**Disclaimer of Liability:** TELENAV AND ITS LICENSORS (INCLUDING THEIR LICENSORS AND SUPPLIERS) SHALL NOT BE LIABLE TO YOU: IN RESPECT OF ANY CLAIM, DEMAND OR ACTION, IRRESPECTIVE OF THE NATURE OF THE CAUSE OF THE CLAIM, DEMAND OR ACTION ALLEGING ANY LOSS, INJURY OR DAMAGES, DIRECT OR INDIRECT, WHICH MAY RESULT FROM THE USE OR POSSESSION OF THE INFORMATION; OR FOR ANY LOSS OF PROFIT, REVENUE, CONTRACTS OR SAVINGS, OR ANY OTHER DIRECT, INDIRECT, INCIDENTAL, SPECIAL OR CONSEQUENTIAL DAMAGES ARISING OUT OF YOUR USE OF OR INABILITY TO USE THIS INFORMATION, ANY DEFECT IN THE INFORMATION, OR THE BREACH OF THESE TERMS OR CONDITIONS, WHETHER IN AN ACTION IN CONTRACT OR TORT OR BASED ON A WARRANTY, EVEN IF TELENAV OR ITS LICENSORS HAVE BEEN ADVISED OF THE POSSIBILITY OF SUCH DAMAGES. Some States, Territories and Countries do not allow certain liability exclusions or damages limitations, so to that extent the above may not apply to you.

**Export Control.** You shall not export from anywhere any part of the Data or any direct product thereof except in compliance with, and with all licenses and approvals required under, applicable export laws, rules and regulations, including but not limited to the laws, rules and regulations administered by the Office of Foreign Assets Control of the U.S. Department of Commerce and the Bureau of Industry and Security of the U.S. Department of Commerce. To the extent that any such

# Appendices

export laws, rules or regulations prohibit HERE from complying with any of its obligations hereunder to deliver or distribute Data, such failure shall be excused and shall not constitute a breach of this Agreement.

**Entire Agreement.** These terms and conditions constitute the entire agreement between Telenav (and its licensors, including their licensors and suppliers) and you pertaining to the subject matter hereof, and supersedes in their entirety any and all written or oral agreements previously existing between us with respect to such subject matter.

**Governing Law.** The above terms and conditions shall be governed by the laws of the State of Illinois [insert "Netherlands" where European HERE Data is used], without giving effect to (i) its conflict of laws provisions, or (ii) the United Nations Convention for Contracts for the International Sale of Goods, which is explicitly excluded. You agree to submit to the jurisdiction of the State of Illinois [insert "The Netherlands" where European HERE Data is used] for any and all disputes, claims and actions arising from or in connection with the Data provided to you hereunder.

**Government End Users.** If the Data is being acquired by or on behalf of the United States government or any other entity seeking or applying rights similar to those customarily claimed by the United States government, this Data is a "commercial item" as that term is defined at 48 C.F.R. ("FAR") 2.101, is licensed in accordance with these End-User Terms, and each copy of Data delivered or otherwise furnished shall be marked and embedded as appropriate with the following "Notice of Use," and shall be treated in accordance with such Notice:

NOTICE OF USE
CONTRACTOR (MANUFACTURER/SUPPLIER) NAME: HERE
CONTRACTOR (MANUFACTURER/SUPPLIER) ADDRESS: c/o Nokia, 425 West Randolph Street, Chicago, Illinois 60606
This Data is a commercial item as defined in FAR 2.101 and is subject to these End-User Terms under which this Data was provided.
© 1987 – 2014 HERE – All rights reserved.

If the Contracting Officer, federal government agency, or any federal official refuses to use the legend provided herein, the Contracting Officer, federal government agency, or any federal official must notify HERE prior to seeking additional or alternative rights in the Data.

## I. US/Canada Territory

A. United States Data. The End-User Terms for any Application containing Data for the United States shall contain the following notices:

"HERE holds a non-exclusive license from the United States Postal Service® to publish and sell ZIP+4® information."

"©United States Postal Service® 20XX. Prices are not established, controlled or approved by the United States Postal Service®. The following trademarks and registrations are owned by the USPS: United States Postal Service, USPS, and ZIP+4."

## Appendices

---

B. Canada Data. The following provisions apply to the Data for Canada, which may include or reflect data from third party licensors (“Third Party Data”), including Her Majesty the Queen in Right of Canada (“Her Majesty”), Canada Post Corporation (“Canada Post”) and the Department of Natural Resources of Canada (“NRCan”):

1. Disclaimer and Limitation: Client agrees that its use of the Third Party Data is subject to the following provisions:

a. Disclaimer: The Third Party Data is licensed on an “as is” basis. The licensors of such data, including Her Majesty, Canada Post and NRCan, make no guarantees, representations or warranties respecting such data, either express or implied, arising by law or otherwise, including but not limited to, effectiveness, completeness, accuracy or fitness for a particular purpose.

b. Limitation on Liability: The Third Party Data licensors, including Her Majesty, Canada Post and NRCan, shall not be liable: (i) in respect of any claim, demand or action, irrespective of the nature of the cause of the claim, demand or action alleging any loss, injury or damages, direct or indirect, which may result from the use or possession of such Data; or (ii) in any way for loss of revenues or contracts, or any other consequential loss of any kind resulting from any defect in the Data.

2. Copyright Notice: In connection with each copy of all or any portion of the Data for the Territory of Canada, Client shall affix in a conspicuous manner the following copyright notice on at least one of: (i) the label for the storage media of the copy; (ii) the packaging for the copy; or (iii) other materials packaged with the copy, such as user manuals or end user license agreements: “This data includes information taken with permission from Canadian authorities, including © Her Majesty the Queen in Right of Canada, © Queen’s Printer for Ontario, © Canada Post Corporation, GeoBase®, © The Department of Natural Resources Canada. All rights reserved.”

3. End-User Terms: Except as otherwise agreed by the parties, in connection with the provision of any portion of the Data for the Territory of Canada to End-Users as may be authorized under the Agreement, Client shall provide such End-Users, in a reasonably conspicuous manner, with terms (set forth with other end user terms required to be provided under the Agreement, or as otherwise may be provided, by Client) which shall include the following provisions on behalf of the Third Party Data licensors, including Her Majesty, Canada Post and NRCan:

The Data may include or reflect data of licensors, including Her Majesty the Queen in the Right of Canada (“Her Majesty”), Canada Post Corporation (“Canada Post”) and the Department of Natural Resources Canada (“NRCan”). Such data is licensed on an “as is” basis. The licensors, including Her Majesty, Canada Post and NRCan, make no guarantees, representations or warranties respecting such data,

# Appendices

either express or implied, arising by law or otherwise, including but not limited to, effectiveness, completeness, accuracy or fitness for a particular purpose. The licensors, including Her Majesty, Canada Post and NRCan, shall not be liable in respect of any claim, demand or action, irrespective of the nature of the cause of the claim, demand or action alleging any loss, injury or damages, direct or indirect, which may result from the use or possession of the data or the Data. The licensors, including Her Majesty, Canada Post and NRCan, shall not be liable in any way for loss of revenues or contracts, or any other consequential loss of any kind resulting from any defect in the data or the Data.

End User shall indemnify and save harmless the licensors, including Her Majesty, Canada Post and NRCan, and their officers, employees and agents from and against any claim, demand or action, irrespective of the nature of the cause of the claim, demand or action, alleging loss, costs, expenses, damages or injuries (including injuries resulting in death) arising out of the use or possession of the data or the Data.

4. Additional Provisions: The terms contained in this Section are in addition to all of the rights and obligations of the parties under the Agreement. To the extent that any of the provisions of this Section are inconsistent with, or conflict with, any other provisions of the Agreement, the provisions of this Section shall prevail.

II. Mexico. The following provision applies to the Data for Mexico, which includes certain data from the Instituto Nacional de Estadística y Geografía (“INEGI”):

A. Any and all copies of the Data and/or packaging containing Data for Mexico shall contain the following notice: “Fuente: INEGI (Instituto Nacional de Estadística y Geografía)”

III. Latin America Territory

A. Third Party Notices. Any and all copies of the Data and/or packaging relating thereto shall include the respective Third Party Notices set forth below and used as described below corresponding to the Territory (or portion thereof) included in such copy:

Territory	Notice
Argentina	IGN “INSTITUTO GEOGRAFICO NACIONAL ARGENTINO”
Ecuador	“INSTITUTO GEOGRAFICO MILITAR DEL ECUADOR AUTORIZACION N° IGM-2011-01- PCO-01 DEL 25 DE ENERO DE 2011” “source: © IGN 2009 - BD TOPO ®”
Guadeloupe, French Guiana and Martinique Mexico	“Fuente: INEGI (Instituto Nacional de Estadística y Geografía)”

IV. Middle East Territory

# Appendices

---

A. Third Party Notices. Any and all copies of the Data and/or packaging relating thereto shall include the respective Third Party Notices set forth below and used as described below corresponding to the Territory (or portion thereof) included in such copy:

Country	Notice
Jordan	“© Royal Jordanian Geographic Centre”. The foregoing notice requirement for Jordan Data is a material term of the Agreement. If Client or any of its permitted sublicensees (if any) fail to meet such requirement, HERE shall have the right to terminate Client’s license with respect to the Jordan Data.

B. Jordan Data. Client and its permitted sublicensees (if any) are restricted from licensing and/or otherwise distributing HERE’s database for the country of Jordan (“Jordan Data”) for use in Enterprise Applications to (i) non-Jordanian entities for use of the Jordan Data solely in Jordan or (ii) Jordan-based customers. In addition, Client, its permitted sublicensees (if any) and End-Users are restricted from using the Jordan Data in Enterprise Applications if such party is (i) a non-Jordanian entity using the Jordan Data solely in Jordan or (ii) a Jordan-based customer. For purposes of the foregoing, “Enterprise Applications” shall mean Geomarketing applications, GIS applications, mobile business asset management applications, call center applications, telematics applications, public organization Internet applications or for providing geocoding services.

## V. Europe Territory

### A. Use of Certain Traffic Codes in Europe

1. General Restrictions Applicable to Traffic Codes. Client acknowledges and agrees that in certain countries of the Europe Territory, Client will need to obtain rights directly from third party RDS-TMC code providers to receive and use the Traffic Codes in the Data and to deliver to End-Users Transactions in any way derived from or based on such Traffic Codes. For such countries, HERE shall deliver the Data incorporating Traffic Codes to Client only after receiving certification from Client of its having obtained such rights.

2. Display of Third Party Rights Legends for Belgium. Client shall, for each Transaction that uses Traffic Codes for Belgium, provide the following notice to the End-User: “Traffic Codes for Belgium are provided by the Ministerie van de Vlaamse Gemeenschap and the Ministère de l’Equipement et des Transports.”

B. Paper Maps. With respect to any license granted to Client relating to making, selling or distributing paper maps (i.e., a map fixed on a paper or paper-like medium): (a) such license with respect to Data for the Territory of Great Britain is conditioned on Client’s entering into and complying with a separate written agreement with the Ordnance Survey (“OS”) to create and sell paper maps, Client’s paying to the OS any and all applicable paper map royalties, and Client’s complying with the OS copyright notice requirements; (b) such license for selling or otherwise distributing for charge with respect to Data for the Territory of Czech Republic

# Appendices

is conditioned on Client's obtaining prior written consent from Kartografie a.s.; (c) such license for selling or distributing with respect to Data for the Territory of Switzerland is conditioned on Client's obtaining a permit from Bundesamt für Landestopografie of Switzerland; (d) Client is restricted from using Data for the Territory of France to create paper maps with a scale between 1:5,000 and 1:250,000; and (e) Client is restricted from using any Data to create, sell or distribute paper maps that are the same or substantially similar, in terms of data content and specific use of color, symbols and scale, to paper maps published by the European national mapping agencies, including without limitation, Landervermessungämter of Germany, Topografische Dienst of the Netherlands, Nationaal Geografisch Instituut of Belgium, Bundesamt für Landestopografie of Switzerland, Bundesamt für Eich-und Vermessungswesen of Austria, and the National Land Survey of Sweden.

C. OS Enforcement. Without limiting Section IV(B) above, with respect to Data for the Territory of Great Britain, Client acknowledges and agrees that the Ordnance Survey ("OS") may bring a direct action against Client to enforce compliance with the OS copyright notice (see Section IV(D) below) and paper map requirements (see Section IV(B) above) contained in this Agreement.

D. Third Party Notices. Any and all copies of the Data and/or packaging relating thereto shall include the respective Third Party Notices set forth below and used as described below corresponding to the Territory (or portion thereof) included in such copy:

Country(ies) Notice

Austria	"© Bundesamt für Eich- und Vermessungswesen"
Croatia Cyprus, Estonia, Latvia, Lithuania, Moldova, Poland, Slovenia and/or Ukraine	"© EuroGeographics"
France	"source: © IGN 2009 – BD TOPO ®"
Germany	"Die Grundlagendaten wurden mit Genehmigung der zuständigen Behörden entnommen"
Great Britain	"Contains Ordnance Survey data © Crown copyright and database right 2010 Contains Royal Mail data © Royal Mail copyright and database right 2010"
Greece	"Copyright Geomatics Ltd."
Hungary	"Copyright © 2003; Top-Map Ltd."
Italy	"La Banca Dati Italiana è stata prodotta usando quale riferimento anche cartografia numerica ed al tratto prodotta e fornita dalla Regione Toscana."
Norway	"Copyright © 2000; Norwegian Mapping Authority"
Portugal	"Source: IgeoE – Portugal"

# Appendices

Spain	“Información geográfica propiedad del CNIG”
Sweden	“Based upon electronic data © National Land Survey Sweden.”
Switzerland	“Topografische Grundlage: © Bundesamt für Landestopographie.

Product incorporates data which is © 20XX Telstra Corporation Limited, GM Holden Limited, Intelomatics Australia Pty Ltd and Continental Pty Ltd.

B. Third Party Notices for Australia. In addition to the foregoing, the End-User Terms for any Application containing RDS-TMC Traffic Codes for Australia shall contain the following notice: “Product incorporates traffic location codes which is © 20XX Telstra Corporation Limited and its licensors.”

E. Respective Country Distribution. Client acknowledges that HERE has not received approvals to distribute map data for the following countries in such respective countries: Albania, Belarus, Kyrgyzstan, Moldova and Uzbekistan. HERE may update such list from time to time. The license rights granted to Client under this TL with respect to the Data for such countries are contingent upon Client’s compliance with all applicable laws and regulations, including, without limitation, any required licenses or approvals to distribute the Application incorporating such Data in such respective countries.

## VII. China Territory

### *Personal Use Only*

You agree to use this Data together with [insert name of Client Application] for the solely personal, non-commercial purposes for which you were licensed, and not for service bureau, time-sharing or other similar purposes. Accordingly, but subject to the restrictions set forth in the following paragraphs, you may copy this Data only as necessary for your personal use to (i) view it, and (ii) save it, provided that you do not remove any copyright notices that appear and do not modify the Data in any way. You agree not to otherwise reproduce, copy, modify, decompile, disassemble or reverse engineer any portion of this Data, and may not transfer or distribute it in any form, for any purpose, except to the extent permitted by mandatory laws.

### *Restrictions*

Except where you have been specifically licensed to do so by NAV2 , and without limiting the preceding paragraph, you may not (a) use this Data with any products, systems, or applications installed or otherwise connected to or in communication with vehicles, capable of vehicle navigation, positioning, dispatch, real time route guidance, fleet management or similar applications; or (b)

## VI. Australia Territory

A. Third Party Notices. Any and all copies of the Data and/or packaging relating thereto shall include the respective Third Party Notices set forth below and used as described below corresponding to the Territory (or portion thereof) included in such copy:

Copyright. Based on data provided under license from PSMA Australia Limited ([www.pasma.com.au](http://www.pasma.com.au)).

# Appendices

---

with or in communication with any positioning devices or any mobile or wireless-connected electronic or computer devices, including without limitation cellular phones, palmtop and handheld computers, pagers, and personal digital assistants or PDAs. You agree to cease using this Data if you fail to comply with these terms and conditions.

## **Limited Warranty**

NAV2 warrants that (a) the Data will perform substantially in accordance with the accompanying written materials for a period of ninety (90) days from the date of receipt, and (b) any support services provided by NAV2 shall be substantially as described in applicable written materials provided to you by NAV2, and NAV2's support engineers will make commercially reasonable efforts to solve any problem issues.

## **rigCustomer Remedies**

NAV2 and its suppliers' entire liability and your exclusive remedy shall be, at NAV2's sole discretion, either (a) return of the price paid, if any, or (b) repair or replacement of the Data that do not meet NAV2's Limited Warranty and that are returned to NAV2 with a copy of your receipt. This Limited Warranty is void if failure of the Data has resulted from accident, abuse, or misapplication. Any replacement Data will be warranted for the remainder of the original warranty period or thirty (30) days, whichever is longer. Neither these remedies nor any product support services offered by NAV2 are available without proof of purchase from an authorized international source.

## **No Other Warranty:**

EXCEPT FOR THE LIMITED WARRANTY SET FORTH ABOVE AND TO THE EXTENT PERMITTED BY APPLICABLE LAW, NAV2 AND ITS LICENSORS (INCLUDING THEIR LICENSORS AND SUPPLIERS) DISCLAIM ANY WARRANTIES, EXPRESS OR IMPLIED, OF QUALITY, PERFORMANCE, MERCHANTABILITY, FITNESS FOR A PARTICULAR PURPOSE, OWNERSHIP OR NON-INFRINGEMENT. Certain warranty exclusions may not be permitted under applicable law, so to that extent the above exclusion may not apply to you.

## **Limited Liability:**

TO THE EXTENT PERMITTED BY APPLICABLE LAW, NAV2 AND ITS LICENSORS (INCLUDING THEIR LICENSORS AND SUPPLIERS) SHALL NOT BE LIABLE TO YOU: IN RESPECT OF ANY CLAIM, DEMAND OR ACTION, IRRESPECTIVE OF THE NATURE OF THE CAUSE OF THE CLAIM, DEMAND OR ACTION ALLEGING ANY LOSS, INJURY OR DAMAGES, DIRECT OR INDIRECT, WHICH MAY RESULT FROM THE USE OR POSSESSION OF THE INFORMATION; OR FOR ANY LOSS OF PROFIT, REVENUE, CONTRACTS OR SAVINGS, OR ANY OTHER DIRECT, INDIRECT, INCIDENTAL, SPECIAL OR CONSEQUENTIAL DAMAGES ARISING OUT OF YOUR USE OF OR INABILITY TO USE THIS INFORMATION, ANY DEFECT IN THE INFORMATION, OR THE BREACH OF THESE TERMS OR CONDITIONS, WHETHER IN AN ACTION IN CONTRACT OR TORT OR BASED ON A WARRANTY, EVEN IF NAV2 OR ITS LICENSORS HAVE BEEN ADVISED OF THE POSSIBILITY OF SUCH DAMAGES. UNDER NO CIRCUMSTANCES SHALL NAV2'S OR ITS SUPPLIERS' LIABILITY HEREUNDER EXCEED THE PRICE PAID. Certain liability exclusions may not be permitted under applicable law, so to that extent the above exclusion may not apply to you.

# Appendices

---

## **Export Control**

You agree not to export to anywhere any part of the Data provided to you or any direct product thereof except in compliance with, and with all licenses and approvals required under, applicable export laws, rules and regulations.

## **IP Protection**

The Data are owned by NAV2 or its suppliers and are protected by applicable copyright and other intellectual property law and treaties. The Data are provided solely on the basis of a license to use, not sale.

## **Entire Agreement**

These terms and conditions constitute the entire agreement between NAV2 (and its licensors, including their licensors and suppliers) and you pertaining to the subject matter hereof, and supersedes in their entirety any and all written or oral agreements previously existing between us with respect to such subject matter.

## **Governing Law.**

The above terms and conditions shall be governed by the laws of the People's Republic of China, without giving effect to (i) its conflict of laws provisions, or (ii) the United Nations Convention for Contracts for the International Sale of Goods, which is explicitly excluded. Any dispute arising from or in connection with the Data provided to you hereunder shall be submitted to the Shanghai International Economic and Trade Arbitration Commission for arbitration.

## **Gracenote® Copyright**

CD and music-related data from Gracenote, Inc., copyright©

2000-2007 Gracenote. Gracenote Software, copyright © 2000-2007 Gracenote. This product and service may practice one or more of the following U.S. Patents 5,987,525; 6,061,680; 6,154,773; 6,161,132; 6,230,192; 6,230,207; 6,240,459; 6,330,593 and other patents issued or pending. Some services supplied under license from Open Globe, Inc. for U.S. Patent 6,304,523.

Gracenote and CDDB are registered trademarks of Gracenote. The Gracenote logo and logotype, and the "Powered by Gracenote™" logo are trademarks of Gracenote.

## **Gracenote® End User License Agreement (EULA)**

This device contains software from Gracenote, Inc. of 2000 Powell Street Emeryville, California 94608 ("Gracenote").

The software from Gracenote (the "Gracenote Software") enables this device to do disc and music file identification and obtain music-related information, including name, artist, track, and title information ("Gracenote Data") from online servers ("Gracenote Servers"), and to perform other functions. You may use Gracenote Data only by means of the intended End User functions of this device. This device may contain content belonging to Gracenote's providers. If so, all of the restrictions set forth herein with respect to Gracenote Data shall also apply to such content and such content providers shall be entitled to all of the benefits and protections set forth herein that are available to Gracenote. You agree that you will use the content from Gracenote ("Gracenote Content"), Gracenote Data, the Gracenote Software, and Gracenote Servers for your own personal, non-commercial use only. You agree not to assign, copy, transfer or transmit the Gracenote Content, Gracenote Software

# Appendices

---

or any Gracenote Data (except in a Tag associated with a music file) to any third party. YOU AGREE NOT TO USE OR EXPLOIT GRACENOTE CONTENT, GRACENOTE DATA, THE GRACENOTE SOFTWARE, OR GRACENOTE SERVERS, EXCEPT AS EXPRESSLY PERMITTED HEREIN.

You agree that your non-exclusive licenses to use the Gracenote Content, Gracenote Data, the Gracenote Software, and Gracenote Servers will terminate if you violate these restrictions. If your licenses terminate, you agree to cease any and all use of the Gracenote Content, Gracenote Data, the Gracenote Software, and Gracenote Servers.

Gracenote, respectively, reserve all rights in Gracenote Data, the Gracenote Software, and the Gracenote Servers and Gracenote Content, including all ownership rights. Under no circumstances will either Gracenote become liable for any payment to you for any information that you provide, including any copyrighted material or music file information. You agree that Gracenote may enforce its respective rights, collectively or separately, under this agreement against you, directly in each company's own name.

Gracenote uses a unique identifier to track queries for statistical purposes. The purpose of a randomly assigned numeric identifier is to allow Gracenote to count queries without knowing anything about who you are. For more information, see the web page at [www.gracenote.com](http://www.gracenote.com) for the Gracenote Privacy Policy.

THE GRACENOTE SOFTWARE, EACH ITEM OF GRACENOTE DATA AND THE GRACENOTE CONTENT ARE LICENSED TO YOU "AS IS". NEITHER GRACENOTE MAKES ANY REPRESENTATIONS OR WARRANTIES, EXPRESS OR IMPLIED, REGARDING THE ACCURACY OF ANY GRACENOTE DATA FROM THE

GRACENOTE SERVERS OR GRACENOTE CONTENT. GRACENOTE COLLECTIVELY AND SEPARATELY RESERVE THE RIGHT TO DELETE DATA AND/OR CONTENT FROM THE COMPANIES' RESPECTIVE SERVERS OR, IN THE CASE OF GRACENOTE, CHANGE DATA CATEGORIES FOR ANY CAUSE THAT GRACENOTE DEEMS SUFFICIENT. NO WARRANTY IS MADE THAT EITHER GRACENOTE CONTENT OR THE GRACENOTE SOFTWARE OR GRACENOTE SERVERS ARE ERROR-FREE OR THAT THE FUNCTIONING OF THE GRACENOTE SOFTWARE OR GRACENOTE SERVERS WILL BE UNINTERRUPTED. GRACENOTE IS NOT OBLIGATED TO PROVIDE YOU WITH ANY ENHANCED OR ADDITIONAL DATA TYPES THAT GRACENOTE MAY CHOOSE TO PROVIDE IN THE FUTURE AND IS FREE TO DISCONTINUE ITS ONLINE SERVICES AT ANY TIME. GRACENOTE DISCLAIMS ALL WARRANTIES EXPRESS OR IMPLIED, INCLUDING, BUT NOT LIMITED TO, IMPLIED WARRANTIES OF MERCHANTABILITY, FITNESS FOR A PARTICULAR PURPOSE, TITLE, AND NON-INFRINGEMENT. NEITHER GRACENOTE WARRANTS THE RESULTS THAT WILL BE OBTAINED BY YOUR USE OF THE GRACENOTE SOFTWARE OR ANY GRACENOTE SERVER. IN NO CASE WILL GRACENOTE BE LIABLE FOR ANY CONSEQUENTIAL OR INCIDENTAL DAMAGES OR FOR ANY LOST PROFITS OR LOST REVENUES FOR ANY REASON WHATSOEVER. © Gracenote 2007.

## **Radio Frequency Statement**

FCC ID: ACJ-SYNCG3-L

IC: 216B-SYNCG3-L

This device complies with Part 15 of the FCC Rules and with RSS-210 of Industry Canada. Operation is subject to the following two conditions:

# Appendices

(1) This device may not cause harmful interference, and

(2) this device must accept any interference received, including interference that may cause undesired operation.



**WARNING:** Changes or modifications not expressly approved by the party responsible for compliance could void the user's authority to operate the equipment. The term "IC:" before the radio certification number only signifies that Industry Canada technical specifications were met.

The antenna used for this transmitter must not be co-located or operating in conjunction with any other antenna or transmitter.

## Taiwan Territory

Note: In accordance with the management approach of low-power radio wave radiation motors:

Article 12: For approved and certified low-power radiation motor models, companies, firms or users must not alter the frequency, increase the power or change the characteristics and functions of the original design without authorization.

Article 14: The usage of low-power radio-frequency motors must not affect aviation safety and interfere with legal telecommunications. Should interference be detected, immediately stop using the device and only resume use after ensuring that there is no longer any interference. For the legal telecommunication and wireless telecommunication of the telco, the low-power radio frequency motor must be able to tolerate legal limits of interference from telecommunication, industrial, scientific and radio wave equipment.

## SUNA TRAFFIC CHANNEL – TERMS AND CONDITIONS

By activating, using and/or accessing the SUNA Traffic Channel, SUNA Predictive or other content or material provided by Intelematics (together, **SUNA Products and/or Services**), you must accept certain terms and conditions. The following is a brief summary of the terms and conditions that apply to you. To view the full terms and conditions relevant to your use of the SUNA Products and/or Services, please consult:

Website
<a href="http://www.sunattraffic.com.au/termsandconditions/">www.sunattraffic.com.au/termsandconditions/</a>

### 1. Acceptance

By using SUNA Products and/or Services, you will be deemed to have accepted and agreed to be bound by the terms and conditions fully detailed at:

Website
<a href="http://www.sunattraffic.com.au/termsandconditions/">www.sunattraffic.com.au/termsandconditions/</a>

### 2. Intellectual Property

SUNA Products and/or Services are for your personal use. You may not record, or retransmit the content, nor use the content in association with any other traffic information or route guidance service or device not approved by Intelematics. You obtain no right of ownership in any Intellectual Property Rights (including copyright) in the data that is used to provide SUNA Products and/or Services.

### 3. Appropriate Use

# Appendices

---

SUNA Products and/or Services are intended as an aid to personal motoring and travel planning, and do not provide comprehensive or accurate information on all occasions. On occasions, you may experience additional delay as a result of using SUNA Products and/or Services. You acknowledge that it is not intended, or suitable, for use in applications where time of arrival or driving directions may impact the safety of the public or yourself.

## **4. Use of SUNA Products and Services while driving**

You, and other authorised drivers of the vehicle in which SUNA Products and/or Services are available or installed and active, remain at all times responsible for observing all relevant laws and codes of safe driving. In particular, you agree to only actively operate SUNA Products and/or Services when the Vehicle is at a complete stop and it is safe to do so.

## **5. Service Continuity and Reception of the SUNA Traffic Channel**

We will use reasonable endeavours to provide the SUNA Traffic Channel 24 hours a day, 365 days a year. The SUNA Traffic Channel may occasionally be unavailable for technical reasons or for planned maintenance. We will try to perform maintenance at times when congestion is light. We reserve the right to withdraw SUNA Products and/or Services at any time.

Also, we cannot assure the uninterrupted reception of the SUNA Traffic Channel RDS-TMC signal at any particular location.

## **6. Limitation of Liability**

Neither Intelematics (nor its suppliers or the manufacturer of your device (the “**Suppliers**”)) shall be liable to you or to any third party for any damages either direct, indirect, incidental, consequential or otherwise arising out of the use of or inability to use SUNA Products and/or

Services even if Intelematics or a Supplier has been advised of the possibility of such damages. You also acknowledge that the neither Intelematics nor any Supplier guarantees nor make any warranties that relate to the availability, accuracy or completeness of SUNA Products and/or Services, and to the extent which it is lawful to do so, both Intelematics and each Supplier excludes any warranties which might otherwise be implied by any State or Federal legislation in relation to SUNA Products and/or Services.

## **7. Please Note**

Great care has been taken in preparing this manual. Constant product development may mean that some information is not entirely up-to-date. The information in this document is subject to change without notice.

## **DECLARATION OF CONFORMITY**

Your vehicle could have components that transmit and receive radio waves and are therefore subject to European directive 2014/53/EU.

Our suppliers have declared that their components conform with European directive 2014/53/EU. For the full text of their declaration, visit [www.wirelessconformity.ford.com](http://www.wirelessconformity.ford.com).



# Index

## A

A/C	
See: Climate Control.....	95
About This Manual.....	7
ABS	
See: Brakes.....	163
ABS driving hints	
See: Hints on Driving With Anti-Lock Brakes.....	163
Accessories	
See: Replacement Parts Recommendation.....	12
ACC	
See: Using Adaptive Cruise Control.....	186
Active Park Assist.....	175
Using Active Park Assist.....	176
Adjusting the Steering Wheel.....	59
Air Conditioning	
See: Climate Control.....	95
Alarm	
See: Anti-Theft Alarm.....	57
AM/FM Radio - Vehicles Without: SYNC 3.....	304
Selecting a Radio Source.....	304
Anti-Theft Alarm.....	57
Alarm System.....	57
Arming the Alarm.....	58
Disarming the Alarm.....	58
Full Guard and Reduced Guard.....	58
Triggering the Alarm.....	57
Appendices.....	343
Apps.....	324
Using Apps on an Android Device.....	325
Using Apps on an iOS Device.....	324
At a Glance.....	15
Audible Warnings and Indicators - Automatic Transmission.....	79
Automatic Transmission Warning Chime.....	79
Headlamps On Warning Chime.....	79
Parking Brake On Warning Chime.....	79
Audible Warnings and Indicators - Manual Transmission.....	79
Headlamps On Warning Chime.....	79
Parking Brake On Warning Chime.....	79
Audio System.....	301
Audio Unit Clock and Date Displays - Vehicles Without: SYNC 3.....	306
Adjusting the Clock.....	306
Audio Unit - Vehicles With: SYNC 3.....	303
Adjusting the Volume.....	304
Changing Radio Stations.....	304
Pausing or Playing Media.....	304
Seek Down and Previous Track Button.....	304
Seek Up and Next Track Button.....	304
Sound Settings.....	304
Switching the Audio Unit On and Off.....	303
Switching the Screen On and Off.....	304
Audio Unit - Vehicles Without: SYNC 3.....	301
Adjusting the Volume.....	301
Changing Radio Stations.....	301
Pausing or Playing Media.....	303
Returning to the Previous Screen.....	303
Scrolling Through the Menu Options.....	302
Seek Down and Previous Track Button.....	303
Seek Up and Next Track Button.....	303
Selecting a Menu Option.....	303
Selecting Media.....	302
Selecting the Radio.....	301
Sound Settings.....	303
Switching the Audio Unit On and Off.....	301
Switching the Screen On and Off.....	303
System Settings.....	303
Using a Cell Phone.....	303
Autolamps.....	64
Windshield Wiper Activated Headlamps.....	65
Automatic Climate Control.....	96
Directing Air to the Footwell Air Vents.....	97
Directing Air to the Instrument Panel Air Vents.....	97
Directing Air to the Windshield Air Vents.....	97
Setting the Blower Motor Speed.....	97
Setting the Temperature.....	97
Switching Auto Mode On and Off.....	96
Switching Maximum Cooling On and Off.....	96
Switching Maximum Defrost On and Off.....	96

# Index

Switching the Air Conditioning On and Off.....	96
Switching the Climate Control On and Off.....	96
Switching the Recirculated Air On and Off.....	96
Automatic Crash Notification System.....	34
Automatic High Beam Control.....	65
About Automatic High Beam Control.....	66
Automatic High Beam Control Information Messages.....	67
Automatic High Beam Indicator.....	66
Overriding Automatic High Beam Control.....	66
Switching Automatic High Beam Control On or Off.....	66
Automatic Transmission.....	160
Brake Shift Interlock.....	161
Selector Lever Positions.....	160
SelectShift™.....	161
Automatic Transmission Fluid Check.....	247
Auto-Start-Stop - Automatic Transmission.....	138
Information Messages.....	139
Principle of Operation.....	138
Replacing the Battery.....	139
Switching the System On and Off.....	139
Using Auto-Start-Stop.....	138
Auto-Start-Stop - Manual Transmission.....	139
Auto-Start-Stop Warning.....	140
Information Messages.....	141
Principle of Operation.....	139
Replacing the Battery.....	141
Switching the System On and Off.....	140
Using Auto-Start-Stop.....	140
Autowipers.....	60
Settings.....	61
Auxiliary Heater.....	99
Parking Heater.....	100
Principle of Operation.....	99
Using the Auxiliary Heater.....	99
Auxiliary Power Points.....	118
12 Volt DC Power Point.....	118

## B

Battery	
See: Changing the 12V Battery.....	249
Blind Spot Information System.....	200
.....	201
Switching the System On and Off.....	202
System Errors.....	202
Using the Blind Spot Information System.....	201
BLIS	
See: Blind Spot Information System.....	200
Bonnet Lock	
See: Opening and Closing the Hood.....	240
Brake Fluid Check.....	248
Brakes.....	163
General Information.....	163
Breaking-In.....	224
Brakes and Clutch.....	224
Engine.....	224
Tires.....	224
Bulb Specification Chart.....	292

## C

Capacities and Specifications - 1.0L	
EcoBoost™.....	287
Air Conditioning System.....	287
Brake System.....	289
Engine.....	288
Fuel Tank.....	289
Washer Reservoir.....	289
Capacities and Specifications - 1.5L	
EcoBlue.....	290
Air Conditioning System.....	290
Brake System.....	292
Diesel Exhaust Fluid (AdBlue) Tank.....	291
Engine.....	290
Fuel Tank.....	291
Washer Reservoir.....	292
Capacities and Specifications.....	282
Cargo Nets.....	215
Installing the Net.....	215
Removing the Net.....	217
Car Wash	
See: Cleaning the Exterior.....	256
Catalytic Converter - Gasoline.....	149
On-Board Diagnostics System.....	149

# Index

Changing a Bulb.....	250	Cleaning the Exterior.....	256
Cargo Area Lamp.....	254	Body Paintwork Preservation.....	257
Central High Mounted Brake Lamp.....	253	Cleaning Stripes or Graphics.....	256
Direction Indicator.....	251	Cleaning the Chrome Trim.....	256
Front Fog Lamps.....	253	Cleaning the Headlamps.....	256
Front Interior Lamp.....	253	Cleaning the Rear Window.....	256
Front Interior LED Lamps.....	254	Cleaning the Interior.....	257
Headlamp.....	251	Fabric, Carpets, Cloth Seats, Headliners and Floor Mats.....	257
Headlamp High Beam.....	252	Instrument Cluster Screens, LCD Screens and Radio Screens.....	258
Headlamp Low Beam.....	252	Leather Interior.....	258
License Plate Lamp.....	253	Mirrors.....	258
Reading Lamps.....	254	Rear Windows.....	258
Rear Lamps.....	253	Seatbelts.....	257
Side Direction Indicator.....	252	Storage Compartments, Cup Holders and Ashtrays.....	259
Side Lamp.....	251	Suede Micro Fiber Fabric.....	258
Changing a Fuse.....	238	Cleaning the Wheels.....	259
Fuse Types.....	238	Clearing All MyKeys.....	41
General Information.....	238	MyKey Information Messages.....	41
Passenger Compartment Fuse Box.....	238	Climate Control.....	95
Trailer Tow Module Fuse Box.....	238	Clutch Fluid Check - Manual Transmission.....	248
Changing a Road Wheel.....	270	Cold Weather Precautions.....	225
Installing a Road Wheel.....	275	Connecting a Bluetooth Device - Vehicles Without: SYNC 3.....	306
Jacking and Lifting Points.....	271	Pairing a Device.....	306
Lowering the Spare Wheel.....	273	Connecting the Vehicle to a Mobile Network.....	296
Lug Nuts.....	270	About the Modem.....	296
Removing a Road Wheel.....	274	Enabling the Modem Using FordPass.....	296
Removing the Wheel Trim.....	274	Coolant Check See: Engine Coolant Check.....	246
Stowing the Flat Tire.....	275	Cornering Lamps.....	68
Vehicle Jack.....	271	Creating a MyKey - Vehicles With: Push Button Start.....	38
Vehicles with a Spare Wheel.....	270	MyKey Information Messages.....	39
Changing the 12V Battery.....	249	Creating a MyKey - Vehicles Without: Push Button Start.....	38
Changing the Front Wiper Blades.....	249	MyKey Information Messages.....	38
Changing the Rear Wiper Blades - Vehicles With: Manual Liftgate.....	250	Creating a Wi-Fi Hotspot - Vehicles Without: SYNC 3.....	299
Changing the Rear Wiper Blades - Vehicles With: Rear Cargo Doors.....	250	Connecting a Device to the Wi-Fi Hotspot.....	299
Changing the Wi-Fi Hotspot Name or Password - Vehicles Without: SYNC 3.....	299	Finding the Wi-Fi Hotspot Name and Password.....	299
Checking MyKey System Status.....	41		
Checking the Wiper Blades.....	249		
Child Restraint Positioning.....	22		
Child Safety.....	18		
Child Safety Locks.....	26		
Left-Hand Side.....	26		
Right-Hand Side.....	26		
Cigar Lighter.....	118		

# Index

Cross Traffic Alert.....	202
False Alerts.....	205
Switching the System Off and On.....	205
System Errors.....	205
System Lights, Messages and Audible Alerts.....	204
System Limitations.....	204
Using the System.....	202
Cruise Control.....	185
Principle of Operation.....	185
Cruise control	
See: Using Cruise Control.....	185
Cup Holders.....	120
<b>D</b>	
Data Recording.....	9
Comfort, Convenience and Entertainment Data.....	11
Event Data.....	10
Service Data.....	10
Services That Third Parties Provide.....	11
Services That We Provide.....	11
Vehicles With a Modem.....	11
Vehicles With SYNC.....	12
Declaration of Conformity.....	369
Diesel Particulate Filter.....	154
Diesel Particulate Filter Automatic Regeneration.....	155
Diesel Particulate Filter Manual Regeneration.....	156
On-Board Diagnostics System.....	155
Digital Radio - Vehicles Without: SYNC 3.....	305
Selecting a Radio Source.....	305
Direction Indicators.....	69
Doors and Locks.....	49
Driver Airbag.....	30
Driver Alert.....	194
Driver Alert System Display.....	195
Driver Alert System Messages.....	196
Driver Alert System Warnings.....	195
Switching Driver Alert On or Off.....	196
Driving Aids.....	192
Driving Hints.....	224
Driving Through Water.....	225

## E

Eco Mode.....	208
Eco Mode System Display.....	208
Principle of Operation.....	208
Economical Driving.....	224
EcoSelect.....	141
About EcoSelect.....	141
EcoSelect Indicator.....	141
Switching EcoSelect On and Off.....	141
Electromagnetic Compatibility.....	343
Emergency Assistance.....	34
End User License Agreement.....	345
VEHICLE SOFTWARE END USER LICENSE AGREEMENT (EULA) .....	345
Engine Block Heater.....	136
Using the Engine Block Heater.....	137
Engine Coolant Check.....	246
Adding Coolant.....	247
Engine Cooling Fan - Diesel.....	246
Engine Cooling Fan - Gasoline.....	246
Engine Emission Control.....	149
Engine Immobilizer	
See: Passive Anti-Theft System.....	57
Engine Oil Check.....	245
Adding Engine Oil.....	245
Engine Oil Dipstick - 1.0L EcoBoost™.....	245
Engine Oil Dipstick - 1.5L Duratorq-TDCi Diesel.....	245
Entertainment.....	316
Playing Music From a USB or Media Player.....	317
Streaming Music From a Bluetooth Device.....	317
Using the Radio.....	316
Environment.....	14
Event Data Recording	
See: Data Recording.....	9
Exterior Mirrors.....	72
Adjusting the Mirrors.....	72
Folding the Mirrors.....	73

## F

Fan	
See: Engine Cooling Fan - Diesel.....	246
See: Engine Cooling Fan - Gasoline.....	246

# Index

Fastening the Seatbelts.....	27
Using Seatbelts During Pregnancy.....	27
First Aid Kit.....	227
Flat Tire	
See: Changing a Road Wheel.....	270
Flat Tire Inflation	
See: Tire Sealant and Inflator Kit.....	260
Floor Mats.....	225
Fog Lamps - Front	
See: Front Fog Lamps.....	67
Fog Lamps - Rear	
See: Rear Fog Lamps.....	67
Folding Bulkhead.....	218
Moving the Folding Bulkhead to the Forward Position.....	218
Folding Tray.....	120
Front Fog Lamps.....	67
Front Fog Lamp Indicator.....	67
Switching the Front Fog Lamps On or Off.....	67
Front Parking Aid.....	171
Front Parking Aid Information Messages.....	173
Object Distance Indicator.....	172
Front Wiper Blades	
See: Changing the Front Wiper Blades.....	249
Fuel and Refueling.....	142
Fuel Burning Heater	
See: Auxiliary Heater.....	99
Fuel Consumption Figures - 1.0L	
EcoBoost™.....	294
Fuel Consumption Figures - 1.5L	
EcoBlue.....	295
Fuel Consumption Figures.....	294
European Directive 1999/94/EC.....	294
Fuel Economy and CO2 Emissions.....	294
World Harmonised Light Vehicle Test Procedure.....	294
Fuel Consumption.....	148
Advertised Capacity.....	148
Fuel Economy.....	148
Fuel Filler Funnel Location.....	143
Fuel Quality - Diesel.....	143
Long-Term Storage.....	143
Fuel Quality - Gasoline.....	142
Long-Term Storage.....	143
Fuel Shutoff.....	227
Ignition Switch.....	227
Keyless Starting.....	227
Fuse Box Locations.....	232
Engine Compartment Fuse Box.....	232
Passenger Compartment Fuse Box.....	232
Trailer Tow Module.....	232
Fuses.....	232
Fuse Specification Chart.....	233
Engine Compartment Fuse Box.....	233
Passenger Compartment Fuse Box.....	236
Trailer Tow Module Fuse Box.....	238
<b>G</b>	
Gasoline Particulate Filter.....	153
Gasoline Particulate Filter Information Messages.....	154
Gasoline Particulate Filter Regeneration.....	153
Gasoline Particulate Filter Warning Lamps and Indicators.....	153
Gauges.....	75
Engine Coolant Temperature Gauge.....	76
Fuel Gauge.....	75
Information Display.....	75
Gearbox	
See: Transmission.....	160
General Information on Radio Frequencies.....	44
Global Opening and Closing.....	72
Global Closing.....	72
Global Opening.....	72
<b>H</b>	
Handbrake	
See: Parking Brake - Automatic Transmission.....	164
See: Parking Brake - Manual Transmission.....	163
Hazard Flashers.....	227
Hazard Flasher Indicator.....	227
Switching the Hazard Flashers On or Off.....	227
Headlamp Exit Delay.....	65
Headlamp Leveling.....	68
Headrest	
See: Head Restraints.....	105

# Index

Head Restraints.....	105	Switching the Ignition to Accessory Mode.....	122
Adjusting the Head Restraints.....	105	Information Displays.....	80
Removing the Head Restraints.....	106	General Information.....	80
Heated Exterior Mirrors.....	99	Information Messages.....	82
Heated Rear Window.....	99	Active Park Assist.....	82
Heated Seats.....	116	Adaptive Cruise Control.....	83
Heated Windshield.....	99	Alarm.....	83
Heating		Automatic High Beam Control.....	84
See: Climate Control.....	95	Auto-Start-Stop.....	84
Hill Start Assist.....	164	Blind Spot Information and Cross Traffic Alert Systems.....	85
Switching the System On and Off.....	165	Brake System.....	85
Using Hill Start Assist.....	165	Doors and Locks.....	86
Hints on Controlling the Interior Climate - Vehicles With: Automatic Temperature Control.....	97	Driver Alert.....	86
Defogging or Clearing the Windshield of Thin Ice.....	98	Engine.....	86
Defogging the Side Windows in Cold Weather.....	98	Fuel System.....	87
General Hints.....	97	Headlamps.....	87
Quickly Cooling the Interior.....	98	Hill Start Assist.....	87
Recommended Settings for Cooling.....	98	Lane Keeping System.....	87
Recommended Settings for Heating.....	98	Maintenance.....	88
Hints on Controlling the Interior Climate - Vehicles With: Manual Temperature Control.....	98	MyKey.....	89
Defogging or Clearing the Windshield of Thin Ice.....	99	Parking Aid.....	89
Defogging the Side Windows in Cold Weather.....	99	Parking Brake.....	90
General Hints.....	98	Parking Heater.....	90
Quickly Cooling the Interior.....	99	Pre-Collision Assist.....	90
Quickly Heating the Interior.....	98	Rear Window Lock.....	90
Recommended Settings for Cooling.....	99	Remote Control.....	90
Recommended Settings for Heating.....	98	Seatbelt Reminder.....	91
Hints on Driving With Anti-Lock Brakes.....	163	Selective Catalytic Reductant System.....	91
Home Screen.....	311	Stability Control.....	92
Hood Lock		Starting System.....	92
See: Opening and Closing the Hood.....	240	Steering System.....	93
		Tire Pressure Monitoring System.....	93
		Transmission.....	94
		Wireless Accessory Charging.....	94
		Installing Child Restraints.....	18
		Attaching a Child Restraint With a Support Leg.....	21
		Attaching a Child Restraint With Top Tethers.....	21
		Booster Seats.....	19
		Child Restraints for Different Mass Groups.....	19
		ISOFIX Anchor Points.....	20
		Top Tether Anchor Points.....	21
Ignition Switch.....	122	Instrument Cluster.....	75
Starting the Engine.....	123	Instrument Lighting Dimmer.....	65
Switching the Ignition Off.....	122		
Switching the Ignition On.....	123		

# Index

Instrument Panel Overview - LHD.....	16
Instrument Panel Overview - RHD.....	15
Instrument Panel Storage Compartment.....	121
Intelligent Speed Limiter.....	193
Principle of Operation.....	193
Using Intelligent Speed Limiter.....	193
Interior Lamps.....	69
Courtesy Lamp.....	69
Reading Lamps.....	70
Interior Mirror - Vehicles With: Auto-Dimming Interior Mirror.....	73
Interior Mirror - Vehicles Without: Auto-Dimming Interior Mirror.....	73
Introduction.....	7
<b>J</b>	
Jump Starting the Vehicle.....	228
Connecting the Jumper Cables.....	228
Jump Starting.....	229
Preparing Your Vehicle.....	228
Removing the Jumper Cables.....	229
<b>K</b>	
Keyless Entry.....	53
Disabled Keys.....	54
General Information.....	53
Locking and Unlocking the Doors with the Key Blade.....	55
Locking Your Vehicle.....	53
Passive Key.....	53
Unlocking Your Vehicle.....	54
Keys and Remote Controls.....	44
<b>L</b>	
Lane Keeping System.....	196
Lane Keeping System Display.....	199
Lane Keeping System Messages.....	200
Lane Keeping System Settings.....	197
Lane Keeping System Warning Lamps and Indicators.....	199
Switching Lane Keeping System On or Off.....	197
Liftgate.....	56
Lighting Control.....	63
Headlamp Flasher.....	64
Headlamp High Beam.....	64
Home Safe Lighting.....	64
Lighting Control Positions.....	63
Parking Lamps.....	63
Lighting.....	63
General Information.....	63
Load Carriers See: Roof Racks and Load Carriers.....	217
Load Carrying.....	214
General Information.....	214
Locking and Unlocking.....	49
Automatic Locking.....	52
Automatic Re-Locking.....	52
Automatic Unlocking.....	52
Configurable Unlocking.....	52
Double Locking.....	49
Locking.....	49
Locking and Unlocking Confirmation.....	50
Locking and Unlocking the Doors From Inside.....	50
Locking the Doors Individually With the Key.....	51
One-Stage Unlocking.....	52
Opening the Double Rear Doors.....	50
Opening the Sliding Door.....	50
Rear Emergency Exit.....	51
Two-Stage Unlocking.....	52
Unlocking.....	49
Luggage Anchor Points.....	214
Lug Nuts See: Changing a Road Wheel.....	270
Lug Nuts.....	281
Locking Lug Nuts.....	281
Lug Nut Torque.....	281
<b>M</b>	
Maintenance.....	240
General Information.....	240
Manual Climate Control.....	95
Directing Air to the Footwell Air Vents.....	95
Directing Air to the Instrument Panel Air Vents.....	95
Directing Air to the Windshield Air Vents.....	95
Setting the Blower Motor Speed.....	95

# Index

Setting the Temperature.....	96
Switching Maximum Cooling On and Off.....	95
Switching Maximum Defrost On and Off.....	95
Switching the Air Conditioning On and Off.....	95
Switching the Climate Control On and Off.....	95
Switching the Recirculated Air On and Off.....	95
Manual Liftgate.....	56
Closing the Liftgate.....	56
Opening the Liftgate.....	56
Unlocking the Liftgate.....	56
Manual Seats.....	107
Adjusting the Lumbar Support.....	108
Adjusting the Seat Backrest.....	107
Adjusting the Seat Height.....	107
Dual Passenger Seat.....	109
Moving the Seat Backward and Forward.....	107
Single Passenger Seat.....	108
Manual Transmission.....	160
General Information.....	160
Shifting Into Reverse Gear.....	160
Message Center	
See: Information Displays.....	80
Mirrors	
See: Windows and Mirrors.....	71
Mobile Communications Equipment.....	13
MyKey Settings.....	37
Configurable Settings.....	37
Non-Configurable Settings.....	37
MyKey – Troubleshooting - Vehicles	
With: Push Button Start.....	42
What is an admin key?.....	42
Why can I not clear the MyKeys?.....	42
Why can I not create a MyKey?.....	42
Why can I not program a MyKey?.....	42
Why can I not start the engine with a MyKey?.....	43
Why does the MyKey distance not accumulate?.....	43
MyKey – Troubleshooting - Vehicles	
Without: Push Button Start.....	42
What is an admin key?.....	42
Why can I not clear the MyKeys?.....	42
Why can I not create a MyKey?.....	42
Why can I not program a MyKey?.....	42
Why does the MyKey distance not accumulate?.....	42
MyKey™.....	37
Principle of Operation.....	37
<b>N</b>	
Navigation.....	320
Changing the Format of the Map.....	321
Live Traffic.....	323
Michelin Travel Guide.....	324
Navigation Map Updates.....	324
Route Guidance.....	322
Setting a Destination.....	320
Zoom.....	321
Network Connectivity.....	296
Connecting the Vehicle to a Mobile Network.....	296
Network Connectivity – Troubleshooting.....	297
<b>O</b>	
Oil Change Indicator Reset.....	246
Resetting the Oil Life Monitoring System.....	246
Oil Check	
See: Engine Oil Check.....	245
Opening and Closing the Hood.....	240
Closing the Hood.....	241
Opening the Hood.....	240
Overhead Console.....	120
Rear Door Storage Compartment.....	120
<b>P</b>	
Parking Aids.....	169
Principle of Operation.....	169
Parking Brake - Automatic Transmission.....	164
Parking Brake - Manual Transmission.....	163
Passenger Airbag.....	31
Passive Anti-Theft System.....	57
Arming the Engine Immobilizer.....	57
Coded Keys.....	57

# Index

Disarming the Engine Immobilizer.....	57
Principle of Operation.....	57
Passive Key Backup Position.....	48
PATS	
See: Passive Anti-Theft System.....	57
Personalized Settings.....	82
Measure Units.....	82
Switching Chimes Off.....	82
Phone.....	318
Android Auto.....	320
Apple CarPlay.....	319
Pairing Your Cell Phone for the First Time.....	318
Text Messaging.....	319
Using Your Cell Phone.....	319
Playing Media From a USB Device - Vehicles Without: SYNC 3.....	306
Selecting the USB Device.....	307
Supported Audio File Formats.....	306
Power Door Locks	
See: Locking and Unlocking.....	49
Power Windows - Vehicles With:	
One-Touch Open Driver Window.....	72
One-Touch Open.....	72
Power Windows - Vehicles With: Rear Power Windows .....	71
Bounce-Back.....	71
One-Touch Close.....	71
One-Touch Open.....	71
Rear Window Lock.....	71
Pre-Collision Assist.....	209
Distance Alert.....	210
Distance Indication.....	211
Pre-Collision Assist Information Messages.....	213
Pre-Collision Assist System Sensors.....	212
Pre-Collision Assist Warning Lamp.....	212
Programming a MyKey.....	39
Protecting the Environment.....	14
Puncture	
See: Changing a Road Wheel.....	270
Push Button Ignition Switch.....	123
Failure to Start - Vehicles with Manual Transmission.....	123
Fast Restart.....	125
Key Outside Vehicle Audible Warning.....	125
Starting System Information Messages.....	125
Starting The Engine - Vehicles with Automatic Transmission.....	123
Starting The Engine - Vehicles with Manual Transmission.....	123
Stopping the Engine When Your Vehicle is Moving - Vehicles with Automatic Transmission.....	124
Stopping the Engine When Your Vehicle is Moving - Vehicles with Manual Transmission.....	124
Stopping the Engine When Your Vehicle is Stationary - Vehicles with Automatic Transmission.....	124
Stopping the Engine When Your Vehicle is Stationary - Vehicles with Manual Transmission.....	124
Switching the Ignition On to Accessory Mode.....	123
Vehicles with a Diesel Engine.....	123

## R

Rear Fog Lamps.....	67
Rear Fog Lamp Indicator.....	67
Switching the Rear Fog Lamps On or Off.....	67
Rear Parking Aid.....	169
Object Distance Indicator.....	170
Rear Parking Aid Information Messages.....	171
Rear Seats - Long Wheelbase.....	113
Second Row Seats.....	114
Third Row Seats.....	115
Rear Seats - Short Wheelbase.....	111
Second Row Seats.....	111
Third Row Seats.....	112
Rear Under Floor Storage.....	215
Adjustable Load Floor.....	215
Passenger Compartment Floor.....	215
Rear View Camera.....	182
Rear View Camera Delay.....	184
Switching the Rear View Camera Off.....	184
Switching the Rear View Camera On.....	183
Using the Display.....	183
Vehicles With Parking Aid.....	184
Rear View Camera	
See: Rear View Camera.....	182

# Index

Rear Window Wiper and Washers.....	62
Rear Window Washer.....	62
Rear Window Wiper.....	62
Rear Wiper Blades	
See: Changing the Rear Wiper Blades - Vehicles With: Manual Liftgate.....	250
See: Changing the Rear Wiper Blades - Vehicles With: Rear Cargo Doors.....	250
Reduced Engine Performance.....	224
Refueling.....	145
Refueling System Overview.....	145
Refueling System Warning.....	147
Refueling Your Vehicle.....	146
Remote Control - Vehicles With: Keyless Entry and Push Button Start.....	44
Locating Your Vehicle.....	46
Removable Key Blade.....	44
Replacing the Battery.....	45
Remote Control - Vehicles With: Remote Flip Key.....	46
Locating Your Vehicle.....	48
Replacing the Battery.....	47
Remote Start.....	103
About Remote Start.....	103
Remotely Starting the Engine.....	103
Remotely Stopping the Engine.....	103
Remote Start Limitations.....	103
Remote Start Settings.....	103
Setting Remote Start to Active.....	103
Repairing Minor Paint Damage.....	259
Replacement Parts	
Recommendation.....	12
Collision Repairs.....	13
Scheduled Maintenance and Mechanical Repairs.....	12
Warranty on Replacement Parts.....	13
Replacing a Lost Key or Remote Control.....	48
Roadside Emergencies.....	227
Roof Racks and Load Carriers.....	217
Maximum Load Weights.....	218
Running-In	
See: Breaking-In.....	224
Running Out of Fuel.....	143
Adding Fuel From a Portable Fuel Container.....	144
Filling a Portable Fuel Container.....	144

## S

Safety Precautions.....	142
Seatbelt Height Adjustment.....	27
Seatbelt Reminder.....	28
Fasten Seatbelt Audible Warning.....	28
Fasten Seatbelt Warning Lamp.....	28
Seatbelt Status.....	28
Seatbelts.....	27
Seats.....	105
Security.....	57
Selective Catalytic Reductant System.....	149
Diesel Exhaust Fluid (AdBlue) Guidelines.....	150
Filling the Diesel Exhaust Fluid (AdBlue) Tank.....	150
Filling the Diesel Exhaust Fluid (AdBlue) Tank Using a Container.....	152
Filling the Diesel Exhaust Fluid Tank Using a Fuel Station Pump.....	151
Selective Catalytic Reductant System Warning Lamp.....	152
Settings.....	325
Apps.....	330
Bluetooth.....	327
Clock.....	327
Display.....	326
Emergency Assistance.....	329
General.....	325
Media Player.....	327
Modem.....	331
Navigation System.....	329
Phone.....	328
Radio.....	329
Sound.....	326
Valet Mode.....	332
Vehicle Settings.....	332
Voice Recognition.....	332
Wi-Fi.....	331
Side Airbags.....	32
Side Curtain Airbags.....	33
Side Sensing System.....	173
Object Distance Indicator.....	174
Sitting in the Correct Position.....	105
Sliding Door.....	53
Snow Chains	
See: Using Snow Chains.....	265

# Index

Spare Wheel	
See: Changing a Road Wheel.....	270
Special Notices.....	13
Speed Control	
See: Cruise Control.....	185
Speed Limiter.....	192
Principle of Operation.....	192
Using the System.....	192
Speed Sign Recognition.....	207
Principle of Operation.....	207
Speed Sign Recognition System	
Display.....	208
Using Speed Sign Recognition.....	207
Stability Control.....	167
Principle of Operation.....	167
Starter Switch	
See: Ignition Switch.....	122
Starting a Diesel Engine - Automatic	
Transmission.....	132
Engine Warning Lamps.....	133
Failure to Start.....	132
Glow Plug Indicator.....	133
Guarding Against Exhaust Fumes.....	133
Important Ventilating Information.....	133
Starting System Information	
Messages.....	134
Stopping the Engine When Your Vehicle is	
Moving.....	133
Stopping the Engine When Your Vehicle is	
Stationary.....	133
Vehicles with an Ignition Key.....	132
Vehicles with a Push Button Ignition	
Switch.....	132
Starting a Diesel Engine - Manual	
Transmission.....	134
Engine Warning Lamps.....	135
Failure to Start.....	134
Glow Plug Indicator.....	135
Guarding Against Exhaust Fumes.....	135
Important Ventilating Information.....	135
Starting System Information	
Messages.....	136
Stopping the Engine When Your Vehicle is	
Moving.....	135
Stopping the Engine When Your Vehicle is	
Stationary.....	135
Vehicles with an Ignition Key.....	134
Vehicles with a Push Button Ignition	
Switch.....	134
Starting a Gasoline Engine - Automatic	
Transmission.....	126
Automatic Engine Shutdown.....	127
Engine Warning Lamps.....	128
Failure to Start.....	127
Guarding Against Exhaust Fumes.....	128
Important Ventilating Information.....	128
Starting System Information	
Messages.....	129
Stopping the Engine When Your Vehicle is	
Moving.....	128
Stopping the Engine When Your Vehicle is	
Stationary.....	127
Vehicles with an Ignition Key.....	126
Vehicles with a Push Button Ignition	
Switch.....	126
Starting a Gasoline Engine - Manual	
Transmission.....	129
Automatic Engine Shutdown.....	130
Engine Warning Lamps.....	131
Failure to Start.....	129
Guarding Against Exhaust Fumes.....	131
Important Ventilating Information.....	131
Starting System Information	
Messages.....	132
Stopping the Engine When Your Vehicle is	
Moving.....	131
Stopping the Engine When Your Vehicle is	
Stationary.....	130
Vehicles with an Ignition Key.....	129
Vehicles with a Push Button Ignition	
Switch.....	129
Starting and Stopping the Engine.....	122
General Information.....	122
Steering Wheel Lock - Vehicles With:	
Push Button Start.....	126
Unlocking the Steering Wheel.....	126
Steering Wheel Lock - Vehicles Without:	
Push Button Start.....	126
Locking the Steering Wheel.....	126
Unlocking the Steering Wheel.....	126
Steering Wheel.....	59
Storage Compartments.....	120
Streaming Bluetooth Audio - Vehicles	
Without: SYNC 3.....	306
Selecting a Bluetooth Source.....	306

# Index

Sun Shades.....	74
Bounce-Back.....	74
Opening and Closing the Sun Shade.....	74
Sun Shade Relearning.....	74
Supplementary Restraints System.....	30
Principle of Operation.....	30
Switching Off the Engine.....	136
Vehicles With a Turbocharger.....	136
Switching the Passenger Airbag On and Off.....	31
Switching the Passenger Airbag Off.....	31
Switching the Passenger Airbag On.....	32
Symbols Glossary.....	7
SYNC™ 3.....	308
General Information.....	308
SYNC™ 3 Troubleshooting.....	333
Additional Information and Assistance.....	342
Apps.....	339
Navigation.....	338
Phone.....	337
Resetting the System.....	342
USB and Bluetooth Audio.....	334
Voice Recognition.....	333
Wi-Fi Connectivity.....	341
<b>T</b>	
Technical Specifications	
See: Capacities and Specifications.....	282
Tire Care.....	264
Tire Inflation When Punctured	
See: Tire Sealant and Inflator Kit.....	260
Tire Pressure Monitoring System.....	266
Changing Tires With a Tire Pressure Monitoring System.....	267
Changing Wheels With a Tire Pressure Monitoring System.....	267
Tire Pressure Monitoring System Reset Procedure.....	270
Understanding Your Tire Pressure Monitoring System.....	267
Tire Pressures.....	276
Spare Wheel.....	277
Tire Repair Kit	
See: Tire Sealant and Inflator Kit.....	260
Tire Sealant and Inflator Kit.....	260
After Using the Tire Sealant and Inflator Kit.....	264
Using the Tire Sealant and Inflator Kit.....	261
Tires	
See: Wheels and Tires.....	260
Towbar Dimensions.....	285
Towing a Trailer.....	221
Towing Points.....	230
Front Towing Point.....	230
Rear Towing Point.....	230
Towing Eye Location.....	230
Towing the Vehicle on Four Wheels - Automatic Transmission.....	223
Emergency Towing.....	223
Towing the Vehicle on Four Wheels - Manual Transmission.....	222
Towing.....	221
Traction Control.....	166
Principle of Operation.....	166
Traffic Sign Recognition.....	205
Principle of Operation.....	205
Traffic Sign Recognition System Display.....	206
Traffic Sign Recognition System Messages.....	207
Using Traffic Sign Recognition.....	206
Trailer Sway Control.....	222
Transmission.....	160
Trip Computer.....	82
Average Fuel.....	82
Digital Speedometer.....	82
Distance to Empty.....	82
Resetting the Trip Computer.....	82
Trip Odometer.....	82
<b>U</b>	
Under Hood Overview - 1.0L EcoBoost™.....	242
Under Hood Overview - 1.5L Duratorq-TDCi Diesel, LHD.....	243
Under Hood Overview - 1.5L Duratorq-TDCi Diesel, RHD.....	244
Under Seat Storage.....	121
Unique Driving Characteristics.....	138
USB Port.....	307

# Index

Using Adaptive Cruise Control.....	186	Vehicle Dimensions - Long Wheelbase	
Automatic Cancellation.....	189	Double Cab in Van, Transit.....	282
Blocked Sensor.....	190	Vehicle Dimensions.....	282
Canceling the Set Speed.....	189	Vehicle Dimensions - Long	
Changing the Set Speed.....	188	Wheelbase.....	283
Detection Issues.....	189	Vehicle Dimensions.....	283
Following a Vehicle.....	187	Vehicle Dimensions - Short Wheelbase	
Hilly Condition Usage.....	189	Com Kombi.....	283
Overriding the System.....	188	Vehicle Dimensions.....	283
Resuming the Set Speed.....	189	Vehicle Dimensions - Short Wheelbase	
Setting the Adaptive Cruise Speed.....	187	Double Cab in Van, Transit.....	284
Setting the Gap Distance.....	188	Vehicle Dimensions.....	284
Switching Adaptive Cruise Control		Vehicle Dimensions - Short	
Off.....	189	Wheelbase.....	284
Switching Adaptive Cruise Control		Vehicle Dimensions.....	284
On.....	186	Vehicle Identification Number.....	287
Switching to Normal Cruise Control.....	191	Vehicle Identification Plate.....	286
System Not Available.....	190	Ventilation	
Using Cruise Control.....	185	See: Climate Control.....	95
Switching Cruise Control Off.....	185	VIN	
Switching Cruise Control On.....	185	See: Vehicle Identification Number.....	287
Using MyKey With Remote Start		<b>W</b>	
Systems.....	42	Warning Lamps and Indicators.....	76
Using Snow Chains.....	265	Airbag Warning Lamp.....	76
Vehicles with Stability Control.....	265	Anti-Lock Brake System Warning	
Using Stability Control.....	168	Lamp.....	76
Using Traction Control.....	166	Auto-Start-Stop Indicator.....	76
Switching Traction Control On or Off.....	166	Battery Warning Lamp.....	76
Traction Control Indicator.....	166	Blind Spot Information System	
Traction Control Off Warning Lamp.....	166	Indicator.....	76
Using Voice Recognition.....	307	Brake System Warning Lamp.....	77
Apps.....	315	Cruise Control Indicator.....	77
Automatic Blower Motor Speed		Direction Indicator.....	77
Reduction.....	316	Engine Coolant Temperature Warning	
Entertainment.....	312	Lamp.....	77
General.....	311	Engine Warning Lamps.....	77
Navigation.....	314	Fasten Seatbelt Warning Lamp.....	77
Phone.....	313	Front Fog Lamp Indicator.....	77
Phone Voice Service.....	307	Frost Warning Lamp.....	77
Voice Settings.....	316	Glow Plug Indicator.....	78
Using Winter Tires.....	265	Headlamp High Beam Indicator.....	78
<b>V</b>		Ignition Warning Lamp.....	78
Vehicle Care.....	256	Lamps on Indicator.....	78
Vehicle Dimensions - Long Wheelbase		Low Fuel Level Warning Lamp.....	78
Com Kombi.....	282	Low Tire Pressure Warning Lamp.....	78
Vehicle Dimensions.....	282	Message Center Indicator.....	78

# Index

---

Oil Pressure Warning Lamp.....	78
Rear Fog Lamp Indicator.....	78
Shift Indicator.....	78
Stability Control and Traction Control Indicator.....	78
Stability Control and Traction Control Off Warning Lamp.....	79
Warning Triangle.....	227
Washer Fluid Check.....	248
Washers See: Cleaning the Exterior.....	256
Wheel Nuts See: Changing a Road Wheel.....	270
Wheels and Tires.....	260
General Information.....	260
Wi-Fi Hotspot.....	299
Windows and Mirrors.....	71
Windshield Washers.....	62
Windshield Wipers.....	60
Intermittent Wipe.....	60
Winter Tires See: Using Winter Tires.....	265
Wiper Blades See: Checking the Wiper Blades.....	249
Wipers and Washers.....	60
Wireless Accessory Charging.....	119



