

FORD **MUSTANG MACH-E** Owner's Manual



The information contained in this publication was correct at the time of release. In the interest of continuous development, we reserve the right to change specifications, design or equipment at any time without notice or obligation. No part of this publication may be reproduced, transmitted, stored in a retrieval system or translated into any language in any form by any means without our written permission. Errors and omissions excepted.

© Ford Motor Company 2022

All rights reserved.

Part Number: CG3920en-202209-20220923150538

Table of Contents

Introduction

About This Publication	15
Using This Publication	16

Symbols Glossary

Symbols Used on Your Vehicle	17
------------------------------------	----

Data Privacy

Data Privacy	20
Service Data	21
Event Data	21
Settings Data	22
Connected Vehicle Data	22
Mobile Device Data	22
Emergency Call System Data	23

Environment

Protecting the Environment	24
----------------------------------	----

Visual Search

Steering Wheel	25
Instrument Panel - LHD, Excluding: GT	26
Instrument Panel - RHD, Excluding: GT	27
Instrument Panel - GT, LHD	28
Instrument Panel - GT, RHD	29
Center Console - GT	30
Vehicle Interior - LHD, Excluding: GT	31
Vehicle Interior - RHD, Excluding: GT	32
Vehicle Interior - GT, LHD	33
Vehicle Interior - GT, RHD	34
Front Exterior - Excluding: GT	35
Front Exterior - GT	36
Rear Exterior - Excluding: GT	37
Rear Exterior - GT	38

Child Safety

Child Safety Precautions	39
Child Restraint Anchor Points	40
Child Restraints	41
Booster Seats	44
Child Safety Locks	45

Seatbelts

Seatbelt Precautions	46
Fastening and Unfastening the Seatbelts	46
Adjusting the Seatbelts During Pregnancy	46
Adjusting the Seatbelt Height	47
Seatbelt Reminder	47
Seatbelts – Troubleshooting	48

Airbags

How Do the Front Airbags Work	49
How Do the Side Airbags Work	49
How Do the Knee Airbags Work	50
How Does the Safety Canopy™ Work	50
Airbag Precautions	51
Switching the Passenger Airbag On and Off	52
Airbags – Troubleshooting	53

Pedestrian Protection

What Is Pedestrian Protection	54
How Does Pedestrian Protection Work	54
Pedestrian Protection Precautions	54
Pedestrian Protection Indicators	55

Pedestrian Alert System

What Is the Pedestrian Alert System	56
---	----

eCall

What Is eCall	57
---------------------	----

Table of Contents

How Does eCall Work	57
Emergency Call Requirements	57
Emergency Call Limitations	57
Manually Making an Emergency Call	57
Emergency Call Indicators	58
Changing the Backup Battery	59
eCall – Troubleshooting	59

Keys and Remote Controls

Remote Control Limitations	60
Using the Remote Control	60
Locating Your Vehicle	60
Changing the Remote Control Battery - LHD	60
Changing the Remote Control Battery - RHD	62
Replacing a Lost Key or Remote Control	64
Programming the Remote Control	64
Keys and Remote Controls – Troubleshooting	64

Phone as a Key

What Is Phone as a Key	65
Phone as a Key Limitations	65
Programming Your Phone	65
Using the Valet Mode	66
Using the Backup Start Passcode	66
Phone as a Key – Troubleshooting	67

MyKey™

What Is MyKey	69
MyKey Settings	69
Creating a MyKey	70
Programming a MyKey	71
Clearing All MyKeys	71
Checking MyKey System Status	71
MyKey – Troubleshooting	72

Doors and Locks

Operating the Doors From Outside Your Vehicle	74
Operating the Doors From Inside Your Vehicle	74
Autounlock	74
Autolock	75
Mislock	75
Doors and Locks Audible Warnings	75
Doors and Locks – Troubleshooting	75

Keyless Entry

What Is Keyless Entry	78
Keyless Entry Limitations	78
Keyless Entry Settings	78
Using Keyless Entry	78
Keyless Entry – Troubleshooting	79

Keyless Entry Keypad

What Is the Keyless Entry Keypad	80
Keyless Entry Keypad Limitations	80
Locating the Keyless Entry Keypad	80
Keyless Entry Keypad Master Access Code	80
Keyless Entry Keypad Personal Access Codes	80
Using the Keyless Entry Keypad	81
Keyless Entry Keypad – Troubleshooting	82

Walk Away Lock

What is Walk Away Lock	83
How Does Walk Away Lock Work	83
Walk Away Lock Limitations	83
Switching Walk Away Lock On and Off	83

Easy Entry and Exit

How Does Easy Entry and Exit Work	84
---	----

Table of Contents

Switching Easy Entry and Exit On and Off	84	Washers	102
		Wipers and Washers – Troubleshooting	103
Liftgate - Vehicles With: Hands-Free Liftgate/Power Liftgate		Exterior Lighting	
Liftgate Precautions	85	Exterior Lighting Control	104
Opening the Liftgate	85	Headlamps	104
Setting the Liftgate Opening Height	87	Headlamps – Troubleshooting	105
Closing the Liftgate	87	Autolamps	105
Stopping the Liftgate Movement	89	Exterior Lamps	106
Liftgate Obstacle Detection	89	Automatic High Beam Control	107
Liftgate – Troubleshooting	89	Automatic High Beam Control – Troubleshooting	109
		Glare Free Lighting	109
Liftgate - Vehicles With: Manual Liftgate		Glare Free Lighting – Troubleshooting	112
Opening the Liftgate	92	Adaptive Front Lighting	112
Closing the Liftgate	92		
Security		Interior Lighting	
Passive Anti-Theft System	94	Switching All of the Interior Lamps On and Off	113
Anti-Theft Alarm System	94	Switching the Front Interior Lamps On and Off	113
Anti-Theft Alarm System Settings	95	Switching the Rear Interior Lamps On and Off	113
Security – Troubleshooting	96	Interior Lamp Function	113
		Adjusting the Instrument Panel Lighting Brightness	114
Steering Wheel		Ambient Lighting	114
Adjusting the Steering Wheel	98	Interior Lighting – Troubleshooting	114
Horn	98		
Switching the Heated Steering Wheel On and Off	98	Windows	
		Opening and Closing the Windows	115
Wipers and Washers		Global Opening and Closing	115
Wipers	99	Window Bounce-Back	116
Autowipers	99	Locking the Rear Window Controls	116
Switching the Rear Window Wiper On and Off	100		
Reverse Wipe	100	Interior Mirror	
Checking the Wiper Blades	101	Interior Mirror Precautions	118
Replacing the Front Wiper Blades	101	Auto-Dimming Interior Mirror	118
Replacing the Rear Wiper Blades	101		

Table of Contents

Exterior Mirrors

Adjusting the Exterior Mirrors	119
Folding the Exterior Mirrors - Vehicles With: Power Folding Mirrors	119
Folding the Exterior Mirrors - Vehicles With: Manual Folding Mirrors	120

Instrument Cluster

Instrument Cluster Overview - Excluding: GT	121
Instrument Cluster Overview - GT	122
Power Gauge - GT	123
Speedometer	123
Vehicle Range Display	123
High Voltage Battery Gauge	123
What Are the Instrument Cluster Warning Lamps	124
Instrument Cluster Warning Lamps	124
What Are the Instrument Cluster Indicators	125
Instrument Cluster Indicators	126

Instrument Cluster Display

Brake Coach	127
-------------------	-----

Personalized Settings

Changing the Language	128
Changing the Measurement Unit	128
Changing the Temperature Unit	128
Changing the Tire Pressure Unit	128

Trip Computer

Accessing the Trip Computer	129
Resetting the Trip Computer	129
Trip Data	129

Remote Start

What Is Remote Start	130
Remote Start Precautions	130
Remote Start Limitations	130

Enabling Remote Start	130
Remotely Starting and Stopping the Vehicle	130
Remote Start Settings	131

Climate Control

Identifying the Climate Control Unit	132
Switching Climate Control On and Off	132
Switching Recirculated Air On and Off	132
Switching Air Conditioning On and Off	132
Switching Defrost On and Off	132
Switching Maximum Defrost On and Off	132
Switching Maximum Cooling On and Off	133
Switching the Electric Heater On and Off	133
Switching the Heated Windshield On and Off	133
Switching the Heated Rear Window On and Off	133
Setting the Blower Motor Speed	134
Switching the Heated Mirrors On and Off	134
Setting the Temperature	134
Directing the Flow of Air	134
Auto Mode	135
Climate Control Hints	136

Interior Air Quality

What Is the Cabin Air Filter	138
Replacing the Cabin Air Filter	138

Front Seats

Front Seat Precautions	139
Sitting in the Correct Position	139
Manual Seats	140
Power Seats	142
Heated Seats	145

Table of Contents

Rear Seats

Manual Seats	146
--------------------	-----

Rear Occupant Alert System

What is the Rear Occupant Alert System	148
How Does the Rear Occupant Alert System Work	148
Rear Occupant Alert System Precautions	148
Rear Occupant Alert System Limitations	148
Switching Rear Occupant Alert System On and Off	148
Rear Occupant Alert System Indicators	149
Rear Occupant Alert System Audible Warnings	149

Memory Function

What Is the Memory Function	150
Memory Function Precautions	150
Locating the Memory Function Buttons	150
Saving a Preset Position	150
Recalling a Preset Position	150

USB Ports

Locating the USB Ports	151
Playing Media Using the USB Port	151
Charging a Device	152

Power Outlet

What Is the Power Outlet	153
Power Outlet Precautions	153
Locating the Power Outlets	153

Wireless Accessory Charger

What Is the Wireless Accessory Charger	154
--	-----

Wireless Accessory Charger Precautions	154
Locating the Wireless Accessory Charger	154
Charging a Wireless Device	154

Storage

Cup Holders	155
Glove Compartment	155
Glasses Holder	155

Starting and Powering Off

Starting and Powering Off Precautions	156
Starting the Vehicle	156
Powering Off	156
Restarting the Vehicle After Powering Off	156
Accessing the Passive Key Backup Position	157
Starting and Powering Off – Troubleshooting	157

High Voltage Battery

What Is the High Voltage Battery	158
High Voltage Battery Precautions	158
Preserving Your High Voltage Battery	158
Recycling and Disposing of the High Voltage Battery	159
Energy Consumption Figures	159
Energy Consumption Figures - Excluding: GT	159
Energy Consumption Figures - GT	160
High Voltage Battery – Troubleshooting	160

Charging Your Vehicle

What is AC Charging	161
What is DC Charging	161
Charging Your Vehicle Precautions	161
Charging Equipment	161

Table of Contents

Locating the Charge Port	172
Charge Port Indicators	173
AC Charging	174
DC Charging	178
Setting the Charging Schedule and Preferences	180
Using FordPass and Charging	185
Charging Your Vehicle Hints	186
Charging Equipment Identification Symbols	186
Charging Your Vehicle – Troubleshooting	187

Electric Motor

Electric Motor Precautions	190
Selector Positions	190
Shifting Your Vehicle Into Gear	191
Temporary Neutral Mode	191
Automatic Return to Park (P)	192
Electric Motor Audible Warnings	192

All-Wheel Drive

How Does All-Wheel Drive Work	194
All-Wheel Drive Precautions	194
All-Wheel Drive Limitations	194
All-Wheel Drive – Troubleshooting	194

Brakes

Brake Precautions	195
Anti-Lock Braking System	195
Brake Over Accelerator	195
Locating the Brake Fluid Reservoir	195
Checking the Brake Fluid	195
Brake Fluid Specification	196
Brakes – Troubleshooting	196

Electric Parking Brake

What Is the Electric Parking Brake	198
Applying the Electric Parking Brake	198

Applying the Electric Parking Brake in an Emergency	198
Manually Releasing the Electric Parking Brake	198
Automatically Releasing the Electric Parking Brake	198
Electric Parking Brake Audible Warning	199
Releasing the Electric Parking Brake if the Vehicle Battery Has Run Out of Charge	199
Electric Parking Brake – Troubleshooting	199

Reverse Brake Assist

What Is Reverse Brake Assist	201
How Does Reverse Brake Assist Work	201
Reverse Brake Assist Precautions	201
Switching Reverse Brake Assist On and Off	202
Overriding Reverse Brake Assist	202
Reverse Brake Assist Indicators	202
Reverse Brake Assist – Troubleshooting	203

Cross Traffic Braking

What Is Cross Traffic Braking	205
How Does Cross Traffic Braking Work	205
Cross Traffic Braking Precautions	205
Switching Cross Traffic Braking On and Off	206
Overriding Cross Traffic Braking	206
Cross Traffic Braking Indicators	206
Cross Traffic Braking – Troubleshooting	206

Hill Start Assist

What Is Hill Start Assist	208
How Does Hill Start Assist Work	208
Hill Start Assist Precautions	208

Table of Contents

Auto Hold

How Does Auto Hold Work	209
Switching Auto Hold On and Off	209
Using Auto Hold	209
Auto Hold Indicators	209

Traction Control

What Is Traction Control	211
How Does Traction Control Work	211
Switching Traction Control On and Off	211
Traction Control Indicator	211
Traction Control – Troubleshooting	212

Stability Control

How Does Stability Control Work	213
Switching Stability Control On and Off	214
Stability Control Indicator	216

Steering

Electric Power Steering	217
Steering – Troubleshooting	218

Parking Aids

Parking Aid Precautions	219
Switching Parking Aid On and Off	219
Rear Parking Aid	220
Front Parking Aid	220
Side Parking Aid	221
Parking Aid Indicators	223
Parking Aids – Troubleshooting	223

Rear View Camera

What Is the Rear View Camera	224
Rear View Camera Precautions	224
Locating the Rear View Camera	224
Rear View Camera Guide Lines	224
Rear View Camera Object Distance Indicators	225

Rear View Camera Settings	225
---------------------------------	-----

360 Degree Camera

What Is the 360 Degree Camera	227
How Does the 360 Degree Camera Work	227
360 Degree Camera Precautions	227
360 Degree Camera Limitations	227
Locating the 360 Degree Cameras	227
360 Degree Camera Guide Lines	228
360 Degree Camera Settings	229

Active Park Assist

What Is Active Park Assist	230
How Does Active Park Assist Work	230
Active Park Assist Precautions	230
Switching Active Park Assist On and Off	230
Entering a Parallel Parking Space	230
Entering a Perpendicular Parking Space	231
Exiting a Parking Space	231
Active Park Assist – Troubleshooting	232

Adaptive Cruise Control

How Does Adaptive Cruise Control With Stop and Go Work	234
Adaptive Cruise Control Precautions	234
Adaptive Cruise Control Limitations	234
Switching Adaptive Cruise Control On and Off	236
Adaptive Cruise Control Automatic Cancellation	237
Setting the Adaptive Cruise Control Speed	237
Setting the Adaptive Cruise Control Gap	238
Canceling the Set Speed	239
Resuming the Set Speed	239

Table of Contents

Overriding the Set Speed	241
Adaptive Cruise Control Indicators	241
Switching From Adaptive Cruise Control to Cruise Control	241
Lane Centering	241
Predictive Speed Assist	244
Predictive Speed Assist – Troubleshooting	246
Adaptive Cruise Control – Troubleshooting	246

BlueCruise - Vehicles With: Hands Free Driving

What Is BlueCruise	249
How Does BlueCruise Work	249
BlueCruise Precautions	249
BlueCruise Requirements	250
BlueCruise Limitations	251
BlueCruise Settings	251
Switching BlueCruise On and Off	251
BlueCruise Alerts	252
BlueCruise Automatic Cancellation	252
BlueCruise Indicators	253
In-Lane Repositioning	254
BlueCruise – Troubleshooting	254

Drive Mode Control

What Is Drive Mode Control	256
Selecting a Drive Mode	256
Drive Modes	256

One Pedal Drive

What is One Pedal Drive	258
One Pedal Drive Precautions	258
One Pedal Drive Limitations	258
Switching One Pedal Drive On and Off	258
One Pedal Drive Indicators	258

Local Hazard Information

What Is Local Hazard Information	259
Local Hazard Information Indicators	259
Enabling Local Hazard Information	259

Speed Limiter

How Does the Speed Limiter Work	260
Speed Limiter Precautions	260
Switching the Speed Limiter On and Off	260
Setting the Speed Limit	260
Changing the Set Speed Limit	260
Canceling the Set Speed Limit	260
Resuming the Set Speed Limit	260
Intentionally Exceeding the Set Speed Limit	260
Speed Limiter Indicators	260
Speed Limiter Audible Warnings	261

Intelligent Speed Limiter

What Is the Intelligent Speed Limiter	262
How Does the Intelligent Speed Limiter Work	262
Intelligent Speed Limiter Precautions	262
Switching the Intelligent Speed Limiter On and Off	262
Setting the Speed Limit	262
Changing the Set Speed Limit	262
Adjusting the Speed Limit Tolerance	263
Canceling the Set Speed Limit	263
Resuming the Set Speed Limit	263
Intentionally Exceeding the Set Speed Limit	263
Intelligent Speed Limiter Indicators	263
Intelligent Speed Limiter Audible Warnings	263
Switching From Intelligent Speed Limiter to Speed Limiter	263

Table of Contents

Lane Keeping System

What Is the Lane Keeping System	264
How Does the Lane Keeping System Work	264
Lane Keeping System Precautions	264
Lane Keeping System Limitations	264
Switching the Lane Keeping System On and Off	265
Switching the Lane Keeping System Mode	265
Lane Keeping System Settings	265
Aid Mode	265
Alert and Aid Mode	266
Lane Keeping System Indicators	266
Blind Spot Assist	267
Lane Keeping System – Troubleshooting	269

Blind Spot Information System

What Is Blind Spot Information System	272
How Does Blind Spot Information System Work	272
Blind Spot Information System Precautions	272
Blind Spot Information System Limitations	272
Blind Spot Information System Requirements	272
Switching Blind Spot Information System On and Off	273
Locating the Blind Spot Information System Sensors	273
Blind Spot Information System Indicators	273
Blind Spot Information System – Troubleshooting	274

Cross Traffic Alert

What Is Cross Traffic Alert	275
How Does Cross Traffic Alert Work	275

Cross Traffic Alert Precautions	275
Cross Traffic Alert Limitations	275
Switching Cross Traffic Alert On and Off	275
Locating the Cross Traffic Alert Sensors	276
Cross Traffic Alert Indicators	276
Cross Traffic Alert – Troubleshooting	277

Pre-Collision Assist

What Is Pre-Collision Assist	278
How Does Pre-Collision Assist Work	278
Pre-Collision Assist Precautions	278
Pre-Collision Assist Limitations	279
Switching Pre-Collision Assist On and Off	280
Locating the Pre-Collision Assist Sensors	280
Distance Indication	281
Distance Alert	282
Automatic Emergency Braking	283
Evasive Steering Assist	283
Pre-Collision Assist – Troubleshooting	284

Driver Alert

What Is Driver Alert	286
How Does Driver Alert Work	286
Driver Alert Precautions	286
Driver Alert Limitations	286
Switching Driver Alert On and Off	287
Driver Alert Indicators	287
Driver Alert – Troubleshooting	287

Traffic Sign Recognition

What Is Traffic Sign Recognition	288
How Does Traffic Sign Recognition Work	288

Table of Contents

Traffic Sign Recognition Precautions	288
Traffic Sign Recognition Limitations	288
Traffic Sign Recognition Indicators	289
Setting the Traffic Sign Recognition Speed Warning	289
Setting the Traffic Sign Recognition Speed Tolerance	289
Traffic Sign Recognition – Troubleshooting	289

Wrong Way Alert

What Is Wrong Way Alert	290
How Does Wrong Way Alert Work	290
Wrong Way Alert Precautions	290
Wrong Way Alert Limitations	290
Switching Wrong Way Alert On and Off	290
Wrong Way Alert – Troubleshooting	291

Load Carrying

Dog Guard	292
Load Carrying Precautions	292
Roof Rack	292
Tow Bar Mounted Carrier	293

Luggage Compartment

Luggage Compartment Precautions	295
Opening the Frunk	295
Closing the Frunk	296
Using the Frunk Emergency Release	296
Installing and Removing the Luggage Compartment Cargo Net	297
Installing and Removing the Luggage Compartment Cover	297
Adjusting the Luggage Compartment Load Floor	298
Luggage Compartment Anchor Points	298

Luggage Compartment – Troubleshooting	299
---	-----

Connecting a Trailer

Tow Ball	300
----------------	-----

Towing a Trailer

Towing a Trailer Precautions	303
Towing a Trailer Limitations	303
Trailer Towing Hints	303
Towing Weights and Dimensions	304

Trailer Sway Control

How Does Trailer Sway Control Work	306
Trailer Sway Control Precautions	306

Driving Hints

Cold Weather Precautions	307
Driving on Snow and Ice	307
Breaking-In	307
Performance Vehicle Precautions	307
Driving in Special Conditions	307
Electric Vehicle	308
Driving Through Shallow Water	309
Floor Mats	310

Crash and Breakdown Information

Switching the Hazard Flashers On and Off	312
Jump Starting the Vehicle	312
Post-Crash Alert System	314
Post-Collision Braking	315
Automatic Crash Shutoff	315
Recovery Towing	315
Transporting the Vehicle	316

Towing Your Vehicle

Towing Your Vehicle Precautions	318
---------------------------------------	-----

Table of Contents

Emergency Towing	318	Using Winter Tires	343
Towing Your Vehicle – Troubleshooting	319	Using Snow Chains	344
Fuses		Tire Care	
Fuse Precautions	320	Checking the Tire Pressures	346
Under Hood Fuse Box	320	Inflating the Tires	346
Battery Fuse Box	326	Tire Pressure Specifications	346
Body Control Module Fuse Box	327	Tire Rotation	348
Identifying Fuse Types	330	Tire Sealant and Inflator Kit	
Fuses – Troubleshooting	330	What Is the Tire Sealant and Inflator Kit	349
Maintenance		Tire Sealant and Inflator Kit Precautions	349
Maintenance Precautions	331	Locating the Tire Sealant and Inflator Kit	349
Opening and Closing the Hood	331	Tire Sealant and Inflator Kit Components	349
Under Hood Overview	331	Using the Tire Sealant and Inflator Kit	350
Checking the Coolant	332	Tire Pressure Monitoring System	
12V Battery	334	What Is the Tire Pressure Monitoring System	355
12V Battery – Troubleshooting	334	Tire Pressure Monitoring System Precautions	355
Adjusting the Headlamps	335	Tire Pressure Monitoring System Limitations	355
Exterior Bulbs	335	Viewing the Tire Pressures	355
Interior Bulbs	335	Resetting Tire Pressure Monitoring System	355
Vehicle Care		Tire Pressure Monitoring System – Troubleshooting	356
General Information	336	Changing a Road Wheel	
Cleaning the Exterior	336	Wheel Nuts	358
Cleaning the Interior	337	Capacities and Specifications	
Waxing Your Vehicle	339	Vehicle Dimensions	359
Body Styling Kits			
Body Styling Kit Precautions	340		
Storing Your Vehicle			
Preparing Your Vehicle for Storage	341		
Removing Your Vehicle From Storage	342		
Wheel and Tire Information			
Locating the Tire label	343		
Using Summer Tires	343		

Table of Contents

Cooling System Capacity and Specification	360
Air Conditioning System Capacity and Specification	361
Washer Fluid Specification	361
Brake Fluid Specification	362

Vehicle Identification

Vehicle Identification Number	363
Vehicle Identification Plate	363
Installing the Vehicle Identification Card	364

Connected Vehicle

What Is a Connected Vehicle	365
Connected Vehicle Requirements	365
Connected Vehicle Limitations	365
Connecting the Vehicle to a Mobile Network	365
Connecting the Vehicle to a Wi-Fi Network	365
Connected Vehicle – Troubleshooting	366

Vehicle Wi-Fi Hotspot

Creating a Vehicle Wi-Fi Hotspot	368
Changing the Vehicle Wi-Fi Hotspot Name or Password	369
Vehicle Wi-Fi Hotspot – Troubleshooting	369

Audio System

Audio System Precautions	370
Switching the Audio Unit On and Off	370
Selecting the Audio Source	370
Playing or Pausing the Audio Source	370
Adjusting the Volume	370
Switching Shuffle Mode On and Off	370

Switching Repeat Mode On and Off	370
Setting a Memory Preset	370
Muting the Audio	371
Adjusting the Sound Settings	371
Setting the Clock and Date	371
FM Radio	371
Digital Audio Broadcasting Radio	372
Traffic Announcements	373

Center Display Overview

Center Display Precautions	375
Center Display Limitations	375
Status Bar	375
Center Display Settings	376
Rebooting the Center Display	376

Voice Interaction

Ford Assistant	377
----------------------	-----

Phone

Phone Precautions	379
Connecting Your Phone	379
Phone Menu	379
Making and Receiving a Phone Call	380
Sending and Receiving a Text Message	381
Switching Text Message Notification On and Off	382

Bluetooth®

Connecting a Bluetooth® Device	383
Playing Media Using Bluetooth®	383

Apps

App Precautions	384
App Requirements	384
Accessing Apps	384
Enabling Apps on an iOS Device	384

Table of Contents

Enabling Apps on an Android Device	385	Radio Frequency Certification Labels	395
Switching Apple CarPlay On and Off	385	Replacement Parts Recommendation	424
Switching Android Auto On and Off	385	Mobile Communications Equipment	424
Personal Profiles		eCall User Information	425
How Do Personal Profiles Work	386	End User License Agreement	429
Enabling or Disabling Personal Profiles	386	Appendices	
Creating a Personal Profile	386	Electromagnetic Compatibility	455
Linking or Unlinking a Personal Profile	386		
Selecting a Personal Profile	387		
Deleting a Personal Profile	387		
Navigation			
Connected Navigation	388		
Accessing Navigation	388		
Navigation Map Updates	388		
Adjusting the Map	388		
Live Traffic	388		
Setting a Destination	388		
Waypoints	389		
Route Guidance	389		
Vehicle Software Updates			
Vehicle Software Updates	391		
Software Update Settings	391		
Software Update Indicators	392		
Vehicle System Reset			
Performing a System Reset	393		
Customer Information			
Rollover Warning	394		
Third Party Software Copyright Acknowledgment	394		
Declaration of Conformity	394		
REACH	394		

Introduction

ABOUT THIS PUBLICATION



WARNING: Driving while distracted can result in loss of vehicle control, crash and injury. We strongly recommend that you use extreme caution when using any device that may take your focus off the road. Your primary responsibility is the safe operation of your vehicle. We recommend against the use of any hand-held device while driving and encourage the use of voice-operated systems when possible. Make sure you are aware of all applicable local laws that may affect the use of electronic devices while driving.



WARNING: You risk death, fire, or serious injury to yourself and others if you do not follow the instruction highlighted by the warning symbol.

Thank you for choosing Ford. We recommend that you take some time to get to know your vehicle in order to benefit from greater safety and pleasure from driving it. Use this publication to familiarize yourself with the basics and then read the digital version, that is available in your vehicle. You can also view the comprehensive manual through the FordPass app and through the local Ford website.

Note: To download the FordPass app, visit your device's app store.

Note: To find the local Ford website, visit <https://corporate.ford.com/operations/locations/global-links.html>.

Note: Use and operate your vehicle in line with all applicable laws and regulations.

Note: Pass on all printed owner's information when selling this vehicle.

Our digital resources include a comprehensive digital Owner's Manual dynamically created according to the features on your vehicle by using the vehicle identification number. See **Locating the Vehicle Identification Number** (page 363). The digital Owner's Manual includes visual and full text search functions so that you can quickly locate the information you are looking for. It also includes links to a number of how-to videos created to help you understand some of the advanced technologies on your vehicle.

Features and Options

This publication describes product features and options available throughout the range of available models, sometimes even before they are generally available. It could describe options that are not available on the vehicle you have purchased.

Illustrations

Some of the illustrations in this publication could show features as used in different models, so they could appear different to you on your vehicle.

Location of Components

This manual may qualify the location of a component as left-hand side or right-hand side. The side is determined when facing forward in the seat.

Introduction

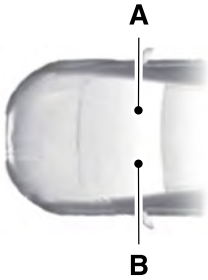

- A Right-hand side.
- B Left-hand side.





























USING THIS PUBLICATION

To quickly locate information about your vehicle, use the word search within the Owner's Manual application.

Symbols Glossary

SYMBOLS USED ON YOUR VEHICLE

These are some of the symbols you may see on your vehicle.

	Airbag		Child seat lower anchor
	Air conditioning system		Child seat tether anchor
	Air conditioning system lubricant type		Cruise control
	Anti-lock braking system		Do not open when hot
	Avoid smoking, flames or sparks		Electric Parking brake
	Battery		Explosive gas
	Battery acid		Fan warning
	Blower motor		Fasten seatbelt
	Brake fluid - non petroleum based		Flammable
	Brake system		Front fog lamps
	Brake system		Fuse compartment
	Cabin air filter		Hazard flashers
	Child safety door lock or unlock		Headlamp high beams
			Headlamps on
			Heated rear window

Symbols Glossary



Hill descent control



Horn control



Interior luggage compartment release



Jack



Keep out of reach of children



Lighting control



Low tire pressure warning



Maintain correct fluid level



Malfunction Indicator Lamp (MIL)



Note operating instructions



Panic alarm



Parking aid



Parking lamps



Passenger airbag activated



Passenger airbag deactivated



Power steering fluid



Power windows front/rear



Power window lockout



Requires registered technician



Safety alert



See Owner's Manual



See Service Manual



Side airbag



Shield the eyes



Stability control



Stability control off



Trail control



Turn Signal



Windshield defrosting system



Windshield wiping system

Symbols Glossary



Windshield wash and wipe

Data Privacy



WARNING: Do not connect wireless plug-in devices to the data link connector. Unauthorized third parties could gain access to vehicle data and impair the performance of safety related systems. Only allow repair facilities that follow our service and repair instructions to connect their equipment to the data link connector.

We respect your privacy and are committed to protecting it. The information contained in this publication was correct at the time of release, but as technology rapidly changes, we recommend that you visit the local Ford website for the latest information.

Your vehicle has electronic control units that have data recording functionality and the ability to permanently or temporarily store data. This data could include information on the condition and status of your vehicle, vehicle maintenance requirements, events and malfunctions. The types of data that can be recorded are described in this section. Some of the data recorded is stored in event logs or error logs.

Note: *Error logs are reset following a service or repair.*

Note: *We may provide information in response to requests from law enforcement, other government authorities and third parties acting with lawful authority or through a legal process. Such information could be used by them in legal proceedings.*

Data recorded includes, for example:

- Operating states of system components, for example battery charge level and tire pressure.
- Vehicle and component status, for example wheel speed, deceleration, lateral acceleration and seatbelt status.

- Events or errors in essential systems, for example headlamps and brakes.
- System responses to driving situations, for example airbag deployment and stability control.
- Environmental conditions, for example temperature.

Some of this data, when used in combination with other information, for example an accident report, damage to a vehicle or eyewitness statements, could be associated with a specific person.

Services That We Provide

If you use our services, we collect and use data, for example account information, vehicle location and driving characteristics, that could identify you. We transmit this data through a dedicated, protected connection. We only collect and use data to enable your use of our services to which you have subscribed, with your consent or where permitted by law. For additional information, see the terms and conditions of the services to which you have subscribed.

For additional information about our privacy policy, refer to the local Ford website.

Services That Third Parties Provide

We recommend that you review the terms and conditions and data privacy information for any services equipped with your vehicle or to which you subscribe. We take no responsibility for services that third parties provide.

Data Privacy

SERVICE DATA

Our dealers collect service data through the data link connector in your vehicle. They use service data, for example error logs, to help them if you take your vehicle for repair. They share this data with our technical team, if required, to help with diagnosis. In addition to using the information for diagnosis and repair, we use and share service data with our service providers, for example parts suppliers, where required and where permitted by law, for continuous improvement or with other information that we have about you, for example your contact information, to offer you products and services that may be of interest to you according to your preferences and where allowed by law. Our service providers are equally required by law to protect your data and retain it in accordance with data retention policies.

Note: *Third party repair facilities can also collect service data through the data link connector.*

EVENT DATA

This vehicle is equipped with an event data recorder. The main purpose of an event data recorder is to record, in certain crash or near crash-like situations, such as an airbag deployment or hitting a road obstacle; this data will assist in understanding how a vehicle's systems performed. The event data recorder is designed to record data related to vehicle dynamics and safety systems for a short period of time, typically 30 seconds or less.

The event data recorder in this vehicle is designed to record such data as:

- How various systems in your vehicle were operating.
- Whether or not the driver and passenger seatbelts were buckled/fastened.
- How far (if at all) the driver was depressing the accelerator and/or the brake pedal.
- How fast the vehicle was traveling.
- Where the driver was positioning the steering wheel.

This data can help provide a better understanding of the circumstances in which crashes and injuries occur.

Note: *Event data recorder data is recorded by your vehicle only if a non-trivial crash situation occurs; no data is recorded by the event data recorder under normal driving conditions and no personal data or information (for example name, gender, age, and crash location) is recorded. However, parties, such as law enforcement, could combine the event data recorder data with the type of personally identifying data routinely acquired during a crash investigation.*

To read data recorded by an event data recorder, special equipment is required, and access to the vehicle or the event data recorder is needed. In addition to the vehicle manufacturer, other parties, such as law enforcement, that have such special equipment, can read the information if they have access to the vehicle or the event data recorder.

Data Privacy

BlueCruise Data (If Equipped)

If BlueCruise is active in certain crash or near crash-like situations, such as an airbag deployment or hitting a road obstacle, the system may record driver attentiveness, based on the direction of eyes and duration, and photographs of the driver seat area.

Note: *No data is recorded under normal driving conditions.*

SETTINGS DATA

Your vehicle has electronic control units that have the ability to store data based on your personalized settings. The data is stored locally in the vehicle or on devices that you connect to it, for example, a USB drive or digital music player. You can delete some of this data and also choose whether to share it through the services to which you subscribe.

Comfort and Convenience Data

Data recorded includes, for example:

- Seat and steering wheel position.
- Climate control settings.
- Radio presets.

Entertainment Data

Data recorded includes, for example:

- Music, videos or album art.
- Contacts and corresponding address book entries.
- Navigation destinations.

CONNECTED VEHICLE DATA



The modem has a SIM. The modem was enabled when your vehicle was built and periodically sends messages to stay connected to the cell phone network. Subject to your consent, the vehicle may send vehicle, driving and location data. These messages could include information that identifies your vehicle, the SIM and the electronic serial number of the modem. Cell phone network service providers could have access to additional information, for example cell phone network tower identification. For additional information about our privacy policy, visit www.FordConnected.com or refer to your local Ford website.

Note: *The modem continues to send information unless you disable the modem or stop the modem from sharing data by changing the modem settings. See **Connected Vehicle** (page 365).*

Note: *The service can be unavailable or interrupted for a number of reasons, for example environmental or topographical conditions and data plan coverage.*

Note: *To find out if your vehicle has a modem, visit www.FordConnected.com.*

MOBILE DEVICE DATA

If you connect a mobile device to your vehicle, you can display data from your device on the touchscreen for example, music and album art. You can share your vehicle data with mobile apps on your device through the system. See **App Requirements** (page 384).

Data Privacy

The mobile apps function operates by your connected device sending data to us in the United States. The data is encrypted and includes, for example, the vehicle identification number of your vehicle, the SYNC module serial number, odometer, enabled apps, usage statistics and debugging information. We retain it only as long as necessary to provide the service, to troubleshoot, for continuous improvement and to offer you products and services that may be of interest to you according to your preferences and where allowed by law.

If you connect a cell phone to the system, the system creates a profile that links to that cell phone. The cell phone profile enables more mobile features and efficient operation. The profile contains, for example data from your phonebook, read and unread text messages and call history, including history of calls when your cell phone was not connected to the system.

If you connect a media device, the system creates and retains a media device index of supported media content. The system also records a short diagnostic log of approximately 10 minutes of all recent system activity.

The cell phone profile, media device index and diagnostic log remain in your vehicle unless you delete them and are generally accessible only in your vehicle when you connect your cell phone or media device. If you no longer plan to use the system or your vehicle, we recommend you use the master reset function to erase the stored information. See **Performing a System Reset** (page 393).

System data cannot be accessed without special equipment and access to your vehicle's module.

For additional information about our privacy policy, refer to the local Ford website.

Note: To find out if your vehicle has connectivity technology, visit www.FordConnected.com.

EMERGENCY CALL SYSTEM DATA

When the emergency call system is active, it may disclose to emergency services that your vehicle has been in a crash involving the deployment of an airbag or activation of the battery shut-off. Certain versions or updates to the emergency call system may also be capable of electronically or verbally disclosing to emergency services operators your vehicle location or other details about your vehicle or crash to assist emergency services operators to provide the most appropriate emergency services. If you do not want to disclose this information, do not activate the emergency call system.

Examples of data that the system could transmit are:

- Vehicle identification number.
- Vehicle fuel type.
- Current time.
- Vehicle location and direction.
- Whether the call was automatically or manually initiated.
- Vehicle category.
- Number of occupants in the vehicle.

Note: You cannot deactivate emergency call systems that are required by law.

Environment

PROTECTING THE ENVIRONMENT

You can take significant steps toward protecting the environment with correct vehicle usage and the authorized disposal of waste, cleaning and lubrication materials.

For additional information about our sustainability progress and initiatives, visit www.sustainability.ford.com.

France Only



Points de collecte sur www.quefairedemesdechets.fr et www.ford.fr

Visual Search

STEERING WHEEL



- A See **Switching Adaptive Cruise Control On and Off** (page 236).
- B See **Setting the Adaptive Cruise Control Speed** (page 237).
- C See **Setting the Adaptive Cruise Control Gap** (page 238).
- D See **Using Ford Assistant** (page 377).
- E See **Adjusting the Volume** (page 370).
- F See **Selecting an FM Radio Station** (page 372).
- G See **Making and Receiving a Phone Call** (page 380).
- H See **Switching Lane Centering On and Off** (page 243).

Visual Search

INSTRUMENT PANEL - LHD, EXCLUDING: GT

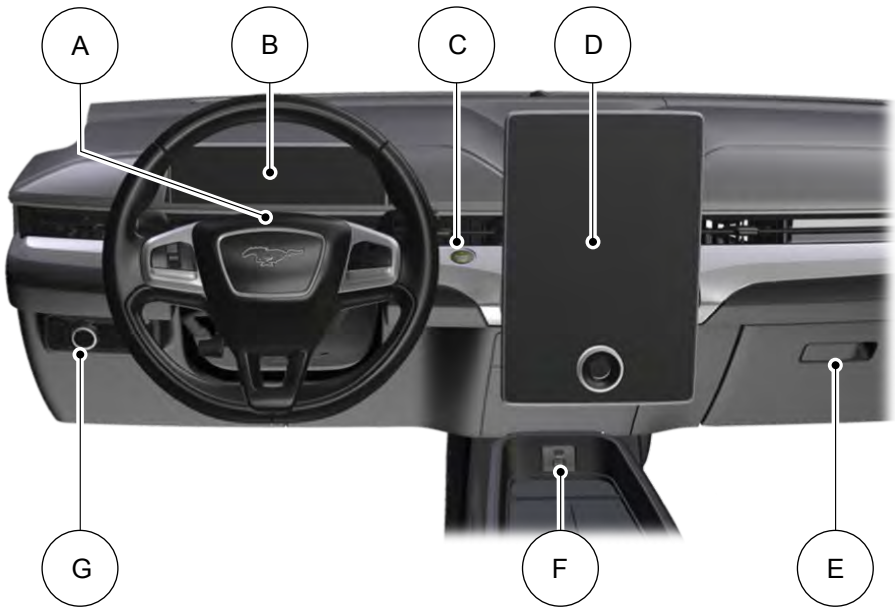

- A See **How Does BlueCruise Work** (page 249).
- B See **Instrument Cluster Overview** (page 121).
- C See **Starting the Vehicle** (page 156).
- D See **Status Bar** (page 375).
- E See **Opening the Glove Compartment** (page 155).
- F See **Locating the USB Ports** (page 151).
- G See **Exterior Lighting Control** (page 104).

Visual Search

INSTRUMENT PANEL - RHD, EXCLUDING: GT

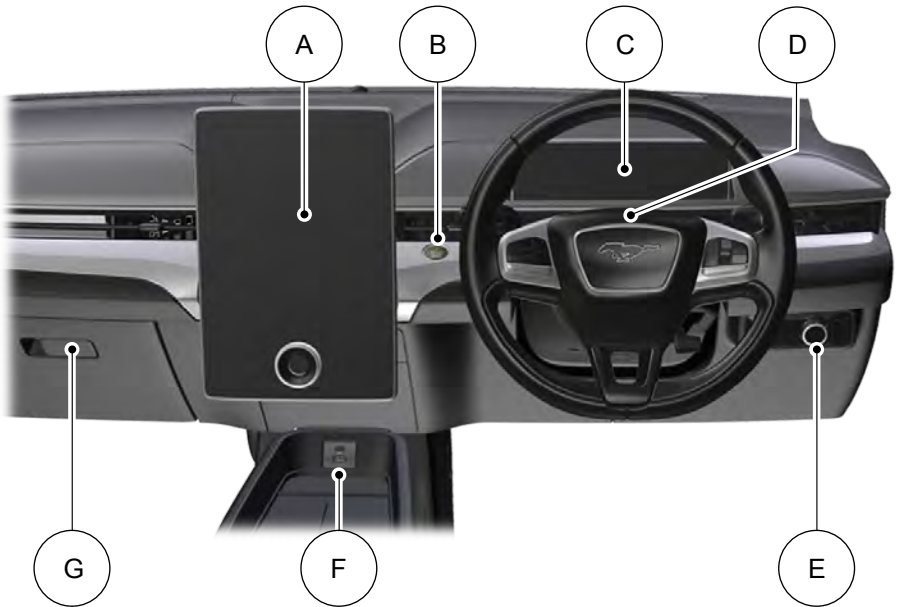

- A See **Status Bar** (page 375).
- B See **Starting the Vehicle** (page 156).
- C See **Instrument Cluster Overview** (page 121).
- D See **How Does BlueCruise Work** (page 249).
- E See **Exterior Lighting Control** (page 104).
- F See **Locating the USB Ports** (page 151).
- G See **Opening the Glove Compartment** (page 155).

Visual Search

INSTRUMENT PANEL - GT, LHD

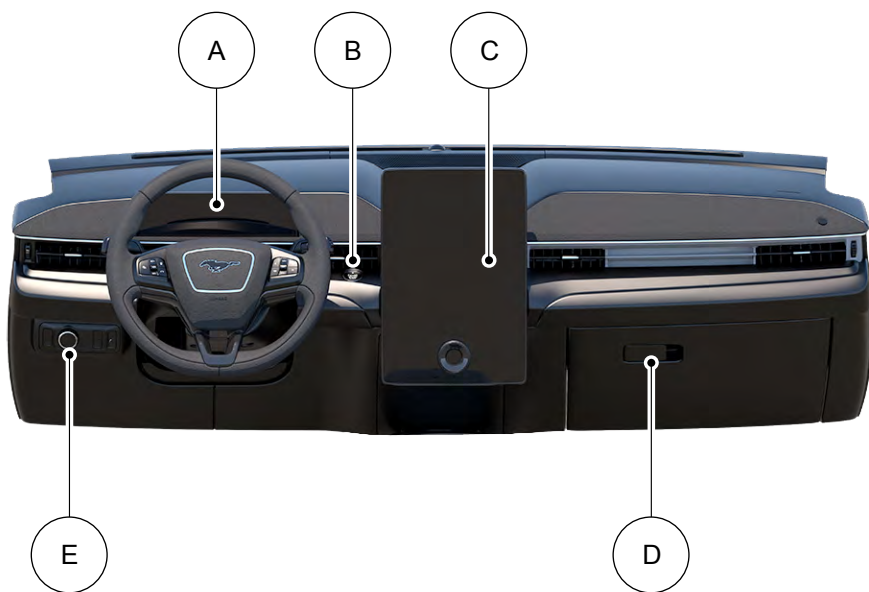

- A See **Instrument Cluster Overview** (page 121).
- B See **Starting the Vehicle** (page 156).
- C See **Status Bar** (page 375).
- D See **Opening the Glove Compartment** (page 155).
- E See **Exterior Lighting Control** (page 104).

Visual Search

INSTRUMENT PANEL - GT, RHD

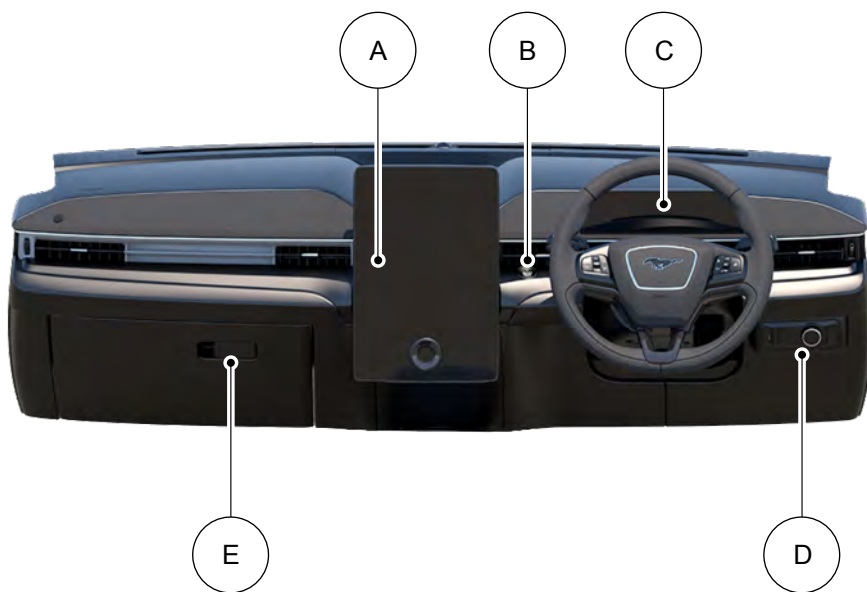

- A See **Status Bar** (page 375).
- B See **Starting the Vehicle** (page 156).
- C See **Instrument Cluster Overview** (page 121).
- D See **Exterior Lighting Control** (page 104).
- E See **Opening the Glove Compartment** (page 155).

Visual Search

CENTER CONSOLE - GT

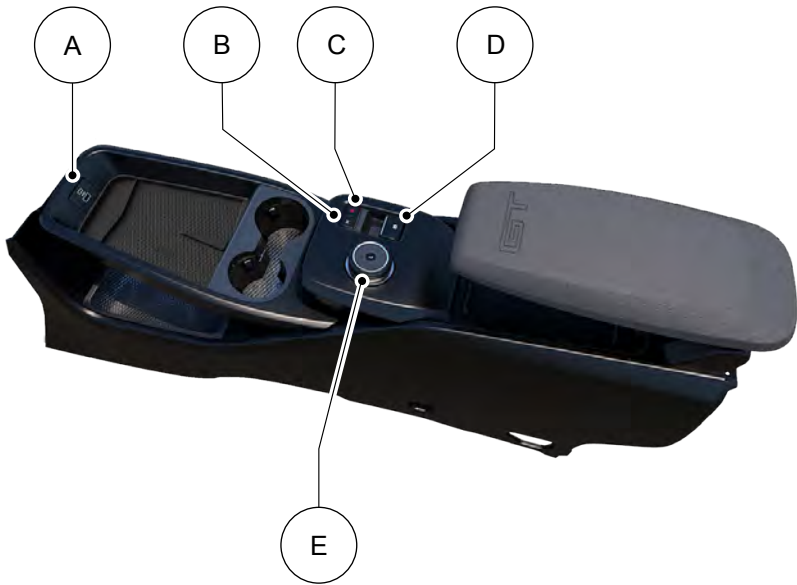

- A See **Locating the USB Ports** (page 151).
- B See **Switching Active Park Assist On and Off** (page 230).
- C See **Switching the Hazard Flashers On and Off** (page 312).
- D See **Applying the Electric Parking Brake** (page 198).
- E See **Shifting Your Vehicle Into Gear** (page 191).

Visual Search

VEHICLE INTERIOR - LHD, EXCLUDING: GT

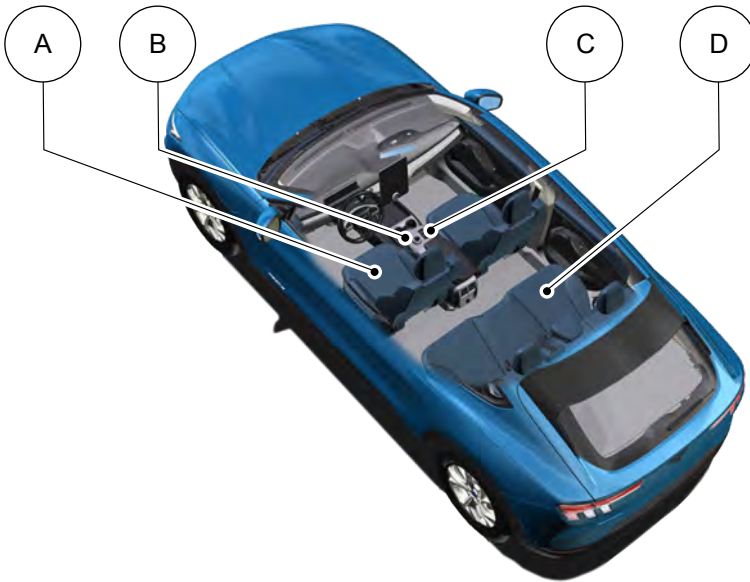

- A See **Sitting in the Correct Position** (page 139).
- B See **Shifting Your Vehicle Into Gear** (page 191).
- C See **Applying the Electric Parking Brake** (page 198).
- D See **Folding the Seat Backrest** (page 147).

Visual Search

VEHICLE INTERIOR - RHD, EXCLUDING: GT

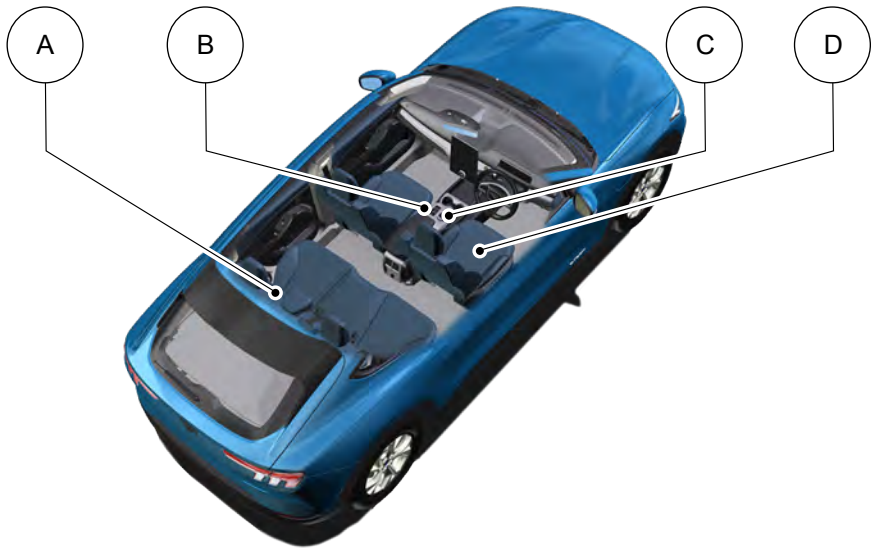

- A See **Folding the Seat Backrest** (page 147).
- B See **Applying the Electric Parking Brake** (page 198).
- C See **Shifting Your Vehicle Into Gear** (page 191).
- D See **Sitting in the Correct Position** (page 139).

Visual Search

VEHICLE INTERIOR - GT, LHD

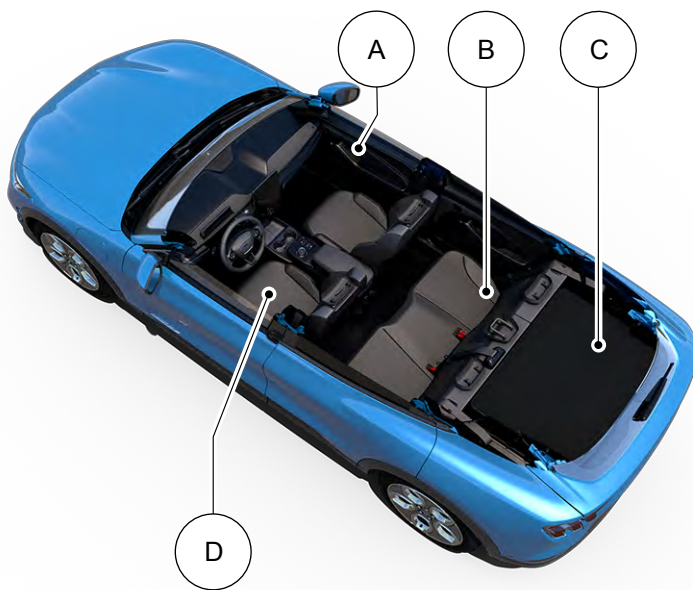

- A See **Opening and Closing the Windows** (page 115).
- B See **Folding the Seat Backrest** (page 147).
- C See **Installing and Removing the Luggage Compartment Cover** (page 297).
- D See **Sitting in the Correct Position** (page 139).

Visual Search

VEHICLE INTERIOR - GT, RHD

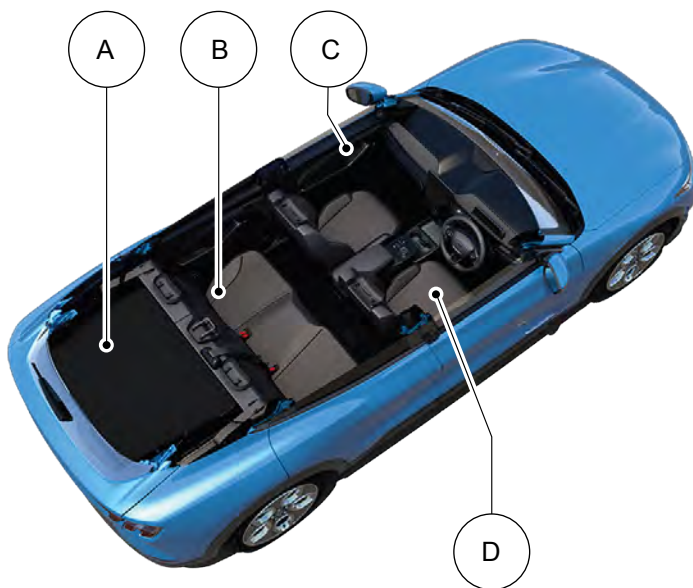

- A See **Installing and Removing the Luggage Compartment Cover** (page 297).
- B See **Folding the Seat Backrest** (page 147).
- C See **Opening and Closing the Windows** (page 115).
- D See **Sitting in the Correct Position** (page 139).

Visual Search

FRONT EXTERIOR - EXCLUDING: GT

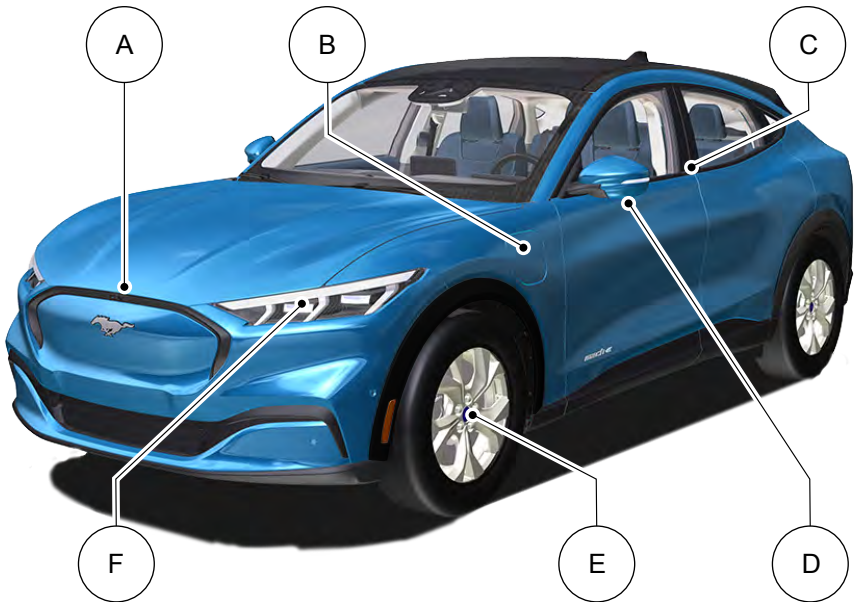

- A See **Opening the Frunk from Outside Your Vehicle** (page 295).
- B See **Locating the Charge Port** (page 172).
- C See **Locating the Keyless Entry Keypad** (page 80).
- D See **Folding the Exterior Mirrors** (page 120).
- E See **What Is the Tire Pressure Monitoring System** (page 355).
- F See **Exterior Lighting Control** (page 104).

Visual Search

FRONT EXTERIOR - GT

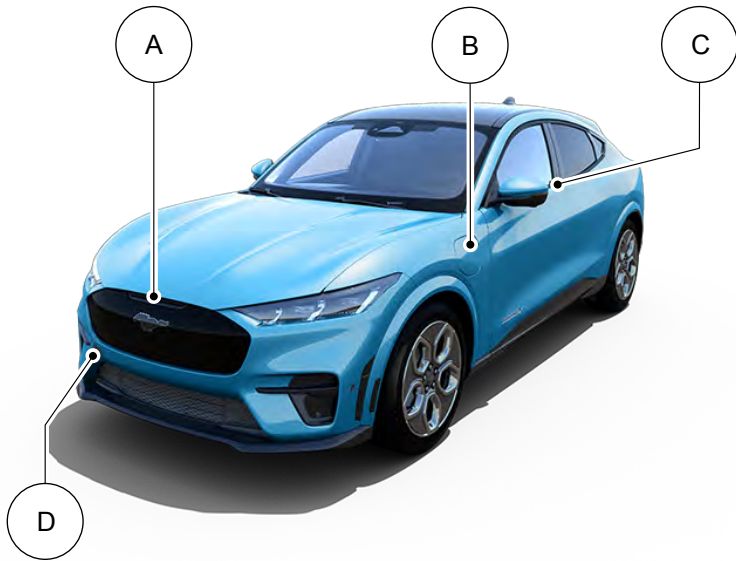

- A See **Opening the Frunk from Outside Your Vehicle** (page 295).
- B See **Locating the Charge Port** (page 172).
- C See **Locating the Keyless Entry Keypad** (page 80).
- D See **Preparing the Vehicle** (page 312).

Visual Search

REAR EXTERIOR - EXCLUDING: GT

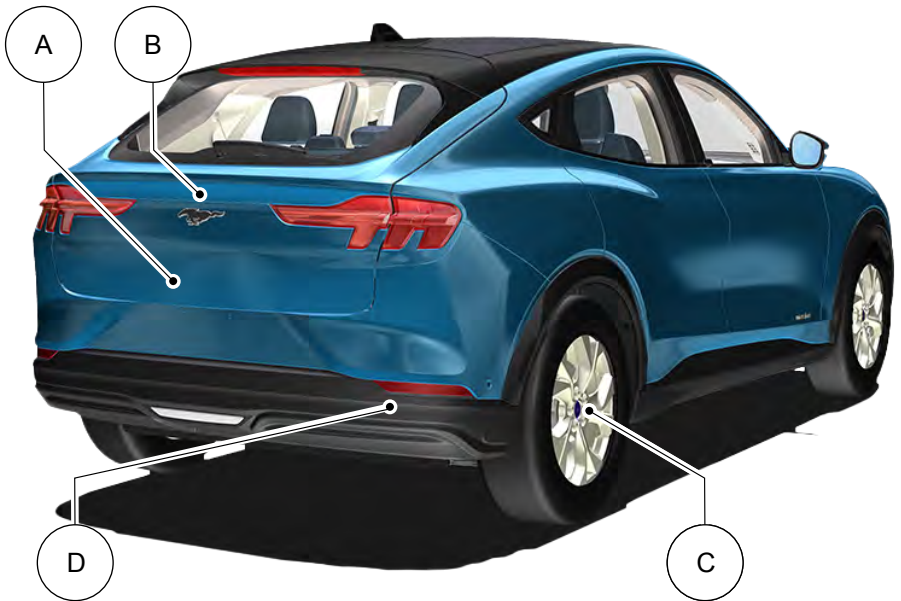

- A See **Opening the Liftgate From Outside Your Vehicle** (page 85).
- B See **Locating the Rear View Camera** (page 224).
- C See **What Is the Tire Pressure Monitoring System** (page 355).
- D See **Locating the Rear Parking Aid Sensors** (page 220).

Visual Search

REAR EXTERIOR - GT

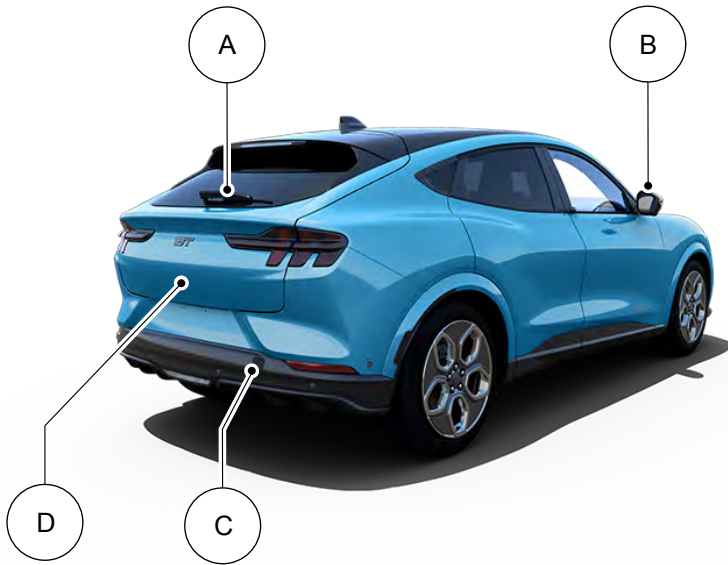

- A See **Switching the Rear Window Wiper On and Off** (page 100).
- B See **Folding the Exterior Mirrors** (page 120). See **Folding the Exterior Mirrors** (page 119).
- C See **Locating the Rear Parking Aid Sensors** (page 220).
- D See **Opening the Liftgate From Outside Your Vehicle** (page 85).

Child Safety

CHILD SAFETY PRECAUTIONS



Only child restraints certified to ECE-R129 or ECE-R44.03 (or later) have been tested and approved for use in your vehicle.

Note: *Mandatory use of child restraints varies from country to country.*

⚠ WARNING: Extreme Hazard! Never use a rearward facing child restraint on a seat protected by an active airbag in front of it. Death or serious injury to the child can occur.

⚠ WARNING: You must switch the passenger airbag off when using a rearward facing child restraint on the front seat.

⚠ WARNING: You must switch the passenger airbag on following the removal of the child restraint.

⚠ WARNING: Do not modify child restraints in any way.

⚠ WARNING: Do not hold a child on your lap when your vehicle is moving.

⚠ WARNING: Do not leave children or pets unattended in your vehicle. Failure to follow this instruction could result in personal injury or death.

⚠ WARNING: If your vehicle has been involved in a crash, have the child restraints checked.

⚠ WARNING: Do not put the shoulder section of the seatbelt or allow the child to put the shoulder section of the seatbelt under their arm or behind their back. Failure to follow this instruction could reduce the effectiveness of the seatbelt and increase the risk of injury or death in a crash.

⚠ WARNING: Do not use pillows, books or towels to boost your child's height. Failure to follow this instruction could result in personal injury or death.

⚠ WARNING: You must reinstall the head restraint following the removal of the child restraint.

⚠ WARNING: Always make sure your child is secured properly in a device that is appropriate for their height, age and weight. Child safety restraints must be bought separately from your vehicle. Failure to follow these instructions and guidelines may result in an increased risk of serious injury or death to your child.

Child Safety

WARNING: If you use a child restraint and a seatbelt, make sure that the seatbelt is not slack or twisted.

WARNING: Do not install a booster seat or a booster cushion with only the lap strap of the seatbelt.

WARNING: Do not install a booster seat or a booster cushion with a seatbelt that is slack or twisted.

WARNING: Make sure that your children sit in an upright position.

CHILD RESTRAINT ANCHOR POINTS

WHAT ARE THE CHILD RESTRAINT ANCHOR POINTS

[*LATCH \(Lower Anchors and Tethers for Children\)*](#)

Anchor points are designed to allow you to quickly and safely install a child restraint.

LOCATING THE CHILD RESTRAINT LOWER ANCHOR POINTS



Lower anchor points are on the rear outermost seats.

LOCATING THE CHILD RESTRAINT TOP TETHER ANCHOR POINTS



Top tether anchor points are on the back of the rear seat.

Child Safety

CHILD RESTRAINTS

CHILD RESTRAINT POSITION INFORMATION

Seating Positions	Mass Group Categories				
	0	0+	1	2	3
	0–10 kg (0–22 lb)	0–13 kg (0–29 lb)	9–18 kg (20–40lb)	15–25 kg (33–55lb)	22–36 kg (49–79 lb)
Front passenger seat with airbag ON .	X	X	UF ¹	UF ¹	UF ¹
Front passenger seat with airbag OFF .	U ¹	U ¹	U ¹	U ¹	U ¹
Rear seats. ²	U	U	U	U	U

¹ We recommend that you secure children in a government approved child restraint, on the rear seat.

² Do not use a child restraint with a support leg on the rear center seat unless stated as suitable in the child restraint manufacturer's product information.

X Not suitable for children in this mass group.

U Suitable for universal category child restraints approved for use in this mass group.

UF Suitable for universal category forward facing child restraints approved for use in this mass group.

ISOFIX Child Restraints

Seating Positions		Mass Group Categories				
		0	0	0+	1	1
		Lateral Facing	Rearward Facing	Rearward Facing	Forward Facing	Rearward Facing
		0–10 kg (0–22lb)	0–10 kg (0–22lb)	0–13 kg (0–29lb)	9–18 kg (20–40lb)	9–18 kg (20–40lb)
Front passenger seat.	Size class.	No ISOFIX				
	Size type.					
Rear outermost seat ISOFIX.	Size class.	X	E ¹	C, D, E ¹	A, B, B ¹	C, D ¹

Child Safety

Seating Positions		Mass Group Categories				
		0	0	0+	1	1
		Lateral Facing	Rearward Facing	Rearward Facing	Forward Facing	Rearward Facing
		0–10 kg (0–22lb)	0–10 kg (0–22lb)	0–13 kg (0–29lb)	9–18 kg (20–40lb)	9–18 kg (20–40lb)
	Fixture.	X	R1 ¹	R1, R2X, R2, R3 ¹	F2, F2X, F3 ¹	R2X, R2, R3 ¹
	Size type.	X	IL	IL	IL, IUF	IL
Rear center seat.	Size class.	No ISOFIX				
	Size type.					

¹The size class and fixture are defined for both universal and semi-universal child restraint systems. You can see the identification letters on ISOFIX child restraints.

IL Suitable for use with particular ISOFIX child restraint systems in the semi-universal category. Refer to the child restraint system manufacturer vehicle recommendation list for additional information.

IUF Suitable for use with forward facing ISOFIX child restraint systems in the universal category.

i-Size Child Restraints

	Front Passenger Seat	Rear Outermost Seats	Rear Center Seat
Rearward facing child restraint systems on front passenger seat with airbag ON .	X	-	-
i-Size child restraint systems.	X	i-U	X
Suitable booster fixture.	B2, B3 ¹	B2, B3 ¹	B2, B3 ¹

¹The fixture is defined for booster child restraint systems. You can see the identification letters on i-Size boosters.

i-U Suitable for use with forward and rearward facing i-Size child restraint systems.

X Not suitable for use with i-Size child restraint systems.

Child Safety

CHILD RESTRAINTS RECOMMENDATION

Mass Group Categories	Manufacturer	Model	Attachment
0+ 0–13 kg (0–29 lb)	Britax Römer.	Baby Safe Plus with ISOFIX base. ¹	ISOFIX base or seatbelt only.
1 9–18 kg (20–40 lb)	Britax Römer.	Duo Plus. ¹	ISOFIX and top tether anchors or seatbelt only.
2 15–25 kg (33–55 lb)	Britax Römer.	KidFix. ^{1,2}	ISOFIX and seatbelt or seatbelt only.
3 22–36 kg (49–79 lb)	Britax Römer.	KidFix. ^{1,2}	ISOFIX and seatbelt or seatbelt only.

¹We recommend that you secure children using an ISOFIX child restraint on the rear outermost seats.

²We recommend that you use a booster seat that combines a cushion with a backrest instead of a booster cushion only.

See an authorized dealer for the latest details relating to our recommended child restraints.

Child Safety

INSTALLING CHILD RESTRAINTS



WARNING: Read and follow the manufacturer's instructions when you are installing a child restraint.

Note: Always follow the manufacturer's instructions for installing a child restraint with a top tether.



WARNING: Do not attach the top tether strap to anything other than the correct top tether strap anchor point.



WARNING: Make sure that the top tether strap is not slack or twisted and is properly located on the anchor point.



WARNING: If you use a child restraint that has a support leg, make sure the support leg rests securely on the floor.



WARNING: Make sure the child restraint rests tightly against the vehicle seat. You may need to adjust the seats to properly secure the child restraint. Make sure that the seat backrest is in an upright position. It may also be necessary to lift or remove the head restraint.

When using a child restraint on a front seat, follow these seat positioning guidelines:

- The child restraint must not be in contact with the instrument panel.
- Position the passenger seat as far rearward as possible and route the seatbelt forward and downward from the B-pillar ring to the child restraint.
- If it proves difficult to tighten the lap section of the seatbelt without slack remaining, adjust the seat backrest to the fully upright position and raise the height of the seat.

Note: When using a child restraint on a rear seat, adjust the front seat to a position to prevent contact with the child's feet or legs.

BOOSTER SEATS

Booster Seat



Secure children that weigh greater than 15 kg (33 lb) but are less than 150 cm (60 in) tall in a booster seat or on a booster cushion.

We recommend that you use a booster seat that combines a cushion with a backrest instead of a booster cushion only. The raised seating position will allow you to position the shoulder strap of the adult seatbelt over the center of your child's shoulder and the lap strap tightly across their hips.

Booster Cushion



WARNING: When using a booster cushion, make sure you adjust the vehicle head restraint on that seating position.

Child Safety



Secure children that weigh greater than 22 kg (49 lb) but are less than 150 cm (60 in) tall on a booster cushion.

CHILD SAFETY LOCKS



WARNING: You cannot open the rear doors from inside if you have put the child safety locks on.



The control is on the driver door. It enables both the child safety locks and the rear window locks.

Press the control to switch the child safety locks and the rear window lock on. Press the control again to switch them off. A light on the control illuminates when you switch them on.

The child lock and rear window lock settings remain active when you switch your vehicle off.

Note: To make sure the child safety lock is on, pull the inside door handle twice to verify the door does not open.

Note: To open the rear doors from inside the vehicle when the child lock is engaged, roll down the rear window and use the outside door handle. Or have someone outside the vehicle open the door.

Seatbelts

SEATBELT PRECAUTIONS



WARNING: Make sure that the seatbelts are securely stowed away when not in use and not outside your vehicle when closing the doors.



WARNING: Accessory seat covers not released by Ford Motor Company could prevent the seatbelt from retracting correctly. This could cause the seatbelt to become slack which could increase the risk of injuries in a crash.

FASTENING AND UNFASTENING THE SEATBELTS

All seatbelts in your vehicle are a three-point combination lap and shoulder seatbelt.

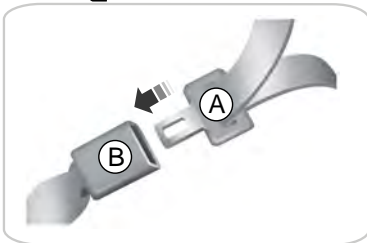

- A Seatbelt tongue.
- B Seatbelt buckle.

1. Pull the seatbelt out steadily.

Note: *It may lock if you pull it sharply or if the vehicle is on a slope.*

2. Insert the tongue into the buckle.
3. Pull the seatbelt tight to remove any slack.

Unfastening the Seatbelts

1. Press the red button on the buckle to release the seatbelt.
2. Hold the seatbelt tongue and let it retract completely and smoothly to its stowed position.

ADJUSTING THE SEATBELTS DURING PREGNANCY



WARNING: Position the seatbelt correctly for your safety and that of your unborn child. Do not use only the lap strap or the shoulder strap.

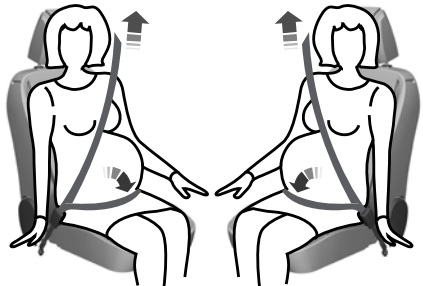

Seatbelts

Pregnant women should always wear their seatbelt. The lap belt portion of a combination lap and shoulder belt should be positioned low across the hips below the belly and worn as tight as comfort will allow. The shoulder belt portion of a combination lap and shoulder belt should be positioned to cross the middle of the shoulder and the center of the chest.

ADJUSTING THE SEATBELT HEIGHT



WARNING: Position the seatbelt height adjuster so that the seatbelt rests across the middle of your shoulder. Failure to adjust the seatbelt correctly could reduce its effectiveness and increase the risk of injury in a crash.

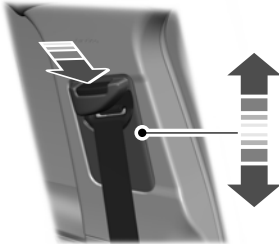

1. Press the button and slide the height adjuster up or down.
2. Release the button and pull down on the height adjuster to make sure it is locked in place.

SEATBELT REMINDER

SEATBELT REMINDER INDICATORS

An indicator illuminates if the power is on and any of the following occur:

- A front seat is occupied and the seatbelt has not been fastened.
- A rear seatbelt has been recently unfastened.



The indicator illuminates until you fasten your seatbelt.

SEATBELT REMINDER AUDIBLE WARNINGS

A warning tone sounds if the indicator illuminates and your vehicle exceeds a relatively low speed.

The warning tone sounds for up to five minutes or until you fasten your seatbelt.

SWITCHING THE SEATBELT REMINDER ON AND OFF

We recommend that you contact an authorized dealer.

CHECKING SEATBELT STATUS

To view the seatbelt status, use the touchscreen.

Seatbelts

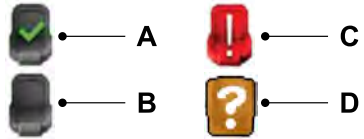

- A Seatbelt fastened.
- B Seatbelt not fastened.
- C Seatbelt recently unfastened.
- D Fault.

SEATBELTS – TROUBLESHOOTING

SEATBELTS – INFORMATION MESSAGES

Message	Description
Rear belt monitor malfunction Service required	The system has detected a fault that requires service. Have your vehicle checked as soon as possible.

Airbags

HOW DO THE FRONT AIRBAGS WORK

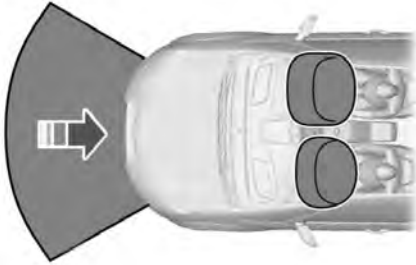

The front airbags are designed to deploy during a significant frontal or near-frontal crash. The airbags inflate within a few thousandths of a second cushioning forward body movement and deflate on contact with the occupant. The airbags are not designed to deploy during a minor frontal crash, rear crash, side crash or a vehicle rollover.

HOW DO THE SIDE AIRBAGS WORK

WARNING: Do not place objects or mount equipment on or near the airbag cover, on the side of the front or rear seatbacks, or in areas that may come into contact with a deploying airbag. Failure to follow these instructions may increase the risk of personal injury in the event of a crash.

WARNING: To reduce risk of injury, do not obstruct or place objects in the deployment path of the airbag.

WARNING: Do not lean your head on the door. The side airbag could injure you as it deploys from the side of the seatback.

WARNING: Accessory seat covers not released by Ford Motor Company could prevent the deployment of the airbags and increase the risk of injuries in a crash.



The side airbags are on the outermost side of each front and rear seat backrest. There is a label attached to the side of each backrest to indicate this.



Airbags

These airbags are designed to inflate between the door panel and the occupant to enhance the protection in certain crashes.

They are designed to deploy during a significant lateral crash. They could also deploy during a significant frontal crash, or a vehicle rollover. They are not designed to deploy during a minor lateral or frontal crash, or a rear crash.

Center Mounted Side Airbag (if Equipped)

The center mounted side airbag is on the innermost side of the driver seat. There is a label attached to the side of the backrest to indicate this.

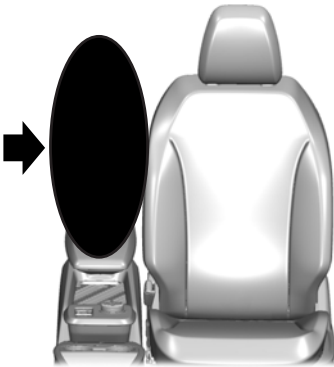

This airbag is designed to deploy during a significant lateral crash. It could also deploy during a significant frontal crash or a vehicle rollover. The airbag reduces contact between the driver and front seat passenger in side impacts and rollovers. The airbag is not designed to deploy during a minor lateral or frontal crash, or a rear crash.

HOW DO THE KNEE AIRBAGS WORK



WARNING: Do not attempt to open the airbag cover.

The driver knee airbag deploys during significant frontal and near frontal crashes that are up to 30° from the left or the right. The airbag inflates within a few thousandths of a second and deflates on contact with the occupants, thus providing a cushion between the driver's knees and the steering column. During overturns, rear crashes and side crashes, the knee airbag will not deploy.

Note: *The airbag has a lower deployment threshold than the front airbags. During a minor crash, it is possible that only the knee airbag deploys.*

HOW DOES THE SAFETY CANOPY™ WORK



WARNING: Do not place objects or mount equipment on or near the headliner at the siderail that may come into contact with a deploying curtain airbag. Failure to follow these instructions may increase the risk of personal injury in the event of a crash.

Airbags

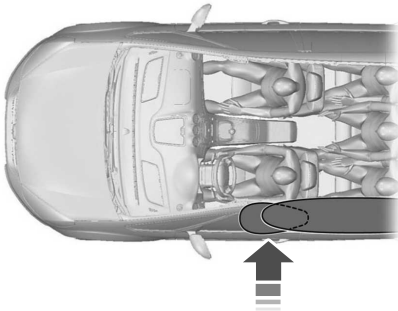

The airbags are above the front and rear side windows.

The airbags deploy during significant side crashes or when a certain likelihood of a rollover event is detected by the rollover sensor. In certain sideways crashes or rollover events, the airbags will be activated, regardless of which seats are occupied.

AIRBAG PRECAUTIONS



WARNING: Extreme Hazard! Never use a rearward facing child restraint on a seat protected by an active airbag in front of it. Death or serious injury to the child can occur.



WARNING: Do not modify the front of your vehicle in any way. This could adversely affect deployment of the airbags. Failure to adhere to this warning could result in serious personal injury or death.



WARNING: Wear a seatbelt and keep sufficient distance between yourself and the steering wheel. Only when you use the seatbelt correctly, can it hold you in a position that allows the airbag to achieve its optimum effect. Failure to adhere to this warning could result in serious personal injury or death.



WARNING: Repairs to the steering wheel, steering column, seats, airbags and seatbelts must be carried out by an authorized dealer. Failure to adhere to this warning could result in serious personal injury or death.



WARNING: Keep the areas in front of the airbags free from obstruction. Do not affix anything to or over the airbag covers. Objects could become projectiles during airbag deployment. Failure to follow this instruction could result in personal injury or death.



WARNING: Do not poke sharp objects into areas where airbags are fitted. This could damage and adversely affect deployment of the airbags. Failure to follow this instruction could result in personal injury or death.



WARNING: Accessory seat covers not released by Ford Motor Company could prevent the deployment of the airbags and increase the risk of injuries in a crash.



WARNING: Do not attempt to service, repair, or modify the supplementary restraint system or associated components. Failure to follow this instruction could result in personal injury or death.

Airbags



WARNING: If a supplementary restraint system component has deployed, it will not function again. Have the system and associated components inspected as soon as possible. Failure to follow this instruction could result in personal injury or death.

Note: A loud bang sounds and there is a cloud of harmless powdery residue if an airbag deploys. This is normal.

SWITCHING THE PASSENGER AIRBAG ON AND OFF

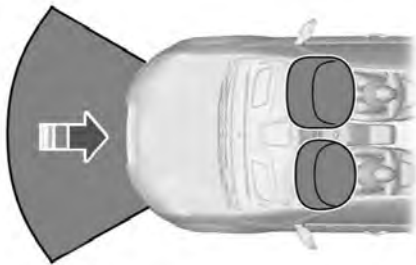

The airbag is designed to deploy during a significant frontal or near-frontal crash. The airbag inflates within a few thousandths of a second cushioning forward body movement and deflates on contact with the occupant. The airbag is not designed to deploy during a minor frontal crash, rear crash, side crash or a vehicle rollover.

Switching the Passenger Airbag Off



WARNING: You must switch the passenger airbag off when using a rearward facing child restraint on the front seat.

The switch is on the passenger side end of the instrument panel. The passenger airbag deactivation indicator is in the center console.



1. Insert the key blade into the key slot.



2. Turn the key to **OFF**.

Airbags

- When you switch the power on, check that the passenger airbag **OFF** indicator illuminates. If it does not illuminate when you switch the power on, this indicates a malfunction. Have your vehicle checked as soon as possible.

Switching the Passenger Airbag On



WARNING: You must switch the passenger airbag on following the removal of the child restraint.

- Insert the key blade into the key slot.



- Turn the key to **ON**.
- When you switch the power on, check that the passenger airbag **ON** indicator illuminates. If it does not illuminate when you switch the power on, this indicates a malfunction. Have your vehicle checked as soon as possible.

AIRBAGS – TROUBLESHOOTING

AIRBAGS – WARNING LAMPS



If it does not illuminate when you switch the power on, continues to flash or remains on when your vehicle is running, this indicates a malfunction. Have your vehicle checked as soon as possible.

AIRBAGS – AUDIBLE WARNINGS

Sounds when the airbag warning lamp is not working.

Pedestrian Protection

WHAT IS PEDESTRIAN PROTECTION

An advanced safety system that protects pedestrians during an impact with the vehicle. The bumper has sensors that can detect a pedestrian impact and trigger the deployable hood.

HOW DOES PEDESTRIAN PROTECTION WORK



The deployable hood system releases the hood hinges and raises the rear edge of the hood by about 10 cm (4 in). This increases the gap between the hood and the components within the front compartment. It provides additional cushioning in case the pedestrian makes contact with the hood.

The system has caution labels under the hood near the hood lifters.



These labels show the location of the hood lifters for service and emergency personnel.

The system is active when you drive between 20 km/h (12 mph) and 50 km/h (31 mph).

After an impact that has activated the system, the hood rises and remains permanently attached to the vehicle, by the hood hinges and latch. Do not drive the vehicle when the hood has been deployed. If the deployable hood system has been activated, stop the vehicle as soon as it is safe to do so, and transport the vehicle to the nearest authorized dealer.

You can open the hood using the hood latch after the deployable hood has been triggered. Make sure the hood is securely closed and latched before transporting the vehicle.

Note: Do not add any equipment to the front of the vehicle that is not authorized by us. This may include hood supports, hood pins or push bars.

PEDESTRIAN PROTECTION PRECAUTIONS

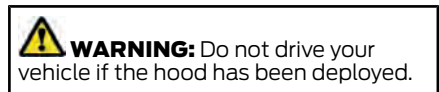

Pedestrian Protection



WARNING: Do not place your hand or objects or mount equipment on or near the hood lifters that may come into contact with a deploying hood lifter. Failure to follow these instructions may cause serious injury during a deployment.



WARNING: Do not attempt to service, repair, or modify the deployable hood system. Failure to follow this instruction could result in personal injury or death.



WARNING: If the deployable hood system activates, it will not function again. Have your vehicle checked as soon as possible. Failure to follow this instruction could result in personal injury or death.

PEDESTRIAN PROTECTION INDICATORS



If a fault is detected in the system, the monitoring system turns on the readiness indicator in the instrument cluster.

If the readiness lamp is lit, do not attempt to repair or service the system. Take your vehicle immediately to a qualified technician.

Pedestrian Alert System

WHAT IS THE PEDESTRIAN ALERT SYSTEM

[*Pedestrian Alert System Video Link*](#)

Due to the quiet operation of hybrid and electric vehicles at low speeds, the system creates a subtle sound to alert pedestrians.

The system is on when your vehicle is running and not in park (P). Some sound may be audible in the passenger compartment.

WHAT IS ECALL

eCall is an emergency call system that complies with European Union Regulation (EU) 2015/758.

The system uses the public cell phone network to initiate a call to the public emergency services when activated automatically in a severe accident or manually by the vehicle occupants.

eCall is designed for emergency calls in case of severe accidents or other emergencies that require the emergency services. It does not support other voice calls.

HOW DOES ECALL WORK

If an accident results in an attempt to deploy an airbag, excluding knee airbags and rear inflatable seatbelts, or to shut off the fuel pump, the system initiates a call to the emergency services. This call cannot be canceled.

In the case of an emergency, the system, as a means of communication aid, can help you contact specific rescue departments of public emergency services. The system does not deploy the rescue operations. The local public emergency service deploys specific rescue operations according to the actual situation.

During an emergency call, the system transmits vehicle data to the emergency service. See **Emergency Call System Data** (page 23).

Note: *If the transmission is unsuccessful, this could result in the emergency operator not receiving your vehicle data.*

Note: *If the system is unable to initiate a call to the emergency services, a voice prompt plays and the emergency call indicator illuminates.*

EMERGENCY CALL REQUIREMENTS

The system only operates in areas with a compatible cell phone network and emergency services infrastructure.

EMERGENCY CALL LIMITATIONS

Not all accidents activate the system. If an accident does trigger the system, it initiates a call to the emergency services. Do not wait for the system to initiate a call if you are able to do so. Call emergency services immediately to avoid a delayed response time. If you do not hear the system within five seconds of the accident, the system could be non-functional.

Using a non-Ford audio system could result in the system not properly operating.

MANUALLY MAKING AN EMERGENCY CALL



WARNING: Use caution when making a manual emergency call when driving.

1. Switch the ignition on.
2. Press the SOS symbol on the overhead console to open the emergency call button cover.
3. Press the emergency call button to initiate a call to the emergency services.

Note: *Press the button again before the call is connected to cancel it.*

4. Speak to the operator.

Note: After completing an emergency call, the emergency operator can call your vehicle. The system automatically answers incoming calls for approximately an hour.



The indicator is integrated into the emergency call button cover on the overhead console.

It illuminates brightly for a short time when you switch the ignition on.

EMERGENCY CALL INDICATORS



WARNING: If the system malfunctions, have your vehicle checked as soon as possible.

Emergency Call Indicator Status	Description
Indicator off.	The system has malfunctioned. Have your vehicle checked as soon as possible.
Dimmed red.	Normal operation.
Rapidly flashing.	The system is initiating an emergency call.
Moderately flashing.	The system is transmitting vehicle data to the emergency services.
Slowly flashing.	The system is connected to the emergency services and communication is established.
Bright red.	The system has malfunctioned. Have your vehicle checked as soon as possible.

eCall

CHANGING THE BACKUP BATTERY

The system has a backup battery and indicates when it needs to be changed. We recommend that you have the battery changed by an authorized dealer.

ECALL – TROUBLESHOOTING

ECALL – INFORMATION MESSAGES

Message	Description
Emergency Call System malfunction	The system has malfunctioned. Have your vehicle checked as soon as possible.

Keys and Remote Controls

REMOTE CONTROL LIMITATIONS

A valid remote control must be within one of the three external detection ranges. These are approximately 1 m (3 ft) from the front door handles and the tailgate.

The system could not function if:

- The remote control remains stationary for about a minute.
- The vehicle battery has no charge.
- The remote control battery has no charge.
- The remote control frequencies are jammed.
- The remote control is too close to metal objects or electronic devices, for example keys or a cell phone.

USING THE REMOTE CONTROL

Use your remote control to access various vehicle systems.

Note: *The buttons on your remote may vary depending on the vehicle region or options.*

One-Stage Unlocking



Press the button to unlock all doors. See **Unlocking and Locking the Doors Using the Remote Control** (page 74).

Two-Stage Unlocking (If Equipped)



Press the button to unlock the driver's door. Press the button again within three seconds to unlock all doors. See **Unlocking and Locking the Doors Using the Remote Control** (page 74).

Lock



Press the button to lock all doors. See **Unlocking and Locking the Doors Using the Remote Control** (page 74).

Front Luggage Compartment (If Equipped)



Press the button twice to open the front luggage compartment. See **Opening the Frunk Using the Remote Control** (page 296).

Liftgate



Press the button twice to open the liftgate.

LOCATING YOUR VEHICLE



Press the lock button twice within three seconds. The turn signal lamps flash. We recommend you use this method to locate your vehicle.

CHANGING THE REMOTE CONTROL BATTERY - LHD



WARNING: Keep batteries away from children to prevent ingestion. Failure to follow this instruction could result in personal injury or death. If ingested, immediately seek medical attention.

Keys and Remote Controls



WARNING: If the battery compartment does not securely close, stop using the remote control and replace it as soon as possible. In the meantime, keep the remote control away from children. Failure to follow this instruction could result in personal injury or death.

The remote control uses one coin-type 3-volt lithium battery, CR2450, or equivalent.



1. Push the release button and pull the key blade out.

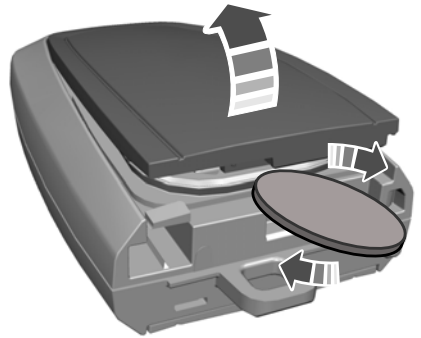
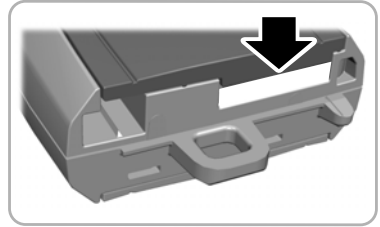

2. Twist a thin coin under the tab hidden behind the key blade head to remove the battery cover.

Keys and Remote Controls

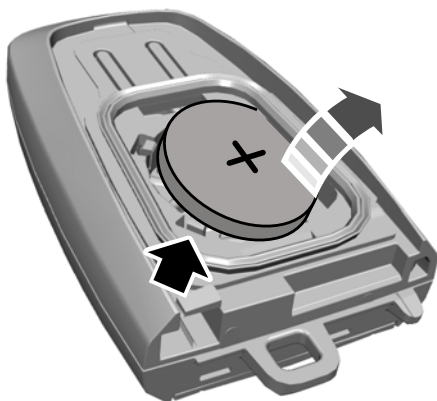

3. Insert a screwdriver in the position shown and carefully remove the battery.
4. Insert a new battery with the + facing upward.
5. Reinstall the battery cover onto the remote control and install the key blade.



Note: Refer to local regulations before you dispose of the remote control batteries.

Note: Do not wipe off any grease on the battery terminals or on the back surface of the circuit board.

Note: Replacing the remote control battery does not erase the programmed key from your vehicle. The remote control operates as normal.

Note: A message appears in the information display when the remote control battery is low.

CHANGING THE REMOTE CONTROL BATTERY - RHD (IF EQUIPPED)



WARNING: Keep batteries away from children to prevent ingestion. Failure to follow this instruction could result in personal injury or death. If ingested, immediately seek medical attention.



WARNING: If the battery compartment does not securely close, stop using the remote control and replace it as soon as possible. In the meantime, keep the remote control away from children. Failure to follow this instruction could result in personal injury or death.



CAUTION: The battery can cause severe or fatal injuries in two hours or less if swallowed or placed inside any part of the body. Seek medical attention immediately.



Make sure that you dispose of old batteries in an environmentally friendly way. Seek advice from your local authority about recycling old batteries.

The remote control uses one coin-type three-volt lithium battery CR2032 or equivalent.

Keys and Remote Controls

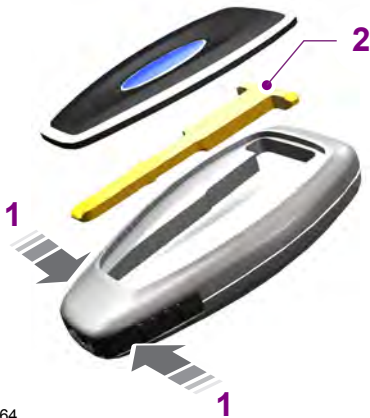

E87964

1. Press and hold the buttons on the edges of the transmitter to release the cover. Carefully remove the cover.
2. Remove the key blade from the transmitter.

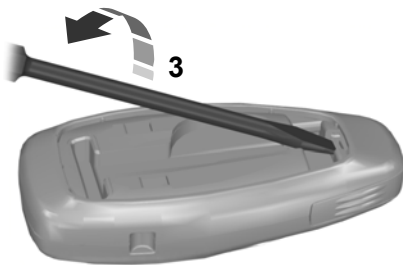

E105362

3. Use a suitable tool, for example a screwdriver, to carefully separate the two halves of the remote control.



E119190

4. Twist the screwdriver in the position shown to separate the two halves of the remote control.

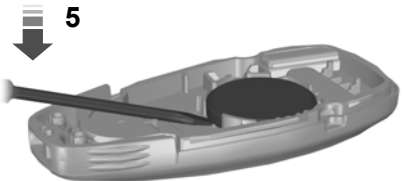

E125860

5. Carefully remove the battery with the screwdriver.
Note: Do not touch the battery contacts or the printed circuit board with the screwdriver.
6. Insert a new battery with the + facing downward.
Note: Do not wipe off any grease on the battery terminals or on the back surface of the circuit board.
7. Assemble the two halves of the remote control.
8. Reinstall the key blade.

Keys and Remote Controls

REPLACING A LOST KEY OR REMOTE CONTROL

You can purchase replacement keys or remote controls from an authorized dealer. Authorized dealers can program remote controls for your vehicle.

PROGRAMMING THE REMOTE CONTROL

Contact an authorized dealer to program remote controls for your vehicle.

KEYS AND REMOTE CONTROLS – TROUBLESHOOTING

KEYS AND REMOTE CONTROLS – INFORMATION MESSAGES

Message	Action
Key battery low Replace soon	Replace remote control battery.

Phone as a Key

WHAT IS PHONE AS A KEY

[Phone as a Key with Walk Away Locking](#)

Phone as a Key allows you to use your phone in place of a passive key.

You can use your phone for the following functions:

- Remote locking and unlocking.
- Passive entry and exit.
- Passive start and drive the vehicle.
- Remote start.
- Memory function recall.

PHONE AS A KEY LIMITATIONS

Limitations can vary based on the make and model of your phone, phone location and physical obstructions.

The following items could impact Phone as a Key performance or prevent functionality in some cases:

- The typical operating range for Phone as a Key is 40 m (131 ft).
- Your **Bluetooth®** connection is not enabled, is disrupted, or out of range.
- Your Phone as a Key is not active or enabled on at least one phone.
- Your vehicle battery has depleted.
- Your phone battery has depleted.
- Interference from other devices using radio frequencies or physical obstructions.
- Your phone is too close to metal objects or other electronic devices.

Note: *Do not leave a duplicate coded key in the vehicle. Always take your keys and phone and lock all doors when leaving the vehicle.*

PROGRAMMING YOUR PHONE

To program your smartphone as phone as a key:

1. Visit your device's app store to download the FordPass app.
2. Create a new account or sign-in to an existing account on the FordPass app.
3. Add the vehicle identification number to your account and follow the prompts in the FordPass app to complete the Sync Connect Authorization process.
4. After the authorization is complete, you can set up phone as a key following the prompts in the FordPass app.
5. After phone as a key is set up, you can set up the backup start passcode by following the prompts on your touchscreen.

Note: *Keep your new backup start passcode with you in case of an emergency.*

Resetting Phone as a Key

1.  Press the button on the touchscreen.
2. Press **General**.
3. Press **Reset**.
4. Press the app connect reset option.
5. Press **Reset all**.
6. Confirm you would like to continue with erasing all phone as a key settings, keys and backup start passcodes.
7. Press **Continue**.
8. Confirm you are aware you are de-authorizing all authorized users and FordPass Connect settings.
9. Press **Continue**.

Phone as a Key

USING THE VALET MODE

Classic Valet Mode

Enabling Valet Mode

Make sure the remote control is in your vehicle.

1.  Press the profile button on the touchscreen.

Note: The button image may vary when a profile is selected.

2. Press **Valet Mode**.
3. Enter a four digit code to lock the touchscreen.
4. Re-enter the same four digit code to complete enabling valet mode.

Disabling Valet Mode

1. Press **Exit Valet Mode**.
2. Enter your four digit code to disable valet mode and unlock your touchscreen.

Enhanced Valet Mode

Enabling Valet Mode

Have your backup start passcode completely set up before using valet mode. See **Programming Your Phone** (page 65).

Note: If your vehicle detects a remote control, the system defaults to classic valet mode.

1.  Press the profile button on the touchscreen.

Note: The button image may vary when a profile is selected.

2. Press **Valet Mode**.

Note: If the system detects a valid phone as a key, a valet passcode displays in both the touchscreen and mobile app.

Note: If the system does not detect a valid phone as a key, it prompts you to enter your backup start passcode on the touchscreen. Once validated, a valet passcode displays on the touchscreen.

3. Provide the valet the first seven digits of the valet passcode to enter on the keyless entry keypad to unlock your vehicle.
4. Provide the valet the 10-digit valet passcode to enter on the touchscreen to start and drive your vehicle.

Disabling Valet Mode

1. Press **Exit Valet Mode**.

Note: If the system detects an authorized phone as a key, valet mode disables.

Note: If the system does not detect a valid phone as a key, it prompts you to enter your backup start passcode. Once validated, valet mode disables.

USING THE BACKUP START PASSCODE

Make sure you have phone as a key active on at least one phone to use a previously created backup start passcode. See **Programming Your Phone** (page 65).

1. Press the brake pedal and the push button start. If the system does not detect a valid phone as a key or remote control, a message appears on the touchscreen and prompts you for your backup start passcode.

Note: The touchscreen times out after 30 seconds with no interaction.

Note: If the backup start passcode screen does not appear, press the brake pedal and push button start again.

Phone as a Key

2. Use the touchscreen to enter your backup start passcode.
3. After entering your passcode, press return within 30 seconds.
4. Once the system validates the backup start passcode, a message alerts you to start your vehicle.
5. Press the brake pedal and the push button start within 20 seconds to start the vehicle.
6. If your vehicle does not start, repeat steps 1-5.

System Lockout

The system locks after five combined incorrect attempts of the following:

- Entering a backup start passcode.
- Resetting a current passcode.
- Entering a valet mode passcode.

Note: *The system remains locked for five minutes. After five minutes the system allows codes to be entered again.*

PHONE AS A KEY – TROUBLESHOOTING

PHONE AS A KEY – FREQUENTLY ASKED QUESTIONS

How can I tell if my vehicle has phone as a key?

- The touchscreen shows the phone as a key reset option.
- A control button appears on the home screen of the FordPass app if you have registered your vehicle through the FordPass app.

What happens if I cannot unlock the vehicle with phone as a key?

- Attempt to move your phone closer to the vehicle.
- Check that the FordPass app is still running and that the phone as a key control screen shows connected. If the phone is connected, attempt to press the remote unlock button in the FordPass app. If the phone is not connected or the remote unlock button does not work in the FordPass app, attempt to force close and restart the app.

Why do I get a No Key Detected message in the instrument cluster display when I am using phone as a key and my phone is in the car?

- Your phone's Bluetooth connection has been disrupted or is not connected. Try reconnecting your phone's Bluetooth connection.
- Move the phone closer to the center of the vehicle near the cup holder or center console.
- Verify your phone as a key is still active, enabled and has not been revoked.

What do I do if my phone is lost, damaged or the battery has depleted?

- Use the backup start passcode that you created. See **Using the Backup Start Passcode** (page 66).

How many phones can I use for phone as a key?

- You can program and activate up to four phones with phone as a key to your vehicle.

Phone as a Key

How does a valet drive my car if I only use my phone as a key?

- Have the valet use the temporary valet passcode that you created. See **Using the Valet Mode** (page 66).

I uninstalled my FordPass app and reinstalled it. Why am I not able to get a new phone as a key?

- Remove the phone as a key that was previously associated with your phone.
- Reset phone as a key from your vehicle, and then request a new phone as a key. See **Programming Your Phone** (page 65).

Why can I not remotely start the vehicle with my phone as a key?

- Using the FordPass app, verify your phone as a key setup is complete and enabled via Bluetooth connection on at least one phone. If Bluetooth has connected but phone as a key setup is not complete, complete the setup of your phone as a key as prompted from the FordPass app. See **Programming Your Phone** (page 65).

WHAT IS MYKEY

MyKey allows you to program keys with restricted driving modes to promote good driving habits.

You can program the restrictions to all keys except one. Any keys that you did not program are administrator keys or admin keys.

Note: Every MyKey receives the same restrictions and settings. You cannot program them individually.

MYKEY SETTINGS

NON-CONFIGURABLE MYKEY SETTINGS

Seatbelt Reminder or Belt-Minder™

MyKey mutes the audio system until the front seat passengers buckle the front seat belts.

Note: If your vehicle includes an AM/FM radio or a very basic audio system, the radio may not mute.

Early Low Fuel

The low fuel level warning lamp turns on earlier.

Driving and Parking Aids

You cannot configure settings for parking aids, blind spot information system, and cross traffic alert. These systems turn on when the vehicle turns on, and you cannot switch them off with a MyKey.

You cannot configure settings for pre-collision assist and lane keeping. These systems turn on when the vehicle turns on.

A new destination in the navigation system can only be set using voice commands when using a MyKey, and with your vehicle moving.

Note: MyKey drivers may be able to switch the lane keeping assist off, but this feature turns back on automatically with every new key cycle.

CONFIGURABLE MYKEY SETTINGS

You can configure the following settings after creating a MyKey. See **Creating a MyKey** (page 70).

Speed Limit



WARNING: Do not set MyKey maximum speed limit to a limit that will prevent the driver from maintaining a safe speed considering posted speed limits and prevailing road conditions. The driver is always responsible to drive in accordance with local laws and prevailing conditions. Failure to do so could result in accident or injury.

You can set a speed limit for your vehicle. Warning messages appear on the touchscreen and a tone sounds if your vehicle reaches the set speed. You cannot override the set speed when using a MyKey.

Speed Minder

You can set a speed reminder for your vehicle. Warning messages appear on the touchscreen and a tone sounds if your vehicle exceeds the set speed.

Audio System Volume Limit

The audio system maximum volume reduces. A message appears on the touchscreen if you attempt to exceed the volume limit. Automatic volume control turns off.

Emergency Assistance

If you set emergency assistance to always on, you cannot switch it off with a MyKey.

Do Not Disturb

If you set do not disturb to always on, you cannot switch it off with a MyKey.

Note: *If a phone is connected using Apple CarPlay or Android Auto while driving with a MyKey, the driver can receive phone calls and text messages even if the do not disturb restriction is on.*

Traction and Stability Control

If you set traction control or stability control to always on, you cannot switch it off with a MyKey.

CREATING A MYKEY

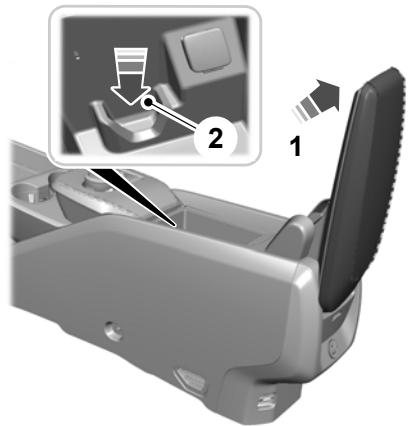

Note: *You can use these instructions to create a MyKey for either a passive key or a mobile device.*

1. Raise the center console storage compartment lid.
2. Remove the key blade from the remote control and place the remote control in the position shown.
3. Switch the ignition on using the key you want to create as MyKey.
4.  Press the button on the touchscreen.
5. Press **Vehicle**.
6. Press **MyKey**.
7. Press **Create MyKey** or **Create MyKey Mobile Device**.
8. Press **Yes**.
9. Switch the ignition off.

Note: You successfully created a MyKey. We recommend that you label this key so you can distinguish it from the admin keys.

Note: You can use both a passive key and a mobile device as a MyKey. You must have a second passive key and create it as a MyKey.

Note: The programmed restrictions apply when you switch the vehicle off, open and close the driver door and restart your vehicle with the passive key or mobile device.

PROGRAMMING A MYKEY

You can program any remote control to become a restricted MyKey, but you must leave one unmodified as an admin key.

1. Switch the vehicle on using an admin key.
2.  Press the button on the touchscreen.
3. Press **Vehicle**.
4. Press **MyKey**.
5. Select and configure the settings.

CLEARING ALL MYKEYS

When you clear all MyKeys, you remove all restrictions and return all MyKeys to their original admin key status.

1.  Press the button on the touchscreen.
2. Press **Vehicle**.
3. Press **MyKey**.
4. Press **Clear all MyKeys**.
5. Press **Yes**.

CHECKING MYKEY SYSTEM STATUS

You can find information about the distance traveled using a MyKey, and the number of admin keys and MyKeys created for your vehicle.

1. Switch the vehicle on.
2.  Press the button on the touchscreen.
3. Press **Vehicle**.
4. Press **MyKey**.
5. Press **MyKey Information**.

MYKEY – TROUBLESHOOTING

MYKEY – INFORMATION MESSAGES

Message	Description
Place key in backup location	Displays when trying to create a MyKey and the admin key is not placed in the backup position. See Creating a MyKey (page 70).
Key is already a MyKey	Displays when trying to create a MyKey with a key already designated as a MyKey.
Key restricted at next start. Label this key	Displays to confirm that the key is restricted after you switch the ignition off.

MYKEY – FREQUENTLY ASKED QUESTIONS

What is an admin key?

An admin key is a key that you have not created as a MyKey. See **Creating a MyKey** (page 70).

Why am I not able to create a MyKey?

You have not placed the admin key in the backup position. See **Creating a MyKey** (page 70). The key used to switch the ignition on is not an admin key. The key used to switch the ignition on is the only admin key. There has to be at least one admin key. You did not switch the ignition off after creating the last MyKey.

Why am I not able to program a MyKey?

The admin key is not inside your vehicle. The key used to switch the ignition on is not an admin key. You have not created any MyKeys. See **Creating a MyKey** (page 70).

Why am I not able to clear the MyKeys?

The admin key is not inside your vehicle. The key used to switch the ignition on is not an admin key. You have not created any MyKeys. See **Creating a MyKey** (page 70).

Why is the MyKey distance not accumulating?

The key used to start the engine is an admin key. An admin key and a MyKey are inside your vehicle. You have not created any MyKeys. See **Creating a MyKey** (page 70). You have cleared the MyKeys. See **Clearing All MyKeys** (page 71).

Why am I not able to start the engine with a MyKey?

An admin key and a MyKey are inside your vehicle. The system recognizes only the admin key when both are present.

Doors and Locks

OPERATING THE DOORS FROM OUTSIDE YOUR VEHICLE

UNLOCKING AND LOCKING THE DOORS USING THE REMOTE CONTROL

You can only use the remote control when your vehicle is stationary.

Unlocking the Doors



Press the button to unlock all doors. One long flash of the turn signal lamps confirms that your vehicle has unlocked.

Locking the Doors



Press the button to lock all doors. One short flash of the turn signal lamps confirms that your vehicle has locked.

OPENING AND CLOSING THE DOORS

E-Latch

Note: For more information on operating the doors from outside your vehicle See *Keyless Entry* (page 78).

OPERATING THE DOORS FROM INSIDE YOUR VEHICLE

UNLOCKING AND LOCKING THE DOORS USING THE CENTRAL LOCKING

The power door lock control is on the front doors.



Press the button to unlock all doors.



Press the button to lock all doors.

Note: The central locking only operates if the front doors are fully closed.

OPENING THE DOORS FROM INSIDE YOUR VEHICLE

E-Latch

Pull the interior door handle twice to unlock and open a rear door. The first pull unlocks the door and the second pull opens the door.

AUTOUNLOCK

WHAT IS AUTOUNLOCK

Autounlock is an unlocking feature that unlocks the vehicle doors when your vehicle comes to a stop.

AUTOUNLOCK REQUIREMENTS

Autounlock unlocks all the doors after all of the following occur.

1. All the doors are closed and your vehicle is moving at a speed greater than 20 km/h (12 mph).
2. Your vehicle comes to a stop.
3. You open the driver door within 10 minutes of switching the ignition off or to the accessory position.

Note: If you open the driver door after 10 minutes, Autounlock does not unlock all other doors.

Doors and Locks

AUTOLOCK

WHAT IS AUTOLOCK

Autolock is a locking feature that locks your vehicle doors when you start driving.

AUTOLOCK REQUIREMENTS

Autolock locks all the doors when all of the following occur:

- All doors are closed.
- The vehicle is on.
- Your vehicle reaches a speed greater than 20 km/h (12 mph).

MISLOCK

WHAT IS MISLOCK

Mislock is a locking feature that warns you if your vehicle has not locked.

MISLOCK LIMITATIONS

When you press the lock button once, the direction indicators do not flash if:

- Any door or the liftgate is open.
- The hood is open.

The horn sounds when you press the lock button on the remote control a second time within 3 seconds and a door is open.

If you switch mislock off, the horn does not sound if you press the lock button on the remote control when a door is open.

SWITCHING MISLOCK ON AND OFF

1.  Press the button on the touchscreen.
2. Press **Vehicle**.
3. Press **Locks**.
4. Switch **Mislock** on or off.

DOORS AND LOCKS AUDIBLE WARNINGS

Door Ajar Audible Warning

Sounds when a door is not fully closed and your vehicle is moving.

DOORS AND LOCKS – TROUBLESHOOTING

DOORS AND LOCKS – WARNING LAMPS

Door Ajar Warning Lamp



It illuminates when you switch the vehicle on and remains on if any door is open.

Doors and Locks

DOORS AND LOCKS – INFORMATION MESSAGES

Message	Action
Driver door open	Displays if a door is open. Fully close the door.
Passenger door open	
Rear left door open	
Rear right door open	
Bonnet open	Displays if a hood is open. Fully close the hood.

Doors and Locks

DOORS AND LOCKS – FREQUENTLY ASKED QUESTIONS

How to unlock my vehicle if the 12 volt battery is dead?

You must apply 12 volt power to the 12 volt system. See **Jump Starting the Vehicle** (page 314).

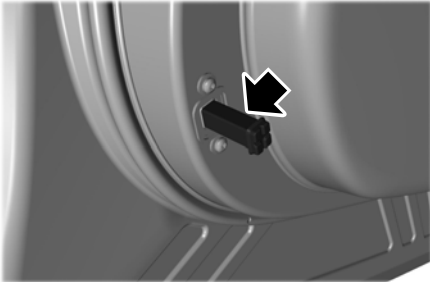

How to close my door if the actuator is extended?

Apply pressure by pushing the outside of the door until the door closes.

Keyless Entry

WHAT IS KEYLESS ENTRY

The system allows you to lock and unlock your vehicle without taking the passive key out of your pocket or purse.

KEYLESS ENTRY LIMITATIONS

Make sure your remote control is within 1 m (3 ft) from the front door handles and the tailgate.

The system could not function if:

- The remote control remains stationary for about a minute.
- The vehicle battery has no charge.
- The remote control battery has no charge.
- There is interference causing issues with the remote control frequencies.
- The remote control is too close to metal objects or electronic devices, for example keys or a cell phone.

KEYLESS ENTRY SETTINGS

Switching Keyless Entry On and Off

1. With the admin key in the vehicle, fully press the brake pedal and press the push button start.
2.  Press the button on the touchscreen.
3. Press **Vehicle**.
4. Press **Locks**.
5. Press and hold the **OK** button until the system reset confirmation appears.

Reprogramming the Unlocking Function

You can enable two-stage unlocking function allowing you to unlock only the driver door when you touch the unlock sensor.

Press and hold both the lock and unlock buttons on the remote control for four seconds to disable or enable two-stage unlocking.

If you program the unlocking function so that only the driver door unlocks, you can unlock all of the other doors from inside your vehicle using the power door lock control. You can unlock individual doors by pulling the interior door handles on those doors.

USING KEYLESS ENTRY

Unlocking the Doors

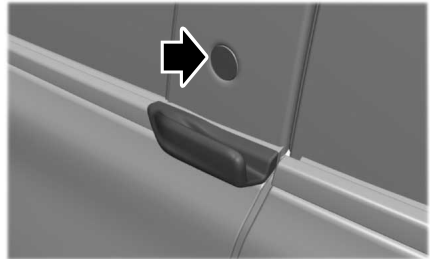

With your passive key or authorized phone within 1 m (3 ft) of your vehicle, gently press the touchpad on the door window trim to unlock and open the door.

Keyless Entry

Opening the Liftgate with Passive Key (If Equipped)



Press the exterior liftgate release button inside of the liftgate handle. The liftgate unlocks and opens. See **Opening the Liftgate From Outside Your Vehicle** (page 92).

Locking the Doors

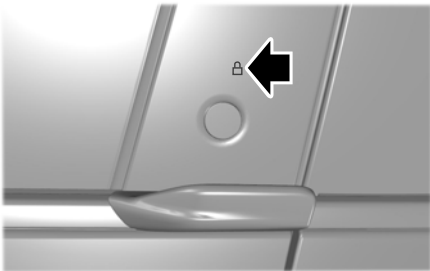

With your remote control or authorized phone within 1 m (3 ft) of your vehicle, touch the lock icon on the door window trim to lock the door. The keyless entry system requires a brief delay to authenticate your device.

Note: The door activation switch flashes one time to indicate the vehicle locks.

Note: Do not use the outside door handle as a roof cargo strap.

Double Locking

With your remote control or authorized phone within 1 m (3 ft) of your vehicle, touch the lock icon twice within three seconds to double lock your vehicle.

KEYLESS ENTRY – TROUBLESHOOTING

KEYLESS ENTRY – FREQUENTLY ASKED QUESTIONS

Why does the passive key not work?

The system deactivates passive keys left inside your vehicle when you lock it. You cannot switch the ignition on using a deactivated passive key. Press the unlock button on the remote control to reactivate a passive key.

Keyless Entry Keypad

WHAT IS THE KEYLESS ENTRY KEYPAD

The keyless entry keypad allows you to lock and unlock your vehicle using the keypad on the window trim.

KEYLESS ENTRY KEYPAD LIMITATIONS

The system may not function if:

- The vehicle battery has no charge.

LOCATING THE KEYLESS ENTRY KEYPAD

The keypad is near the driver window and illuminates when you touch it.

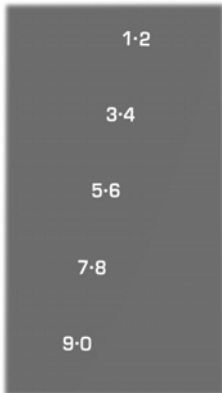

KEYLESS ENTRY KEYPAD MASTER ACCESS CODE

What Is the Master Access Code

The master access code is a factory-set seven-digit entry code. You can operate the keypad with the master access code at any time. The master access code is on the owner's wallet card in the glove box and is available from an authorized dealer.

KEYLESS ENTRY KEYPAD PERSONAL ACCESS CODES

Programming a Personal Entry Code

1. Enter the factory-set seven-digit code.
2. Press **1-2** on the keypad within five seconds.
3. Enter your personal seven-digit code. You must do this within five seconds of completing Step 2.
4. Press **1-2** on the keypad to save personal code 1.

The doors lock then unlock to confirm that programming was successful.

To program additional personal entry codes, repeat Steps 1 through 3, then for Step 4:

- Press **3-4** to save personal code 2.
- Press **5-6** to save personal code 3.
- Press **7-8** to save personal code 4.
- Press **9-0** to save personal code 5.

If your vehicle comes with SYNC, you can also program the system with a personal entry code.

Keyless Entry Keypad

Hints:

- Do not set a code that uses seven of the same number.
- Do not use seven numbers in sequential order.
- The factory-set code works even if you have set your own personal code.

Erasing a Personal Code

1. Enter the factory-set seven-digit code.
2. Press and release **1-2** on the keypad within five seconds.
3. Press and hold **1-2** for two seconds. You must do this within five seconds of completing Step 2.

All personal codes erase and only the factory-set seven-digit code works.

Anti-Scan Feature

The keypad goes into an anti-scan mode if you enter the wrong code seven times. This mode turns off the keypad for one minute and the keypad lamp flashes.

The anti-scan feature turns off after:

- One minute of keypad inactivity.
- You press the unlock button on the remote control.
- You switch the ignition on.
- You unlock your vehicle using intelligent access.

USING THE KEYLESS ENTRY KEYPAD

Enter the factory-set seven-digit code or your personal code. You must press each number within five seconds of each other. The interior lamps illuminate.

Note: All doors unlock if you disable the two-stage unlocking feature. To disable the two-stage unlocking feature:

1. Switch the vehicle on using an admin key.
2.  Press the button on the touchscreen.
3. Press **Vehicle**.
4. Press **Locks**.
5. Press and hold the **OK** button until a confirmation message appears in the information display.

To Unlock All Doors

Enter the factory-set code or your personal code, then press **3-4** within five seconds.

Locking the Doors



Press and hold **7-8** and **9-0** at the same time with the driver door closed.

Note: You do not need to enter the code first.

Double Locking

Press and hold **7-8** and **9-0** twice within 3 seconds with your passive key in range to double lock your vehicle.

Keyless Entry Keypad

If your remote control battery is depleted you can also enter your keypad code first, followed by pressing **7-8** and **9-0** twice within 3 seconds to double lock your vehicle.

KEYLESS ENTRY KEYPAD – TROUBLESHOOTING

KEYLESS ENTRY KEYPAD – FREQUENTLY ASKED QUESTIONS

Why does the keypad not accept the access code?

If you enter the access code too fast on the keypad, the unlock function may not work. Slowly re-enter the access code.

Why does the keypad not function?

The keypad goes into an anti-scan mode if you enter a wrong code seven times. The anti-scan mode disables the keypad for one minute and the red light flashes.

Walk Away Lock

WHAT IS WALK AWAY LOCK

[*Phone as a Key with Walk Away Locking*](#)

Walk away lock is a locking feature that locks the vehicle when you walk away from the vehicle with the passive key or authorized phone.

HOW DOES WALK AWAY LOCK WORK

Walk Away Lock will lock all the doors when all of the following are met:

- The vehicle is off.
- All doors and luggage compartments have been closed and unlocked.
- A door or luggage compartment has been opened and closed without a lock or unlock occurring after all doors or luggage compartments have been closed.
- Any passive key or authorized phone is not inside the vehicle.
- More than 150 seconds has elapsed.

WALK AWAY LOCK LIMITATIONS

Walk Away Lock does not lock all the doors when following occur:

- The vehicle is on.
- All doors are closed and locked.
- Any of the doors or luggage compartments are open.
- Any passive key or authorized phone is inside the vehicle.

SWITCHING WALK AWAY LOCK ON AND OFF

1.  Press the button on the touchscreen.
2. Press **Vehicle**.
3. Press **Locks**.
4. Switch **Walk Away Lock** on or off.

Easy Entry and Exit

HOW DOES EASY ENTRY AND EXIT WORK

This feature moves the driver seat rearward up to 5 cm (2 in) when you switch the ignition off. The driver seat returns to its previous position when you switch the ignition on.

SWITCHING EASY ENTRY AND EXIT ON AND OFF

1.  Press the button on the touchscreen.
2. Press **Vehicle**.
3. Press **Easy Entry/Exit**.
4. Switch **Easy entry/exit** on or off.

If you press any adjustment or memory button when in easy exit mode, the system cancels the operation.

Liftgate - Vehicles With: Hands-Free Liftgate/Power Liftgate

LIFTGATE PRECAUTIONS



WARNING: It is extremely dangerous to ride in a cargo area, inside or outside of a vehicle. In a crash, people riding in these areas are more likely to be seriously injured or killed. Do not allow people to ride in any area of your vehicle that is not equipped with seats and seatbelts. Make sure everyone in your vehicle is in a seat and properly using a seatbelt. Failure to follow this warning could result in serious personal injury or death.



WARNING: Keep keys out of reach of children. Do not allow children to operate or play near an open or moving power liftgate. You should supervise the operation of the power liftgate at all times.

Note: Do not hang anything, for example a bike rack, from the glass or liftgate. This could damage the liftgate and its components.

Note: Do not leave the liftgate open when you are driving. This could damage the liftgate and its components.

OPENING THE LIFTGATE FROM OUTSIDE YOUR VEHICLE

1. Unlock the liftgate using an authorized device.



Note: If an authorized device is within 1 m (3 ft) of the liftgate, the liftgate unlocks when you press the liftgate release button.



OPENING THE LIFTGATE

OPENING THE LIFTGATE FROM INSIDE YOUR VEHICLE

With the transmission in park (P), access the liftgate settings on the touchscreen.

1.  Press the button on the touchscreen.
2. Press **CONTROLS**.
3.  Press the liftgate icon.

Note: Be careful when opening or closing the liftgate in a garage or other enclosed area to avoid damaging the liftgate.

2. Press and release the liftgate control button.

Note: Allow the power system to open the liftgate. Manually pushing or pulling the liftgate may activate the system's obstacle detection feature and stop the power operation or reverse its direction, replicate a strut failure, or damage mechanical components.

Note: Be careful when opening or closing the liftgate in a garage or other enclosed area to avoid damaging the liftgate.

Liftgate - Vehicles With: Hands-Free Liftgate/Power Liftgate

Note: Do not hang anything, for example a bike rack, from the glass or liftgate. This could damage the liftgate and its components.

Note: Do not leave the liftgate open while driving. This could damage the liftgate and its components.

Switching the Power Liftgate On or Off

You can switch the power liftgate on or off through the vehicle settings on your touchscreen.

When switched off, the liftgate only unlatches and will not power open or close.

OPENING THE LIFTGATE USING THE REMOTE CONTROL



Press the button twice within three seconds.

Note: Be careful when opening or closing the liftgate in a garage or other enclosed area to avoid damaging the liftgate.

Note: Do not hang anything, for example a bike rack, from the glass or liftgate. This could damage the liftgate and its components.

Note: Do not leave the liftgate open while driving. This could damage the liftgate and its components.

OPENING THE HANDS-FREE LIFTGATE (If Equipped)

Make sure you have the authorized device within 1 m (3 ft) of the liftgate.

1. Stand behind your vehicle, and face the liftgate.
2. Move your foot, in a single-kick motion, without pausing, under and away from the rear bumper detection area.

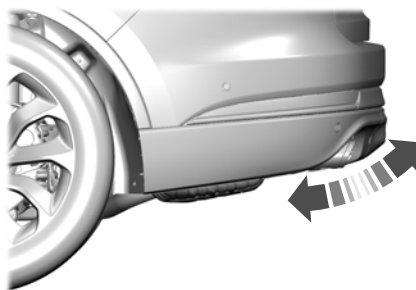

3. The liftgate opens.

Avoid the following actions when using the hands-free opening feature:

- Making physical contact with the bumper.
- Holding your foot under the bumper.
- Sweeping your foot from side to side, or kicking at an odd angle.

Detection Zones



The detection area is in the center of the rear bumper.

Note: Allow the power system to open the liftgate. Manually pulling the liftgate may activate the system's obstacle detection feature and stop the power operation or reverse its direction, replicate a strut failure, or damage mechanical components.

Liftgate - Vehicles With: Hands-Free Liftgate/Power Liftgate

Note: Any physical actions that mimic a kicking motion such as splashing water, trailer chains or vacuum hoses may cause the hands-free liftgate to activate. Switch the power liftgate off through your vehicle settings or keep the authorized device away from the rear bumper detection area.

SETTING THE LIFTGATE OPENING HEIGHT

1. Open the liftgate.
2. Stop the liftgate movement by pressing the control button on the liftgate when it reaches the desired height.

Note: Once the liftgate stops moving, you can manually move it to the desired height.

3. Press and hold the control button on the liftgate until a tone sounds, indicating programming is complete.

Note: You can only use the liftgate control button to program the height.

Note: You cannot program the height if the liftgate position is too low.

4. The power liftgate now opens at the programmed height. To change the programmed height, repeat the steps.

Note: You can fully open the liftgate by manually pushing it upward to the maximum open position if it opens in a lower position.

Note: The system recalls the new programmed height until you reprogram it, even if you disconnect the battery.



CLOSING THE LIFTGATE

CLOSING THE LIFTGATE FROM INSIDE YOUR VEHICLE



WARNING: Make sure all persons are clear of the power liftgate area before using the power liftgate control.

With the transmission in park (P), access the liftgate settings on the touchscreen.

1.  Press the button on the touchscreen.
2. Press **CONTROLS**.
3.  Press the liftgate icon.

Note: Make sure that you close the liftgate before operating or moving your vehicle, especially in an enclosure, like a garage or a parking structure. This could damage the liftgate and its components.

Note: Make sure the area behind your vehicle is free from obstruction and that there is enough room for you to operate the liftgate. The liftgate could come into contact with objects too close to your vehicle, for example a wall, garage door or another vehicle. This could damage the liftgate and its components.

Note: Make sure that you fully close the liftgate to prevent cargo from falling out.

CLOSING THE LIFTGATE FROM OUTSIDE YOUR VEHICLE



WARNING: Make sure all persons are clear of the power liftgate area before using the power liftgate control.

Liftgate - Vehicles With: Hands-Free Liftgate/Power Liftgate

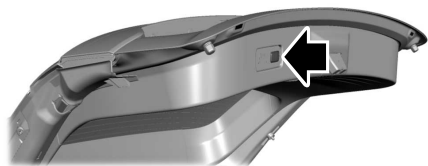

Press and release the liftgate button. A tone sounds when the liftgate begins to close.

Note: Make sure that you close the liftgate before operating or moving your vehicle, especially in an enclosure, like a garage or a parking structure. This could damage the liftgate and its components.

Note: Make sure the area behind your vehicle is free from obstruction and that there is enough room for you to operate the liftgate. Objects too close to your vehicle, for example a wall, garage door or another vehicle may come into contact with the moving liftgate. This could damage the liftgate and its components.

Note: Make sure you fully close the liftgate to prevent cargo from falling out.

CLOSING THE LIFTGATE USING THE REMOTE CONTROL



WARNING: Make sure all persons are clear of the power liftgate area before using the power liftgate control.



Press the button twice within three seconds.

Note: Make sure that you close the liftgate before operating or moving your vehicle, especially in an enclosure, like a garage or a parking structure. This could damage the liftgate and its components.

Note: Make sure the area behind your vehicle is free from obstruction and that there is enough room for you to operate the liftgate. Objects too close to your vehicle, for example a wall, garage door or another vehicle may come into contact with the moving liftgate. This could damage the liftgate and its components.

Note: Make sure that you fully close the liftgate to prevent cargo from falling out.

CLOSING THE HANDS-FREE LIFTGATE (if Equipped)

Make sure you have the authorized device within 1 m (3 ft) of the liftgate.

1. Stand behind your vehicle, and face the liftgate.
2. Move your foot, in a single-kick motion, without pausing, under and away from the rear bumper detection area.

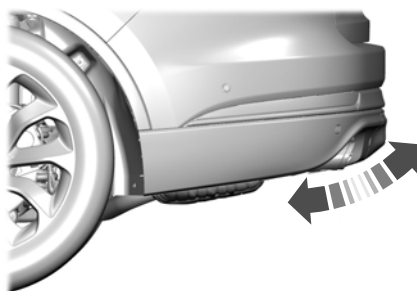

3. The liftgate closes.

Note: A tone sounds when the liftgate begins to close.

Avoid the following actions when using the hands-free feature:

Liftgate - Vehicles With: Hands-Free Liftgate/Power Liftgate

- Making physical contact with the bumper.
- Holding your foot under the bumper.
- Sweeping your foot from side to side, or kicking at an odd angle.

Detection Zones



The detection area is in the center of the rear bumper.

Note: Allow the power system to close the liftgate. Manually pushing the liftgate may activate the system's obstacle detection feature and stop the power operation or reverse its direction, replicate a strut failure, or damage mechanical components.

STOPPING THE LIFTGATE MOVEMENT

Note: Do not apply sudden excessive force to the liftgate while it is in motion. This could damage the power liftgate and its components.

Note: Selections will vary depending on region or options.

You can stop the liftgate movement by doing any of the following:

- Pressing the liftgate control button on the liftgate.
- Pressing the liftgate control button inside the vehicle.
- Pressing the liftgate button on the remote control twice.
- Pressing the liftgate button on an authorized device.
- Moving your foot under and away from the center rear bumper in a single-kick motion.

LIFTGATE OBSTACLE DETECTION

[Power Liftgate Obstacle Detection](#)

Closing the Liftgate

The system stops when it detects an obstacle. A tone sounds and the system reverses to open. Once you remove the obstacle, you can power close the liftgate.

Note: To prevent accidental obstacle detection, let the power liftgate close completely before you enter your vehicle.

Opening the Liftgate

The system stops when it detects an obstacle and a tone sounds. Once you remove the obstacle, you can continue to operate the liftgate.

LIFTGATE – TROUBLESHOOTING

LIFTGATE – WARNING LAMPS



Illuminates when the liftgate is not completely closed.

Liftgate - Vehicles With: Hands-Free Liftgate/Power Liftgate

LIFTGATE – INFORMATION MESSAGES

Message	Action
Liftgate open	The liftgate is not completely closed. Close the liftgate.

Liftgate - Vehicles With: Hands-Free Liftgate/Power Liftgate

LIFTGATE – FREQUENTLY ASKED QUESTIONS

Why won't my power liftgate function?

It can happen in freezing conditions or when parking on downhill slopes. Make sure the power liftgate is enabled. Make sure the transmission is in park (P), ensure nothing is obstructing the liftgate path and there is not excessive weight on the liftgate. If there are continued issues, the battery voltage may be low or there may be other system issues. See an authorized dealer.

Liftgate - Vehicles With: Manual Liftgate

OPENING THE LIFTGATE

OPENING THE LIFTGATE FROM OUTSIDE YOUR VEHICLE



Press the control button to unlatch the liftgate and then lift to open.

Note: Be careful when opening or closing the liftgate in a garage or other enclosed area to avoid damaging the liftgate.

Note: Do not hang anything, for example a bike rack, from the glass or liftgate. This could damage the liftgate and its components.

Note: Do not leave the liftgate open while driving. This could damage the liftgate and its components.

OPENING THE LIFTGATE USING THE REMOTE CONTROL



Press the button twice within three seconds. The liftgate unlocks for 45 seconds, during which time you can open the liftgate using the outside control button.

Note: Be careful when opening or closing the liftgate in a garage or other enclosed area to avoid damaging the liftgate.

Note: Do not hang anything, for example a bike rack, from the glass or liftgate. This could damage the liftgate and its components.

Note: Do not leave the liftgate open while driving. This could damage the liftgate and its components.

CLOSING THE LIFTGATE

CLOSING THE LIFTGATE FROM OUTSIDE YOUR VEHICLE



WARNING: It is extremely dangerous to ride in a cargo area, inside or outside of a vehicle. In a crash, people riding in these areas are more likely to be seriously injured or killed. Do not allow people to ride in any area of your vehicle that is not equipped with seats and seatbelts. Make sure everyone in your vehicle is in a seat and properly using a seatbelt. Failure to follow this warning could result in serious personal injury or death.

Liftgate - Vehicles With: Manual Liftgate



A handle is located inside the liftgate to help with closing.

Note: *Make sure that you fully close the liftgate to prevent cargo from falling out.*

Security

PASSIVE ANTI-THEFT SYSTEM

WHAT IS THE PASSIVE ANTI-THEFT SYSTEM

The passive anti-theft system prevents someone from starting the vehicle with an incorrectly coded key.

Note: *Do not leave a duplicate coded key in your vehicle. Always take the keys and lock all the doors when leaving your vehicle.*

HOW DOES THE PASSIVE ANTI-THEFT SYSTEM WORK

The passive anti-theft system arms when you switch the ignition off.

It disarms when the ignition is switched on with a correctly coded key.

Note: *The system is not compatible with non-Ford aftermarket remote start systems.*

Note: *Do not leave a duplicate coded key in your vehicle. Always take the keys and lock all doors when leaving your vehicle.*

ANTI-THEFT ALARM SYSTEM

WHAT IS THE ANTI-THEFT ALARM SYSTEM

The anti-theft alarm system warns you of an unauthorized entry to your vehicle.

HOW DOES THE ANTI-THEFT ALARM SYSTEM WORK

When armed, the anti-theft alarm is triggered in any of the following ways:

- If someone opens a door, the liftgate or the hood without a correctly coded key or remote control.
- If you turn the power on without a correctly coded key.
- If the interior sensors detect movement inside your vehicle.
- If the inclination sensors detect an attempt to raise your vehicle.
- If someone disconnects the vehicle battery or the battery backup alarm.

If the anti-theft alarm is triggered, the alarm horn sounds for 30 seconds and the direction indicators flash for 5 minutes.

Any further attempts to carry out one of the above sounds the alarm again.

WHAT IS THE PERIMETER ALARM

The perimeter alarm is designed to detect unauthorized access to your vehicle.

WHAT ARE THE INTERIOR SENSORS

The interior sensors detect movement inside your vehicle.

The interior sensors are in the overhead console.

Note: *Do not cover the interior sensors.*

Note: *If you set the cabin comfort level for your departure time with the alarm armed, the interior sensors deactivate for the duration of the cabin preconditioning to avoid a false alarm.*

Security

WHAT ARE THE INCLINATION SENSORS

The inclination sensor is designed to detect an attempt to raise your vehicle, for example to remove a wheel or to tow it away.

WHAT IS THE BATTERY BACKUP ALARM

The battery backup alarm is an additional alarm sounder that has its own battery. It can detect if the vehicle battery is disconnected to overcome the alarm system.

ARMING THE ANTI-THEFT ALARM SYSTEM

The alarm is ready to arm when your vehicle is switched off.

Lock your vehicle with your remote control to arm the alarm.

DISARMING THE ANTI-THEFT ALARM SYSTEM

Disarm the alarm by performing any of the following actions:

- Unlock the doors or luggage compartment with the remote control.
- Switch your vehicle on or start your vehicle.

ANTI-THEFT ALARM SYSTEM SETTINGS

WHAT ARE THE ALARM SECURITY LEVELS

You can select two levels of alarm security, all sensors and perimeter sensing.

All Sensors

All sensors is the standard setting.

In all sensors, all equipped sensors are on when you arm the alarm.

Note: Do not arm the alarm with all sensors if passengers, animals or other moving objects are inside your vehicle.

Perimeter Sensing

In perimeter sensing, the interior sensors are off when you arm the alarm.

All the other equipped sensors activate when you arm the alarm in this mode.

SETTING THE ALARM SECURITY LEVEL

1.  Press the button on the touchscreen.
2. Press **Vehicle**.
3. Press **Alarm System**.
4. Press **Motion sensors**.
5. Press a setting.

WHAT IS ASK ON EXIT

You can choose which level of security you require after you switch the ignition off.

Note: If you do not choose a setting, the system defaults to all sensors.

SWITCHING ASK ON EXIT ON AND OFF

1.  Press the button on the touchscreen.
2. Press **Vehicle**.
3. Press **Alarm System**.

Security

4. Press **Ask on exit**.

5. Press a setting.

SECURITY – TROUBLESHOOTING

SECURITY – INFORMATION MESSAGES

Message	Details
No key detected	The system has not detected a correctly coded key.
Starting system malfunction	The system has malfunctioned. Have your vehicle checked as soon as possible.
Vehicle alarm Start vehicle to stop alarm	Displays when the alarm has been triggered due to unauthorized entry.
Alarm announcement	

Security

SECURITY – FREQUENTLY ASKED QUESTIONS

What should I do if there is any potential alarm problem with my vehicle?

Take all remote controls to an authorized dealer if there is any potential alarm problem with your vehicle.

What should I do if the vehicle is unable to start with a correctly coded key?

Have your vehicle checked as soon as possible.

Steering Wheel

ADJUSTING THE STEERING WHEEL

[Adjusting the Steering Wheel](#)



WARNING: Do not adjust the steering wheel when your vehicle is moving.

Note: Make sure that you are sitting in the correct position.

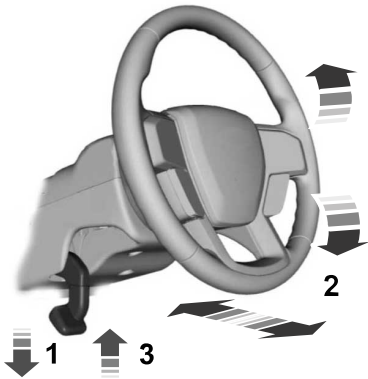

1. Unlock the steering column.
2. Adjust the steering wheel to the position you prefer.
3. Lock the steering column.

HORN



Press on the center of the steering wheel near the horn icon to activate the horn.

SWITCHING THE HEATED STEERING WHEEL ON AND OFF



To activate the heated steering wheel, press the button on the touchscreen near the climate controls. The button illuminates when the heated steering wheel is on. To turn it off, press the heated steering wheel button again.

Note: The engine must be running to use the heated steering wheel.

Note: A sensor regulates the temperature of the steering wheel.

Note: Depending on the remote start settings, the heated steering wheel may remain on after remote starting your vehicle. It may also turn on when you start your vehicle if it was on the last time the engine was switched off.

Wipers and Washers

WIPERS

WIPER PRECAUTIONS

Do not operate the wipers on a dry windshield. This could scratch the glass or damage the wiper blades. Use the windshield washers before wiping a dry windshield.

Fully defrost the windshield before you switch the windshield wipers on.

Switch the windshield wipers off before entering a car wash.

SWITCHING WINDSHIELD WIPERS ON AND OFF

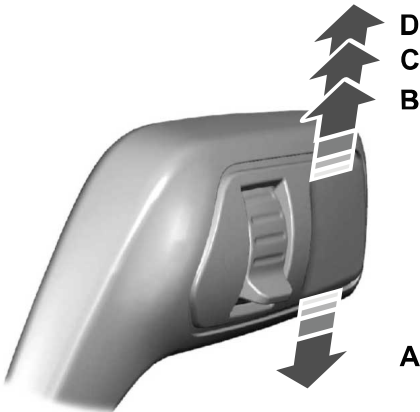

- A Single wipe.
- B Intermittent wipe/Auto wipe.
- C Normal wipe.
- D High-speed wipe.



Push the lever up or down to operate the windshield wipers.

AUTOWIPERS

WHAT ARE AUTOWIPERS

Autowipers turns on and controls the speed and frequency of the windshield wipers.

AUTOWIPERS SETTINGS

1.  Press the button on the touchscreen.
2. Press **Vehicle**.
3. Press **Wipers**.
4. Switch **Rain sensing** on or off.

Note: When you switch the feature off, the wipers do not operate based on the rain sensor. When you switch on the windshield wipers to the intermittent wipe position with the feature off, the wipers use the wipe speed set by the rotary control.

Wipers and Washers

ADJUSTING THE SENSITIVITY OF THE RAIN SENSOR

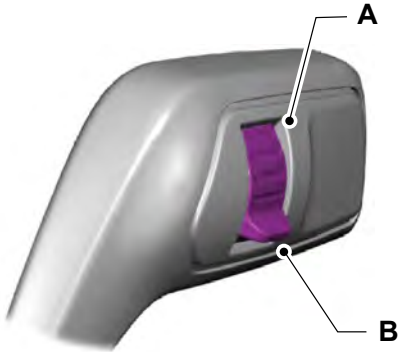

- A High sensitivity.
- B Low sensitivity.

Use the rotary control to set the rain sensor sensitivity.

When you select high sensitivity, the wipers operate when the sensor detects a small amount of water on the windshield.

When you select low sensitivity, the wipers operate when the sensor detects a large amount of water on the windshield.

SWITCHING THE REAR WINDOW WIPER ON AND OFF

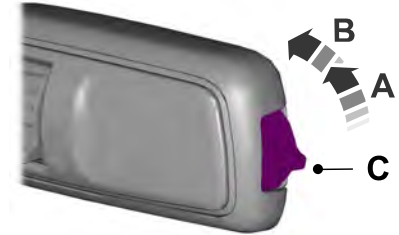

- A Intermittent wipe.
- B Continuous wipe.
- C Rear window wiper off.

REVERSE WIPE

WHAT IS REVERSE WIPE

Reverse wipe turns on the rear window wiper when you shift into reverse (R) and the windshield wipers are on.

REVERSE WIPE SETTINGS

1.  Press the button on the touchscreen.
2. Press **Vehicle**.
3. Press **Wipers**.
4. Switch **Reverse wiper** on or off.

Wipers and Washers

CHECKING THE WIPER BLADES



Run the tip of your fingers over the edge of the blade to check for roughness.

REPLACING THE FRONT WIPER BLADES

Make sure your vehicle is off before beginning this procedure.

Note: Do not manually move the wiper arms. To place the wiper arms in a service position, switch your vehicle on in accessory mode, switch on the wipers and switch your vehicle off when the wipers are at their highest position.

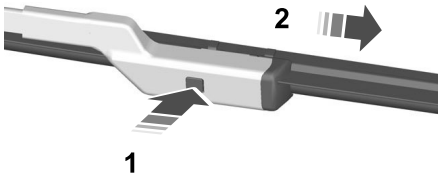

1. Lift the wiper arm and then press the wiper blade locking button.

Note: Do not hold the wiper blade to lift the wiper arm.

2. Remove the wiper blade.

Note: Make sure that the wiper arm does not spring back against the glass when the wiper blade is not attached.

3. To install, reverse the removal procedure.

Note: Make sure that the wiper blade locks into place.

REPLACING THE REAR WIPER BLADES

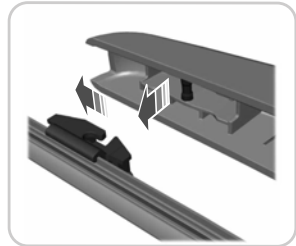
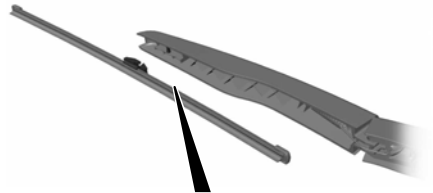

1. Lift the wiper arm.

Note: Do not hold the wiper blade to lift the wiper arm.

2. Remove the wiper blade.

Note: Make sure that the wiper arm does not spring back against the glass when the wiper blade is not attached.

3. To install, reverse the removal procedure.

Note: Make sure that the wiper blade locks into place.

Wipers and Washers

WASHERS

WASHER PRECAUTIONS



WARNING: If you operate your vehicle in temperatures below 5°C (41°F), use washer fluid with antifreeze protection. Failure to use washer fluid with antifreeze protection in cold weather could result in impaired windshield vision and increase the risk of injury or accident.

Do not operate the washers when the washer reservoir is empty. This could cause the washer pump to overheat.

Keep the outside of the windshield clean. The rain sensor is very sensitive and the wipers may operate if dirt, mist or insects hit the windshield.

USING THE WINDSHIELD WASHER



Pull the lever toward you to operate the windshield washer.

Note: A courtesy wipe occurs a short time after the wipers stop to clear any remaining washer fluid when switched on. See **Switching the Courtesy Wipe On and Off** (page 102).

SWITCHING THE COURTESY WIPE ON AND OFF

Courtesy Wipe

1.  Press the button on the touchscreen.
2. Press **Vehicle**.
3. Press **Wipers**.
4. Switch **Courtesy Wipe** on or off.

USING THE REAR WINDOW WASHER



Push the lever away from you to operate the rear window washer.

Note: A courtesy wipe occurs a short time after the wipers stop to clear any remaining washer fluid when switched on. See **Switching the Courtesy Wipe On and Off** (page 102).

Wipers and Washers

ADDING WASHER FLUID

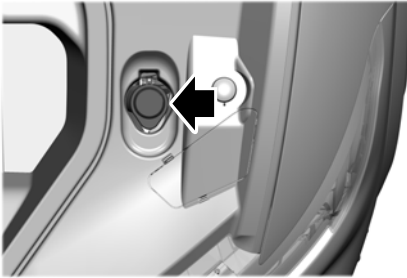

WASHER FLUID SPECIFICATION

See **Washer Fluid Specification** (page 361).

WIPERS AND WASHERS – TROUBLESHOOTING

WIPERS AND WASHERS – WARNING LAMPS



Illuminates when the windshield washer fluid is low.

WIPERS AND WASHERS – FREQUENTLY ASKED QUESTIONS

Why are there streaks and smears on the windshield?

- The wiper blades could be dirty, worn or damaged. Check the wiper blades. See **Checking the Wiper Blades** (page 101). If the wiper blades are dirty, clean them with washer fluid or water applied with a soft sponge or cloth. If the wiper blades are worn or damaged, install new ones. See **Replacing the Front Wiper Blades** (page 101).

Exterior Lighting

EXTERIOR LIGHTING CONTROL

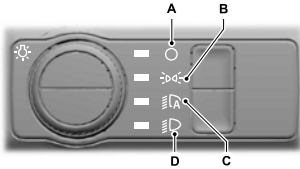

- A Lamps off.
- B Parking lamps on.
- C Autolamps on.
- D Headlamps on.

Rotate the control to make a selection.

Note: The lighting control defaults to autolamps every time you switch your vehicle on.

HEADLAMPS

USING THE HIGH BEAM HEADLAMPS



Push the lever away from you to switch the high beams on.

Push the lever forward again or pull the lever toward you to switch the high beams off.

Slightly pull the lever toward you and release it to flash the headlamps.

Note: Continuous activation only with headlamps on.

SWITCHING HEADLAMP EXIT DELAY ON AND OFF

To switch headlamp exit delay on, pull the turn signal lever toward you after switching your vehicle off.

To switch headlamp exit delay off, pull the turn signal lever toward you again or switch your vehicle on.

Note: The headlamps turn off after three minutes with any door open or 30 seconds after the last door closes.

ADJUSTING THE LEVEL OF THE HEADLAMPS

Your vehicle has a dynamic leveling system. The headlamps do not require additional aim adjustment.

HEADLAMP INDICATORS

Lamps On



Illuminates when you switch the low beam headlamps or the parking lamps on.

Headlamp High Beam



Illuminates when you switch the high beam headlamps on.

Exterior Lighting

HEADLAMPS – TROUBLESHOOTING

HEADLAMPS – FREQUENTLY ASKED QUESTIONS

Why is there condensation in the headlamps?

- Headlamps have vents to accommodate normal changes in air pressure. Condensation can be a natural by-product of this design. When moist air enters the lamp assembly through the vents, there is a possibility that condensation can occur when the temperature is cold. When normal condensation occurs, a fine mist can form on the interior of the lens. The fine mist eventually clears and exits through the vents during normal operation.

How much condensation is acceptable?

- The presence of a fine mist, for example no streaks, drip marks or large droplets. A fine mist covers less than 50% of the lens.

How long may it take for the acceptable condensation to be cleared?

- Clearing time may take as long as 48 hours under dry weather conditions.

How much condensation is unacceptable?

- A water puddle inside the lamp. Streaks, drip marks or large droplets present on the interior of the lens.

What should I do if unacceptable condensation is present?

- Have your vehicle checked as soon as possible.

Why do my headlamps turn off when I have them switched on when I switch my vehicle off?

- The battery saver turns the headlamps off after a short period of time after you switch your vehicle off.

AUTOLAMPS

WHAT ARE AUTOLAMPS

 **WARNING:** The system does not relieve you of your responsibility to drive with due care and attention. You may need to override the system if it does not turn the headlamps on in low visibility conditions, for example daytime fog.

Autolamps turn the headlamps on in low light situations or when the windshield wipers operate.

AUTOLAMP SETTINGS

To set the amount of time that the headlamps remain on after you switch your vehicle off:

1.  Press the button on the touchscreen.
2. Press **Vehicle**.
3. Press **Lighting**.
4. Press **Headlamp delay**.
5. Press a setting.

Exterior Lighting

EXTERIOR LAMPS

USING THE TURN SIGNAL LAMPS



Push the lever up or down to switch the turn signal lamps on.

Set the lever to the middle position to switch the turn signal lamps off.

Note: Tap the lever up or down to make the turn signal lamps flash three times.

Turn Signal Lamp Indicator



It flashes when you switch the turn signal lamps on.

Note: An increase in the rate of flashing warns of a failed turn signal lamp.

SWITCHING THE DAYTIME RUNNING LAMPS ON AND OFF



WARNING: The daytime running lamps system does not activate the rear lamps and may not provide adequate lighting during low visibility driving conditions. Make sure you switch the headlamps on, as appropriate, during all low visibility conditions. Failure to do so may result in a crash.

Daytime running lamps are always on unless you switch on the headlamps.

USING THE REAR FOG LAMPS

To switch the lamps on or off:

1. Set the lighting control to the headlamps or autolamps position.

Note: When the lighting control is in the autolamps position, you cannot switch the rear fog lamps on unless the low beam headlamps are on.

- 2.



Press the button on the lighting control to switch the rear fog lamps on or off.

Note: Only switch the rear fog lamps on during reduced visibility.

Rear Fog Lamp Indicator



It illuminates when you switch the rear fog lamps on.

SWITCHING WELCOME LIGHTING ON AND OFF

[Experiencing Mustang Mach-E Welcome Lighting Video Link](#)

Welcome lighting slowly turns on the exterior lamps when you approach your vehicle with an authenticated device or unlock the doors.

- 1.



Press the button on the touchscreen.

2. Press **Vehicle**.
3. Press **Lighting**.
4. Switch **Welcome lighting** on or off.

Exterior Lighting

EXTERIOR LAMP INDICATORS

Rear Fog Lamp



It illuminates when you switch the rear fog lamps on.

Turn Signal Lamp



It flashes when you switch the turn signal lamps on.

Note: An increase in the rate of flashing warns of a failed turn signal lamp.

EXTERIOR LAMPS ON AUDIBLE WARNING

Sounds when you open the driver door and the exterior lamps are on.

AUTOMATIC HIGH BEAM CONTROL

HOW DOES AUTOMATIC HIGH BEAM CONTROL WORK

Automatic high beam control turns the high beams on if it is dark enough and no other traffic is present. If it detects an approaching vehicle's headlamps or tail lamps, or street lighting ahead, the system turns the high beams off.

A camera sensor, centrally mounted behind the windshield of your vehicle, continuously monitors conditions to turn the high beams on and off.

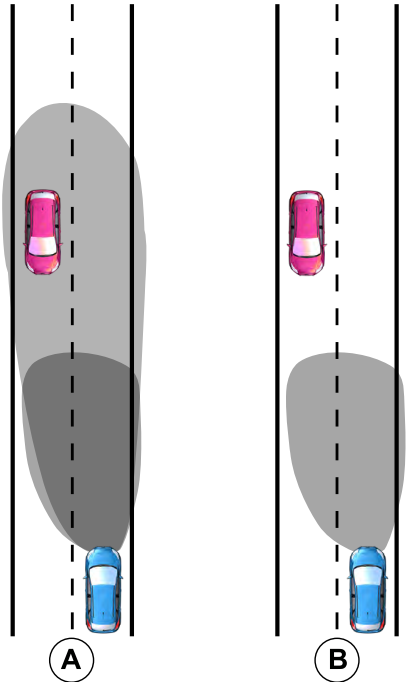

- A Without automatic high beam control.
- B With automatic high beam control.

AUTOMATIC HIGH BEAM CONTROL PRECAUTIONS



WARNING: The system does not relieve you of your responsibility to drive with due care and attention. You may need to override the system if it does not turn the high beams on or off.

Exterior Lighting



WARNING: The system may not switch the high beams off if the lights of oncoming vehicles are hidden by obstacles, for example guard rails.



WARNING: Do not use the system in poor visibility, for example fog, heavy rain, spray or snow.



WARNING: You may need to override the system when approaching other road users.



WARNING: You may need to override the system during inclement weather.

AUTOMATIC HIGH BEAM CONTROL REQUIREMENTS

The system turns the high beams on if all of the following occur:

- You switch the system on.
- You set the lighting control to the autolamps position.
- The ambient light level is low enough that you require high beams.
- There is no traffic in front of your vehicle.
- The vehicle speed is greater than approximately 40 km/h (25 mph).

AUTOMATIC HIGH BEAM CONTROL LIMITATIONS

The system turns the high beams off if any of the following occur:

- You switch the system off.
- You set the lighting control to any position except autolamps.
- The ambient light level is high enough that you do not require high beams.

- The system detects an approaching vehicle's headlamps or a leading vehicle's tail lamps.
- The system detects severe rain, snow or fog.
- The system detects street lighting.
- The camera has reduced visibility.
- The vehicle speed falls below approximately 30 km/h (19 mph).

SWITCHING AUTOMATIC HIGH BEAM CONTROL ON AND OFF

1.  Press the button on the touchscreen.
2. Press **Vehicle**.
3. Press **Lighting**.
4. Switch **Auto highbeam** on or off.

AUTOMATIC HIGH BEAM CONTROL INDICATORS



Illuminates to confirm when the system is ready to assist.

OVERRIDING AUTOMATIC HIGH BEAM CONTROL



Exterior Lighting

Push the lever away from you to switch the high beams on.

Push the lever away from you again to switch the high beams off.

Push the lever away from you for a third time to switch automatic high beam control back on.

AUTOMATIC HIGH BEAM CONTROL – TROUBLESHOOTING

AUTOMATIC HIGH BEAM CONTROL – INFORMATION MESSAGES

Message	Description
Front camera Low visibility Clean screen	The camera has reduced visibility. Clean the windshield. If the message continues to appear, have your vehicle checked as soon as possible.
Front camera temporarily not available	The camera has malfunctioned. Wait a short period of time for the camera to cool down. If the message continues to appear, have your vehicle checked as soon as possible.
Front camera malfunction Service required	The camera has malfunctioned. Have your vehicle checked as soon as possible.

GLARE FREE LIGHTING (IF EQUIPPED)

HOW DOES GLARE FREE LIGHTING WORK

Glare free lighting enhances visibility and minimizes glare for other road users.

Exterior Lighting

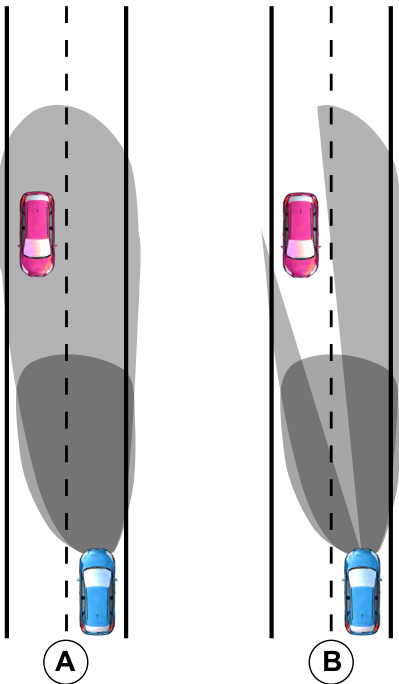

- A Without glare free lighting.
B With glare free lighting.

GLARE FREE LIGHTING PRECAUTIONS

WARNING: The system does not relieve you of your responsibility to drive with due care and attention. You may need to override the system if it does not adapt the light.

- WARNING:** The system may not adapt the lighting to avoid glare if the lights of oncoming vehicles are hidden by obstacles such as guard rails.
- WARNING:** You may need to override the system when approaching other road users.
- WARNING:** You may need to override the system during inclement weather.
- WARNING:** Do not use the system in poor visibility, for example fog, heavy rain, spray or snow.

GLARE FREE LIGHTING REQUIREMENTS

The system turns on if all of the following occur:

- You switch the system on.
- You set the lighting control to the autolamps position.
- The ambient light level is low enough.
- Your vehicle speed is greater than approximately 40 km/h (25 mph).

The system adapts the lighting to avoid glare if all of the following occur:

- You switch the system on.
- You set the lighting control to the autolamps position.
- The system detects an approaching vehicle's headlamps or rear lamps.

Exterior Lighting

GLARE FREE LIGHTING LIMITATIONS

The system turns off if any of the following occur:

- You switch the system off.
- You set the lighting control to any position except autolamps.
- The ambient light level is high enough.
- The system detects severe rain, snow or fog.
- The system detects street lighting.
- The camera has reduced visibility.
- The vehicle speed falls below approximately 30 km/h (19 mph).

Note: *The deactivation speed is lower on curves.*

SWITCHING GLARE FREE LIGHTING ON AND OFF

1.  Press the button on the touchscreen.
2. Press **Vehicle**.
3. Press **Lighting**.
4. Switch **Glarefree Lighting** on or off.

GLARE FREE LIGHTING INDICATORS



Illuminates to confirm when the system is ready to assist.

OVERRIDING GLARE FREE LIGHTING



Push the lever away from you to switch the high beams on.

Push the lever away from you again to switch the high beams off.

Push the lever away from you for a third time to switch glare free lighting back on.

Exterior Lighting

GLARE FREE LIGHTING – TROUBLESHOOTING (IF EQUIPPED)

GLARE FREE LIGHTING – INFORMATION MESSAGES

Message	Description
Front camera Low visibility Clean screen	The camera has reduced visibility. Clean the windshield. If the message continues to appear, have your vehicle checked as soon as possible.
Front camera temporarily not available	The camera has malfunctioned. Wait a short period of time for the camera to cool down. If the message continues to appear, have your vehicle checked as soon as possible.
Front camera malfunction Service required	The camera has malfunctioned. Have your vehicle checked as soon as possible.

ADAPTIVE FRONT LIGHTING

HOW DOES ADAPTIVE FRONT LIGHTING WORK

Adaptive front lighting provides additional light on the road depending on your vehicle speed and steering wheel input.

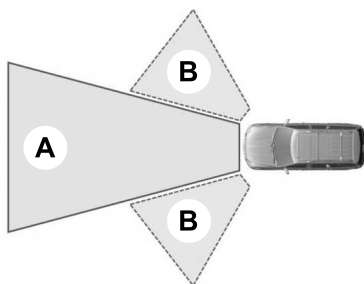

- A Standard low beam.
- B Additional lighting.

SWITCHING ADAPTIVE FRONT LIGHTING ON AND OFF

1.  Press the button on the touchscreen.
2. Press **Vehicle**.
3. Press **Lighting**.
4. Switch **Adaptive headlamps** on or off.

Set the lighting control to the autolamps position to use the adaptive front lighting.

SWITCHING THE HEADLAMPS FOR DRIVING ON THE LEFT OR RIGHT-HAND SIDE OF THE ROAD

1.  Press the button on the touchscreen.
2. Press **Vehicle**.
3. Press **Lighting**.
4. Press **Adaptive headlamp setup**.
5. Press a setting.

Interior Lighting

SWITCHING ALL OF THE INTERIOR LAMPS ON AND OFF

The lamps turn on under the following conditions:

- You open any door.
- You press a button on the remote control.
- You press the all lamps on button on the overhead console.



Press to switch all interior lamps on or off.

SWITCHING THE FRONT INTERIOR LAMPS ON AND OFF



The front interior lamp switches are on the overhead console.

Note: The position of each button on the overhead console depends on your vehicle.

Individual Map Lamps



Press to switch the left-hand individual dome lamp on and off.



Press to switch the right-hand individual dome lamp on and off.

SWITCHING THE REAR INTERIOR LAMPS ON AND OFF



The rear interior lamps may be above the rear seat or above the rear windows.



Press to switch the lamps on or off.

Note: If you switch the rear lamps on through the overhead console, you cannot switch them off with the rear lamp switch.

INTERIOR LAMP FUNCTION

WHAT IS THE INTERIOR LAMP FUNCTION

The interior lamp function switches the courtesy and door lamps on or off.

SWITCHING THE INTERIOR LAMP FUNCTION ON AND OFF



Press to switch the interior lamp function on and off.

Note: The indicator lamp illuminates amber when the door function is off.

Interior Lighting

ADJUSTING THE INSTRUMENT PANEL LIGHTING BRIGHTNESS

The instrument lighting dimmer buttons are on the lighting control.



Repeatedly press one of the buttons to adjust the brightness.



AMBIENT LIGHTING (IF EQUIPPED)

SWITCHING AMBIENT LIGHTING ON AND OFF

1.  Press the button on the touchscreen.
2. Press **General**.
3. Press **Ambient Light**.
4. Press a color.

ADJUSTING AMBIENT LIGHTING

Drag the selected color up or down.

INTERIOR LIGHTING – TROUBLESHOOTING

INTERIOR LIGHTING – FREQUENTLY ASKED QUESTIONS

Why do my courtesy lamps or interior lamps turn off when I have them switched on when I switch my vehicle off?

The battery saver turns the courtesy lamps and interior lamps off after a short period of time after you switch your vehicle off.

Windows

OPENING AND CLOSING THE WINDOWS



WARNING: Do not leave children unattended in your vehicle and do not let them play with the power windows. Failure to follow this instruction could result in personal injury.



WARNING: When closing the power windows, verify they are free of obstruction and make sure that children and pets are not in the proximity of the window openings.



Press the window control switch to open the window. Lift the window control switch to close the window.

Note: The power windows operate with the ignition on, and for several minutes after you switch the ignition off or until you open a front door.

To reduce wind noise or pulsing noise when one window is open, slightly open the opposite window.

One-Touch Open

Fully press the window control switch and release it. Press again or lift it to stop the window.

One-Touch Close

Fully lift the window control switch and release it. Press again or lift it to stop the window.

Resetting One-Touch Close

Carry out all steps within 30 seconds of starting the sequence.

1. Close the window.

2. Press and hold the window control switch until the window is fully open. Keep the window control switch pressed for a few seconds.
3. Lift and hold the window control switch until the window is fully closed. Keep the window control switch held for a few seconds.
4. Press and hold the window control switch until the window is fully open. Keep the window control switch pressed for a few seconds.
5. Lift and hold the window control switch until the window is fully closed. Keep the window control switch held for a few seconds.

Note: Repeat the procedure if the window does not close when you use one-touch.

GLOBAL OPENING AND CLOSING

WHAT IS GLOBAL OPENING AND CLOSING

You can use the remote control to open the windows with the ignition off.

USING GLOBAL OPENING

1. Press and release the unlock button on the remote control.
2. Press and hold the unlock button on the remote control.
3. Release the button when the windows start to open.

Press the lock or the unlock button on the remote control to stop global opening.

Note: You can use global opening for a short period of time when you unlock your vehicle using the remote control.

Windows

SWITCHING GLOBAL OPENING ON AND OFF

1.  Press the button on the touchscreen.
2. Press **Vehicle**.
3. Press **Windows**.
4. Switch **Global open** on or off.

USING GLOBAL CLOSING



WARNING: When closing the power windows, verify they are free of obstruction and make sure that children and pets are not in the proximity of the window openings.

1. Press and hold the lock button on the remote control.
2. Release the button when the windows start to close.

Press the lock or the unlock button on the remote control to stop global closing.

Note: *Bounce-back is on during global closing. See **What Is Window Bounce-Back** (page 116).*

SWITCHING GLOBAL CLOSING ON AND OFF

1.  Press the button on the touchscreen.
2. Press **Vehicle**.
3. Press **Windows**.
4. Switch **Global close** on or off.

WINDOW BOUNCE-BACK

WHAT IS WINDOW BOUNCE-BACK

The window stops and reverses if it detects an obstruction when closing.

OVERRIDING WINDOW BOUNCE-BACK



WARNING: If you override bounce-back, the window does not reverse if it detects an obstacle. Take care when closing the windows to avoid personal injury or damage to your vehicle.

1. Close the window until it reaches the point of resistance and let it reverse.
2. Lift and hold the window control switch within two seconds to override bounce-back and close the window. Bounce-back is now disabled and you can close the window manually.

Note: *The window goes past the point of resistance and you can fully close it.*

Note: *If the window does not close, have your vehicle checked as soon as possible.*

LOCKING THE REAR WINDOW CONTROLS

When the rear window lock/child safety lock switch is engaged, the window switches mounted on the rear door panels are deactivated.

Windows



The control is on the driver door. It enables both the rear window locks and the child safety locks.

Press the control to switch the rear window locks and child safety locks on. Press the control again to switch them off. A light on the control illuminates when you switch them on.

The rear window lock and child lock settings remain active when you switch off your vehicle.

Interior Mirror

INTERIOR MIRROR PRECAUTIONS



WARNING: Do not adjust the mirrors when your vehicle is moving. This could result in the loss of control of your vehicle, serious personal injury or death.

Note: Do not clean the mirror housing or glass with harsh abrasives, fuel or other petroleum-based cleaning products.

AUTO-DIMMING INTERIOR MIRROR

WHAT IS THE AUTO-DIMMING INTERIOR MIRROR

The mirror dims to reduce the effect of bright light from behind. It returns to normal when the bright light from behind is no longer present or if you shift into reverse (R).

AUTO-DIMMING INTERIOR MIRROR LIMITATIONS

Do not block the sensors on the front and back of the mirror.

Note: A rear center passenger or raised rear center head restraint could prevent light from reaching the sensor.

Exterior Mirrors

ADJUSTING THE EXTERIOR MIRRORS



WARNING: Do not adjust the mirrors when your vehicle is moving. This could result in the loss of control of your vehicle, serious personal injury or death.

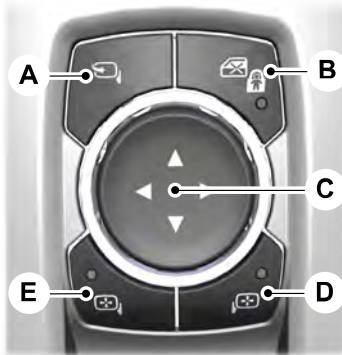

- A Power fold.
- B Window and child safety lock.
- C Adjustment control.
- D Right-hand mirror.
- E Left-hand mirror.

To adjust the mirrors, switch your vehicle on, with the push button start in accessory mode or your vehicle running.

1. Select the mirror you want to adjust. The control light turns on.
2. Use the adjustment control to adjust the position of the mirror.
3. Press the mirror control again. The control light turns off.

FOLDING THE EXTERIOR MIRRORS - VEHICLES WITH: POWER FOLDING MIRRORS

Power-Folding Mirrors (If Equipped)

To fold both mirrors, switch your vehicle on, with the push button start in accessory mode or your vehicle running.



For tight parking conditions, press the control switch to fold the mirrors.

Press the control switch again to unfold the mirrors.

Note: Do not stop the mirrors midway through their movement. Wait until the mirrors stop moving and press the control again.

Note: The left-hand and right-hand mirrors move at different rates. For example, one mirror may stop when the other one continues to move. This is normal. Moving the mirrors 10 or more times within one minute, or repeated folding and unfolding of the mirrors when holding the control down during full travel, may disable the system to protect the motors from overheating. Wait approximately three minutes with your vehicle running, and up to 10 minutes with your vehicle off, for the system to reset and operate as normal.

Loose Mirror

If the power-folding mirrors are manually folded, they may not properly work even after you re-position them. You need to reset them if:

- The mirrors vibrate when you drive.
- The mirrors feel loose.
- The mirrors do not stay in the folded or unfolded position.
- One of the mirrors is not in its normal driving position.

Exterior Mirrors

To reset the power-fold feature, use the power-folding mirror control to fold and unfold the mirrors. A loud noise could occur when you reset the power-folding mirrors, this sound is normal. Repeat this process as needed each time the mirrors are manually folded.

FOLDING THE EXTERIOR MIRRORS - VEHICLES WITH: MANUAL FOLDING MIRRORS

Push the mirror toward the door window glass. Make sure that you fully engage the mirror in its support when returning it to its original position.

Heated Exterior Mirrors

See **Switching the Heated Mirrors On and Off** (page 134).

Memory Mirrors

You can save and recall the mirror positions through the memory function. See **Saving a Preset Position** (page 150).

Directional Indicator Mirrors

When your vehicle is running, the forward-facing portion of the appropriate mirror housing blinks when you switch on the turn signal.

Puddle Lamps

The puddle lamps turn on when you approach your vehicle with a remote control or phone. If your vehicle has auto-folding mirrors, the puddle lamps are only on if the mirrors are unfolded and turn off when the mirrors fold.

360 Degree Camera (If Equipped)

See **Locating the 360 Degree Cameras** (page 227).

Blind Spot Information System

See **What Is Blind Spot Information System** (page 272).

Instrument Cluster

INSTRUMENT CLUSTER OVERVIEW - EXCLUDING: GT

Note: The instrument cluster display can be customized to display information in several different layouts. Maximum zone complexity shown.

Note: The instrument cluster display changes based on feature settings selected in the center display screen or set with steering wheel controls.

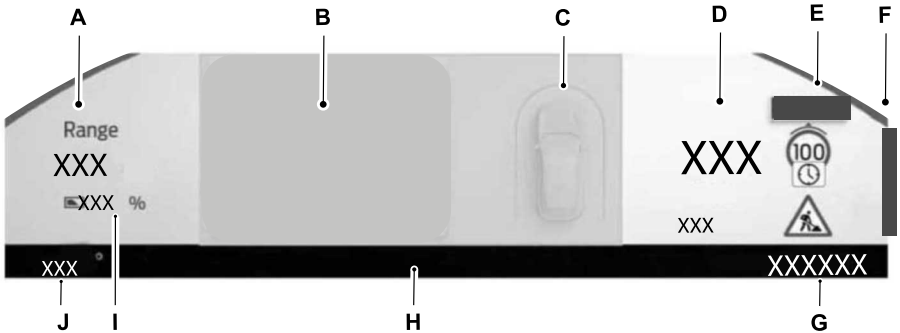

- A Range display area.
- B Pop-up message display area.
- C Driver assist area.
- D Vehicle speed display area.
- E Driver assist message display area.
- F Gear indicator.
- G Odometer.
- H Information bar.
- I High voltage battery gauge.
- J Compass or ambient temperature.

Instrument Cluster

INSTRUMENT CLUSTER OVERVIEW - GT

Note: The instrument cluster display can be customized to display information in several different layouts. Maximum zone complexity shown.

Note: The instrument cluster display changes based on feature settings selected in the center display screen or set with steering wheel controls.

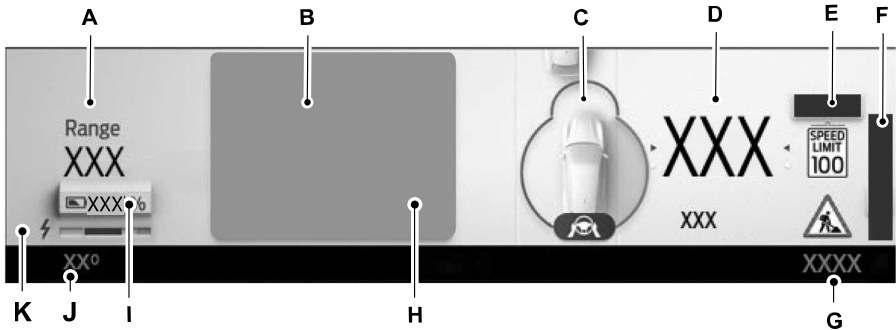

- A Range display area.
- B Pop-up message display area.
- C Driver assist area.
- D Vehicle speed display area.
- E Driver assist message display area.
- F Gear indicator.
- G Odometer.
- H Information bar.
- I High voltage battery gauge.
- J Compass or ambient temperature.
- K Power gauge.

Instrument Cluster

POWER GAUGE - GT

The power gauge displays the amount of power going to the wheels when accelerating or maintaining speed. When the system limits the available maximum power, the right side of the gauge shows gray lines representing the proportional reduction in available power. When slowing down by lifting your foot off the accelerator pedal or pressing the brake, the gauge displays the amount of power the regenerative system captures and returns to the high voltage battery.

SPEEDOMETER

Indicates the vehicle speed.

VEHICLE RANGE DISPLAY

Displays the approximate range your vehicle can travel on the battery's current state of charge. Estimates vary based on the energy used when driving and the energy available in the high voltage battery.

The amount of energy being used when driving is affected by:

- Mild or aggressive acceleration or braking.
- Your vehicle's speed.
- Use of accessories, such as climate control.
- Ambient temperature and weather conditions.
- Driving in a city or on a highway.
- Driving on flat or hilly roads.
- Towing.

The available energy capacity in the high voltage battery is affected by cold temperatures and battery degradation.

See **Preserving Your High Voltage Battery** (page 158).

When your navigation system has an active route the distance to your destination or next charging station is displayed.

Note: *It is normal for the vehicle range estimates to vary due to changes in average energy usage and battery temperature. This could cause different range estimates each time you fully charge your battery. See **Maximizing Your Driving Range** (page 308).*

Note: *When you leave your vehicle unplugged, it periodically uses energy from the high voltage battery to recharge the 12-volt accessory battery, resulting in a reduced driving range.*

HIGH VOLTAGE BATTERY GAUGE

Displays the high voltage battery state of charge in the form of a gauge or a percentage. A full fill or 100% charge represents the total amount of energy you can get from plugging your vehicle in.

The gauge is normally blue. When a low battery condition is reached the gauge is amber. When the battery is depleted the gauge is red.

When the full battery gauge is displayed and your navigation system has an active route, a symbol is added that represents the battery charge level needed to reach your destination or next charging station.

Charging Status

Additional charge information displays when you power on your vehicle without pressing the brake pedal and your vehicle is plugged in. Charging status includes the charge start or charge end time as appropriate. When DC charging, the time

Instrument Cluster

at 80% displays followed by the time at 100%. You can modify your vehicle charge settings on the information and entertainment display. See **Setting the Charging Schedule and Preferences** (page 180).

Charge Required to Reach Destination

When the navigation system has an active route, the instrument cluster displays the charge level required in order to reach your destination and the time when that charge level is available.

WHAT ARE THE INSTRUMENT CLUSTER WARNING LAMPS

Warning lamps alert you to a vehicle condition that could become serious. Some lamps illuminate when you start your vehicle to make sure they work. If any lamps remain on after starting your vehicle, refer to the respective system warning lamp for further information.

INSTRUMENT CLUSTER WARNING LAMPS

12V Battery



Illuminates when your vehicle is first switched on to show it is properly functioning.

If it illuminates when the motor is running, this indicates your vehicle requires service. Have your vehicle checked as soon as possible.

Driving when this warning lamp is on drains the 12V battery. If you must drive with this light on, turn off all accessories.

Anti-Lock Brake System



If it illuminates when you are driving, this indicates the system requires service. Your vehicle continues to have normal braking without the anti-lock brake system function. Have your vehicle checked as soon as possible.

Brake System



Illuminates when you apply the parking brake and your vehicle is on. If it illuminates when your vehicle is moving, make sure the parking brake is released. If the parking brake is released, this indicates low brake fluid level or the brake system requires service. Have your vehicle checked as soon as possible.

Note: Lamps may vary depending on region.

Door Ajar



Illuminates when your vehicle is on and any door is open.

Electric Parking Brake



Illuminates or flashes yellow when the electric parking brake requires service.



Electric Motor Coolant Temperature



If it illuminates, safely stop your vehicle and switch your vehicle off.

Fasten Seatbelt



Illuminates and a tone sounds until you fasten the seatbelts.

Instrument Cluster

High Voltage Battery



Illuminates blue under normal conditions. If it illuminates amber, the battery is low on charge. If it illuminates red, the battery is depleted.

Hood Ajar



Illuminates when your vehicle is on and the hood is not completely closed.

Icy Road Conditions



WARNING: Even if the temperature rises to above 4°C (39°F) there is no guarantee that the road is free of hazards caused by inclement weather.



Illuminates when the outside air temperature falls below 4°C (39°F).

Liftgate Ajar



Illuminates when your vehicle is on and the rear luggage compartment is not completely closed.

Limited Performance



Illuminates if your vehicle has limited performance due to a cold or hot battery. Drive with caution. Keep your vehicle connected to a charging system when not in use to maintain battery temperature.

Low Tire Pressure



Illuminates when your tire pressure is low. If illuminated, check your tire pressure as soon as possible. If it begins to flash at any time, have the system checked as soon as possible.

Low Washer Fluid Level



Illuminates when the washer fluid is low.

Powertrain Malfunction



Illuminates when the powertrain requires service. Have the system checked as soon as possible.

Stop Safely



Illuminates if an electrical component requires service or a failure that causes your vehicle to shut down or enter into a limited operating mode.

Vehicle Plugged In



Illuminates when your vehicle is plugged in.

WHAT ARE THE INSTRUMENT CLUSTER INDICATORS

Indicators notify you of various features that are active on your vehicle.

Instrument Cluster

INSTRUMENT CLUSTER INDICATORS

Adaptive Cruise Control



See **Adaptive Cruise Control** (page 234).

Automatic High Beam



See **Automatic High Beam Control Indicators** (page 108).

Auto Hold Active



See **Auto Hold** (page 209).

Auto Hold Unavailable



See **Auto Hold** (page 209).

Blind Spot Information System



See **Blind Spot Information System** (page 272).

BlueCruise



See **BlueCruise** (page 249).

Cruise Control



See **Adaptive Cruise Control** (page 234).

Headlamp High Beam



See **Using the High Beam Headlamps** (page 104).

Parking Lamps



See **Headlamp Indicators** (page 104).

Pre-Collision Assist



See **Pre-Collision Assist** (page 278).

Ready to Drive



See **Starting and Powering Off** (page 156).

Stability Control and Traction Control



See **Traction Control** (page 211). See **Stability Control** (page 213).



Turn Signal Lamps



See **Using the Turn Signal Lamps** (page 106).

Instrument Cluster Display

BRAKE COACH

The brake coach appears after the vehicle has come to a stop. It coaches you to brake in a manner that maximizes the amount of energy returned through the regenerative braking system.

The percent displayed indicates the regenerative braking efficiency, with 100% representing the maximum amount of energy recovery.

Note: *While regenerative braking works in all drive modes, brake coach display may not be available in all drive modes.*

You can switch brake coach on or off in the settings menu on your touchscreen.

1.  Press the button on the touchscreen.
2. Press **Vehicle**.
3. Switch **Brake Coach** on or off.

Personalized Settings

CHANGING THE LANGUAGE

1.  Press the button on the touchscreen.
2. Press **General**.
3. Press **Language**.
4. Select a language.

4. Select a pressure unit.

CHANGING THE MEASUREMENT UNIT

1.  Press the button on the touchscreen.
2. Press **General**.
3. Press **Measurement Unit**.
4. Select a measurement unit.

CHANGING THE TEMPERATURE UNIT

1.  Press the button on the touchscreen.
2. Press **General**.
3. Press **Temperature Unit**.
4. Select a temperature unit.

CHANGING THE TIRE PRESSURE UNIT

1.  Press the button on the touchscreen.
2. Press **General**.
3. Press **Tyre Pressure Unit**.

Trip Computer

ACCESSING THE TRIP COMPUTER

1.  Press the button on the touchscreen to open the application drawer.
2. Press **Trips**.

RESETTING THE TRIP COMPUTER

1.  Press the button on the touchscreen to open the application drawer.
2. Press **Trips**.
3. Press **Trip 1** or **Trip 2**.
4. Press **Reset**.

Note: *The current trip resets every time you start your vehicle.*

TRIP DATA

Trip data includes distance, time and energy economy. Better energy economy, meaning greater efficiency or lower consumption, results in increased driving range.

Where Did My Energy Go

Displays a breakdown of energy consumption for your trip.

- **Climate Use** – This includes energy used by your vehicle's high voltage climate control components such as the electric A/C compressor and the electric heater.
- **Driving and Route** – This includes energy used to propel your vehicle based on your driving style and route. Your driving style includes how fast you drive and whether your acceleration and braking is mild or aggressive. Your route includes factors such as the amount of city or highway driving and road grades.
- **Accessories** – This includes energy used for low voltage accessories such as climate system fans, heated seats and lighting.
- **Exterior Temperature** – This includes energy losses due to outside temperature and other conditions which reduce vehicle system efficiency.

How Is My Driving

Display's scores for trip driving behavior. Higher scores result in better energy economy.

- **Acceleration** – Light to moderate acceleration improves your score.
- **Braking** – We recommend slow and steady braking.
- **Speed** – Maintain reasonable vehicle speeds for best scores.



You can view additional trip data by pressing the icon on your touchscreen.

Remote Start

WHAT IS REMOTE START

The system allows you to remotely start your vehicle and to adjust the interior temperature according to the settings that you chose.

Note: If your vehicle is plugged in during the remote start operation, it will draw power from the power source and not the vehicle's battery.

REMOTE START PRECAUTIONS



WARNING: Do not keep electrical devices plugged in the power point whenever the device is not in use. Power points power up during remote start.

REMOTE START LIMITATIONS

Remote start does not work under the following conditions:

- The alarm horn is sounding.
- The hood is open.
- The vehicle is not in park (P).
- The vehicle is on.
- Remote start has been disabled in the touchscreen.
- The high voltage or 12 volt battery is below the minimum operating voltage.

Note: To use remote start with the Ford Pass, enable the modem. See **Connecting FordPass to the Modem** (page 365). To use remote start with Phone as a Key, enable the modem and set up Phone As A Key. See **Programming Your Phone** (page 65).

ENABLING REMOTE START

1.  Press the button on the touchscreen.
2. Press **Vehicle**.
3. Press **Remote Start Setup**.
4. Switch **Remote Start** on or off.

Note: To remote start with FordPass or Phone as a Key, make sure that the modem is enabled and Phone as a Key is setup. See **Enabling and Disabling the Modem** (page 365). See **Programming Your Phone** (page 65).

REMOTELY STARTING AND STOPPING THE VEHICLE

Remotely Starting the Vehicle

Using your Phone as a Key control screen, press the remote start button.

Note: You can also use the FordPass App to start the vehicle.

Note: The direction indicators flash twice.

Note: The parking lamps turn on when the vehicle is running.

Note: The horn sounds if the system fails to start.

Note: All other vehicle systems remain off when you have remotely started the vehicle.

Note: The vehicle remains secured when you have remotely started the vehicle. A valid key must be inside your vehicle to switch the vehicle on and drive your vehicle.

Note: A maximum of two remote starts are allowed. To reset the restart procedure switch the vehicle to on, then to off.

Remote Start

Remotely Stopping the Vehicle

Using your Phone as a Key control screen, press the remote stop button.

Note: You can also use the FordPass App to stop the vehicle.

Remote Start Duration

1. Press **Duration**.
2. Press the duration you prefer.

REMOTE START SETTINGS

To access the settings menu:

1.  Press the button on the touchscreen.
2. Press **Vehicle**.
3. Press **Remote Start Setup**.

Switching Climate Control Auto Mode On and Off

1. Press **Auto** or **Last settings**.

Note: If you switch the auto mode on, the system attempts to heat or cool the interior to 22°C (72°F). When you switch the vehicle on, the climate control system returns to the last used settings.

Note: If you switch the last settings on, the system remembers the last used settings.

Heated Seat Settings (If Equipped)

1. Press **Seats**.
2. Press **Auto** or **Off**.

Note: If you switch the heated seat settings on, the heated seats turn on during cold weather.

Heated Steering Wheel Settings (If Equipped)

1. Press **Seats and Steering Wheel**.
2. Press **Auto** or **Off**.

Note: If you switch the heated steering wheel settings on, the heated steering wheel turns on during cold weather.

Climate Control

IDENTIFYING THE CLIMATE CONTROL UNIT



Use the controls in this area to change the climate inside of your vehicle.

Depending on your vehicle options, the controls could look different than what you see here.

SWITCHING CLIMATE CONTROL ON AND OFF



Press the button to access the climate controls.



Press the button.

SWITCHING RECIRCULATED AIR ON AND OFF



Press the button to access the climate controls.



Press the button to recirculate air currently in the passenger compartment.

Note: Recirculated air may turn off automatically, or prevent you from switching on in all air flow modes except MAX A/C to reduce the risk of fogging. Recirculation may also turn on and off automatically in various air distribution control combinations to improve heating or cooling efficiency.

SWITCHING AIR CONDITIONING ON AND OFF



Press the button.

Note: Under certain conditions, the air conditioning compressor could continue to operate after you switch air conditioning off.

Note: To keep the system and its components fully functional, switch air conditioning on and let your vehicle idle at least once per month for a minimum of two minutes.

SWITCHING DEFROST ON AND OFF



Press the button to access the climate controls.



Press the button.

SWITCHING MAXIMUM DEFROST ON AND OFF



Press the button.

Air flows through the windshield air vents, and the blower motor adjusts to the highest speed.

Climate Control

You can also use this setting to defog and clear the windshield of a thin covering of ice.

Note: There is also a button on the lighting control.

Note: To prevent window fogging, you cannot select recirculated air when maximum defrost is on.

Note: The heated rear window also turns on when you select maximum defrost.

SWITCHING MAXIMUM COOLING ON AND OFF



Press the button to access the climate controls.



Press the button.

Note: When you switch maximum cooling off, air conditioning remains on.

Note: In certain conditions, for example, cold weather, maximum cooling may not activate or could run slow when switched on. This helps reduce power consumption from the battery.

SWITCHING THE ELECTRIC HEATER ON AND OFF

When E-Heat is on, an electric heater warms the cabin and keeps the windows from fogging. Turning E-Heat off saves battery power, which extends your driving range. The electric heater is the only source of heat to warm the cabin.



Press the button to access the climate controls.



Press the button to switch the electric heater on or off.

Note: The default setting is on.

Note: Disabling the system helps maximize your driving range.

Note: The system does not work in some climate control modes.

Note: This button does not switch off the climate control system.

Note: In certain conditions, for example warm weather, the system could not activate or could run with reduced performance when switched on.

SWITCHING THE HEATED WINDSHIELD ON AND OFF



Press the button on the touchscreen to access the climate controls.



Press the button to clear the windshield of thin ice and fog. The heated windshield turns off after a short period of time.

Note: The system does not operate if the battery charge level is low.

SWITCHING THE HEATED REAR WINDOW ON AND OFF



Press the button to clear the rear window of thin ice and fog. The heated rear window turns off after a short period of time.

Note: Do not use harsh chemicals, razor blades or other sharp objects to clean or remove decals from the inside of the heated rear window as this could cause damage to the heated rear window grid lines not covered by the vehicle Warranty.

Climate Control

SETTING THE BLOWER MOTOR SPEED

1.  Press the button on the touchscreen

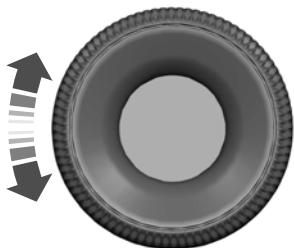

2. Turn to set the speed.

SWITCHING THE HEATED MIRRORS ON AND OFF (IF EQUIPPED)

When you switch the heated rear window on, the heated exterior mirrors turn on.

Note: Do not remove ice from the mirrors with a scraper or adjust the mirror glass when it is frozen in place.

Note: Do not clean the mirror housing or glass with harsh abrasives, fuel or other petroleum-based cleaning products. The vehicle warranty may not cover damage caused to the mirror housing or glass.

SETTING THE TEMPERATURE

1. Press the temperature controls on either side of the climate control to set the temperature for that side.

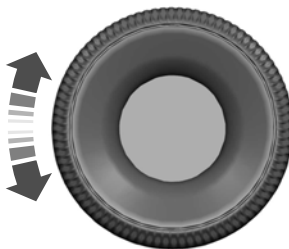

2. Turn to set the temperature.

DIRECTING THE FLOW OF AIR

Directing Air to the Windshield Air Vents



Press the button on the touchscreen to access the climate controls.



Press the button.

Directing Air to the Instrument Panel Air Vents



Press the button on the touchscreen to access the climate controls.



Press the button.

Directing Air to the Footwell Air Vents



Press the button on the touchscreen to access the climate controls.



Press the button.

Climate Control

AUTO MODE

Adjust the blower motor control or air distribution control to switch auto mode off.

SWITCHING AUTO MODE ON AND OFF



Press the button to switch auto mode on. Repeatedly press the button to adjust auto mode.

AUTO MODE INDICATORS

The indicators are on the Auto Mode button.

Auto Mode Indicator Status	Description
One indicator illuminated.	The blower motor speed is reduced. Use this setting to minimize the amount of noise from the blower motor. This setting increases the time taken to cool the interior.
Two indicators illuminated.	The blower motor speed is moderate.
Three indicators illuminated.	The blower motor speed is increased. Use this setting to reduce the time taken to cool the interior. This setting increases the amount of noise from the blower motor.

Climate Control

SWITCHING DUAL MODE ON AND OFF



Press the button to access the climate controls.



Press the button.

Note: When dual mode is off, setting the temperature using the driver side controls, sets the temperature for both sides.

Note: Setting the temperature using the passenger side controls, sets the passenger temperature and switches dual mode on.

CLIMATE CONTROL HINTS

General Hints

- Use of the climate system will reduce your vehicles driving range. Conserve battery charge by using climate control features when necessary.
- Prolonged use of recirculated air may cause the windows to fog up.
- You may feel a small amount of air from the footwell air vents regardless of the air distribution setting.
- To reduce humidity build-up inside your vehicle, do not drive with the system switched off or with recirculated air always switched on.
- Remove any snow, ice or leaves from the air intake area at the base of the windshield.
- To improve the time to reach a comfortable temperature in hot weather, drive with the windows open until you feel cold air through the air vents.

Automatic Climate Control

- Adjusting the settings when your vehicle interior is extremely hot or cold is not necessary. Automatic mode is best recommended to maintain set temperature.
- The system adjusts to heat or cool the interior to the temperature you select as quickly as possible.
- For the system to function efficiently, the instrument panel and side air vents should be fully open.
- If you press **AUTO** during cold outside temperatures, the system directs air flow to the windshield and side window air vents. The blower motor speed may reduce until the air warms.
- If you press **AUTO** during hot temperatures and the inside of the vehicle is hot, the system uses recirculated air to maximize interior cooling. Blower motor speed may also reduce until the air cools.

Quickly Heating the Interior

1. Press **AUTO**.
2. Adjust the temperature function to the setting you prefer.

Recommended Settings for Heating

1. Press **AUTO**.
2. Adjust the temperature function to the setting you prefer. Use 22°C (72°F) as a starting point, then adjust the setting as necessary.

Quickly Cooling the Interior

Press **MAX A/C**.

Recommended Settings for Cooling

1. Press **AUTO**.

Climate Control

2. Adjust the temperature function to the setting you prefer. Use 22°C (72°F) as a starting point, then adjust the setting as necessary.

Defogging the Side Windows in Cold Weather

1. Press and release defrost or maximum defrost.
2. Adjust the temperature control to the setting you prefer. Use 22°C (72°F) as a starting point, then adjust the setting as necessary.

Interior Air Quality

WHAT IS THE CABIN AIR FILTER

The cabin air filter improves the quality of air in your vehicle by trapping dust, pollen and other particles.

REPLACING THE CABIN AIR FILTER

Replace the filter at regular intervals.

The cabin air filter is behind the glove compartment.

To remove the lower glove compartment and access the filter:

1. Open the glove compartment.
2. Detach the damper by depressing the tabs and pulling it away from the glove compartment.

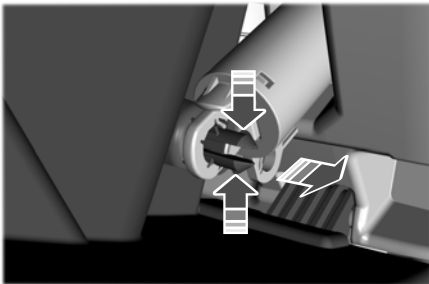

3. Press the tabs on each side to release the glove compartment.

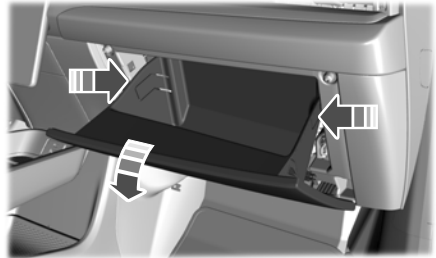

4. Fully lower the glove compartment.
5. Unclip both sides of the filter door and swing door down to access filter.

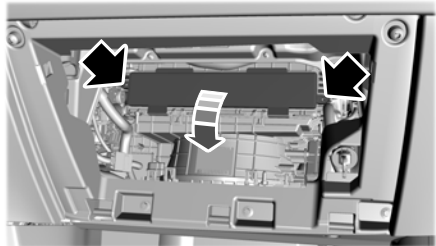

6. Remove the old filter and replace with a new filter.

Front Seats

FRONT SEAT PRECAUTIONS



WARNING: Sitting improperly, out of position or with the seatback reclined too far can take weight off the seat cushion and affect the decision of the passenger sensing system, resulting in serious injury or death in the event of a crash. Always sit upright against your seat back, with your feet on the floor.



WARNING: Do not recline the seat backrest too far as this can cause the occupant to slide under the seatbelt, resulting in personal injury in the event of a crash.



WARNING: Do not place objects higher than the top of the seat backrest. Failure to follow this instruction could result in personal injury or death in the event of a sudden stop or crash.



WARNING: Do not adjust the driver seat or seat backrest when your vehicle is moving. This may result in sudden seat movement, causing the loss of control of your vehicle.

SITTING IN THE CORRECT POSITION

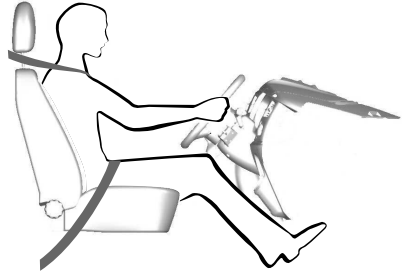

When you use them properly, the seat, head restraint, seatbelt and airbags will provide optimum protection in the event of a crash.

We recommend that you follow these guidelines:

- Sit in an upright position with the base of your spine as far back as possible.
- Do not recline the seat backrest so that your torso is more than 30 degrees from the upright position.
- Adjust the head restraint so that the top of it is level with the top of your head and as far forward as possible. Make sure that you remain comfortable.
- Keep sufficient distance between yourself and the steering wheel. We recommend a minimum of 25 cm (10 in) between your breastbone and the airbag cover.
- Hold the steering wheel with your arms slightly bent.

Front Seats

- Bend your legs slightly so that you can press the pedals fully.
- Position the shoulder strap of the seatbelt over the center of your shoulder and position the lap strap tightly across your hips.

Make sure that your driving position is comfortable and that you can maintain full control of your vehicle.

MANUAL SEATS

HEADRESTRAINT COMPONENTS

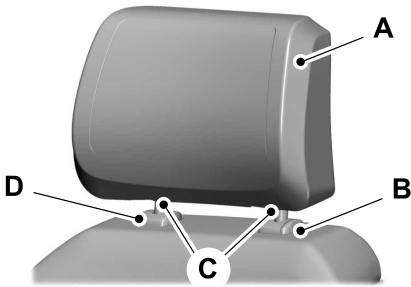

The head restraints consist of:

- A An energy absorbing head restraint.
- B Guide sleeve adjust and release button.
- C Two steel stems.
- D Guide sleeve unlock and remove button (If equipped).

ADJUSTING THE HEAD RESTRAINT

4-Way Head Restraints

WARNING: Fully adjust the head restraint before you sit in or operate your vehicle. This will help minimize the risk of neck injury in the event of a crash. Do not adjust the head restraint when your vehicle is moving.

WARNING: The head restraint is a safety device. Whenever possible it should be installed and properly adjusted when the seat is occupied. Failure to adjust the head restraint properly could reduce its effectiveness during certain impacts.

WARNING: Adjust the head restraints for all passengers before you drive your vehicle. This will help minimize the risk of neck injury in the event of a crash. Do not adjust the head restraints when your vehicle is moving.

Note: Adjust the seat backrest to an upright driving position before adjusting the head restraint. Adjust the head restraint so that the top of it is level with the top of your head. Make sure that you remain comfortable. If you are tall, adjust the head restraint to its highest position.

Pull the head restraint up to raise it.

To lower the head restraint:

1. Press and hold the adjust and release button.
2. Push the head restraint down.

The head restraints may tilt for extra comfort. To tilt the head restraint:

Front Seats



1. Adjust the seat backrest to an upright driving or riding position.
2. Pivot the head restraint forward toward your head to the preferred position.

After the head restraint reaches the forward-most tilt position, pivot it forward again to release it to the rearward, untilted position.

Note: Do not attempt to force the head restraint backward after it is tilted. Instead, continue tilting it forward until the head restraint releases to the upright position.

REMOVING THE HEAD RESTRAINT

1. Pull up the head restraint until it reaches its highest position.
2. Press and hold the adjust and release button and the unlock and remove button - if equipped.
3. Pull up the head restraint.

INSTALLING THE HEAD RESTRAINT

Align the steel stems into the guide sleeves and push the head restraint down until it locks.

MOVING THE SEAT BACKWARD AND FORWARD

 **WARNING:** Make sure the seat fully locks into place by rocking it backward and forward. Not securing the seat into the locked position can be dangerous in a crash and could cause serious personal injury or death.



ADJUSTING THE SEAT BACKREST

 **WARNING:** Do not place cargo or any objects behind the seatback before returning it to the original position.

 **WARNING:** Reclining the seatback can cause an occupant to slide under the seat's seatbelt, resulting in severe personal injuries in the event of a crash.

Front Seats



ADJUSTING THE SEAT HEIGHT (if Equipped)

[Manual Seat Adjustment](#)



POWER SEATS

HEADRESTRAINT COMPONENTS

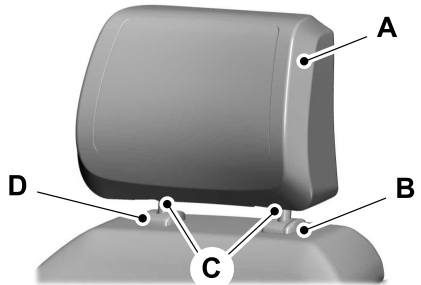

The head restraints consist of:

- A An energy absorbing head restraint.
- B Guide sleeve lock and release button.
- C Two steel stems.
- D Guide sleeve.

ADJUSTING THE HEAD RESTRAINT - VEHICLES WITH: FRONTFIXED HEADRESTRAINTS



Front Seats

The non-adjustable head restraints consist of a trimmed foam pad and plastic finish panels covering the upper structure of the seat backrest.

Properly adjust the seat backrest to an upright driving or riding position, so that the head restraint is positioned as close as possible to the back of your head.

ADJUSTING THE HEAD RESTRAINT - VEHICLES WITH: FRONT ADJUSTABLE HEAD RESTRAINTS

4-Way Head Restraints



WARNING: Fully adjust the head restraint before you sit in or operate your vehicle. This will help minimize the risk of neck injury in the event of a crash. Do not adjust the head restraint when your vehicle is moving.



WARNING: The head restraint is a safety device. Whenever possible it should be installed and properly adjusted when the seat is occupied. Failure to adjust the head restraint properly could reduce its effectiveness during certain impacts.



WARNING: Adjust the head restraints for all passengers before you drive your vehicle. This will help minimize the risk of neck injury in the event of a crash. Do not adjust the head restraints when your vehicle is moving.

Note: *Adjust the seat backrest to an upright driving position before adjusting the head restraint. Adjust the head restraint so that the top of it is level with the top of your head. Make sure that you remain comfortable. If you are tall, adjust the head restraint to its highest position.*

Pull the head restraint up to raise it.

To lower the head restraint:

1. Press and hold the adjust and release button.
2. Push the head restraint down.

The head restraints may tilt for extra comfort. To tilt the head restraint:



1. Adjust the seat backrest to an upright driving or riding position.
2. Pivot the head restraint forward toward your head to the preferred position.

After the head restraint reaches the forward-most tilt position, pivot it forward again to release it to the rearward, untilted position.

Note: *Do not attempt to force the head restraint backward after it is tilted. Instead, continue tilting it forward until the head restraint releases to the upright position.*

REMOVING THE HEAD RESTRAINT

1. Pull up the head restraint until it reaches its highest position.
2. Press and hold the adjust and release button.
3. Pull up the head restraint.

Front Seats

INSTALLING THE HEAD RESTRAINT

Align the steel stems into the guide sleeves and push the head restraint down until it locks.

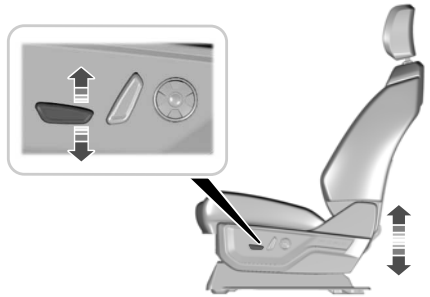

MOVING THE SEAT BACKWARD AND FORWARD

Power-Seat Adjustment

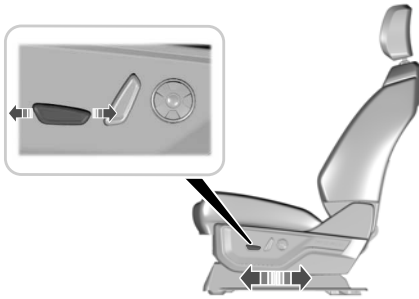

ADJUSTING THE LUMBAR SUPPORT

Power-Seat Adjustment

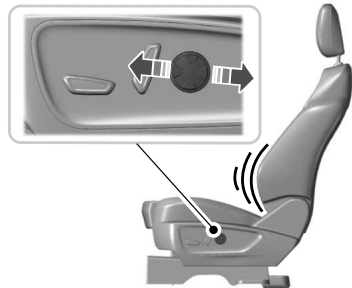

ADJUSTING THE SEAT BACKREST

Power-Seat Adjustment



ADJUSTING THE SEAT HEIGHT

Power-Seat Adjustment

Front Seats

HEATED SEATS (IF EQUIPPED)

HEATED SEAT PRECAUTIONS



WARNING: Use caution when using the heated seat if you are unable to feel pain to your skin because of advanced age, chronic illness, diabetes, spinal cord injury, medication, alcohol use, exhaustion or other physical conditions. The heated seat could cause burns even at low temperatures, especially if used for long periods of time. Failure to follow this instruction could result in personal injury.



WARNING: Do not poke sharp objects into the seat cushion or seat backrest. This could damage the heated seat element and cause it to overheat. Failure to follow this instruction could result in personal injury.



WARNING: Do not place anything on the seat that blocks the heat, for example a seat cover or a cushion. This could cause the seat to overheat. Failure to follow this instruction could result in personal injury.



Press the heated seat symbol, then select your preferred heat level or off. The more indicators that display, the warmer the temperature of the seat.

Note: Based on your remote start settings, the heated seats may remain on after you remote start your vehicle. The heated seats may also turn on when you start your vehicle if they were on when you switched your vehicle off.

Automatic Heated Seats (If Equipped)

When you switch on the auto setting, the heated seats switch on to match your climate control setting.

Do not:

- Place heavy objects on the seat.
- Operate the heated seat if water or any other liquid spills on the seat. Allow the seat to dry.

SWITCHING THE HEATED SEATS ON AND OFF

The vehicle must be on to use this feature.

Rear Seats

MANUAL SEATS

HEADRESTRAINT COMPONENTS

Rear Seat Outermost Head Restraints

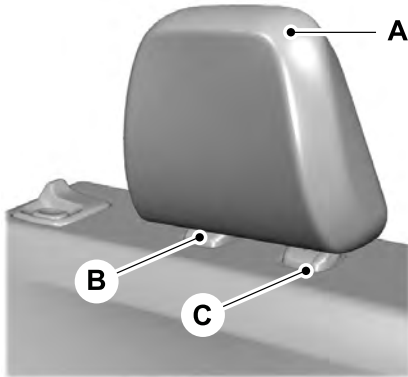

The head restraint consists of:

- A An energy absorbing head restraint.
- B Two steel stems.
- C Guide sleeve adjust and release button.
- D Guide sleeve unlock and remove button (If equipped).

ADJUSTING THE HEAD RESTRAINT

The outermost head restraints are non-adjustable.

Pull the center head restraint up to raise it.

To lower the center head restraint:

1. Press and hold the adjust and release button.
2. Push the head restraint down.

The head restraints consist of:

- A An energy absorbing head restraint.
- B Guide sleeve.
- C Locking guide sleeve.

Rear Seat Center Head Restraint

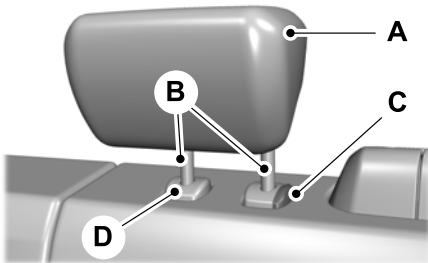

REMOVING THE HEAD RESTRAINT

1. Fold the seat backrest forward before removing the head restraint.
2. Pull up the head restraint until it reaches its highest position.
3. Press and hold the adjust and release button and the unlock and remove button - if equipped.
4. Pull up the head restraint.

INSTALLING THE HEAD RESTRAINT

1. Fold the seat backrest forward before installing the head restraint.
2. Align the steel stems into the guide sleeves and push the head restraint down until it locks.

Rear Seats

FOLDING THE SEAT BACKREST



WARNING: To prevent possible damage to the seat or seatbelts, make sure that the seatbelts are not fastened before folding the seatback.



WARNING: When folding or unfolding the seats, take care not to get your fingers caught between the seat backrest and seat frame. Failure to follow this warning could result in serious personal injury.



Press the button and fold the seat backrest forward.

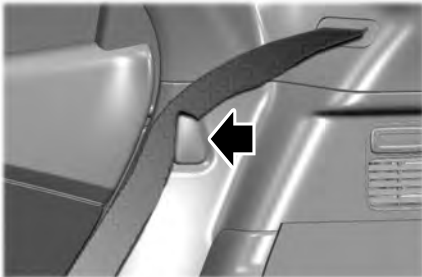

When the rear outermost seat backrests are folded, place the seatbelts in the stowage clip. This prevents the seatbelt from getting caught when the backrest is unfolded.

UNFOLDING THE SEAT BACKREST



WARNING: When unfolding the seat backrests, make sure that the seatbelts are not trapped behind the seat.



WARNING: Make sure that the seats and the seat backrests are secure and fully locked in their catches.

Lift the seat backrest up to unfold it. Make sure the seat latch engages.

Rear Occupant Alert System (If Equipped)

WHAT IS THE REAR OCCUPANT ALERT SYSTEM

The rear occupant alert system monitors vehicle conditions and notifies you to check for rear seat occupants when you switch the ignition off.

HOW DOES THE REAR OCCUPANT ALERT SYSTEM WORK

The system monitors when rear doors have been opened and closed to indicate the potential presence of an occupant in the rear seat.

A message displays in the information and entertainment display screen and an audible warning sounds when you switch the ignition off after any of the following conditions have been met:

- A rear door is opened or closed while the ignition is on.
- You switch the ignition on within 15 minutes of a rear door opening and closing.
- You switch the ignition on within 15 minutes of the alert having displayed or sounded.

REAR OCCUPANT ALERT SYSTEM PRECAUTIONS



WARNING: On hot days, the temperature inside the vehicle can rise very quickly. Exposure of people or animals to these high temperatures for even a short time can cause death or serious heat related injuries, including brain damage. Small children are particularly at risk.



WARNING: Do not leave children or pets unattended in your vehicle. Failure to follow this instruction could result in personal injury or death.

REAR OCCUPANT ALERT SYSTEM LIMITATIONS

The system does not detect the presence of objects or passengers in the rear seat. It monitors when rear doors are opened and closed.

Note: *It is possible to receive an alert when there is no rear seat occupant, but alert conditions are met.*

Note: *It is possible to receive no alert when there is an occupant in the rear seat, if alert conditions are not met. For example, if a rear seat occupant does not enter the vehicle through a rear door.*

Note: *The audible warning does not sound when the front door is opened before you switch the ignition off.*

SWITCHING REAR OCCUPANT ALERT SYSTEM ON AND OFF

1.  Press the button on the touchscreen.
2. Press **Vehicle**.
3. Switch **Rear Occupant Alert** on or off.

Note: *The default setting is on.*

Note: *Performing a master reset causes the system to switch on again.*

Rear Occupant Alert System (If Equipped)

Semiannual Reminder (If Equipped)

When you switch the system off, a message appears every six months as a reminder that the system is off. You can switch the system back on or leave it off.

The warning sounds for a short period of time.

REAR OCCUPANT ALERT SYSTEM INDICATORS

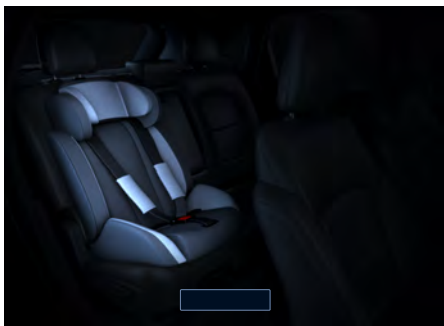

Message
Check rear seats for occupants.

Displays when you switch your vehicle off after the alert conditions are met.

The message displays for a short period of time. Press **Close** to acknowledge and remove the message.

Note: Depending on your SYNC version, the graphic may look different from what you see here.

REAR OCCUPANT ALERT SYSTEM AUDIBLE WARNINGS

Sounds when you switch your vehicle off after the alert conditions are met.

Memory Function (If Equipped)

WHAT IS THE MEMORY FUNCTION

The memory function recalls the position of these features:

- Driver seat.
- Power mirrors.

MEMORY FUNCTION PRECAUTIONS



WARNING: Before activating the memory seat, make sure that the area immediately surrounding the seat is clear of obstructions and that all occupants are clear of moving parts.



WARNING: Do not use the memory function when your vehicle is moving.

LOCATING THE MEMORY FUNCTION BUTTONS



The memory function buttons are on the driver door.

SAVING A PRESET POSITION

1. Switch the vehicle on.
2. Adjust the memory features to your preferred position.
3. Press and hold the preferred preset button until you hear a single tone.

A confirmation message appears in the information display.

You can save up to three preset memory positions at any time.

RECALLING A PRESET POSITION

Press and release a preset button.

Note: You can recall a preset memory position when the vehicle is off, or when you place the transmission in park (P) or neutral (N) if the vehicle is on and it is not moving.

Note: Pressing any of the preset buttons during a memory recall cancels the operation.

You can also recall a preset memory position by:

- Pressing the unlock button on your remote control if you linked it to a preset position.
- Unlocking the intelligent driver door handle if a linked remote control is present.

Using a linked remote control to recall your memory position when the vehicle is off moves the seat and steering column to the easy entry position.

Linking a Preset Position to your Remote Control or Passive Key

See **Linking or Unlinking a Personal Profile** (page 386).

USB Ports

LOCATING THE USB PORTS

USB A



USB C



Data Transfer USB Ports



The USB ports are in the following locations:

- On the lower instrument panel.
- Inside the media bin.
- Inside the center console.

Note: *These USB ports can also charge devices.*

Note: *Not all USB ports in your vehicle have data transfer capabilities.*

Note: *We recommend using only USB-IF certified cables and adapters. Non-certified cables and adapters may not work.*

Charge Only USB Ports



The USB ports are in the following locations:

- Inside the media bin below the instrument panel.
- Inside the center console.
- On the rear of the center console.
- In the cargo area.

PLAYING MEDIA USING THE USB PORT





 **WARNING:** Driving while distracted can result in loss of vehicle control, crash and injury. We strongly recommend that you use extreme caution when using any device that may take your focus off the road. Your primary responsibility is the safe operation of your vehicle. We recommend against the use of any hand-held device while driving and encourage the use of voice-operated systems when possible. Make sure you are aware of all applicable local laws that may affect the use of electronic devices while driving.

1. Connect your device to the USB port.
- 2.



Press the button on the touchscreen to open the application drawer.

USB Ports

3.  Press the USB option.
-  Press the button to play a track.
Press the button again to pause the track.
-  Press the button to skip to the next track.
Press and hold the button to fast forward through the track.
-  Press the button once to return to the beginning of a track.
Repeatedly press the button to return to previous tracks.
Press and hold the button to fast rewind.

CHARGING A DEVICE

Connect your device to the USB port.

Data Transfer USB Ports



You can charge your device through the data transfer USB port when SYNC is on.

Charge Only USB Ports



You can charge your device through the charge only USB port when the vehicle is in accessory mode or when the vehicle is running.

Power Outlet

WHAT IS THE POWER OUTLET

The power outlet can power devices using a 12 V outlet adapter.

POWER OUTLET PRECAUTIONS

When you switch the vehicle on, you can use the socket to power 12 V appliances with a maximum current rating of 20 A. Do not use the power point over the vehicle capacity of 12 V DC 240 W or a fuse could blow. Do not plug in any device that supplies power to the vehicle through the power points. This could result in damage to vehicle systems. Do not hang any accessory from the accessory plug. Always keep the power point caps closed when not in use. Do not insert objects other than an accessory plug into the power point.

To prevent the battery from running out of charge:

- Do not use the power point longer than necessary when the vehicle is off.
- Do not leave devices plugged in overnight or when you park your vehicle for extended periods.

LOCATING THE POWER OUTLETS

Power outlets are in the following locations:

- In the media bin below the instrument panel.
- Inside the main center console bin.
- On the rear of the main center console bin.
- In the cargo area.

Wireless Accessory Charger

WHAT IS THE WIRELESS ACCESSORY CHARGER

The wireless accessory charger allows you to charge one compatible Qi wireless charging device on the charging area.

WIRELESS ACCESSORY CHARGER PRECAUTIONS



WARNING: Wireless charging devices can affect the operation of implanted medical devices, including cardiac pacemakers. If you have any implanted medical devices, we recommend that you consult with your physician.

Keep the charging area clean and remove foreign objects prior to charging a device.

Do not place items with a magnetic strip or radio-frequency identification chip, for example passports, parking tickets, transportation passes or credit cards, near the charging area when charging a device. Damage could occur to the magnetic strip or radio-frequency identification chip.

Do not place metal objects, for example remote controls, coins and candy wrappers, on or near the charging area when charging a device. Metal objects may heat up and degrade the charging performance, in addition to causing interruptions in charging.

Charging could be interrupted, degraded, or could stop if any of the following occur:

- The system detects a foreign object.
- The device is misaligned on the charging area.
- The device moves on the active charging area when the vehicle is in motion.

- The vehicle ambient temperature is too high.
- You attempt to charge a non-Qi compatible device on the wireless charger.

Note: *During charging, the device and the charger could heat up, this is normal. If the battery gets hotter than usual, the device may stop charging.*

LOCATING THE WIRELESS ACCESSORY CHARGER



The charging area is in the front console below the instrument panel.

CHARGING A WIRELESS DEVICE

Place the device on the center of the charging surface with the charging side down. The charging stops after your device reaches a full charge.

You can use the charger when the vehicle is in accessory mode, when the vehicle is running, or when SYNC is on.



Displays on the status bar when wireless charging is in progress.

Note: *The charging performance may be affected if your device is in a case. It may be necessary to remove the case to wirelessly charge your device.*

Note: *Software and firmware updates may affect device compatibility, including the use of unofficial software or firmware. You should verify charging functionality with your specific devices in-vehicle.*

Storage

CUP HOLDERS

CUP HOLDER PRECAUTIONS



WARNING: Use caution when stowing items or hot drinks in the cup holders. Items could become loose or spill during hard braking, acceleration or crashes. Failure to follow this instruction could result in personal injury.

GLOVE COMPARTMENT

OPENING THE GLOVE COMPARTMENT

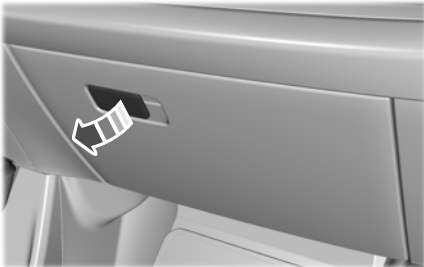

Pull the latch to the left to open the glove compartment.

GLASSES HOLDER

LOCATING THE GLASSES HOLDER

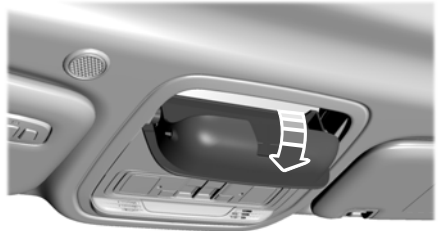

The glasses holder is in the overhead console.

Press near the rear edge of the door to open it.

Starting and Powering Off

STARTING AND POWERING OFF PRECAUTIONS

- The system may not function if the remote control is close to metal objects or electronic devices, such as keys or a cell phone.
- A valid remote control must be inside your vehicle to switch the power on and start your vehicle.
- Remote controls left inside your vehicle when locked are disabled. A message may appear in the information display indicating that there is no key detected when you try to start your vehicle. Press the unlock button on the remote control to enable it, and then start your vehicle.
- Make sure all occupants fasten their seat belt.
- Make sure the headlamps and electrical accessories are off.
- Make sure the parking brake is on.
- Make sure the vehicle is in park (P).

STARTING THE VEHICLE

1. Fully press the brake pedal.

Note: Do not touch the accelerator pedal.



2. Press the push button start.

You can also start your vehicle using Valet Mode or a Backup Start Passcode. See **Phone as a Key** (page 65).

POWERING OFF



WARNING: Do not switch off your vehicle when it is moving. This results in a significant decrease in braking and steering assistance. If the vehicle is switched off, some electrical circuits, for example airbags, could also turn off. Failure to follow this instruction could result in the loss of control of your vehicle, personal injury or death.

Note: If you unintentionally switch your vehicle off, shift into neutral (N) and restart your vehicle.

When your vehicle is not moving and is started, or the power is in accessory mode, press and release the push button start without pressing the brake pedal. This shuts off the vehicle and all electrical accessories.

When your vehicle is moving, press the push button start three times within two seconds, or press and hold for at least one second. Shift into neutral (N) and use the brakes to bring your vehicle to a safe stop. When your vehicle comes to a complete stop, shift into park (P).

RESTARTING THE VEHICLE AFTER POWERING OFF

Fast Restart

The fast restart feature allows you to restart your vehicle within 10 seconds of switching it off, even if it does not detect a valid remote control.

Starting and Powering Off

Within 10 seconds of switching your vehicle off, press the brake pedal and press the push button start. After 10 seconds, you can no longer start your vehicle if it does not detect a valid remote control.

Once your vehicle starts, it remains on until you press the push button start, even if it does not detect a valid remote control.

If you open and close a door while your vehicle is on, the system searches for a valid remote control. You cannot start your vehicle if the system does not detect a valid remote control within 10 seconds.

ACCESSING THE PASSIVE KEY BACKUP POSITION

If you are unable to start your vehicle, follow the steps below.



1. Open the floor console storage compartment lid.
2. Place the remote control in the slot as shown with the buttons facing upward.

3. With the remote control in this position, press the brake pedal, then press the push button start to switch the power on and start your vehicle.

STARTING AND POWERING OFF – TROUBLESHOOTING

STARTING AND POWERING OFF – FREQUENTLY ASKED QUESTIONS

Why does the vehicle not start?

The system does not function if the remote control frequencies are jammed, or if the remote control battery has no charge. See **Accessing the Passive Key Backup Position** (page 157).

High Voltage Battery

WHAT IS THE HIGH VOLTAGE BATTERY

The high voltage battery is a highly sophisticated lithium ion battery system, used to store electrified energy to power your vehicle.

HIGH VOLTAGE BATTERY PRECAUTIONS



WARNING: This battery pack should only be serviced by an authorized electric vehicle technician. Improper handling can result in personal injury or death.



WARNING: Keep your hands and clothing clear of the cooling fan.

Your vehicle consists of various high-voltage components and wiring. All of the high-voltage power flows through specific wiring assemblies labeled as such or covered with a solid orange convolute, or orange striped tape, or both. Do not come in contact with these components.

PRESERVING YOUR HIGH VOLTAGE BATTERY

When using the battery at a low state of charge, your vehicle could start disabling accessory features to protect battery life.

If your vehicle reaches a 0% state of charge, recharge your vehicle as soon as possible.

In everyday use it is acceptable to use the full state of charge window, however there are a few best practices we recommend in order to maintain the health and life of your battery.

Overnight Charging

You can increase the longevity and performance of your high voltage battery by using the charge scheduling and departure and comfort settings on your touchscreen or in the FordPass app.

With Charge Scheduling you can improve the high voltage battery's longevity by delaying the start of charging and setting a maximum charging limit. It is recommended to set your preferred charging times to be at least 2-3 hours after your typical plug in time. This allows the battery to cool before charging begins. Additionally, setting the maximum charge level to 90% for everyday usage reduces strain on the battery.

You can improve driving range and performance by scheduling departure times and cabin comfort level with the Departure and Comfort feature. This will not only warm or cool the cabin but also condition the battery to ensure best driving range and performance by the set departure time.

DC Charging

Frequent use of DC charging could result in reducing your battery's efficiency and lifespan. This is more pronounced on the standard range battery pack versus the extended range battery pack. See **What is DC Charging** (page 161).

Storage Temperature

Storing your vehicle in temperatures between 0°C (32°F) and 45°C (113°F) is the most beneficial for the high voltage battery.

At temperatures just above the freezing point or lower, you should plug your vehicle in to maintain battery performance and maximize driving range.

High Voltage Battery

Storage State of Charge

You can increase the battery life by maintaining the state of charge below 100%. When you park your vehicle for an extended period of 30 days or more, we recommend the battery state of charge be at approximately 50%. Storing your vehicle's high voltage battery at higher states of charge is less favorable than storing at lower states of charge.

Note: *To achieve this state of charge for storage, you can drive your vehicle down to 50% and set a charge limit for your location. See **Setting the Charging Schedule and Preferences** (page 180).*

RECYCLING AND DISPOSING OF THE HIGH VOLTAGE BATTERY

Please recycle in accordance with local regulations.

ENERGY CONSUMPTION FIGURES

Energy Consumption

The declared WLTP energy consumptions, CO₂-Emissions and electric range are determined according to the technical requirements and specifications of the European Regulations (EC) 715/2007 and (EU) 2017/1151 as last amended. The applied standard test procedures enable comparison between different vehicle types and different manufacturers. Comparisons between WLTP-tested and NEDC-tested vehicles should not be made in relation to electric range and electricity consumption.

European Directive 1999/94/EC

In addition to the fuel efficiency of a car, driving behavior as well as other non-technical factors play a role in determining a car's fuel/energy consumption, CO₂ emissions and electric range. CO₂ is the main greenhouse gas responsible for global warming.

ENERGY CONSUMPTION FIGURES - EXCLUDING: GT

Electric Range City	Electric Range	Electric Energy Consumption	Weighted, Combined CO ₂
km (mi)	km (mi)	kWh/100km (mi/kWh)	g/km
480-739 (298-459)	400-610 (249-379)	16.5-19.5 (3.8-3.2)	0

High Voltage Battery

ENERGY CONSUMPTION FIGURES - GT

Electric Range City	Electric Range	Electric Energy Consumption	Weighted, Combined CO ₂
km (mi)	km (mi)	kWh/100km (mi/kWh)	g/km
588 km (365.4 mi)	500 km (310.7 mi)	20 (3.1)	0

HIGH VOLTAGE BATTERY – TROUBLESHOOTING

HIGH VOLTAGE BATTERY – WARNING LAMPS



Illuminates when the powertrain requires service. Have the system checked as soon as possible.

Charging Your Vehicle

WHAT IS AC CHARGING

AC charging is the preferred method of charging. AC charging preserves the health of the high voltage battery for longer high voltage battery life.

WHAT IS DC CHARGING

DC charging allows you to charge the vehicle's high voltage battery in significantly less time than the standard charge method. You can charge on the go before the battery has exhausted all of its power, or when traveling using the trip planner as part of your FordPass App.

For the convenience of DC charging and time, there is a different fee structure depending on the charging station and network you choose.

Note: *Charge times vary depending on outside air temperature, power level, charger type, and location in which you are charging.*

Note: *The system could reduce the DC charging rate to maximize the life of the battery.*

CHARGING YOUR VEHICLE PRECAUTIONS

 **WARNING:** Do not allow charging equipment to be immersed in water or liquids. Failure to follow this warning could result in fire, serious personal injury or death.

 **WARNING:** Do not attempt to open the charging equipment. Failure to follow this instruction could result in personal injury, death or property damage.

 **WARNING:** Do not use the charging equipment if it is faulty or has been damaged. Failure to follow this instruction could result in personal injury, death or property damage.

 **WARNING:** Install charging equipment in compliance with local regulations. Failure to follow this warning could result in fire, serious personal injury or death.

CHARGING EQUIPMENT

 **WARNING:** Do not use an ungrounded wall outlet. The wall outlet must be in good condition and meet up-to-date local codes. Have a qualified electrician check the wall outlet, if you suspect that it is not properly grounded. Failure to follow this instruction could result in electric shock, personal injury, or death.

 **WARNING:** It is recommended that electrical outlets for use with your charging equipment be installed by a licensed, qualified electrician. Installations must comply with the provisions of all local codes. Failure to follow this warning could result in personal injury or death.

 **WARNING:** Do NOT DROP the control box or coupler.

 **WARNING:** Do NOT use if stored outside temperature range specified.

 **WARNING:** Do not attempt to repair the charging equipment. Contact your local dealer for assistance.

Charging Your Vehicle

 **WARNING:** Read all warnings on the charging equipment before using for the first time.

 **WARNING:** Read all instructions in this publication before using the charging equipment.

 **WARNING:** Do not use the charging equipment with an extension cord, surge protector, timer or other adapter. Failure to follow this instruction could result in electric shock or fire.

 **WARNING:** The wall plug must fit firmly into the outlet. If the connection feels loose, worn or the outlet is damaged, have a qualified electrician replace the outlet. Using charging equipment with a worn outlet may cause burns, property damage and increase the risk of electric shock.

 **WARNING:** Fully insert the plug into the wall outlet. Failure to follow this instruction could result in electric shock.

 **WARNING:** Children should be supervised when in the vicinity of the charging equipment while plugged in.

 **WARNING:** Do not put fingers into the electric charge coupler. Failure to follow this instruction could result in electric shock.

 **WARNING:** This equipment has arcing or sparking parts. Do not expose to flammable vapors. Position this equipment at least 450 mm (18 in) above the floor.

 **WARNING:** Do not connect or disconnect any pluggable components of the charging equipment when in use or charging. Failure to follow this instruction can cause damage to the charging equipment.

 **WARNING:** Do not use the charging equipment in temperatures outside of the operation range of -30°C (-22°F) to 50°C (122°F).

 **WARNING:** Store the charging equipment in a clean dry place between the temperatures of -30°C (-22°F) to 85°C (185°F).

 **WARNING:** Do not plug the charging equipment into an electrical outlet that is submerged in water or covered in snow.

 **WARNING:** Do not use charging equipment in severe rain, snow or electrical storm.

 **WARNING:** Do not allow charging equipment to be immersed in water or liquids. Failure to follow this warning could result in fire, electric shock, or serious personal injury or death.

 **WARNING:** When using the charging equipment avoid moisture, water, snow and foreign objects at all times.

 **WARNING:** Do not replace the plug on the connector. There are critical safety devices in the plug, and the charging equipment will not operate, if the plug is replaced. Failure to follow this instruction could result in electric shock, personal injury, death, or fire.

Charging Your Vehicle



WARNING: Charging equipment contains no user modifiable or repairable parts. If the charging equipment plug does not properly fit into the wall outlet, have a qualified electrician install the correct wall outlet. Failure to follow this instruction could result in personal injury or death.



WARNING: High voltage is present in your electric meter housing and power distribution service panel. Contact with high voltage can cause death or serious personal injury.



WARNING: Visually inspect the charging equipment before each use. Do not use the charging equipment if it is damaged.



WARNING: Keep charging equipment inside when not in use. Store the control box on the hanger or all the charging equipment in the bag after use to prevent damage to the charging equipment and personal injury.

Your vehicle comes with a universal home charge cord that has a low power connector to use with a 230V outlet. A high power connector can be purchased separately as an accessory. Connector type varies by market.

Specification Type	Specification Value
Charger Model	IEC
Voltage	230 VAC
Maximum Current	32 amps max continuous
Frequency	50Hz
Power draw when idle	< 2 Watts

Specification Type	Specification Value
Power draw when charging	< 4 Watts
Cable length	6.1 m (20 ft)
Weight	4.2 kg (9.3 lb)
Operating temperature	-30°C (-22°F) to 50°C (122°F)
Storage temperature	-30°C (-22°F) to 85°C (185°F)
CCID Environmental	IP67
Ventilation	Not required
Maximum Altitude	4000m

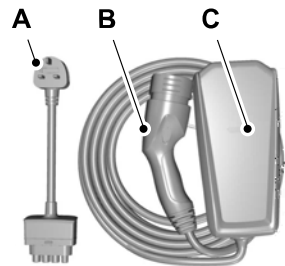

- A Connector.
- B Coupler.
- C Control Box.

The universal home charge cord is in the rear luggage compartment under the load floor and allows you to charge the vehicle's battery using a standard household outlet.

You must plug the connector into the control box first. Then plug the connector into the household outlet, and then plug into the vehicle charge port.

Charging Your Vehicle

The power indicator illuminates blue when the connector is properly inserted into the control box and dedicated wall outlet.

Note: To insert the connector, firmly grasp the connector by the cable or plug and push into the control box until an audible click is heard. Make sure the connector is fully inserted and flush with the control box before inserting it into the outlet. Improper insertion causes a longer charge session or faults.

Note: Follow the installation instructions provided with the charger.

Note: We recommend using the supplied plugs and connectors.

Note: Use the correct connector for the appropriate market in which you are charging your vehicle.

Note: If you do not use a dedicated circuit, the circuit breaker could trip or open. If a dedicated circuit is not available, contact a licensed professional electrician regarding the installation of a dedicated outlet.

Note: The universal home charge cord will not charge and give a fault indication, if ground is not present.

Note: Plug the connector for the universal home charge cord directly into the wall plug receptacle. Do not plug the universal home charge cord into any form of extension cord.

Note: If the wall bracket is not used for mounting the charging equipment, plug the charging equipment into an outlet closer to ground.

Charge Connector Types

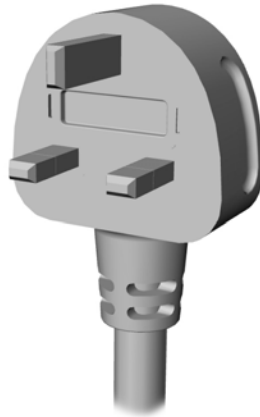

UK, Ireland

Charging Your Vehicle

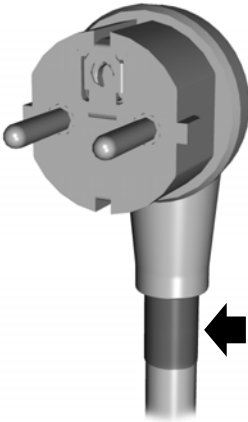

No color band: Austria, Belgium, Czech Republic, Germany, Greece, Hungary, Netherlands, Poland, Portugal, Romania, Spain, Sweden
Blue color band: Finland, France
Orange color band: Norway

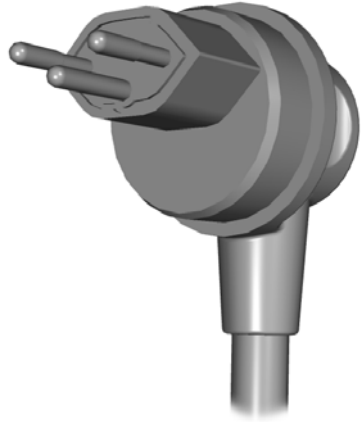

Switzerland



Italy

Charging Your Vehicle

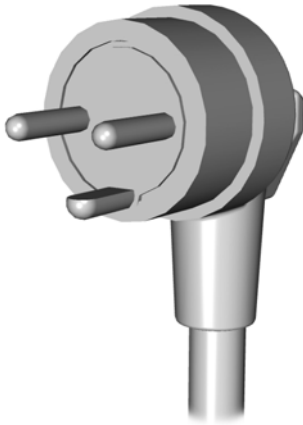

Denmark

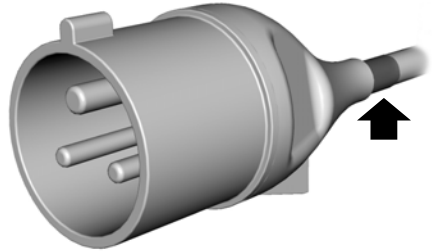

No color band: UK, Ireland

Blue color band: Austria,
Belgium, Czech Republic,
Denmark, Finland, France,
Germany, Greece, Hungary, Italy,
Netherlands, Poland, Portugal,
Romania, Spain, Sweden,
Switzerland

Orange color band: Norway

Charging Your Vehicle

Knowing Your Universal Home Charge Cord Indicator Lights

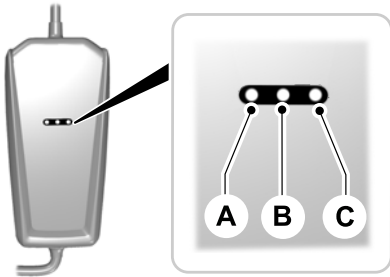

- A Amber fault indicator
- B Blue status indicator
- C Red trouble indicator

Universal Home Charge Cord Fault Indicator Type	Indicator Description
AMBER	The amber fault indicator illuminates to communicate that the charger is rebooting after an error.
BLUE	When plugged into the wall outlet, the blue indicator illuminates to communicate that the charger is ready to use.
RED	The red indicator illuminates when the charger has detected an error. If the red indicator is illuminated, the charger will not deliver power to the vehicle. The error must be corrected before a charging cycle can begin or continue.

Note: When first plugged into a wall outlet the amber, blue and red indicators blink once. Then the blue indicator turns on, followed by a blink of the red indicator. After, the blue indicator turns off then back on. This cycle happens twice if a different connector is used from a previous charge.

Charging Your Vehicle

AMBER	BLUE	RED	MODE	ACTION
OFF	OFF	OFF	UNPOWERED; The universal home charge cord is not powered.	Make sure the outlet is operational, and the circuit breaker is in the ON position or try using another outlet. Make sure the connector is fully inserted into the universal home charge cord. Make sure the plug is not severely degraded. If the error persists, contact us.
OFF	PULSING	OFF	CHARGING; The universal home charge cord is charging.	No action required.
OFF	ON	OFF	STANDBY; The universal home charge cord is powered and ready to charge. At the current time the universal home charge cord is not charging the vehicle.	If you expect the universal home charge cord to be charging the vehicle, make sure the vehicle coupler is properly inserted into the vehicle. Check and adjust your charging time preferences in the on screen display. If your vehicle is still not charging, contact us.

Charging Your Vehicle

AMBER	BLUE	RED	MODE	ACTION
ON	ON	ON	REBOOTING; The universal home charge cord is recovering after encountering an error.	Wait for the universal home charge cord to return to standby. If the universal home charge cord cycles for more than 2-3 minutes, unplug the vehicle coupler. Unplug and replug in the connector. If the issue persists, contact us.
ON	PULSING	OFF	CHARGING REDUCED; The universal home charge cord is charging at a reduced rate due to overheating.	Make sure the connector and the control box are properly connected. Unplug and replug in the connector. If the universal home charge cord is warm or in a hot environment, try charging in a cooler area. Try a different outlet. Try a different connector if you have one available. If the error persists, contact us.

Charging Your Vehicle

AMBER	BLUE	RED	MODE	ACTION
1 FLASH	PULSING	OFF	<p>CHARGING REDUCED, AC PLUG OR WALL OUTLET;</p> <p>The universal home charge cord is charging at a reduced rate due to over-heating of the connector or the wall outlet.</p>	<p>Make sure the connector and control box are properly connected. Unplug and replug in the connector. If the universal home charge cord is warm or in a hot environment, try charging in a cooler area. Try a different outlet. Try a different connector if you have one available. If the error persists, contact us.</p>
ON	OFF	OFF	<p>USER TROUBLESHOOTING</p> <p>The universal home charge cord has encountered a fault that requires troubleshooting.</p>	<p>Make sure the connector and control box are properly connected. Unplug and replug in the connector. If the universal home charge cord is warm or in a hot environment, try charging in a cooler area. Try a different outlet. Try a different connector if you have one available. If the error persists, contact us.</p>

Charging Your Vehicle

AMBER	BLUE	RED	MODE	ACTION
OFF	OFF	ON	NON - RECOVERABLE FAULT; There is an internal fault in the universal home charge cord that cannot be recovered.	Try a different connector if you have one available. If error persists, contact us.
OFF	OFF	1 FLASH	NON - RECOVERABLE FAULT; There is an internal fault in the connector that cannot be recovered.	Try using another connector if you have one available. If not, contact us about obtaining a replacement. If your warranty has expired, you can order a replacement from your Ford dealer.
OFF	OFF	PULSING	GROUND LEAKAGE FAULT; Electrical current is leaking through a potentially unsafe path.	Potential shock hazard - immediately turn off circuit breaker for the outlet within home. Discontinue use. Contact us about obtaining a replacement.

Note: When plugging into an unfamiliar wall outlet, let the vehicle charge for several minutes before leaving it unattended. The red indicator illuminates if it is not charging. The unit turns off if the breaker or infrastructure ground fault interrupter (GFCI) is tripped. You can view your vehicle charging status remotely via the Ford Pass app.

Universal Home Charge Cord Auto-Restart

Auto-restart helps make sure that your vehicle is charged and ready for use when needed. A charge could be interrupted if errors are detected. Charging resumes once the error is no longer detected. The red indicator illuminates during an error condition.

Charging Your Vehicle

The exception to the immediate auto-restart is when the interruption is due to a charger ground fault circuit interruption (GFCI) event. The charger attempts to restart 15 minutes after a (GFCI) event. After the fourth attempt to restart, the charger shuts down and the red indicator stays on.

If the fault persists, do not continue to try to charge your vehicle. Contact your authorized dealer.

MOVING AND STORAGE INSTRUCTIONS

Make sure you wrap the universal home charge cord after charging. Store the universal home charge cord in the storage bag supplied with the universal home charge cord when not in use.

When charging is complete, replace the universal home charge cord in the rear luggage compartment under the load floor.

Note: *Do not hold the universal home charge cord by the power cable. Hold the complete unit and carefully place back in the storage bag.*

Note: *To remove the connector, firmly grasp the connector by the cable or plug and pull away from the control box.*

CARE INSTRUCTIONS

Do not use cleaners or solvents as this could damage the universal home charge cord. Do not place stress on the charger cables. If the unit overheats, remove the universal home charge cord from direct sunlight.

SAFETY FEATURES

The charger includes the following safety features to protect against the risk of electric shock:

- Service ground check: The charger constantly checks for the presence of a service ground connection. If the service ground ever fails, the charger's red indicator illuminates and shuts down power to the vehicle.
- Thermal event sensor: Charger module senses out-of-ordinary thermal events and decreases charging current or shut the unit down if required.
- GFCI protection: The charger has a ground fault circuit interruption (GFCI) reaction system to protect against electric shock. If the charger module detects an output ground fault, it shuts down power to the output cable and the red indicator illuminates.
- Insulation: The charger module, connector, cable assembly, and charge coupler are completely insulated, no exposed live parts, to protect against electric shock.
- Unintentional disconnection: The charge coupler is designed to minimize unintentional disconnection. A pilot signal wire in the cable and charge coupler eliminates the possibility of electric shock when not connected to a vehicle or if an unintended disconnect occurs during a charge. Disconnection during charging is safe.

LOCATING THE CHARGE PORT

The charge port is between the front left-hand side door and front left-hand wheel well. To open, press the center right-hand edge of the charge port door and then release.

Charging Your Vehicle

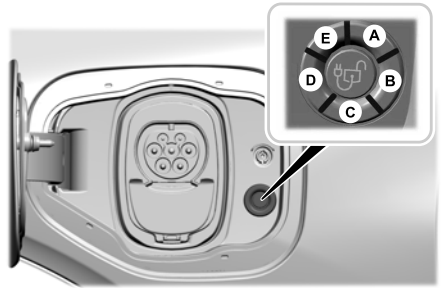
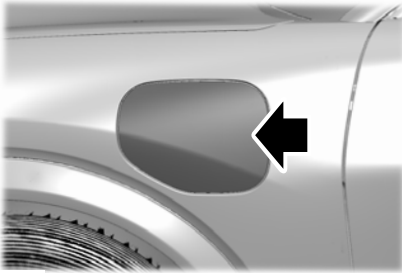

Note: Do not apply excessive force. Forcing the door open or closed damages the charge port.

CHARGE PORT INDICATORS

The charge status indicator is next to the charging port behind the charge port door. It indicates the charge status of the high voltage battery in your vehicle.

Divided into five zones, the charge status indicator displays the state of charge in 20 percent increments.

The charge status indicator displays how far along the charge is:

- When zone A is pulsing, the charge is between 0-20 percent.
- When zone A illuminates, and zone B is pulsing, the charge is between 20-40 percent.
- When zones A and B illuminate and zone C is pulsing, the charge is between 40-60 percent.
- When zones A, B, and C illuminate, and zone D is pulsing, the charge is between 60-80 percent.
- When zones A, B, C, and D illuminate, and zone E is pulsing, the charge is between 80-100 percent.
- When all zones illuminate, the charge is 100 percent.

Note: When charging stops, the charge status indicator shows all the completed zones solidly illuminated in a blue color for 30 seconds before turning off. For example, if charging stops at 70 percent, then A, B, and C light up solidly to indicate a battery charge level of at least 60 percent but less than 80 percent. Charging stops when complete or when paused due to charge settings or charge station actions.

Note: If the charge status indicator does not light up or pulse after plugging in, please verify that the charge port light setting is On. If you do not wish to have the charge status indicator light up at all while charging, then you can turn it Off. Locate the charge port light under the vehicle settings on your in-vehicle touchscreen.

There are three charge port indicator light colors, which indicate a specific action:

White is used as a courtesy light to help with plugging in and to acknowledge actions such as plugging in and unplugging.

Blue is used when the vehicle is plugged in and either charging or waiting to charge.

Amber is used to indicate charge faults.

Charging Your Vehicle



Note: Charging faults are identified by the color amber on the charge status indicator. Faults can occur within the vehicle charging system or outside the vehicle, such as with the universal home charge cord, charge station or electrical supply.

Note: If the system detects a fault in the vehicle charging system at any point in a charge cycle, the entire charge status indicator illuminates solidly in an amber color for 30 seconds and then turns off. If this happens, unplug the charge coupler and then plug it back into the charge port receptacle. If the problem persists, contact your dealer.

Note: If the system detects a fault outside the vehicle, such as with the charge station or universal home charge cord, the entire charge status indicator flashes amber continuously for 30 seconds and then turns off. If this happens check the universal home charge cord and the charge station or electrical supply.

AC CHARGING

CONNECTING THE CHARGER



Charging At Home

CAUTION: TO REDUCE THE RISK OF FIRE - The plug must be properly grounded. Use a dedicated circuit. If you do not use a dedicated circuit, the circuit breaker could trip or open. If you do not have a dedicated circuit, contact a licensed professional electrician for proper installation.

You must unwrap the universal home charge cord completely before charging.

When using the universal home charge cord, plug the charge coupler into the vehicle charge port where the same identifier symbol can be seen.

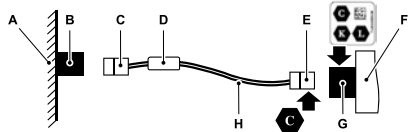

- A Mains.
- B Socket outlet (household).
- C Plug.
- D Control box.
- E Charge coupler.
- F Vehicle.
- G Charge port receptacle.
- H Universal home charge cord.

1. Put your vehicle in park (P).

Note: Your vehicle must be in park (P) to charge and for the charge status indicator to illuminate.

2. Press the center right edge of the charge port door and then release to open the door.
3. Select the appropriate connector for the wall outlet you will use and plug the connector into the universal home charge cord control box.

Note: To insert the connector, firmly grasp the connector by the cable or plug and push into the control box until it clicks. Make sure the connector is fully inserted and flush with the control box before inserting it into the outlet. Improper insertion will cause a longer charge session or faults.

4. Plug the connector into the wall outlet.
5. Confirm that the universal home charge cord's LEDs illuminate.

Charging Your Vehicle

6. Plug the charge coupler into the charge port receptacle on your vehicle.

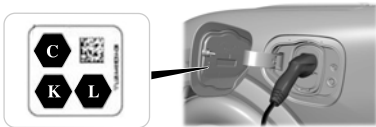

Note: Your vehicle will lock to the charge coupler.

Note: When you plug in your vehicle, it starts charging to 100% by default unless you set up scheduled charging for this location. See **Setting the Charging Schedule and Preferences** (page 180).

Note: Plug the connector into the wall outlet before connecting the charge coupler to your vehicle's charge port.

Note: When the handle is properly engaged the light ring will illuminate. This indicates the beginning of a normal charge cycle.

Note: There could be a delay in light ring illumination due to vehicle internal communications.

Note: If charging for your vehicle fails, please contact the Customer Relationship Center. To ensure superior service, please take note of the serial number when contacting customer support.

For more information, visit www.owner.ford.com.

Charging In Public

When using an AC charge station with cables attached, choose the charge station cord coupler where the same identifier symbol can be seen.

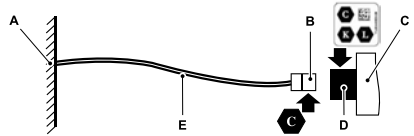

- A AC charge station.
- B Charge coupler.
- C Vehicle.
- D Charge port receptacle.
- E Cable.

1. Put your vehicle in park (P).

Note: Your vehicle must be in park (P) to charge.

2. Press the center right hand edge of the charge port door and then release to open the door.
3. Select the appropriate charge station coupler.
4. Plug the charge coupler into the charge port receptacle on your vehicle.



Charging Your Vehicle

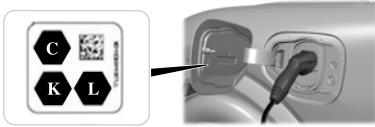

Note: Your vehicle will lock to the charge coupler.

Note: When you plug in your vehicle, it starts charging to 100% by default unless scheduled charging has been set up for this location. See **Setting the Charging Schedule and Preferences** (page 180).

Note: When the handle is properly engaged the light ring will illuminate. This indicates the beginning of a normal charge cycle.

Note: There could be a delay in light ring illumination due to vehicle internal communications.

Information about public charge stations, pricing, power levels and real time availability is available through the in-vehicle screen as well as the FordPass app. Rates for charging will vary by power level, provider, location, and time of day.

When charging your vehicle at a BlueOval Charge Network station, use the FordPass App to activate and pay for charging. You can also just plug in to activate charging at Plug & Charge capable stations. If the charging station is not in the BlueOval Charge Network, use the directions on the charge station to activate the charger.

For more information, visit www.owner.ford.com.

Charging Using Your Public Charge Cord

When using an AC charge station without cables attached, plug your public charge cord into the charge station and the vehicle charge port where the same identifier can be seen.

You must unwrap the public charge cord completely before charging.

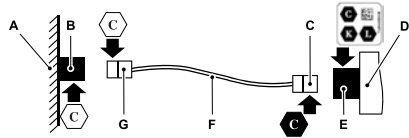

- A AC charge station.
- B Charge station port.
- C Vehicle charge coupler.
- D Vehicle.
- E Charge port receptacle.
- F Public charge cable.
- G Charge station charge coupler.

1. Put your vehicle in park (P).

Note: Your vehicle must be in park (P) to charge.

2. Press the center right hand edge of the charge port door and then release to open the door.
3. Select the appropriate charge station port.
4. Plug your public charge cord into the charge station port.

Note: To insert the coupler, firmly grasp the handle and push into the charge station port.

5. Plug the charge coupler into the charge port receptacle on your vehicle.

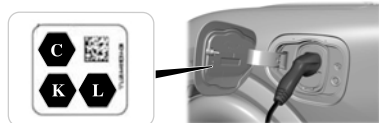

Note: Your vehicle will lock to the charge coupler.

Charging Your Vehicle

Note: When you plug in your vehicle, it will start charging to 100% by default unless scheduled charging has been set up for this location. See **Setting the Charging Schedule and Preferences** (page 180).

Note: When the handle is properly engaged the light ring will illuminate. This indicates the beginning of a normal charge cycle.

Note: There could be a delay in light ring illumination due to vehicle internal communications.

Information about public charge stations, pricing, power levels and real time availability is available through the in-vehicle screen as well as the FordPass app. Rates for charging will vary by power level, provider, location, and time of day.

When charging your vehicle at a BlueOval Charge Network station, use the FordPass App to activate and pay for charging. You can also just plug in to activate charging at Plug & Charge capable stations. If the charging station is not in the BlueOval Charge Network, use the directions on the charge station to activate the charger.

For more information, visit www.owner.ford.com.

STOPPING CHARGING



WARNING: To safely discontinue charging at any time, follow the disconnect instructions in stopping charging. Charging will automatically and safely come to a stop. The BLUE STATUS indicator remains ON solid when the coupler is removed.

Using the universal home charge cord:

1. Push the unlock button on the charge port and remove the charge coupler from your vehicle.



2. Remove the connector plug from the wall outlet.

Note: Do not attempt to remove the charge coupler before you unlock it. Do not use any kind of tool to try and remove a locked charge coupler. Doing so could damage your vehicle and the charge coupler.

Note: You can also unlock the cord through your vehicle touchscreen. If the cord still does not unlock, please contact roadside assistance or manually release the charge cord.

Note: If the charging equipment remains connected, the charge port relocks in a short period of time. Charging does not resume.

Note: Do not pull the wall plug from the wall or the connector from the universal home charge cord control box when your vehicle is charging. Doing so could damage the outlet and the cord.

Note: You cannot shift your vehicle out of park (P) until you remove the charge coupler.

Charging Your Vehicle

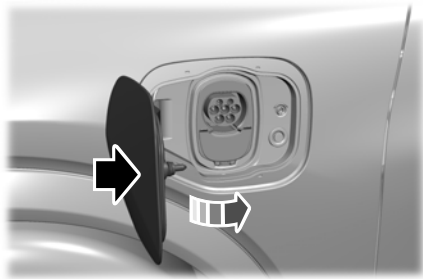

3. Press the center right-hand edge of the charge port door to close.

Charge Coupler Manual Release

If your vehicle does not unlock the charge coupler, you can manually release it.

See **Stopping Charging** (page 179).

DC CHARGING

CONNECTING THE CHARGER



To charge the high-voltage battery at a charge station:

When using the charge station with cables attached, choose the charge station cord coupler where the same identifier symbol can be seen.

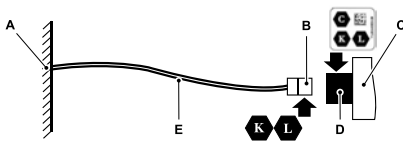

- A DC charging station.
- B Charge coupler.
- C Vehicle.

- D Charge port receptacle.
- E Cable.

1. Put your vehicle in park (P).

Note: Your vehicle must be in park (P) to charge and for the charge status indicator to illuminate.

2. Press the center right-hand edge of the charge port door and then release to open the door.
3. Open the dust cap cover on the charge port to expose lower connectors.

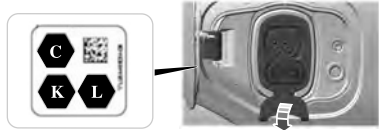

4. Plug the charge coupler into the charge port receptacle on your vehicle.



Note: Your vehicle will lock to the charge coupler.

Note: When the charge coupler is properly engaged, the light ring illuminates. This indicates the beginning of a normal charge cycle.

Charging Your Vehicle

Note: The vehicle monitors battery health and may take actions including, but not limited to, reducing the DC fast charge rate to protect the battery hardware from damage, and to maintain battery health.

Information about public charge stations, pricing, power levels and real time availability is available through the in-vehicle screen as well as the FordPass app. Rates for charging will vary by power level, provider, location, and time of day.

STOPPING CHARGING

1. Push the coupler unlock button on the light ring and remove the charge coupler handle from the vehicle.



2. Close the dust cap cover.

Note: Do not attempt to remove the charge coupler before you unlock it. Do not use any kind of tool to try and remove a locked charge coupler. Doing so could damage your vehicle and the charge coupler.

Note: You cannot unlock the charge coupler handle unless the vehicle remote is near the vehicle.

Note: You can also unlock the cord through your vehicle touchscreen. If the cord still does not unlock, please contact roadside assistance.

Note: If the charging equipment remains connected, the charge port relocks in a short period of time. Charging does not resume.

Note: You cannot shift your vehicle out of park (P) until you remove the charge coupler handle.

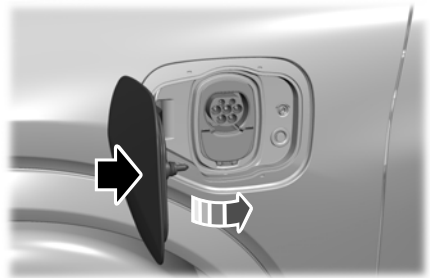

3. Press the center right-hand edge of the charge port door to close.

Charge Coupler Manual Release

If your vehicle does not unlock the charge coupler, you can manually release it.

Releasing the charge coupler:

1. Switch off your vehicle.
2. Open the hood.
3. Remove the inner luggage compartment shields and locate the low voltage service disconnect. See **Installing and Removing the Luggage Compartment Cover** (page 297).

Charging Your Vehicle

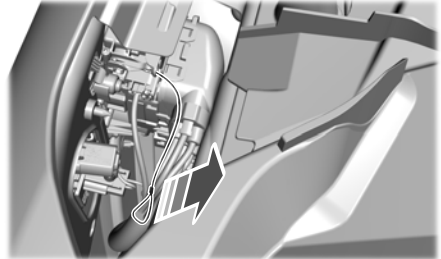
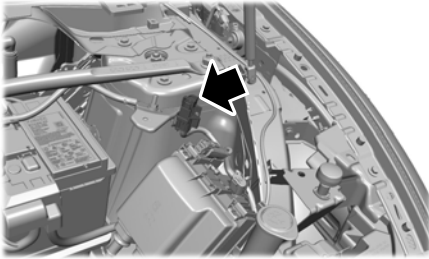

4. Move the low voltage service disconnect to the off position.

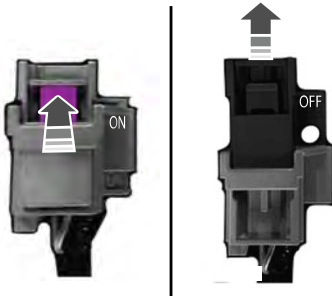

5. Locate the manual release mechanism.

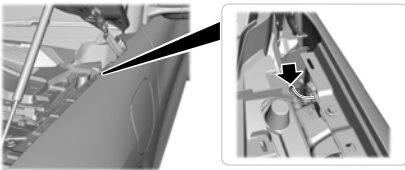

6. Between the gap of the hood and windshield, access the manual release mechanism and pull the pull ring firmly, perpendicularly toward the center of your vehicle. Once pulled, make sure you do not tangle the pull cord as it resets on the next charge session.

7. Remove the charge coupler from the charge port.
8. Close the low voltage service disconnect.
9. Reinstall the inner luggage compartment shields. See **Installing and Removing the Luggage Compartment Cover** (page 297).
10. Close the hood.

Note: The next time you plug in to charge your vehicle, the locking mechanism re-engages and the pull ring resets.

SETTING THE CHARGING SCHEDULE AND PREFERENCES

 You can schedule charging times to take advantage of lower-cost electricity rates during off-peak hours if you have signed up for a time of use pricing plan with your utility provider. You can also set an upper charge limit for your battery, a departure time, and cabin temperature so your vehicle is ready to go when you are.

Scheduled charging can be set up in the on vehicle display or in the FordPass app.

To view your charge settings:

Charging Your Vehicle

1.  Press the button on the touchscreen to open the application drawer.

2. Press **Charging**.

Charge Settings Screen



- A Charge status and indicator.
- B Estimated vehicle driving range.

- C Charging time information.
- D High voltage battery state of charge.
- E Departure and comfort.
- F Charging locations.

Charge Status

Shows the present state of the charging system.

Charge Status	Action
Will charge when plugged in	The vehicle is unplugged and will start charging once plugged in.
Will wait for preferred charging time	The vehicle is unplugged at a location with charging time preferences enabled. Charging is scheduled to start at the time displayed based on your settings. You must plug in prior to the start time shown for the vehicle to begin charging at that time.
Waiting for preferred charging time	The vehicle is plugged in at a location with charging time preferences enabled. Charging starts at the time displayed, which is based on your charge time settings.

Charging Your Vehicle

Charge Status	Action
Charging stopped	The vehicle is plugged in and charging has been stopped through the FordPass app.
Charging	The vehicle is plugged in and charging.
Fast charging	The vehicle is plugged into a DC Fast Charge station and charging.
Charged	The vehicle finished charging to the max charge limit setting.
Charging 12V battery	The vehicle is plugged in and charging the 12V battery.
Conditioning the cabin	The vehicle is plugged in and the climate control system is operating according to the departure and comfort settings.
Conditioning the battery	The vehicle is plugged in and conditioning the high voltage battery.
Vehicle charging fault	The vehicle is plugged in and there is a fault within the vehicle charging system. Unplug and plug back in. If the fault is still present, contact your authorized EV certified dealer.
Charge station fault	The vehicle is plugged in and a fault has been detected with the charge station or charging cord. Check the charging cord and the charging station or electrical supply.
Charge station not detected	A charging coupler has been plugged into the vehicle but there is no connection with a charging power source.
Charge station paused	The vehicle is plugged in and charging has been paused at the charge station.

Charge Status Indicator

Displays when your vehicle is plugged in.



Not charging due to a fault.



Not currently charging.



Charging.



Waiting to charge based on charge time settings.

Charging Your Vehicle

Charging Time Information

When charging, the start and estimated end time displays. When fast charging, the end time is replaced with the estimated time at 80% charge until the charge reaches 80%, then the estimated time at 100% charge is displayed.

When your vehicle is at a saved charging location and not plugged in, the start and end times display based on known charging infrastructure.

Note: *Charging time information is estimated. Certain conditions could result in longer charging times. See **Charging Your Vehicle** (page 161).*

High Voltage Battery State of Charge

Displays the remaining charge percentage with 100% representing the total amount of energy you can get from an external charge.

Estimated Vehicle Driving Range

Displays the estimated distance the vehicle can travel with the present high voltage battery charge level. See **Vehicle Range Display** (page 123).

Charging Locations



Press the edit button to set preferred charge times for a specific charging location.

Your vehicle prioritizes charging based on your preferred time settings. You can set two preferred charging time windows for weekdays and two for weekends. This feature allows you to take advantage of electric utility rate plans that offer lower pricing during certain times of day. Contact your utility company to see what plans are available.

Note: *Your vehicle will charge during your preferred time windows. Charging outside these windows only occurs when additional charging time is needed to reach the maximum charge level set for this location by your next departure time. In this case, the vehicle will typically begin charging right away after plugging in.*

Note: *You can also access this feature using the FordPass app.*

Departure and Comfort



Press the edit button for departure and comfort settings.

Setting departure times allows you to control charging schedules and warm or cool your cabin and the high voltage battery when your vehicle is plugged in, so your vehicle is ready to drive when you are. By setting a departure time, your vehicle can use your charge time settings to minimize your electricity costs but still prioritize finishing charging before your scheduled departure. The calendar view allows you to program two departure times per day for each day of the week.

Note: *By using energy from your charging source while plugged in, battery temperature can be managed for best driving performance and less energy will be needed for heating or cooling of the cabin at the start of your drive. This helps maximize your driving range.*

Note: *You can also access this feature using the FordPass app.*

Additional information and settings display on the charge settings screen once charging locations and departure and comfort have been set up.

Charging Your Vehicle



- A Charging location name.
- B Next departure time.
- C Cabin comfort level.

Charging Location Name

Displays when your vehicle is at a saved charging location.

Next Departure Time and Cabin Comfort Level

Displays the next departure time and associated cabin comfort setting.

On/Off Switch for Charging Locations

This switch is visible when your vehicle is at a saved charging location. Use this switch to turn your settings off and on for this location only. Switching off for this location does not delete your settings, however, you must switch this feature back on to re-enable them.

On/Off Switch for Departure and Comfort

This switch is visible when you have at least one departure time set. Use this switch to turn all departure times off and on. Switching off departure and comfort does not delete your settings, however, you must switch this feature back on to re-enable them.

Charging Location Setup

Follow these steps to set time and charge level preferences for a charging location.



Press the edit button for charging locations on the charge settings screen.

1. Select an address from the list of recent charge locations. If the previously saved charge locations are not listed, then you must first select add new location. You can also edit settings for previously saved locations.
2. Confirm that this is the location you want to save with the help of the map view. Edit the location name if desired and set a maximum charge level. Press next.

Note: *Charging will stop when your vehicle reaches the maximum charge level setting.*



Charging Your Vehicle

3. Set preferred charging times for weekday and/or weekend by pressing and dragging along the 24 hour time wheel. You can set up to two blocks of time (charge windows). Press next once you have your desired time settings for weekday and weekend.

Note: *Selecting all or none of the 24 hours results in any time of day given equal priority for charging.*

4. The summary screen displays your settings for this location. Press save or press the left arrow to go back and change your settings. Whenever your vehicle is at a saved charging location, the charge settings screen displays the location name, and the charging times are based on your preferred time settings for that location plus the next departure time.

Note: *Reaching your max charge level by your next departure time is always the priority. When charge times are set, charging outside your preferred charging time windows could be necessary in order to finish by your next departure time. In this case, the vehicle will typically begin charging right away after plugging in.*

Departure and Comfort Setup

Follow these steps to set departure times and cabin comfort level.

1. Press the edit button for departure and comfort on the charge settings screen.
2. Select a time for each day of the week you want your settings to apply. Select the hour and minutes as well as your desired comfort level. Your selected days/times now display your departure and comfort settings. Press Save to apply your settings. The next departure display on the charge settings screen will update appropriately.

Note: *Save your departure settings before selecting additional days/times. The process must be repeated to add additional unique departure times and comfort levels.*

Note: *Cabin conditioning comfort level may vary depending on if you plug into a normal household outlet or a higher power outlet or charging station. The power available for conditioning is limited to the charging station power available. At low ambient temperatures and low charge power, a small amount of high voltage battery power in addition to the charging power could be used to heat the cabin.*

Note: *The departure and comfort settings can also be accessed through the separate vehicle settings departure and comfort button. Press the edit button from this screen to begin the settings process outlined above.*

USING FORDPASS AND CHARGING

The FordPass App allows you to do the following:

- Monitor and manage your vehicle's charging, including charge schedules and preferences.
- Locate a charger and activate a charger on the BlueOval Charge Network.
- Plan a trip and charging options along your route.
- Check charging station plug availability.
- Initiate a charge session automatically at Plug and Charge capable charge stations.
- Control your Ford Connected Charge Station remotely.
- Override charge preferences and starting and stopping charging.

For more information, visit www.owner.ford.com.

Charging Your Vehicle

CHARGING YOUR VEHICLE HINTS

Use AC charging when possible and minimize the use of DC charging. It helps to preserve your high voltage battery's efficiency and lifespan.

We recommend ending DC charges at 80% state of charge.

Note: *The system could reduce DC fast charging rate to preserve the battery. This is based on battery temperature, battery state of charge and battery health.*

In cold temperatures, you may notice that DC charging takes longer when the ambient temperature drops below 10°C (50°F). Shutting off climate control or reducing climate control temperature and fan settings for the first 10 to 15 minutes of DC charging allows the battery to warm up and improve the charging rate.

Note: *When the temperature is below freezing, fully turning off cabin heat for the first 10 to 15 minutes of DC charging could significantly improve the charging rate.*

When AC charging, keep your vehicle plugged in when outside temperatures are very high or low. This enables the system to maintain the high voltage battery for best performance.

CHARGING EQUIPMENT IDENTIFICATION SYMBOLS



Identifier symbol visible on vehicle cord couplers, charge station cord couplers and vehicle charge ports.

Supply Type	Standard	Configuration	Type of Accessory	Voltage Range
AC	EN 62196-2	Type 2	Vehicle coupler, charge station coupler and vehicle charge port.	Lower or equal to 480 volt RMS



Identifier symbol visible on charge station ports and your public charge cord coupler.

Supply Type	Standard	Configuration	Type of Accessory	Voltage Range
AC	EN 62196-2	Type 2	Charge station port, public charge cord coupler.	Lower or equal to 480 volt RMS

Charging Your Vehicle



Charge station coupler identifier symbol.

Supply Type	Standard	Configuration	Type of Accessory	Voltage Range
DC	EN 62196-3	FF	Vehicle coupler, vehicle charge port, and charge station coupler.	50 volt to 500 volt



Charge station coupler identifier symbol.

Supply Type	Standard	Configuration	Type of Accessory	Voltage Range
DC	EN 62196-3	FF	Vehicle coupler, vehicle charge port, and charge station coupler.	200 volt to 920 volt

CHARGING YOUR VEHICLE – TROUBLESHOOTING

CHARGING YOUR VEHICLE – WARNING LAMPS



It illuminates when your vehicle is plugged in.

Charging Your Vehicle

CHARGING YOUR VEHICLE – INFORMATION MESSAGES

Message	Action
Vehicle plugged in? Yes No	Your vehicle needs confirmation you unplugged it before allowing a start. You must make sure you unplugged your vehicle and you respond to the message prompt before starting your vehicle.
Plug in to Maintain 12V Battery	Indicates that the high voltage battery can no longer support the 12 volt battery due to its low range. Plug in your vehicle to charge the high voltage battery and maintain the 12 volt battery at a healthy state.
Charge Station Fault See Manual	Your plugged in vehicle detects a fault with the charge station or charging cord. Please check the charging cord and the charging station or electrical supply.
Charge Station Commu- nication Error Contact Station Provider	Your plugged in vehicle cannot communicate with the charging station. Please contact the station provider.

Charging Your Vehicle

CHARGING YOUR VEHICLE – FREQUENTLY ASKED QUESTIONS

My vehicle does not charge

Ensure you properly connect the connector and control box. Unplug the charge coupler from your vehicle and unplug the connector from the wall outlet. Then check the connector to be sure that the connector is properly connected into the mobile charger control box. If the mobile charger is warm, or in a hot environment, try charging in a cooler area. Try a different outlet or a different connector if you have one available. If the problem persists, contact an authorized EV certified dealer.

Electric Motor

ELECTRIC MOTOR PRECAUTIONS

 **WARNING:** When your vehicle is stationary, keep the brake pedal fully pressed when shifting gears. Failure to follow this instruction could result in personal injury, death or property damage.

 **WARNING:** Do not apply the brake pedal and accelerator pedal simultaneously. Applying both pedals simultaneously for more than a few seconds will limit power, which may result in difficulty maintaining speed in traffic and could lead to serious injury.

 **WARNING:** Apply the parking brake, shift into park (P), switch the vehicle off and remove the key or remote control before you leave your vehicle. Failure to follow this instruction could result in personal injury or death.

Note: *You may not be able to shift out of park (P) unless the intelligent access key is inside your vehicle.*

SELECTOR POSITIONS

PARK (P)

 **WARNING:** Shift into park (P) only when your vehicle is stationary.

In park (P) power is not transmitted to the driven wheels.

Note: *A tone sounds if you attempt to exit your vehicle without the selector in park (P).*

Note: *Your vehicle may not shift out of park (P) if the vehicle battery has run out of charge. See **Jump Starting the Vehicle** (page 314).*

Note: *Your vehicle may not shift out of park (P) if a fuse is blown. See **Fuses** (page 320).*

Note: *The electronic parking brake could apply when the selector is in park (P). See **Automatically Releasing the Electric Parking Brake** (page 198).*

Note: *Your vehicle could shift into park (P) if you attempt to exit your vehicle without the selector in park (P). See **How Does Automatic Return to Park (P) Work** (page 192).*

Note: *A tone could sound when you select park (P).*

REVERSE (R)

 **WARNING:** Shift into reverse (R) only when your vehicle is stationary.

In reverse (R) power is transmitted to the driven wheels.

NEUTRAL (N)

 **WARNING:** In neutral (N) your vehicle is free to roll.

In neutral (N) power is not transmitted to the driven wheels.

DRIVE (D)

In drive (D) power is transmitted to the driven wheels.

Electric Motor

LOW (L)

In low (L) your vehicle decelerates more noticeably than in drive (D) when you release the accelerator pedal.

Note: We recommend using this mode for driving on hilly or mountainous roads or when towing a trailer. See **Towing a Trailer** (page 303).

SHIFTING YOUR VEHICLE INTO GEAR

The selector is on the center console.



1. Press and hold the brake pedal.
2. Rotate the outer ring to select a position.

Note: The position illuminates on the selector.

Note: Your vehicle cannot shift from drive (D) to park (P) with a clockwise rotation. Your vehicle cannot shift from park (P) to drive (D) with a counterclockwise rotation.

3. Press the low (L) button when your vehicle is in drive (D) to enter or exit mode.

TEMPORARY NEUTRAL MODE

WHAT IS TEMPORARY NEUTRAL MODE

This mode keeps your vehicle in neutral (N), for a limited time, when you exit your vehicle or switch your vehicle off.

Note: Do not tow your vehicle in this mode.

HOW DOES TEMPORARY NEUTRAL MODE WORK

Use this mode to keep your vehicle in neutral (N) when you exit your vehicle or switch your vehicle off. For example, if you exit your vehicle before an automatic car wash.

Note: You do not need to use this mode at an automatic car wash if you stay in your vehicle with power on.

Note: Do not tow your vehicle in this mode.

Note: Automatic return to park (P) is delayed when your vehicle is in this mode. See **What Is Automatic Return to Park (P)** (page 192).

TEMPORARY NEUTRAL MODE LIMITATIONS

Your vehicle could shift to park (P) after 30 minutes, or when the vehicle battery charge level is low. Prolonged use of this mode can cause the vehicle battery to run out of charge.

Do not tow your vehicle in this mode. Failure to follow these instructions could result in vehicle damage not covered by the vehicle warranty.

ENTERING TEMPORARY NEUTRAL MODE

1. Power your vehicle on.

Electric Motor

2. Bring your vehicle to a complete stop.
3. Press and hold the brake pedal.
4. Shift into neutral (N).

Note: *An instructional message appears.*

5. Press the low (L) button.

Note: *A confirmation message appears when your vehicle enters the mode.*

6. Release the brake pedal.

Note: *Your vehicle is free to roll.*

7. Switch your vehicle off.

Note: *Do not tow your vehicle in this mode.*

Note: *The neutral (N) indicator on the selector may flash in this mode.*

EXITING TEMPORARY NEUTRAL MODE

1. Press the brake pedal.
2. Shift into park (P), or power your vehicle on and shift into drive (D) or reverse (R).

AUTOMATIC RETURN TO PARK (P)

WHAT IS AUTOMATIC RETURN TO PARK (P)

Your vehicle shifts into park (P) if you attempt to exit your vehicle without the vehicle in park (P).

HOW DOES AUTOMATIC RETURN TO PARK (P) WORK

Your vehicle shifts to park (P) when your vehicle is stationary and any of the following occur:

- You switch the vehicle off.
- You open the driver door with the driver seatbelt unfastened.
- You unfasten the driver seatbelt with the driver door open.

Note: *Do not use automatic return to park (P) when your vehicle is moving, except in an emergency. See **Powering Off** (page 156).*

AUTOMATIC RETURN TO PARK (P) LIMITATIONS

Automatic return to park (P) may not work if the door ajar sensor or seatbelt sensor are malfunctioning.

See an authorized dealer if any of the following occur:

- Seatbelt indicator illuminates or tone sounds with the seatbelt fastened.
- Door ajar indicator does not illuminate with the driver door open.
- Door ajar indicator illuminates with the driver door closed.
- Transmission not in park message appears with the driver door closed, after you shift out of park (P).

ELECTRIC MOTOR AUDIBLE WARNINGS

Vehicle Not In Park (P) Audible Warning

Sounds if you open the driver door before shifting into park (P).

Electric Motor

Park Selection Audible Warning

Sounds when you shift into park (P).

All-Wheel Drive (If Equipped)

HOW DOES ALL-WHEEL DRIVE WORK

The all-wheel drive system is designed to continuously monitor and adjust power delivery to the front and rear wheels to optimize both traction and handling.

There is further information on driving in unique driving conditions. See **Driving Hints** (page 307).

ALL-WHEEL DRIVE PRECAUTIONS



WARNING: Do not become overconfident in the ability of all-wheel drive vehicles. Although an all-wheel drive vehicle may accelerate better than a two-wheel drive vehicle in low traction situations, it won't stop any faster than two-wheel drive vehicles. Always drive at a safe speed.

ALL-WHEEL DRIVE LIMITATIONS

The all-wheel drive system is not intended for use with mismatched tires.

Different tire sizes between the front and rear axles can cause system damage.

ALL-WHEEL DRIVE – TROUBLESHOOTING

ALL-WHEEL DRIVE – INFORMATION MESSAGES

Message	Action
AWD Temporarily Disabled	The all-wheel drive system temporarily turns off to protect itself from overheating.
AWD Off	The all-wheel drive system is not operating properly. If the warning stays on or continues to come on, contact an authorized dealer.
AWD Restored	The all-wheel drive system will resume normal function.

Brakes

BRAKE PRECAUTIONS

Wet brakes result in reduced braking efficiency. Gently press the brake pedal a few times when leaving a car wash or driving from standing water to dry the brakes.

Note: *Depending on applicable laws and regulations in the country where your vehicle was originally built, the stoplamps could flash during heavy braking. The hazard warning flashers could also turn on when your vehicle comes to a stop.*

ANTI-LOCK BRAKING SYSTEM

ANTI-LOCK BRAKING SYSTEM LIMITATIONS

The anti-lock braking system does not eliminate the risk of a crash when:

- You drive too close to the vehicle in front of you.
- Your vehicle is hydroplaning.
- You take corners too fast.
- The road surface is poor.

BRAKE OVER ACCELERATOR

If your accelerator pedal becomes stuck or trapped:

- Apply steady and firm pressure to the brake pedal to slow the vehicle and reduce power.
- Bring your vehicle to a complete stop and place it in park (P).
- Switch the power off.
- Apply the parking brake.

Inspect the accelerator pedal for any interference. If none are found and the condition persists, have your vehicle checked as soon as possible. If your vehicle has to be towed, we recommend that you contact a professional towing service.

LOCATING THE BRAKE FLUID RESERVOIR

See **Under Hood Overview** (page 331).

CHECKING THE BRAKE FLUID



WARNING: Do not use any fluid other than the recommended brake fluid as this will reduce brake efficiency. Use of incorrect fluid could result in the loss of vehicle control, serious personal injury or death.



WARNING: Only use brake fluid from a sealed container. Contamination with dirt, water, petroleum products or other materials may result in brake system damage or failure. Failure to adhere to this warning could result in the loss of vehicle control, serious personal injury or death.



WARNING: Do not allow the fluid to touch your skin or eyes. If this happens, rinse the affected areas immediately with plenty of water and contact your physician.



WARNING: The brake system could be affected if the brake fluid level is below the **MIN** mark or above the **MAX** mark on the brake fluid reservoir.

Brakes



1. Park your vehicle on a level surface.
2. Look at the brake fluid reservoir to see where the brake fluid level is relative to the **MIN** and the **MAX** marks on the reservoir.

Note: To avoid fluid contamination, the reservoir cap must remain in place and fully tight, unless you are adding fluid.

Only use fluid that meets our specifications. See **Capacities and Specifications** (page 359).

BRAKE FLUID SPECIFICATION

See **Brake Fluid Specification** (page 362).

BRAKES – TROUBLESHOOTING

BRAKES – WARNING LAMPS



WARNING: Driving your vehicle with the warning lamp on is dangerous. A significant decrease in braking performance may occur. It may take you longer to stop your vehicle. Have your vehicle checked as soon as possible. Driving extended distances with the parking brake engaged can cause brake failure and the risk of personal injury.



If the ABS indicator illuminates when you are driving, this indicates a malfunction. Your vehicle continues to have normal braking without the anti-lock braking system function. See an authorized dealer.

It also momentarily illuminates when you switch the ignition on to confirm the lamp is functional. If it does not illuminate when you switch the ignition on, or begins to flash at any time, have the system checked by an authorized dealer.

BRAKE



The brake indicator momentarily illuminates when you switch the ignition on to confirm the lamp is functional. It may also illuminate when you apply the parking brake and the ignition is on. If it illuminates when your vehicle is moving, make sure the parking brake is disengaged. If the parking brake is disengaged, this indicates low brake fluid level or a brake system fault. See an authorized dealer.

BRAKES – FREQUENTLY ASKED QUESTIONS

Occasional brake noise is normal. If a metal-to-metal, continuous grinding or continuous squeal sound is present, the brake linings could be worn-out. Have the system checked by an authorized dealer.

Note: *Brake dust could accumulate on the wheels, even under normal driving conditions. Some dust is inevitable as the brakes wear, and does not contribute to brake noise. See **Cleaning Wheels** (page 336).*

Note: *Depending on applicable laws and regulations in the country for which your vehicle was originally built, your brake lamps could flash during heavy braking. Following this, your hazard lights could also flash when your vehicle comes to a stop.*

Electric Parking Brake

WHAT IS THE ELECTRIC PARKING BRAKE

The electric parking brake is used to hold your vehicle on slopes and flat roads.

APPLYING THE ELECTRIC PARKING BRAKE



WARNING: Apply the parking brake, shift into park (P), switch the ignition off and remove the key before you leave your vehicle. Failure to follow this instruction could result in personal injury or death.



WARNING: If you drive extended distances with the parking brake applied, you could cause damage to the brake system.



WARNING: The electric parking brake does not operate if the vehicle battery has run out of charge.



The electronic parking brake switch is on the center console.

Pull the switch up to apply the electric parking brake. The red warning lamp flashes, then steadily illuminates when the parking brake is applied.

Note: You can apply the electric parking brake when the ignition is off.

Note: The electric parking brake could automatically apply when you shift into park (P). See **Park (P)** (page 190).

APPLYING THE ELECTRIC PARKING BRAKE IN AN EMERGENCY

You can use the electric parking brake to slow or stop your vehicle in an emergency. Pull the switch up and hold it.

The red warning lamp illuminates, a tone sounds and the stoplamps turn on when you use the electric parking brake in an emergency.

The electric parking brake continues to slow your vehicle down unless you release the switch.

Note: Do not apply the electric parking brake when your vehicle is moving, except in an emergency. If you repeatedly use the electric parking brake to slow or stop your vehicle, you could cause damage to the brake system.

MANUALLY RELEASING THE ELECTRIC PARKING BRAKE

1. Switch the power on.
2. Press and hold the brake pedal.
3. Push the switch down.

The red warning lamp turns off.

AUTOMATICALLY RELEASING THE ELECTRIC PARKING BRAKE

1. Close the driver door.
2. Shift into gear.
3. Press the accelerator pedal and pull away in a normal manner.

Electric Parking Brake

ELECTRIC PARKING BRAKE AUDIBLE WARNING

Sounds when the parking brake is on and your vehicle is moving. If the warning tone continues after you have released the parking brake, this indicates a malfunction. Have your vehicle checked as soon as possible.

RELEASING THE ELECTRIC PARKING BRAKE IF THE VEHICLE BATTERY HAS RUN OUT OF CHARGE

See **Jump Starting the Vehicle** (page 314).

See **Jump Starting the Vehicle** (page 314).

ELECTRIC PARKING BRAKE – TROUBLESHOOTING

ELECTRIC PARKING BRAKE – WARNING LAMPS

Brake System

 It illuminates red when you apply the parking brake and your vehicle is on. If the lamp flashes when the parking brake has been released, this indicates the parking brake system requires service. Have your vehicle checked as soon as possible.

Note: *Lamps may vary depending on region.*

Electric Parking Brake

 When the lamp illuminates yellow, it indicates a malfunction in the electric parking brake. Have your vehicle checked as soon as possible.

Note: *Lamps may vary depending on region.*

Electric Parking Brake

ELECTRIC PARKING BRAKE – INFORMATION MESSAGES

Park Brake

Message	Action
Park brake applied	The electric parking brake is set, the engine is running and you drive your vehicle more than 5 km/h (3 mph). If the warning stays on after the electric parking brake is released, have the system checked as soon as possible.
Park brake Press brake and switch to release	The electric parking brake is set and a manual release is attempted without the brake pedal being pressed.
Park brake Use switch to release	The electric parking brake is set and an automatic release is attempted but cannot be performed. Perform a manual release.
Release park brake	The electric parking brake is set and your vehicle speed exceeds 5 km/h (3 mph). Release the electric parking brake before continuing to drive.
Park brake not applied	The electric parking brake is not fully applied.
Park Brake not released	The electric parking brake is not fully released.
Brake maintenance mode	The electric parking brake system has been put into a special mode to allow brake service. Have the system checked as soon as possible.
Park brake Limited function Service required	The electric parking brake system has detected a condition that requires service. Some functionality may still be available. Have the system checked as soon as possible.
Park brake malfunction Service now	The electric parking brake system has detected a condition that requires service. Have the system checked as soon as possible.
Park brake System overheated	Numerous electric parking brake applies have overheated the system. Wait 2 minutes before attempting to apply again.

Reverse Brake Assist

WHAT IS REVERSE BRAKE ASSIST

Reverse brake assist is designed to reduce impact damage or assist in avoiding a collision while in reverse (R). Using sensors on the rear of the vehicle, it can detect a possible collision and apply the brakes. If full braking occurs, the system attempts to stop the vehicle a safe distance from the obstacle.

HOW DOES REVERSE BRAKE ASSIST WORK

Reverse brake assist functions when in reverse (R) and traveling at a speed of 2–12 km/h (1–7 mph).

If the system detects an obstacle behind your vehicle, it provides a warning through the rear parking aid or cross traffic alert system.

REVERSE BRAKE ASSIST PRECAUTIONS



WARNING: You are responsible for controlling your vehicle at all times. The system is designed to be an aid and does not relieve you of your responsibility to drive with due care and attention. Failure to follow this instruction could result in the loss of control of your vehicle, personal injury or death.



WARNING: To help avoid personal injury, always use caution when in reverse (R) and when using the sensing system.



WARNING: The system may not operate properly during severe weather conditions, for example snow, ice, heavy rain and spray. Always drive with due care and attention. Failure to take care may result in a crash.



WARNING: Traffic control systems, fluorescent lamps, inclement weather, air brakes, external motors and fans may affect the correct operation of the sensing system. This may cause reduced performance or false alerts.



WARNING: Some situations and objects prevent hazard detection. For example low or direct sunlight, inclement weather, unconventional vehicle types, and pedestrians. Apply the brakes when necessary. Failure to follow this instruction could result in the loss of control of your vehicle, personal injury or death.



WARNING: Do not use the system with accessories that extend beyond the front or rear of your vehicle, for example a trailer hitch or bike rack. The system is not able to make corrections for the additional length of the accessories.

The system only applies the brakes for a short period of time when an event occurs. Act as soon as you notice the brakes apply to remain in control of the vehicle. If you do not intervene the vehicle may start to move again.

Note: *Certain add-on devices around the bumper or fascia may create false alerts. For example, large trailer hitches, bicycle or surfboard racks, license plate brackets, bumper covers or any other device that may block the normal detection zone of the system. Remove the add-on device to prevent false alerts.*

Reverse Brake Assist

Note: The system does not react to small or moving objects, particularly those close to the ground.

Note: The system does not operate during hard acceleration or steering.

Note: If your vehicle sustains damage to the bumper or fascia leaving it misaligned or bent, it could alter the sensing zone causing inaccurate measurement of obstacles or false alerts.

Note: Vehicle loading and suspension changes can impact the angle of the sensors and may change the normal detection zone of the system resulting in inaccurate measurement of obstacles or false alerts.

Note: When you connect a trailer, the system may detect the trailer and provide an alert, or the system turns off. If the system does not turn off, manually switch the system off after you connect the trailer.

Note: You may experience reduced system performance on road surfaces that limit deceleration. For example, roads with ice, loose gravel, mud or sand.

SWITCHING REVERSE BRAKE ASSIST ON AND OFF

1.  Press the button on the touchscreen.

2. Press **Driver Assistance**.
3. Switch **Reverse Brake Assist** on or off.

Note: The system is unavailable when the rear parking aid, cross traffic alert or traction control is off.

Note: If your vehicle is not equipped with cross traffic alert the reverse braking assist relies on input from the rear parking aid and rear camera sensors.

Note: The default setting is on in some regions.

OVERRIDING REVERSE BRAKE ASSIST

There could be instances when unexpected or unwanted braking occurs. Firmly pressing the accelerator pedal or switching the feature off overrides the system.

REVERSE BRAKE ASSIST INDICATORS

If the system determines that a collision with an obstacle may occur, full braking may apply.



A message and warning indicator appear when the system applies the brakes.

Reverse Brake Assist

REVERSE BRAKE ASSIST – TROUBLESHOOTING

REVERSE BRAKE ASSIST – INFORMATION MESSAGES

Message	Description
Reverse Brake Assist	Displays when the system applies the brakes and remains on for a few seconds.
Reverse Brake Assist not available See manual	Make sure that all doors, liftgate or tailgate and hood are closed. Drive the vehicle on a straight road for a short period. Make sure the parking aids and cross traffic alert systems are on. If the message remains on, have the system checked as soon as possible.
Reverse Brake Assist malfunction	Displays when a system error has occurred. Have your vehicle checked as soon as possible.
Reverse Brake Assist off	Displays when reverse brake assist is off.

Reverse Brake Assist

REVERSE BRAKE ASSIST – FREQUENTLY ASKED QUESTIONS

Why is reverse brake assist unavailable?

- Make sure the reverse brake assist is on. See **Switching Reverse Brake Assist On and Off** (page 202).
- Make sure that all doors, liftgate or tailgate and hood are closed. Drive the vehicle on a straight road for a short period. If the message remains, have the system checked.
- If your vehicle has the cross traffic alert system, make sure it is on. See **Switching Cross Traffic Alert On and Off** (page 275).
- Make sure the rear parking aid system is on. See **Parking Aids** (page 219).
- Make sure the traction control is on. See **Switching Traction Control On and Off** (page 211).
- Your vehicle may have sustained a rear end impact. Have the sensors checked for proper coverage and operation.
- An anti-lock brake, traction control or stability control event may have occurred. Reverse brake assist resumes operation when the event is complete.
- Make sure the rear view camera and 360 degree camera are not dirty or obstructed. If dirty, clean the camera. If the message still appears after cleaning the camera, wait a short time for the message to clear. If the message does not clear, have the system checked.

- Make sure the cross traffic alert, rear parking aid and side parking aid sensors are not blocked or faulty. See **Locating the Cross Traffic Alert Sensors** (page 276). See **Locating the Rear Parking Aid Sensors** (page 220). See **Locating the Side Parking Aid Sensors** (page 222).
- You recently had your vehicle serviced, or the battery disconnected. Drive your vehicle a short distance to resume system operation.
- Reverse brake assist does not function when you connect a trailer. Operation resumes when you disconnect the trailer.

Note: *If the answers to why the system is unavailable do not assist in returning reverse brake assist to available, have the system checked as soon as possible.*

Cross Traffic Braking

WHAT IS CROSS TRAFFIC BRAKING

The system is designed to reduce impact damage or assist in avoiding a collision by using the sensors on the rear of your vehicle to detect a possible collision and applying the brakes.

HOW DOES CROSS TRAFFIC BRAKING WORK

The system only reacts for vehicles approaching from the sides when you shift into reverse (R).

If the system detects a vehicle approaching your vehicle, it provides a warning through the cross traffic alert system. See **What Is Cross Traffic Alert** (page 275).

The system only applies the brakes for a short period of time when an event occurs. Take action as soon as you notice the system applying the brakes in order to remain in control of your vehicle, the system does not do this for you.

Note: You need to enable cross traffic alert for the system to function.

CROSS TRAFFIC BRAKING PRECAUTIONS



WARNING: You are responsible for controlling your vehicle at all times. The system is designed to be an aid and does not relieve you of your responsibility to drive with due care and attention. Failure to follow this instruction could result in the loss of control of your vehicle, personal injury or death.



WARNING: To help avoid personal injury, always use caution when in reverse (R) and when using the sensing system.



WARNING: The system may not operate properly during severe weather conditions, for example snow, ice, heavy rain and spray. Always drive with due care and attention. Failure to take care may result in a crash.



WARNING: Do not use the system with accessories that extend beyond the front or rear of your vehicle, for example a trailer hitch or bike rack. The system is not able to make corrections for the additional length of the accessories.



WARNING: Some situations and objects prevent hazard detection, for example, inclement weather, unconventional vehicle types and pedestrians. Apply the brakes when necessary. Failure to follow this instruction could result in the loss of control of your vehicle, personal injury or death.

Note: If your vehicle sustains damage to the bumper or fascia leaving it misaligned or bent, it could alter the sensing zone causing inaccurate measurement of obstacles or false alerts.

Note: Vehicle loading and suspension changes can impact the angle of the sensors and may change the normal detection zone of the system resulting in inaccurate measurement of obstacles or false alerts.

Note: When you connect a trailer, the system may detect the trailer and provide an alert, or the system turns off. If the system does not turn off, switch the system off manually after you connect the trailer.

Cross Traffic Braking

Note: You may experience reduced system performance on road surfaces that limit deceleration. For example, roads with ice, loose gravel, mud or sand.

SWITCHING CROSS TRAFFIC BRAKING ON AND OFF

-  Press the button on the touchscreen.
- Press **Driver Assistance**.
- Switch **Cross Traffic Braking** on or off.

OVERRIDING CROSS TRAFFIC BRAKING

There could be instances when unexpected or unwanted braking occurs. Firmly pressing the accelerator pedal or switching the feature off overrides the system.

CROSS TRAFFIC BRAKING INDICATORS

If the system determines that a collision with an obstacle may occur, full braking may apply. Bring your vehicle to a stop a safe distance away from the obstacle.



A message and warning indicator appear when the system applies the brakes.

CROSS TRAFFIC BRAKING – TROUBLESHOOTING

CROSS TRAFFIC BRAKING – INFORMATION MESSAGES

Message	Action
Reverse Brake Assist not available See manual	Drive the vehicle on a straight road for a short period. Make sure the parking aids and cross traffic alert systems are on. If the message remains on, have the system checked as soon as possible.
Reverse Brake Assist malfunction	Displays when a system error has occurred. Have your vehicle checked as soon as possible.
Reverse Brake Assist off	Displays when cross traffic braking is off.

Cross Traffic Braking

CROSS TRAFFIC BRAKING – FREQUENTLY ASKED QUESTIONS

Why is cross traffic braking unavailable?

- Make sure the cross traffic alert system is on. See **Cross Traffic Alert** (page 275).
- The vehicle has sustained a rear end impact. Contact an authorized dealer to have the sensors checked for proper coverage and operation.
- An ABS, traction control or stability control event may have occurred. Cross traffic braking resumes operation when the event is complete.
- Make sure there are no blocked or faulted sensors. See **Cross Traffic Alert** (page 275).
- You recently had your vehicle serviced, or the battery disconnected. Drive your vehicle a short distance to resume system operation.

Note: *If the answers to why the system is unavailable do not assist in returning cross traffic braking to available, have the system checked as soon as possible.*

Hill Start Assist

WHAT IS HILL START ASSIST

Hill Start Assist makes it easier for you to pull away when your vehicle is on a slope without using the parking brake.

HOW DOES HILL START ASSIST WORK

When the system activates, your vehicle remains stationary for a few seconds after you release the brake pedal. This gives you time to move your foot from the brake pedal to the accelerator pedal. The brakes release when you apply the accelerator pedal and the vehicle begins to move forward, or the vehicle is stationary beyond the hill start assist hold time.

HILL START ASSIST PRECAUTIONS



WARNING: The system does not replace the parking brake. When you leave your vehicle, always apply the parking brake.



WARNING: You must remain in your vehicle when the system turns on. At all times, you are responsible for controlling your vehicle, supervising the system and intervening, if required. Failure to take care may result in the loss of control of your vehicle, serious personal injury or death.



WARNING: The system turns off if there is a malfunction.

Auto Hold

HOW DOES AUTO HOLD WORK

Auto hold applies the brakes to hold your vehicle after you bring the vehicle to a stop. This can help when waiting on a hill or in traffic.

SWITCHING AUTO HOLD ON AND OFF



WARNING: The system does not replace the parking brake. When you leave your vehicle, always apply the parking brake.



WARNING: You must remain in your vehicle when the system turns on. At all times you are responsible for controlling your vehicle, supervising the system, and intervening if required. Failure to follow this instruction could result in the loss of control of your vehicle, personal injury or death.

1.  Press the button on the touchscreen.

2. Press **Driver Assistance**.

3. Switch **Auto Hold** on or off.

Note: You can only switch the system on after you close the driver door.

Note: The system remembers the last setting when you start your vehicle.

Note: When using one pedal drive or an automatic car wash, make sure to switch auto hold off, or shift to neutral (N) with the brake pedal applied to ensure auto hold is not active.

USING AUTO HOLD

1. Bring your vehicle to a complete stop. The auto hold active indicator illuminates in the information display.
2. Release the brake pedal. The system holds your vehicle at a standstill. The auto hold active indicator remains illuminated in the information display.
3. Apply the accelerator and drive off in a normal manner. The system releases the brakes and the auto hold active indicator switches off.

Note: The system only activates if you apply enough brake pressure on the brake pedal to bring the vehicle to a standstill.

Note: Under certain conditions, the system could apply the electric parking brake. The brake system warning lamp illuminates. The electric parking brake releases when you press the accelerator pedal. See **Automatically Releasing the Electric Parking Brake** (page 198).

Note: Auto hold cancels if you shift into reverse (R), or neutral (N), and press the brake pedal.

There could be actions that can cause the auto hold system not to work when the following occur:

- When you use active park assist.
- The driver door is open.
- You shift into reverse (R), or neutral (N) before the system is active.
- Your vehicle is in temporary neutral mode.

AUTO HOLD INDICATORS



Illuminates when the system is active.

Auto Hold



Illuminates when the system is on but cannot hold your vehicle at a standstill at this particular time.

Traction Control

WHAT IS TRACTION CONTROL

The traction control system helps to avoid drive wheel spin and loss of traction.

HOW DOES TRACTION CONTROL WORK

If your vehicle begins to slide, the system applies the brakes to individual wheels and, when needed, reduces power at the same time. If the wheels spin when accelerating on slippery or loose surfaces, the system reduces power in order to increase traction.

SWITCHING TRACTION CONTROL ON AND OFF



WARNING: Operating your vehicle with the traction control disabled could lead to an increased risk of loss of vehicle control, vehicle rollover, personal injury and death.

The system turns traction control and stability control on each time you power on your vehicle.

The switch for the stability and traction control system is on the instrument panel.

If you press the switch, it will turn traction control off.

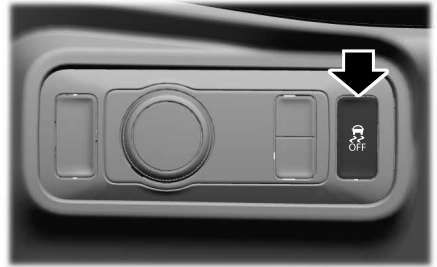

When you switch the system off, a message and an illuminated icon appear on the instrument cluster.

Use the switch again to return the traction control system to normal operation.

If your vehicle is stuck in mud or snow, switching traction control off may be beneficial as this allows the wheels to spin.

Note: *When you switch traction control off, stability control remains fully active.*

Your vehicle could have MyKey restrictions regarding this feature. See **What Is MyKey** (page 69).

TRACTION CONTROL INDICATOR

System Indicator Lights



Traction Control

TRACTION CONTROL – TROUBLESHOOTING

TRACTION CONTROL – WARNING LAMPS

System Messages



The traction control light temporarily illuminates on

start-up and flashes when activated by a driving condition.

The traction control off light temporarily illuminates on start-up and stays on:

- When you switch the traction control system off.
- When you select an alternative stability control mode.
- If a problem occurs in the system.

TRACTION CONTROL – INFORMATION MESSAGES

Message	Action
ESC Service required	The system detects a condition that requires service. Contact an authorized dealer as soon as possible.

Stability Control

HOW DOES STABILITY CONTROL WORK



WARNING: Vehicle modifications involving braking system, aftermarket roof racks, suspension, steering system, tire construction and wheel and tire size may change the handling characteristics of your vehicle and may adversely affect the performance of the electronic stability control system. In addition, installing any stereo speakers may interfere with and adversely affect the electronic stability control system. Reducing the effectiveness of the electronic stability control system could lead to an increased risk of loss of vehicle control, vehicle rollover, personal injury and death.



WARNING: Remember that even advanced technology cannot defy the laws of physics. It's always possible to lose control of a vehicle due to inappropriate driver input for the conditions. Aggressive driving on any road condition can cause you to lose control of your vehicle increasing the risk of personal injury or property damage. Activation of the electronic stability control system is an indication that at least some of the tires have exceeded their ability to grip the road; this could reduce the operator's ability to control the vehicle potentially resulting in a loss of vehicle control, vehicle rollover, personal injury and death.

If a driving condition activates either the stability control or the traction control system you may experience the following conditions:

- The stability and traction control light flashes.
- Your vehicle slows down.
- Reduced power.

The stability control system has several features built into it to help you maintain control of your vehicle:

Electronic Stability Control

Electronic stability control enhances your vehicle's ability to prevent skids or lateral slides by applying brakes to one or more of the wheels individually and, if necessary, reducing power.

Curve Control

Curve control enhances your vehicle's ability to follow the road when cornering severely or avoiding objects in the roadway. Curve control operates by reducing power and, if necessary, applying brakes to one or more of the wheels individually.

Traction Control

Traction control enhances your vehicle's ability to maintain traction of the wheels by detecting and controlling wheel spin. See **What Is Traction Control** (page 211).

Stability Control

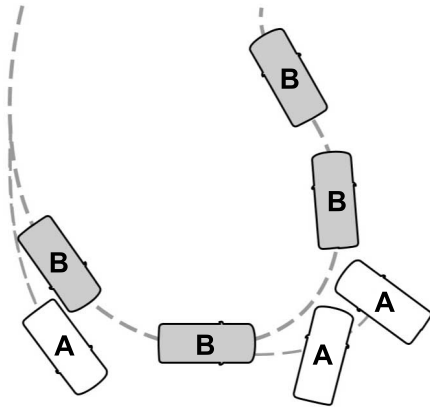

- A Vehicle without stability control skidding off its intended route.
- B Vehicle with stability control maintaining control on a slippery surface.

SWITCHING STABILITY CONTROL ON AND OFF

The system turns traction control and stability control on each time you power on your vehicle.

You can switch these systems off by using the button to the left of the steering wheel.

If you press the button, it will turn traction control off. See **Switching Traction Control On and Off** (page 211).

If you press and hold for 5 seconds, it turns stability control off.



Shifting into reverse (R) disables the system.

Note: With electronic stability control off, E-AWD protection controls remain active and could be noticeable in slippery conditions.

Note: While stability control can be turned off in any drive mode, the acceleration response in engage mode provides the most refined longitudinal control of the vehicle.

Note: When you choose the drive mode **Untame** and electronic stability control is off, it reduces the level of deceleration.

Stability Control

ESC Features				
Button Functions	Mode	Stability Control Off Light	Electronic Stability Control	Traction Control System
Default at start-up	-	On during bulb check	Enabled	Enabled
Button pressed momentarily	Traction control off	On	Enabled	Disabled
Button pressed and held more than five seconds	ESC disabled	On	Disabled	Disabled
Button pressed again after deactivation	ESC fully enabled	Off	Enabled	Enabled

Stability Control

STABILITY CONTROL INDICATOR



If it does not illuminate when you switch the power on, or remains on, this indicates a malfunction.

Have your vehicle checked by an authorized dealer as soon as possible.

Steering

ELECTRIC POWER STEERING

ELECTRIC POWER STEERING PRECAUTIONS



WARNING: The electric power steering system has diagnostic checks that continuously monitor the system. If a fault is detected, a message displays in the information display. Stop your vehicle as soon as it is safe to do so. Switch the vehicle off. After at least 10 seconds, switch the vehicle on and watch the information display for a steering system warning message. If a steering system warning message returns, have the system checked as soon as possible.



WARNING: If the system detects an error, you may not feel a difference in the steering, however a serious condition may exist. Have your vehicle checked as soon as possible. Failure to do so may result in loss of steering control.

Adapt your speed and driving behavior according to reduced steering assist.

Extreme continuous steering may increase the effort to steer. This occurs to prevent internal overheating and damage to the steering system. If this occurs, you will not lose the ability to steer your vehicle manually nor will it cause damage to the system. Normal steering and driving allows the system to cool down and steering assist returns to normal.

Note: *There is no fluid reservoir to check or fill.*

ELECTRIC POWER STEERING ADAPTIVE STEERING

Adaptive Learning (If Equipped)

Adaptive learning helps correct road irregularities and improves overall handling and steering. It communicates with the brake system to help operate advanced stability control and crash avoidance systems.

Note: *When the battery is disconnected or a new battery is installed, you must drive your vehicle a short distance before the system relearns the strategy and reactivates all systems.*

Steering Tips

If the steering wanders or pulls, check for:

- An improperly inflated tire.
- Uneven tire wear.
- Loose or worn suspension components.
- Improper vehicle alignment.

Note: *A high crown in the road or high crosswinds could also make the steering wander or pull.*

Steering

STEERING – TROUBLESHOOTING

STEERING – INFORMATION MESSAGES

Message	Action
Steering malfunction Service now	The power steering system has detected a condition that requires service. Have your vehicle checked as soon as possible.
Steering loss Stop safely	The power steering system is not working. Stop your vehicle in a safe place. Have your vehicle checked as soon as possible.
Steering assist malfunction Service required	The power steering system has detected a condition that requires service. Have your vehicle checked as soon as possible.
Steering Lock Malfunction Service Now	The steering system has detected a condition that could prevent you from starting your vehicle. Have your vehicle checked as soon as possible.

Parking Aids

PARKING AID PRECAUTIONS



WARNING: To help avoid personal injury, always use caution when in reverse (R) and when using the sensing system.



WARNING: The system may not detect objects with surfaces that absorb reflection. Always drive with due care and attention. Failure to take care may result in a crash.



WARNING: Traffic control systems, fluorescent lamps, inclement weather, air brakes, external motors and fans may affect the correct operation of the sensing system. This may cause reduced performance or false alerts.



WARNING: The system may not detect small or moving objects, particularly those close to the ground.



WARNING: The parking aid system can only assist you to detect objects when your vehicle is moving at parking speeds. To help avoid personal injury you must take care when using the parking aid system.



WARNING: The system may not function if the sensor is blocked.



WARNING: In cold and severe weather conditions the system may not function. Rain, snow and spray can all limit sensor performance.



WARNING: If damage occurs in the immediate area surrounding the sensor, have your vehicle checked as soon as possible.

Note: If your vehicle sustains damage leaving the sensors misaligned, this will cause inaccurate measurements or false alerts.

When you connect a trailer to your vehicle, the rear parking aid detects the trailer and provides an alert. Disable the parking aid when you connect a trailer to prevent the alert.

Note: Connected trailers might be detected by the vehicle and parking aid turns off automatically in those instances.

Note: Certain add-on devices installed around the bumper or fascia may create false alerts, for example, large trailer hitches, bike or surfboard racks, license plate brackets, bumper covers or any other device that could block the normal detection zone of the parking aid system. Aftermarket spare tires or spare tire covers mounted to the rear tailgate could cause false alerts from the park aid system. Remove the add-on device to prevent false alerts.

Note: Keep the sensors free from snow, ice and large accumulations of dirt. If the sensors are covered, the system's accuracy can be affected.

Do not clean the sensors with sharp objects.

Note: When using a programmed MyKey, you cannot switch the parking aids off. See **MyKey™** (page 69).

SWITCHING PARKING AID ON AND OFF



Press the parking aid button and use the menu to turn the system on and off.

The system can also be turned off using the pop-up message that appears when you are in reverse (R).

Parking Aids

REAR PARKING AID

WHAT IS THE REAR PARKING AID

Reverse Sensing System

Rear parking sensors detect objects behind your vehicle when in reverse (R).

REAR PARKING AID LIMITATIONS

There is a decreased coverage area at the outer corners.

When using a programmed MyKey, you cannot switch the rear parking aid off.

The rear parking aid sensors are active when your vehicle is in reverse (R) and the vehicle speed is less than 8 km/h (5 mph).

The sensor coverage area is up to 180 cm (71 in) from the rear bumper.

The rear parking aid detects large objects when you shift into reverse (R) and any of the following occur:

- Your vehicle is moving backward at a low speed.
- Your vehicle is stationary but an object is approaching the rear of your vehicle at a low speed.
- Your vehicle is moving backward at a low speed and an object is moving towards your vehicle, for example another vehicle at a low speed.

The system shall provide no audible warning for the object behind the vehicle when in neutral (N) gear.

LOCATING THE REAR PARKING AID SENSORS



The rear parking aid sensors are in the rear bumper.

REAR PARKING AID AUDIBLE WARNINGS

A warning tone sounds when your vehicle approaches an object. As your vehicle moves closer to an object, the rate of the tone increases. The warning tone continuously sounds when an object is 30 cm (12 in) or less from the rear bumper.

If your vehicle remains stationary for a few seconds, the audible warning turns off. If your vehicle moves backward the tone sounds again.

Note: *When the parking aid system sounds a tone, the audio system could reduce the set volume.*

FRONT PARKING AID

WHAT IS THE FRONT PARKING AID

Front parking sensors detect objects in front of your vehicle.

Parking Aids

FRONT PARKING AID LIMITATIONS

The front parking aid sensors are active when your vehicle is in any position other than park (P) and the vehicle speed is less than 8 km/h (5 mph).

The sensor coverage area is up to 70 cm (28 in) from the bumper.

If your vehicle is in reverse (R), the front parking aid detects objects when your vehicle is moving at a low speed or an object is moving toward your vehicle and provides an audible warning, for example another vehicle at a low speed. If your vehicle remains stationary for a few seconds, the audible warning turns off. Visual indication is always active in reverse (R).

If your vehicle is in any forward gear, the front parking aid provides audible warnings and visual indication when your vehicle is moving at a speed of 8 km/h (5 mph) or below and the system detects an object within the detection zone. If your vehicle remains stationary for a few seconds, the visual indication and audible warning turns off.

If your vehicle is in neutral (N), the front and rear sensors provide visual indication only when your vehicle is moving below a speed of 8 km/h (5 mph) and obstacles are detected inside the detection areas. Once your vehicle stops, the visual indication and audible warning stops after a few seconds.

LOCATING THE FRONT PARKING AID SENSORS



The front parking aid sensors are in the front bumper.

FRONT PARKING AID AUDIBLE WARNINGS

A warning tone sounds when there is an object within 70 cm (28 in) from the front bumper. As your vehicle moves closer to an object, the rate of the tone increases.

The warning tone continuously sounds when an object is 30 cm (12 in) or less from the front bumper.

Note: *If the detected object is 30 cm (12 in) or less from your vehicle, visual indication remains on.*

SIDE PARKING AID

WHAT IS THE SIDE PARKING AID

The front and rear outermost parking aid sensors map objects that are near to the sides of your vehicle.

SIDE PARKING AID LIMITATIONS

The sensor coverage is up to 60 cm (24 in) from the sides of your vehicle.

Parking Aids

The side parking aid may not function if:

- Your vehicle remains stationary for over two minutes.
- The anti-lock brake system activates.
- The traction control system activates.
- Your vehicle is in park (P).
- The steering wheel angle information is not available. You must drive at least 150 m (492 ft) above 30 km/h (19 mph) to reset the steering wheel angle information.

Note: *If you switch traction control off, the side sensing system also turns off.*

To reinitialize the system, drive the length of your vehicle.

The side parking aid does not detect an object that is moving toward the side of your vehicle, for example another vehicle moving at a low speed, if it does not pass a front or rear parking aid sensor.

If the transmission is in reverse (R), the side sensing system provides audible warnings. When your vehicle is moving slowly, obstacles are detected within 60 cm (24 in) and are inside the driving path of your vehicle. If your vehicle remains stationary for a few seconds, the audible warning turns off. Visual indication is always present in reverse (R).

If your vehicle is in neutral (N), the side sensing system provides visual indication only when your vehicle is moving slowly and there is a front or rear parking aid obstacle detected, and the side obstacle is within 60 cm (24 in) from the side of your vehicle. If your vehicle remains stationary for a few seconds, the visual indication turns off.

If the transmission is in drive (D) or any other forward gear, the side sensing system provides audible and visual warnings. When your vehicle is moving slowly, obstacles are detected within 60 cm (24 in) and are inside the driving path of your vehicle. If your vehicle remains stationary for a few seconds, the visual indication and audible warning turns off.

LOCATING THE SIDE PARKING AID SENSORS



The side parking sensors are located in the sides of the front and rear bumpers.

SIDE PARKING AID AUDIBLE WARNINGS

When the side parking aid detects an object within the coverage area and the driving path of your vehicle, an audible warning sounds. As your vehicle moves closer to the object, the rate of the tone increases.

Parking Aids

PARKING AID INDICATORS

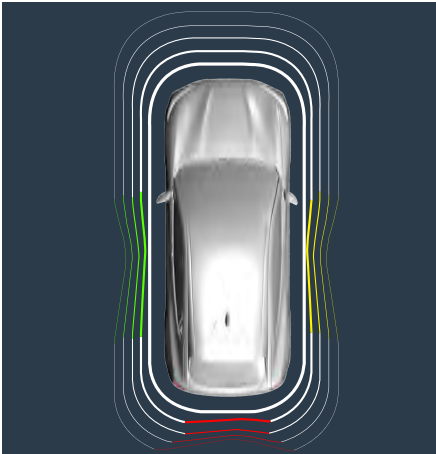

The system provides object distance indication through the information and entertainment display.

- As the distance to the object decreases, the indicator waves and the lines move toward the vehicle icon.
- If there is no object detected, the distance indicator lines are grey.

Visual indication remains on when your vehicle is in reverse (R). In any other gear, when you stop your vehicle, visual indication turns off after four seconds.

If the parking aids are not available, the side distance indicator lines do not display.

PARKING AIDS – TROUBLESHOOTING

PARKING AIDS – INFORMATION MESSAGES

If a fault is present in the parking aids, a warning message appears in the instrument cluster or the touchscreen.

Note: *When the front or rear park aid presents a fault message, the side parking aid also disables.*

Message	Action
Check front Park Pilot	The system detects a condition that requires service. Have your vehicle checked as soon as possible.
Check rear Park Pilot	The system detects a condition that requires service. Have your vehicle checked as soon as possible.
Front Park Pilot On Off	Displays the park aid status.
Rear Park Pilot On Off	Displays the park aid status.

Rear View Camera

WHAT IS THE REAR VIEW CAMERA

The rear view camera provides a video image of the area behind your vehicle when the transmission is in reverse (R).

REAR VIEW CAMERA PRECAUTIONS



WARNING: The rear view camera system is a reverse aid supplement device that still requires the driver to use it in conjunction with the interior and exterior mirrors for maximum coverage.



WARNING: Objects that are close to either corner of the bumper or under the screen due to the limited coverage of the camera system.



WARNING: Reverse your vehicle slowly. Failure to follow this instruction could result in the loss of control of your vehicle, personal injury or death.



WARNING: Use caution when the tailgate is ajar. If the tailgate is ajar, the camera is out of position and the video image could be incorrect. All guide lines disappear when the tailgate is ajar. Failure to follow this instruction could result in personal injury.



WARNING: Use caution when turning camera features on or off when the transmission is not in park (P). Make sure your vehicle is not moving.

Note: If the image comes on while the transmission is not in reverse (R), have the system inspected by your authorized dealer.

LOCATING THE REAR VIEW CAMERA

The rear view camera is on the liftgate. It provides a video image of the area behind your vehicle.

REAR VIEW CAMERA GUIDE LINES

Note: Active guide lines and fixed guide lines are only available when the transmission is in reverse (R).

Note: The centerline is only available if the active or fixed guide lines are on.

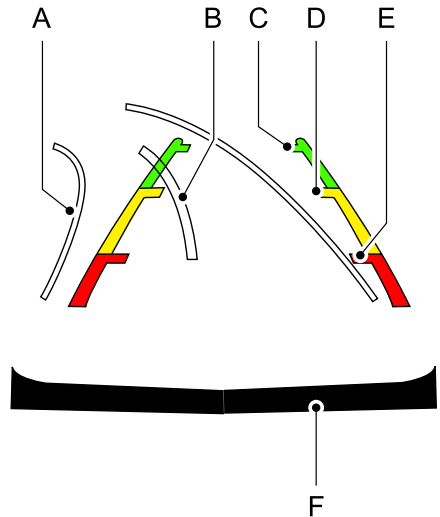

- A. Active guide lines.
- B. Centerline.
- C. Fixed guide line: Green zone.

Rear View Camera

- D. Fixed guide line: Yellow zone.
- E. Fixed guide line: Red zone.
- F. Rear bumper.

Active guide lines only show with fixed guide lines. To use active guide lines, turn the steering wheel to point the guide lines toward an intended path. If the steering wheel position changes while reversing, your vehicle might deviate from the intended path.

The fixed and active guide lines fade in and out depending on the steering wheel position. The active guide lines do not display when the steering wheel position is straight.

Use caution while reversing. Objects in the red zone are closest to your vehicle and objects in the green zone are farther away. Objects get closer to your vehicle as they move from the green zone to the yellow or red zones. Use the side view mirrors and rear view mirror to get better coverage on both sides and rear of your vehicle.

REAR VIEW CAMERA OBJECT DISTANCE INDICATORS

The system provides an image of your vehicle and the sensor zones. The zones highlight green, yellow, and red when the parking aid sensors detect an object in the coverage area.

REAR VIEW CAMERA SETTINGS

ZOOMING THE REAR VIEW CAMERA IN AND OUT

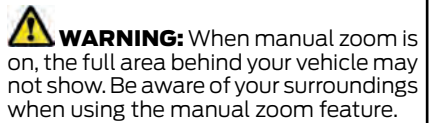

Selectable settings for this feature are zoom in (+) and zoom out (-). Press the symbol on the camera screen to change the view. The default setting is zoom off.

This allows you to get a closer view of an object behind your vehicle. The zoomed image keeps the bumper in the image to provide a reference. The zoom is only active while the transmission is in reverse (R).

Note: *Manual zoom is only available when the transmission is in reverse (R).*

Note: *Only the centerline shows when you enable manual zoom.*

SWITCHING REAR VIEW CAMERA DELAY ON AND OFF

1.  Press the button on the touchscreen.
2. Press **Driver Assistance**.
3. Switch **Rear View Camera Delay** on or off.

Rear View Camera

When shifting the transmission out of reverse (R) and into any gear other than park (P), the camera image remains in the display until:

- Your vehicle speed reaches approximately 8 km/h (5 mph).
- You shift your vehicle into park (P).

360 Degree Camera

WHAT IS THE 360 DEGREE CAMERA

The 360 degree camera system provides visibility around your vehicle in parking maneuvers such as:

- Centering in a parking space.
- Obstacles near your vehicle.
- Parallel parking.

The 360 degree camera system consists of front, side and rear cameras.

HOW DOES THE 360 DEGREE CAMERA WORK

The 360 Degree Camera system:

- Allows you to see what is directly in front of or behind your vehicle.
- Provides a cross traffic view in front of and behind your vehicle.
- Allows you to see a top-down view of the area outside your vehicle, including the blind spots and obstacles near your vehicle.

360 DEGREE CAMERA PRECAUTIONS



WARNING: The 360 degree camera system still requires the driver to use it in conjunction with looking out of the windows, and checking the interior and exterior mirrors for maximum coverage.



WARNING: Objects that are close to either corner of the bumper or under the bumper, might not be seen on the screen due to the limited coverage of the camera system.



WARNING: When manual zoom is on, the full area behind your vehicle may not show. Be aware of your surroundings when using the manual zoom feature.



WARNING: Do not switch the camera features on or off when your vehicle is moving.



WARNING: You are responsible for controlling your vehicle at all times. The system is designed to be an aid and does not relieve you of your responsibility to drive with due care and attention. Failure to follow this instruction could result in the loss of control of your vehicle, personal injury or death.

360 DEGREE CAMERA LIMITATIONS

Note: Use caution if a door is ajar. The 360 degree camera could be out of position and the image could be incorrect.

LOCATING THE 360 DEGREE CAMERAS

Rear View Camera

The rear view camera is on the liftgate. It provides a video image of the area behind your vehicle.

Front View Camera

The front view camera is in the grille. It provides a video image of the area in front of your vehicle.

360 Degree Camera

Side View Camera

The side view camera is on the outside mirror. It provides a video image of the area on the sides of your vehicle to aid you when parking.

360 DEGREE CAMERA GUIDE LINES

Note: Active guide lines are only available when the transmission is in reverse (R).

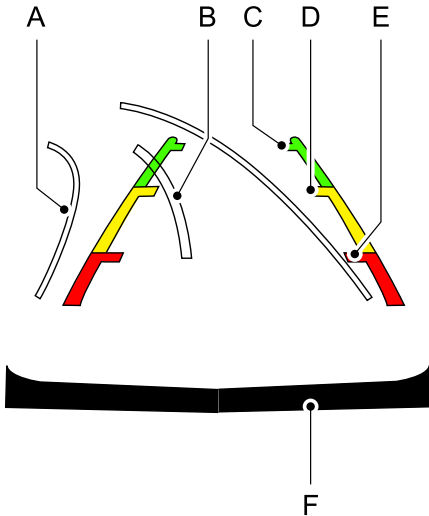

- A Active guide lines.
- B Centerline.
- C Fixed guide line: Green zone.
- D Fixed guide line: Yellow zone.

- E Fixed guide line: Red zone.
- F Rear bumper.

Active guide lines only show with fixed guide lines. Turn the steering wheel to point the guide lines toward an intended path. If the steering wheel position changes when reversing, your vehicle could deviate from the intended path.

The fixed and active guide lines fade in and out depending on the steering wheel position. The active guide lines do not display when the steering wheel position is straight.

Objects in the red zone are closest to your vehicle and objects in the green zone are farther away. Objects get closer to your vehicle as they move from the green zone to the yellow or red zones. Use the side view mirrors and rear view mirror to get better coverage on both sides and rear of your vehicle.

Keep Out Zone

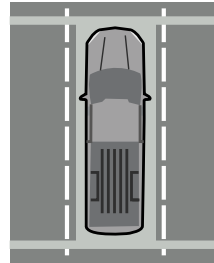

The keep out zone is represented by the yellow dotted lines running parallel to your vehicle.

360 Degree Camera

360 DEGREE CAMERA SETTINGS

SWITCHING THE 360 DEGREE CAMERA ON AND OFF

-  Press the button on the touchscreen.
- Press **CONTROLS**.
- Press **Camera**.

Note: When the camera button is pressed, the front 360 camera view is shown as default and other front camera views are accessed from the screen.

Note: The rear view camera activates when you switch into reverse (R).

The following camera views can be changed on the touchscreen:

- Normal view.
- Normal view with 360.
- Split view.

When in park (P), neutral (N) or drive (D), only the front images display when the button is pressed.

Note: The 360 degree camera system turns off when your vehicle is traveling at low speed, except when in reverse (R).

SWITCHING THE 360 DEGREE CAMERA VIEW



Press to access the different camera views.



Normal + 360 view: Contains the normal camera view next to a 360 degree camera view.



Normal view: Provides an image of what is directly in front of or behind your vehicle.



Split view: Provides an extended view of what is in front of or behind your vehicle.



Zooms in on the image.

Active Park Assist (If Equipped)

WHAT IS ACTIVE PARK ASSIST

Assists you with parking in and out of parking spaces.

HOW DOES ACTIVE PARK ASSIST WORK

Active park assist uses sensors to detect parking spaces. The system steers, accelerates, brakes and shifts gears as necessary to maneuver into or out of a parking space.

ACTIVE PARK ASSIST PRECAUTIONS



WARNING: You must remain in your vehicle when the system turns on. At all times, you are responsible for controlling your vehicle, supervising the system and intervening, if required. Failure to take care may result in the loss of control of your vehicle, serious personal injury or death.



WARNING: The sensors may not detect objects in heavy rain or other conditions that cause interference.



WARNING: You are responsible for controlling your vehicle at all times. The system is designed to be an aid and does not relieve you of your responsibility to drive with due care and attention. Failure to follow this instruction could result in the loss of control of your vehicle, personal injury or death.



WARNING: Do not use the system with accessories that extend beyond the front or rear of your vehicle, for example a trailer hitch or bike rack. The system is not able to make corrections for the additional length of the accessories.

SWITCHING ACTIVE PARK ASSIST ON AND OFF



Press the parking aid button, then press the active park assist icon on the touchscreen to bring up full screen notifications.

Press the soft keys on the touchscreen to switch between the parallel park in, perpendicular park in, or parallel park out parking modes.

Canceling Active Park Assist

To cancel parking assistance at any time, shift out of neutral (N).

Pausing Active Park Assist

To pause parking assistance at any time, release the parking aid button.

If you open the passenger or rear doors, active park assist pauses.

To resume parking, press and hold the parking aid button again.

ENTERING A PARALLEL PARKING SPACE

1. Press the parking aid button.

Note: *The system detects other vehicles and curbs to find a parking space.*

2. Press the active park assist icon on the touchscreen.

Active Park Assist (If Equipped)

3. Use the turn signal lever to search for a parking space on the driver or passenger side of your vehicle.

Note: *If you do not use the turn signal lever, the system searches for a parking space on the passenger side of your vehicle.*

4. Drive your vehicle approximately 1 m (3 ft) away from and parallel to the other parked vehicles when searching for a parking space.

Note: *A tone sounds and a message appears in the information and entertainment display when active park assist finds a suitable parking space.*

5. Press and hold the brake pedal.
6. Release the steering wheel and shift into neutral (N).
7. Press and hold the parking aid button.
8. Release the brake pedal to allow your vehicle to park.

Note: *You can slow down your vehicle at any time by pressing the brake pedal.*

Note: *When parallel parking between objects, the system parks closer to the object in front of your vehicle to allow easier access to the luggage compartment.*

Note: *When parking is complete, your vehicle shifts into park (P).*

ENTERING A PERPENDICULAR PARKING SPACE

1. Press the parking aid button.

Note: *Active park assist does not recognize parking space lines and centers your vehicle between objects.*

2. Press the active park assist icon on the touchscreen.
3. Select perpendicular parking.

4. Use the turn signal lever to search for a parking space on the driver or passenger side of your vehicle.

Note: *If you do not use the turn signal lever, the system searches for a parking space on the passenger side of your vehicle.*

5. Drive your vehicle approximately 1 m (3 ft) away from and perpendicular to the other parked vehicles when searching for a parking space.

Note: *A tone sounds and a message appears in the information and entertainment display when active park assist finds a parking space.*

6. Press and hold the brake pedal.
7. Release the steering wheel and shift into neutral (N).
8. Press and hold the parking aid button.
9. Release the brake pedal to allow the vehicle to park.

Note: *Active park assist backs your vehicle into parking spaces.*

Note: *Active park assist aligns the front end of your vehicle with the lane side of the object next to it.*

Note: *When the system detects only one object, it allows enough distance to open the door on either side.*

Note: *You can slow down your vehicle at any time by pressing the brake pedal.*

Note: *When parking is complete, your vehicle shifts into park (P).*

EXITING A PARKING SPACE

Active park assist only assists leaving parallel parking spaces.

1. Press the parking aid button.
2. Press the active park assist icon on the touchscreen.
3. Select parallel park exit.

Active Park Assist (If Equipped)

4. Use the turn signal to choose the direction to exit the parking space.
5. Press and hold the brake pedal.
6. Release the steering wheel and shift into neutral (N).
7. Release the parking brake.
8. Press and hold the parking aid button.
9. Release the brake pedal to allow your vehicle to move.

Note: After active park assist drives your vehicle to a position where you can exit the parking space in a forward movement, a message appears instructing you to take full control of your vehicle.

10. Take control of your vehicle.

Note: You can slow down your vehicle at any time by pressing the brake pedal.

ACTIVE PARK ASSIST – TROUBLESHOOTING

ACTIVE PARK ASSIST – INFORMATION MESSAGES

Message	Action
Active Park Fault	The system requires service. Have your vehicle checked as soon as possible.

ACTIVE PARK ASSIST – FREQUENTLY ASKED QUESTIONS

Why does active park assist not operate correctly?

The system is unable to detect a vehicle, curb or object to park next to or in between. The system needs boundary objects to operate correctly.

Why does active park assist not search for a parking space?

You have switched traction control off.

Why does active park assist not search for a parking space?

The transmission is in reverse (R). Your vehicle must be moving forward to be able to detect a parking space.

Why does active park assist not offer a parking space?

The sensors could be blocked. For example, snow, ice or large accumulations of dirt. Blocked sensors can affect how the system functions.

Why does active park assist not offer a parking space?

The sensors in the front or rear bumper could be damaged.

Why does active park assist not offer a parking space?

There is not enough room in the parking space for your vehicle to safely park.

Why does active park assist not offer a parking space?

There is not enough space for the parking maneuver on the opposite side of the parking space.

Why does active park assist not offer a parking space?

The parking space is more than 1.5 m (5 ft) or less than 0.5 m (2 ft) away from your vehicle.

Why does active park assist not offer a parking space?

Your vehicle's speed is greater than 35 km/h (22 mph) for parallel parking or greater than 30 km/h (19 mph) for perpendicular parking.

Active Park Assist (If Equipped)

Why does active park assist not offer a parking space?

You recently disconnected or replaced the battery. After you reconnect the battery you must drive your vehicle on a straight road for a short period of time.

Why does active park assist not correctly position the vehicle into a parking space?

An irregular curb along the parking space prevents the system from correctly aligning your vehicle.

Why does active park assist not correctly position the vehicle into a parking space?

Vehicles or objects bordering the space could not be correctly parked.

Why does active park assist not correctly position the vehicle into a parking space?

Your vehicle stopped too far past the parking space.

Why does active park assist not correctly position the vehicle into a parking space?

The tires are not correctly installed or maintained. For example, using a spare tire, not inflated correctly, improper size, or of different sizes.

Why does active park assist not correctly position the vehicle into a parking space?

A repair or alteration changed the detection capabilities.

Why does active park assist not correctly position the vehicle into a parking space?

A parked vehicle has a high attachment. For example, a salt sprayer, snowplow or moving truck bed.

Why does active park assist not correctly position the vehicle into a parking space?

The parking space length, or position of parked objects, changes after your vehicle passes the space.

Why does active park assist not correctly position the vehicle into a parking space?

The temperature around your vehicle quickly changes. For example, driving from a heated garage into a cold outside temperature, or after leaving a car wash.

Adaptive Cruise Control

HOW DOES ADAPTIVE CRUISE CONTROL WITH STOP AND GO WORK

Adaptive cruise control with stop and go uses radar and camera sensors to maintain a set gap between your vehicle and the vehicle in front of you while following it to a complete stop. Stop and go can also be set to follow a vehicle directly in front of you and adjust the set speed, while you are at a complete stop.

ADAPTIVE CRUISE CONTROL PRECAUTIONS



WARNING: You are responsible for controlling your vehicle at all times. The system is designed to be an aid and does not relieve you of your responsibility to drive with due care and attention. Failure to follow this instruction could result in the loss of control of your vehicle, personal injury or death.



WARNING: Pay close attention to changing road conditions such as entering or leaving a highway, on roads with intersections or roundabouts, roads without visible lanes of travel, roads that are winding, slippery, unpaved, or steep slopes.



WARNING: The system is not a crash warning or avoidance system.



WARNING: Do not use tire sizes other than those recommended because this can affect the normal operation of the system. Failure to do so may result in a loss of vehicle control, which could result in serious injury.



WARNING: Do not use the system in poor visibility, for example fog, heavy rain, spray or snow.

When Following a Vehicle



WARNING: When following a vehicle that is braking, your vehicle does not always decelerate quickly enough to avoid a crash without driver intervention. Apply the brakes when necessary. Failure to follow this instruction could result in personal injury or death.

Hilly Condition Usage

You should select a lower gear when the system is active in situations such as prolonged downhill driving on steep slopes, for example in mountainous areas.

ADAPTIVE CRUISE CONTROL LIMITATIONS

Sensor Limitations



WARNING: On rare occasions, detection issues can occur due to the road infrastructures, for example bridges, tunnels and safety barriers. In these cases, the system may brake late or unexpectedly. At all times, you are responsible for controlling your vehicle, supervising the system and intervening, if required.



WARNING: If the system malfunctions, have your vehicle checked as soon as possible.



WARNING: Large contrasts in outside lighting can limit sensor performance.

Adaptive Cruise Control



WARNING: The system only warns of vehicles detected by the radar sensor. In some cases there may be no warning or a delayed warning. Apply the brakes when necessary. Failure to follow this instruction could result in personal injury or death.



WARNING: The system may not detect stationary or slow moving vehicles below 10 km/h (6 mph).



WARNING: The system does not detect pedestrians or objects in the road.



WARNING: The system does not detect oncoming vehicles in the same lane.



WARNING: The system may not operate properly if the sensor is blocked. Keep the windshield free from obstruction.



WARNING: The sensor may incorrectly track lane markings as other structures or objects. This can result in a false or missed warning.

The camera is mounted on the windshield behind the interior mirror. The radar sensor is in the lower grille.

Note: You cannot see the sensor. It is behind a fascia panel.

Note: Keep the front of your vehicle free of dirt, metal badges or objects. Vehicle front protectors, aftermarket lights, additional paint or plastic coatings could also degrade sensor performance.

A message displays if something obstructs the camera or the sensor. When something blocks the sensor, the system cannot detect a vehicle ahead and does not function. See **Adaptive Cruise Control – Information Messages** (page 246).

The radar sensor has a limited field of view. It may not detect vehicles at all or detect a vehicle later than expected in some situations. The lead vehicle image does not illuminate if the system does not detect a vehicle in front of you.



- 1 Camera.
- 2 Radar sensor.

Adaptive Cruise Control

Detection Issues Can Occur:

A

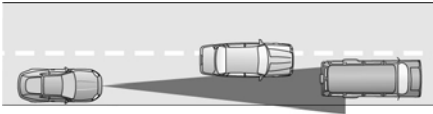

B

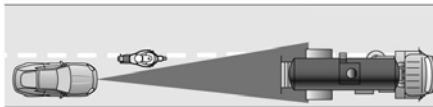

C

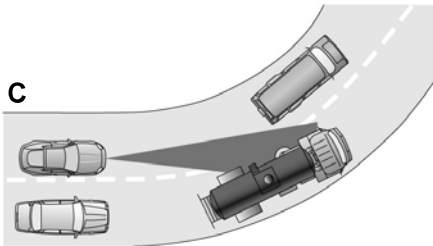

- A When driving on a different line than the vehicle in front.
- B With vehicles that edge into your lane. The system can only detect these vehicles once they move fully into your lane.
- C There may be issues with the detection of vehicles in front when driving into and coming out of a bend or curve in the road.

In these cases, the system may brake late or unexpectedly.

If something hits the front end of your vehicle or damage occurs, the radar-sensing zone could change. This could cause missed or false vehicle detection.

Optimal system performance requires a clear view of the road by the windshield-mounted camera.

Optimal performance may not occur if:

- The camera is blocked.
- There is poor visibility or lighting conditions.
- There are bad weather conditions.

SWITCHING ADAPTIVE CRUISE CONTROL ON AND OFF

The cruise controls are on the steering wheel.

Switching Adaptive Cruise Control On



Press the button to activate the system. When the system activates, the set speed is equal to whichever is greater, the current vehicle speed, or 15 mph when in imperial units or 20 km/h when in metric units. If the speed is too low, or other conditions are not correct for adaptive cruise control activation, the system enters standby mode. When you are below 15 mph when in imperial units or 20 km/h when in metric units, adaptive cruise control does not activate unless you are following another vehicle.

The indicator, current gap setting and set speed appear in the instrument cluster display.

Switching Adaptive Cruise Control Off



Press the button when the system is in standby mode or switch the ignition off.

Note: When you switch the system off, the set speed clears.

Adaptive Cruise Control

ADAPTIVE CRUISE CONTROL AUTOMATIC CANCELLATION

The system may cancel if:

- The tires lose traction.
- You apply the parking brake.

The system may cancel and set the parking brake if:

- You unbuckle the seatbelt and open the driver door after adaptive cruise control stops your vehicle.
- Adaptive cruise control holds your vehicle at a stop continuously for more than three minutes.

The system may deactivate or prevent activating when requested if:

- The vehicle has a blocked sensor.
- The brake temperature is too high.
- There is a failure in the system or a related system.

SETTING THE ADAPTIVE CRUISE CONTROL SPEED

Drive to the speed you prefer.

SET+

Press the toggle button upward or downward to set the current speed.

SET-

Take your foot off the accelerator pedal.

The indicator, current gap setting and set speed appear in the instrument cluster display when initially activating adaptive cruise control.

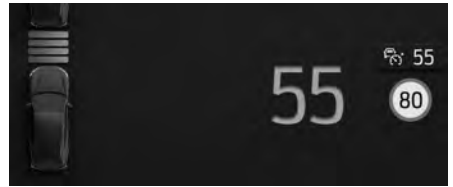

After a few seconds, the graphic in the instrument cluster display changes to show that adaptive cruise control is active.



A vehicle image illuminates if there is a vehicle detected in front of you.

Note: When adaptive cruise control is active, the speedometer may vary slightly from the set speed displayed in the instrument cluster display.

Adaptive Cruise Control

Setting the Adaptive Cruise Speed from a Complete Stop

SET+

Press the toggle button upward or downward while keeping the brake pedal fully pressed.

SET-

The set speed adjusts to 15 mph when in imperial units or 20 km/h when in metric units.

The indicator, current gap setting and set speed appear in the instrument cluster display.

Note: *The system will activate from a complete stop only when it detects a lead vehicle in close proximity.*

Manually Changing the Set Speed

SET+

Press and release the toggle button upward to increase the set speed in small increments.

Press and hold the toggle button upward to increase the set speed in large increments. Release the button when the set speed is equal to the desired speed.

SET-

Press and release the toggle button downward to decrease the set speed in small increments.

Press and hold the toggle button downward to decrease the set speed in large increments. Release the button when the set speed is equal to the desired speed.

You can also press the accelerator or brake pedal until you reach the speed you prefer. Press the toggle button upward or downward to select the current speed as the set speed.

The system may apply the brakes to slow the vehicle to the new set speed. The set speed continuously displays in the instrument cluster display when the system is active.

SETTING THE ADAPTIVE CRUISE CONTROL GAP



Press the button to cycle through the four gap settings.



The selected gap appears in the instrument cluster display as shown by the bars in the image.

Note: *The gap setting is time dependent and therefore, the distance adjusts with your vehicle speed.*

Note: *It is your responsibility to select a gap appropriate to the driving conditions.*

Adaptive Cruise Control

Adaptive Cruise Control Gap Settings

Graphic Display, Bars Indicated Between Vehicles	Gap Distance	Dynamic Behavior
1	Closest.	Sport.
2	Close.	Normal.
3	Medium.	Normal.
4	Far.	Comfort.

Each time you switch the system on, it selects the last chosen gap setting.

Following a Vehicle

When a vehicle ahead of you enters the same lane or a slower vehicle is ahead in the same lane, the vehicle speed adjusts to maintain the gap setting.

Note: *When you are following a vehicle and you switch on a turn signal lamp, adaptive cruise control may provide a small, temporary acceleration to help you pass.*

Your vehicle maintains a consistent gap from the vehicle ahead until:

- The vehicle in front of you accelerates to a speed above the set speed.
- The vehicle in front of you moves out of the lane you are in.
- You set a new gap distance.

The system applies the brakes to slow down your vehicle to maintain a safe gap distance from the vehicle in front of you. The system only applies limited braking. You can override the system by applying the brakes.

Note: *The brakes may emit noise when applied by the system.*

If the system determines that its maximum braking level is not sufficient, an audible warning sounds, a message appears in the instrument cluster display and an indicator flashes when the system continues to brake. Take immediate action.

CANCELING THE SET SPEED



Press the button or tap the brake pedal.

The set speed does not erase.

RESUMING THE SET SPEED



Press the button.

Your vehicle speed returns to the previously set speed and gap setting. The set speed displays continuously in the instrument cluster display when the system is active.

Note: *Only use resume if you are aware of the set speed and intend to return to it.*

Resuming the Set Speed from a Complete Stop

If your vehicle follows a vehicle to a complete stop and remains stationary for less than a few seconds, your vehicle accelerates from a stationary position to follow the vehicle ahead.

If your vehicle follows a vehicle to a complete stop and remains stationary for more than a few seconds, an indicator and message displays.

Adaptive Cruise Control



Message	Action
Stopped	Cruise control does not resume automatically when this display is active.
Press Resume Button	If the lead vehicle begins to move, you are prompted to press the resume button. Press and release the button or use the accelerator pedal to resume following the lead vehicle.
Auto-Resume	Displays when on a limited access highway after following a vehicle to a complete stop. In this situation, the vehicle resumes following the lead vehicle without a button press or pressing the accelerator pedal. The system can remain in auto-resume state for approximately 30 seconds, after which it no longer automatically resumes.

Adaptive Cruise Control

OVERRIDING THE SET SPEED



WARNING: If you override the system by pressing the accelerator pedal, it does not automatically apply the brakes to maintain a gap from any vehicle ahead.

When you press the accelerator pedal, you override the set speed and gap distance.

Use the accelerator pedal to intentionally exceed the set speed limit.

When you override the system, the green indicator illuminates and the vehicle icon does not appear in the instrument cluster display.

The system resumes operation when you release the accelerator pedal. The vehicle speed decreases to the set speed, or a lower speed if following a slower vehicle.

ADAPTIVE CRUISE CONTROL INDICATORS



Illuminates when you switch adaptive cruise control on. The color of the indicator changes to indicate the system status.

White indicates the system is on but inactive.

Green indicates that you set the speed and the system is active.

SWITCHING FROM ADAPTIVE CRUISE CONTROL TO CRUISE CONTROL



WARNING: Normal cruise control will not brake when your vehicle is approaching slower vehicles. Always be aware of which mode you have selected and apply the brakes when necessary.

1.  Press the button on the touchscreen.
2. Press **Driver Assistance**.
3. Press **Cruise Control**.
4. Press **Normal Cruise Control**.



The cruise control indicator replaces the adaptive cruise control indicator if you select normal cruise control. The gap setting does not display, and the system does not respond to lead vehicles. Automatic emergency braking remains active to maintain set speed. The system remembers the last setting when you start your vehicle.

LANE CENTERING

HOW DOES LANE CENTERING WORK

Adaptive cruise control with lane centering uses radar and camera sensors to help keep your vehicle in the middle of the lane by applying continuous assistance steering torque input toward the lane center on highways.

Note: *The adaptive cruise control gap setting operates normally.*

Adaptive Cruise Control

If you drive off-center within the lane, the system sets and maintains that preferred lane position. The system provides continuous assistance steering torque input toward the preferred position.

Note: *The system can only set preferred lane positions within the lane.*

Note: *If the system cancels, the preferred position erases. On the next activation, the system provides continuous assistance steering torque input toward the lane center.*

LANE CENTERING PRECAUTIONS



WARNING: Do not use the system when towing a trailer. Failure to follow this instruction could result in the loss of control of your vehicle, personal injury or death.



WARNING: Do not use the system if any changes or modifications to the steering wheel have been made. Any changes or modifications to the steering wheel could affect the functionality or performance of the system. Failure to follow this instruction could result in the loss of control of your vehicle, personal injury or death.

Adaptive cruise control precautions apply to lane centering unless stated otherwise or contradicted by a lane centering precaution. See **Adaptive Cruise Control Precautions** (page 234).

LANE CENTERING REQUIREMENTS

You must keep your hands on the steering wheel at all times.

The system only activates when all of the following occur:

- You have adaptive cruise control with stop and go on.
- Lane centering assist is enabled in your center display screen. See **Switching Lane Centering On and Off** (page 243).
- You have your hands on the steering wheel.
- The system detects both lane markings.

Note: *If it does not detect valid lane markings, the system stays inactive until valid markings are available.*

LANE CENTERING LIMITATIONS

Adaptive cruise control limitations apply to lane centering unless stated otherwise or contradicted by a lane centering limitation. See **Adaptive Cruise Control Limitations** (page 234).

Lane Centering may not correctly operate in any of the following conditions:

- The lane is too narrow or wide.
- The system does not detect at least one lane marking or when lanes merge or split.
- Limited steering torque input is applied.
- Areas under construction or new infrastructure.
- When modifications to the steering system have been made.
- When using a spare tire.
- In high wind conditions.

Note: *The driving assistance torque is limited and may not be sufficient for all driving situations such as driving through tight curves or driving through curves at high speeds.*

Adaptive Cruise Control

Note: In exceptional conditions, such as inclement weather or direct sunlight, the system could deviate from the center line or could cancel.

SWITCHING LANE CENTERING ON AND OFF

You must keep your hands on the steering wheel at all times.

The controls are on the steering wheel.



Press the button.

The indicator appears in the instrument cluster display. When the system is on, the color of the indicator changes to indicate the system status.

You can override the system at any time by steering your vehicle.

Note: The correct requirements must be met before you can switch the system on. See **Lane Centering Requirements** (page 242).

Enabling and Disabling Lane Centering

1.  Press the button on the touchscreen.
2. Press **Driver Assistance**.
3. Press **Cruise Control**.
4. Press **Adaptive cruise control**.
5. Press **Lane Centring Assist**.

LANE CENTERING ALERTS

You must keep your hands on the steering wheel at all times.

When the system is active and detects no steering activity for a period of time, the system alerts you to put your hands on the steering wheel. If you do not react to the warnings the system cancels and slows your vehicle down to idle speeds while maintaining steering control. See **Lane Centering Automatic Cancellation** (page 243).

The system also alerts you if your vehicle crosses lane markings without detected steering activity.

Note: The system could detect a light grip or touch on the steering wheel as hands-off driving.

LANE CENTERING AUTOMATIC CANCELLATION

When an external condition cancels the system, for example, no lane markings available, a tone sounds and a message appears in the instrument cluster display.

If your vehicle starts to slow down, you must provide steering input to the wheel and press the accelerator pedal to regain full system performance.

Automatic cancellation can also occur if:

- The lane becomes too wide or too narrow.
- The system cannot detect valid lane markings.
- Lane markings cross over one another.

Note: The system disables until the next key cycle if your vehicle slows down due to driver inactivity twice within a key cycle.

LANE CENTERING MANUAL CANCELLATION

When you perform the following actions, adaptive cruise control with lane centering will cancel:

Adaptive Cruise Control

- The brake pedal is pressed.
- Adaptive cruise control button is switched off on the steering wheel.

The lane centering system is momentarily suppressed when either of the following actions are performed:

- Turn signal indicator is latched or tapped.
- You steer the vehicle out of lane.

LANE CENTERING INDICATORS



Illuminates when you switch lane centering on. The color of the indicator changes to indicate the system status.

Gray status indicates the system is on but in standby mode.

Green status indicates the system is enabled and applying steering assistance to keep the vehicle in the center of the lane.

Amber status with an audible tone, that then changes to gray status, indicates a system automatic cancellation.

PREDICTIVE SPEED ASSIST

HOW DOES PREDICTIVE SPEED ASSIST WORK

Predictive Speed Assist works with adaptive cruise control and adjusts the vehicle speed to the road geometry and to the speed limit detected by the speed sign recognition system. As the system identifies curves, turns, roundabouts, highway exits, the vehicle speed temporarily decreases ahead of and during the changing road geometry. When passing new speed signs, the set speed updates. See **Predictive Speed Assist Precautions** (page 244).

There are limitations that affect the accuracy of the speed sign recognition system and its ability to determine the current speed limit. Predictive speed assist and its ability to determine the current speed limit shares these limitations.

Note: *The adaptive cruise control gap setting operates normally when the feature is enabled.*

PREDICTIVE SPEED ASSIST PRECAUTIONS



WARNING: You are responsible for controlling your vehicle at all times. The system is designed to be an aid and does not relieve you of your responsibility to drive with due care and attention. Failure to follow this instruction could result in the loss of control of your vehicle, personal injury or death.



WARNING: Pay close attention to changing road conditions. You may need to override the system by pressing the brake or accelerator pedal if the adjusted speed becomes higher or lower than necessary.



WARNING: The system only provides limited braking. Your vehicle may not always decelerate quickly enough to avoid a crash without driver intervention. Apply the brakes when necessary.



WARNING: The system does not activate the turn signal.

Adaptive cruise control precautions apply to predictive speed assist unless stated otherwise or contradicted by a predictive speed assist precaution. See **Adaptive Cruise Control Precautions** (page 234).

Adaptive Cruise Control

The system only applies limited braking. You can override the system with the accelerator pedal or cancel the system by applying the brakes.

The system may adapt to various factors such as time of day, lane width. This could influence speed adjustments and accelerations.

The system may adapt to various drive modes. See **Drive Mode Control** (page 256). This could influence speed adjustments and accelerations.

Note: *The system does not activate the turn signal automatically.*

PREDICTIVE SPEED ASSIST LIMITATIONS



WARNING: The system may not always adjust vehicle speed in certain road or weather conditions such as crossing traffic, yield or stop signs, right of way, traffic lights, speed bumps, rain, snow, fog. You must always apply the brake or accelerator pedal when necessary.

The road geometry and speed limit information provided by the navigation map data could be inaccurate or out of date.

The system may not detect and read speed limit signs with conditional information, for example, when a sign is flashing, during specific time ranges, or when children are present.

Note: *The system does not set the vehicle speed to speed limits shown with a supplementary traffic sign.*

Under certain conditions, the system may not adjust the vehicle speed until after your vehicle passes the speed limit.

Detection of road geometry operates only where related information is available. Road geometry information may not be available in some areas.

SWITCHING PREDICTIVE SPEED ASSIST MODE ON AND OFF

1.  Press the button on the touchscreen.
2. Press **Driver Assistance**.
3. Press **Cruise Control**.
4. Press **Adaptive cruise control**.
5. Switch **Predictive Speed Assist** on or off.

PREDICTIVE SPEED ASSIST ALERTS

If the speed sign recognition system detects a speed limit below the minimum adaptive cruise control set speed, a tone sounds and the system returns to standby mode.

PREDICTIVE SPEED ASSIST INDICATORS

A blue marker around the speed sign and a blue arrow next to the set speed indicates that the system is active.

Speed Sign Indicator

When the system detects a new speed sign, a gray indicator appears above the set speed while the system adjusts the vehicle speed to the speed limit. When the speed limit is reached, the set speed updates and the gray indicator disappears.

Adaptive Cruise Control

Road Geometry Indicator

When the system detects a curve, turn, roundabout, highway exit, the vehicle starts to decelerate, and the indicator appears and changes color.

Road Geometry Indicator Symbols



Left curve.



Right curve.



Left intersection.



Right intersection.



Left roundabout.



Right roundabout.

PREDICTIVE SPEED ASSIST – TROUBLESHOOTING

PREDICTIVE SPEED ASSIST – INFORMATION MESSAGES

Message	Action
Adaptive Cruise Control Speed Sign Recognition Not Available	Navigation system based speed limit information is not available. If the message continues to appear, have your vehicle checked as soon as possible.
Driver Resume Control	The system is going to cancel and you must take control.

ADAPTIVE CRUISE CONTROL – TROUBLESHOOTING

ADAPTIVE CRUISE CONTROL – INFORMATION MESSAGES - VEHICLES WITH: LANE CENTERING

Note: Depending on your vehicle options and instrument cluster type, not all messages display or are available.

Note: The system could abbreviate or shorten certain messages depending upon which cluster type you have.

Adaptive Cruise Control

Message	Action
Keep hands on steering wheel	Return your hands to the steering wheel and provide steering input to cancel the message.
Lane centring assist not available	To reset the feature when the vehicle is stationary, return the gear selector to park and turn the vehicle off. Restart the vehicle with your foot on the brake pedal.
Resume control	You must immediately take full control of the vehicle.
Press accelerator pedal to resume	Resume adaptive cruise control with lane centering by applying foot pressure on the accelerator pedal. You can also resume the feature by pressing the resume button on the steering wheel.

Adaptive Cruise Control

ADAPTIVE CRUISE CONTROL – INFORMATION MESSAGES - VEHICLES WITH: STOP AND GO

Note: Depending on your vehicle options and instrument cluster type, not all messages display or are available.

Note: The system could abbreviate or shorten certain messages depending upon which cluster type you have.

Message	Action
Adaptive cruise malfunction	A malfunction is preventing the adaptive cruise from engaging.
Front sensor not aligned	Contact an authorized dealer to have the radar checked for proper coverage and operation.
Adaptive cruise not available	Conditions exist preventing the system from being available.
Adaptive cruise not available Sensor blocked See manual	You have a blocked radar because of poor radar visibility due to inclement weather or ice, mud, or water in front of the radar. You can typically clean the sensor to resolve this. Due to the nature of radar technology, it is possible to get a blockage warning with no actual block. This happens, for example, when driving in sparse rural or desert environments. A false blocked condition either self clears, or clears after you restart your vehicle.
Cruise control active Adaptive braking off	You have selected normal cruise control. The system does not brake or react to traffic.
Adaptive cruise Driver resume control	Displays when the adaptive cruise control is going to cancel and you must take control.
Adaptive cruise Speed too low to activate	Displays when the vehicle speed is too slow to activate the adaptive cruise control and there is no lead vehicle in range.

BlueCruise - Vehicles With: Hands Free Driving

WHAT IS BLUECRUISE

BlueCruise keeps your vehicle centered in the lane and offers a hands-free driving mode in certain situations when using adaptive cruise control.

HOW DOES BLUECRUISE WORK

BlueCruise uses cameras to monitor your vehicle position within a lane and applies steering support to keep your vehicle centered in the lane.

Using the cameras and location information, BlueCruise allows you to remove your hands from the steering wheel and offers a hands-free driving mode in certain areas.

When active, BlueCruise uses a driver facing camera and infrared lighting to monitor your eyes and head position to detect if you are distracted. If the system determines you are distracted, it alerts you to return your eyes back to the road.

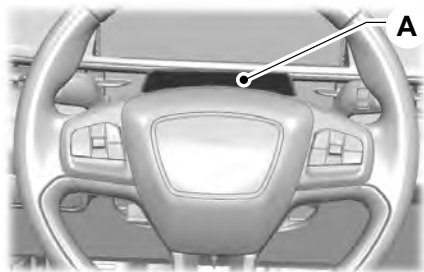



A Camera and lighting areas.

Note: When BlueCruise is active, in certain crash or near crash-like situations, such as an air bag deployment or hitting a road obstacle, camera data may record through the vehicle event data recorder. See **Event Data** (page 21).

Note: No data records under normal driving conditions.

BLUECRUISE PRECAUTIONS

 **WARNING:** You are responsible for keeping your eyes on the road at all times. The system is designed to be an aid and does not relieve you of your responsibility to drive with due care and attention. Failure to follow this instruction could result in the loss of control of your vehicle, personal injury or death.

 **WARNING:** You are responsible for controlling your vehicle at all times. The system is designed to be an aid and does not relieve you of your responsibility to drive with due care and attention. Failure to follow this instruction could result in the loss of control of your vehicle, personal injury or death.

 **WARNING:** Obstructions to the driver facing camera or infrared lighting could prevent the system from properly operating. Keep the camera and lighting areas free from obstruction. Failure to follow this instruction could result in the loss of control of your vehicle, personal injury or death.

BlueCruise - Vehicles With: Hands Free Driving



WARNING: Do not use the system if any changes or modifications to the steering wheel have been made. Any changes or modifications to the steering wheel could affect the functionality or performance of the system. Failure to follow this instruction could result in the loss of control of your vehicle, personal injury or death.



WARNING: The system may not function if the sensor is blocked.



WARNING: Pay close attention to changing road conditions such as entering or leaving a highway, on roads with intersections or roundabouts, roads without visible lanes of travel, roads that are unpaved, or steep slopes. Failure to follow this instruction could result in the loss of control of your vehicle, personal injury or death.



WARNING: The system is not a crash warning or avoidance system.



WARNING: Large contrasts in outside lighting can limit sensor performance.



WARNING: The system attempts to keep your vehicle in the center of the lane as well as maintain speed and gap control. The system may not be able to perform these tasks in all situations. Do not use the system in complex or uncertain driving conditions. Failure to follow this instruction could result in the loss of control of your vehicle, personal injury or death.



WARNING: Your vehicle could drift out of the lane of travel. Always be prepared to manually steer your vehicle. Failure to follow this instruction could result in the loss of control of your vehicle, personal injury or death.



WARNING: The system will not operate if the sensor cannot track the road lane markings.



WARNING: Do not use the system when towing a trailer. Failure to follow this instruction could result in the loss of control of your vehicle, personal injury or death.

BLUECRUISE REQUIREMENTS

BlueCruise only activates when all of the following occur:

- BlueCruise is enabled in your information and entertainment screen. See **BlueCruise Settings** (page 251).
- Adaptive cruise control is on.
- The system detects both lane markings.
- Your hands are on the steering wheel.
- Your eyes are on the road.
- Your vehicle is initially centered in the lane, between two line markings.

Note: For hands-free mode to work, your vehicle must be on certain limited access divided freeways.

Note: The system may require updated software for hands-free mode. See **Vehicle Software Updates** (page 391).

Note: BlueCruise hands-free mode is only available depending on local regulations and customer subscription.

BlueCruise - Vehicles With: Hands Free Driving

BLUECRUISE LIMITATIONS

Any of the following conditions could result in BlueCruise not correctly operating:

- You do not have your vehicle centered in the lane.
- The lane is too narrow or too wide.
- The curve in the road is too small.
- The system does not detect the minimum required lane markings or when lanes merge or split.
- When the required steering effort to maintain lane center exceeds the lane centering system limit.
- You are using the system in areas under construction.
- If you make any aftermarket modifications to the steering system.
- You are using a spare tire.
- When towing a trailer.
- Inclement weather conditions including, but not limited to, high wind, heavy rain, and fog.
- Driving into direct sunlight.

The driver-facing camera may not operate correctly due to any of the following:

- You have a pre-existing eye condition, such as an eye misalignment, or have had eye surgery.
- You cover your facial features by a mask, hat or other items.
- The lighting conditions change significantly.
- You are not in the field of view of the camera.
- You position or tilt yourself to one side.
- You are moving around extensively.
- You are wearing glasses or sunglasses that are too dark or reflective.

Note: The system has limited steering assistance and may not be sufficient for all driving situations.

Note: In exceptional conditions, such as inclement weather or direct sunlight, the system could deviate from the center line.

Note: The information provided by the navigation map data could be inaccurate or out of date.

BLUECRUISE SETTINGS

Enabling BlueCruise

1.  Press the button on the touchscreen.
2. Press **Driver Assistance**.
3. Press **Cruise Control**.
4. Press **Lane Centring with Hands-Free**.

Enabling Activation Prompts

1.  Press the button on the touchscreen.
2. Press **Driver Assistance**.
3. Press **Cruise Control**.
4. Press **Activation Prompts**.

SWITCHING BLUECRUISE ON AND OFF

Switching BlueCruise On

The controls are on the steering wheel.

Using Activation Prompts



When the prompt appears, press the button to switch BlueCruise on.

BlueCruise - Vehicles With: Hands Free Driving

The indicator appears in the instrument cluster. When the system is on, the color of the indicator changes to indicate the system status.

Note: *You must enable activation prompts in the touchscreen.*

Using Steering Wheel Controls



Using the adaptive cruise control and lateral support buttons, make sure both systems are active. BlueCruise activates.



Switching BlueCruise Off



To switch off BlueCruise, press the adaptive cruise control button or the lateral support button. When using the lateral support button confirm with ok



the question prompt display in the instrument cluster when the system is active or in standby mode.

BlueCruise Manual Cancellation

When you perform the following actions, BlueCruise will cancel:

- The brake pedal is pressed.

BlueCruise is momentarily suppressed when either of the following actions are performed:

- Turn signal indicator is latched or tapped.
- You steer the vehicle out of lane.

Note: *When switching the system on or off a message appears in the instrument cluster to show the status.*

Note: *The system always turns off when you start your vehicle.*

BLUECRUISE ALERTS

When BlueCruise is providing hands-on driving or transitioning to hands-on driving from hands-free driving and detects no steering activity for a certain period of time, the system alerts you with a message in the instrument cluster to put your hands on the steering wheel. After the first alert, the system alerts you with a message in the instrument cluster and an audible warning.

When BlueCruise is providing hands-on or hands-free driving and detects you are not looking at the road for a certain period of time, the system alerts you to return your eyes to the road. Depending on where you are looking, the alert can be a message in the instrument cluster and an audible warning.

If you do not react to the warnings, BlueCruise cancels, quickly activates and releases the brakes, and slows your vehicle down to low speeds while maintaining steering control.

If your vehicle slows down and you resume control, a message appears to prompt you to press the accelerator pedal to allow the system to resume.

The system also alerts you if your vehicle crosses lane line markings without detected steering activity.

Note: *If the system detects repeated inactivity, it disables until the next key cycle.*

BLUECRUISE AUTOMATIC CANCELLATION

When an external condition cancels BlueCruise, for example, no lane markings available, a tone sounds and a message appears in the instrument cluster.

System cancellation can also occur if:

BlueCruise - Vehicles With: Hands Free Driving

- The lane becomes too narrow.
- The system cannot detect valid lane markings.
- Lane markings cross.
- The curve of the road is too sharp.
- Your eyes are not on the road or your hands are not on the steering wheel.

If you have your hands on the steering wheel and your eyes are on the road when the feature is active and a cancellation occurs, the system sounds a tone and displays a cancelled graphic in the instrument cluster.

If you are not paying attention to the road or your hands are not on the steering wheel and a cancellation occurs, the system displays a message and a tone sounds until you resume control. If you do not resume control in time, BlueCruise quickly activates and releases the brakes, and slows your vehicle to low speeds while maintaining steering control. If your vehicle slows down and you resume control, a message appears to prompt you to press the accelerator pedal to allow the system to resume.

Note: *The system disables until the vehicle is turned off and back on if it detects repeated inactivity.*

BLUECRUISE INDICATORS



When on, the color of the indicator changes to indicate the status.

Gray indicates BlueCruise is on but inactive.

Green indicates BlueCruise is active and applying continuous steering support.

Blue indicates BlueCruise is active and hands-free driving mode is available.

Hands-On Driving Support Available



When this indicator is present, you must keep your hands on the steering wheel.

Hands-Free Driving Support Available

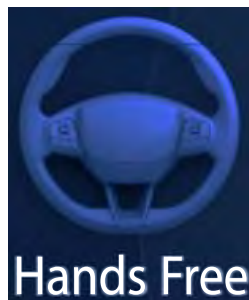

A graphic in the instrument cluster of a steering wheel without hands indicates the hands-free driving mode is available.

When this indicator is present, you can remove your hands from the steering wheel.

BlueCruise - Vehicles With: Hands Free Driving

IN-LANE REPOSITIONING

HOW DOES IN-LANE REPOSITIONING WORK

BlueCruise with in-lane repositioning uses the vehicle's front and corner radar sensors together with the front windshield camera sensor to operate.

Using these sensors, the system automatically adjusts your vehicle's position in the lane based on the current driving situation.

Note: *In-lane repositioning is active only when BlueCruise is enabled while traveling on divided highways and when any of the following occur:*

- Passing or being passed by adjacent lane vehicles in close proximity.
- In a curve.
- Driving in outer lanes.

Note: *In certain situations, the vehicle may bias without showing the indicators.*

Note: *Keep the front of your vehicle free of dirt, metal badges or objects. Vehicle front protectors, aftermarket lights, additional paint or plastic coatings could also degrade sensor performance.*

Note: *The radar sensor has a limited field of view. It may not detect vehicles at all or detect a vehicle later than expected in some situations.*

SWITCHING IN-LANE REPOSITIONING ON AND OFF

1.  Press the button on the touchscreen.
2. Press **Driver Assistance**.

3. Press **Cruise Control**.
4. Press **Adaptive cruise control**.
5. Press **Lane Centring with Hands-Free**.
6. Press In-Lane Repositioning to toggle the system on or off.

IN-LANE REPOSITIONING INDICATORS



Biased towards right-hand side of the lane.



Biased towards left-hand side of the lane.

BLUECRUISE – TROUBLESHOOTING

BLUECRUISE – INFORMATION MESSAGES

Depending on your vehicle options and instrument cluster type, not all messages display or are available.

BlueCruise - Vehicles With: Hands Free Driving

Message	Details
Keep hands on steering wheel	Make sure you return your hands to the steering wheel and provide steering input.
Resume control	The system is going to cancel and you must take control.
Watch the road	Return your attention to the road.
BlueCruise not available	Conditions exist preventing the system from being available. If the message continues to display, have the system checked as soon as possible.
Press accelerator pedal to resume	Press the accelerator pedal and follow the prompts.
Driver monitor camera cannot detect face See manual	Make sure your facial features are visible and in the field of view of the driver facing camera. It is possible that the steering column is positioned too high or low for the driver facing camera to see you, adjust the steering column or seat so your face is in the field of view.
Driver monitor camera is blocked See manual	Make sure your hands, arms or other objects are not obscuring the camera.
Driver monitor camera malfunction See manual	Conditions exist preventing the system from being available. If the message continues to display, have the system checked as soon as possible.
BlueCruise On Watch the road Be prepared to resume control	BlueCruise is active, keep your attention on the road.
BlueCruise available Press {ICON} to activate	The system is in standby mode, press the button on the steering wheel to activate.

Note: *The instrument cluster display may abbreviate or shorten certain messages depending on which cluster type you have.*

Drive Mode Control

WHAT IS DRIVE MODE CONTROL

Your vehicle has various drive modes that you can select for different driving conditions. Depending on the drive mode that you select, the system adjusts various vehicle settings, for example steering, instrument cluster graphics, ambient lighting, interior sound, handling and powertrain response.

SELECTING A DRIVE MODE

1.  Press the button on the touchscreen.
2. Press **CONTROLS**.
3. Select an available drive mode.

Note: *Drive mode changes may not be available when your vehicle is off.*

DRIVE MODES

ACTIVE - EXCLUDING: GT

For everyday driving. This mode is the perfect balance of excitement, comfort and convenience. Steering tunes for normal driving. The interior lights and cluster graphics are set to soft blue and the battery state of charge gauge displays.

ACTIVE - GT

For everyday driving. This mode is the perfect balance of excitement, comfort and convenience. Steering and active damping are tuned for normal driving. The interior lights and cluster graphics are set to soft blue and the battery state of charge gauge displays.

UNTAME - EXCLUDING: GT

Untame mode is for sporty driving with improved performance handling and response. This mode increases acceleration response and provides a strong deceleration rate when you lift off the accelerator pedal. Untame mode makes your vehicle accelerate faster. Steering tunes for performance. The interior sound increases, and the ambient lights and cluster graphics are set to orange with a graphic related to your acceleration and steering inputs.

UNTAME - GT

Untame mode is for sporty driving with improved performance handling and response. This mode increases acceleration response and provides a strong deceleration rate when you lift off the accelerator pedal. Untame mode makes your vehicle accelerate faster and provides sportier steering feel. Steering and active damping tunes for performance. The interior sound increases, and the ambient lights and cluster graphics are set to orange with a graphic related to your acceleration and steering inputs.

Untame Extend

This feature adjusts untame mode to provide high-performance driving and is for track and closed course use only. When you activate, this mode provides balanced power output for lap time consistency. The accelerator pedal calibrates for improved propulsion control. The system provides more performance orientated traction and stability control. In this mode, traction and stability control intervention reduces and tunes specifically for track usage only. The interior sound has increased presence and the ambient lights and cluster graphics are set to orange with a graphic related to your acceleration and steering inputs.

Drive Mode Control

To use this feature, you must be in untame mode with the untame plus slider selected with the battery at operating temperature. When using this mode, one pedal drive is not available and other driver assistance features disable.

Note: *This feature may not be available in temperatures below 0°C (32°F), or 15°C (59°F) for the battery.*

Note: *If the feature is not available, charge your vehicle until the battery has sufficient charge, and meets temperature conditions.*

WHISPER - EXCLUDING: GT

Whisper mode is for relaxed driving and adverse weather conditions. This is the best mode for driving in slippery conditions. This mode decreases accelerator response at partial inputs. Steering tunes for comfort. When you release the accelerator pedal, your vehicle slowly decelerates allowing for a more comfortable ride. The interior sound turns off and the ambient lights and cluster graphics are set to blue with a graphic that starts to illuminate blue as you drive efficiently at consistent speeds.

WHISPER - GT

Whisper mode is for relaxed driving and adverse weather conditions. This is the best mode for driving in slippery conditions. This mode decreases accelerator response at partial inputs. Steering and active damping tunes for comfort. When you release the accelerator pedal, your vehicle slowly decelerates allowing for a more comfortable ride. The interior sound turns off and the ambient lights and cluster graphics are set to blue with a graphic that starts to illuminate blue as you drive efficiently at consistent speeds.

One Pedal Drive

WHAT IS ONE PEDAL DRIVE

One pedal drive allows you to accelerate, slow down and stop using only the accelerator pedal. Pressing the accelerator down accelerates your vehicle, releasing pressure on the accelerator with your foot still on the pedal slows down your vehicle and releasing the pedal completely allows your vehicle to come to a complete stop if the road grade is not excessively steep.

See **One Pedal Drive Precautions** (page 258).

ONE PEDAL DRIVE PRECAUTIONS



WARNING: This system is an extra driving aid. It does not replace your attention and judgment, or the need to apply the brakes. This system does NOT automatically brake your vehicle. If you fail to press the brake pedal when necessary, you may collide with another vehicle.

Shifting into neutral (N) does not hold your vehicle at a standstill.

Shifting into drive (D) or reverse (R) does not cause the vehicle to move if the accelerator pedal is not pressed.

Note: Always check the transmission selection before accelerating.

Note: Switch off one pedal drive before entering a car wash.

ONE PEDAL DRIVE LIMITATIONS

One pedal drive is unavailable when any of the following occur:

- Shifting into an incorrect transmission position, such as park (P) when driving.
- Using active park assist.
- Using cruise control.
- Selecting a drive mode other than engage, whisper, or unbride. For example unbride extend (GT only) disables one pedal drive.
- Turning off stability control.

Releasing the accelerator pedal may not bring your vehicle to a complete stop on steep grades.

Increased vehicle load may reduce accelerator pedal ability to slow the vehicle.

SWITCHING ONE PEDAL DRIVE ON AND OFF

1.  Press the button on the touchscreen.
2. Press **CONTROLS**.
3. Switch **1-Pedal Drive** on or off.

ONE PEDAL DRIVE INDICATORS



When one pedal drive is active, the indicator displays in the instrument cluster.

Local Hazard Information

WHAT IS LOCAL HAZARD INFORMATION

 **WARNING:** You are responsible for controlling your vehicle at all times. The system is designed to be an aid and does not relieve you of your responsibility to drive with due care and attention. Failure to follow this instruction could result in the loss of control of your vehicle, personal injury or death.

The system is designed to provide near real-time information about the road in front of you.

LOCAL HAZARD INFORMATION INDICATORS



Animals on the road.



Approaching vehicle coming the wrong way.



Broken down vehicle or accident.



Broken down vehicle or accident.



Fire.



General.



Hazardous driving conditions.



Objects on the road.



People on the road.



Road works.



Traffic jam.

Note: Depending on your vehicle options and instrument cluster type, not all indicators shown are available.

ENABLING LOCAL HAZARD INFORMATION

1.  Press the button on the touchscreen.
2. Press **Driver Assistance**.
3. Switch **Local hazard information** on.

Speed Limiter

HOW DOES THE SPEED LIMITER WORK

The system allows you to set a speed, to which your vehicle becomes limited to. The set speed becomes the maximum speed for your vehicle, but with the option to temporarily exceed this limit.

SPEED LIMITER PRECAUTIONS



WARNING: When you are going downhill, your vehicle speed may increase above the set speed. The system will not apply the brakes but a warning displays. Failure to follow this warning could result in serious personal injury or death.

SWITCHING THE SPEED LIMITER ON AND OFF

LIM

Press to switch the system on. The system activates with the current vehicle speed as the set speed. Press again to switch the system off.

SETTING THE SPEED LIMIT

SET+

Press with the limiter in standby mode to set the limiter to the current vehicle speed. Speed limitation activates and the symbol in the instrument cluster appears green.

SET-

CHANGING THE SET SPEED LIMIT

SET+

You can adjust the set speed in small or large increments. Press the toggle button upward or downward once to adjust the set speed in small increments. Press and hold the toggle button upward or downward to adjust the set speed in large increments.

SET-

CANCELING THE SET SPEED LIMIT



Press to cancel the limiter and place it in standby mode. The symbol in the instrument cluster appears grey.

RESUMING THE SET SPEED LIMIT



Press again to resume the limiter. The symbol in the instrument cluster appears green.

INTENTIONALLY EXCEEDING THE SET SPEED LIMIT

Firmly press the accelerator to temporarily turn the system off. The system reactivates once your vehicle speed drops below the set speed.

SPEED LIMITER INDICATORS

LIM

It illuminates in the instrument cluster when the system is standby or active.

Speed Limiter

SPEED LIMITER AUDIBLE WARNINGS

If you accidentally exceed the set speed, the set speed indicator flashes and an audible warning tone sounds.

If you intentionally exceed the set speed, only the set speed indicator flashes.

Intelligent Speed Limiter

WHAT IS THE INTELLIGENT SPEED LIMITER

The system allows you to limit the vehicle speed to the maximum speed limit detected by the traffic sign recognition system.

HOW DOES THE INTELLIGENT SPEED LIMITER WORK

Intelligent speed limiter uses data from the traffic sign recognition system to set a maximum speed. For example, if the traffic sign recognition system detects a 80 km/h (50 mph) speed limit, the vehicle speed is limited to 80 km/h (50 mph).

INTELLIGENT SPEED LIMITER PRECAUTIONS



WARNING: When you are going downhill, your vehicle speed may increase above the set speed. The system will not apply the brakes but a warning displays. Failure to follow this warning could result in serious personal injury or death.



WARNING: You are responsible for controlling your vehicle at all times. The system is designed to be an aid and does not relieve you of your responsibility to drive with due care and attention. Failure to follow this instruction could result in the loss of control of your vehicle, personal injury or death.

Note: *The system does not limit your vehicle's speed to speed limits shown with a supplementary traffic sign.*

SWITCHING THE INTELLIGENT SPEED LIMITER ON AND OFF



Press to switch the system on.

The system activates with the detected speed limit or, if no speed limit is detected the current speed of your vehicle is set. Press again to switch the system off.

SETTING THE SPEED LIMIT



Press the toggle button upward or downward with the system in standby mode to set the speed limiter to the current vehicle speed. The set speed is stored and displayed in the instrument



cluster.

Note: *The set speed limiter adjusts when the system detects a different maximum speed limit.*

Note: *If the system cannot detect a maximum speed limit, the system returns to standby mode.*

CHANGING THE SET SPEED LIMIT



You can adjust the set speed in small or large increments. Press the toggle button upward or downward once to adjust the set speed in small increments. Press and hold the toggle button upward or downward to adjust the set speed in large increments.



Intelligent Speed Limiter

ADJUSTING THE SPEED LIMIT TOLERANCE

1.  Press the button on the touchscreen.
2. Press **Driver Assistance**.
3. Press **Speed Limit Assist**.
4. Switch **Intelligent Speed Limiter** on.
5. Use the slider bar to adjust the allowable tolerance for the system.

CANCELING THE SET SPEED LIMIT

 Press to cancel the limiter and place it in standby mode. The symbol in instrument cluster display appears grey.

RESUMING THE SET SPEED LIMIT

 Press to resume the limiter. The system sets the speed limit to the detected maximum speed limit when it resumes. The symbol in the instrument cluster display appears blue.

INTENTIONALLY EXCEEDING THE SET SPEED LIMIT

Firmly press the accelerator pedal to temporarily turn the system off. The system reactivates once your vehicle speed drops below the set speed.

INTELLIGENT SPEED LIMITER INDICATORS

 It illuminates in the instrument cluster when the system is in standby or active.

INTELLIGENT SPEED LIMITER AUDIBLE WARNINGS

A warning appears in the instrument cluster and a tone sounds if any of the following occur:

- Your vehicle's speed exceeds the current set speed.
- The system detects a maximum speed limit that is lower than your vehicle's current speed.
- You intentionally exceed the set speed.

If the traffic sign recognition system detects a speed limit outside the operational speed range, 20–180 km/h (12–112 mph), a single warning tone sounds and the system switches to standby mode.

SWITCHING FROM INTELLIGENT SPEED LIMITER TO SPEED LIMITER

1.  Press the button on the touchscreen.
2. Press **Driver Assistance**.
3. Press **Speed Limit Assist**.
4. Switch **Intelligent Speed Limiter** off.

Note: If you switch intelligent speed limiter off, the system defaults to manual speed limiter. You can manually set the speed limiter using the controls on the steering wheel.

Lane Keeping System

WHAT IS THE LANE KEEPING SYSTEM

The lane keeping system alerts you by providing temporary steering assistance or steering wheel vibration when it detects an unintended lane departure.

HOW DOES THE LANE KEEPING SYSTEM WORK

The lane keeping system uses a forward looking camera mounted on the windshield to monitor vehicle movement within the travel lane.

When the camera detects a drift out of the travel lane, the lane keeping system alerts the driver by vibrating the steering wheel, or aids the driver by providing a small steering input to move the vehicle back into the travel lane.

The driver can select one of three modes:

- Alert (If Equipped)
- Aid
- Alert + Aid

LANE KEEPING SYSTEM PRECAUTIONS

 **WARNING:** You are responsible for controlling your vehicle at all times. The system is designed to be an aid and does not relieve you of your responsibility to drive with due care and attention. Failure to follow this instruction could result in the loss of control of your vehicle, personal injury or death.

 **WARNING:** The system will not operate if the sensor cannot track the road lane markings.

 **WARNING:** The sensor may incorrectly track lane markings as other structures or objects. This can result in a false or missed warning.

 **WARNING:** In cold and severe weather conditions the system may not function. Rain, snow and spray can all limit sensor performance.

 **WARNING:** The system may not operate properly if the sensor is blocked. Keep the windshield free from obstruction.

 **WARNING:** If damage occurs in the immediate area surrounding the sensor, have your vehicle checked as soon as possible.

 **WARNING:** The system may not correctly operate if your vehicle is fitted with a suspension kit not approved by us.

 **WARNING:** Large contrasts in outside lighting can limit sensor performance.

LANE KEEPING SYSTEM LIMITATIONS

The lane keeping system only operates when the vehicle speed is greater than 64 km/h (40 mph).

The system works when the camera can detect at least one lane marking or the edge of the road.

The lane keeping system may not correctly operate in any of the following conditions:

- The lane keeping system does not detect at least one lane marking.
- You switch the turn signal on.

Lane Keeping System

- You apply direct steering, accelerate fast or brake hard.
- The vehicle speed is less than 64 km/h (40 mph).
- The anti-lock brake, stability control or traction control system activates.
- The lane is too narrow.
- Something is obscuring the camera or it is unable to detect the lane markings due to environment, traffic or vehicle conditions.

The lane keeping system may not correct lane positioning in any of the following conditions:

- High winds.
- Uneven road surfaces.
- Heavy or uneven loads.
- Incorrect tire pressure.

SWITCHING THE LANE KEEPING SYSTEM ON AND OFF



To activate the lane keeping system, press the button on the steering wheel.

To deactivate the lane keeping system, press the button on the steering wheel twice.

Note: When switching the system on or off a message appears in the information and entertainment display to show the status.

Note: The system always turns on when you start your vehicle.

SWITCHING THE LANE KEEPING SYSTEM MODE

The lane keeping system has different settings that you can view or adjust using the information display.

- Alert (If Equipped)
- Aid
- Alert and Aid

The system permanently stores the last known selection for each setting.

To change the lane keeping system mode:

1.  Press the button on the touchscreen.
2. Press **Driver Assistance**.
3. Press **Lane-Keeping System**.
4. Press **Lane-Keeping Mode**.
5. Select a setting.

Note: The system remembers the last setting when you start your vehicle.

LANE KEEPING SYSTEM SETTINGS

Adjusting the Steering Wheel Vibration Intensity

1.  Press the button on the touchscreen.
2. Press **Driver Assistance**.
3. Press **Lane-Keeping System**.
4. Press **Lane-Keeping Intensity**.
5. Select a setting.

Note: This setting is not available in all modes.

AID MODE

WHAT IS AID MODE

Aid mode provides temporary steering assistance toward the center of the lane.

Lane Keeping System

HOW DOES AID MODE WORK

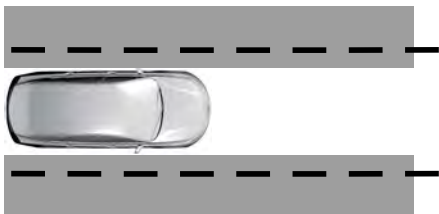

The lane keeping system aids you when an unintentional lane departure occurs. The system provides a small steering input to move the vehicle towards the center of the lane.

ALERT AND AID MODE

WHAT IS ALERT AND AID MODE

Alert and aid mode uses multiple features to keep you in your lane. The system first provides a small steering input to bring your vehicle back towards the center of the lane. If your vehicle moves too far out of the center of the lane the system alerts you with vibration in the steering wheel.

HOW DOES ALERT AND AID MODE WORK

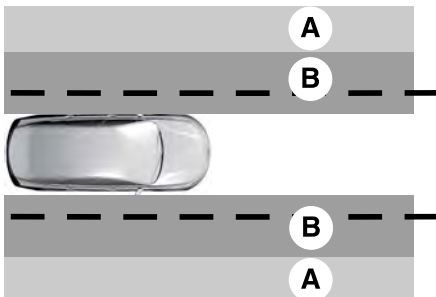

- A Alert.
- B Aid.

The lane keeping system detects a lane departure and provides aid when the vehicle enters **B** and applies the additional alert warning if **A** is entered.

LANE KEEPING SYSTEM INDICATORS



If you switch the lane keeping system on, a graphic with lane markings appears in the information display.

When you switch the system off, the lane marking graphics do not display.

Lane Keeping System

Note: *The overhead vehicle graphic may still display if adaptive cruise control is enabled.*

While the lane keeping system is on, the color of the lane markings change to indicate the system status.

Gray	Green	Yellow	Red
Indicates that the system is temporarily unavailable to provide a warning or intervention on the indicated side.	Indicates that the system is available or ready to provide a warning or intervention on the indicated side.	Indicates that the system is providing or has just provided a lane keeping aid intervention.	Indicates that the system is providing or has just provided a lane keeping alert warning.

BLIND SPOT ASSIST

WHAT IS BLIND SPOT ASSIST

Blind spot assist is an extension of the lane keeping system.

It may help you identify adjacent vehicles during a lane change.

Blind spot assist provides a blind spot warning and steering assistance to help during lane changes.

HOW DOES BLIND SPOT ASSIST WORK



Activate and deactivate the system using the lane keeping system button on the steering wheel.

During lane changes, the design of the blind spot assist feature detects vehicles in, or approaching, your blind spot and provides a warning, plus steering assistance to direct your vehicle back into your lane.

When active, this system functions with or without the use of turn signals and hazard flashers.

You must keep your hands on the steering wheel at all times.

BLIND SPOT ASSIST LIMITATIONS

All system limitations present in the basic lane keeping system also apply to blind spot assist.

Blind spot assist does not function under the following conditions:

- No lane markings are detected.
- One or both rear radar sensors become blocked or faulty.
- Attaching bike or cargo racks could cause false alerts due to obstruction of the sensor.

Blind spot assist may have difficulty detecting hazards under the following conditions:

- If a vehicle is approaching in an adjacent lane at a speed higher than your vehicle.
- Bad weather obstructing the sensors.

Lane Keeping System

BLIND SPOT ASSIST INDICATORS

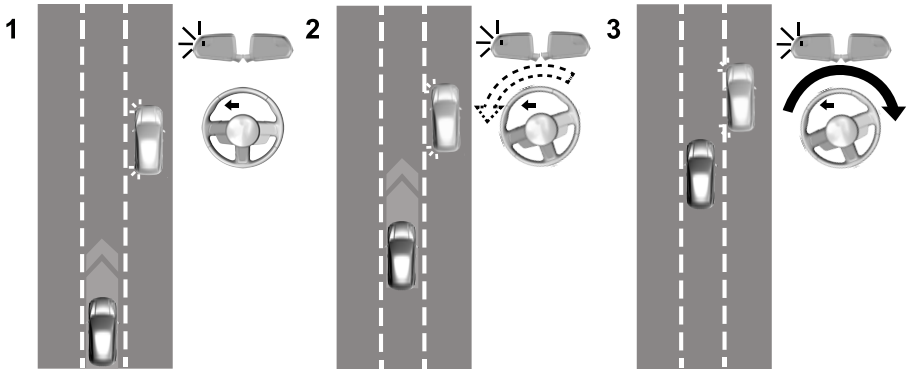

The lane keeping aid warning lamp or red lane marking in your instrument cluster display indicate blind spot assist activation. In addition, the blind spot information system alert indicator flashes on the exterior mirror on the same side as the detection. See **Blind Spot Information System** (page 272).

Lane Keeping System

LANE KEEPING SYSTEM – TROUBLESHOOTING

LANE KEEPING SYSTEM – INFORMATION MESSAGES

Message	Action
Lane keeping system malfunction Service required	The system has malfunctioned. Have your vehicle checked as soon as possible.
Front camera temporarily not available	The system has detected a condition that has caused the system to be temporarily unavailable.
Front camera Low visibility Clean screen	The system has detected a condition that requires you to clean the windshield in order for it to operate properly.
Front camera malfunction Service required	The system has malfunctioned. Have your vehicle checked as soon as possible.
Keep hands on steering wheel	The system requests that you keep your hands on the steering wheel.

Lane Keeping System

LANE KEEPING SYSTEM – FREQUENTLY ASKED QUESTIONS

Why is the feature not available (lane markings are gray) when I can see the lane markings on the road?
Your vehicle speed is less than 65 km/h (40 mph).
The sun is shining directly into the camera lens.
A quick intentional lane change has occurred.
Your vehicle stays too close to the lane markings for an extended interval of time.
Driving at high speeds in curves.
The last alert warning or aid intervention occurred a short time ago.
Ambiguous lane markings, for example, in construction zones.
Rapid transition from light to dark, or from dark to light.
Sudden offset in lane markings.
ABS or AdvanceTrac™ is active.
There is a camera blockage due to dirt, grime, fog, frost or water on the windshield.
You are driving too close to the vehicle in front of you.
Transitioning between no lane markings to lane markings, or vice versa.
There is standing water on the road.
Faint lane markings, for example, partial yellow lane markings on concrete roads.
Lane width is too narrow or too wide.
You have not calibrated the camera after a windshield replacement.
Driving on tight or on uneven roads.

Lane Keeping System

Why does the vehicle not come back toward the middle of the lane, as expected, in the Aid, or Aid + Alert mode?

High cross winds are present.

There is a large road crown.

Rough roads, grooves or shoulder drop-offs.

Heavy, uneven loading of the vehicle or improper tire inflation pressure.

You changed the tires or modified the suspension.

Blind Spot Information System

WHAT IS BLIND SPOT INFORMATION SYSTEM

Blind spot information system detects vehicles that may have entered the blind spot zone.

HOW DOES BLIND SPOT INFORMATION SYSTEM WORK

Blind spot information system uses sensors on both sides of your vehicle, detecting rearward from the exterior mirrors to approximately 4 m (13 ft) beyond the rear bumper. The detection area extends to approximately 18 m (59 ft) beyond the rear bumper when the vehicle speed is greater than 48 km/h (30 mph) to alert you of faster approaching vehicles.

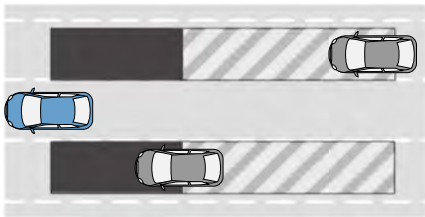

BLIND SPOT INFORMATION SYSTEM PRECAUTIONS

WARNING: Do not use the blind spot information system as a replacement for using the interior and exterior mirrors or looking over your shoulder before changing lanes. The blind spot information system is not a replacement for careful driving.



WARNING: The system may not operate properly during severe weather conditions, for example snow, ice, heavy rain and spray. Always drive with due care and attention. Failure to take care may result in a crash.

Note: *Blind spot information system does not prevent contact with other vehicles. It does not detect parked vehicles, pedestrians, animals or other infrastructure.*

BLIND SPOT INFORMATION SYSTEM LIMITATIONS

Blind spot information system does not operate in park (P) or reverse (R).

The system may not alert you if a vehicle quickly passes through the detection zone.

Note: *For vehicles without blind spot information system with trailer coverage, aftermarket trailer tow modules or tow bars may interfere with the system. In this situation it is recommended that you switch the system off when you attach a trailer. For vehicles with a trailer tow module and tow bar approved by the manufacturer, the system automatically turns off when you attach a trailer.*

BLIND SPOT INFORMATION SYSTEM REQUIREMENTS

Blind spot information system turns on when all the following occur:

- You start your vehicle.
- You shift into drive (D).
- The vehicle speed is greater than 10 km/h (6 mph).

Blind Spot Information System

SWITCHING BLIND SPOT INFORMATION SYSTEM ON AND OFF

-  Press the button on the touchscreen.
- Press **Driver Assistance**.
- Switch **BLIS** on or off.

Note: Some vehicles may not have the ability to switch the feature on or off.

When you switch blind spot information system off, a warning lamp illuminates. When you switch the system on or off, the alert indicators flash twice.

Note: The system remembers the last setting when you start your vehicle.

To permanently switch the system off, contact an authorized dealer.

LOCATING THE BLIND SPOT INFORMATION SYSTEM SENSORS

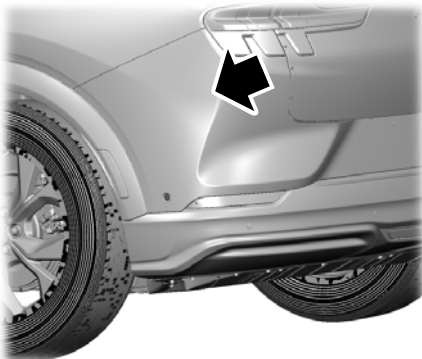

The sensors are behind the rear bumper on both sides of your vehicle.

Note: Keep the sensors free from snow, ice and large accumulations of dirt.

Note: Blocked sensors may affect system accuracy.

Note: Do not cover the sensors with bumper stickers, repair compound or other objects.

Note: Bike and cargo racks could cause false alerts due to obstruction of the sensor. We recommend switching the feature off when using a bike or cargo rack.

Note: The system may not correctly operate when towing a trailer. For vehicles with a trailer tow module and tow bar approved by us, the system turns off when you attach a trailer. For vehicles with an aftermarket trailer tow module or tow bar, we recommend that you switch the system off when you attach a trailer.

If the sensors become blocked, a message may appear in the instrument cluster display. See **Blind Spot Information System – Information Messages** (page 274). The alert indicators remain illuminated but the system does not alert you.

BLIND SPOT INFORMATION SYSTEM INDICATORS



Blind Spot Information System



When blind spot information system detects a vehicle, an alert indicator illuminates in the exterior mirror on the side the approaching

vehicle is coming from. If you turn the turn signal on for that side of your vehicle, the alert indicator flashes.

BLIND SPOT INFORMATION SYSTEM – TROUBLESHOOTING

BLIND SPOT INFORMATION SYSTEM – INFORMATION MESSAGES

Message	Action
BLIS malfunction	A fault with the system has occurred. Have your vehicle checked as soon as possible.
BLIS not available Sensor blocked See manual	Something is blocking the sensors. Clean the sensors.

Cross Traffic Alert

WHAT IS CROSS TRAFFIC ALERT

The system alerts you of vehicles approaching from the sides behind your vehicle when you shift into reverse (R).

HOW DOES CROSS TRAFFIC ALERT WORK

Cross traffic alert detects vehicles that approach at a speed between 6–60 km/h (4–37 mph). Coverage decreases when the sensors are partially, mostly or fully obstructed.

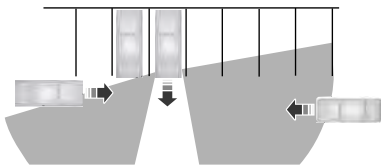

The sensor on the left-hand side is only partially obstructed and zone coverage on the right-hand side is maximized.

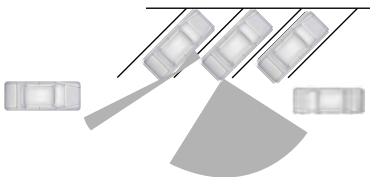

Zone coverage also decreases when parking at narrow angles. The sensor on the left-hand side is mostly obstructed and zone coverage on that side is severely reduced.

Note: *Slowly reversing helps increase the coverage area and effectiveness.*

CROSS TRAFFIC ALERT PRECAUTIONS



WARNING: Do not use the cross traffic alert system as a replacement for using the interior and exterior mirrors or looking over your shoulder before reversing out of a parking space. The cross traffic alert system is not a replacement for careful driving.



WARNING: The system may not operate properly during severe weather conditions, for example snow, ice, heavy rain and spray. Always drive with due care and attention. Failure to take care may result in a crash.

CROSS TRAFFIC ALERT LIMITATIONS

Cross traffic alert may not correctly operate when any of the following occur:

- Something is blocking the sensors.
- Adjacently parked vehicles or objects are obstructing the sensors.
- Vehicles approach at speeds less than 6 km/h (4 mph) or greater than 60 km/h (37 mph).
- Your vehicle speed is greater than 12 km/h (7 mph).
- You reverse out of an angled parking space.

SWITCHING CROSS TRAFFIC ALERT ON AND OFF

1.



Press the button on the touchscreen.

2. Press **Driver Assistance**.

Cross Traffic Alert

3. Switch **Cross Traffic Alert** on or off.

When you switch the system on or off, the alert indicators flash twice.

Note: The system turns on every time you start your vehicle. To permanently switch the system off, contact an authorized dealer.

LOCATING THE CROSS TRAFFIC ALERT SENSORS

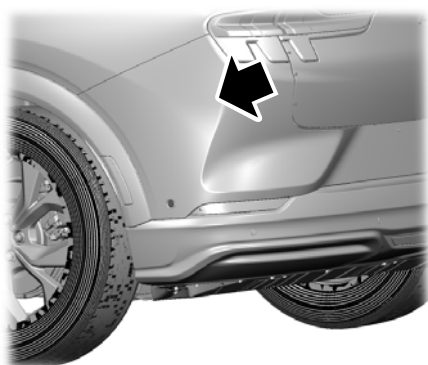

The sensors are behind the rear bumper on both sides of your vehicle.

Note: Keep the sensors free from snow, ice and large accumulations of dirt.

Note: Do not cover the sensors with bumper stickers, repair compound or other objects.

Note: Blocked sensors may affect system accuracy.

Note: Bike and cargo racks could cause false alerts due to obstruction of the sensor. We recommend switching the feature off when using a bike or cargo rack.

If something is blocking the sensors, a message may appear in the information display when you shift into reverse (R).

CROSS TRAFFIC ALERT INDICATORS



When the cross traffic alert detects an approaching vehicle, a tone sounds, a warning lamp illuminates in the relevant exterior mirror and arrows appear in the information display to show which side the vehicle is approaching from.

If the system malfunctions, a warning lamp illuminates in the instrument cluster and a message appears in the instrument cluster display. Have your vehicle checked as soon as possible.

Note: If arrows do not display, a message appears in the instrument cluster display.

Note: In some conditions, the system could alert you, even when there is nothing in the detection zone, for example a vehicle passing further away from your vehicle.

Cross Traffic Alert

CROSS TRAFFIC ALERT – TROUBLESHOOTING

CROSS TRAFFIC ALERT – INFORMATION MESSAGES

Message	Action
Cross traffic alert	Displays instead of indication arrows when the system detects a vehicle. Check for approaching traffic.
Cross Traffic not available Sensor blocked See manual	Indicates blocked cross traffic alert system sensors. Clean the sensors. If the message continues to appear, have your vehicle checked as soon as possible.
Cross traffic system malfunction	The system has malfunctioned. Have your vehicle checked as soon as possible.

Pre-Collision Assist

WHAT IS PRE-COLLISION ASSIST

Pre-collision assist detects and warns of approaching hazards in the roadway. If your vehicle is rapidly approaching another stationary vehicle, a vehicle traveling in the same direction as yours, or a pedestrian within your driving path, the system provides multiple levels of assistance to help avoid a collision.

HOW DOES PRE-COLLISION ASSIST WORK

The system warns the driver of potential hazards by providing three levels of assistance.



If your vehicle is rapidly approaching potential hazards the system provides the following levels of functionality:

1. Alert.
2. Brake Support.
3. Automatic Emergency Braking.



Alert: When active, a flashing visual warning appears and an audible warning tone sounds.

Brake Support: The system is designed to help reduce the impact speed by preparing the brakes for rapid braking. The system does not automatically apply the brakes. If you press the brake pedal, the system could apply additional braking up to maximum braking force, even if you lightly press the brake pedal.

Automatic Emergency Braking: Automatic emergency braking may activate if the system determines that a collision is imminent.

Note: If you perceive the pre-collision assist alerts as being too frequent or disturbing, then you can reduce the alert sensitivity. Setting the low sensitivity would result in fewer and later warnings of a potential forward collision. The manufacturer recommends using the high sensitivity setting where possible.

Note: Automatic emergency braking performance is not affected by the sensitivity setting.

Each system has various levels of detection capabilities. See **Pre-Collision Assist Limitations** (page 279).

PRE-COLLISION ASSIST PRECAUTIONS



WARNING: You are responsible for controlling your vehicle at all times. The system is designed to be an aid and does not relieve you of your responsibility to drive with due care and attention. Failure to follow this instruction could result in the loss of control of your vehicle, personal injury or death.



WARNING: The system does not detect vehicles moving in a different direction or animals. Apply the brakes when necessary. Failure to follow this instruction could result in the loss of control of your vehicle, personal injury or death.



WARNING: The system does not operate during hard acceleration or steering. Failure to take care may lead to a crash or personal injury.

Pre-Collision Assist



WARNING: The system may operate with reduced function during cold and inclement weather conditions. Snow, ice, rain, spray and fog can adversely affect the system. Keep the front camera and radar free of snow and ice. Failure to follow this instruction may result in the loss of control of your vehicle, serious personal injury or death.



WARNING: Take additional care if your vehicle is heavily loaded or you are towing a trailer. These conditions could result in reduced performance of this system. Failure to follow this instruction could result in the loss of control of your vehicle, personal injury or death.



WARNING: The system cannot help prevent all crashes. Do not rely on this system to replace driver judgment and the need to maintain a safe distance and speed.



WARNING: System performance could be reduced in situations where the vehicle camera has limited detection capability. These situations include but are not limited to direct or low sunlight, vehicles at night without tail lights, unconventional vehicle types, pedestrians or cyclists with complex backgrounds, running pedestrians or fast moving cyclists, partly obscured pedestrians or cyclists, pedestrians or cyclists that the system cannot distinguish from a group. Failure to take care may result in the loss of control of your vehicle, personal injury or death.

PRE-COLLISION ASSIST LIMITATIONS

Pre-collision assist depends on the detection ability of its camera and sensors. Any obstructions or damage to these areas can limit detection or prevent the system from functioning. See **Locating the Pre-Collision Assist Sensors** (page 280).

The system is active at 5 km/h (3 mph) and above.

Note: *Brake support and automatic emergency braking are active up to the maximum speed of the vehicle.*

Pedestrian Detection Limitations

Pedestrian detection is active at speeds up to 80 km/h (50 mph).

Pedestrian detection functions optimally when detected hazards are clearly identifiable. System performance may reduce in situations where pedestrians are running, partly obscured, have a complex background, or cannot be distinguished from a group.

Cyclist Detection Limitations

Cyclist detection is active at speeds up to 80 km/h (50 mph).

Cyclist detection functions optimally when detected hazards are clearly identifiable. The system's detection level may be less in situations where cyclists are moving fast, partly hidden, have a complex background, or the system cannot distinguish the cyclist from a group.

Pre-Collision Assist

Intersection Assist

The pre-collision assist system may operate in a scenario where you are turning across an oncoming vehicle's path. Detection of vehicles driving in an oncoming direction is active if your vehicle is driving at speeds up to 80 km/h (50 mph).

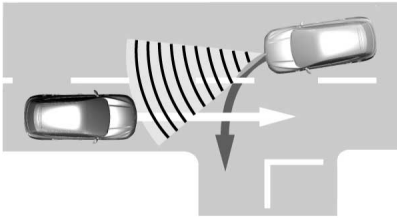

SWITCHING PRE-COLLISION ASSIST ON AND OFF

You cannot switch the system off.

Adjusting the Pre-Collision Assist Settings

You can adjust the following settings by using the controls in the pre-collision assist menu:

- Change alert and distance alert sensitivity to one of three possible settings.
- Switch distance indication and alert on or off.
- If required, switch automatic emergency braking on or off.
- If required, switch evasive steering assist on or off.

Note: Automatic emergency braking and evasive steering automatically turns on every time you switch the ignition on.

Note: If you switch automatic emergency braking off, evasive steering assist switches off.

LOCATING THE PRE-COLLISION ASSIST SENSORS

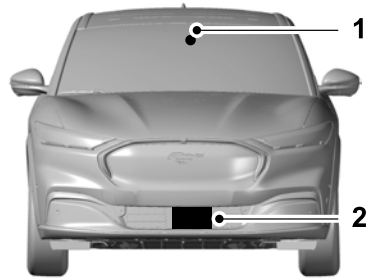

1. Camera.
2. Radar sensor.

If a message regarding a blocked sensor or camera appears in the information display, something is obstructing the radar signals or camera images. The radar sensor is behind the fascia cover in the center of the lower grille. With a blocked sensor or camera, the system may not function, or performance may reduce. See **Pre-Collision Assist – Information Messages** (page 284).

Note: Proper system operation requires a clear view of the road by the camera. Repair any windshield damage in the area of the camera's field of view.

Note: If something hits the front end of your vehicle or damage occurs and your vehicle has a radar sensor, the radar sensing zone could change. This could cause missed or false vehicle detections. Have your vehicle serviced to have the radar checked for proper coverage and operation.

Pre-Collision Assist

Note: If your vehicle detects excessive heat at the camera or a potential misalignment condition, a message could display in the information display indicating temporary sensor unavailability. When operational conditions are correct, the message deactivates. For example, when the ambient temperature around the sensor decreases or the sensor recalibrates successfully.

DISTANCE INDICATION

WHAT IS DISTANCE INDICATION

Distance indication displays the gap between your vehicle and the vehicle ahead of you.

Note: The graphic does not display if you switch on cruise control or adaptive cruise control.

Vehicle Speed	System Sensitivity	Distance Indicator Color	Distance Gap	Time Gap
100 km/h (62 mph).	Normal.	Blue.	Greater than 25 m (82 ft).	Greater than 0.9 seconds.
		Yellow.	17–25 m (56–82 ft).	0.6–0.9 seconds.
		Red.	Less than 17 m (56 ft).	Less than 0.6 seconds.

Pre-Collision Assist

SWITCHING DISTANCE INDICATION ON AND OFF

1.  Press the button on the touchscreen.
2. Press **Driver Assistance**.
3. Press **Pre-Collision Assist**.
4. Switch **Distance indication** on or off.

DISTANCE INDICATION INDICATOR

The indicator displays the time gap between your vehicle and vehicles traveling in the same direction ahead of you.

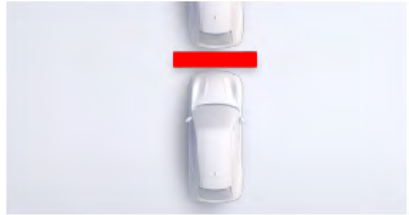

DISTANCE ALERT

WHAT IS DISTANCE ALERT

The system alerts you with a warning lamp if the distance to the vehicle ahead is small.

Note: *The warning lamp does not illuminate if cruise control or adaptive cruise control is active.*

ADJUSTING THE SENSITIVITY OF DISTANCE ALERT

To adjust the sensitivity of the system:

Pre-Collision Assist

-  Press the button on the touchscreen.
- Press **Driver Assistance**.
- Press **Pre-Collision Assist**.
- Press **Alert sensitivity**.
- Select a setting.

AUTOMATIC EMERGENCY BRAKING

WHAT IS AUTOMATIC EMERGENCY BRAKING

Automatic emergency braking may activate if the system determines that a collision is imminent. The system may help reduce impact damage to avoid the crash completely.

Automatic emergency braking is only available up to certain speeds. See **Pre-Collision Assist Limitations** (page 279).

SWITCHING AUTOMATIC EMERGENCY BRAKING ON AND OFF

-  Press the button on the touchscreen.
- Press **Driver Assistance**.
- Press **Pre-Collision Assist**.
- Switch **Automatic Emergency Braking** on or off.

EVASIVE STEERING ASSIST

WHAT IS EVASIVE STEERING ASSIST

If your vehicle is rapidly approaching a road user, evasive steering assist helps you steer around the road user.

After you turn the steering wheel in an attempt to avoid a crash with the road user, the system applies additional steering torque to help you steer around the road user. After you pass the road user, the system applies steering torque when you turn the steering wheel to steer back into the lane. The system deactivates after you fully pass the road user.

Note: *Road users are defined as pedestrians or bicyclists in your vehicle's path or another stationary vehicle in the same lane or a vehicle traveling in the same lane in the same direction as you. See **Pre-Collision Assist Precautions** (page 278).*

EVASIVE STEERING ASSIST LIMITATIONS

Evasive steering assist only activates when all the following occur:

- Automatic emergency braking and evasive steering assist are on.
- The system detects a road user ahead and starts to apply the brakes.
- You significantly turn the steering wheel to steer around a road user.

Note: *Evasive steering assist does not automatically steer around a road user. If you do not turn the steering wheel, evasive steering assist does not activate.*

Note: *Evasive steering assist does not activate if the distance to the road user ahead is too small and the system cannot avoid a crash.*

Pre-Collision Assist

SWITCHING EVASIVE STEERING ASSIST ON AND OFF

1.  Press the button on the touchscreen.
2. Press **Driver Assistance**.
3. Press **Pre-Collision Assist**.
4. Switch **Evasive Steering** on or off.

Note: If you switch automatic emergency braking off, evasive steering assist turns off.

Note: Automatic emergency braking and evasive steering assist turn on every time you switch the power on.

PRE-COLLISION ASSIST – TROUBLESHOOTING

PRE-COLLISION ASSIST – WARNING LAMPS



A telltale illuminates in the cluster to indicate if the system is disabled or unavailable.

PRE-COLLISION ASSIST – INFORMATION MESSAGES

Message	Action
Pre-collision assist not available Sensor blocked	You have a blocked sensor due to bad weather, ice, mud or water in front of the radar sensor. You can typically clean the sensor to resolve.
Pre-collision assist not available	A fault with the system has occurred. Have your vehicle checked as soon as possible.

Pre-Collision Assist

PRE-COLLISION ASSIST – FREQUENTLY ASKED QUESTIONS

Camera Troubleshooting

The windshield in front of the camera is dirty or obstructed.

Clean the outside of the windshield in front of the camera.

The windshield in front of the camera is clean, but the message remains in the instrument cluster display.

Wait a short time. It could take several minutes for the camera to detect that there is no obstruction.

Radar Troubleshooting

The surface of the radar in the grille is dirty or obstructed.

Clean the grille surface in front of the radar or remove the object causing the obstruction.

The surface of the radar in the grille is clean, but the message remains in the instrument cluster display.

Wait a short time. It could take several minutes for the radar to detect that there is no obstruction.

Heavy rain, spray or fog is interfering with the radar signals.

The pre-collision assist system is temporarily disabled. Pre-collision assist reactivates a short time after the weather conditions improve.

Swirling water or snow or ice on the surface of the road is interfering with the radar signals.

The pre-collision assist system is temporarily disabled. Pre-collision assist reactivates a short time after the weather conditions improve.

Radar is out of alignment due to a front end impact.

Have your vehicle serviced to have the radar checked for proper coverage and operation.

Driver Alert

WHAT IS DRIVER ALERT

Driver alert alerts you if it determines that you are becoming drowsy or if your driving deteriorates.

HOW DOES DRIVER ALERT WORK

Driver Alert calculates your alertness level based on your driving behavior in relation to the lane markings and other factors through use of the front camera sensor behind the interior mirror.

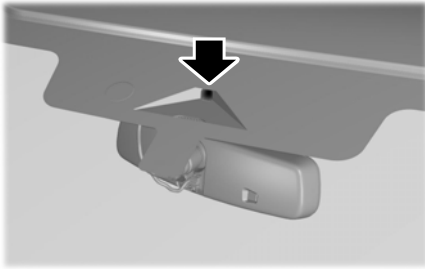

DRIVER ALERT PRECAUTIONS

WARNING: You are responsible for controlling your vehicle at all times. The system is designed to be an aid and does not relieve you of your responsibility to drive with due care and attention. Failure to follow this instruction could result in the loss of control of your vehicle, personal injury or death.

WARNING: Take regular rest breaks if you feel tired. Do not wait for the system to warn you.

WARNING: Certain driving styles may result in the system warning you even if you are not feeling tired.

WARNING: In cold and severe weather conditions the system may not function. Rain, snow and spray can all limit sensor performance.

WARNING: The system will not operate if the sensor cannot track the road lane markings.

WARNING: If damage occurs in the immediate area surrounding the sensor, have your vehicle checked as soon as possible.

WARNING: The system may not correctly operate if your vehicle is fitted with a suspension kit not approved by us.

WARNING: The system may not operate properly if the sensor is blocked. Keep the windshield free from obstruction.

Note: If something is blocking the camera or damaged the windshield, Driver Alert may not function.

DRIVER ALERT LIMITATIONS

Driver alert may not function correctly if:

- The sensor cannot track the road lane markings.
- Your vehicle's speed is less than approximately 65 km/h (40 mph).

Driver Alert

SWITCHING DRIVER ALERT ON AND OFF

-  Press the button on the touchscreen.
- Press **Driver Assistance**.
- Switch **Driver Alert** on or off.

Note: *The system remains on or off depending on how it was last set.*

Resetting Driver Alert

You can reset the system by either:

- Switching the ignition off and on.
- Stopping the vehicle and then opening and closing the driver door.

DRIVER ALERT – TROUBLESHOOTING

DRIVER ALERT – INFORMATION MESSAGES

Message	Action
Driver fatigue warning Rest now	Stop and rest as soon as it is safe to do so.
Driver fatigue warning Rest suggested	Take a rest soon.

DRIVER ALERT INDICATORS

System Warnings

The warning system has two stages:

- A temporary warning is issued to advise you to take a rest. This message only appears for a short time.
- If you do not rest and the system continues to detect that your driving deteriorates, it issues a further warning. This remains in the instrument cluster display until you cancel it.

Note: *The system does not warn you if the vehicle speed falls below approximately 65 km/h (40 mph).*

Traffic Sign Recognition

WHAT IS TRAFFIC SIGN RECOGNITION

Traffic sign recognition detects traffic signs to inform you of the current speed limit and traffic conditions. Detected signs appear in the instrument cluster display.

HOW DOES TRAFFIC SIGN RECOGNITION WORK

Traffic sign recognition uses a sensor behind the interior mirror to detect traffic signs.

If your vehicle has a navigation system, stored traffic sign data could influence the indicated speed limit value.

The system detects recognizable traffic signs, for example:

- Speed limit signs.
- No overtaking signs.
- Speed limit cancellation signs.
- No overtaking cancellation signs.

TRAFFIC SIGN RECOGNITION PRECAUTIONS



WARNING: You are responsible for controlling your vehicle at all times. The system is designed to be an aid and does not relieve you of your responsibility to drive with due care and attention. Failure to follow this instruction could result in the loss of control of your vehicle, personal injury or death.



WARNING: In cold and severe weather conditions the system may not function. Rain, snow and spray can all limit sensor performance.



WARNING: The system may not operate properly if the sensor is blocked. Keep the windshield free from obstruction.



WARNING: The system may not operate properly if your vehicle has a non-Ford windshield. Do not carry out windshield repairs in the area around the sensor.

Note: Always replace headlamp bulbs and other bulbs with parts that meet the specifications for your vehicle. Non-standard parts could reduce system performance.

Note: If your vehicle has a suspension kit not approved by Ford, the system may not correctly function.

TRAFFIC SIGN RECOGNITION LIMITATIONS

Traffic sign recognition may not operate correctly due to the following:

- Outdated map data.
- Incorrect recognition of traffic signs by the sensor of signs on parallel roads or exit ramps.
- Missed recognition of faded, dirty or distorted signs.

Note: The system may not detect all speed and traffic signs and may incorrectly read signs.

Traffic Sign Recognition

TRAFFIC SIGN RECOGNITION INDICATORS



Traffic sign recognition can display two traffic signs together.

Note: Sign indicator image may vary based on your vehicle's display type.

SETTING THE TRAFFIC SIGN RECOGNITION SPEED WARNING

1.  Press the button on the touchscreen.
2. Press **Driver Assistance**.
3. Press **Speed Limit Assist**.
4. Switch the speed warning on or off.

SETTING THE TRAFFIC SIGN RECOGNITION SPEED TOLERANCE

To set the tolerance of the speed warning, use the touchscreen.

1.  Press the button on the touchscreen.
2. Press **Driver Assistance**.
3. Press **Speed Limit Assist**.

4. Press **Tolerance**.
5. Use the slider bar to select the required level.

TRAFFIC SIGN RECOGNITION – TROUBLESHOOTING

TRAFFIC SIGN RECOGNITION – INFORMATION MESSAGES

Message	Action
Traffic sign recognition Reduced performance See manual	The traffic sign data provided by the navigation system is unavailable due to weak or no signal. Wait a short period of time for the signal to improve. If the message continues to appear, have the system checked as soon as possible.

TRAFFIC SIGN RECOGNITION – FREQUENTLY ASKED QUESTIONS

Why does the speed limit or traffic sign change without any sign on the road?

The speed limit and traffic sign changes due to stored data in the map data.

Why does traffic sign recognition show a wrong sign?

The system shows a wrong sign due to incorrect and outdated map data or due to incorrect recognition of the signs by the camera.

Wrong Way Alert

WHAT IS WRONG WAY ALERT

The system alerts you if it detects that you are driving the wrong way on a freeway exit road.

HOW DOES WRONG WAY ALERT WORK

Wrong way alert uses a sensor behind the interior mirror to detect no entry signs and uses information from the navigation system.

Note: *Traffic sign data provided by the navigation system contains information integrated into the data carrier release.*

WRONG WAY ALERT PRECAUTIONS



WARNING: You are responsible for controlling your vehicle at all times. The system is designed to be an aid and does not relieve you of your responsibility to drive with due care and attention. Failure to follow this instruction could result in the loss of control of your vehicle, personal injury or death.



WARNING: The system may not operate properly if the sensor is blocked. Keep the windshield free from obstruction.



WARNING: The system may not operate properly during severe weather conditions, for example snow, ice, heavy rain and spray. Always drive with due care and attention. Failure to take care may result in a crash.



WARNING: The system may not operate properly if your vehicle has a non-Ford windshield. Do not carry out windshield repairs in the area around the sensor.

Note: *Always replace headlamp bulbs with those specifically designed for your vehicle. Other bulbs may reduce system performance.*

Note: *If your vehicle has a suspension kit not approved by us, the system may not correctly function.*

Note: *In exceptional conditions, the system could alert you even if you are not driving the wrong way on a freeway exit road.*

WRONG WAY ALERT LIMITATIONS

The system may not detect all traffic signs and may incorrectly read signs. It is designed to detect traffic signs that meet the Vienna convention.

The system does not operate in some countries. Check the systems availability before use.

The system may not correctly operate in areas under construction or new infrastructure.

SWITCHING WRONG WAY ALERT ON AND OFF

-  Press the button on the touchscreen.
- Press **Driver Assistance**.
- Switch the feature on or off.

Wrong Way Alert

WRONG WAY ALERT – TROUBLESHOOTING

WRONG WAY ALERT – INFORMATION MESSAGES

If the system detects that you are driving the wrong way on a freeway exit road, a message appears in the instrument cluster and a tone sounds. The audio system volume mutes and the navigation system guidance pauses.

Message	Action
Check driving direction	The system detects that you are driving the wrong way on a freeway exit road. Ensure you are driving in the correct direction.

Load Carrying

DOG GUARD

INSTALLING THE DOG GUARD BEHIND THE FRONT SEATS

A dog guard compliant to ISO 27955 is available as an aftermarket accessory from our authorized dealers.

INSTALLING THE DOG GUARD BEHIND THE REAR SEATS

A dog guard compliant to ISO 27955 is available as an aftermarket accessory from our authorized dealers.

LOAD CARRYING PRECAUTIONS

 **WARNING:** Make sure that you properly secure objects in the luggage compartment. Failure to follow this instruction could result in personal injury in the event of a sudden stop or crash.

 **WARNING:** Do not place objects on the luggage cover. Failure to follow this instruction could result in personal injury or death in the event of a sudden stop or crash.

 **WARNING:** The appropriate loading capacity of your vehicle can be limited either by volume capacity (how much space is available) or by payload capacity (how much weight the vehicle should carry). Once you have reached the maximum payload of your vehicle, do not add more cargo, even if there is space available. Overloading or improperly loading your vehicle can contribute to loss of vehicle control and vehicle rollover.

 **WARNING:** Do not exceed the maximum front and rear axle loads for your vehicle.

Note: *When loading long objects into your vehicle, for example, pipes, timber or furniture, be careful not to damage the interior trim.*

ROOF RACK

ROOF RACK PRECAUTIONS

 **WARNING:** Read and follow the manufacturer's instructions when you are fitting a roof rack.

 **WARNING:** When loading the roof racks, we recommend you evenly distribute the load, as well as maintain a low center of gravity. Loaded vehicles, with higher centers of gravity, may handle differently than unloaded vehicles. Take extra precautions, such as slower speeds and increased stopping distance, when driving a heavily loaded vehicle.

 **WARNING:** Do not switch off stability control or use Sport or Track mode when carrying a roof load. This could lead to an increased risk of loss of vehicle control, vehicle rollover, personal injury or death.

Note: *If you use a roof rack, the energy consumption of your vehicle will be higher and you may experience different driving characteristics.*

Note: *Never place loads directly on the roof panel. The roof panel is not designed to directly carry a load.*

Load Carrying

You must place loads directly on the crossbars. When using the roof rack system, we recommend that you use genuine Ford accessory crossbars

specifically designed for your vehicle.

Make sure that you securely fasten the load. Check the tightness of the load before driving and at each charge stop.

ROOF RACK LOAD CAPACITIES

Description	Maximum Recommended Load
Vehicles with a moonroof.	65 kg (145 lb)
Vehicles without a moonroof.	75 kg (165 lb)

Note: *The maximum roof load is based on evenly distributing the load on the crossbars.*

Note: *When using a roof rack system, subtract the weight of the roof rack system from the maximum recommended load to determine your actual maximum cargo load. See the roof rack system manufacturer for more information.*

TOW BAR MOUNTED CARRIER

TOW BAR MOUNTED CARRIER PRECAUTIONS



WARNING: Do not exceed the lowest rating capacity for your vehicle or trailer hitch. Overloading your vehicle or trailer hitch can impair your vehicle stability and handling. Failure to follow this instruction could result in the loss of control of your vehicle, personal injury or death.



WARNING: Cargo accessory devices mounted to the hitch can change the weight distribution of the vehicle. Loaded vehicles, with more rear weight, may handle differently than unloaded vehicles. Take extra precautions, such as slower speeds and increased stopping distance, when driving a heavily loaded vehicle.

When using a tow bar mounted carrier, consider the following:

- Carefully follow the instructions and warnings provided by the manufacturer of any cargo carrying device.
- Before driving the vehicle, make sure to properly attach the cargo carrying device, and securely attach all equipment to the cargo carrying device.
- When loading a cargo accessory device to the hitch, do not exceed the maximum gross vehicle weight or maximum front and rear axle weights on the vehicle as defined on the vehicle identification plate. Mounting cargo accessory devices to the hitch limits the passenger and cargo capacity inside the vehicle.

Load Carrying

- If you are using a bike carrier, the maximum allowed weight is 75 kg (165 lb).
- Load the heaviest item closest to your vehicle.

TOW BAR MOUNTED LOAD CAPACITIES

The maximum accessory hitch load for cargo carrying devices is 75 kg (165.35 lb) unless restricted by lower hitch capacity or cargo carrying device capacity. We recommend using a hitch authorized by us which meets these load requirements. Do not exceed any certified vehicle loads as defined on the Vehicle Identification Plate.

Luggage Compartment

LUGGAGE COMPARTMENT PRECAUTIONS



WARNING: Keep vehicle doors and luggage compartment locked and keep keys and remote transmitters out of a child's reach. Unsupervised children could lock themselves in the luggage compartment and risk injury. Children should be taught not to play in vehicles.

Note: The frunk only operates when the vehicle is in park (P). If there is a problem with the open or close request, a tone sounds and a warning message appears in the instrument cluster.

Note: Do not hang any weight from the frunk. This could damage the frunk and its components. Remove any excessive weight from the frunk prior to use. If the frunk starts to close after it has fully opened, this indicates there may be excessive weight on the frunk or a possible strut failure. A repetitive tone sounds and the frunk closes under control. If the frunk continues to close after opening, have the system checked.

Note: Do not leave the frunk open while driving. This could damage the frunk and its components.

OPENING THE FRUNK

OPENING THE FRUNK FROM INSIDE YOUR VEHICLE

[Discovering Mustang Mach-E Cargo Spaces Video Link](#)

Note: Make sure the vehicle is in park (P).

Using the Touchscreen

-  Press the button on the touchscreen.
- Press **CONTROLS**.
-  Press the front luggage compartment icon.

Manually Opening the Frunk



E263274

- Open the left-hand front door.
- Pull the release lever to release the primary latch.
- Pull the release lever a second time to release the frunk.
- Lift the frunk. The struts support the frunk.

OPENING THE FRUNK FROM OUTSIDE YOUR VEHICLE

Note: Be careful when opening the frunk in a garage or other enclosed area to avoid damaging the frunk.

Luggage Compartment

Using the Keyless Entry Keypad

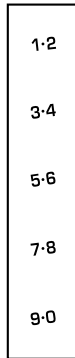

Enter the factory set code or your personal code, then press **7-8** on the keypad within five seconds.

Using Phone as a Key (If Equipped)

Press the button to open the frunk.

Note: Make sure the authorized phone is within 1 m (3 ft) of the vehicle.

OPENING THE FRUNK USING THE REMOTE CONTROL



Press the button twice within three seconds.

Note: Be careful when opening the frunk in a garage or other enclosed area to avoid damaging the frunk.

CLOSING THE FRUNK

CLOSING THE FRUNK FROM OUTSIDE YOUR VEHICLE

Manually Closing the Frunk



WARNING: People should never climb inside the luggage compartment. Never shut the luggage compartment when a person is inside.

Lower the frunk and apply light pressure as it drops.

Note: Before driving off, check the instrument cluster for a frunk ajar message or warning indicator. Failure to do this could result in unintentionally leaving the frunk open while driving.

USING THE FRUNK EMERGENCY RELEASE



Luggage Compartment

If you are stuck inside the trunk, press the interior release button to open it. The material around the switch glows after a brief exposure to ambient light.

INSTALLING AND REMOVING THE LUGGAGE COMPARTMENT CARGO NET

The anchor points are located behind the second row seats.

INSTALLING AND REMOVING THE LUGGAGE COMPARTMENT COVER

Remove the front luggage compartment covers in the following order:

1. Rear cover.
2. Left-hand side cover.
3. Right-hand side cover.

Removing the Rear Cover

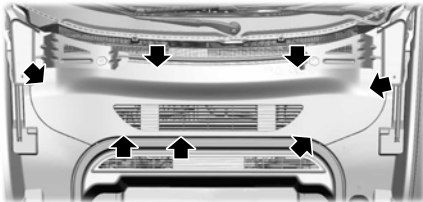

1. Start at the rear edge of the left-hand side.
2. Pull upward at the clip locations shown to release the clips.
3. Carefully remove the cover.
4. To install, reverse the removal procedure.

Removing the Left-Hand Side Cover

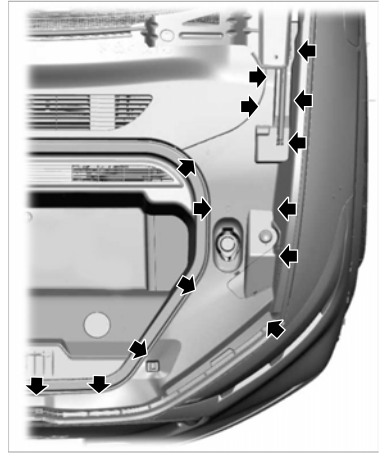

1. Start at the rear edge of the left-hand side and work toward the front of the cover.
2. Pull upward at the clip locations shown to release the clips.
3. Carefully remove the cover.
4. To install, reverse the removal procedure.

Luggage Compartment

Removing the Right-Hand Side Cover



1. Start at the rear edge of the right-hand side and work toward the front of the cover.
2. Pull upward at the clip locations shown to release the clips.
3. Carefully remove the cover.
4. To install, reverse the removal procedure.

ADJUSTING THE LUGGAGE COMPARTMENT LOAD FLOOR

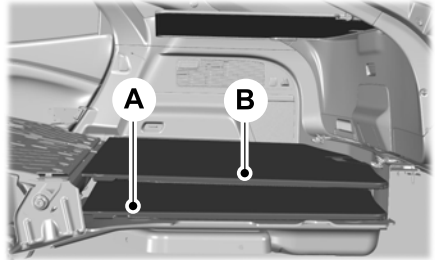

- A Low load floor position.
B High load floor position.

The load floor can be adjusted to a higher position to provide a flat load area when the rear seats are folded.

LUGGAGE COMPARTMENT ANCHOR POINTS

LOCATING THE LUGGAGE COMPARTMENT ANCHOR POINTS

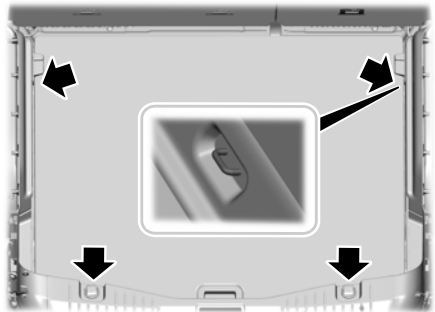

Luggage Compartment

The anchor points for the rear luggage compartment are located behind the rear seats.

LUGGAGE COMPARTMENT – TROUBLESHOOTING

LUGGAGE COMPARTMENT – WARNING LAMPS



Illuminates when the the ignition is on and the frunk is not completely closed.

Connecting a Trailer

TOW BALL

TOW BALL PRECAUTIONS



WARNING: Do not exceed the lowest rating capacity for your vehicle or trailer hitch. Overloading your vehicle or trailer hitch can impair your vehicle stability and handling. Failure to follow this instruction could result in the loss of control of your vehicle, personal injury or death.



WARNING: Do not cut, drill, weld or modify the trailer hitch. Modifying the trailer hitch could reduce the hitch rating.



WARNING: Always place the tow ball arm in a secure location in your vehicle so it does not become a projectile in a crash. Failure to follow this instruction could result in personal injury or death.

Tow Ball Arm Guidelines

- Replacement keys are available. We recommend that you record the key number on the lock cylinder.
- The tow ball arm mechanism is maintenance free. Do not grease or oil the mechanism.

- Remove the trailer wiring plug from the trailer wiring connection socket when not in use. Failure to do so may result in corrosion of the trailer wiring connection socket. Regularly clean the trailer wiring connection socket and make sure the socket cover is fully closed.
- If you use a high pressure water jet to clean your vehicle, disconnect the trailer wiring plug. Do not aim the water jet directly at the trailer wiring connection socket. We recommend that you detach the tow ball arm before washing your vehicle.

DETACHING THE TOW BALL ARM

You must detach the tow ball arm when not in use. Securely stow the tow ball arm in the luggage compartment.

Never unlock or detach the tow ball arm with a trailer attached.

Do not use any tools to detach the tow ball arm.

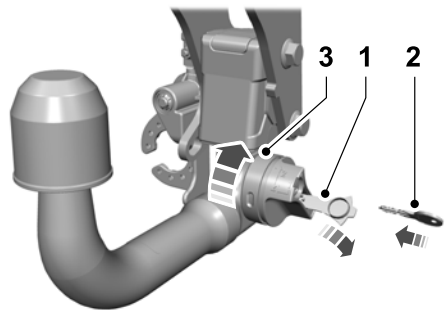

1. Remove the protective cap.
2. Insert the key and turn it counterclockwise to unlock the handwheel.

Connecting a Trailer

3. Hold the tow ball arm. Push the handwheel inward and turn it clockwise.

Note: *The mark on the handwheel turns from green to red.*

4. Release the handwheel.
5. Pull the tow ball arm downward to remove it.
6. Turn the trailer wiring connection socket upward through 90° until it engages in the end position.

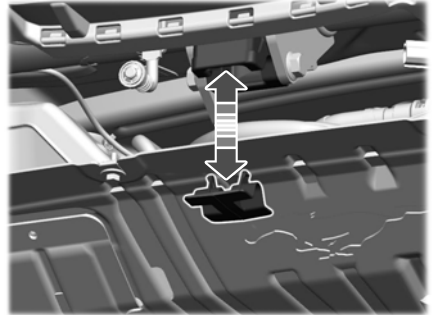
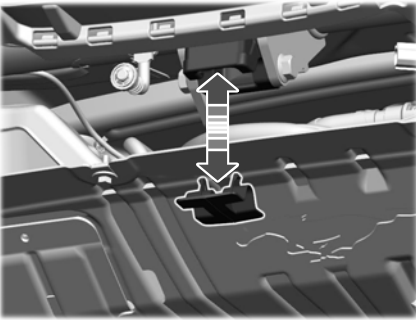

1. Remove the blanking plug.

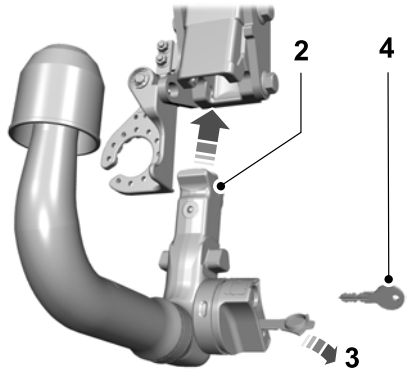

7. Insert the blanking plug.

ATTACHING THE TOW BALL ARM

Do not use any tools to attach the tow ball arm.

Note: *You can only attach the tow ball arm if it is unlocked, with the mark on the handwheel red. If the mark on the handwheel is amber, push the handwheel in and turn 180° clockwise to unlock.*

2. Fully insert the tow ball arm until it engages. Do not hold the handwheel.

Note: *The mark on the handwheel turns from red to green.*

3. Remove the protective cap.
4. Insert the key and turn it clockwise to lock the handwheel.
5. Fit the protective cap. Fully push it back over the lock.

Connecting a Trailer

6. Turn the trailer wiring connection socket downward through 90° until it engages in the end position.

Tow Ball Arm Safety Checks

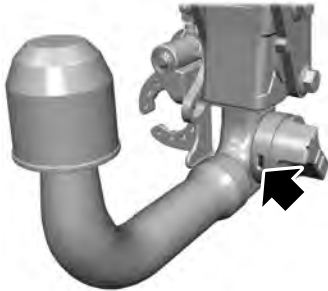

After you attach the tow ball arm, make sure:

- The mark on the handwheel is green.
- You have locked the handwheel.
- You have removed the key.

Do not use the tow ball arm if any of these cannot be met. Have your vehicle checked as soon as possible.

Towing a Trailer

TOWING A TRAILER PRECAUTIONS



WARNING: Do not exceed 100 km/h (60 mph). Failure to follow this instruction could result in the loss of control of your vehicle, personal injury or death.



WARNING: The rear tire pressures must be increased by 0.2 bar (3 psi) above specification. Do not exceed the maximum pressure stated on the tire sidewall. This could cause serious personal injury.



WARNING: Do not exceed the maximum gross vehicle weight stated on the vehicle identification plate. Failure to follow this instruction could result in personal injury.



WARNING: Towing trailers beyond the maximum recommended gross trailer weight exceeds the limit of your vehicle and could result in vehicle damage, loss of vehicle control, vehicle rollover and personal injury.



WARNING: Do not exceed the maximum vertical load on the tow ball. Failure to follow this instruction could result in the loss of control of your vehicle, personal injury or death.



WARNING: The anti-lock brake system does not control the trailer brakes.

Note: Not all vehicles are suitable or approved to have a tow bar fitted. Ask an authorized dealer for more information.

Note: The maximum permissible trailer vertical weight on the trailer identification plate is the trailer manufacturer's testing value. The vehicle maximum permissible trailer vertical weight may be lower.

TRAILER TOWING HINTS

Towing a trailer changes the handling characteristics of your vehicle and increases stopping distances. Adapt your speed and driving behavior to the load of the trailer.

The stability of your vehicle-to-trailer combination depends on the quality of the trailer.

When towing a trailer:

- Obey country specific regulations for towing a trailer.
- Do not exceed 100 km/h (60 mph) even if a country allows higher speeds under certain conditions.
- Place loads as low as possible and central to the axle of your trailer. If you are towing with an unloaded vehicle, you should place the load in your trailer toward the front, within the maximum vertical load, as this gives the best stability.
- The trailer vertical weight on the tow ball is essential for the driving stability of your vehicle and trailer.
- The vertical weight on the tow ball should be at least 4% of the trailer weight and not exceed the maximum permissible weight.
- Reduce speed immediately if the trailer shows any sign of swaying.

TOWING A TRAILER LIMITATIONS

The vehicle's trailer towing capacity could be limited by outside temperatures.

Towing a Trailer

Note: We recommend that you use a trailer safety cable. Read and follow the manufacturer's instructions when you use a trailer safety cable.

TOWING WEIGHTS AND DIMENSIONS

TOW BAR DIMENSIONS

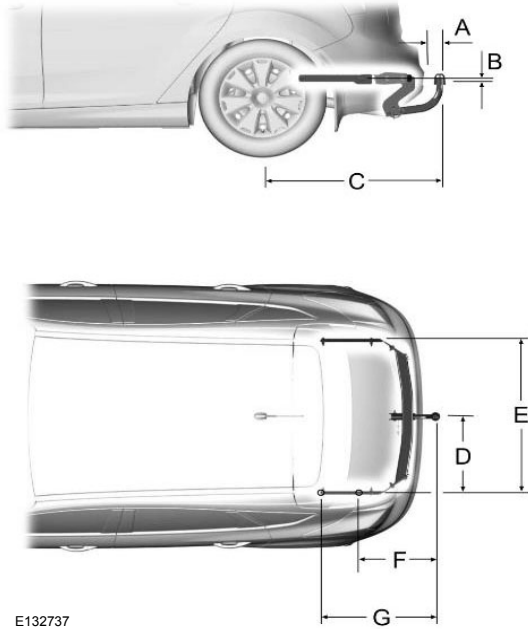

E132737

Towing a Trailer

Item	Dimension Description	Dimension mm (in)
A	Bumper to center of tow ball.	71 (3)
B	Attachment point to center of tow ball.	55 (2)
C	Wheel center to center of tow ball.	937 (37)
D	Center of tow ball to side member.	485 (19)
E	Distance between side members.	970 (38)
F	Center of tow ball to center of first attachment point.	420 (17)
G	Center of tow ball to center of second attachment point.	570 (22)

Maximum Permissible Trailer Vertical Weight

Battery	kg (lb)
Standard range battery vehicles and GT	30 (66)
Extended range battery vehicles	60 (132)

Trailer Sway Control

HOW DOES TRAILER SWAY CONTROL WORK

The system applies the brakes to the individual wheels and reduces engine torque to aid vehicle stability.

If the trailer begins to sway, the stability control lamp flashes and the message **Trailer sway Reduce speed** appears in the information display.

Stop your vehicle as soon as it is safe to do so. Check the vertical weight on the tow ball and trailer load distribution.

TRAILER SWAY CONTROL PRECAUTIONS



WARNING: Turning off trailer sway control increases the risk of loss of vehicle control, serious injury or death. Ford does not recommend disabling this feature except in situations where speed reduction may be detrimental (such as hill climbing), the driver has significant trailer towing experience, and can control trailer sway and maintain safe operation.

Note: *This feature only activates when significant trailer sway occurs.*

Note: *This feature does not prevent trailer sway, but reduces it once it begins.*

Note: *This feature cannot stop all trailers from swaying.*

Note: *In some cases, if vehicle speed is too high, the system may activate multiple times, gradually reducing vehicle speed.*

Driving Hints

COLD WEATHER PRECAUTIONS

The functional operation of some components and systems can be affected at temperatures below approximately -25°C (-13°F).

DRIVING ON SNOW AND ICE



WARNING: If you are driving in slippery conditions that require tire chains or cables, then it is critical that you drive cautiously. Keep speeds down, allow for longer stopping distances and avoid aggressive steering to reduce the chances of a loss of vehicle control which can lead to serious injury or death. If the rear end of your vehicle slides while cornering, steer in the direction of the slide until you regain control of your vehicle.

On ice and snow, you should drive more slowly than usual. Your vehicle has a four wheel anti-lock brake system, do not pump the brake pedal. See **Anti-Lock Braking System Limitations** (page 195).

BREAKING-IN

You need to break in new tires for approximately 480 km (300 mi). During this time, your vehicle may exhibit some unusual driving characteristics.

PERFORMANCE VEHICLE PRECAUTIONS

- Verify correct tire pressures.
- Inspect wheels and tires for wear and damage. Replace any damaged wheels or tires.

- Do not operate your vehicle at high speeds with more than two passengers or while carrying cargo.
- It is recommended to cross speed bumps or driveway inclines slowly and at a 45° angle to reduce the risk of vehicle damage.
- Do not drive through car washes with the vehicle heavily loaded with passengers or luggage.
- Use only commercial car washes without mechanical tracks or hand wash to avoid potential damage.
- Put your vehicle in stay in neutral mode when entering an automatic car wash. See **What Is Temporary Neutral Mode** (page 191).

DRIVING IN SPECIAL CONDITIONS

EMERGENCY MANEUVERS

In an unavoidable emergency where you must make a sudden sharp maneuver, turn the steering wheel only as rapidly and as far as required to avoid the emergency. Apply smooth pressure to the accelerator pedal or brake pedal as needed. Avoid abrupt steering, acceleration and braking changes. Abrupt changes could increase the risk of vehicle roll over, loss of vehicle control and personal injury. If possible, use any available road surfaces to bring your vehicle under control.

Driving Hints

DRIVING THROUGH MUD AND WATER

Mud

Be cautious of sudden changes in vehicle speed or direction when you are driving in mud. Even all-wheel drive and four-wheel drive vehicles can lose traction in mud. If your vehicle slides, steer in the direction of the slide until you regain control of your vehicle. After driving through mud, clean off residue stuck to rotating driveshafts and tires. Excess residue can cause an imbalance that could damage drive components.

Note: *If your vehicle gets stuck in mud, it could be rocked out by shifting between forward and reverse gears, stopping between shifts in a steady pattern. Press lightly on the accelerator in each gear.*

Water

If you must drive through water approach it cautiously. See **Driving Through Shallow Water** (page 309).

DRIVING ON HILLY OR SLOPING TERRAIN

Although natural obstacles could make it necessary to travel diagonally up or down a hill or steep incline, you should try to drive straight up or straight down.

Note: *Avoid turning on steep slopes or hills. A danger lies in losing traction, slipping sideways and possible vehicle roll over. Whenever driving on a hill, determine beforehand the route you can use. Do not drive over the crest of a hill without seeing what conditions are on the other side. Do not drive in reverse over a hill without the aid of an observer.*

Apply just enough power to the wheels to climb the hill. Too much power causes the tires to slip, spin or lose traction, and you could lose control of your vehicle. When descending a steep hill, do not descend the hill in neutral. Avoid sudden hard braking to keep the front wheels rolling and to maintain your vehicle's steering.

Note: *Your vehicle has anti-lock brakes, apply the brakes steadily. Do not pump the brakes.*

DRIVING IN SAND

When driving over sand, try to keep all four wheels on the most solid area of the trail. Shift to a lower gear and drive steadily through the terrain. Apply the accelerator slowly and avoid excessive wheel slip. Do not drive your vehicle in deep sand for an extended period of time. This could overheat the system. A message appears in the information display. See **All-Wheel**

Drive – Information Messages (page 194).

Note: *If your vehicle gets stuck in sand, it could be rocked out by shifting between forward and reverse gears, stopping between shifts in a steady pattern. Press lightly on the accelerator in each gear.*

ELECTRIC VEHICLE

MAXIMIZING YOUR DRIVING RANGE

Driving in Cold Weather

Keep your vehicle charged before heading out into cold weather.

Use the heated seats and steering wheel for comfort along with moderate cabin temperature and fan settings to reduce energy needed for climate control.

Driving Hints

Preconditioning Your Vehicle

You can precondition your vehicle by using departure and comfort settings to warm or cool your cabin and the high voltage battery when your vehicle is plugged in. By using energy from your charging source prior to your departure, battery temperature can be managed for best driving performance and less energy will be needed for heating or cooling of the cabin at the start of your drive. This helps maximize your driving range. See **Setting the Charging Schedule and Preferences** (page 180).

Note: You can also access departure and comfort settings using the FordPass App.

Note: Lower cabin temperature settings on the climate control system results in better trip range.

Parking Your Vehicle

At temperatures just above the freezing point and lower, plug your vehicle in when not in use to maintain high voltage battery performance.

When possible park your vehicle under a covered area or in a garage. This will help to moderate temperatures which affect performance of the high voltage battery and require energy to heat or cool the cabin.

Driving Style

Range is reduced when driving aggressively or at consistently high speeds. Aggressive driving for extended periods could also result in reducing your battery's efficiency and lifespan. Use the trip application on your touchscreen to see your driving scores. See **Trip Data** (page 129).

DRIVING IN COLD WEATHER

Pack a small supply kit with a 12 V jump box, blanket, snow scraper and gloves during winter.

We recommend winter tires with sufficient tread depth for traction.

Clear snow and ice from the roof, hood, all windows and mirrors. Remove piled up snow or ice from the wipers and washer nozzles. Allow time for windows to defrost and interior controls to warm up before driving.

Preconditioning Your Vehicle

You can precondition your vehicle to warm or cool the cabin and the high voltage battery when you have your vehicle plugged in. You can charge your vehicle to the targeted level and also make sure your vehicle is at a comfortable temperature for the occupants.

Note: You can precondition your vehicle prior to your departure using the FordPass app.

Keep your vehicle fully charged before heading out into cold weather.

Note: Using seat heaters is more efficient for warming occupants than using the heat from the climate control.

Note: Lower cabin temperature settings on the climate control system results in better trip range.

DRIVING THROUGH SHALLOW WATER



WARNING: Do not attempt to cross a deep or flowing body of water. Failure to follow this instruction could result in the loss of control of your vehicle, personal injury or death.

Driving Hints

Note: Driving through standing water can cause vehicle damage.

Note: Engine damage can occur if water enters the air filter.

Before driving through standing water, check the depth. Never drive through water that is higher than the bottom of the front rocker area of your vehicle.



When driving through standing water, drive very slowly and do not stop your vehicle. Your brake performance and traction could be limited. After driving through water and as soon as it is safe to do so:

- Lightly press the brake pedal to dry the brakes and to check that they work.
- Turn the steering wheel to check that the steering power assist works.

Check the function of the following:

- Horn
- Exterior lights

FLOOR MATS



WARNING: Use a floor mat designed to fit the footwell of your vehicle that does not obstruct the pedal area. Failure to follow this instruction could result in the loss of control of your vehicle, personal injury or death.



WARNING: Pedals that cannot move freely can cause loss of vehicle control and increase the risk of serious personal injury.



WARNING: Secure the floor mat to both retention devices so that it cannot slip out of position and interfere with the pedals. Failure to follow this instruction could result in the loss of control of your vehicle, personal injury or death.



WARNING: Do not place additional floor mats or any other covering on top of the original floor mats. This could result in the floor mat interfering with the operation of the pedals. Failure to follow this instruction could result in the loss of control of your vehicle, personal injury or death.



WARNING: Always make sure that objects cannot fall into the driver foot well while your vehicle is moving. Objects that are loose can become trapped under the pedals causing a loss of vehicle control.



To install the floor mats, position the floor mat eyelet over the retention post and press down to lock in position.

Driving Hints

To remove the floor mat, reverse the installation procedure.

Note: *Regularly check the floor mats to make sure they are secure.*

Crash and Breakdown Information

SWITCHING THE HAZARD FLASHERS ON AND OFF

The hazard flashers operate with the power on or off. The battery loses charge and may have insufficient power to restart your vehicle.



The hazard flasher button is on the center console. Press the button to turn on the hazard flashers if your vehicle is creating a safety hazard for other road users.

When you switch the hazard flashers on, all front and rear direction indicators flash. Press the button again to switch them off.

JUMP STARTING THE VEHICLE

JUMP STARTING PRECAUTIONS



WARNING: Connect batteries with only the same nominal voltage.



WARNING: Use only adequately sized cables with insulated clamps.

Note: This procedure is only for the 12 volt under hood battery.

Note: Your vehicle has a 12 volt battery that is easily accessible under the hood. The 12 volt battery controls the switches and contacts that engage the high voltage battery. Do not jump start the high voltage battery using a standard 12 volt battery. Tow your vehicle to an authorized dealer if the high voltage battery does not accept a regular charge.

Note: Do not attempt to push start your vehicle. You could cause transmission damage.

Note: Do not disconnect the 12 volt battery from your vehicle electrical system.

PREPARING THE VEHICLE

Opening the Front Luggage Compartment With No Vehicle Power

If the vehicle has no power, you will be unable to open the front luggage compartment. To open the front luggage compartment follow the steps below:

1. Use an external power supply such as a 12 volt jump box.

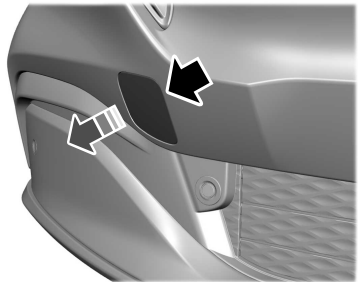

2. Remove the cover at the front of your vehicle below the headlight. Press firmly on the top right of the covers edge, then pull the raised section on the bottom left toward you.

Crash and Breakdown Information

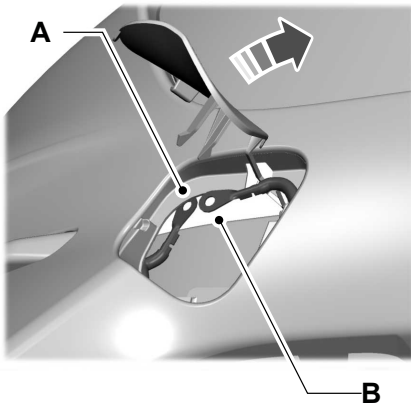

3. Pull both wires out of the opening to reveal both terminals.
4. Connect the external power supply to the terminals

Note: Be sure to match the red positive cable (A) to the red positive terminal and the black negative cable (B) to the black negative terminal.

5. Turn on the external power supply.

Note: Refer to the manufacturer's instructions for external power supply use.

Note: If performed correctly, the front luggage compartment latches immediately release, and you have access to the front luggage compartment.

6. Disconnect the external power supply when it is no longer required.
7. To reinstall the cover, reverse the removal procedure.

To Connect the Booster Cables

WARNING: Do not connect the negative jumper cable to any other part of your vehicle. Use the ground point.

To access the booster cable connection points, remove the rear and left side front luggage compartment covers. See **Installing and Removing the Luggage Compartment Cover** (page 297).

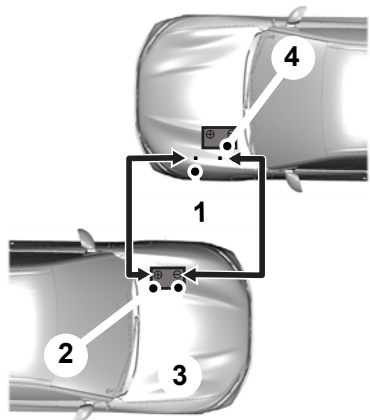

Note: Make sure that the cables are clear of any moving parts.

Crash and Breakdown Information

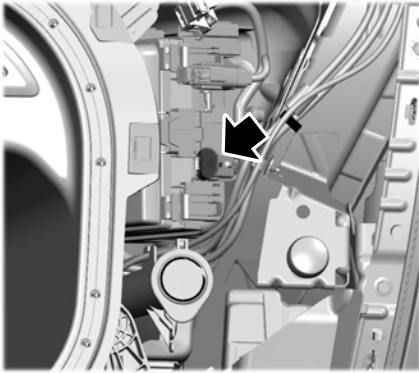

1. Connect the positive (+) jumper cable to the positive (+) jump point of the discharged battery vehicle.
2. Connect the other end of the positive (+) jumper cable to the positive (+) terminal of the booster vehicle battery.
3. Connect the negative (-) jumper cable to the negative (-) terminal of the booster vehicle battery.

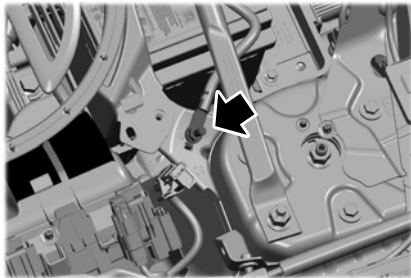

4. Make the final connection of the negative (-) jumper cable to the negative (-) ground point of the discharged battery vehicle.

5. Unlock the driver door. See **Unlocking and Locking the Doors Using the Remote Control** (page 74).

JUMP STARTING THE VEHICLE

To Start Your Vehicle

1. Run the engine of the booster vehicle at a moderately high speed.
2. Move the transmission selector lever of the low charge vehicle to park (P).
3. Switch on the ready to drive mode. See **Starting the Vehicle** (page 156).
4. Run both vehicles for a minimum of three minutes before disconnecting the cables.

Note: Do not switch the headlamps on when disconnecting the cables. The peak voltage could damage the bulbs.

Disconnect the cables in the reverse order.

POST-CRASH ALERT SYSTEM

WHAT IS THE POST-CRASH ALERT SYSTEM

The system helps draw attention to your vehicle in the event of a serious impact.

HOW DOES THE POST-CRASH ALERT SYSTEM WORK

The system is designed to turn the hazard flashers on, turn the courtesy lamps on, intermittently sound the horn and unlock all doors in the event of a serious impact that deploys an airbag or the seatbelt pretensioners.

Crash and Breakdown Information

POST-CRASH ALERT SYSTEM LIMITATIONS

Depending on applicable laws in the country your vehicle was built for, the horn does not sound in the event of a serious impact.

SWITCHING THE POST-CRASH ALERT SYSTEM OFF

Press the hazard flasher switch, the unlock button on the remote control, the panic button on the remote control or cycle the ignition to switch the system off.

Note: *The alert turns off when the vehicle battery runs out of charge.*

POST-COLLISION BRAKING

How Does Post-Collision Braking Work

In the event of a moderate to severe crash, the braking system reduces the vehicle's speed to prevent or reduce the impact of a potential secondary crash.

Post-Collision Braking Limitations

Post-collision braking does not activate if any of the following occur:

- The anti-lock braking system is damaged during the collision.
- Electronic stability control is disabled.

Overriding Post-Collision Braking

You can override post-collision braking by pressing the brake or accelerator pedal.

Post-Collision Braking Indicators



It flashes when a post-collision braking event is occurring.

AUTOMATIC CRASH SHUTOFF

WHAT IS AUTOMATIC CRASH SHUTOFF

The system deactivates the high voltage system if it is a battery or hybrid-electric vehicle, in the event of a moderate or severe crash.

RE-ENABLING YOUR VEHICLE

1. Switch your vehicle off.
2. Attempt to start your vehicle.
3. Switch your vehicle off.
4. Attempt to start your vehicle.

Note: *If your vehicle does not start after the third attempt, have your vehicle checked as soon as possible.*

RECOVERY TOWING

ACCESSING THE FRONT TOWING POINT

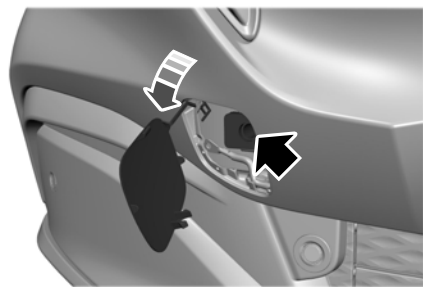

The front towing point is on the right-hand side of the front bumper. To remove the cover:

1. Gently press the top of the cover inward.

Crash and Breakdown Information

2. Gently lift the cover upward and then pull it straight out.

Note: The cover has a small lanyard to keep it attached to the bumper.

ACCESSING THE REAR TOWING POINT

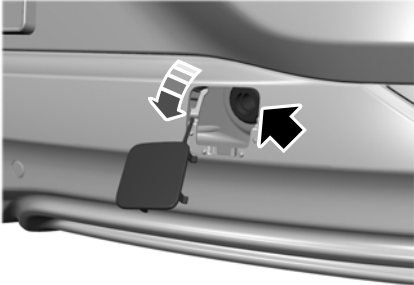

The rear towing point is on the right-hand side of the rear bumper. To remove the cover:

1. Gently press the top of the cover inward.
2. Gently lift the cover upward and then pull it straight out.

Note: The cover has a small lanyard to keep it attached to the bumper.

LOCATING THE TOWING EYE

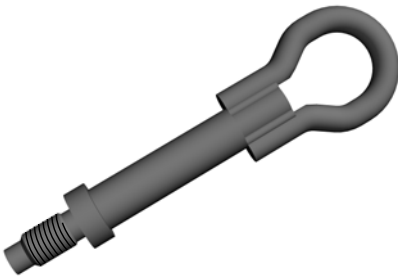

The towing eye is in the spare wheel storage tray.

INSTALLING THE TOWING EYE



WARNING: Make sure that the towing eye is fully tightened. Failure to follow this instruction could result in personal injury.

The towing eye has a left-hand thread. Insert the towing eye into the towing point and turn it counterclockwise to install it. Make sure that you fully tighten the recovery hook.

TRANSPORTING THE VEHICLE

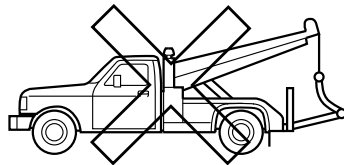
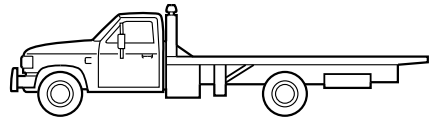
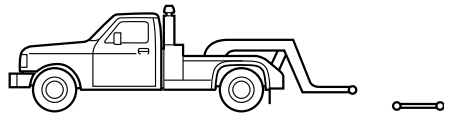

Crash and Breakdown Information

If you need to have your vehicle towed, contact a professional towing service or your roadside assistance service provider.

We recommend the use of a wheel lift and dollies or flatbed equipment to tow your vehicle. Do not tow with a slingbelt. We do not approve a slingbelt towing procedure. Vehicle damage may occur if towed incorrectly, or by any other means.

Your manufacturer produces a towing manual for all authorized tow truck operators. Have your tow truck operator refer to this manual for proper hook-up and towing procedures.

Towing your vehicle requires that all wheels be off the ground. This prevents damage to the mechanical systems and vehicle.

When using wheel lift equipment to tow the vehicle from the front, place the rear wheels on a tow dolly.

When using wheel lift equipment to tow the vehicle from the rear, place the front wheels on a tow dolly.

Towing Your Vehicle

TOWING YOUR VEHICLE PRECAUTIONS

Use the following guidelines when towing your vehicle. Failure to follow this instruction could result in vehicle damage not covered by the vehicle warranty.

Note: Make sure you properly secure your vehicle to the tow vehicle.

Note: If you are unsure of the vehicle's configuration, contact an authorized dealer.

EMERGENCY TOWING

If your vehicle becomes inoperable without access to wheel dollies or a vehicle transport trailer, it can be flat-towed with all wheels on the ground, regardless of the drivetrain, under the following conditions:

- Your vehicle is facing forward for towing in a forward direction.
- You switch Emergency Tow on.
- Maximum speed is 50 km/h (30 mph).
- Maximum distance is 80 km (50 mi).

Switching Emergency Tow On

1. Properly secure your vehicle to the tow vehicle.

2. Switch your vehicle on to accessory mode. See **Starting and Powering Off** (page 156).

3. Apply the parking brake.

- 4.



Press the button on the touchscreen.

5. Press **Vehicle**.

6. Press and hold Emergency Tow until a confirmation message appears on the touchscreen.

7. Press and hold the brake pedal.

8. Shift into neutral (N).

Note: A confirmation message appears in the instrument cluster display.

9. Release the parking brake.

10. Switch your vehicle off.

Switching Emergency Tow Off

1. Switch your vehicle on.

2. Press and hold the brake pedal.

3. Shift into park (P). A message displays in the instrument cluster display and park (P) displays in the instrument cluster display and on the shifter.

Towing Your Vehicle

TOWING YOUR VEHICLE – TROUBLESHOOTING

TOWING YOUR VEHICLE – INFORMATION MESSAGES

Message	Description
Neutral tow Remove park brake for towing	Displays to remind you to release the parking brake to emergency tow your vehicle.
Neutral tow disengaged	Displays when emergency tow is off.
Neutral tow engaged Turn ignition off for towing	Displays to remind you to switch off the vehicle to emergency tow your vehicle.
Neutral tow engaged Depress brake and select Park to exit Neutral tow	Displays to remind you that emergency towing is active. To exit emergency towing, shift to park (P).

Note: *You cannot recreationally tow your vehicle. You can only emergency tow your vehicle.*

Fuses

FUSE PRECAUTIONS

 **WARNING:** Always disconnect the battery before servicing high current fuses.

 **WARNING:** To reduce risk of electrical shock, always replace the cover to the power distribution box before reconnecting the battery or refilling fluid reservoirs.

 **WARNING:** Always replace a fuse with one that has the specified amperage rating. Using a fuse with a higher amperage rating can cause severe wire damage and could start a fire.

UNDER HOOD FUSE BOX

LOCATING THE UNDER HOOD FUSE BOX

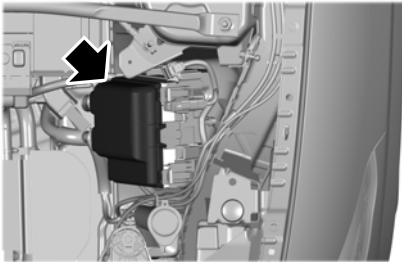

ACCESSING THE UNDER HOOD FUSE BOX

1. Remove the luggage compartment cover. See **Installing and Removing the Luggage Compartment Cover** (page 297).

- 
2. Pull the latch toward you and remove the top cover.

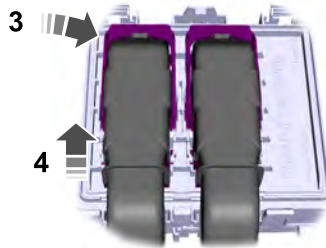

3. Pull the connector lever upward.
4. Pull the connector upward to remove it.

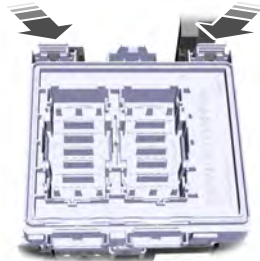

5. Pull both latches toward you and remove the fuse box.

Fuses

6. Turn the fuse box over and open the lid.

IDENTIFYING THE FUSES IN THE UNDER HOOD FUSE BOX

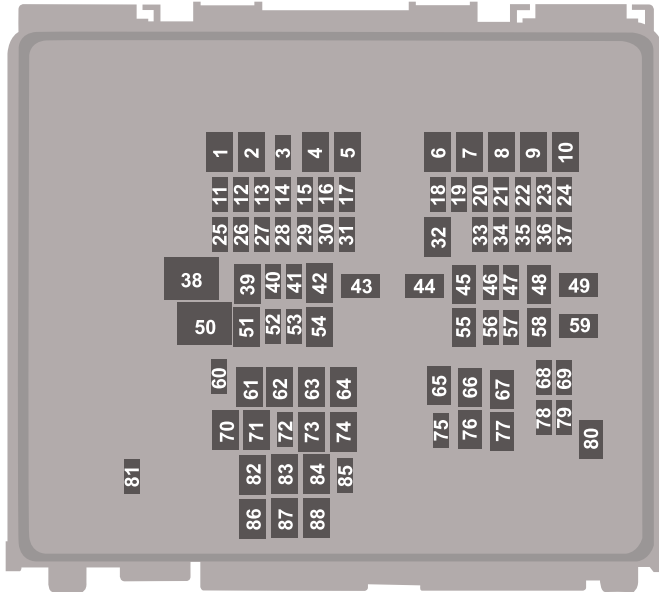

Item	Rating	Protected Component
1	—	Not used.
2	40 A	Left-hand windshield defroster.
3	—	Not used.
4	40 A	Right-hand windshield defroster. Windshield heated washer jets.
5	—	Not used.
6	—	Not used.

Fuses

Item	Rating	Protected Component
7	—	Not used.
8	—	Not used.
9	—	Not used.
10	—	Not used.
11	15 A	Powertrain control module.
12	—	Not used.
13	15 A	A/C electric compressor. Active grille shutter. Powertrain control module heater cooling pump. Powertrain control module heater shut off valve.
14	15 A	Secondary drive unit transmission oil pump (GT).
15	—	Not used.
16	10 A	Battery charge control module.
17	20 A	Steering column lock.
18	10 A	Powertrain control module.
19	10 A	Brake system control module.
20	5 A	Charge port status indicator.
21	5 A	Frunk actuator relay coil.
22	20 A	Amplifier.
23	20 A	Rear driver side electronic door.
24	—	Not used.
25	25 A	Left-hand enhanced head-lamps.
26	25 A	Right-hand enhanced head-lamps.

Fuses

Item	Rating	Protected Component
27	5 A	Keep alive power.
28	5 A	Frunk actuator relay coil.
29	5 A	DC/DC converter.
30	—	Not used.
31	5 A	Electronic power assist steering.
32	30 A	Body control module.
33	20 A	Advanced driver assistance system.
34	10 A	Headlamp control module. Left-hand headlamp. Right-hand headlamp.
35	15 A	Heated steering wheel.
36	10 A	Primary hybrid powertrain control module. Auxiliary power distribution box. Secondary hybrid powertrain control module.
37	20 A	Horn.
38	40 A	Blower motor.
39	—	Not used.
40	—	Not used.
41	20 A	Amplifier.
42	30 A	Driver power seat.
43	40 A	Anti-lock brake system valves.
44	60 A	Auxiliary power distribution box.
45	30 A	Passenger power seat.
46	—	Not used.

Fuses

Item	Rating	Protected Component
47	—	Not used.
48	—	Not used.
49	60 A	Anti-lock brake system pump.
50	60 A	Cooling fan.
51	—	Not used.
52	5 A	USB port.
53	—	Not used.
54	—	Not used.
55	30 A	Heated seats.
56	20 A	Frunk module.
57	10 A	Data link connector.
58	—	Not used.
59	40 A	Body control module.
60	—	Not used.
61	20 A	Auxiliary power point.
62	—	Not used.
63	—	Not used.
64	30 A	Power liftgate.
65	30 A	Vehicle dynamics module.
66	—	Not used.
67	—	Not used.
68	5 A	Battery electronic control module.
69	20 A	Rear passenger side electronic door.
70	—	Not used.
71	20 A	Auxiliary power point.

Fuses

Item	Rating	Protected Component
72	20 A	Rear window wiper.
73	—	Not used.
74	30 A	Windshield wiper motor.
75	—	Not used.
76	30 A	Heated rear window.
77	—	Not used.
78	20 A	Front driver side electronic door.
79	20 A	Front passenger side electronic door.
80	—	Not used.
81	10 A	Rear window washer pump.
82	—	Not used.
83	—	Not used.
84	40 A	Trailer tow lighting module.
85	5 A	Rain sensor.
86	—	Not used.
87	—	Not used.
88	—	Not used.

Fuses

BATTERY FUSE BOX

LOCATING THE BATTERY FUSE BOX

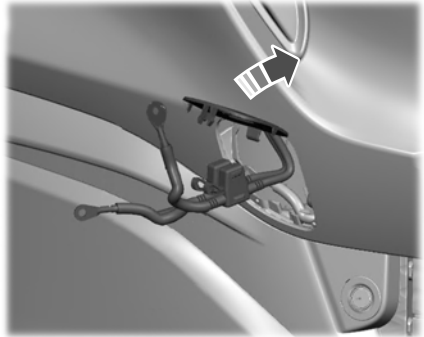
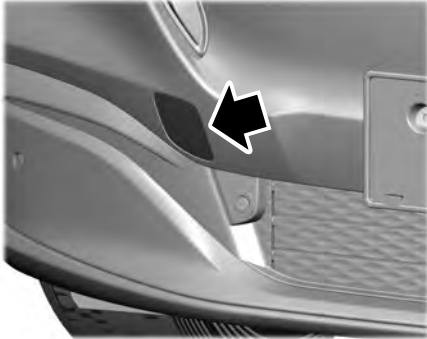

2. Pull both wires out of the opening to reveal the inline fuses.

ACCESSING THE BATTERY FUSE BOX

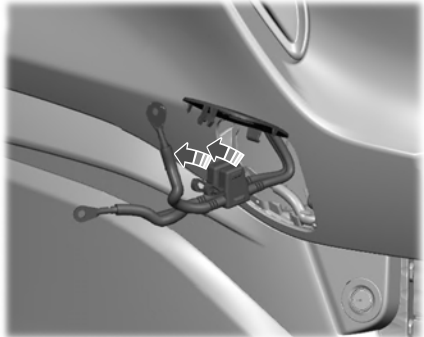
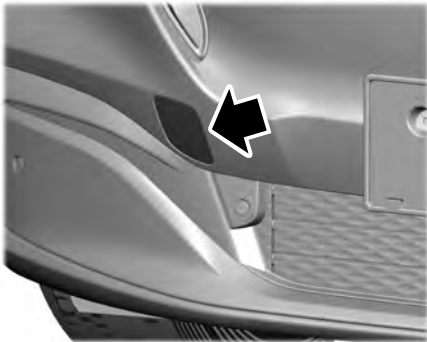

3. Remove the caps that cover the inline fuses.

1. Press the top right-hand side of the cover, then pull the raised section on the bottom left-hand side toward you.

Fuses

IDENTIFYING THE FUSES IN THE BATTERY FUSE BOX

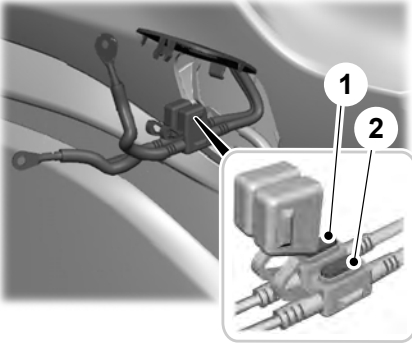

Item	Rating	Protected Component
1	20 A	Frunk.
2	20 A	Frunk.

BODY CONTROL MODULE FUSE BOX

LOCATING THE BODY CONTROL MODULE FUSE BOX



ACCESSING THE BODY CONTROL MODULE FUSE BOX



Fuses

IDENTIFYING THE FUSES IN THE BODY CONTROL MODULE FUSE BOX

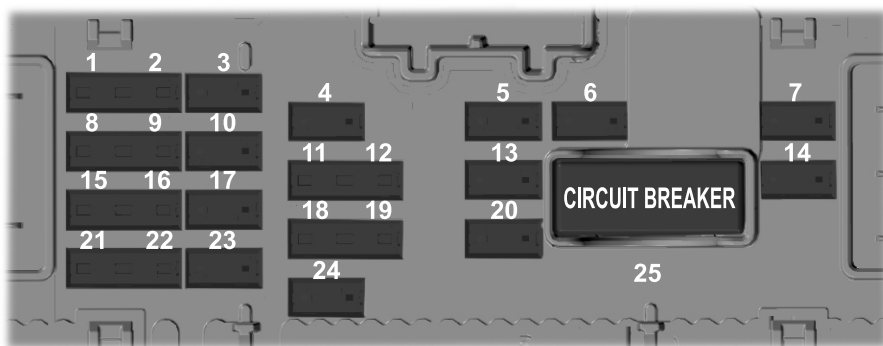

Fuse Location	Fuse Rating	Protected Component
1	5 A	Restraints control module.
2	5 A	Not used.
3	10 A	Not used.
4	10 A	Multi-function display.
5	20 A	Not used.
6	10 A	Not used.
7	30 A	Passenger door module.
8	5 A	Not used.
9	5 A	Auto-dimming exterior mirror. Passenger airbag deactivation indicator.
10	10 A	Not used.
11	5 A	Power liftgate. Hands-free liftgate actuation module.
12	5 A	Anti-theft alarm. Keyless keypad switch. Front driver door activation switch. Rear driver door activation switch.

Fuses

Fuse Location	Fuse Rating	Protected Component
13	15 A	Not used.
14	30 A	Driver door module.
15	15 A	Not used.
16	15 A	Active suspension (GT).
17	15 A	SYNC.
18	7.5 A	Wireless accessory charging module. Driver status monitor. Front passenger door activation switch. Rear passenger door activation switch.
19	7.5 A	Headlamp switch pack. Bluetooth low energy module. Telematics control unit module. Push button start.
20	10 A	Anti-theft alarm horn.
21	7.5 A	Gateway module. Climate control. Gear shift module.
22	7.5 A	Instrument cluster. Steering column control module.
23	20 A	Audio unit.
24	20 A	Battery backup sounder.
25	30 A Circuit Breaker	Not used.

Fuses

IDENTIFYING FUSE TYPES

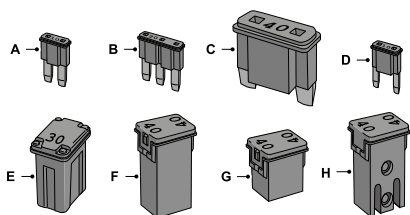

- A Micro 2.
- B Micro 3.
- C Maxi.
- D Mini.
- E M Case.
- F J Case.
- G J Case Low Profile.
- H Slotted M Case.

FUSES – TROUBLESHOOTING

FUSES – FREQUENTLY ASKED QUESTIONS

When do I need to check a fuse?

- If electrical components in the vehicle are not working.

When do I need to replace a fuse?

- If a fuse has blown.

How do I identify a blown fuse?

- You can identify a blown fuse by a broken wire within the fuse.

Maintenance

MAINTENANCE PRECAUTIONS

Have your vehicle serviced regularly to help maintain its roadworthiness and resale value. There is a large network of authorized dealers that are there to help you with their professional servicing expertise. We believe that their specially trained technicians are best qualified to service your vehicle properly and expertly. They are supported by a wide range of highly specialized tools developed specifically for servicing your vehicle.

If your vehicle requires professional service, an authorized dealer can provide the necessary parts and service. Check your warranty information to find out which parts and services are covered.

Use only recommended fluids and service parts conforming to specifications. See **Capacities and Specifications** (page 359).

OPENING AND CLOSING THE HOOD

See **Opening the Frunk from Inside Your Vehicle** (page 295).

UNDER HOOD OVERVIEW

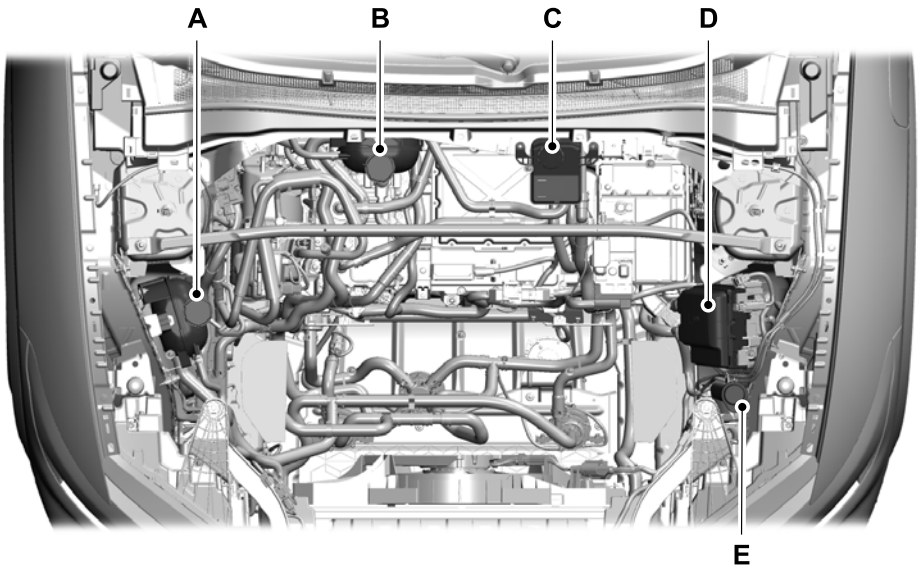

Maintenance

- A Motor electronic coolant reservoir. See **Checking the Coolant** (page 332).
- B Battery coolant reservoir. See **Checking the Coolant** (page 332).
- C Brake fluid reservoir. See **Checking the Brake Fluid** (page 195).
- D Under hood fuse box. See **Under Hood Fuse Box** (page 320).
- E Windshield washer fluid reservoir. See **Adding Washer Fluid** (page 103).

Note: *Some of these components are underneath the luggage compartment cover and cannot be seen unless the cover is removed. See **Installing and Removing the Luggage Compartment Cover** (page 297).*

CHECKING THE COOLANT



WARNING: Do not remove the coolant reservoir cap when the vehicle is on or the cooling system is hot. Wait 10 minutes for the cooling system to cool down. Cover the coolant reservoir cap with a thick cloth to prevent the possibility of scalding and slowly remove the cap. Failure to follow this instruction could result in personal injury.



WARNING: Do not put coolant in the windshield washer reservoir. If sprayed on the windshield, coolant could make it difficult to see through the windshield.



WARNING: Do not add coolant further than the **MAX** mark.

Note: *Coolant expands when it is hot. The level may extend beyond the **MAX** mark.*

Your vehicle has a battery cooling system and a motor electrical cooling system. See **Under Hood Overview** (page 331). The luggage compartment covers need to be removed in order to access the reservoirs. See **Installing and Removing the Luggage Compartment Cover** (page 297).

When the electric motor is cold, check the concentration and level of the coolant at the intervals listed in the scheduled maintenance information.

Maintain coolant concentration within 48% to 50%, which equates to a freeze point between -34--37°C (-29--35°F). Check coolant concentration using a refractometer. We do not recommend the use of hydrometers or coolant test strips for measuring coolant concentration.

Adding Coolant

It is very important to use prediluted coolant approved to the correct specification in order to avoid plugging the small passageways in the electric motor cooling system. See **Cooling System Capacity and Specification** (page 360).

Do not mix different colors or types of coolant in your vehicle. Mixing of coolants or using an incorrect coolant may harm the electric motor or cooling system components and may cause damage that the vehicle warranty may not cover.

Note: *Automotive fluids are not interchangeable.*

Note: *Do not use stop leak pellets, cooling system sealants, or non-specified additives as they can cause damage to the electric motor cooling or heating systems.*

Maintenance

Note: *If prediluted coolant is not available, use the approved concentrated coolant diluting it to 50/50 with distilled water. See*

Cooling System Capacity and Specification (page 360). *Using water that has not been deionized could contribute to deposit formation, corrosion and plugging of the small cooling system passageways.*

Note: *Coolants marketed for all makes and models might not meet our specifications and could cause damage to the cooling system. Resulting component damage could void the vehicle warranty.*

If the coolant level is at or below the minimum mark, add prediluted coolant immediately.

To top up the coolant level do the following:

1. Unscrew the cap slowly. Any pressure escapes as you unscrew the cap.
2. Add prediluted coolant approved to the correct specification. See **Cooling System Capacity and Specification** (page 360).
3. Add enough prediluted coolant to reach the correct level.
4. Replace the coolant reservoir cap. Turn the cap clockwise until it contacts the hard stop.
5. Check the coolant level in the coolant reservoir the next few times you drive your vehicle. If necessary, add enough prediluted coolant to bring the coolant level to the correct level.

If you have to add more than 1 L (1.1 qt) of coolant per month, have your vehicle checked as soon as possible. Operating your vehicle with a low level of coolant can result in overheating and possible electric motor damage.

In case of emergency, you can add a large amount of water without coolant in order to reach a vehicle service location. In this instance, have qualified personnel do the following as soon as possible:

1. Drain the cooling system.
2. Chemically clean the coolant system.
3. Refill with coolant.

Water alone, without coolant, can cause damage from corrosion, overheating or freezing.

Do not use the following as a coolant substitute:

- Alcohol.
- Methanol.
- Brine.
- Any coolant mixed with alcohol or methanol antifreeze.

Alcohol and other liquids can cause damage from overheating or freezing.

Do not add extra inhibitors or additives to the coolant. These can be harmful and compromise the corrosion protection of the coolant.

Recycled Coolant

We do not recommend the use of recycled coolant, as an approved recycling process is not yet available.

Dispose of used coolant in an appropriate manner. Follow your community's regulations and standards for recycling and disposing of automotive fluids.

Maintenance

Severe Climates

If you drive in extremely cold climates:

- It may be necessary to increase the coolant concentration above 50%.
- A coolant concentration of 60% provides improved freeze point protection.
- Coolant concentrations above 60% decrease the overheat protection characteristics of the coolant and may cause damage to the electric motor.

If you drive in extremely hot climates:

- You can decrease the coolant concentration to 40%.
- A coolant concentration of 40% provides improved overheat protection.
- Coolant concentrations below 40% decrease the overheat and corrosion protection characteristics of the coolant and may cause damage to the electric motor.

Coolant Change

Change the coolant at specific mileage intervals listed in the scheduled maintenance information. Add prediluted coolant approved to the correct specification. See **Cooling System Capacity and Specification** (page 360).

12V BATTERY

CHANGING THE 12V BATTERY

If the 12 volt battery needs servicing, see your authorized dealer.

CHARGING THE 12V BATTERY

Your vehicle has a high voltage to low voltage energy transfer feature that keeps the 12 volt battery charged by the high voltage battery. If the 12 volt battery level is low, the high voltage battery transfers energy to the 12 volt battery when the vehicle is off.

12V BATTERY – TROUBLESHOOTING

12V BATTERY – WARNING LAMPS



If it illuminates when the green ready to drive indicator is activated, this indicates your vehicle requires service. Have your vehicle checked as soon as possible.

Maintenance

12V BATTERY – INFORMATION MESSAGES

Message	Action
12V battery malfunction Service soon	Your vehicle has a 12 volt battery problem. We recommend having the battery system checked by an authorized EV dealer.
Electric range reduced due to park/hazard lamps on while vehicle off	The electric vehicle range is reduced due to the park and/or hazard lamps on while your vehicle was off.
Electrical system drain Service required	Your vehicle has an electrical drain within the vehicle. Please check for any after-market devices that could be draining the battery. If none are found, please have your vehicle serviced by an authorized EV dealer.

ADJUSTING THE HEADLAMPS

Vertical and Horizontal Aim Adjustment

Vertical and horizontal aim is adjustable. We recommend that you see an authorized dealer.

EXTERIOR BULBS

EXTERIOR BULB SPECIFICATION CHART

Your vehicle has LED lamps. These are not serviceable items. See an authorized dealer if they fail.

INTERIOR BULBS

INTERIOR BULB SPECIFICATION CHART

Your vehicle has LED lamps. These are not serviceable items. See an authorized dealer if they fail.

Vehicle Care

GENERAL INFORMATION

Your dealer has many quality products available to clean your vehicle and protect its finishes.

CLEANING THE EXTERIOR

CLEANING THE EXTERIOR PRECAUTIONS

Immediately remove additive residuals, bird droppings, insect deposits and road tar. These may damage your vehicle's paintwork or trim over time.

Remove any exterior accessories, for example antennas, before entering a car wash.

CLEANING HEADLAMPS AND REAR LAMPS

We recommend that you only use cold or lukewarm water containing car shampoo to clean the headlamps and the rear lamps.

Do not scrape the lamps.

Do not wipe lamps when they are dry.

CLEANING WINDOWS AND WIPER BLADES

To clean the windshield and wiper blades:

- Clean the windshield with a non-abrasive glass cleaner.

Note: *When cleaning the interior of the windshield, avoid getting any glass cleaner on the instrument panel or door panels. Wipe any glass cleaner off these surfaces immediately.*

- Clean the wiper blades with washer fluid or water applied with a soft sponge or cloth.

Note: *Do not use razor blades or other sharp objects to clean or remove decals from the inside of the heated rear window. This can cause damage not covered by the vehicle Warranty.*

CLEANING CHROME, ALUMINIUM OR STAINLESS STEEL

We recommend that you only use a car shampoo, a soft cloth and water on bumpers and other chrome, aluminium or stainless steel parts.

Note: *For additional information and assistance, we recommend that you contact an authorized dealer.*

Note: *Rinse the area well after cleaning.*

Note: *Do not use abrasive materials, for example steel wool or plastic pads, as they can scratch these surfaces.*

Note: *Do not use chrome cleaner, metal cleaner or polish on wheels or wheel covers.*

CLEANING WHEELS

Only use a recommended wheel and tire cleaner to clean the wheels weekly. For additional information and assistance, we recommend that you contact an authorized dealer.

1. Use a sponge to remove heavy deposits of dirt and brake dust.
2. Rinse well after cleaning.

Note: *Do not apply a cleaning chemical to warm or hot wheel rims and covers.*

If you intend on parking your vehicle for an extended period after cleaning the wheels with a wheel cleaner, drive your vehicle for a few minutes before parking your vehicle. This reduces the risk of corrosion of the brake discs, brake pads and linings.

Do not clean the wheels when they are hot.

Vehicle Care

Note: Some car washes could damage wheel rims and covers.

Note: Using non-recommended cleaners, harsh cleaning products, chrome wheel cleaners or abrasive materials could damage wheel rims and covers.

CLEANING STRIPES OR GRAPHICS

It is recommended to wash your vehicle by hand however, pressure washing may be used under the following conditions:

- Use a spray with a 40° wide spray angle pattern.
- Keep the nozzle at a 305 mm (12 in) distance and 90° angle to your vehicle's surface.
- Do not use water pressure higher than 10,000 kPa (1,450 psi).
- Do not use water hotter than 75°C (167°F).

Note: Holding the pressure washer nozzle at an angle to the vehicle's surface may damage graphics and cause the edges to peel away from the vehicle's surface.

CLEANING CAMERA LENSES AND SENSORS

We recommend that you only use lukewarm or cold water and a soft cloth to clean the camera lens and sensors.

Note: Do not pressure wash camera lens and sensors.

CLEANING THE UNDERBODY

Flush the complete underside of your vehicle frequently. Keep body and door drain holes free from packed dirt.

Rear suspension components may require regular cleaning with a power washer or a thorough rinse with a strong stream of water if the vehicle is operated in dusty or muddy environments. Rear leaf springs or other suspension components may emit squeaking or popping noises while operating the vehicle if particles, such as dirt, rocks, or other debris, are present in the components.

CLEANING THE INTERIOR

CLEANING THE INSTRUMENT PANEL

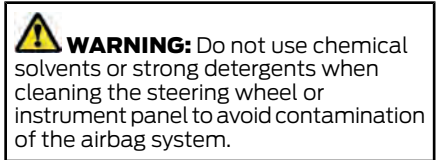

We recommend that you only clean the instrument panel and cluster lens with a damp soft cloth. Dry the area with a clean, soft cloth.

For additional information and assistance, we recommend that you contact an authorized dealer.

Note: Avoid cleaners or polishes that increase the gloss of the upper portion of the instrument panel. The dull finish in this area helps protect you from undesirable windshield reflection.

CLEANING PLASTIC

We recommend that you only use a mild soap and water solution on a soft cloth. Dry the area with a clean, soft cloth.

Vehicle Care

CLEANING DISPLAYS AND SCREENS

We recommend that you only use a microfiber cloth in a circular motion to clean off the fingerprint or dust.

If dirt or fingerprints are still on the screen, apply a small amount of alcohol to the cloth and try to clean it again.

Note: Do not pour or spray alcohol onto the touchscreen.

Note: Do not use detergent or any type of solvent to clean the touchscreen.

CLEANING FABRIC



WARNING: On vehicles equipped with seat-mounted airbags, do not use chemical solvents or strong detergents. Such products could contaminate the side airbag system and affect performance of the side airbag in a crash.

We recommend that you only clean fabric in the following way:

1. Remove dust and loose dirt with a vacuum cleaner.
2. Wipe the surface with a soft, damp cloth and a mild soap and water solution. Dry the area with a clean, soft cloth.
3. For additional information and assistance, we recommend that you contact an authorized dealer.

For heavy stains, spot clean the area. If a ring forms on the fabric, clean the entire area immediately, but do not oversaturate or the ring could set.

CLEANING VINYL



WARNING: On vehicles equipped with seat-mounted airbags, do not use chemical solvents or strong detergents. Such products could contaminate the side airbag system and affect performance of the side airbag in a crash.

We recommend that you only clean vinyl surfaces in the following way:

1. Remove dust and loose dirt with a vacuum cleaner.
2. Wipe the surface with a soft, damp cloth and a mild soap and water solution. Dry the area with a clean, soft cloth.
3. For additional information and assistance, we recommend that you contact an authorized dealer.

CLEANING CARPETS AND FLOOR MATS

We recommend that you only clean your carpets in the following way:

1. Remove dust and loose dirt with a vacuum cleaner.
2. Wipe the surface with a soft, damp cloth and a mild soap and water solution. Dry the area with a clean, soft cloth.
3. For additional information and assistance, we recommend that you contact an authorized dealer.

For heavy stains, spot clean the area. If a ring forms on the fabric, clean the entire area immediately, but do not oversaturate or the ring could set.

We recommend that you only clean your floor mats in the following way:

Vehicle Care

1. Remove dust and loose dirt with a vacuum cleaner.
2. Wash rubber floor mats using mild soap and lukewarm or cold water.
3. Completely dry the floor mat before placing them back in your vehicle.

Note: *Avoid waxing unpainted or low-gloss black colored parts, they discolor over time.*

CLEANING SEATBELTS



WARNING: Do not use cleaning solvents, bleach or dye on the vehicle's seatbelts, as these actions may weaken the belt webbing.

1. Wipe the surface with a soft, damp cloth and a mild soap and water solution. Dry the area with a clean, soft cloth.

CLEANING STORAGE COMPARTMENTS

1. Remove dust and loose dirt with a vacuum cleaner.
2. Wipe the surface with a soft, damp cloth and a mild soap and water solution. Dry the area with a clean, soft cloth.

WAXING YOUR VEHICLE

Wax the high-gloss painted surface of your prewashed vehicle once or twice a year.

We recommend that you only use an approved quality wax that does not contain abrasives. Follow the manufacturer's instructions to apply and remove the wax. For additional information and assistance, we recommend that you contact an authorized dealer.

When washing and waxing, park your vehicle in a shaded area out of direct sunlight.

Body Styling Kits

BODY STYLING KIT PRECAUTIONS

The distance between the underside of your vehicle and the ground is less than that of other models. Drive with extreme care to avoid damage to your vehicle.

Storing Your Vehicle

PREPARING YOUR VEHICLE FOR STORAGE

If you plan on storing your vehicle for 30 days or more, read the following maintenance recommendations to make sure your vehicle stays in good operating condition.

We engineer and test all vehicles and their components for reliable, regular driving. Under various conditions, long-term storage may lead to degraded performance or failure unless you use specific precautions to preserve vehicle components.

General

- Store all vehicles in a dry, ventilated place.
- Protect from sunlight, if possible.
- If vehicles are stored outside, they require regular maintenance to protect against rust and damage.

Body

- Wash your vehicle thoroughly to remove dirt, grease, oil, tar or mud from exterior surfaces, rear-wheel housing and the underside of front fenders.
- Periodically wash your vehicle if it is stored in exposed locations.
- Touch-up exposed or primed metal to prevent rust.
- Cover chrome and stainless steel parts with a thick coat of auto wax to prevent discoloration. Re-wax as necessary when you wash your vehicle.
- Lubricate all hood, door and luggage compartment hinges and latches with a light grade oil.
- Cover interior trim to prevent fading.
- Keep all rubber parts free from oil and solvents.

Cooling system

- Protect against freezing temperatures.
- When removing your vehicle from storage, check coolant fluid level. Confirm that there are no cooling system leaks and that fluid is at the recommended level.

Battery Systems

We recommend the following actions for your vehicle:

- When storing your vehicle for greater than 30 days the state of charge should be approximately 50%. Additionally, we recommend disconnecting the 12v battery which will reduce system loads on the HV battery.

Note: *Make sure the vehicle has been switched off and doors closed for at least five minutes before disconnecting the 12 volt battery.*

Brakes

- Make sure the brakes and parking brake release fully.

Tires

- Maintain recommended air pressure.

Miscellaneous

- Make sure all linkages, cables, levers and pins under your vehicle are covered with grease to prevent rust.
- Move vehicles at least 7.5 m (25 ft) every 15 days to lubricate working parts and prevent corrosion.

Storing Your Vehicle

REMOVING YOUR VEHICLE FROM STORAGE

When your vehicle is ready to come out of storage, do the following:

- Wash your vehicle to remove any dirt or grease film build-up on window surfaces.
- Check windshield wipers for any deterioration.
- Check tire pressures and set tire inflation per the Tire Label.
- Check brake pedal operation. Drive your vehicle 4.5 m (15 ft) back and forth to remove rust build-up.
- Check coolant levels to make sure there are no leaks, and fluids are at recommended levels.
- If you removed the 12 volt battery, clean the 12 volt battery cable ends and check for damage.

Contact an authorized dealer if you have any concerns or issues.

Wheel and Tire Information

LOCATING THE TIRE LABEL

The tire label or safety certification label is on the driver side B-pillar or the edge of the driver door. It contains information on the recommended front and rear tire inflation pressures.

USING SUMMER TIRES

Summer tires provide superior performance on wet and dry roads. Summer tires do not have the Mud and Snow (M+S or M/S) tire traction rating on the tire side wall. Since summer tires do not have the same traction performance as All-season or Snow tires, we do not recommend using summer tires when temperatures drop to about 7°C (45°F) or below, depending on tire wear and environmental conditions, or in snow and ice conditions. Like any tire, summer tire performance is affected by tire wear and environmental conditions. If you must drive in those conditions, we recommend using Mud and Snow (M+S, M/S), All-season or Snow tires.

Always store your summer tires indoors at temperatures above -7°C (19°F). The rubber compounds used in these tires lose flexibility and may develop surface cracks in the tread area at temperatures below -7°C (19°F). If the tires have been subjected to -7°C (19°F) or less, warm them in a heated space to at least 5°C (41°F) for at least 24 hours before installing them on a vehicle, or moving the vehicle with the tires installed, or checking tire inflation. Always inspect the tires after storage periods and before use.

USING WINTER TIRES



We recommend that you use winter or all-season tires carrying this symbol when the temperature is 7°C (45°F) or lower, or in snow and ice conditions.

When using winter tires, install them on all wheels and inflate them to the recommended tire pressures listed on the tire label. See **Inflating the Tires** (page 346).



WARNING: Wheels and tires must be the same size, load index and speed rating as those originally fitted on the vehicle. Use of any other tire or wheel can affect the safety and performance of your vehicle. Additionally, the use of non-recommended tires and wheels can cause steering, suspension, axle, transfer case or power transfer unit failure. Follow the recommended tire inflation pressures found on the Safety Compliance Certification label, or the Tire Label on the B-Pillar or the edge of the driver door. Failure to follow this instruction could result in loss of vehicle control, vehicle rollover, or personal injury or death.

Wheel and Tire Information

USING SNOW CHAINS



WARNING: Do not exceed 50 km/h (30 mph). Failure to follow this instruction could result in the loss of control of your vehicle, personal injury or death.



WARNING: Do not use snow chains on snow-free roads.



WARNING: Only fit snow chains to specified tires.



WARNING: If your vehicle is fitted with wheel trims, remove them before fitting snow chains.



WARNING: Remember that even advanced technology cannot defy the laws of physics. It's always possible to lose control of a vehicle due to inappropriate driver input for the conditions. Aggressive driving on any road condition can cause you to lose control of your vehicle increasing the risk of personal injury or property damage. Activation of the electronic stability control system is an indication that at least some of the tires have exceeded their ability to grip the road; this could reduce the operator's ability to control the vehicle potentially resulting in a loss of vehicle control, vehicle rollover, personal injury and death.



WARNING: Wheels and tires must be the same size, load index and speed rating as those originally fitted on the vehicle. Use of any other tire or wheel can affect the safety and performance of your vehicle. Additionally, the use of non-recommended tires and wheels can cause steering, suspension, axle, transfer case or power transfer unit failure. Follow the recommended tire inflation

pressures found on the Safety Compliance Certification label, or the Tire Label on the B-Pillar or the edge of the driver door. Failure to follow this instruction could result in loss of vehicle control, vehicle rollover, or personal injury or death.

The tires on your vehicle could have all-weather treads to provide traction in rain and snow. In some climates you need to use snow tires and chains on your vehicle in emergency situations or if required by law.

Note: *The suspension insulation and bumpers help prevent vehicle damage. Do not remove these components from your vehicle when using snow tires and chains.*

Note: *Driving too fast for road conditions creates the possibility of loss of vehicle control. Driving at very high speeds for extended periods of time may result in damage to vehicle components.*

Note: *Snow chains could damage aluminum wheels.*

Follow these guidelines when using snow tires and chains:

- On non-GT models, use ultra low profile cables, 10 mm or less in dimension as measured on the sidewall of your tire, only with 225/60R18 or 225/55R19 all season tires.
- On GT models, use ultra low profile cables, 10 mm or less in dimension as measured on the sidewall of your tire, only with 225/55R19 all season tires.
- Do not use snow chains or cables with 245/45R20.
- Not all S-class snow chains or cables meet the same restrictions. Chains of this size restriction include a tensioning device.

Wheel and Tire Information

- Purchase chains or cables from a manufacturer that clearly labels body to tire dimension restrictions.
- Install snow chains or cables in pairs on the rear tires only.
- When driving with snow chains do not exceed 50 km/h (30 mph) or the maximum speed recommended by the chain manufacturer, whichever is less.
- Install cables securely, verifying that the cables do not touch any wiring or brake lines.
- Drive cautiously. If you hear the cables rub or bang against the vehicle, stop and retighten them. If this does not work, remove the cables to prevent vehicle damage.
- Remove the tire chains when they are no longer needed. Do not use snow chains on dry roads.

If you have any questions regarding snow chains or cables, contact your authorized dealer.

Tire Care

CHECKING THE TIRE PRESSURES

Safe operation of your vehicle requires that your tires are properly inflated. Every day before you drive, check your tires.

At least once a month and before long trips, inspect each tire and check the tire pressure with a tire gauge. Inflate all tires to the recommended inflation pressure. See **Inflating the Tires** (page 346).

INFLATING THE TIRES



WARNING: Under-inflation is the most common cause of tire failures and may result in severe tire cracking, tread separation or blowout, with unexpected loss of vehicle control and increased risk of injury. Under-inflation increases sidewall flexing and rolling resistance, resulting in heat buildup and internal damage to the tire. It also may result in unnecessary tire stress, irregular wear, loss of vehicle control and accidents. A tire can lose up to half of its air pressure and not appear to be flat!



WARNING: Do not use the tire pressure displayed in the information display as a tire pressure gauge. Failure to follow this instruction could result in personal injury or death.

Use the recommended cold inflation pressure for optimum tire performance and wear. Under-inflation or over-inflation may cause uneven treadwear patterns.

Inflate your tires to the recommended inflation pressure even if it is less than the maximum inflation pressure information found on the tire. You can find the tire label with the recommended tire inflation pressure next to the tire size on the B-Pillar or the edge of the driver door.

The recommended tire inflation pressure is also found on the Safety Compliance Certification Label, affixed to either the door hinge pillar, door-latch post, or the door edge that meets the door-latch on the B-pillar, or on the edge of the driver door.

Failure to follow the tire pressure recommendations can cause uneven treadwear patterns and adversely affect the way your vehicle handles.

TIRE PRESSURE SPECIFICATIONS

The recommended tire inflation pressures are on the tire information label on the driver side B-pillar.

Check all tire pressures when they are cold, at least once every two weeks.

Tire Care

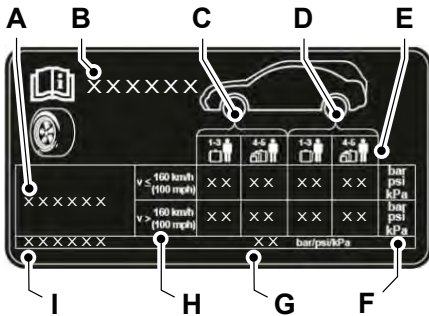

- A Tire size.
- B Vehicle model.
- C Front tire pressure.
- D Rear tire pressure.
- E Vehicle load.
- F Measure unit.
- G Spare wheel tire pressure.
- H Intended constant vehicle speed.
- I Spare wheel tire size.

E254054

Tire size	Normal load		Full load or trailer tow up to 60 mph/100 km/h	
	Front	Rear	Front	Rear
225/60 R18 ¹	2.4 bar (35 psi)	2.8 bar (41 psi)	2.5 bar (36 psi)	3.4 bar (49 psi)
225/55 R19	2.4 bar (35 psi)	2.8 bar (41 psi)	2.5 bar (36 psi)	3.4 bar (49 psi)
245/45 R20	2.7 bar (39 psi)	2.6 bar (38 psi)	2.8 bar (41 psi)	3.4 bar (49 psi)

¹ Only fit snow chains to specified tires.

Tire Care

TIRE ROTATION



WARNING: If the tire label shows different tire pressures for the front and rear tires and the vehicle has a tire pressure monitoring system, then you need to update the settings for the system sensors. Always perform the system reset procedure after tire rotation. If you do not reset the system, it may not provide a low tire pressure warning when necessary.

Rotating your tires at the recommended interval will help your tires wear more evenly, providing better tire performance and longer tire life.

Note: *If your tires show any uneven wear have the alignment checked by an authorized dealer before rotating tires.*

Note: *If you have a dissimilar spare wheel and tire assembly, it is intended for temporary use only and should not be used in a tire rotation.*

Note: *After having your tires rotated, inflation pressure must be checked and adjusted to the vehicle requirements.*

Tire Rotation Diagram

Follow the diagram indicating the correct tire locations for rotating the tires.

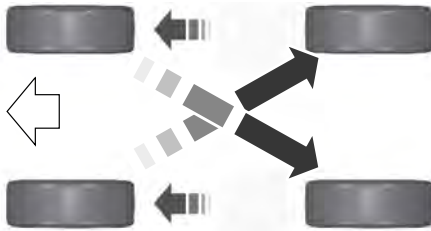

Tire Sealant and Inflator Kit

WHAT IS THE TIRE SEALANT AND INFLATOR KIT

The kit consists of an air compressor to re-inflate the tire and a canister of sealing compound that effectively seals most punctures. This kit provides a temporary tire repair allowing you to drive your vehicle up to 200 km (120 mi) at a maximum speed of 80 km/h (50 mph) to reach a tire service location.

Note: *The temporary mobility kit contains enough sealant compound in the canister for one tire repair only. See an authorized dealer for replacement sealant canisters.*

TIRE SEALANT AND INFLATOR KIT PRECAUTIONS



WARNING: Depending on the type and extent of tire damage, some tires can only be partially sealed or not sealed at all. Loss of tire pressure can affect vehicle handling, leading to loss of vehicle control.



WARNING: Do not use the kit on a previously damaged tire, for example when it has been driven under inflated. This could cause loss of vehicle control, personal injury or death.

Do not attempt to repair punctures larger than 6 mm (0.24 in) or damage to the tire's sidewall.

Only punctures located within the tire tread can be sealed with the kit.

Only use the kit supplied with your vehicle.

The temporary mobility kit contains enough sealant compound in the canister for one tire repair only.

After using the sealant, an authorized dealer needs to replace the tire pressure monitoring system sensor and valve stem on the wheel.

LOCATING THE TIRE SEALANT AND INFLATOR KIT

The kit is located under the load floor in the rear of the vehicle.

TIRE SEALANT AND INFLATOR KIT COMPONENTS

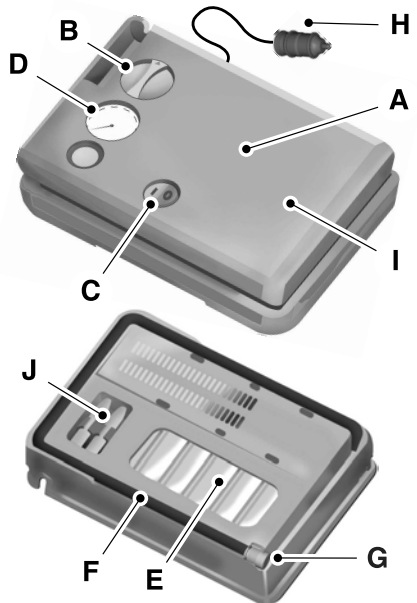

- A Air compressor (inside)
- B Selector switch
- C On and Off button

Tire Sealant and Inflator Kit

- D Air pressure gauge
- E Sealant bottle and canister
- F Dual purpose hose: air and repair
- G Tire valve connector
- H Accessory power plug
- I Casing/housing
- J Bike/raft/sports ball adapters

USING THE TIRE SEALANT AND INFLATOR KIT

Tips for use of the kit

To make sure the kit operates safely and properly, observe the following:

- Before operating the kit, make sure your vehicle is safely off the road and away from moving traffic.
- Do not remove any foreign objects, such as nails or screws, from the tire.
- Do not allow the compressor to operate continuously for more than 15 minutes. This prevents the compressor from overheating.
- Only use the kit when the ambient temperature is between -30°C (-22°F) and 70°C (158°F).
- Only use the sealing compound before the use-by date. The use-by date is on a label on the sealant canister and can be seen through the rectangular viewing window on the bottom of the compressor. Check the use-by date regularly and replace the canister when the sealant expires.

Note: Sealant compound contains latex. Use appropriate precautions to avoid any allergic reactions.



Place the selector in the Air position when inflating a tire or other objects.

What to do when a tire is punctured

A tire puncture within the tire's tread area can be repaired in two stages with the kit.

- In the first stage, the tire is reinflated with a sealing compound and air. After the tire has been inflated, drive the vehicle a short distance approximately 6 km (4 mi) to distribute the sealant in the tire.
- In the second stage, check the tire pressure and adjust, if necessary, to the vehicle's specified tire inflation pressure.

First Stage: Reinflating the Tire with sealing compound and air



WARNING: Do not stand directly over the kit while inflating the tire. If you notice any unusual bulges or deformations in the tire's sidewall during inflation, stop and call roadside assistance.



WARNING: If the tire does not inflate to the recommended tire pressure within 15 minutes, stop and call roadside assistance.

Park the vehicle in a safe, level and secure area, away from moving traffic.

Turn the hazard lights on. Apply the parking brake and power off the vehicle. Inspect the flat tire for visible damage.

If a puncture is located in the tire sidewall, stop and call roadside assistance.

1. Remove the valve cap from the tire valve.
2. Unwrap the dual purpose hose (black tube) from the back of the compressor housing.

Tire Sealant and Inflator Kit

3. Fasten the hose to the tire valve by turning the connector clockwise. Tighten the connection securely.

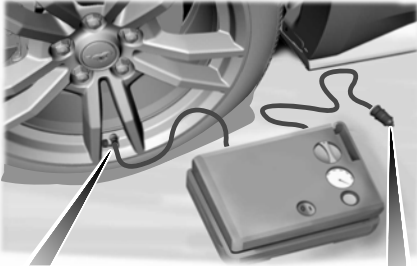

4. Plug the power cable into the 12-volt power point in the vehicle.
5. Remove the warning sticker found on the casing/housing and place it on the top of the instrument panel or the center of the dash.

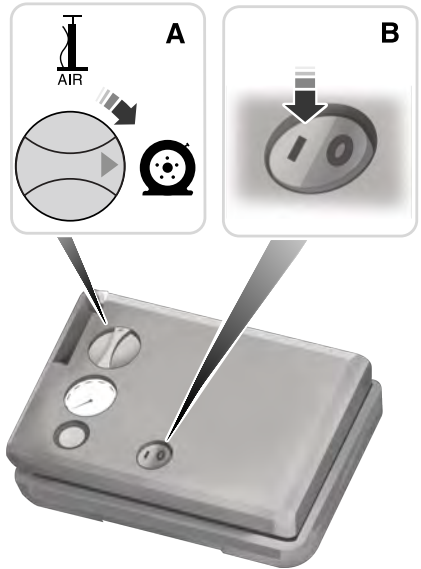

6. Turn dial (A) clockwise to the sealant position. Turn the kit on by pressing the on/off button (B).
7. Inflate the tire to the pressure listed on the tire label located on the driver door or the door jamb area. Check the final tire pressure with the compressor turned off to get an accurate pressure reading.

Tire Sealant and Inflator Kit

Second Stage: Checking the tire pressure with the inflator kit

 **WARNING:** If the tire does not inflate to the recommended tire pressure within 15 minutes, stop and call roadside assistance.

 **WARNING:** The power plug may get hot after use and should be handled carefully when unplugging.

Check the air pressure of your tires as follows:

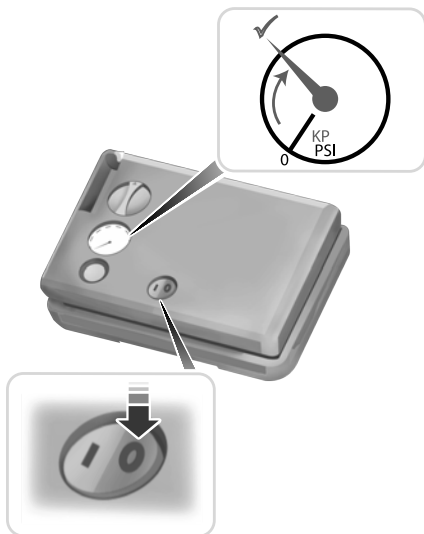

8. When the recommended tire pressure is reached, turn off the kit, unplug the power cable, and disconnect the hose from the tire valve. Re-install the valve cap on the tire valve and return the kit to the rear of the vehicle.
9. Drive the vehicle 6 km (4 mi) to distribute the sealant evenly inside the tire.

Note: *If you experience any unusual vibration, ride disturbance or noise while driving, reduce your speed until you can safely pull off to the side of the road to call for roadside assistance. Do not proceed to the second stage of this operation.*

1. Remove the valve cap from the tire valve.
2. Firmly screw the air compressor hose onto the valve stem by turning clockwise.
3. Push and turn the dial clockwise to the air position.
4. If required, turn on the compressor and adjust the tire to the recommended inflation pressure.
5. Unplug the hoses, re-install the valve cap on the tire and return the kit to the rear of the vehicle.

Tire Sealant and Inflator Kit

What to do after the tire has been sealed

After using the kit to seal your tire, replace the sealant canister. Sealant canisters and spare parts can be obtained at an authorized dealer. Empty sealant canisters may be disposed of at home. However, canisters still containing liquid sealant should be disposed of in accordance with local waste disposal regulation.

Removal of the sealant canister from the kit

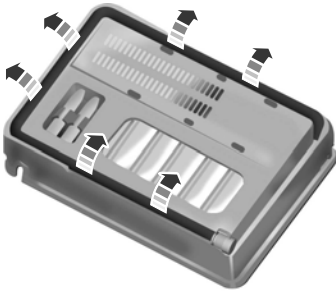

1. Unwrap the dual purpose hose (black tube) from the compressor housing.



2. Unwrap the power cord.



3. Remove the back cover.



4. Rotate the sealant canister up 90 degrees and pull away from casing/housing to remove.

Installation of the sealant canister to the kit

1. With the canister held perpendicular to the housing, insert the canister nozzle into the connector and push until seated.
2. Rotate the canister 90 degrees down into the housing/casing.

Tire Sealant and Inflator Kit



3. Snap the back cover back into place.



4. Wrap the dual purpose hose (black tube) around the channel on the bottom of the housing/casing.

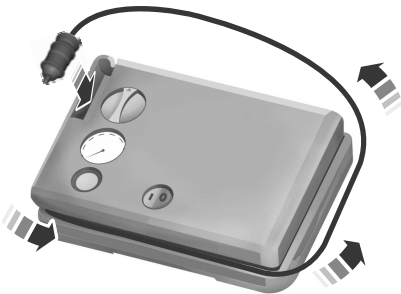

5. Wrap the power cord around the housing and stow the accessory power plug.

Tire Pressure Monitoring System

WHAT IS THE TIRE PRESSURE MONITORING SYSTEM



The tire pressure monitoring system measures the vehicle's tire pressures. A warning lamp illuminates if one or more tires are significantly underinflated or if there is a system malfunction.

TIRE PRESSURE MONITORING SYSTEM PRECAUTIONS



WARNING: The tire pressure monitoring system is not a substitute for manually checking tire pressures. You should periodically check tire pressures using a pressure gauge. Failure to correctly maintain tire pressures could increase the risk of tire failure, loss of control, vehicle rollover and personal injury.



WARNING: Do not use the tire pressure displayed in the information display as a tire pressure gauge. Failure to follow this instruction could result in personal injury or death.

Note: *The use of tire sealants can damage the tire pressure monitoring system.*

Note: *If the tire pressure monitor sensor becomes damaged it may not function.*

TIRE PRESSURE MONITORING SYSTEM LIMITATIONS

When the outside temperature drops significantly, the tire pressure could decrease and activate the low tire pressure warning lamp.

The warning lamp could also illuminate when you use a spare wheel, or tire sealant from the inflator kit.

Note: *Regularly checking the vehicle tire pressures can reduce the possibility for the warning lamp to illuminate due to outside air temperature changes.*

Note: *After you inflate the tires to the recommended pressure it could take up to two minutes of driving over 32 km/h (20 mph) for the warning indicator to turn off.*

VIEWING THE TIRE PRESSURES



To view the current tire pressures, use the information display or touchscreen.

RESETTING TIRE PRESSURE MONITORING SYSTEM

You must carry out the system reset procedure after each tire replacement or adjustment of the tire pressures.

Tire Pressure Monitoring System

To maintain your vehicle load carrying capability, your vehicle may require different tire pressures in the front compared to the rear. In these cases, the system illuminates the warning lamp at different pressures for the front and rear tires.

If the tires are rotated, you need to reset the system in order to relearn the positions of the tire pressure sensors. The system cannot tell which position a tire pressure sensor is in, and assumes you have set the tire pressures correctly.

Performing the Reset Procedure

1. Switch the ignition on.
2. Navigate to the tire monitor menu in the information display. See **Tire Pressure Monitoring System – Information Messages** (page 357).

3. Press and hold the OK button until a confirmation message appears. If your vehicle has a tire pressure monitoring system reset button, press and hold the button until a confirmation message appears.

TIRE PRESSURE MONITORING SYSTEM – TROUBLESHOOTING

TIRE PRESSURE MONITORING SYSTEM – WARNING LAMPS



The low tire pressure warning lamp has combined functions, as it warns you when your tires need air, and when the system is no longer capable of functioning as intended.

Warning Lamp	Possible Cause	Action Required
Solid warning lamp	One or more tires are significantly under inflated	After inflating your tires to the manufacturer's recommended pressure as shown on the tire label, on the edge of driver door or the B-pillar, drive your vehicle for at least two minutes over 32 km/h (20 mph) before the light turns off.
Solid warning lamp or flashing warning lamp	Temporary spare wheel in use	Repair the damaged road wheel and tire and refit it to your vehicle to restore operation of the system.
	Tire pressure monitoring system malfunction	If the tires are inflated to the recommended tire pressures and the temporary spare wheel is not in use, the system detected a fault that requires service. Have your vehicle checked as soon as possible.

Tire Pressure Monitoring System

TIRE PRESSURE MONITORING SYSTEM – INFORMATION MESSAGES

Message	Action
Tyre pressure low	After inflating your tires to the manufacturer's recommended pressure as shown on the tire label, on the edge of the driver door or the B-pillar, drive your vehicle for at least two minutes over 32 km/h (20 mph) before the light turns off.
Tyre pressure monitor malfunction	The system has detected a fault that requires service. Have your vehicle checked as soon as possible.
Tyre pressure sensor malfunction	The system has detected a fault that requires service or a spare tire is in use. Have your vehicle checked as soon as possible.

Changing a Road Wheel

WHEEL NUTS



WARNING: When you install a wheel, always remove any corrosion, dirt or foreign materials present on the mounting surfaces of the wheel or the surface of the wheel hub, brake drum or brake disc that contacts the wheel. Make

sure to secure any fasteners that attach the rotor to the hub so they do not interfere with the mounting surfaces of the wheel. Installing wheels without correct metal-to-metal contact at the wheel mounting surfaces can cause the wheel nuts to loosen and the wheel to come off while your vehicle is in motion, resulting in loss of vehicle control, personal injury or death.

Bolt Size	Nm (lb.ft) ¹
M14 x 1.5	204 Nm (150 lb.ft)

¹ Torque specifications are for nut and bolt threads free of dirt and rust. Use only our recommended replacement fasteners.

Retighten the lug nuts to the specified torque within 160 km (100 mi) after any wheel disturbance, such as tire rotation, changing a flat tire or wheel removal.



A Hub pilot bore.

Inspect the wheel pilot hole and mounting surface prior to installation. Remove any visible corrosion or loose particles.

Capacities and Specifications

VEHICLE DIMENSIONS

Dimension Description	Specification
Overall length excluding the license plate bracket.	4,713 mm (185.6 in)
Overall length including the license plate bracket.	4,728 mm (186.1 in)
Overall width including the exterior mirrors.	2,097 mm (82.6 in)
Overall height.	1,624 mm (63.9 in)
Wheelbase.	2,984 mm (117.5 in)

Capacities and Specifications

COOLING SYSTEM CAPACITY AND SPECIFICATION

Use coolant that meets the defined specification.

If you do not use coolant that meets the defined specification, it could result in:

- Component damage that your vehicle warranty does not cover.
- Reduced vehicle performance.
- Reduced range.

HV Battery Cooling Loop

Capacities

Variant	Quantity
4P battery.	9.03 L (9.54 qt)
3P battery.	8.11 L (8.57 qt)

Materials

Name	Specification
Antifreeze	WSS-M97B57-A2

Motor and Electronics Cooling Loop

Capacities

Variant	Quantity
Rear-Wheel drive.	5.74 L (6.07 qt)
All-Wheel drive.	6.62 L (7.00 qt)

Materials

Name	Specification
Antifreeze	WSS-M97B57-A2

Capacities and Specifications

AIR CONDITIONING SYSTEM CAPACITY AND SPECIFICATION



WARNING: The air conditioning refrigerant system contains refrigerant under high pressure. Only qualified personnel should service the air conditioning refrigerant system. Opening the air conditioning refrigerant system

can cause personal injury.

Use refrigerant and oil that meets the defined specifications.

If you do not use refrigerant and oil that meets the defined specifications, it could result in:

- Component damage that your vehicle warranty does not cover.
- Reduced vehicle performance.
- Reduced range.

Capacities

Variant	Refrigerant	Refrigerant Oil
All.	0.6 kg (21 oz)	140 ml (4.7 fl oz)

Materials

Name	Specification
Refrigerant - R-1234yf	WSS-M17B21-A
A/C Compressor Oil DE-BEV DU7J-M2C31-BA	WSS-M2C31-B2

WASHER FLUID SPECIFICATION

Capacities

Variant	Quantity
All.	Fill as required.

Materials

Name	Specification
Screen Wash FU7J-19C544-AA/BA/DA/EA/GA/HA	WSS-M14P19-A

Capacities and Specifications

BRAKE FLUID SPECIFICATION

Use fluid that meets the defined specification and viscosity grade.

If you do not use fluid that meets the defined specification and viscosity grade, it could result in:

- Component damage that your vehicle warranty does not cover.
- Reduced brake performance.

Note: *We recommend you use Dot 4 Low Viscosity (LV) High Performance Brake Fluid meeting WSS-M6C65-A2 specifications or ISO 4925 Class 6 standards. If you use any fluid other than the recommended fluid, it could cause reduced brake performance and not meet our performance standards. Keep brake fluid clean and dry. Contamination with dirt, water, petroleum products or other materials could result in brake system damage and possible failure.*

Capacities

Variant	Quantity
All.	Fill as required.

Materials

Name	Specification
Brake Fluid DOT 4 LV High Performance BU7J-M6C65-xxxx	WSS-M6C65-A2

Vehicle Identification

VEHICLE IDENTIFICATION NUMBER

LOCATING THE VEHICLE IDENTIFICATION NUMBER

You can find the vehicle identification number at the following locations.

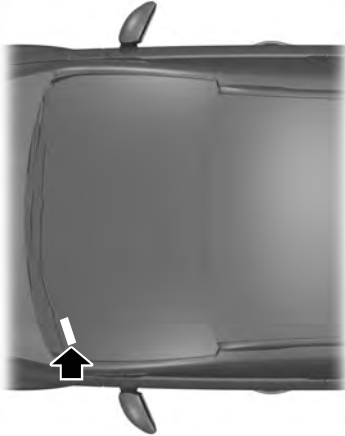

E163915

On the left-hand side of the instrument panel.

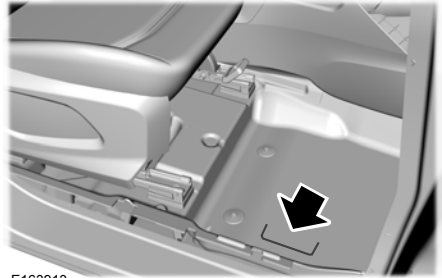

E163913

Stamped into the floor panel on the right-hand side, in front of the front seat.

VEHICLE IDENTIFICATION PLATE

LOCATING THE VEHICLE IDENTIFICATION PLATE

The vehicle identification plate is within the right-hand door aperture.

VEHICLE IDENTIFICATION PLATE OVERVIEW

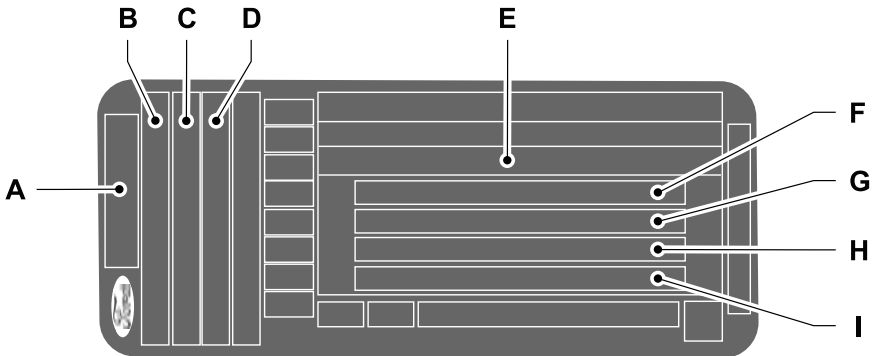

Vehicle Identification

- A Model.
- B Variant.
- C Engine designation.
- D Engine power and emission level.
- E Vehicle identification number.
- F Gross vehicle weight.
- G Gross train weight.
- H Maximum front axle weight.
- I Maximum rear axle weight.

Note: The vehicle identification plate may vary to that shown.

Note: Information on the vehicle identification plate is dependent upon market requirements.

INSTALLING THE VEHICLE IDENTIFICATION CARD

Install any devices that use radio frequency identification, for example, toll readers or vehicle identification cards, to the specified area on the windshield.

Note: Follow the vehicle identification card provider's installation instructions.

Note: When installing the radio frequency identification device, do not block objects such as the rain sensor and the auto-dimming sensor.

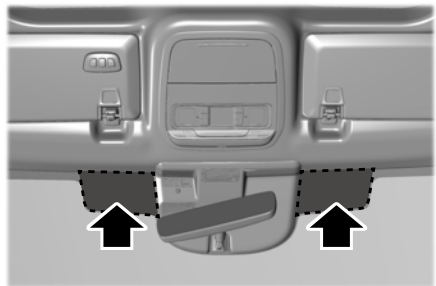

1. Place the device on the windshield, within one of the shaded areas at either side of the mirror.

Note: The device must be placed in the defined areas shown. The remainder of the windshield has a coating that prevents the device from working properly.

Connected Vehicle

WHAT IS A CONNECTED VEHICLE

A connected vehicle has technology that allows your vehicle to connect to a mobile network and for you to access a range of features. When used in conjunction with the FordPass app, it could allow you to monitor and control your vehicle further, for example checking the tire pressures, and the vehicle location. For additional information, refer to the local Ford website.

CONNECTED VEHICLE REQUIREMENTS

Connected service and related feature functionality requires a compatible vehicle network.

Some remote features require additional service activation. Log in to your Ford account for details. Some restrictions, third party terms and message or data rates may apply.

CONNECTED VEHICLE LIMITATIONS

Evolving technology, cellular networks, or regulations could affect functionality and availability, or continued provision of some features. These changes could even stop some features from functioning.

CONNECTING THE VEHICLE TO A MOBILE NETWORK

WHAT IS THE MODEM



The modem allows access to a range of features built into your vehicle.

ENABLING AND DISABLING THE MODEM

-  Press the button on the touchscreen.
- Press **Connectivity**.
- Press **Connected Vehicle Features**.
- Switch vehicle connectivity on or off.

CONNECTING FORDPASS TO THE MODEM

- Make sure that the modem is enabled using the vehicle settings menu.
- Open the FordPass app on your device and log in.
- Add your vehicle or select your vehicle if already added.
- Select the option to activate your vehicle.
- Make sure that the name on the screen matches the name shown in your FordPass account.
- Confirm that FordPass account is connected to the modem.

CONNECTING THE VEHICLE TO A WI-FI NETWORK

-  Press the button on the touchscreen.
- Press **Connectivity**.
- Press **Manage Wi-Fi Networks**.
- Switch **Wi-Fi** on.
- Press **View available networks**.
- Select an available Wi-Fi network.

Note: Enter the network password to connect to a secure network.

Connected Vehicle

CONNECTED VEHICLE – TROUBLESHOOTING

CONNECTED VEHICLE – FREQUENTLY ASKED QUESTIONS - VEHICLES WITH: MODEM

Why can I not confirm the connection of my FordPass account to the modem?

- The modem is not enabled. Switch vehicle connectivity on.
- The network signal is weak. Move your vehicle closer to a place where the network signal is not obstructed.

CONNECTED VEHICLE – FREQUENTLY ASKED QUESTIONS - VEHICLES WITH: SYNC 4

Why can I not confirm the connection of my FordPass account to the modem?

- The modem is not enabled. Switch vehicle connectivity on.
- The network signal is weak. Move your vehicle closer to a place where the network signal is not obstructed.

Why can I not connect to a Wi-Fi network?

- You entered the wrong network password. Enter the correct password.
- The network signal is weak. Move your vehicle closer to the Wi-Fi router or to a place where the network signal is not obstructed.
- There are multiple access points in range with the same network name. Choose a unique name for your network. Do not use the default name unless it contains a unique identifier, for example as part of the MAC address.

Why does the Wi-Fi connection disconnect after successful connection?

- The network signal is weak. Move your vehicle closer to the Wi-Fi router or to a place where the network signal is not obstructed.

What can I do if I am close to a Wi-Fi router but the network signal strength is weak?

- If your vehicle has a heated windshield, position your vehicle so that the windshield is not facing the Wi-Fi router.
- If your vehicle has metallic tinting on the windows but not on the windshield, position your vehicle so that the windshield is facing the Wi-Fi router or open the windows that are facing the router.
- If your vehicle has metallic tinting on the windows and the windshield, open the windows that are facing the router.
- If your vehicle is in a garage and you have the garage door closed, open the garage door as it could block the signal.

Connected Vehicle

Why can I not see a network I expect to see in the list of available networks?

- The network is hidden. Make the network visible and try again, or manually add a network in the Wi-Fi settings menu.
- Some network security types are not supported, for example WEP.

Why do software downloads take too long?

- The network signal is weak. Move your vehicle closer to the Wi-Fi router or to a place where the network signal is not obstructed.
- Wi-Fi network is in high demand or has a slow Internet connection. Use a more reliable Wi-Fi network.

Why does the software not update when the system seems to connect to a Wi-Fi network and the signal strength is excellent?

- No software update is available at this time.
- Select automatic updates option in the settings menu to enable automatic software update or contact an authorized dealer.
- There could be a connection problem. Test the network using another device.

Vehicle Wi-Fi Hotspot

CREATING A VEHICLE WI-FI HOTSPOT

You can create a Wi-Fi hotspot in your vehicle and allow devices to connect to it for access to the Internet.

1.  Press the button on the touchscreen.

2. Press **Connectivity**.
3. Press **Vehicle Hotspot**.

Note: The vehicle hotspot default setting is on.

4. Press Settings under the Vehicle Hotspot menu.
5. Press **Edit**.
6. Switch the Wi-Fi Visibility option on or off.

Note: The Wi-Fi visibility default setting is on.

Finding the Wi-Fi Hotspot Name and Password

1.  Press the button on the touchscreen.

2. Press **Connectivity**.
3. Press **Vehicle Hotspot**.
4. Press Settings under the Vehicle Hotspot menu.

Note: The network name is the hotspot name.

5. Switch the Show Password option on or off.

Connecting a Device to the Wi-Fi Hotspot

1. On your device, switch Wi-Fi on and select the hotspot from the list of available Wi-Fi networks.
2. When prompted, enter the password.

Purchasing a Data Plan

1. Connect a device to the hotspot.

Note: The vehicle network carrier's portal opens on your device.

2. If the portal does not open on your device, open a website and it redirects to the vehicle network carrier's portal.

Note: Secure websites do not redirect.

3. Follow the instructions on the carrier portal to purchase a plan.

Note: If you have an active plan, the system does not redirect to the vehicle network carrier's portal when you connect a device. Visit the vehicle network carrier's website to purchase more data.

Note: If data usage information is available in the vehicle hotspot menu, it is approximate.

Note: If you carry out a master reset, the system does not remove your vehicle from your vehicle network carrier's account. To remove your vehicle from the account, contact your vehicle network carrier.

Note: The vehicle network carrier provides Vehicle Hotspot services, subject to your vehicle network carrier agreement, coverage and availability.

Vehicle Wi-Fi Hotspot

CHANGING THE VEHICLE WI-FI HOTSPOT NAME OR PASSWORD

-  Press the button on the touchscreen.
- Press **Connectivity**.
- Press **Vehicle Hotspot**.
- Press Settings under the Vehicle Hotspot menu.
- Press **Edit**.
- Press **Change Network Name**.
- Enter your required network name.
- Press enter to save the network name.
- Press **Change password**.
- Enter your required password.
- Press enter to save the password.

Changing the Wi-Fi Hotspot Frequency

Note: *The vehicle hotspot frequency band is selectable depending upon your device capabilities. You will not be able to connect your device to the vehicle hotspot if it does not support the selected frequency band.*

-  Press the button on the touchscreen.
- Press **Connectivity**.
- Press **Vehicle Hotspot**.
- Press Settings under the Vehicle Hotspot menu.
- Press **Edit**.
- Select a frequency.

VEHICLE WI-FI HOTSPOT – TROUBLESHOOTING

VEHICLE WI-FI HOTSPOT – FREQUENTLY ASKED QUESTIONS

Why can I not see the Wi-Fi hotspot name when I search for Wi-Fi networks on my cell phone or other device?

- Make sure Wi-Fi hotspot visibility is on.
- The system does not provide a Wi-Fi hotspot at this time.
- Check what frequency the hotspot is transmitting in the vehicle hotspot settings menu. If the frequency is 5 GHz and your device cannot see the network, change the frequency to 2.4 GHz.

Audio System

AUDIO SYSTEM PRECAUTIONS



WARNING: Driving while distracted can result in loss of vehicle control, crash and injury. We strongly recommend that you use extreme caution when using any device that may take your focus off the road. Your primary responsibility is the safe operation of your vehicle. We recommend against the use of any hand-held device while driving and encourage the use of voice-operated systems when possible. Make sure you are aware of all applicable local laws that may affect the use of electronic devices while driving.

Listening to loud audio for long periods of time could damage your hearing.

SWITCHING THE AUDIO UNIT ON AND OFF



Press the button on the volume control.

SELECTING THE AUDIO SOURCE

1. Press your preferred audio source.

Note: Available audio sources are listed along the top of the radio screen.

PLAYING OR PAUSING THE AUDIO SOURCE



Press to pause playback. Press again to resume playback.

Note: Not all sources can be paused.

ADJUSTING THE VOLUME

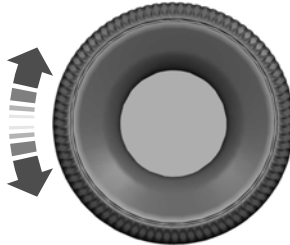

Turn to adjust the volume.

You can also press the mute button on the map screen.

Some vehicles may be able to adjust the volume using buttons on the steering wheel.

SWITCHING SHUFFLE MODE ON AND OFF



Press the button on the touchscreen to switch shuffle mode on or off.

Note: Not all sources have shuffle mode.

SWITCHING REPEAT MODE ON AND OFF



Press the button on the touchscreen to switch repeat mode on or off.

Note: Not all sources have repeat mode.

SETTING A MEMORY PRESET

1. Select a station.

Audio System

2. Press and hold a memory preset button on the touchscreen.

Note: The audio mutes briefly while the system saves the preset and returns once stored.

Note: You can save presets from multiple radio bands to the memory preset bar.

MUTING THE AUDIO



Press to mute the signal. Press again to restore the signal.

ADJUSTING THE SOUND SETTINGS

To access the sound settings menu:

1.  Press the button on the touchscreen.
2. Press **Sound**.

From the menu, you can adjust the following:

- Balance and fade.
- Tone settings.
- Speed compensated volume.
- Volume settings.Occupancy mode.
- Sound mode.

SETTING THE CLOCK AND DATE

1.  Press the button on the touchscreen.
2. Press **General**.
3. Press **Clock**.
4. Set the time.

Note: The **AM** and **PM** options are not available if **24-hour mode** is on.

Switching Automatic Time Updates On and Off

1.  Press the button on the touchscreen.
2. Press **General**.
3. Press **Clock**.
4. Switch **Automatic time zone update** on or off.

FM RADIO

FM RADIO LIMITATIONS

The further you travel from a FM station, the weaker the signal and the weaker the reception.

Hills, mountains, tall buildings, bridges, tunnels, freeway overpasses, parking garages, dense tree foliage and thunderstorms can interfere with the reception.

When you pass a ground-based broadcast repeating tower, a stronger signal may overtake a weaker one and result in the audio system muting.

Audio System

SELECTING AN FM RADIO STATION

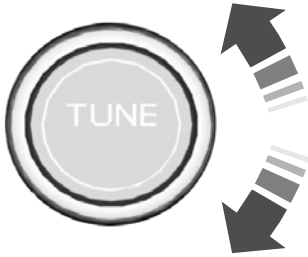

Turn to search through the radio frequency band.

Using Direct Tune

1. Press **Frequency** to open the number pad.
2. Enter the station you prefer.

Note: You can only enter a valid station for the audio source you are currently listening to.

Using Seek



Press either button. The system stops at the first station it finds in that direction.



Using the Station List

1. Press **Stations**.
2. Press a station.

DIGITAL AUDIO BROADCASTING RADIO

WHAT IS DIGITAL AUDIO BROADCASTING RADIO

Digital Audio Broadcasting (DAB) is a digital radio standard for broadcasting digital audio radio services. Your radio allows you to listen to DAB radio stations.

DIGITAL AUDIO BROADCASTING RADIO LIMITATIONS

Coverage differs from region to region and influences the quality of reception. It is broadcast nationwide, regionally and locally. Coverage may vary on weather conditions and terrain.

Note: This could cause the audio to dropout.

WHAT IS SERVICE LINKING

If you leave the coverage area of a DAB radio station the system switches to the corresponding FM radio station if one is available.

SWITCHING SERVICE LINKING ON AND OFF

1.  From the audio screen, press the button.
2. Press **Radio**.
3. Switch **DAB servicelink** on or off.

Audio System

SELECTING A DIGITAL AUDIO BROADCASTING RADIO STATION

Manually Selecting a Radio Station



Press the button on the radio tuner to go up the frequency band.



Press the button on the radio tuner to go down the frequency band.

Using Seek



Press to seek the next station up the frequency band.

Press and hold to quickly seek up the frequency band.



Press to seek the next station down the frequency band.

Press and hold to quickly seek down the frequency band.

Selecting a Radio Station From a List

1. Press the search button on the radio screen.
2. Press a radio station from the list.

DIGITAL AUDIO BROADCASTING RADIO SETTINGS

Slideshow

When switched on and available, the touchscreen displays supplied pictures in place of the station logo. The pictures can be enlarged by touching them.

Electronic Program Guide

When enabled and available, the touchscreen displays what is currently playing and what plays next on the selected station.

Station Logo

When switched on and available, the touchscreen displays the current FM or DAB station logo.

News Announcements

When switched on, the current playing audio source may be interrupted by news announcements. An icon on the radio screen indicates when news announcements are enabled. An icon in the status bar indicates when an announcement is active.

Regional

When switched on, the radio stays tuned to the selected FM or DAB regional station. When switched off, the radio may tune to a regional alternative of the station depending on reception.

Station List Order

Allows you to order the DAB station list by name or network.

TRAFFIC ANNOUNCEMENTS

SWITCHING TRAFFIC ANNOUNCEMENTS ON AND OFF



Press the button on the radio screen.

Audio System

When switched on, the current playing audio source may be interrupted by traffic announcements. An icon on the radio screen indicates when announcements are enabled. An icon in the status bar indicates when an announcement is active.

Center Display Overview

CENTER DISPLAY PRECAUTIONS



WARNING: Driving while distracted can result in loss of vehicle control, crash and injury. We strongly recommend that you use extreme caution when using any device that may take your focus off the road. Your primary responsibility is the safe operation of your vehicle. We recommend against the use of any hand-held device while driving and encourage the use of voice-operated systems when possible. Make sure you are aware of all applicable local laws that may affect the use of electronic devices while driving.

CENTER DISPLAY LIMITATIONS

Speed-restricted Features

For your safety, some features are not available while the vehicle is in motion at or above 8 km/h (5 mph). Settings that are not critical while driving your vehicle are shown as restricted on your display. Some of these settings include:

- Software updates.
- Personal profiles setup.
- Valet mode setup.
- Driver assistance settings.
- MyKey setup.
- Door keypad code setup.

These restricted features become available when your vehicle is no longer in motion.

STATUS BAR

The bar is on top of the display and indicates the status of your vehicle's features.

Status Area

The status area is on the right side of the status bar and provides information about vehicle features.

Audio System



Audio system muted.

Connected Device



Cell phone microphone muted.



Phone call in progress.



Media player connected using **Bluetooth®**.



Cell phone network signal strength.



Cell phone roaming.



Text message received.



Unread email message.



Automatic crash notification system off.



Cell phone battery status.

Center Display Overview

Vehicle Data



Wi-Fi available.



Wi-Fi connected.



Vehicle data sharing on.



Vehicle data sharing off.



Vehicle location sharing on.



Vehicle data and vehicle location sharing on.

Wireless Accessory Charger



Wireless accessory charger active.

Traffic Announcements



Traffic announcements are turned on but are not supported by the selected station.



Traffic announcements are turned on and supported by the selected station but are not active.



Traffic announcements are active.

Note: If no traffic announcement icons are displayed, traffic announcements are turned off.

Action Area

The action area is on the left side of the status bar and contains status updates that may require your action. Press the icons in the action area to learn more.

Vehicle Software Update

See **Software Update Indicators** (page 392).

CENTER DISPLAY SETTINGS

Valet Mode

Valet mode allows you to lock the system. No information is accessible until the system is unlocked with the correct PIN.

When you select valet mode, a pop up appears informing you that a four digit code must be entered to enable and disable valet mode. You can use any PIN you choose, but you must use the same PIN to disable valet mode. The system asks you to input the code.

Note: If the system is locked and you cannot remember the PIN, please contact the customer relationship center.

To enable valet mode, enter your chosen PIN. The system then asks to confirm your PIN by reentering it. The system then locks.

To unlock the system, enter the same PIN number. The system reconnects to your phone and all of your options are available again.

REBOOTING THE CENTER DISPLAY

You can reboot the center display using the controls on the steering wheel.

1. Simultaneously press and hold the seek forward and volume down button for 10 seconds.

Voice Interaction

FORD ASSISTANT

USING FORD ASSISTANT

The digital assistant allows you to control vehicle features using conversational requests.

To begin a voice interaction using the wake word, say the selected wake word, then say your command.



Press the voice interaction button on the steering wheel. A tone sounds before you can say your command.

Note: You may need to enable your vehicle's modem to use certain voice commands. See **Enabling and Disabling the Modem** (page 365).

Note: When you are not driving, additional commands are available by using popular chat applications. Use FordPass to setup a conversation with your Ford assistant.

Voice Command Examples

To see examples of what voice commands you can use with different features:

1.  Press the button on the touchscreen.
2. Press **Ford Assistant**.
3. Press **Voice Command Help**.
4. Select a feature.

FORD ASSISTANT SETTINGS

To access the settings menu:

1.  Press the button on the touchscreen.
2. Press **Ford Assistant**.

From the settings menu you can do the following:

- Switch listen for wake word on or off.
- Set the preferred wake word.
- Switch advance mode on or off.
- Switch phone confirmation on or off.
- Switch the commands list on or off.
- View the commands help menu.



Press the button next to a menu option for more information.

FORD ASSISTANT – FREQUENTLY ASKED QUESTIONS

Why does the system not understand what I am saying?

- You are speaking too soon. When using the button of the steering wheel, wait for the tone before you speak.

Why does the system not understand the name of a track or artist?

- **Bluetooth®** does not support voice commands. Connect your device to a USB port.
- You are not saying the name exactly as it appears on your device. Say the name of the track or artist exactly as it appears on your device. Spell out any abbreviations in the name.
- The system does not recognize some special characters contained in the name of a song or artist, for example *, - or +. Rename the files on your device or use the touchscreen to select and play the track.

Voice Interaction

Why does the system not understand the name of a contact in the phonebook on my device and calls the wrong contact?

- You are not saying the name exactly as it appears on your device. Say the first and last name of the contact exactly as it appears on your device. Spell out any abbreviations in the name.
- The name contains special characters, for example *, - or +. Rename the contact on your device or use the touchscreen to select and call the contact.

Why does the system not understand foreign names of contacts in the phonebook on my device?

- The system applies phonetic pronunciation rules of the selected language to the names of contacts in the phonebook on your device. Select the name of the contact on the touchscreen and use the Hear it option to get an idea of how the system expects you to pronounce it.

Why do the system voice prompts and the pronunciation of some words not seem accurate?

- The system uses text-to-speech technology and a synthetically generated voice rather than a pre-recorded human voice.

Phone

PHONE PRECAUTIONS



WARNING: Driving while distracted can result in loss of vehicle control, crash and injury. We strongly recommend that you use extreme caution when using any device that may take your focus off the road. Your primary responsibility is the safe operation of your vehicle. We recommend against the use of any hand-held device while driving and encourage the use of voice-operated systems when possible. Make sure you are aware of all applicable local laws that may affect the use of electronic devices while driving.

CONNECTING YOUR PHONE

Connecting your phone stores contact and call data on your vehicle.

Note: *This data is used to provide intelligent suggestions. You can switch this off in the touchscreen settings menu. See **Selecting a Personal Profile** (page 387).*

Note: *Unpairing your phone removes the contact and call data from your vehicle and stops intelligent call suggestions.*

1. Make sure **Bluetooth®** is enabled on your device.

2.



Press the button on the touchscreen.

3. Press **Phone List**.

4. Select **Pair phone**.

5. Follow the instructions on the screen to pair your device.

PHONE MENU



Press to view your favorite contacts.



Press to view your recent calls.



Press to view your contacts



Press to use the phone keypad.



Press to display recent text messages.



Press to view recent emails.

Press the down arrow to view additional items for a connected device.



Press to begin a voice interaction.



Press to switch to a different connected device.



Press to mute notifications.



Press to access phone settings.

Phone

MAKING AND RECEIVING A PHONE CALL

Making Calls

To call a number in your contacts, select:

Menu Item	Action and Description
Contacts	You can then select the name of the contact you want to call. Any numbers stored for that contact display along with any stored contact photos. You can then select the number that you want to call. The system begins the call.

To call a number from your recent calls, select:

Menu Item	Action and Description
Recent Call list	You can then select an entry that you want to call. The system begins the call.

To call a number from your favorites, select:

Menu Item	Action and Description
Favourites	You can then select an entry that you want to call. The system begins the call.

To call a number that is not stored in your phone, select:

Menu Item	Action and Description
Phone Keypad	Select the digits of the number you wish to call.
Call	The system begins the call.

Pressing the backspace button deletes the last digit you typed.

Receiving Calls

During an incoming call, an audible tone sounds. Caller information appears in the display if it is available.

To accept the call, select:

Menu Item
Accept

Note: You can also accept the call by pressing the phone button on the steering wheel.

To reject the call, select:

Menu Item
Reject

Ignore the call by doing nothing. The system logs it as a missed call.

During a Phone Call

During a phone call, the contacts name and number display on the screen along with the call duration.

The phone status items are also visible:

- Signal Strength.
- Battery.

You can select any of the following during an active phone call:

Phone

Item	
End call	Immediately end a phone call. You can also press the button on the steering wheel.
Keypad	Press this to access the phone keypad.

Item	
Mute	You can switch the microphone off so the caller does not hear you.
Hndsfree off	Transfer the phone call audio to the cell phone or back to the touchscreen.

SENDING AND RECEIVING A TEXT MESSAGE

Menu Item	Description
Hear it	Hear the text message.
View	View the text message.
Call	Call the sender.
Reply	Reply to the text message with a standard text message.

Phone

SWITCHING TEXT MESSAGE NOTIFICATION ON AND OFF

IOS

1. Go to the settings menu on your cell phone.
2. Select **Bluetooth®**.
3. Select the information icon to the right of your vehicle.
4. Switch text message notification on or off.

Android

1. Go to the settings menu on your cell phone.
2. Select **Bluetooth®**.
3. Select the profiles option.
4. Select the phone profile.
5. Switch text message notification on or off.

Bluetooth®

CONNECTING A BLUETOOTH® DEVICE

1. Make sure **Bluetooth®** is enabled on your device.
2.  Press the button on the touchscreen.
3. Press **Connectivity**.
4. Press **Bluetooth**.
5. Switch **Bluetooth** on.
6. Press **Add a Bluetooth Device**.

Note: A prompt alerts you to search for your vehicle on your device.

Note: A number appears on your device and on the touchscreen.

Note: The touchscreen indicates that you have successfully paired your device.

The **Bluetooth®** word mark and logos are registered trademarks owned by **Bluetooth SIG, Inc.** and any use of such marks by Ford Motor Company is under license. Other trademarks and trade names are those of their respective owners.

PLAYING MEDIA USING BLUETOOTH®



WARNING: Driving while distracted can result in loss of vehicle control, crash and injury. We strongly recommend that you use extreme caution when using any device that may take your focus off the road. Your primary responsibility is the safe operation of your vehicle. We recommend against the use of any

hand-held device while driving and encourage the use of voice-operated systems when possible. Make sure you are aware of all applicable local laws that may affect the use of electronic devices while driving.

1. Connect your device to Bluetooth®
2.  Press the button on the touchscreen. See **Accessing Apps** (page 384).



Press to play a track. Press again to pause the track.



Press to skip to the next track. Press and hold to fast forward through the track.



Press once to return to the beginning of a track. Repeatedly press to return to previous tracks.

Press and hold to fast rewind through the track.

Browsing your Media Library

When a compatible mobile device is connected to the vehicle, your media library accessible through the touchscreen. From the touchscreen, you can browse through songs, albums, artists, and playlists on your mobile device.

Note: This feature is dependent on the connected mobile device and the media application used.

Note: Browse feature functionality may be limited while driving.

Apps

APP PRECAUTIONS



WARNING: Driving while distracted can result in loss of vehicle control, crash and injury. We strongly recommend that you use extreme caution when using any device that may take your focus off the road. Your primary responsibility is the safe operation of your vehicle. We recommend against the use of any hand-held device while driving and encourage the use of voice-operated systems when possible. Make sure you are aware of all applicable local laws that may affect the use of electronic devices while driving.

APP REQUIREMENTS

When you start an app through the system for the first time, you could be asked to grant certain permissions. You can review and change the permissions that you have granted at any time when your vehicle is not moving. We recommend that you check your data plan before using your apps through the system. Using them could result in additional charges. We also recommend that you check the app provider's terms and conditions and privacy policy before using their app. Make sure that you have an active account for apps that you want to use through the system. Some apps will work with no setup. Others require you to configure some personal settings before you can use them.

ACCESSING APPS



Press the button on the touchscreen to open the application drawer.



A Application area.

B Card area.

Application Area

This is the main app area where apps are launched and you can utilize the full functionality of the chosen app.

Card Area

Here you can see recently used applications with limited content. When you select one of these cards, the app will display in the application area with full functionality.

ENABLING APPS ON AN IOS DEVICE

1. Follow the instructions to pair and connect your device via **Bluetooth®** or with a USB cable.

Note: Some apps may run through CarPlay if it is enabled.

2. Start a compatible app on your device.

Apps

Note: The app must be open on your device to use it through the touchscreen.

3. Access the system applications.
4. Select the app you wish to use on the touchscreen.
3. Press **Phone List**.
4. Select your device.
5. Select the connect option.
6. Switch **Android Auto** on or off.

ENABLING APPS ON AN ANDROID DEVICE

1. Pair your device to **Bluetooth®**.

Note: Some apps may run through Android Auto if it is enabled.

2. Start a compatible app on your device.
- Note:** The app must be open on your device to use it through the touchscreen.
3. Access the system applications.
 4. Select the app you wish to use on the touchscreen.

SWITCHING APPLE CARPLAY ON AND OFF

1. Pair your device.

2.  Press the button on the touchscreen.

3. Press **Phone List**.
4. Select your device.
5. Select the connect option.
6. Switch **Apple Carplay** on or off.

SWITCHING ANDROID AUTO ON AND OFF

1. Pair your device.

2.  Press the button on the touchscreen.

Personal Profiles

HOW DO PERSONAL PROFILES WORK

You can create multiple personal profiles enabling users to personalize vehicle settings such as seats and mirrors, as well as non-positional settings like radio, navigation and driver assist system settings. Positional settings are saved by holding a memory seat button. Non-positional settings are saved when you change a setting while a profile is active.

ENABLING OR DISABLING PERSONAL PROFILES

1.  Press the profile button on the touchscreen.

Note: *The button image may vary when a profile is selected.*

2. Switch Personal Profiles on or off.

When enabled:

- Unlocking a door with a remote control or mobile device that is not linked to a driver profile does not change active profile, but remains in the last known profile. It does not change the positional settings.
- Pressing a memory seat button that is not linked to a driver profile or saved to a preset setting does not change active profile, but remains in the last known profile. It does not change the positional settings.
- Pressing a memory seat button that is not linked to a driver profile but is saved to a preset setting does not change active profile, but remains in the last known profile. It recalls the positional settings that you saved to that memory seat button.

When disabled:

- Unlocking a door with a remote control or mobile device does not recall any non-positional settings but still recalls positional settings from the driver profile which the remote control or mobile device is linked to.
- Pressing a memory seat button that is not linked to a driver profile or saved to a preset setting recalls non-positional settings from the guest profile. It does not change the positional settings.
- Pressing a memory seat button that is linked to a driver profile or has saved to a preset setting recalls non-positional settings from the guest profile. It recalls the positional settings that you saved to that memory seat button.

CREATING A PERSONAL PROFILE

1. Switch the vehicle on and leave the vehicle in park (P).

2.  Press the profile button on the touchscreen.

Note: *The button image may vary when a profile is selected.*

3. Press Add New.
4. Follow the instructions on the display.

LINKING OR UNLINKING A PERSONAL PROFILE

You can link your profile to a remote control or mobile device so that your settings are activated when you use the remote control or mobile device to turn on the vehicle.

Personal Profiles

Remote Control

You can save preset memory positions for up to three remote controls by assigning a remote control to a personal profile.

1.  Press the profile button on the touchscreen.

Note: *The button image may vary when a profile is selected.*

2. Select the profile to link or unlink.

Note: *You cannot link a remote control to a guest profile.*

3. Select the remote control to link or unlink.
4. Follow the instructions on the touchscreen.

Note: *If more than one linked remote control is in range, the memory function moves to the settings of the first key to initiate a memory recall.*

Mobile Device

1.  Press the profile button on the touchscreen.

Note: *The button image may vary when a profile is selected.*

2. Select the profile to link or unlink.

Note: *You cannot link a mobile device to a guest profile.*

3. Select the mobile device to link or unlink.

Note: *The mobile device must be in your vehicle and previously set up as a remote control for your vehicle.*

4. Follow the instructions on the touchscreen.

Note: *If more than one linked mobile device is in range, the memory function moves to the settings of the first mobile device to initiate a memory recall.*

SELECTING A PERSONAL PROFILE

You can select a profile using the touchscreen or the preset button you selected when you created your profile.

If you use a linked device, such as a remote control or mobile device, the active profile is set to the linked profile.

To change the active profile:

1.  Press the profile button on the touchscreen.

Note: *The button image may vary when a profile is selected.*

2. Select the profile to use.
3. Press Make Profile Active.

DELETING A PERSONAL PROFILE

1.  Press the profile button on the touchscreen.

Note: *The button image may vary when a profile is selected.*

2. Select the profile to delete.
3. Press Delete Profile.

Navigation

CONNECTED NAVIGATION (IF EQUIPPED)

Your vehicle may be equipped with connected navigation. Depending on your version, you are given a 90 day or 3 year trial. After the trial period, you need to sign up to continue the experience. For additional information, visit ford.com/connectedservices.

Note: *If you do not sign up or renew your subscription, you can still use navigation through a connected device.*

ACCESSING NAVIGATION

-  Press the button on the touchscreen to open the application drawer.

- Press **Navigation**.

Note: *As the driver, be aware of all local traffic regulations and road attributes, and operate your vehicle in a safe and legal manner.*

NAVIGATION MAP UPDATES

To update your Map data over Wi-Fi, your vehicle must be connected to a Wi-Fi access point. For USB updates and other details, contact an authorized Ford dealer.

Note: *If you find map data errors, you may report them by going to www.here.com/mapcreator.*

ADJUSTING THE MAP

ZOOMING THE MAP IN AND OUT

You can use pinch gestures to zoom in and out. Place two fingers on the screen and move them apart to zoom in. Place two fingers on the screen and bring them together to zoom out.

CHANGING THE FORMAT OF THE MAP



Press the map format button on the left side of the map screen to toggle between the available formats.

LIVE TRAFFIC

WHAT IS LIVE TRAFFIC

You can observe real-time road congestion when live traffic is on.

SWITCHING LIVE TRAFFIC ON AND OFF

- Press the tools button on the map screen.
- Press Navigation Settings.
- Press the Traffic button.
- Switch Traffic on or off.

SETTING A DESTINATION

SETTING A DESTINATION USING THE TEXT ENTRY SCREEN

- Press the search bar at the top of the screen.
- Enter your destination using the keyboard.

Navigation

3. Select a destination from the list.
4. Press Go! to begin navigation.

SETTING A DESTINATION USING THE MAP SCREEN

Press on the map to trigger the roaming and viewing screen. Press on the map again to place a pin at that location. Information about the location of the pin appears on the screen. Press the Go! button to begin navigation to the pin.

SETTING A DESTINATION USING A PREDICTIVE DESTINATION

Switching Predictive Destinations On and Off

You can switch Destination Suggestions on and off under the User Data section in the navigation settings menu.

Setting a Destination

Access the feature bar using the touchscreen and select the predicted destination at the top of the screen. You can access additional predictive destinations by pressing the search bar on the map screen and then pressing the myTrends button.

SETTING A DESTINATION USING A RECENT DESTINATION

1. Press the search bar on the map screen.
2. Press Recents.
3. Select a destination from the list.

SETTING A DESTINATION USING A SAVED DESTINATION

1. Press the search bar at the top of the screen.

2. Press Saved Places.
3. Select a saved destination.

Note: Press the star icon next when viewing location details to save the location.

SETTING A DESTINATION USING A POINT OF INTEREST

Press on a point of interest icon on the map. Information about the location of the point of interest appears on the screen. Press the Go! button to begin navigation to the point of interest.

WAYPOINTS

ADDING A WAYPOINT

1. Begin navigation to a destination.
2. Search for your waypoint using the search bar.
3. Press Go!
4. Press Add to add the waypoint to your trip.

EDITING WAYPOINTS

1. Press the search bar on the map screen.
2. Press myTrips.
3. Press Current Trip.
4. Use the menu to add destinations, remove destinations, or rearrange destinations.

ROUTE GUIDANCE

ADJUSTING THE GUIDANCE PROMPT VOLUME

Turn the volume control when a guidance prompt plays to adjust the volume.

Navigation

REPEATING AN INSTRUCTION

Press the turn indicator to hear the last voice instruction.

CANCELING ROUTE GUIDANCE



Press the button to cancel route guidance to the selected location.

Vehicle Software Updates

This introduces new features and provides updates to the vehicle's software systems. Make sure to switch Automatic Updates on, set a recurring update schedule and connect your vehicle to Wi-Fi. Updates could take longer when not connected to Wi-Fi or could not download at all. See

Connecting the Vehicle to a Wi-Fi Network (page 365). See **Connecting the Vehicle to a Wi-Fi Network** (page 365).

Your vehicle may be able to receive drivable software updates, non-drivable software updates or both. Drivable software updates happen during normal vehicle usage and require limited input from you. You are notified on your touchscreen and connected device prior to a non-drivable update.

Most non-drivable updates complete in less than 30 minutes, although some updates could take up to a few hours.

You are notified of vehicle software update status on to the top left of touchscreen. You can also see the notifications in your connected device. See **Software Update Indicators** (page 392).

Vehicle Software Update Requirements

Non-drivable software updates do not install if any of the following occur:

- Your vehicle is running.
- Your vehicle is switched on.
- Your vehicle is not parked.
- The 12 V battery charge is too low.
- The hazard indicators are switched on.
- The alarm is sounding.
- The doors are open.
- The parking lamps are switched on.
- You are pressing the brake pedal.
- An emergency call is in process.
- Your vehicle is in limp home mode.

Vehicle Software Update Limitations

Once you begin a non-drivable software update, you cannot:

- Cancel the update.
- Enter your vehicle unless you have a key blade.
 - You can open the doors using the mechanical latch if child locks are not on.
- Use the remote control to lock, unlock or start your vehicle.
- Drive your vehicle.
- Charge your vehicle.
 - Charging resumes once the update completes.

SOFTWARE UPDATE SETTINGS

1.  Press the button on the touchscreen.
2. Press **Software Updates**.

You can do the following in the Software Updates menu:

- Switch Automatic Updates on and off.
- Schedule and install software updates.
- View software update details.

1.  Press the button next to a menu option for more information.

Vehicle Software Updates

Switching Automatic Updates On and Off

Your vehicle may come with Automatic Updates switched on. To make sure your vehicle always has the latest software, which could include security or other enhancements, we do not recommend switching Automatic Updates off.

Note: *Software updates require approval to download or install with Automatic Updates switched off.*

Scheduling and Installing Software Updates

Scheduling Software Updates

From the Software Updates menu:

1. Press **Schedule Updates**.
2. Select the days and time for updates.
3. Press **Save**.

The more days that updates are scheduled, the more frequently your vehicle installs new updates. We recommend selecting a time you normally do not need your vehicle, such as overnight.

Some updates require your vehicle to be switched off.

Note: *The schedule you set is recurring. If Automatic Updates is on, every time a non-drivable update is available, it installs on this schedule unless you change it. You are notified on your touchscreen and connected device prior to a non-drivable update, with an option to reschedule it.*

Installing Software Updates

Using the Status Bar

1. Press a Software Update indicator on your touchscreen when it appears.
2. Follow the instructions on the touchscreen.

Using the Touchscreen

From the Software Updates menu:

1. Press **Update Details**.
2. Press **Update Now**.

Viewing Software Update Details

From the Software Updates menu:

1. Press **Update Details**.

SOFTWARE UPDATE INDICATORS

You can press the indicators in the status bar when they appear for more information.



Vehicle software update reminder, schedule required, confirmation of default schedule required, or consent required.



Vehicle software update canceled, update not successful, or precondition not met.



Vehicle software update successful.

Vehicle System Reset

PERFORMING A SYSTEM RESET

Make sure you perform a system reset whenever there is a transfer of ownership of the vehicle to prevent the loss of personal data. Performing a system reset allows you to remove all personal information and restore the modem and SYNC to their factory defaults.

In the modem, this deletes all the authorized users, removes access to the connected vehicle via all linked FordPass accounts. In the SYNC system this deletes all data imported from mobile devices connected to the vehicle via Bluetooth® including the addresses manually entered into the navigation system.

Note: *If you are the first owner, your modem comes in partially activated state.*

Note: *If you are not the first owner, it comes in either fully activated, partially activated or deactivated state.*

1.  Press the button on the touchscreen.
2. Press **General**.
3. Press **Reset**.
4. Press **Factory Reset**.
5. Follow the prompts on the touchscreen to complete the reset.

Customer Information

ROLLOVER WARNING



WARNING: Utility vehicles have a significantly higher rollover rate than other types of vehicles.



WARNING: Vehicles with a higher center of gravity (utility and four-wheel drive vehicles) handle differently than vehicles with a lower center of gravity (passenger cars). Avoid sharp turns, excessive speed and abrupt steering in these vehicles. Failure to drive cautiously increases the risk of losing control of your vehicle, vehicle rollover, personal injury and death.



WARNING: In a rollover crash, an unbelted person is significantly more likely to die than a person wearing a seatbelt.



WARNING: Do not become overconfident in the ability of four-wheel drive vehicles. Although a four-wheel drive vehicle may accelerate better than a two-wheel drive vehicle in low traction situations, it won't stop any faster than two-wheel drive vehicles. Always drive at a safe speed.

Utility vehicles and trucks handle differently than passenger cars in the various driving conditions that are encountered on streets, highways and off-road. Utility vehicles and trucks are not designed for cornering at speeds as high as passenger cars any more than low-slung sports cars are designed to perform satisfactorily under off-road conditions.

THIRD PARTY SOFTWARE COPYRIGHT ACKNOWLEDGMENT

Your vehicle could have components that use open source software. For additional information, visit <http://corporate.ford.com/ford-open-source.html>.

DECLARATION OF CONFORMITY

Your vehicle could have components that transmit and receive radio waves and are therefore subject to government regulation.

These components must accept any interference received, including interference that could cause undesired operation. For certification labels and declarations of conformity, visit www.wirelessconformity.ford.com.

REACH

We are committed to promoting the responsible manufacturing, handling and use of our products and support the underlying goals of **REACH**, a European Union regulation that concerns the registration, evaluation, authorisation and restriction of chemicals.

We specifically support Regulation EC 1907/2006 Article 33(1) that relates to substances of very high concern which appear on the current list for authorisation.

If these substances do exist in a product, it is important to guarantee their safe use so the regulation is designed to enable you to take any appropriate risk management measures.

Customer Information

To find out more about the **REACH** directive, search **REACH** on the local Ford website.

Note: To find the local Ford website, visit <https://corporate.ford.com/operations/locations/global-links.html>.

RADIO FREQUENCY CERTIFICATION LABELS

BLIND SPOT INFORMATION SYSTEM SENSORS

Argentina



Brazil



Djibouti

AGREE PAR LE MCPT (REPUBLIQUE DE DJIBOUTI)
Numéro d'agrément : 195/MCPT/DDTIC
Date d'agrément : 06/09/2021

Europe Union EU

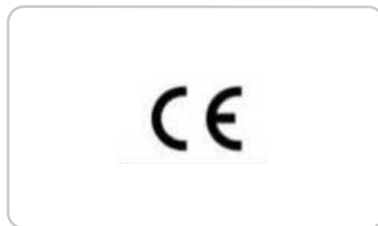

Ghana

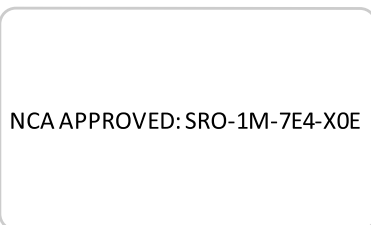

Customer Information

Jamaica

This product has been Type Approved by Jamaica: SMA – FSTR.

IFETEL: RCPAPF520-0480

Morocco

AGREE PAR L'ANRT MAROC
Nu méro d'agrément : MR00030033ANRT2021
Date d'agrément : 16/09/2021

Mauritania

AGREE PAR L'ANEMAURITANIE
Numéro d'agrément : 0985/ARE/2021
Date d'agrément : 24/08/2021

Paraguay



Mexico



2020-10-I-0753

Customer Information

Singapore

Complies with IMDA Standards

DA 00461

Taiwan



South Africa



Thailand

1. ***This telecommunication equipment conforms to NTC technical requirement.***
2. ***This radiocommunication equipment has the electromagnetic field strength in compliance with the Safety Standard for the Use of Radiocommunication Equipment on Human Health announced by the National Telecommunications Commission.***

United Arab Emirates (U.A.E.)

South Korea



TRA
REGISTERED NO: ER80144/20
DEALER NO: DA83047/19

Customer Information

United Kingdom



Vietnam



United States and Canada



WARNING: Changes or modifications not expressly approved by the party responsible for compliance could void the user's authority to operate the equipment. The term "IC:" before the radio certification number only signifies that Industry Canada technical specifications were met.

FCC ID: L2CF5TR

IC: 3432A-F5TR

This device complies with Part 15 of the FCC Rules and with Innovation, Science and Economic Development Canada's licence-exempt RSS(s). Operation is subject to the following two conditions:

1. This device may not cause harmful interference, and
2. This device must accept any interference received, including interference that may cause undesired operation.

REMOTE FUNCTION ACTUATOR

China

CMIIT ID: 2018DJ4563

United States and Canada



WARNING: Changes or modifications not expressly approved by the party responsible for compliance could void the user's authority to operate the equipment. The term "IC:" before the radio certification number only signifies that Industry Canada technical specifications were met.

FCC ID: HYQS2NA0

IC: 1551A-S2NA0

This device complies with Part 15 of the FCC Rules and with Innovation, Science and Economic Development Canada's licence-exempt RSS(s). Operation is subject to the following two conditions:

1. This device may not cause harmful interference, and
2. This device must accept any interference received, including interference that may cause undesired operation.

Customer Information

CRUISE CONTROL MODULE

Argentina



Brazil



Djibouti

AGREE PAR LE MCPT (REPUBLIQUE DE DJIBOUTI)

Numéro d'agrément : 059/DDTIC/2020

Date d'agrément : 01/10/2020

EAC Marking - Russia, Belarus, Kazakhstan



Europe Union EU

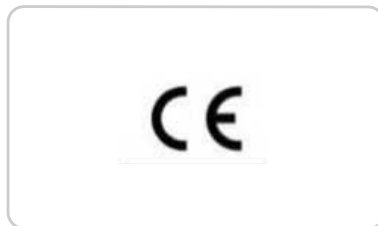

Ghana

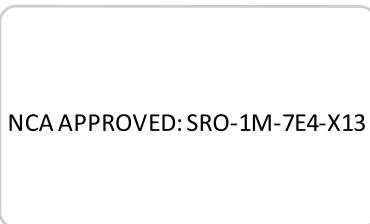

Customer Information

Independent State Of Samoa



Malaysia



HIDF16000009

Israel

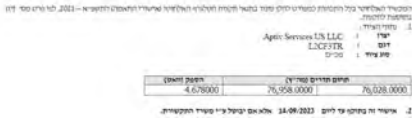

Mauritania

AGREE PAR L'ANE MAURITANIE
 Numéro d'agrément : 0835/ARE/2020
 Date d'agrément : 31/08/2020

Jamaica

This product has been Type Approved by Jamaica: SMA – F3TR.

Moldova



Customer Information

Morocco

AGREE PAR L'ANRT MAROC

Numéro d'agrément:
MR00030034ANRT2021

Date d'agrément: 16/09/2021

Pakistan



Paraguay



2020-10-I-0752

Sierra Leone



TAN: 2021-002-0028

Singapore

Complies with IMDA Standards

DA 00461

South Africa



Customer Information

South Korea



R-C-1Ap-F3TR

Taiwan

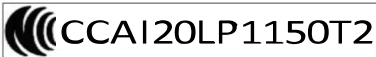

Thailand

1. ***This telecommunication equipment conforms to NTC technical requirement.***
2. ***This radiocommunication equipment has the electromagnetic field strength in compliance with the Safety Standard for the Use of Radiocommunication Equipment on Human Health announced by the National Telecommunications Commission.***

Ukraine



Unites Arab Emirates (U.A.E.)



United Kingdom



Customer Information

United States and Canada



WARNING: Changes or modifications not expressly approved by the party responsible for compliance could void the user's authority to operate the equipment. The term "IC:" before the radio certification number only signifies that Industry Canada technical specifications were met.

FCC ID: L2CF3TR

IC: 3432A-F3TR

This device complies with Part 15 of the FCC Rules and with Innovation, Science and Economic Development Canada's licence-exempt RSS(s). Operation is subject to the following two conditions:

1. This device may not cause harmful interference, and
2. This device must accept any interference received, including interference that may cause undesired operation.

Zambia



SYNC

Argentina

CNC COMISIÓN NACIONAL
DE COMUNICACIONES

CNC ID: C-24008

CNC COMISIÓN NACIONAL
DE COMUNICACIONES

CNC ID: C-24009

Brazil



08657-19-01505

Este equipamento não tem direito à proteção contra interferência prejudicial e não pode causar interferência em sistemas devidamente autorizados.

Customer Information



08658-19-01505

Este equipamento não tem direito à proteção
contra interferência prejudicial e não pode causar
interferência em sistemas devidamente autorizados.

European Union EU

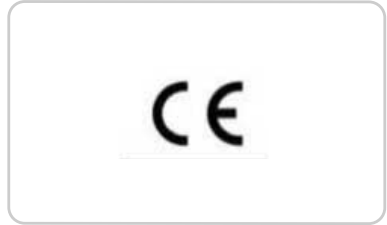

Djibouti

AGREE PAR LE MCPT (REPUBLIQUE DE DJIBOUTI)
Numéro d'agrément : 124/DDTIC/2019
Date d'agrément : 07/08/2019

Ghana

NCA APPROVED: ZRO-1H-7E3-182

NCA APPROVED: ZRO-1H-7E3-180

AGREE PAR LE MCPT (REPUBLIQUE DE DJIBOUTI)
Numéro d'agrément : 125/DDTIC/2019
Date d'agrément : 07/08/2019

Indonesia

Model: SYNC-G4
Sertifikat Nomor: 80700/SDPPI/2022
PLG ID: 13493



Customer Information

Model: SYNC-G4L
Sertifikat Nomor: **81116**/SDPPI/2022
PLG ID: 13493



Jamaica

This product has been Type Approved by
Jamaica: SMA – SYNC-G4.

This product has been Type Approved by Jamaica: SMA – SYNC-G4L.

Malaysia



SQASI/TA/19/4047

SQASI/TA/19/4046

Mauritania

AGREE PAR L'ANE MAURITANIE
Numéro d'agrément : 0692/ARE/2018
Date d'agrément : 08/08/2019

AGREE PAR L'ANE MAURITANIE
Numéro d'agrément : 0691/ARE/2018
Date d'agrément : 08/08/2019

Customer Information

Moldova



Pakistan



Morocco



Paraguay



AGREE PAR L'ANRT MAROC
N° D'AGRÉMENT: MR 20606 ANRT 2019
07 AOUT 2019

2020-03-I-00192

2020-03-I-00193

Serbia



Customer Information

Singapore

Complies with IMDA Standards

DA 00461

South Korea



MSIP-R-C-FDM-SYNG4



MSIP-R-C-FDM-SYNG4L

South Africa



Taiwan

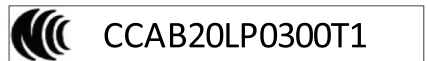

Customer Information

Ukraine



United Arab Emirates (U.A.E.)



TRA
REGISTERED No: ER74903/19
DEALER No: DA37380/15

United States and Canada



WARNING: Changes or modifications not expressly approved by the party responsible for compliance could void the user's authority to operate the equipment. The term "IC:" before the radio certification number only signifies that Industry Canada technical specifications were met.

FCC ID: KMH-SYNCG4

FCC ID: KMH-SYNCG4L

IC: 1422A-SYNCG4

IC: 1422A-SYNCG4L

This device complies with Part 15 of the FCC Rules and with Innovation, Science and Economic Development Canada's licence-exempt RSS(s). Operation is subject to the following two conditions:

1. This device may not cause harmful interference, and
2. This device must accept any interference received, including interference that may cause undesired operation.

Zambia



Customer Information

Europe Union EU

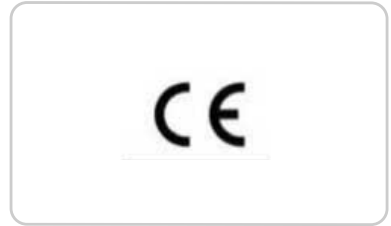

TELEMATICS CONTROL UNIT

Argentina



C-28150

Mexico



South Africa

Brazil



Customer Information

Taiwan

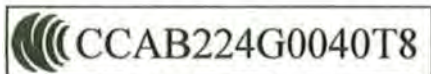

United Arab Emirates (U.A.E.)

TRA
REGISTERED No:
ER87741/20
DEALER No:
DA83047/19

United Kingdom



United States and Canada

 **WARNING:** Changes or modifications not expressly approved by the party responsible for compliance could void the user's authority to operate the equipment. The term "IC:" before the radio certification number only signifies that Industry Canada technical specifications were met.

FCC ID: KMH-14H074-NA1

IC: 1422A-14H074NA1

This device complies with Part 15 of the FCC Rules and with Innovation, Science and Economic Development Canada's licence-exempt RSS(s). Operation is subject to the following two conditions:

1. This device may not cause harmful interference, and
2. This device must accept any interference received, including interference that may cause undesired operation.

Vietnam



Customer Information

TIRE PRESSURE MONITORING SYSTEM SENSORS

Argentina



China

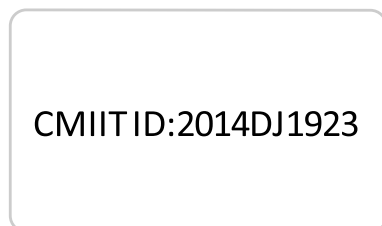

Democratic Republic of Congo

Agréé par l'ARPTC

N° d'homologation: HIR -0051/4/2014

Date d'homologation: 16/4/2014

Djibouti

AGREE PAR LE MCPT (REPUBLIQUE DE DJIBOUTI)

Numéro d'agrément : 198/MCPT/DDTCC

Date d'agrément : 7/9/2021

European Union (EU)



Customer Information

The RED 2014/53/EU (replacing R&TTE Directive 1999/5/EC on 13 June 2016) explicitly states that instructions for intentional radiators include reference to "(a) frequency band(s) in which the radio equipment operates; and (b) maximum radio-frequency power transmitted in the frequency band(s) in which the radio equipment operates," in addition to carrying over the general operational instruction and Declaration of Conformity inclusion requirements from the R&TTE Directive.

Hereby, Schrader Electronics Ltd. declares that the radio equipment type AG2SZ4 is in compliance with Directive 2014/53/EU. The full text of the EU declaration of conformity is available at the following internet address:

http://www.tpmseuroshop.com/documents/declaration_conformities

f=433.92MHz

P<10mW (e.i.r.p)

Schrader Electronics Ltd. 11 Technology Park, Belfast Road, Antrim BT41 1QS, Northern Ireland United Kingdom.

Ghana

Independent State of Samoa

NCA APPROVED: 3R88M14030

SMO
amoa

Customer Information

Nigeria

Connection and use of this communications equipment is permitted by the Nigerian Communications Commission

Pakistan



Oman

OMAN TRA
TA-R/1752/14
D090258

Russia



Paraguay



Sierra Leone



NR: 2017-06-I-0000175

TAN: 2017-002-0035

Customer Information

Serbia



South Korea



MSIP-CRM-SRD-AG2SZ4

Singapore

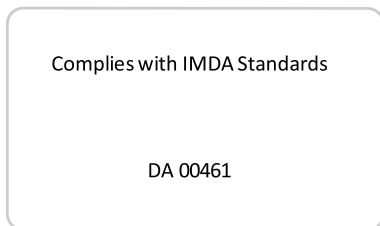

Taiwan

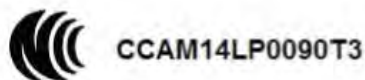

South Africa



TA-2014/064

Approved

Ukraine



Customer Information

United Arab Emirates

TRA REGISTERED No:

ER0130238/14

DEALER No:

DA0047074/10

United Kingdom

**UK
CA**

United States and Canada



WARNING: Changes or modifications not expressly approved by the party responsible for compliance could void the user's authority to operate the equipment. The term "IC:" before the radio certification number only signifies that Industry Canada technical specifications were met.

FCC ID: MRXAG2SZ4

IC: 2546A-AG2SZ4

This device complies with Part 15 of the FCC Rules and with Innovation, Science and Economic Development Canada's licence-exempt RSS(s). Operation is subject to the following two conditions:

1. This device may not cause harmful interference, and
2. This device must accept any interference received, including interference that may cause undesired operation.

Vietnam



Zambia



Customer Information

WIRELESS ACCESSORY CHARGING MODULE

Argentina



Brazil



Democratic Republic of Congo

Agréé par l'ARPTC
N° d'homologation : HER-0054/Juin/2021
Date d'homologation : 02/06/2021

European Union

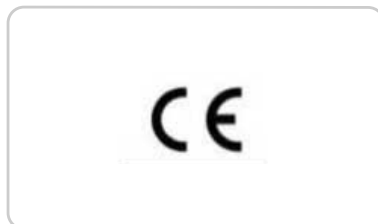

Customer Information

Ghana

Model: WCFDM00N2A5
Sertifikat Nomor: 80112/SDPPI/2022
PLG ID: 13493

NCA APPROVED: 7ES-7M-XB1-RDR



Indonesia

Model: WCFDM00N2A1
Sertifikat Nomor: 80110/SDPPI/2022
PLG ID: 13493



Model: WCFDM00N2A3
Sertifikat Nomor: 80111/SDPPI/2022
PLG ID: 13493



Israel

1. מספר אישור התאמה מטעם משרד התקשורת: 51-80014
2. חל אישור לבצע פעולות במכשיר שיש בהן כדי לשנות את תכונותיו האלחוטיות של המכשיר, ובכלל זה שינוי תכנה, החלפת אנטנה מקורית או הוספת אפשרות לחיבור לאנטנה חיצונית, בלא קבלת אישור משרד התקשורת, בשל החשש להפרעת אלחוטיות

1. מספר אישור התאמה מטעם משרד התקשורת: 51-80015
2. חל אישור לבצע פעולות במכשיר שיש בהן כדי לשנות את תכונותיו האלחוטיות של המכשיר, ובכלל זה שינוי תכנה, החלפת אנטנה מקורית או הוספת אפשרות לחיבור לאנטנה חיצונית, בלא קבלת אישור משרד התקשורת, בשל החשש להפרעת אלחוטיות

1. מספר אישור התאמה מטעם משרד התקשורת: 51-80013
2. חל אישור לבצע פעולות במכשיר שיש בהן כדי לשנות את תכונותיו האלחוטיות של המכשיר, ובכלל זה שינוי תכנה, החלפת אנטנה מקורית או הוספת אפשרות לחיבור לאנטנה חיצונית, בלא קבלת אישור משרד התקשורת, בשל החשש להפרעת אלחוטיות

Customer Information

Jamaica

This product has been Type Approved by Jamaica:
SMA - WCFDM00N2A.

AGREE PAR L'ANEMAURITANIE
Numéro d'agrément : 0934/ARE/2021
Date d'agrément : 23/03/2021

Malaysia



AGREE PAR L'ANEMAURITANIE
Numéro d'agrément : 0933/ARE/2021
Date d'agrément : 23/03/2021

RGEZ/35A/0521/S(21-2033)

RGEZ/35A/0521/S(21-2032)

RGEZ/35A/0521/S(21-2031)

Mauritania

AGREE PAR L'ANEMAURITANIE
Numéro d'agrément : 0935/ARE/2021
Date d'agrément : 23/03/2021

Moldova



Customer Information

Morocco

AGREE PAR L'ANRT MAROC
Nu méro d'agrément : MR 00027924ANRT 2021
Date d'agrément : 25/03/2021

AGREE PAR L'ANRT MAROC
Nu méro d'agrément : MR 00027925ANRT 2021
Date d'agrément : 25/03/2021

AGREE PAR L'ANRT MAROC
Nu méro d'agrément : MR 00027923ANRT 2021
Date d'agrément : 25/03/2021

Paraguay



2021-04-I-0204

2021-04-I-0203

2021-04-I-0202

Russia



Serbia



V005 21

Customer Information

Sierra Leone



TAN: 2021-002-0099

Singapore

Complies with IMDA Standards

DA 00461

South Korea



R-R-LGE-WCFDM00N2A1

Taiwan

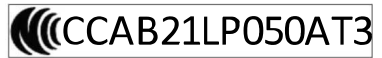

South Africa

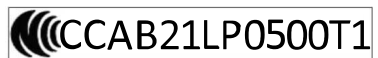

Customer Information

 CCAB21LP050BT5

品名 (Product name): 無線充電座

型號 (Type Designation): WCFDM00N2A1, WCFDM00N2A3, WCFDM00N2A5 產地 (Origin): 馬來西亞

額定電壓 (Input rating): 12V

製造日期 (Approval date): 2021.04.21



申請廠商名稱 (Approval name): 福特六和汽車股份有限公司

申請廠商地址 (Approval address): 桃園市中壢區中華路一段705號

Ukraine



United Kingdom



United Arab Emirates (U.A.E.)

TRA REGISTERED No:

ER98638/21

DEALER No:

DA37380/15

Customer Information

TRA REGISTERED No:

ER00421/21

DEALER No:

DA37380/15

TRA REGISTERED No:

ER00422/21

DEALER No:

DA37380/15

United States and Canada

FCC ID: BEJWCFDM00N2A

IC: 2703H-WCFDM00N2A

This equipment generates, uses, and can radiate radio frequency energy and may cause harmful interference to radio communications. There is no guarantee that interference will not occur in a particular installation. If this equipment does cause harmful interference to radio or television reception, please consult the dealer.

This product is not end-user serviceable.

RF Radiation Exposure Statement: This equipment complies with FCC RF Radiation exposure limits set forth for an uncontrolled environment. This device and its antenna must not be co-located or operating in conjunction with any other antenna or transmitter. This equipment should be installed and operated with a minimum distance of 20cm between the radiator and your body.

This device complies with Part 15 of the FCC Rules and with Innovation, Science and Economic Development Canada's licence-exempt RSS(s). Operation is subject to the following two conditions:

1. This device may not cause harmful interference, and
2. This device must accept any interference received, including interference that may cause undesired operation.

Le présent appareil est conforme aux CNR d'Industrie Canada applicables aux appareils radio exempts de licence. L'exploitation est autorisée aux deux conditions suivantes:

1. *L'appareil ne doit pas produire de brouillage;*
2. *L'appareil doit accepter tout brouillage radioélectrique subi, même si le brouillage est susceptible d'en compromettre le fonctionnement.*

Customer Information

Zambia



REPLACEMENT PARTS RECOMMENDATION

We have built your vehicle to the highest standards using quality parts. We recommend that you demand the use of genuine Ford and Motorcraft parts whenever your vehicle requires scheduled maintenance or repair. You can clearly identify genuine Ford and Motorcraft parts by looking for the Ford, FoMoCo or Motorcraft branding on the parts or their packaging.

Scheduled Maintenance and Mechanical Repairs

One of the best ways for you to make sure that your vehicle provides years of service is to have it maintained in line with our recommendations using parts that conform to the specifications detailed in this Owner's Manual.

Genuine Ford and Motorcraft parts meet or exceed these specifications.

Collision Repairs

We hope that you never experience a collision, but accidents happen sometimes.

Genuine Ford replacement collision parts meet our stringent requirements for fit, finish, structural integrity, corrosion protection and dent resistance. During vehicle development we validate that these parts deliver the intended level of protection as a whole system. A great way to know for sure you are getting this level of protection is to use genuine Ford replacement collision parts.

Warranty on Replacement Parts

Genuine Ford and Motorcraft replacement parts are the only replacement parts that benefit from a Ford Warranty.

The Ford Warranty may not cover damage caused to your vehicle as a result of failed non-Ford parts.

For additional information, refer to the terms and conditions of the Ford Warranty.

MOBILE COMMUNICATIONS EQUIPMENT



WARNING: Driving while distracted can result in loss of vehicle control, crash and injury. We strongly recommend that you use extreme caution when using any device that may take your focus off the road. Your primary responsibility is the safe operation of your vehicle. We recommend against the use of any hand-held device while driving and encourage the use of voice-operated systems when possible. Make sure you are aware of all applicable local laws that may affect the use of electronic devices while driving.

Customer Information

Using mobile communications equipment is becoming increasingly important in the conduct of business and personal affairs. However, you must not compromise your own or others' safety when using such equipment. Mobile communications can enhance personal safety and security when appropriately used, particularly in

emergency situations. Safety must be paramount when using mobile communications equipment to avoid negating these benefits. Mobile communication equipment includes, but is not limited to, cellular phones, pagers, portable email devices, text messaging devices and portable two-way radios.

ECALL USER INFORMATION

eCall User Information According to Regulation (EU) 2017/78, Annex I, Part 3

1 DESCRIPTION OF THE ECALL IN-VEHICLE SYSTEM

- 1.1. Overview of the 112-based eCall in-vehicle system, its operation and functionalities: See **What is eCall** (page 57).
- 1.2. The 112-based eCall service is a public service of general interest and is accessible free of charge.
- 1.3. The 112-based eCall in-vehicle system is activated by default. It is activated automatically by means of in-vehicle sensors in the event of a severe accident. It will also be triggered automatically when the vehicle is equipped with a TPS system which does not function in the event of a severe accident.
- 1.4. The 112-based eCall in-vehicle system can also be triggered manually, if needed. Instructions for manual activation of the system: See **Manually Making an Emergency Call** (page 57).
- 1.5. In the event of a critical system failure that would disable the 112-based eCall in-vehicle system, the following warning will be given to the occupants of the vehicle: See **Emergency Call Indicators** (page 58).

Customer Information

2 INFORMATION ON DATA PROCESSING

- 2.1. Any processing of personal data through the 112-based eCall in-vehicle system shall comply with the personal data protection rules provided for in Directives 95/46/EC (1) and 2002/58/EC (2) of the European Parliament and of the Council, and in particular, shall be based on the necessity to protect the vital interests of the individuals in accordance with Article 7(d) of Directive 95/46/EC (3).
- 2.2. Processing of such data is strictly limited to the purpose of handling the emergency eCall to the single European emergency number 112.
- 2.3. Types of data and its recipients.
- 2.3.1. The 112-based eCall in-vehicle system may collect and process only the following data:
 - Vehicle Identification Number.
 - Vehicle type (passenger vehicle or light commercial vehicle).
 - Vehicle propulsion storage type (gasoline/diesel/CNG/LPG/electric/hydrogen).
 - Vehicle last three locations and direction of travel.
 - Log file of the automatic activation of the system and its timestamp.
 - Any additional data (if applicable): -
- 2.3.2. Recipients of data processed by the 112-based eCall in-vehicle system are the relevant public safety answering points designated by the respective public authorities of the country on which territory they are located, to first receive and handle eCalls to the single European emergency number 112.
Additional information (if available): -
- 2.4. Arrangements for data processing.
- 2.4.1. The 112-based eCall in-vehicle system is designed in such a way as to ensure that the data contained in the system memory is not available outside the system before an eCall is triggered.
Additional remarks (if any): -
- 2.4.2. The 112-based eCall in-vehicle system is designed in such a way as to ensure that it is not traceable and not subject to any constant tracking in its normal operation status.
Additional remarks (if any): -
- 2.4.3. The 112-based eCall in-vehicle system is designed in such a way as to ensure that data in the system internal memory is automatically and continuously removed.

Customer Information

- 2.4.3.1. The vehicle location data is constantly overwritten in the internal memory of the system so as always to keep maximum of the last three up-to-date locations of the vehicle necessary for the normal functioning of the system.
- 2.4.3.2. The log of activity data in the 112-based eCall in-vehicle system is kept for no longer than necessary for attaining the purpose of handling the emergency eCall and in any case not beyond 13 hours from the moment an emergency eCall was initiated.
Additional remarks (if any): -
- 2.5. Modalities for exercising data subject's rights.
- 2.5.1. The data subject (the vehicle's owner) has a right of access to data and as appropriate to request the rectification, erasure or blocking of data, concerning him or her, the processing of which does not comply with the provisions of Directive 95/46/EC. Any third parties to whom the data have been disclosed have to be notified of such rectification, erasure or blocking carried out in compliance with this Directive, unless it proves impossible or involves a disproportionate effort.
- 2.5.2. The data subject has a right to complain to the competent data protection authority if he or she considers that his or her rights have been infringed as a result of the processing of his or her personal data.
- 2.5.3. Contact service responsible for handling access requests (if any): Contact the data protection officer of your local Public Safety Answering Point.
- (1) Directive 95/46/EC of the European Parliament and of the Council of 24 October 1995 on the protection of individuals with regard to the processing of personal data and on the free movement of such data (OJ L 281, 23.11.1995, p. 31).
- (2) Directive 2002/58/EC of the European Parliament and of the Council of 12 July 2002 concerning the processing of personal data and the protection of privacy in the electronic communications sector (Directive on privacy and electronic communications) (OJ L 201, 31.7.2002, p. 37).
- (3) Directive 95/46/EC is repealed by Regulation (EU) 2016/679 of the European Parliament and of the Council of 27 April 2016 on the protection of natural persons with regard to the processing of personal data and on the free movement of such data (General Data Protection Regulation) (OJ L 119, 4.5.2016, p. 1). The Regulation applies from 25 May 2018.

Customer Information

3 INFORMATION ON THIRD PARTY SERVICES AND OTHER ADDED VALUE SERVICES (IF FITTED)

- 3.1. Description of the operation and the functionalities of the TPS system/added value service: Your vehicle may be equipped with a modem that allows for emergency calls (eCall), automatic software updates and other services. See the information in this Owner's Manual or in the FordPass app for a description of these services. We provide a 112-based eCall in-vehicle system and we do not provide a TPS eCall system.
- 3.2. Any processing of personal data through the TPS system/other added value service shall comply with the personal data protection rules provided for in Directives 95/46/EC and 2002/58/EC.
- 3.2.1. Legal basis for the use of TPS system and/or added value services and for processing data through them: For information on the legal bases for processing of personal data through added value services, review the data privacy information for any services to which you subscribe. This privacy information can be found in the FordPass app or on the local Ford website.
- 3.3. The TPS system and/or other added value services shall process personal data only on the base of the explicit consent of the data subject (the vehicle's owner or owners).
- 3.4. Modalities for data processing through TPS system and/or other added value services, including any necessary additional information regarding traceability, tracking and processing of personal data: See the privacy information in the FordPass app or on the local Ford website.
- 3.5. The owner of a vehicle equipped with a TPS eCall system and/or other added value service in addition to the 112-based eCall in-vehicle system has the right to choose to use the 112-based eCall in-vehicle system rather than the TPS eCall system and the other added value service.
- 3.5.1. Contact details for handling TPS eCall system deactivation requests: You can have all added value services deactivated except for eCall. To find out more about having all added value services deactivated except for eCall, search Ask Ford on the local Ford website or contact the Ford Customer Relationship Center by e-mail through the FordPass app or by using the e-mail address on the local Ford website.

Customer Information

END USER LICENSE AGREEMENT

VEHICLE SOFTWARE END USER LICENSE AGREEMENT (EULA)

- You ("You" or "Your" as applicable) have acquired a vehicle having several devices, including SYNC ® and various control modules, ("DEVICES") that include software licensed or owned by Ford Motor Company and its affiliates ("FORD MOTOR COMPANY"). Those software products of FORD MOTOR COMPANY origin, as well as associated media, printed materials, and "online" or electronic documentation ("SOFTWARE") are protected by international intellectual property laws and treaties. The SOFTWARE is licensed, not sold. All rights reserved.
- The SOFTWARE may interface with and/or communicate with, or may be later upgraded to interface with and/or communicate with additional software and/or systems provided by FORD MOTOR COMPANY.

IF YOU DO NOT AGREE TO THIS END USER LICENSE AGREEMENT ("EULA") DO NOT USE THE DEVICES OR COPY THE SOFTWARE. ANY USE OF THE SOFTWARE, INCLUDING BUT NOT LIMITED TO USE ON THE DEVICES, WILL CONSTITUTE YOUR AGREEMENT TO THIS EULA (OR RATIFICATION OF ANY PREVIOUS CONSENT).

GRANT OF SOFTWARE LICENSE: This EULA grants you the following license:

- You may use the SOFTWARE as installed on the DEVICES and as otherwise interfacing with systems and/or services provide by or through FORD MOTOR COMPANY or its third party software and service providers.

Description of Other Rights and Limitations.

- **Speech Recognition:** If the SOFTWARE includes speech recognition component(s), you should understand that speech recognition is an inherently statistical process and that recognition errors are inherent in the process. Neither FORD MOTOR COMPANY nor its suppliers shall be liable for any damages arising out of errors in the speech recognition process. It is your responsibility to monitor any speech recognition functions included in the system.
- **Limitations on Reverse Engineering, Decompilation and Disassembly:** You may not reverse engineer, decompile, translate, disassemble or attempt to discover any source code or underlying ideas or algorithms of the SOFTWARE nor permit others to reverse engineer, decompile or disassemble the SOFTWARE, except and only to the extent that such activity is expressly permitted by applicable law notwithstanding this limitation or to the extent as may be permitted by the licensing terms governing use of any open source components included with the SOFTWARE.
- **Limitations on Distributing, Copying, Modifying and Creating Derivative Works:** You may not distribute, copy, make modifications to or create derivative works based on the SOFTWARE, except and only to the extent that such activity is expressly permitted by applicable law notwithstanding this limitation or to the extent as may be permitted by the licensing terms governing use of any open source components included with the SOFTWARE.

Customer Information

- **Single EULA:** The end user documentation for the DEVICES and related systems and services may contain multiple EULAs, such as multiple translations and/or multiple media versions (e.g., in the user documentation and in the software). Even if you receive multiple EULAs, you are licensed to use only one (1) copy of the SOFTWARE.
- **SOFTWARE Transfer:** You may permanently transfer your rights under this EULA only as part of a sale or transfer of the DEVICES, provided you retain no copies, you transfer all of the SOFTWARE (including all component parts, the media and printed materials, any upgrades, and, if applicable, the Certificate(s) of Authenticity), and the recipient agrees to the terms of this EULA. If the SOFTWARE is an upgrade, any transfer must include all prior versions of the SOFTWARE.
- **Termination:** Without prejudice to any other rights, FORD MOTOR COMPANY may terminate this EULA if you fail to comply with the terms and conditions of this EULA.
- **Internet-Based Services Components:** The SOFTWARE may contain components that enable and facilitate the use of certain Internet-based services. You acknowledge and agree that FORD MOTOR COMPANY, third party software and service suppliers, its affiliates and/or its designated agent may automatically check the version of the SOFTWARE and/or its components that you are utilizing and may provide upgrades or supplements to the SOFTWARE that may be automatically downloaded to your DEVICES.
- **Additional Software/Services:** The SOFTWARE may permit FORD MOTOR COMPANY, third party software and service suppliers, its affiliates and/or its designated agent to provide or make available to you SOFTWARE updates, supplements, add-on components, or Internet-based services components of the SOFTWARE after the date you obtain your initial copy of the SOFTWARE ("Supplemental Components".) SOFTWARE updates may cause you to incur additional charges from your wireless service provider. If FORD MOTOR COMPANY or third party software and services suppliers provide or make available to you Supplemental Components and no other EULA terms are provided along with the Supplemental Components, then the terms of this EULA shall apply. FORD MOTOR COMPANY, its affiliates and/or its designated agent reserve the right to discontinue without liability any Internet-based services provided to you or made available to you through the use of the SOFTWARE.

Customer Information

- **Links to Third Party Sites:** The SOFTWARE may provide you with the ability to link to third party sites. The third party sites are not under the control of FORD MOTOR COMPANY, its affiliates and/or its designated agent. Neither FORD MOTOR COMPANY nor its affiliates nor its designated agent are responsible for (i) the contents of any third party sites, any links contained in third party sites, or any changes or updates to third party sites, or (ii) webcasting or any other form of transmission received from any third party sites. If the SOFTWARE provides links to third party sites, those links are provided to you only as a convenience, and the inclusion of any link does not imply an endorsement of the third party site by FORD MOTOR COMPANY, its affiliates and/or its designated agent.
- **Obligation to Drive Responsibly:** You recognize your obligation to drive responsibly and keep attention on the road. You will read and abide with the DEVICES operating instructions particularly as they pertain to safety and you agree to assume any risk associated with the use of the DEVICES.

UPGRADES AND RECOVERY MEDIA:

If the SOFTWARE is provided by FORD MOTOR COMPANY separate from the DEVICES on media such as a ROM chip, CD ROM disk(s) or via web download or other means, and is labeled "For Upgrade Purposes Only" or "For Recovery Purposes Only" you may install one (1) copy of such SOFTWARE onto the DEVICES as a replacement copy for the existing SOFTWARE, and use it in accordance with this EULA, including any additional EULA terms accompanying the upgrade SOFTWARE.

INTELLECTUAL PROPERTY RIGHTS:

All title and intellectual property rights in and to the SOFTWARE (including but not limited to any images, photographs, animations, video, audio, music, text and "applets" incorporated into the SOFTWARE), the accompanying printed materials, and any copies of the SOFTWARE, are owned by FORD MOTOR COMPANY, or its affiliates or suppliers. The SOFTWARE is licensed, not sold. You may not copy the printed materials accompanying the SOFTWARE. All title and intellectual property rights in and to the content which may be accessed through use of the SOFTWARE is the property of the respective content owner and may be protected by applicable copyright or other intellectual property laws and treaties. This EULA grants you no rights to use such content outside its intended use. All rights not specifically granted under this EULA are reserved by FORD MOTOR COMPANY, its affiliates, and third party software and service providers and suppliers. Use of any on-line services which may be accessed through the SOFTWARE may be governed by the respective terms of use relating to such services. If this SOFTWARE contains documentation that is provided only in electronic form, you may print one copy of such electronic documentation.

EXPORT RESTRICTIONS: You acknowledge that the SOFTWARE is subject to U.S. and European Union export jurisdiction. You agree to comply with all applicable international and national laws that apply to the SOFTWARE, including the U.S. Export Administration Regulations, as well as end-user, end-use and destination restrictions issued by U.S. and other governments.

Customer Information

TRADEMARKS: This EULA does not grant you any rights in connection with any trademarks or service marks of FORD MOTOR COMPANY, its affiliates, and third party software and service providers.

PRODUCT SUPPORT: Please refer to FORD MOTOR COMPANY instructions provided in the documentation for the DEVICES product support, such as the vehicle owner guide.

Should you have any questions concerning this EULA, or if you desire to contact FORD MOTOR COMPANY for any other reason, please refer to the address provided in the documentation for the DEVICES.

No Liability for Certain Damages: EXCEPT AS PROHIBITED BY LAW, FORD MOTOR COMPANY, ANY THIRD PARTY SOFTWARE OR SERVICES SUPPLIERS, AND THEIR AFFILIATES SHALL HAVE NO LIABILITY FOR ANY INDIRECT, SPECIAL, CONSEQUENTIAL OR INCIDENTAL DAMAGES ARISING FROM OR IN CONNECTION WITH THE USE OR PERFORMANCE OF THE SOFTWARE. THIS LIMITATION SHALL APPLY EVEN IF ANY REMEDY FAILS OF ITS ESSENTIAL PURPOSE. THERE ARE NO WARRANTIES OTHER THAN THOSE THAT MAY BE EXPRESSLY PROVIDED FOR YOUR NEW VEHICLE.

SYNC® Automotive Important Safety Information Read and follow instructions:

- Before using your SYNC® system, read and follow all instructions and safety information provided in this end user manual ("Owner Guide".) Not following precautions found in the Owner Guide can lead to an accident or other serious injuries.

General Operation

- **Voice Command Control:** Certain functions within the SYNC® system may be accomplished using voice commands. Using voice commands while driving helps you to operate the system without removing your hands from the wheel or eyes from the road.
- **Prolonged Views of Screen:** Do not access any function requiring a prolonged view of the screen while you are driving. Pull over in a safe and legal manner before attempting to access a function of the system requiring prolonged attention.
- **Volume Setting:** Do not raise the volume excessively. Keep the volume at a level where you can still hear outside traffic and emergency signals while driving. Driving while unable to hear these sounds could cause an accident.
- **Navigation Features:** Any navigation features included in the system are intended to provide turn by turn instructions to get you to a desired destination. Please make certain all persons using this system carefully read and follow instructions and safety information fully.
- **Distraction Hazard:** Any navigation features may require manual (non-verbal) setup. Attempting to perform such set-up or insert data while driving can distract your attention and could cause an accident or other serious injury. Stop the vehicle in a safe and legal manner before attempting these operations.
- **Let Your Judgment Prevail:** Any navigation features are provided only as an aid. Make your driving decisions based on your observations of local conditions and existing traffic regulations. Any such feature is not a

Customer Information

substitute for your personal judgment. Any route suggestions made by this system should never replace any local traffic regulations or your personal judgment or knowledge of safe driving practices.

- **Route Safety:** Do not follow the route suggestions if doing so would result in an unsafe or illegal maneuver, if you would be placed in an unsafe situation, or if you would be directed into an area that you consider unsafe. The driver is ultimately responsible for the safe operation of the vehicle and therefore, must evaluate whether it is safe to follow the suggested directions.
- **Potential Map Inaccuracy:** Maps used by this system may be inaccurate because of changes in roads, traffic controls or driving conditions. Always use good judgment and common sense when following the suggested routes.
- **Emergency Services:** Do not rely on any navigation features included in the system to route you to emergency services. Ask local authorities or an emergency services operator for these locations. Not all emergency services such as police, fire stations, hospitals and clinics are likely to be contained in the map database for such navigation features.

Your Responsibilities and Assumptions of Risk

- You agree to each of the following:(a) Any use of the SOFTWARE while driving an automobile or other vehicle in violation of applicable law or otherwise driving in an unsafe manner presents a significant risk of distracted driving and should not be attempted under any circumstances;(b) Use of the SOFTWARE at excessive volume poses a significant risk of hearing damage and should not be attempted under any circumstances;(c) The SOFTWARE may not be compatible with new or different versions of an operating system, third party software, or third party services, and the SOFTWARE may potentially cause a critical failure of an operating system, third party software, or third party service.(d) Any third party service accessed by or third party software used with the SOFTWARE (i) may charge an additional fee for access, (ii) may not work correctly, on an uninterrupted basis, or error free, (iii) may change streaming formats or discontinue operation, (iv) may contain adult, profane or offensive content; and (v) may contain inaccurate, false or misleading traffic, weather, financial or safety information or other content; and (e) Use of the SOFTWARE may cause you to incur additional charges from your wireless service provider (WSP) and any data or minute calculators that may be included in the software program are for reference only, are not warranted in any way and should not be relied upon in anyway.
- When using the SOFTWARE, you agree to be responsible for and assume the entire risk to the items set forth in Section (a) – (e) above.

Customer Information

Disclaimer of Warranty

YOU EXPRESSLY ACKNOWLEDGE AND AGREE THAT USE OF THE DEVICES AND SOFTWARE IS AT YOUR SOLE RISK AND THAT THE ENTIRE RISK AS TO SATISFACTORY QUALITY, PERFORMANCE, COMPATIBILITY, ACCURACY AND EFFORT IS WITH YOU. TO THE MAXIMUM EXTENT PERMITTED BY APPLICABLE LAW, THE SOFTWARE AND ANY THIRD PARTY SOFTWARE OR THIRD-PARTY SERVICES ARE PROVIDED "AS IS" AND "AS AVAILABLE", WITH ALL FAULTS AND WITHOUT WARRANTY OF ANY KIND, AND FORD MOTOR COMPANY HEREBY DISCLAIMS ALL WARRANTIES AND CONDITIONS WITH RESPECT TO THE SOFTWARE, THIRD PARTY SOFTWARE, AND THIRD-PARTY SERVICES, EITHER EXPRESS, IMPLIED OR STATUTORY, INCLUDING, BUT NOT LIMITED TO, THE IMPLIED WARRANTIES AND/OR CONDITIONS OF MERCHANTABILITY, OF SATISFACTORY QUALITY, OF FITNESS FOR AN PARTICULAR PURPOSE, OF ACCURACY, OF QUIET ENJOYMENT, AND NON-INFRINGEMENT OF THIRD-PARTY RIGHTS. FORD MOTOR COMPANY DOES NOT WARRANT (a) AGAINST INTERFERENCE WITH YOUR ENJOYMENT OF THE SOFTWARE, THIRD PARTY SOFTWARE, OR THIRD-PARTY SERVICES, (b) THAT THE SOFTWARE, THIRD PARTY SOFTWARE, OR THIRD-PARTY SERVICES WILL MEET YOUR REQUIREMENTS, (c) THAT THE OPERATION OF THE SOFTWARE, THIRD PARTY SOFTWARE, OR THIRD-PARTY SERVICES WILL BE UNINTERRUPTED OR ERROR-FREE, (d) OR THAT DEFECTS IN THE SOFTWARE, THIRD PARTY SOFTWARE, OR THIRD-PARTY SERVICES WILL BE CORRECTED. NO ORAL OR WRITTEN INFORMATION OR ADVICE GIVEN BY FORD MOTOR COMPANY OR ITS AUTHORIZED REPRESENTATIVE SHALL

CREATE A WARRANTY. SHOULD THE SOFTWARE, THIRD PARTY SOFTWARE, OR THIRD-PARTY SERVICES PROVE DEFECTIVE, YOU ASSUME THE ENTIRE COST OF ALL NECESSARY SERVICING, REPAIR OR CORRECTION. SOME JURISDICTIONS DO NOT ALLOW THE DISCLAIMER OF IMPLIED WARRANTIES OR LIMITATIONS ON APPLICABLE STATUTORY RIGHTS OF A CONSUMER, SO THE ABOVE DISCLAIMER MAY NOT FULLY APPLY TO YOU. THE SOLE WARRANTY PROVIDED BY FORD MOTOR COMPANY SHALL BE FOUND IN THE WARRANTY INFORMATION INCLUDING WITH YOUR OWNER GUIDE. TO THE EXTENT THAT THERE IS ANY CONFLICT BETWEEN THE TERMS OF THIS SECTION AND THE WARRANTY BOOKLET, THE WARRANTY BOOKLET SHALL CONTROL.

Applicable Law, Venue, Jurisdiction

- The laws of the State of Michigan govern this EULA and Your use of the SOFTWARE. Your use of the SOFTWARE may also be subject to other local, state, national, or international laws. Any litigation arising out of or related to this EULA shall be brought and maintained exclusively in a court of the State of Michigan located in Wayne County or in the United States District Court for the Eastern District of Michigan. You hereby consent to submit to the personal jurisdiction of a court in the State of Michigan located in Wayne County and the United States District Court for the Eastern District of Michigan for any dispute arising out of or relating to this EULA.

Customer Information

Binding Arbitration and Class Action Waiver

(a) Application. This Section applies to any dispute EXCEPT IT DOES NOT INCLUDE A DISPUTE RELATING TO COPYRIGHT INFRINGEMENT, OR TO THE ENFORCEMENT OR VALIDITY OF YOUR, FORD MOTOR COMPANY, OR ANY OF FORD MOTOR COMPANY'S LICENSORS' INTELLECTUAL PROPERTY RIGHTS.

Dispute means any dispute, action, or other controversy between You and FORD MOTOR COMPANY, other than the exceptions listed above, concerning the SOFTWARE (including its price) or this EULA, whether in contract, warranty, tort, statute, regulation, ordinance, or any other legal or equitable basis.

(b) Notice of Dispute. In the event of a Dispute, You or FORD MOTOR COMPANY must give the other a "Notice of Dispute", which is a written statement of the name, address, and contact information of the party giving it, the facts giving rise to the dispute, and the relief requested. You and FORD MOTOR COMPANY will attempt to resolve any dispute through informal negotiation within 60 days from the date the Notice of Dispute is sent. After 60 days, You or FORD MOTOR COMPANY may commence arbitration.

(c) Small claims court. You may also litigate any dispute in small claims court in your county of residence or FORD MOTOR COMPANY'S principal place of business, if the dispute meets all requirements to be heard in the small claims court. You may litigate in small claims court whether or not You negotiated informally first.

(d) Binding arbitration. If You and FORD MOTOR COMPANY, do not resolve any dispute by informal negotiation or in small claims court, any other effort to resolve the dispute will be conducted exclusively by binding arbitration. You are giving up

the right to litigate (or participate in as a party or class member) all disputes in court before a judge or jury. Instead, all disputes will be resolved before a neutral arbitrator, whose decision will be final except for a limited right of appeal under the Federal Arbitration Act. Any court with jurisdiction over the parties may enforce the arbitrator's award.

(e) Class action waiver. Any proceedings to resolve or litigate any dispute in any forum will be conducted solely on an individual basis. Neither you nor FORD MOTOR COMPANY, will seek to have any dispute heard as a class action, as a private attorney general action, or in any other proceeding in which any party acts or proposes to act in a representative capacity. No arbitration or proceeding will be combined with another without the prior written consent of all parties to all affected arbitrations or proceedings.

(f) Arbitration procedure. Any arbitration will be conducted by the American Arbitration Association (the "AAA"), under its Commercial Arbitration Rules. If You are an individual and use the SOFTWARE for personal or vehicle use, or if the value of the dispute is \$75,000 or less whether or not You are an individual or how You use the SOFTWARE, the AAA Supplementary Procedures for Consumer-Related Disputes will also apply. To commence arbitration, submit a Commercial Arbitration Rules Demand for Arbitration form to the AAA. You may request a telephonic or in-person hearing by following the AAA rules. In a dispute involving \$10,000 or less, any hearing will be telephonic unless the arbitrator finds good cause to hold an in-person hearing instead. For more information, see adr.org or call 1-800-778-7879. You agree to commence arbitration only in your county of residence or FORD MOTOR COMPANY'S principal place of business. The arbitrator

Customer Information

may award the same damages to you individually as a court could. The arbitrator may award declaratory or injunctive relief only to you individually, and only to the extent required to satisfy your individual claim.

(g) Arbitration fees and incentives.

- i. Disputes involving \$75,000 or less. FORD MOTOR COMPANY will promptly reimburse your filing fees and pay the AAA's and arbitrator's fees and expenses. If you reject FORD MOTOR COMPANY'S last written settlement offer made before the arbitrator was appointed ("last written offer"), your dispute goes all the way to an arbitrator's decision (called an "award"), and the arbitrator awards you more than the last written offer, FORD MOTOR COMPANY will give you three incentives: (1) pay the greater of the award or \$1,000; (2) pay twice your reasonable attorney's fees, if any; and (3) reimburse any expenses (including expert witness fees and costs) that your attorney reasonably accrues for investigating, preparing, and pursuing your claim in arbitration. The arbitrator will determine the amounts.
- ii. Disputes involving more than \$75,000. The AAA rules will govern payment of filing fees and the AAA's and arbitrator's fees and expenses.
- iii. Disputes involving any amount. In any arbitration you commence, FORD MOTOR COMPANY will seek its AAA or arbitrator's fees and expenses, or Your filing fees it reimbursed, only if the arbitrator finds the arbitration frivolous or brought for an improper purpose. In any arbitration FORD MOTOR COMPANY commences, it will pay all

filing, AAA, and arbitrator's fees and expenses. It will not seek its attorney's fees or expenses from you in any arbitration. Fees and expenses are not counted in determining how much a dispute involves.

(h) Claims or disputes must be filed within one year. To the extent permitted by law, any claim or dispute under this EULA to which this Section applies must be filed within one year in small claims court (Section c) or in arbitration (Section d). The one-year period begins when the claim or dispute first could be filed. If such a claim or dispute is not filed within one year, it is permanently barred.

(i) Severability. If the class action waiver (Section e) is found to be illegal or unenforceable as to all or some parts of a dispute, then that portion of Section e will not apply to those parts. Instead, those parts will be severed and proceed in a court of law, with the remaining parts proceeding in arbitration. If any other provision of that portion Section e is found to be illegal or unenforceable, that provision will be severed with the remainder of Section e remaining in full force and effect.

Telenav Software End User License Agreement

Please read these terms and conditions carefully before you use the TeleNav Software. Your use of the TeleNav Software indicates that you accept these terms and conditions. If you do not accept these terms and conditions, do not break the seal of the package, launch, or otherwise use the TeleNav Software. TeleNav may revise this Agreement and the privacy policy at any time, with or without notice to you. You agree to visit <http://www.telenav.com> from time to time to review the then current version of this Agreement and of the privacy policy.

Customer Information

1. Safe and Lawful Use

You acknowledge that devoting attention to the TeleNav Software may pose a risk of injury or death to you and others in situations that otherwise require your undivided attention, and you therefore agree to comply with the following when using the TeleNav Software:

- (a) observe all traffic laws and otherwise drive safely;
- (b) use your own personal judgment while driving. If you feel that a route suggested by the TeleNav Software instructs you to perform an unsafe or illegal maneuver, places you in an unsafe situation, or directs you into an area that you consider to be unsafe, do not follow such instructions;
- (c) do not input destinations, or otherwise manipulate the TeleNav Software, unless your vehicle is stationary and parked;
- (d) do not use the TeleNav Software for any illegal, unauthorized, unintended, unsafe, hazardous, or unlawful purposes, or in any manner inconsistent with this Agreement;
- (e) arrange all GPS and wireless devices and cables necessary for use of the TeleNav Software in a secure manner in your vehicle so that they will not interfere with your driving and will not prevent the operation of any safety device (such as an airbag).

You agree to indemnify and hold TeleNav harmless against all claims resulting from any dangerous or otherwise inappropriate use of the TeleNav Software in any moving vehicle, including as a result of your failure to comply with the directions above.

2. Account Information

You agree: (a) when registering the TeleNav Software, to provide TeleNav with true, accurate, current, and complete information about yourself, and (b) to inform TeleNav promptly of any changes to such information, and to keep it true, accurate, current and complete.

3. Software License

- Subject to your compliance with the terms of this Agreement, TeleNav hereby grants to you a personal, non-exclusive, non-transferable license (except as expressly permitted below in connection with your permanent transfer of the TeleNav Software license), without the right to sublicense, to use the TeleNav Software (in object code form only) in order to access and use the TeleNav Software. This license shall terminate upon any termination or expiration of this Agreement. You agree that you will use the TeleNav Software only for your personal business or leisure purposes, and not to provide commercial navigation services to other parties.

3.1 License Limitations

- **(a)** reverse engineer, decompile, disassemble, translate, modify, alter or otherwise change the TeleNav Software or any part thereof; **(b)** attempt to derive the source code, audio library or structure of the TeleNav Software without the prior express written consent of TeleNav; **(c)** remove from the TeleNav Software, or alter, any of TeleNav's or its suppliers' trademarks, trade names, logos, patent or copyright notices, or other notices or markings; **(d)**

Customer Information

distribute, sublicense or otherwise transfer the TeleNav Software to others, except as part of your permanent transfer of the TeleNav Software; or **(e)** use the TeleNav Software in any manner that

- i. infringes the intellectual property or proprietary rights, rights of publicity or privacy or other rights of any party,
- ii. violates any law, statute, ordinance or regulation, including but not limited to laws and regulations related to spamming, privacy, consumer and child protection, obscenity or defamation, or
- iii. is harmful, threatening, abusive, harassing, tortuous, defamatory, vulgar, obscene, libelous, or otherwise objectionable; and (f) lease, rent out, or otherwise permit unauthorized access by third parties to the TeleNav Software without advanced written permission of TeleNav.

4. Disclaimers

- To the fullest extent permissible pursuant to applicable law, in no event will TeleNav, its licensors and suppliers, or agents or employees of any of the foregoing, be liable for any decision made or action taken by you or anyone else in reliance on the information provided by the TeleNav Software. TeleNav also does not warrant the accuracy of the map or other data used for the TeleNav Software. Such data may not always reflect reality due to, among other things, road closures, construction, weather, new roads and other changing conditions. You are responsible for the entire risk arising out of your use of the TeleNav Software. For example but without limitation, you agree not to rely on the TeleNav Software for critical navigation in areas where the well-being or survival of you or others

is dependent on the accuracy of navigation, as the maps or functionality of the TeleNav Software are not intended to support such high risk applications, especially in more remote geographical areas.

- TELENAV EXPRESSLY DISCLAIMS AND EXCLUDES ALL WARRANTIES IN CONNECTION WITH THE TELENAV SOFTWARE, WHETHER STATUTORY, EXPRESS OR IMPLIED, INCLUDING ALL WARRANTIES WHICH MAY ARISE FROM COURSE OF DEALING, CUSTOM OR TRADE AND INCLUDING, BUT NOT LIMITED TO, THE IMPLIED WARRANTIES OF MERCHANTABILITY, FITNESS FOR A PARTICULAR PURPOSE AND NON-INFRINGEMENT OF THIRD PARTY RIGHTS WITH RESPECT TO THE TELENAV SOFTWARE.
- Certain jurisdictions do not permit the disclaimer of certain warranties, so this limitation may not apply to you.

5. Limitation of Liability

- TO THE EXTENT PERMITTED UNDER APPLICABLE LAW, UNDER NO CIRCUMSTANCES SHALL TELENAV OR ITS LICENSORS AND SUPPLIERS BE LIABLE TO YOU OR TO ANY THIRD PARTY FOR ANY INDIRECT, INCIDENTAL, CONSEQUENTIAL, SPECIAL OR EXEMPLARY DAMAGES (INCLUDING IN EACH CASE, BUT NOT LIMITED TO, DAMAGES FOR THE INABILITY TO USE THE EQUIPMENT OR ACCESS DATA, LOSS OF DATA, LOSS OF BUSINESS, LOSS OF PROFITS, BUSINESS INTERRUPTION OR THE LIKE) ARISING OUT OF THE USE OF OR INABILITY TO USE THE TELENAV SOFTWARE, EVEN IF TELENAV HAS BEEN ADVISED OF THE POSSIBILITY OF SUCH DAMAGES. NOTWITHSTANDING ANY DAMAGES THAT YOU MIGHT INCUR FOR ANY

Customer Information

REASON WHATSOEVER (INCLUDING, WITHOUT LIMITATION, ALL DAMAGES REFERENCED HEREIN AND ALL DIRECT OR GENERAL DAMAGES IN CONTRACT, TORT (INCLUDING NEGLIGENCE) OR OTHERWISE), THE ENTIRE LIABILITY OF TELENAV AND OF ALL OF TELENAV'S SUPPLIERS SHALL BE LIMITED TO THE AMOUNT ACTUALLY PAID BY YOU FOR THE TELENAV SOFTWARE. SOME STATES AND/OR JURISDICTIONS DO NOT ALLOW THE EXCLUSION OR LIMITATION OF INCIDENTAL OR CONSEQUENTIAL DAMAGES, SO THE ABOVE LIMITATIONS OR EXCLUSIONS MAY NOT APPLY TO YOU.

6. Arbitration and Governing Law

- You agree that any dispute, claim or controversy arising out of or relating to this Agreement or the TeleNav Software shall be settled by independent arbitration involving a neutral arbitrator and administered by the American Arbitration Association in the County of Santa Clara, California. The arbitrator shall apply the Commercial Arbitration Rules of the American Arbitration Association, and the judgment upon the award rendered by the arbitrator may be entered by any court having jurisdiction. Note that there is no judge or jury in an arbitration proceeding and the decision of the arbitrator shall be binding upon both parties. You expressly agree to waive your right to a jury trial. This Agreement and performance hereunder will be governed by and construed in accordance with the laws of the State of California, without giving effect to its conflict of law provisions. To the extent judicial action is necessary in connection with the binding arbitration, both TeleNav and you agree to submit

to the exclusive jurisdiction of the courts of the County of Santa Clara, California. The United Nations Convention on Contracts for the International Sale of Goods shall not apply.

7. Assignment

- You may not resell, assign, or transfer this Agreement or any of your rights or obligations, except in totality, in connection with your permanent transfer of the TeleNav Software, and expressly conditioned upon the new user of the TeleNav Software agreeing to be bound by the terms and conditions of this Agreement. Any such sale, assignment or transfer that is not expressly permitted under this paragraph will result in immediate termination of this Agreement, without liability to TeleNav, in which case you and all other parties shall immediately cease all use of the TeleNav Software. Notwithstanding the foregoing, TeleNav may assign this Agreement to any other party at any time without notice, provided the assignee remains bound by this Agreement.

8. Miscellaneous

8.1

This Agreement constitutes the entire agreement between TeleNav and you with respect to the subject matter hereof.

8.2

Except for the limited licenses expressly granted in this Agreement, TeleNav retains all right, title and interest in and to the TeleNav Software, including without limitation all related intellectual property rights. No licenses or other rights which are not expressly granted in this Agreement are intended to, or shall be, granted or

Customer Information

conferred by implication, statute, inducement, estoppel or otherwise, and TeleNav and its suppliers and licensors hereby reserve all of their respective rights other than the licenses explicitly granted in this Agreement.

8.3

By using the TeleNav Software, you consent to receive from TeleNav all communications, including notices, agreements, legally required disclosures or other information in connection with the TeleNav Software (collectively, "Notices") electronically. TeleNav may provide such Notices by posting them on TeleNav's Website or by downloading such Notices to your wireless device. If you desire to withdraw your consent to receive Notices electronically, you must discontinue your use of the TeleNav Software.

8.4

TeleNav's or your failure to require performance of any provision shall not affect that party's right to require performance at any time thereafter, nor shall a waiver of any breach or default of this Agreement constitute a waiver of any subsequent breach or default or a waiver of the provision itself.

8.5

If any provision herein is held unenforceable, then such provision will be modified to reflect the intention of the parties, and the remaining provisions of this Agreement will remain in full force and effect.

8.6

The headings in this Agreement are for convenience of reference only, will not be deemed to be a part of this Agreement, and will not be referred to in connection with the construction or interpretation of this Agreement. As used in this Agreement, the words "include" and "including" and variations thereof, will not be deemed to be terms of limitation, but rather will be deemed to be followed by the words "without limitation".

9. Other Vendors Terms and Conditions

- The Telenav Software utilizes map and other data licensed to Telenav by third party vendors for the benefit of you and other end users. This Agreement includes end-user terms applicable to these companies (included at the end of this Agreement), and thus your use of the Telenav Software is also subject to such terms. You agree to comply with the following additional terms and conditions, which are applicable to Telenav's third party vendor licensors.

9.1 End User Terms Required by HERE North America, LLC

The data ("Data") is provided for your personal, internal use only and not for resale. It is protected by copyright, and is subject to the following terms and conditions which are agreed to by you, on the one hand, and Telenav ("Telenav") and its licensors (including their licensors and suppliers) on the other hand.

© 2013 HERE. All rights reserved.

The Data for areas of Canada includes information taken with permission from Canadian authorities, including: © Her Majesty the Queen in Right of Canada, © Queen's Printer for Ontario, © Canada Post Corporation, GeoBase®, © Department of Natural Resources Canada.

Customer Information

HERE holds a non-exclusive license from the United States Postal Service® to publish and sell ZIP+4® information.

©United States Postal Service® 2014. Prices are not established, controlled or approved by the United States Postal Service®. The following trademarks and registrations are owned by the USPS: United States Postal Service, USPS, and ZIP+4

The Data for Mexico includes certain data from Instituto Nacional de Estadística y Geografía.

9.2 End User Terms Required by NAV2 (Shanghai) Co., Ltd

The data (“Data”) is provided for your personal, internal use only and not for resale. It is protected by copyright, and is subject to the following terms and conditions which are agreed to by you, on the one hand, and NAV2 (Shanghai) Co., Ltd (“NAV2”) and its licensors (including their licensors and suppliers) on the other hand. 20xx. All rights reserved

Terms and Conditions

Permitted Use. You agree to use this Data together with the Telenav Software solely for the internal business and personal purposes for which you were licensed, and not for service bureau, time-sharing or other similar purposes. Accordingly, but subject to the restrictions set forth in the following paragraphs, you agree not to otherwise reproduce, copy, modify, decompile, disassemble, create any derivative works of, or reverse engineer any portion of this Data, and may not transfer or distribute it in any form, for any purpose, except to the extent permitted by mandatory laws.

Restrictions. Except where you have been specifically licensed to do so by Telenav, and without limiting the preceding paragraph, you may not use this Data (a) with any products, systems, or applications installed or otherwise connected to or in communication with vehicles, capable of vehicle navigation, positioning, dispatch, real time route guidance, fleet management or similar applications; or (b) with or in communication with any positioning devices or any mobile or wireless-connected electronic or computer devices, including without limitation cellular phones, palmtop and handheld computers, pagers, and personal digital assistants or PDAs.

Warning. The Data may contain inaccurate or incomplete information due to the passage of time, changing circumstances, sources used and the nature of collecting comprehensive geographic data, any of which may lead to incorrect results.

No Warranty. This Data is provided to you “as is,” and you agree to use it at your own risk. Telenav and its licensors (and their licensors and suppliers) make no guarantees, representations or warranties of any kind, express or implied, arising by law or otherwise, including but not limited to, content, quality, accuracy, completeness, effectiveness, reliability, fitness for a particular purpose, usefulness, use or results to be obtained from this Data, or that the Data or server will be uninterrupted or error-free.

Disclaimer of Warranty: TELENAV AND ITS LICENSORS (INCLUDING THEIR LICENSORS AND SUPPLIERS) DISCLAIM ANY WARRANTIES, EXPRESS OR IMPLIED, OF QUALITY, PERFORMANCE, MERCHANTABILITY, FITNESS FOR A

Customer Information

PARTICULAR PURPOSE OR NON-INFRINGEMENT. Some States, Territories and Countries do not allow certain warranty exclusions, so to that extent the above exclusion may not apply to you.

Disclaimer of Liability: TELENAV AND ITS LICENSORS (INCLUDING THEIR LICENSORS AND SUPPLIERS) SHALL NOT BE LIABLE TO YOU: IN RESPECT OF ANY CLAIM, DEMAND OR ACTION, IRRESPECTIVE OF THE NATURE OF THE CAUSE OF THE CLAIM, DEMAND OR ACTION ALLEGING ANY LOSS, INJURY OR DAMAGES, DIRECT OR INDIRECT, WHICH MAY RESULT FROM THE USE OR POSSESSION OF THE INFORMATION; OR FOR ANY LOSS OF PROFIT, REVENUE, CONTRACTS OR SAVINGS, OR ANY OTHER DIRECT, INDIRECT, INCIDENTAL, SPECIAL OR CONSEQUENTIAL DAMAGES ARISING OUT OF YOUR USE OF OR INABILITY TO USE THIS INFORMATION, ANY DEFECT IN THE INFORMATION, OR THE BREACH OF THESE TERMS OR CONDITIONS, WHETHER IN AN ACTION IN CONTRACT OR TORT OR BASED ON A WARRANTY, EVEN IF TELENAV OR ITS LICENSORS HAVE BEEN ADVISED OF THE POSSIBILITY OF SUCH DAMAGES. Some States, Territories and Countries do not allow certain liability exclusions or damages limitations, so to that extent the above may not apply to you.

Export Control. You shall not export from anywhere any part of the Data or any direct product thereof except in compliance with, and with all licenses and approvals required under, applicable export laws, rules and regulations, including but not limited to the laws, rules and regulations administered by the Office of Foreign Assets Control of the U.S. Department of Commerce and the Bureau of Industry and Security of the U.S. Department of Commerce. To the extent that any such

export laws, rules or regulations prohibit HERE from complying with any of its obligations hereunder to deliver or distribute Data, such failure shall be excused and shall not constitute a breach of this Agreement.

Entire Agreement. These terms and conditions constitute the entire agreement between Telenav (and its licensors, including their licensors and suppliers) and you pertaining to the subject matter hereof, and supersedes in their entirety any and all written or oral agreements previously existing between us with respect to such subject matter.

Governing Law. The above terms and conditions shall be governed by the laws of the State of Illinois [insert "Netherlands" where European HERE Data is used], without giving effect to (i) its conflict of laws provisions, or (ii) the United Nations Convention for Contracts for the International Sale of Goods, which is explicitly excluded. You agree to submit to the jurisdiction of the State of Illinois [insert "The Netherlands" where European HERE Data is used] for any and all disputes, claims and actions arising from or in connection with the Data provided to you hereunder.

Government End Users. If the Data is being acquired by or on behalf of the United States government or any other entity seeking or applying rights similar to those customarily claimed by the United States government, this Data is a "commercial item" as that term is defined at 48 C.F.R. ("FAR") 2.101, is licensed in accordance with these End-User Terms, and each copy of Data delivered or otherwise furnished shall be marked and embedded as appropriate with the following "Notice of Use," and shall be treated in accordance with such Notice:

Customer Information

NOTICE OF USE

CONTRACTOR (MANUFACTURER/
SUPPLIER) NAME: HERE

CONTRACTOR (MANUFACTURER/
SUPPLIER) ADDRESS: c/o Nokia, 425
West Randolph Street, Chicago, Illinois
60606

This Data is a commercial item as
defined in FAR 2.101 and is subject to
these End-User Terms under which this
Data was provided.

© 1987 – 2014 HERE – All rights reserved.

If the Contracting Officer, federal government agency, or any federal official refuses to use the legend provided herein, the Contracting Officer, federal government agency, or any federal official must notify HERE prior to seeking additional or alternative rights in the Data.

I. US/Canada Territory

A. United States Data. The End-User Terms for any Application containing Data for the United States shall contain the following notices:

“HERE holds a non-exclusive license from the United States Postal Service® to publish and sell ZIP+4® information.”

“©United States Postal Service® 20XX. Prices are not established, controlled or approved by the United States Postal Service®. The following trademarks and registrations are owned by the USPS: United States Postal Service, USPS, and ZIP+4.”

B. Canada Data. The following provisions apply to the Data for Canada, which may include or reflect data from third party licensors (“Third Party Data”), including Her Majesty the Queen in Right of Canada (“Her Majesty”), Canada Post Corporation (“Canada Post”) and the Department of Natural Resources of Canada (“NRCan”):

1. Disclaimer and Limitation: Client agrees that its use of the Third Party Data is subject to the following provisions:

a. Disclaimer: The Third Party Data is licensed on an “as is” basis. The licensors of such data, including Her Majesty, Canada Post and NRCan, make no guarantees, representations or warranties respecting such data, either express or implied, arising by law or otherwise, including but not limited to, effectiveness, completeness, accuracy or fitness for a particular purpose.

b. Limitation on Liability: The Third Party Data licensors, including Her Majesty, Canada Post and NRCan, shall not be liable: (i) in respect of any claim, demand or action, irrespective of the nature of the cause of the claim, demand or action alleging any loss, injury or damages, direct or indirect, which may result from the use or possession of such Data; or (ii) in any way for loss of revenues or contracts, or any other consequential loss of any kind resulting from any defect in the Data.

Customer Information

2. Copyright Notice: In connection with each copy of all or any portion of the Data for the Territory of Canada, Client shall affix in a conspicuous manner the following copyright notice on at least one of: (i) the label for the storage media of the copy; (ii) the packaging for the copy; or (iii) other materials packaged with the copy, such as user manuals or end user license agreements: "This data includes information taken with permission from Canadian authorities, including © Her Majesty the Queen in Right of Canada, © Queen's Printer for Ontario, © Canada Post Corporation, GeoBase®, © The Department of Natural Resources Canada. All rights reserved."

3. End-User Terms: Except as otherwise agreed by the parties, in connection with the provision of any portion of the Data for the Territory of Canada to End-Users as may be authorized under the Agreement, Client shall provide such End-Users, in a reasonably conspicuous manner, with terms (set forth with other end user terms required to be provided under the Agreement, or as otherwise may be provided, by Client) which shall include the following provisions on behalf of the Third Party Data licensors, including Her Majesty, Canada Post and NRCan:

The Data may include or reflect data of licensors, including Her Majesty the Queen in the Right of Canada ("Her Majesty"), Canada Post Corporation ("Canada Post") and the Department of Natural Resources Canada ("NRCan"). Such data is licensed on an "as is" basis. The licensors, including Her Majesty, Canada Post and NRCan, make no guarantees, representations or warranties respecting such data,

either express or implied, arising by law or otherwise, including but not limited to, effectiveness, completeness, accuracy or fitness for a particular purpose. The licensors, including Her Majesty, Canada Post and NRCan, shall not be liable in respect of any claim, demand or action, irrespective of the nature of the cause of the claim, demand or action alleging any loss, injury or damages, direct or indirect, which may result from the use or possession of the data or the Data. The licensors, including Her Majesty, Canada Post and NRCan, shall not be liable in any way for loss of revenues or contracts, or any other consequential loss of any kind resulting from any defect in the data or the Data.

End User shall indemnify and save harmless the licensors, including Her Majesty, Canada Post and NRCan, and their officers, employees and agents from and against any claim, demand or action, irrespective of the nature of the cause of the claim, demand or action, alleging loss, costs, expenses, damages or injuries (including injuries resulting in death) arising out of the use or possession of the data or the Data.

4. Additional Provisions: The terms contained in this Section are in addition to all of the rights and obligations of the parties under the Agreement. To the extent that any of the provisions of this Section are inconsistent with, or conflict with, any other provisions of the Agreement, the provisions of this Section shall prevail.

Customer Information

II. Mexico. The following provision applies to the Data for Mexico, which includes certain data from the Instituto Nacional de Estadística y Geografía (“INEGI”):

A. Any and all copies of the Data and/or packaging containing Data for Mexico shall contain the following notice: “Fuente: INEGI (Instituto Nacional de Estadística y Geografía)”

III. Latin America Territory

A. Third Party Notices. Any and all copies of the Data and/or packaging relating thereto shall include the respective Third Party Notices set forth below and used as described below corresponding to the Territory (or portion thereof) included in such copy:

Territory Notice

Argentina	IGN “INSTITUTO GEOGRAFICO NACIONAL ARGENTINO”
Ecuador	“INSTITUTO GEOGRAFICO MILITAR DEL ECUADOR AUTORIZACION N° IGM-2011-01- PCO-01 DEL 25 DE ENERO DE 2011” “source: © IGN 2009 - BD TOPO ®”
Guadeloupe, French Guiana and Martinique Mexico	“Fuente: INEGI (Instituto Nacional de Estadística y Geografía)”

IV. Middle East Territory

A. Third Party Notices. Any and all copies of the Data and/or packaging relating thereto shall include the respective Third Party Notices set forth below and used as described below corresponding to the Territory (or portion thereof) included in such copy:

Country Notice

Jordan “© Royal Jordanian Geographic Centre”. The foregoing notice requirement for Jordan Data is a material term of the Agreement. If Client or any of its permitted sublicensees (if any) fail to meet such requirement, HERE shall have the right to terminate Client’s license with respect to the Jordan Data.

B. Jordan Data. Client and its permitted sublicensees (if any) are restricted from licensing and/or otherwise distributing HERE’s database for the country of Jordan (“Jordan Data”) for use in Enterprise Applications to (i) non-Jordanian entities for use of the Jordan Data solely in Jordan or (ii) Jordan-based customers. In addition, Client, its permitted sublicensees (if any) and End-Users are restricted from using the Jordan Data in Enterprise Applications if such party is (i) a non-Jordanian entity using the Jordan Data solely in Jordan or (ii) a Jordan-based customer. For purposes of the foregoing, “Enterprise Applications” shall mean Geomarketing applications, GIS applications, mobile business asset management applications, call center applications, telematics applications, public organization Internet applications or for providing geocoding services.

Customer Information

V. Europe Territory

A. Use of Certain Traffic Codes in Europe

1. General Restrictions Applicable to Traffic Codes. Client acknowledges and agrees that in certain countries of the Europe Territory, Client will need to obtain rights directly from third party RDS-TMC code providers to receive and use the Traffic Codes in the Data and to deliver to End-Users Transactions in any way derived from or based on such Traffic Codes. For such countries, HERE shall deliver the Data incorporating Traffic Codes to Client only after receiving certification from Client of its having obtained such rights.

2. Display of Third Party Rights Legends for Belgium. Client shall, for each Transaction that uses Traffic Codes for Belgium, provide the following notice to the End-User: "Traffic Codes for Belgium are provided by the Ministerie van de Vlaamse Gemeenschap and the Ministère de l'Équipement et des Transports."

B. Paper Maps. With respect to any license granted to Client relating to making, selling or distributing paper maps (i.e., a map fixed on a paper or paper-like medium): (a) such license with respect to Data for the Territory of Great Britain is conditioned on Client's entering into and complying with a separate written agreement with the Ordnance Survey ("OS") to create and sell paper maps, Client's paying to the OS any and all applicable paper map royalties, and Client's complying with the OS copyright notice requirements; (b) such license for selling or otherwise distributing for charge with respect to Data for the Territory of Czech Republic

is conditioned on Client's obtaining prior written consent from Kartografie a.s.; (c) such license for selling or distributing with respect to Data for the Territory of Switzerland is conditioned on Client's obtaining a permit from Bundesamt für Landestopografie of Switzerland; (d) Client is restricted from using Data for the Territory of France to create paper maps with a scale between 1:5,000 and 1:250,000; and (e) Client is restricted from using any Data to create, sell or distribute paper maps that are the same or substantially similar, in terms of data content and specific use of color, symbols and scale, to paper maps published by the European national mapping agencies, including without limitation, Landvermessungämter of Germany, Topografische Dienst of the Netherlands, Nationaal Geografisch Instituut of Belgium, Bundesamt für Landestopografie of Switzerland, Bundesamt für Eich-und Vermessungswesen of Austria, and the National Land Survey of Sweden.

C. OS Enforcement. Without limiting Section IV(B) above, with respect to Data for the Territory of Great Britain, Client acknowledges and agrees that the Ordnance Survey ("OS") may bring a direct action against Client to enforce compliance with the OS copyright notice (see Section IV(D) below) and paper map requirements (see Section IV(B) above) contained in this Agreement.

D. Third Party Notices. Any and all copies of the Data and/or packaging relating thereto shall include the respective Third Party Notices set forth below and used as described below corresponding to the Territory (or portion thereof) included in such copy:

Country(ies) Notice

Customer Information

Austria	“© Bundesamt für Eich- und Vermessungswesen”	Spain	“Información geográfica propiedad del CNIG”
Croatia Cyprus, Estonia, Latvia, Lithuania, Moldova, Poland, Slovenia and/or Ukraine	“© EuroGeographics”	Sweden	“Based upon electronic data © National Land Survey Sweden.”
France	“source: © IGN 2009 – BD TOPO ®”	Switzerland	“Topografische Grundlage: © Bundesamt für Landestopographie.
Germany	“Die Grundlagendaten wurden mit Genehmigung der zuständigen Behörden entnommen”	E. Respective Country Distribution. Client acknowledges that HERE has not received approvals to distribute map data for the following countries in such respective countries: Albania, Belarus, Kyrgyzstan, Moldova and Uzbekistan. HERE may update such list from time to time. The license rights granted to Client under this TL with respect to the Data for such countries are contingent upon Client’s compliance with all applicable laws and regulations, including, without limitation, any required licenses or approvals to distribute the Application incorporating such Data in such respective countries.	
Great Britain	“Contains Ordnance Survey data © Crown copyright and database right 2010 Contains Royal Mail data © Royal Mail copyright and database right 2010”	VI. Australia Territory	A. Third Party Notices. Any and all copies of the Data and/or packaging relating thereto shall include the respective Third Party Notices set forth below and used as described below corresponding to the Territory (or portion thereof) included in such copy: Copyright. Based on data provided under license from PSMA Australia Limited (www.pasma.com.au).
Greece	“Copyright Geomatics Ltd.”		
Hungary	“Copyright © 2003; Top-Map Ltd.”		
Italy	“La Banca Dati Italiana è stata prodotta usando quale riferimento anche cartografia numerica ed al tratto prodotta e fornita dalla Regione Toscana.”		
Norway	“Copyright © 2000; Norwegian Mapping Authority”		
Portugal	“Source: IgeoE – Portugal”		

Customer Information

Product incorporates data which is © 20XX Telstra Corporation Limited, GM Holden Limited, Intelomatics Australia Pty Ltd and Continental Pty Ltd.

B. Third Party Notices for Australia. In addition to the foregoing, the End-User Terms for any Application containing RDS-TMC Traffic Codes for Australia shall contain the following notice: “Product incorporates traffic location codes which is © 20XX Telstra Corporation Limited and its licensors.”

AT&T Vehicle Network Carrier Telematics Disclosure

END USER FOR PURPOSES OF THIS SECTION MEANS YOU AND YOUR HEIRS, EXECUTORS, LEGAL PERSONAL REPRESENTATIVES AND PERMITTED ASSIGNS. FOR PURPOSES OF THIS SECTION “UNDERLYING WIRELESS SERVICE CARRIER” INCLUDES ITS AFFILIATES AND CONTRACTORS AND THEIR RESPECTIVE OFFICERS, DIRECTORS, EMPLOYEES, SUCCESSORS AND ASSIGNS. END USER HAS NO CONTRACTUAL RELATIONSHIP WITH THE UNDERLYING WIRELESS SERVICE CARRIER AND END USER IS NOT A THIRD PARTY BENEFICIARY OF ANY AGREEMENT BETWEEN FORD AND UNDERLYING CARRIER. END USER UNDERSTANDS AND AGREES THAT THE UNDERLYING CARRIER HAS NO LEGAL, EQUITABLE, OR OTHER LIABILITY OF ANY KIND TO END USER. IN ANY EVENT, REGARDLESS OF THE FORM OF THE ACTION, WHETHER FOR BREACH OF CONTRACT, WARRANTY, NEGLIGENCE, STRICT LIABILITY IN TORT OR OTHERWISE, END USER’S EXCLUSIVE REMEDY FOR CLAIMS ARISING IN ANY WAY IN CONNECTION WITH THIS AGREEMENT, FOR ANY CAUSE WHATSOEVER, INCLUDING BUT NOT LIMITED TO ANY FAILURE OR

DISRUPTION OF SERVICE PROVIDED HEREUNDER, IS LIMITED TO PAYMENT OF DAMAGES IN AN AMOUNT NOT TO EXCEED THE AMOUNT PAID BY END USER FOR THE SERVICES DURING THE TWO-MONTH PERIOD PRECEDING THE DATE THE CLAIM AROSE.

(ii) END USER AGREES TO INDEMNIFY AND HOLD HARMLESS THE UNDERLYING WIRELESS SERVICE CARRIER AND ITS OFFICERS, EMPLOYEES, AND AGENTS AGAINST ANY AND ALL CLAIMS, INCLUDING WITHOUT LIMITATION CLAIMS FOR LIBEL, SLANDER, OR ANY PROPERTY DAMAGE, PERSONAL INJURY OR DEATH, ARISING IN ANY WAY, DIRECTLY OR INDIRECTLY, IN CONNECTION WITH THIS AGREEMENT OR THE USE, FAILURE TO USE, OR INABILITY TO USE THE DEVICE EXCEPT WHERE THE CLAIMS RESULT FROM THE UNDERLYING CARRIER’S GROSS NEGLIGENCE OR WILLFUL MISCONDUCT. THIS INDEMNITY WILL SURVIVE THE TERMINATION OF THE AGREEMENT.

(iii) END USER HAS NO PROPERTY RIGHT IN ANY NUMBER ASSIGNED TO THE DEVICE.

(iv) END USER UNDERSTANDS THAT FORD AND THE UNDERLYING CARRIER CANNOT GUARANTY THE SECURITY OF WIRELESS TRANSMISSIONS, AND WILL NOT BE LIABLE FOR ANY LACK OF SECURITY RELATING TO THE USE OF THE SERVICES

THE SERVICE IS FOR [END USER’S] USE ONLY AND END USER MAY NOT RESELL THE SERVICE TO ANY OTHER PARTY END USER UNDERSTANDS THAT THE UNDERLYING CARRIER DOES NOT GUARANTEE ANY END USER UNINTERRUPTED SERVICE OR COVERAGE. THE UNDERLYING CARRIER DOES NOT WARRANT THAT END USERS CAN OR WILL BE LOCATED USING THE SERVICE. THE UNDERLYING CARRIER

Customer Information

MAKES NO WARRANTY, EXPRESS OR IMPLIED, OF MERCHANTABILITY OR FITNESS FOR A PARTICULAR PURPOSE, SUITABILITY, OR PERFORMANCE REGARDING ANY SERVICES OR GOODS, AND IN NO EVENT SHALL AT&T BE LIABLE, WHETHER OR NOT DUE TO ITS OWN NEGLIGENCE, FOR ANY: (A) ACT OR OMISSION OF A THIRD PARTY; (B) MISTAKES, OMISSIONS, INTERRUPTIONS, ERRORS, FAILURES TO TRANSMIT, DELAYS, OR DEFECTS IN THE SERVICE PROVIDED BY OR THROUGH THE UNDERLYING CARRIER; (C) DAMAGE OR INJURY CAUSED BY SUSPENSION OR TERMINATION BY THE UNDERLYING CARRIER; OR (D) DAMAGE OR INJURY CAUSED BY A FAILURE OR DELAY IN CONNECTING A CALL TO ANY ENTITY, INCLUDING 911 OR ANY OTHER EMERGENCY SERVICE. TO THE FULL EXTENT ALLOWED BY LAW, THE END USER RELEASES, INDEMNIFIES AND HOLDS THE UNDERLYING CARRIER HARMLESS FROM AND AGAINST ANY AND ALL CLAIMS OF ANY PERSON OR ENTITY FOR DAMAGES OF ANY NATURE ARISING IN ANY WAY FROM OR RELATING TO, DIRECTLY OR INDIRECTLY, SERVICES PROVIDED BY THE UNDERLYING CARRIER OR ANY PERSON'S USE THEREOF, INCLUDING CLAIMS ARISING IN WHOLE OR IN PART FROM THE ALLEGED NEGLIGENCE OF THE UNDERLYING CARRIER.

VII. China Territory

Personal Use Only

You agree to use this Data together with [insert name of Client Application] for the solely personal, non-commercial purposes for which you were licensed, and not for service bureau, time-sharing or other similar purposes. Accordingly, but subject to the restrictions set forth in the following paragraphs, you may copy this Data only as necessary for your personal use to (i)

view it, and (ii) save it, provided that you do not remove any copyright notices that appear and do not modify the Data in any way. You agree not to otherwise reproduce, copy, modify, decompile, disassemble or reverse engineer any portion of this Data, and may not transfer or distribute it in any form, for any purpose, except to the extent permitted by mandatory laws.

Restrictions

Except where you have been specifically licensed to do so by NAV2, and without limiting the preceding paragraph, you may not (a) use this Data with any products, systems, or applications installed or otherwise connected to or in communication with vehicles, capable of vehicle navigation, positioning, dispatch, real time route guidance, fleet management or similar applications; or (b) with or in communication with any positioning devices or any mobile or wireless-connected electronic or computer devices, including without limitation cellular phones, palmtop and handheld computers, pagers, and personal digital assistants or PDAs. You agree to cease using this Data if you fail to comply with these terms and conditions.

Limited Warranty

NAV2 warrants that (a) the Data will perform substantially in accordance with the accompanying written materials for a period of ninety (90) days from the date of receipt, and (b) any support services provided by NAV2 shall be substantially as described in applicable written materials provided to you by NAV2, and NAV2's support engineers will make commercially reasonable efforts to solve any problem issues.

Customer Information

Customer Remedies

NAV2 and its suppliers' entire liability and your exclusive remedy shall be, at NAV2's sole discretion, either (a) return of the price paid, if any, or (b) repair or replacement of the Data that do not meet NAV2's Limited Warranty and that are returned to NAV2 with a copy of your receipt. This Limited Warranty is void if failure of the Data has resulted from accident, abuse, or misapplication. Any replacement Data will be warranted for the remainder of the original warranty period or thirty (30) days, whichever is longer. Neither these remedies nor any product support services offered by NAV2 are available without proof of purchase from an authorized international source.

No Other Warranty:

EXCEPT FOR THE LIMITED WARRANTY SET FORTH ABOVE AND TO THE EXTENT PERMITTED BY APPLICABLE LAW, NAV2 AND ITS LICENSORS (INCLUDING THEIR LICENSORS AND SUPPLIERS) DISCLAIM ANY WARRANTIES, EXPRESS OR IMPLIED, OF QUALITY, PERFORMANCE, MERCHANTABILITY, FITNESS FOR A PARTICULAR PURPOSE, OWNERSHIP OR NON-INFRINGEMENT. Certain warranty exclusions may not be permitted under applicable law, so to that extent the above exclusion may not apply to you.

Limited Liability:

TO THE EXTENT PERMITTED BY APPLICABLE LAW, NAV2 AND ITS LICENSORS (INCLUDING THEIR LICENSORS AND SUPPLIERS) SHALL NOT BE LIABLE TO YOU: IN RESPECT OF ANY CLAIM, DEMAND OR ACTION, IRRESPECTIVE OF THE NATURE OF THE CAUSE OF THE CLAIM, DEMAND OR ACTION ALLEGING ANY LOSS, INJURY OR DAMAGES, DIRECT OR INDIRECT, WHICH MAY RESULT FROM THE USE OR POSSESSION OF THE INFORMATION; OR

FOR ANY LOSS OF PROFIT, REVENUE, CONTRACTS OR SAVINGS, OR ANY OTHER DIRECT, INDIRECT, INCIDENTAL, SPECIAL OR CONSEQUENTIAL DAMAGES ARISING OUT OF YOUR USE OF OR INABILITY TO USE THIS INFORMATION, ANY DEFECT IN THE INFORMATION, OR THE BREACH OF THESE TERMS OR CONDITIONS, WHETHER IN AN ACTION IN CONTRACT OR TORT OR BASED ON A WARRANTY, EVEN IF NAV2 OR ITS LICENSORS HAVE BEEN ADVISED OF THE POSSIBILITY OF SUCH DAMAGES. UNDER NO CIRCUMSTANCES SHALL NAV2'S OR ITS SUPPLIERS' LIABILITY HEREUNDER EXCEED THE PRICE PAID. Certain liability exclusions may not be permitted under applicable law, so to that extent the above exclusion may not apply to you.

Export Control

You agree not to export to anywhere any part of the Data provided to you or any direct product thereof except in compliance with, and with all licenses and approvals required under, applicable export laws, rules and regulations.

IP Protection

The Data are owned by NAV2 or its suppliers and are protected by applicable copyright and other intellectual property law and treaties. The Data are provided solely on the basis of a license to use, not sale.

Entire Agreement

These terms and conditions constitute the entire agreement between NAV2 (and its licensors, including their licensors and suppliers) and you pertaining to the subject matter hereof, and supersedes in their entirety any and all written or oral agreements previously existing between us with respect to such subject matter.

Customer Information

Governing Law.

The above terms and conditions shall be governed by the laws of the People's Republic of China, without giving effect to (i) its conflict of laws provisions, or (ii) the United Nations Convention for Contracts for the International Sale of Goods, which is explicitly excluded. Any dispute arising from or in connection with the Data provided to you hereunder shall be submitted to the Shanghai International Economic and Trade Arbitration Commission for arbitration.

Gracenote® Copyright

CD and music-related data from Gracenote, Inc., copyright©

2000-2007 Gracenote. Gracenote Software, copyright © 2000-2007 Gracenote. This product and service may practice one or more of the following U.S. Patents 5,987,525; 6,061,680; 6,154,773; 6,161,132; 6,230,192; 6,230,207; 6,240,459; 6,330,593 and other patents issued or pending. Some services supplied under license from Open Globe, Inc. for U.S. Patent 6,304,523.

Gracenote and CDDB are registered trademarks of Gracenote. The Gracenote logo and logotype, and the "Powered by Gracenote™" logo are trademarks of Gracenote.

Gracenote® End User License Agreement (EULA)

This device contains software from Gracenote, Inc. of 2000 Powell Street Emeryville, California 94608 ("Gracenote").

The software from Gracenote (the "Gracenote Software") enables this device to do disc and music file identification and obtain music-related information, including name, artist, track, and title information ("Gracenote Data") from online servers

("Gracenote Servers"), and to perform other functions. You may use Gracenote Data only by means of the intended End User functions of this device. This device may contain content belonging to Gracenote's providers. If so, all of the restrictions set forth herein with respect to Gracenote Data shall also apply to such content and such content providers shall be entitled to all of the benefits and protections set forth herein that are available to Gracenote. You agree that you will use the content from Gracenote ("Gracenote Content"), Gracenote Data, the Gracenote Software, and Gracenote Servers for your own personal, non-commercial use only. You agree not to assign, copy, transfer or transmit the Gracenote Content, Gracenote Software or any Gracenote Data (except in a Tag associated with a music file) to any third party. YOU AGREE NOT TO USE OR EXPLOIT GRACENOTE CONTENT, GRACENOTE DATA, THE GRACENOTE SOFTWARE, OR GRACENOTE SERVERS, EXCEPT AS EXPRESSLY PERMITTED HEREIN.

You agree that your non-exclusive licenses to use the Gracenote Content, Gracenote Data, the Gracenote Software, and Gracenote Servers will terminate if you violate these restrictions. If your licenses terminate, you agree to cease any and all use of the Gracenote Content, Gracenote Data, the Gracenote Software, and Gracenote Servers.

Gracenote, respectively, reserve all rights in Gracenote Data, the Gracenote Software, and the Gracenote Servers and Gracenote Content, including all ownership rights. Under no circumstances will either Gracenote become liable for any payment to you for any information that you provide,

Customer Information

including any copyrighted material or music file information. You agree that Gracenote may enforce its respective rights, collectively or separately, under this agreement against you, directly in each company's own name.

Gracenote uses a unique identifier to track queries for statistical purposes. The purpose of a randomly assigned numeric identifier is to allow Gracenote to count queries without knowing anything about who you are. For more information, see the web page at www.gracenote.com for the Gracenote Privacy Policy.

THE GRACENOTE SOFTWARE, EACH ITEM OF GRACENOTE DATA AND THE GRACENOTE CONTENT ARE LICENSED TO YOU "AS IS". NEITHER GRACENOTE MAKES ANY REPRESENTATIONS OR WARRANTIES, EXPRESS OR IMPLIED, REGARDING THE ACCURACY OF ANY GRACENOTE DATA FROM THE GRACENOTE SERVERS OR GRACENOTE CONTENT. GRACENOTE COLLECTIVELY AND SEPARATELY RESERVE THE RIGHT TO DELETE DATA AND/OR CONTENT FROM THE COMPANIES' RESPECTIVE SERVERS OR, IN THE CASE OF GRACENOTE, CHANGE DATA CATEGORIES FOR ANY CAUSE THAT GRACENOTE DEEMS SUFFICIENT. NO WARRANTY IS MADE THAT EITHER GRACENOTE CONTENT OR THE GRACENOTE SOFTWARE OR GRACENOTE SERVERS ARE ERROR-FREE OR THAT THE FUNCTIONING OF THE GRACENOTE SOFTWARE OR GRACENOTE SERVERS WILL BE UNINTERRUPTED. GRACENOTE IS NOT OBLIGATED TO PROVIDE YOU WITH ANY ENHANCED OR ADDITIONAL DATA TYPES THAT GRACENOTE MAY CHOOSE TO PROVIDE IN THE FUTURE AND IS FREE TO DISCONTINUE ITS ONLINE SERVICES AT ANY TIME. GRACENOTE DISCLAIMS ALL WARRANTIES EXPRESS OR IMPLIED, INCLUDING, BUT NOT LIMITED TO,

IMPLIED WARRANTIES OF MERCHANTABILITY, FITNESS FOR A PARTICULAR PURPOSE, TITLE, AND NON-INFRINGEMENT. NEITHER GRACENOTE WARRANTS THE RESULTS THAT WILL BE OBTAINED BY YOUR USE OF THE GRACENOTE SOFTWARE OR ANY GRACENOTE SERVER. IN NO CASE WILL GRACENOTE BE LIABLE FOR ANY CONSEQUENTIAL OR INCIDENTAL DAMAGES OR FOR ANY LOST PROFITS OR LOST REVENUES FOR ANY REASON WHATSOEVER. © Gracenote 2007.

Taiwan Territory

According to the "Technical Specifications for Low Power Radio Frequency Equipment" formulated by the National Communications and Communication Committee of the Executive Yuan: 3.8.2. For the low-power radio frequency equipment that has obtained the verification certificate, the company, firm or user shall not change the frequency, increase the power or change the characteristics and functions of the original design without authorization.

The use of low-power radio frequency equipment must not affect flight safety and interfere with legal communications: when the system detects interference, immediately stop using it until there is no interference.

The aforementioned legal communication refers to the wireless communication operated in accordance with the provisions of the Telecommunications Management Law. Low-power radio frequency equipment needs to endure the interference of legal communication or industrial, scientific and medical radio wave radiation electrical equipment.

Customer Information

SUNA TRAFFIC CHANNEL – TERMS AND CONDITIONS

By activating, using and/or accessing the SUNA Traffic Channel, SUNA Predictive or other content or material provided by Intelematics (together, **SUNA Products and/or Services**), you must accept certain terms and conditions. The following is a brief summary of the terms and conditions that apply to you. To view the full terms and conditions relevant to your use of the SUNA Products and/or Services, please consult:

Website
www.sunattraffic.com.au/termsandconditions/

1. Acceptance

By using SUNA Products and/or Services, you will be deemed to have accepted and agreed to be bound by the terms and conditions fully detailed at:

Website
www.sunattraffic.com.au/termsandconditions/

2. Intellectual Property

SUNA Products and/or Services are for your personal use. You may not record, or retransmit the content, nor use the content in association with any other traffic information or route guidance service or device not approved by Intelematics. You obtain no right of ownership in any Intellectual Property Rights (including copyright) in the data that is used to provide SUNA Products and/or Services.

3. Appropriate Use

SUNA Products and/or Services are intended as an aid to personal motoring and travel planning, and do not provide comprehensive or accurate information on all occasions. On occasions, you may experience additional delay as a result of using SUNA Products and/or Services. You acknowledge that it is not intended, or suitable, for use in applications where time of arrival or driving directions may impact the safety of the public or yourself.

4. Use of SUNA Products and Services while driving

You, and other authorized drivers of the vehicle in which SUNA Products and/or Services are available or installed and active, remain at all times responsible for observing all relevant laws and codes of safe driving. In particular, you agree to only actively operate SUNA Products and/or Services when the Vehicle is at a complete stop and it is safe to do so.

5. Service Continuity and Reception of the SUNA Traffic Channel

We will use reasonable endeavors to provide the SUNA Traffic Channel 24 hours a day, 365 days a year. The SUNA Traffic Channel may occasionally be unavailable for technical reasons or for planned maintenance. We will try to perform maintenance at times when congestion is light. We reserve the right to withdraw SUNA Products and/or Services at any time.

Also, we cannot assure the uninterrupted reception of the SUNA Traffic Channel RDS-TMC signal at any particular location.

6. Limitation of Liability

Neither Intelematics (nor its suppliers or the manufacturer of your device (the **"Suppliers"**)) shall be liable to you or to any third party for any damages either direct, indirect, incidental, consequential or otherwise arising out of the use of or inability to use SUNA Products and/or

Customer Information

Services even if Intelematics or a Supplier has been advised of the possibility of such damages. You also acknowledge that neither Intelematics nor any Supplier guarantees nor make any warranties that relate to the availability, accuracy or completeness of SUNA Products and/or Services, and to the extent which it is lawful to do so, both Intelematics and each Supplier excludes any warranties which might otherwise be implied by any State or Federal legislation in relation to SUNA Products and/or Services.

7. Please Note

Great care has been taken in preparing this manual. Constant product development may mean that some information is not entirely up-to-date. The information in this document is subject to change without notice.

Appendices

ELECTROMAGNETIC COMPATIBILITY



WARNING: Do not place objects or mount equipment on or near the airbag cover, on the side of the front or rear seatbacks, or in areas that may come into contact with a deploying airbag. Failure to follow these instructions may increase the risk of personal injury in the event of a crash.



WARNING: Do not fasten antenna cables to vehicle wiring, fuel pipes and brake pipes.



WARNING: Keep antenna and power cables at least 10 cm (4 in) from any electronic modules and airbags.

Note: We test and certify your vehicle to meet electromagnetic compatibility legislation. It is your responsibility to make sure that any equipment an authorized dealer installs on your vehicle complies with applicable local legislation and other requirements. Installation of some aftermarket electronic devices could degrade the performance of vehicle functions, which use radio frequency signals such as broadcast radio receiver, tire pressure monitoring system, push button start, **Bluetooth®** connectivity or satellite navigation.

Note: Any radio frequency transmitter equipment in your vehicle (such as cellular telephones and amateur radio transmitters) must keep to the parameters in the following illustrations and table. We do not provide any other special provisions or conditions for installations or use.

Car

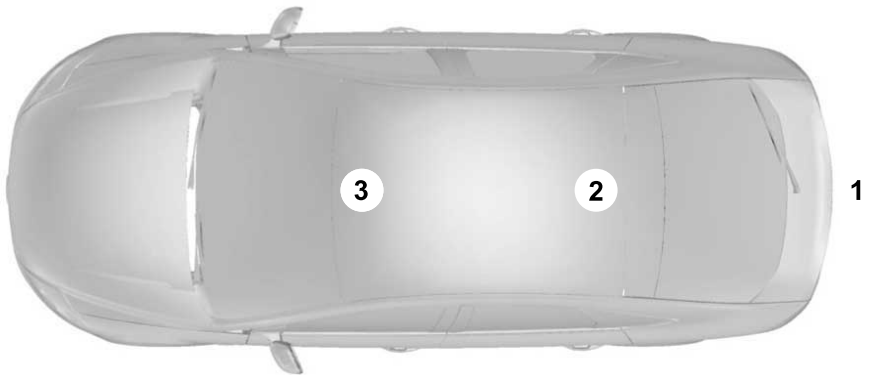

Appendices

Van

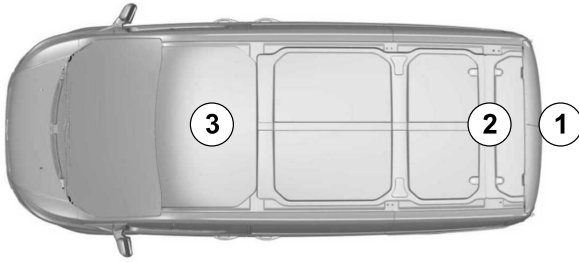

Truck

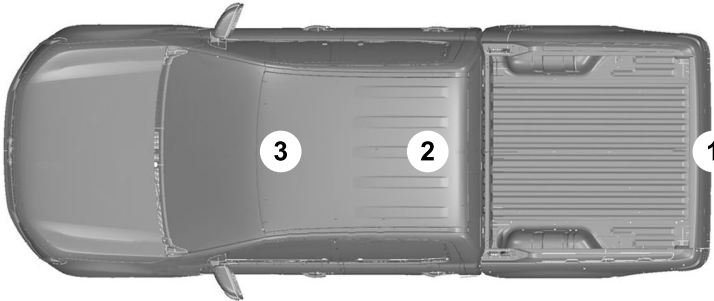

Appendices

Frequency Band MHz	Maximum Output Power Watt (Peak RMS)	Antenna Positions
1-30	50	1
50-54	50	2, 3
68-88	50	2, 3
142-176	50	2, 3
380-512	50	2, 3
806-870	10	2, 3

Note: After the installation of radio frequency transmitters, check for disturbances from and to all electrical equipment in your vehicle, both in the standby and transmit modes.

Check all electrical equipment:

- With the ignition ON.
- With the vehicle running.
- During a road test at various speeds.

Check that electromagnetic fields generated inside your vehicle cabin by the transmitter installed do not exceed applicable human exposure requirements.

Index

1

12V Battery.....	334
Changing the 12V Battery.....	334
Charging the 12V Battery.....	334
12V Battery – Troubleshooting.....	334
12V Battery – Information Messages.....	335
12V Battery – Warning Lamps.....	334

3

360 Degree Camera.....	227
360 Degree Camera Settings.....	229
360 Degree Camera Guide Lines.....	228
360 Degree Camera Limitations.....	227
360 Degree Camera Precautions.....	227
360 Degree Camera Settings.....	229
Switching the 360 Degree Camera On and Off.....	229
Switching the 360 Degree Camera View.....	229

A

A/C

See: Climate Control.....	132
---------------------------	-----

About This Publication.....	15
-----------------------------	----

ABS

See: Brakes.....	195
------------------	-----

Accessing Apps.....	384
---------------------	-----

Accessing Navigation.....	388
---------------------------	-----

Accessing the Passive Key Backup	
----------------------------------	--

Position.....	157
---------------	-----

Accessing the Trip Computer.....	129
----------------------------------	-----

AC Charging.....	174
------------------	-----

Connecting the Charger.....	174
-----------------------------	-----

Stopping Charging.....	177
------------------------	-----

Active Park Assist.....	230
-------------------------	-----

Active Park Assist – Troubleshooting.....	232
---	-----

Active Park Assist Precautions.....	230
-------------------------------------	-----

Active Park Assist –	
----------------------	--

Troubleshooting.....	232
----------------------	-----

Active Park Assist – Frequently Asked	
---------------------------------------	--

Questions.....	232
----------------	-----

Active Park Assist – Information	
----------------------------------	--

Messages.....	232
---------------	-----

Adaptive Cruise Control.....	234
------------------------------	-----

Adaptive Cruise Control –

Troubleshooting.....	246
----------------------	-----

Lane Centering.....	241
---------------------	-----

Predictive Speed Assist.....	244
------------------------------	-----

Predictive Speed Assist –

Troubleshooting.....	246
----------------------	-----

Adaptive Cruise Control Automatic

Cancellation.....	237
-------------------	-----

Adaptive Cruise Control Indicators.....	241
---	-----

Adaptive Cruise Control

Limitations.....	234
------------------	-----

Adaptive Cruise Control

Precautions.....	234
------------------	-----

Adaptive Cruise Control –

Troubleshooting.....	246
----------------------	-----

Adaptive Cruise Control – Information

Messages.....	246
---------------	-----

Adaptive Front Lighting.....	112
------------------------------	-----

How Does Adaptive Front Lighting

Work.....	112
-----------	-----

Switching Adaptive Front Lighting On and Off.....	112
---	-----

Switching the Headlamps for Driving on the	
--	--

Left or Right-Hand Side of the	
--------------------------------	--

Road.....	112
-----------	-----

Adjusting the Exterior Mirrors.....	119
-------------------------------------	-----

Adjusting the Headlamps.....	335
------------------------------	-----

Adjusting the Instrument Panel Lighting	
---	--

Brightness.....	114
-----------------	-----

Adjusting the Luggage Compartment	
-----------------------------------	--

Load Floor.....	298
-----------------	-----

Adjusting the Map.....	388
------------------------	-----

Changing the Format of the Map.....	388
-------------------------------------	-----

Zooming the Map In and Out.....	388
---------------------------------	-----

Adjusting the Seatbelt Height.....	47
------------------------------------	----

Adjusting the Seatbelts During	
--------------------------------	--

Pregnancy.....	46
----------------	----

Adjusting the Sound Settings.....	371
-----------------------------------	-----

Adjusting the Speed Limit	
---------------------------	--

Tolerance.....	263
----------------	-----

Adjusting the Steering Wheel.....	98
-----------------------------------	----

Adjusting the Volume.....	370
---------------------------	-----

Aid Mode.....	265
---------------	-----

How Does Aid Mode Work.....	266
-----------------------------	-----

What Is Aid Mode.....	265
-----------------------	-----

Airbag Precautions.....	51
-------------------------	----

Index

Airbags.....	49	App Requirements.....	384
Airbags – Troubleshooting.....	53	Apps.....	384
Airbags – Troubleshooting.....	53	Audio System.....	370
Airbags – Audible Warnings.....	53	Digital Audio Broadcasting Radio.....	372
Airbags – Warning Lamps.....	53	FM Radio.....	371
Air Conditioning		Traffic Announcements.....	373
See: Climate Control.....	132	Audio System Precautions.....	370
Air Conditioning System Capacity and Specification.....	361	Auto-Dimming Interior Mirror.....	118
Alert and Aid Mode.....	266	Auto-Dimming Interior Mirror	
How Does Alert and Aid Mode Work.....	266	Limitations.....	118
What Is Alert and Aid Mode.....	266	What Is the Auto-Dimming Interior Mirror.....	118
All-Wheel Drive.....	194	Auto Hold.....	209
All-Wheel Drive – Troubleshooting.....	194	Auto Hold Indicators.....	209
All-Wheel Drive Limitations.....	194	Autolamps.....	105
All-Wheel Drive Precautions.....	194	Autolamp Settings.....	105
All-Wheel Drive – Troubleshooting.....	194	What Are Autolamps.....	105
All-Wheel Drive – Information		Autolock.....	75
Messages.....	194	Autolock Requirements.....	75
Ambient Lighting.....	114	What Is Autolock.....	75
Adjusting Ambient Lighting.....	114	Automatically Releasing the Electric Parking Brake.....	198
Switching Ambient Lighting On and Off.....	114	Automatic Crash Shutoff.....	315
Anti-Lock Braking System.....	195	Re-Enabling Your Vehicle.....	315
Anti-Lock Braking System		What Is Automatic Crash Shutoff.....	315
Limitations.....	195	Automatic Emergency Braking.....	283
Anti-Theft Alarm System.....	94	Switching Automatic Emergency Braking On and Off.....	283
Arming the Anti-Theft Alarm System.....	95	What Is Automatic Emergency Braking.....	283
Disarming the Anti-Theft Alarm System.....	95	Automatic High Beam Control.....	107
How Does the Anti-Theft Alarm System Work.....	94	Automatic High Beam Control Indicators.....	108
What Are the Inclination Sensors.....	95	Automatic High Beam Control Limitations.....	108
What Are the Interior Sensors.....	94	Automatic High Beam Control Precautions.....	107
What Is the Anti-Theft Alarm System.....	94	Automatic High Beam Control Requirements.....	108
What Is the Battery Backup Alarm.....	95	How Does Automatic High Beam Control Work.....	107
What Is the Perimeter Alarm.....	94	Overriding Automatic High Beam Control.....	108
Anti-Theft Alarm System Settings.....	95	Switching Automatic High Beam Control On and Off.....	108
Setting the Alarm Security Level.....	95		
Switching Ask on Exit On and Off.....	95		
What Are the Alarm Security Levels.....	95		
What Is Ask on Exit.....	95		
Appendices.....	455		
Applying the Electric Parking Brake.....	198		
Applying the Electric Parking Brake in an Emergency.....	198		
App Precautions.....	384		

Index

Automatic High Beam Control – Troubleshooting.....	109
Automatic High Beam Control – Information Messages.....	109
Automatic Return to Park (P).....	192
Automatic Return to Park (P) Limitations.....	192
How Does Automatic Return to Park (P) Work.....	192
What Is Automatic Return to Park (P).....	192
Auto Mode.....	135
Auto Mode Indicators.....	135
Switching Auto Mode On and Off.....	135
Switching Dual Mode On and Off.....	136
Autounlock.....	74
Autounlock Requirements.....	74
What Is Autounlock.....	74
Autowipers.....	99
Adjusting the Sensitivity of the Rain Sensor.....	100
Autowipers Settings.....	99
What Are Autowipers.....	99
AWD See: All-Wheel Drive.....	194
B	
Battery Fuse Box.....	326
Accessing the Battery Fuse Box.....	326
Identifying the Fuses in the Battery Fuse Box.....	327
Locating the Battery Fuse Box.....	326
Blind Spot Assist.....	267
Blind Spot Assist Indicators.....	268
Blind Spot Assist Limitations.....	267
How Does Blind Spot Assist Work.....	267
What Is Blind Spot Assist.....	267
Blind Spot Information System.....	272
Blind Spot Information System – Troubleshooting.....	274
Blind Spot Information System Indicators.....	273
Blind Spot Information System Limitations.....	272
Blind Spot Information System Precautions.....	272
Blind Spot Information System Requirements.....	272
Blind Spot Information System – Troubleshooting.....	274
Blind Spot Information System – Information Messages.....	274
BlueCruise Alerts.....	252
BlueCruise Automatic Cancellation.....	252
BlueCruise.....	249
BlueCruise – Troubleshooting.....	254
In-Lane Repositioning.....	254
BlueCruise Indicators.....	253
BlueCruise Limitations.....	251
BlueCruise Precautions.....	249
BlueCruise Requirements.....	250
BlueCruise Settings.....	251
BlueCruise – Troubleshooting.....	254
BlueCruise – Information Messages.....	254
Bluetooth®.....	383
Body Control Module Fuse Box.....	327
Accessing the Body Control Module Fuse Box.....	327
Identifying the Fuses in the Body Control Module Fuse Box.....	328
Locating the Body Control Module Fuse Box.....	327
Body Styling Kit Precautions.....	340
Body Styling Kits.....	340
Bonnet Lock See: Opening and Closing the Hood.....	331
Booster Seats.....	44
Brake Coach.....	127
Brake Fluid Specification.....	196
Brake Over Accelerator.....	195
Brake Precautions.....	195
Brakes.....	195
Anti-Lock Braking System.....	195
Brakes – Troubleshooting.....	196
Brakes – Troubleshooting.....	196
Brakes – Frequently Asked Questions.....	197
Brakes – Warning Lamps.....	196
Breaking-In.....	307
C	
Canceling the Set Speed.....	239

Index

Canceling the Set Speed Limit.....	260
Capacities and Specifications.....	359
Center Console - GT.....	30
Center Display Limitations.....	375
Center Display Overview.....	375
Center Display Precautions.....	375
Center Display Settings.....	376
Changing a Road Wheel.....	358
Changing the Backup Battery.....	59
Changing the Language.....	128
Changing the Measurement Unit.....	128
Changing the Remote Control Battery - LHD.....	60
Changing the Remote Control Battery - RHD.....	62
Changing the Set Speed Limit.....	260
Changing the Temperature Unit.....	128
Changing the Tire Pressure Unit.....	128
Changing the Vehicle Wi-Fi Hotspot Name or Password.....	369
Charge Port Indicators.....	173
Charging a Device.....	152
Charging a Wireless Device.....	154
Charging Equipment.....	161
Charging Equipment Identification Symbols.....	186
Charging Your Vehicle.....	161
AC Charging.....	174
Charging Your Vehicle – Troubleshooting.....	187
DC Charging.....	178
Charging Your Vehicle Hints.....	186
Charging Your Vehicle Precautions.....	161
Charging Your Vehicle – Troubleshooting.....	187
Charging Your Vehicle – Frequently Asked Questions.....	189
Charging Your Vehicle – Information Messages.....	188
Charging Your Vehicle – Warning Lamps.....	187
Checking MyKey System Status.....	71
Checking the Brake Fluid.....	195
Checking the Coolant.....	332
Checking the Tire Pressures.....	346
Checking the Wiper Blades.....	101
Child Restraint Anchor Points.....	40
Locating the Child Restraint Lower Anchor Points.....	40
Locating the Child Restraint Top Tether Anchor Points.....	40
What Are the Child Restraint Anchor Points.....	40
Child Restraints.....	41
Child Restraint Position Information.....	41
Child Restraints Recommendation.....	43
Installing Child Restraints.....	44
Child Safety.....	39
Child Restraint Anchor Points.....	40
Child Restraints.....	41
Child Safety Locks.....	45
Child Safety Precautions.....	39
Cleaning the Exterior.....	336
Cleaning Camera Lenses and Sensors.....	337
Cleaning Chrome, Aluminium or Stainless Steel.....	336
Cleaning Headlamps and Rear Lamps.....	336
Cleaning Stripes or Graphics.....	337
Cleaning the Exterior Precautions.....	336
Cleaning the Underbody.....	337
Cleaning Wheels.....	336
Cleaning Windows and Wiper Blades.....	336
Cleaning the Interior.....	337
Cleaning Carpets and Floor Mats.....	338
Cleaning Displays and Screens.....	338
Cleaning Fabric.....	338
Cleaning Plastic.....	337
Cleaning Seatbelts.....	339
Cleaning Storage Compartments.....	339
Cleaning the Instrument Panel.....	337
Cleaning Vinyl.....	338
Clearing All MyKeys.....	71
Climate Control.....	132
Auto Mode.....	135
Climate Control Hints.....	136
Closing the Frunk.....	296
Closing the Frunk from Outside Your Vehicle.....	296
Closing the Liftgate.....	87
Closing the Hands-Free Liftgate.....	88

Index

Closing the Liftgate From Inside Your Vehicle.....	87
Closing the Liftgate From Outside Your Vehicle.....	87
Closing the Liftgate Using the Remote Control.....	88
Cold Weather Precautions.....	307
Connected Navigation.....	388
Connected Vehicle.....	365
Connected Vehicle – Troubleshooting.....	366
Connecting the Vehicle to a Mobile Network.....	365
Connected Vehicle Data.....	22
Connected Vehicle Limitations.....	365
Connected Vehicle Requirements.....	365
Connected Vehicle – Troubleshooting.....	366
Connected Vehicle – Frequently Asked Questions.....	366
Connecting a Bluetooth® Device.....	383
Connecting a Trailer.....	300
Tow Ball.....	300
Connecting the Vehicle to a Mobile Network.....	365
Connecting FordPass to the Modem.....	365
Enabling and Disabling the Modem.....	365
What Is the Modem.....	365
Connecting the Vehicle to a Wi-Fi Network.....	365
Connecting Your Phone.....	379
Cooling System Capacity and Specification.....	360
Crash and Breakdown Information.....	312
Automatic Crash Shutoff.....	315
Jump Starting the Vehicle.....	312
Post-Crash Alert System.....	314
Recovery Towing.....	315
Creating a MyKey.....	70
Creating a Personal Profile.....	386
Creating a Vehicle Wi-Fi Hotspot.....	368
Cross Traffic Alert.....	275
Cross Traffic Alert – Troubleshooting.....	277
Cross Traffic Alert Indicators.....	276
Cross Traffic Alert Limitations.....	275
Cross Traffic Alert Precautions.....	275
Cross Traffic Alert – Troubleshooting.....	277
Cross Traffic Alert – Information Messages.....	277
Cross Traffic Braking.....	205
Cross Traffic Braking – Troubleshooting.....	206
Cross Traffic Braking Indicators.....	206
Cross Traffic Braking Precautions.....	205
Cross Traffic Braking – Troubleshooting.....	206
Cross Traffic Braking – Frequently Asked Questions.....	207
Cross Traffic Braking – Information Messages.....	206
Cup Holders.....	155
Cup Holder Precautions.....	155
Customer Information.....	394
Radio Frequency Certification Labels.....	395
D	
Data Privacy.....	20
DC Charging.....	178
Connecting the Charger.....	178
Stopping Charging.....	179
Declaration of Conformity.....	394
Deleting a Personal Profile.....	387
Digital Audio Broadcasting Radio.....	372
Digital Audio Broadcasting Radio Limitations.....	372
Digital Audio Broadcasting Radio Settings.....	373
Selecting a Digital Audio Broadcasting Radio Station.....	373
Switching Service Linking On and Off.....	372
What Is Digital Audio Broadcasting Radio.....	372
What Is Service Linking.....	372
Directing the Flow of Air.....	134
Distance Alert.....	282
Adjusting the Sensitivity of Distance Alert.....	282
What Is Distance Alert.....	282
Distance Indication.....	281
Distance Indication Indicator.....	282

Index

Switching Distance Indication On and Off.....	282
What Is Distance Indication.....	281
Dog Guard.....	292
Installing the Dog Guard Behind the Front Seats.....	292
Installing the Dog Guard Behind the Rear Seats.....	292
Doors and Locks Audible Warnings.....	75
Doors and Locks.....	74
Autolock.....	75
Autounlock.....	74
Doors and Locks – Troubleshooting.....	75
Mislock.....	75
Operating the Doors From Inside Your Vehicle.....	74
Operating the Doors From Outside Your Vehicle.....	74
Doors and Locks – Troubleshooting.....	75
Doors and Locks – Frequently Asked Questions.....	77
Doors and Locks – Information Messages.....	76
Doors and Locks – Warning Lamps.....	75
Drive Mode Control.....	256
Drive Modes.....	256
Drive Modes.....	256
Active.....	256
Untame.....	256
Whisper.....	257
Driver Alert.....	286
Driver Alert – Troubleshooting.....	287
Driver Alert Indicators.....	287
Driver Alert Limitations.....	286
Driver Alert Precautions.....	286
Driver Alert – Troubleshooting.....	287
Driver Alert – Information Messages.....	287
Driving Hints.....	307
Driving in Special Conditions.....	307
Electric Vehicle.....	308
Driving in Special Conditions.....	307
Driving In Sand.....	308
Driving on Hilly or Sloping Terrain.....	308
Driving Through Mud and Water.....	308
Emergency Maneuvers.....	307
Driving on Snow and Ice.....	307
Driving Through Shallow Water.....	309

E

Easy Entry and Exit.....	84
eCall.....	57
eCall – Troubleshooting.....	59
eCall – Troubleshooting.....	59
eCall – Information Messages.....	59
eCall User Information.....	425
Electric Motor Audible Warnings.....	192
Electric Motor.....	190
Automatic Return to Park (P).....	192
Selector Positions.....	190
Temporary Neutral Mode.....	191
Electric Motor Precautions.....	190
Electric Parking Brake Audible Warning.....	199
Electric Parking Brake.....	198
Electric Parking Brake – Troubleshooting.....	199
Electric Parking Brake – Troubleshooting.....	199
Electric Parking Brake – Information Messages.....	200
Electric Parking Brake – Warning Lamps.....	199
Electric Power Steering.....	217
Electric Power Steering Adaptive Steering.....	217
Electric Power Steering Precautions.....	217
Electric Vehicle.....	308
Driving in Cold Weather.....	309
Maximizing Your Driving Range.....	308
Electromagnetic Compatibility.....	455
Emergency Call Indicators.....	58
Emergency Call Limitations.....	57
Emergency Call Requirements.....	57
Emergency Call System Data.....	23
Emergency Towing.....	318
Enabling Apps on an Android Device.....	385
Enabling Apps on an iOS Device.....	384
Enabling Local Hazard Information.....	259
Enabling or Disabling Personal Profiles.....	386
Enabling Remote Start.....	130
End User License Agreement.....	429
Energy Consumption Figures.....	159

Index

Energy Consumption Figures - Excluding: GT.....	159	Folding the Exterior Mirrors - Vehicles With: Manual Folding Mirrors.....	120
Energy Consumption Figures - GT.....	160	Folding the Exterior Mirrors - Vehicles With: Power Folding Mirrors.....	119
Entering a Parallel Parking Space.....	230	Ford Assistant.....	377
Entering a Perpendicular Parking Space.....	231	Ford Assistant – Frequently Asked Questions.....	377
Environment.....	24	Ford Assistant Settings.....	377
Evasive Steering Assist.....	283	Using Ford Assistant.....	377
Evasive Steering Assist Limitations.....	283	Ford Power-Up See: Software Update Settings.....	391
Switching Evasive Steering Assist On and Off.....	284	See: Vehicle Software Updates.....	391
What Is Evasive Steering Assist.....	283	Front Exterior - Excluding: GT.....	35
Event Data.....	21	Front Exterior - GT.....	36
Exiting a Parking Space.....	231	Front Parking Aid.....	220
Exterior Bulbs.....	335	Front Parking Aid Audible Warnings.....	221
Exterior Bulb Specification Chart.....	335	Front Parking Aid Limitations.....	221
Exterior Lamps.....	106	Locating the Front Parking Aid Sensors.....	221
Exterior Lamp Indicators.....	107	What is the Front Parking Aid.....	220
Exterior Lamps On Audible Warning.....	107	Front Seat Precautions.....	139
Switching the Daytime Running Lamps On and Off.....	106	Front Seats.....	139
Switching Welcome Lighting On and Off.....	106	Heated Seats.....	145
Using the Rear Fog Lamps.....	106	Manual Seats.....	140
Using the Turn Signal Lamps.....	106	Power Seats.....	142
Exterior Lighting Control.....	104	Fuse Precautions.....	320
Exterior Lighting.....	104	Fuses.....	320
Adaptive Front Lighting.....	112	Battery Fuse Box.....	326
Autolamps.....	105	Body Control Module Fuse Box.....	327
Automatic High Beam Control.....	107	Fuses – Troubleshooting.....	330
Automatic High Beam Control – Troubleshooting.....	109	Under Hood Fuse Box.....	320
Exterior Lamps.....	106	Fuses – Troubleshooting.....	330
Glare Free Lighting.....	109	Fuses – Frequently Asked Questions.....	330
Glare Free Lighting – Troubleshooting.....	112		
Headlamps.....	104	G	
Headlamps – Troubleshooting.....	105	Glare Free Lighting.....	109
Exterior Mirrors.....	119	Glare Free Lighting Indicators.....	111
		Glare Free Lighting Limitations.....	111
F		Glare Free Lighting Precautions.....	110
Fastening and Unfastening the		Glare Free Lighting Requirements.....	110
Seatbelts.....	46	How Does Glare Free Lighting Work.....	109
Floor Mats.....	310	Overriding Glare Free Lighting.....	111
FM Radio.....	371	Switching Glare Free Lighting On and Off.....	111
FM Radio Limitations.....	371		
Selecting an FM Radio Station.....	372		

Index

Glare Free Lighting – Troubleshooting.....112	Horn.....98
Glare Free Lighting – Information Messages.....112	How Does Active Park Assist Work.....230
Glasses Holder.....155	How Does Adaptive Cruise Control With Stop and Go Work.....234
Locating the Glasses Holder.....155	How Does All-Wheel Drive Work.....194
Global Opening and Closing.....115	How Does Auto Hold Work.....209
Switching Global Closing On and Off.....116	How Does Blind Spot Information System Work.....272
Switching Global Opening On and Off.....116	How Does BlueCruise Work.....249
Using Global Closing.....116	How Does Cross Traffic Alert Work.....275
Using Global Opening.....115	How Does Cross Traffic Braking Work.....205
What Is Global Opening and Closing.....115	How Does Driver Alert Work.....286
Glove Compartment.....155	How Does Easy Entry and Exit Work.....84
Opening the Glove Compartment.....155	How Does eCall Work.....57
H	How Does Hill Start Assist Work.....208
Headlamp Adjusting	How Does Pedestrian Protection Work.....54
See: Adjusting the Headlamps.....335	How Does Pre-Collision Assist Work.....278
Headlamps.....104	How Does Reverse Brake Assist Work.....201
Adjusting the Level of the Headlamps.....104	How Does Stability Control Work.....213
Headlamp Indicators.....104	How Does the 360 Degree Camera Work.....227
Switching Headlamp Exit Delay On and Off.....104	How Does the Intelligent Speed Limiter Work.....262
Using the High Beam Headlamps.....104	How Does the Lane Keeping System Work.....264
Headlamps – Troubleshooting.....105	How Does the Rear Occupant Alert System Work.....148
Headlamps – Frequently Asked Questions.....105	How Does the Safety Canopy™ Work.....50
Heated Seats.....145	How Does the Speed Limiter Work.....260
Heated Seat Precautions.....145	How Does Traction Control Work.....211
Switching the Heated Seats On and Off.....145	How Does Traffic Sign Recognition Work.....288
Heating	How Does Trailer Sway Control Work.....306
See: Climate Control.....132	How Does Walk Away Lock Work.....83
High Voltage Battery Gauge.....123	How Does Wrong Way Alert Work.....290
High Voltage Battery.....158	How Do Personal Profiles Work.....386
High Voltage Battery – Troubleshooting.....160	How Do the Front Airbags Work.....49
High Voltage Battery Precautions.....158	How Do the Knee Airbags Work.....50
High Voltage Battery – Troubleshooting.....160	
High Voltage Battery – Warning Lamps.....160	
Hill Start Assist.....208	
Hill Start Assist Precautions.....208	
Hood Lock	
See: Opening and Closing the Hood.....331	

Index

How Do the Side Airbags Work.....	49
I	
Identifying Fuse Types.....	330
Identifying the Climate Control Unit.....	132
Inflating the Tires.....	346
In-Lane Repositioning.....	254
How Does In-Lane Repositioning Work.....	254
In-Lane Repositioning Indicators.....	254
Switching In-Lane Repositioning On and Off.....	254
Installing and Removing the Luggage Compartment Cargo Net.....	297
Installing and Removing the Luggage Compartment Cover.....	297
Installing the Vehicle Identification Card.....	364
Instrument Cluster Display.....	127
Instrument Cluster Indicators.....	126
Instrument Cluster.....	121
Instrument Cluster Overview - Excluding: GT.....	121
Instrument Cluster Overview - GT.....	122
Instrument Cluster Warning Lamps.....	124
Instrument Panel - GT, LHD.....	28
Instrument Panel - GT, RHD.....	29
Instrument Panel - LHD, Excluding: GT.....	26
Instrument Panel - RHD, Excluding: GT.....	27
Intelligent Speed Limiter Audible Warnings.....	263
Intelligent Speed Limiter Indicators.....	263
Intelligent Speed Limiter.....	262
Intelligent Speed Limiter Precautions.....	262
Intentionally Exceeding the Set Speed Limit.....	260
Interior Air Quality.....	138
Interior Bulbs.....	335
Interior Bulb Specification Chart.....	335
Interior Lamp Function.....	113
Switching the Interior Lamp Function On and Off.....	113
What Is the Interior Lamp Function.....	113
Interior Lighting.....	113
Ambient Lighting.....	114
Interior Lamp Function.....	113
Interior Lighting – Troubleshooting.....	114
Interior Lighting – Troubleshooting.....	114
Interior Lighting – Frequently Asked Questions.....	114
Interior Mirror.....	118
Auto-Dimming Interior Mirror.....	118
Interior Mirror Precautions.....	118
Introduction.....	15
J	
Jump Starting the Vehicle.....	312
Jump Starting Precautions.....	312
Jump Starting the Vehicle.....	314
Preparing the Vehicle.....	312
K	
Keyless Entry.....	78
Keyless Entry – Troubleshooting.....	79
Keyless Entry Keypad.....	80
Keyless Entry Keypad – Troubleshooting.....	82
Keyless Entry Keypad Limitations.....	80
Keyless Entry Keypad Master Access Code.....	80
Keyless Entry Keypad Personal Access Codes.....	80
Keyless Entry Keypad – Troubleshooting.....	82
Keyless Entry Keypad – Frequently Asked Questions.....	82
Keyless Entry Limitations.....	78
Keyless Entry Settings.....	78
Keyless Entry – Troubleshooting.....	79
Keyless Entry – Frequently Asked Questions.....	79
Keys and Remote Controls.....	60
Keys and Remote Controls – Troubleshooting.....	64

Index

Keys and Remote Controls – Troubleshooting.....	64
Keys and Remote Controls – Information Messages.....	64

L

Lane Centering.....	241
How Does Lane Centering Work.....	241
Lane Centering Alerts.....	243
Lane Centering Automatic Cancellation.....	243
Lane Centering Indicators.....	244
Lane Centering Limitations.....	242
Lane Centering Manual Cancellation.....	243
Lane Centering Precautions.....	242
Lane Centering Requirements.....	242
Switching Lane Centering On and Off.....	243
Lane Keeping System Indicators.....	266
Lane Keeping System.....	264
Aid Mode.....	265
Alert and Aid Mode.....	266
Blind Spot Assist.....	267
Lane Keeping System – Troubleshooting.....	269
Lane Keeping System Limitations.....	264
Lane Keeping System Precautions.....	264
Lane Keeping System Settings.....	265
Lane Keeping System – Troubleshooting.....	269
Lane Keeping System – Frequently Asked Questions.....	270
Lane Keeping System – Information Messages.....	269
Liftgate.....	85
Closing the Liftgate.....	87
Liftgate – Troubleshooting.....	89
Opening the Liftgate.....	85
Liftgate Obstacle Detection.....	89
Liftgate Precautions.....	85
Liftgate – Troubleshooting.....	89
Liftgate – Frequently Asked Questions.....	91
Liftgate – Information Messages.....	90
Liftgate – Warning Lamps.....	89
Linking or Unlinking a Personal Profile.....	386
Live Traffic.....	388
Switching Live Traffic On and Off.....	388
What Is Live Traffic.....	388
Load Carrying.....	292
Dog Guard.....	292
Roof Rack.....	292
Tow Bar Mounted Carrier.....	293
Load Carrying Precautions.....	292
Local Hazard Information Indicators.....	259
Local Hazard Information.....	259
Locating the 360 Degree Cameras.....	227
Locating the Blind Spot Information System Sensors.....	273
Locating the Brake Fluid Reservoir.....	195
Locating the Charge Port.....	172
Locating the Cross Traffic Alert Sensors.....	276
Locating the Keyless Entry Keypad.....	80
Locating the Memory Function Buttons.....	150
Locating the Power Outlets.....	153
Locating the Pre-Collision Assist Sensors.....	280
Locating the Rear View Camera.....	224
Locating the Tire label.....	343
Locating the Tire Sealant and Inflator Kit.....	349
Locating the USB Ports.....	151
Locating the Wireless Accessory Charger.....	154
Locating Your Vehicle.....	60
Locking the Rear Window Controls.....	116
Luggage Compartment Anchor Points.....	298
Locating the Luggage Compartment Anchor Points.....	298
Luggage Compartment.....	295
Closing the Frunk.....	296
Luggage Compartment Anchor Points.....	298
Luggage Compartment – Troubleshooting.....	299
Opening the Frunk.....	295
Luggage Compartment Precautions.....	295

Index

Luggage Compartment – Troubleshooting.....	299
Luggage Compartment – Warning Lamps.....	299
M	
Maintenance.....	331
12V Battery.....	334
12V Battery – Troubleshooting.....	334
Exterior Bulbs.....	335
Interior Bulbs.....	335
Maintenance Precautions.....	331
Making and Receiving a Phone Call.....	380
Manually Making an Emergency Call.....	57
Manually Releasing the Electric Parking Brake.....	198
Manual Seats.....	140
Adjusting the Head Restraint.....	140
Adjusting the Seat Backrest.....	141
Adjusting the Seat Height.....	142
Folding the Seat Backrest.....	147
Head Restraint Components.....	140
Installing the Head Restraint.....	141
Moving the Seat Backward and Forward.....	141
Removing the Head Restraint.....	141
Unfolding the Seat Backrest.....	147
Memory Function.....	150
Memory Function Precautions.....	150
Mislock.....	75
Mislock Limitations.....	75
Switching Mislock On and Off.....	75
What Is Mislock.....	75
Mobile Communications Equipment.....	424
Mobile Device Data.....	22
Muting the Audio.....	371
MyKey Settings.....	69
Configurable MyKey Settings.....	69
Non-Configurable MyKey Settings.....	69
MyKey – Troubleshooting.....	72
MyKey – Frequently Asked Questions.....	73
MyKey – Information Messages.....	72
MyKey™.....	69
MyKey Settings.....	69
MyKey – Troubleshooting.....	72
N	
Navigation Map Updates.....	388
Navigation.....	388
Adjusting the Map.....	388
Live Traffic.....	388
Route Guidance.....	389
Setting a Destination.....	388
Waypoints.....	389
O	
One Pedal Drive Indicators.....	258
One Pedal Drive Limitations.....	258
One Pedal Drive.....	258
One Pedal Drive Precautions.....	258
Opening and Closing the Hood.....	331
Opening and Closing the Windows.....	115
Opening the Frunk.....	295
Opening the Frunk from Inside Your Vehicle.....	295
Opening the Frunk from Outside Your Vehicle.....	295
Opening the Frunk Using the Remote Control.....	296
Opening the Liftgate.....	85
Opening the Hands-Free Liftgate.....	86
Opening the Liftgate From Inside Your Vehicle.....	85
Opening the Liftgate From Outside Your Vehicle.....	85
Opening the Liftgate Using the Remote Control.....	86
Operating the Doors From Inside Your Vehicle.....	74
Opening the Doors From Inside Your Vehicle.....	74
Unlocking and Locking the Doors Using the Central Locking.....	74
Operating the Doors From Outside Your Vehicle.....	74
Opening and Closing the Doors.....	74
Unlocking and Locking the Doors Using the Remote Control.....	74

Index

OTA	
See: Software Update Settings.....	391
See: Vehicle Software Updates.....	391
Overriding Cross Traffic Braking.....	206
Overriding Reverse Brake Assist.....	202
Overriding the Set Speed.....	241
Over the air	
See: Software Update Settings.....	391
Over-the-air	
See: Software Update Settings.....	391
See: Vehicle Software Updates.....	391
See: Vehicle Software Updates.....	391
P	
Parking Aid Indicators.....	223
Parking Aid Precautions.....	219
Parking Aids.....	219
Front Parking Aid.....	220
Parking Aids – Troubleshooting.....	223
Rear Parking Aid.....	220
Side Parking Aid.....	221
Parking Aids – Troubleshooting.....	223
Parking Aids – Information	
Messages.....	223
Passive Anti-Theft System.....	94
How Does the Passive Anti-Theft System	
Work.....	94
What Is the Passive Anti-Theft	
System.....	94
Pedestrian Alert System.....	56
Pedestrian Protection Indicators.....	55
Pedestrian Protection.....	54
Pedestrian Protection Precautions.....	54
Performance Vehicle Precautions.....	307
Performing a System Reset.....	393
Personalized Settings.....	128
Personal Profiles.....	386
Phone as a Key Limitations.....	65
Phone as a Key.....	65
Phone as a Key – Troubleshooting.....	67
Phone as a Key – Troubleshooting.....	67
Phone as a Key – Frequently Asked	
Questions.....	67
Phone Menu.....	379
Phone.....	379
Phone Precautions.....	379
Playing Media Using Bluetooth®.....	383
Playing Media Using the USB Port.....	151
Playing or Pausing the Audio	
Source.....	370
Post-Collision Braking.....	315
Post-Crash Alert System.....	314
How Does the Post-Crash Alert System	
Work.....	314
Post-Crash Alert System Limitations.....	315
Switching the Post-Crash Alert System	
Off.....	315
What Is the Post-Crash Alert System.....	314
Power Gauge - GT.....	123
Powering Off.....	156
Power Outlet.....	153
Power Outlet Precautions.....	153
Power Seats.....	142
Adjusting the Head Restraint.....	142
Adjusting the Lumbar Support.....	144
Adjusting the Seat Backrest.....	144
Adjusting the Seat Height.....	144
Head Restraint Components.....	142
Installing the Head Restraint.....	144
Moving the Seat Backward and	
Forward.....	144
Removing the Head Restraint.....	143
Pre-Collision Assist Limitations.....	279
Pre-Collision Assist Precautions.....	278
Pre-Collision Assist.....	278
Automatic Emergency Braking.....	283
Distance Alert.....	282
Distance Indication.....	281
Evasive Steering Assist.....	283
Pre-Collision Assist –	
Troubleshooting.....	284
Pre-Collision Assist –	
Troubleshooting.....	284
Pre-Collision Assist – Frequently Asked	
Questions.....	285
Pre-Collision Assist – Information	
Messages.....	284
Pre-Collision Assist – Warning	
Lamps.....	284
Predictive Speed Assist.....	244
How Does Predictive Speed Assist	
Work.....	244
Predictive Speed Assist Alerts.....	245
Predictive Speed Assist Indicators.....	245
Predictive Speed Assist Limitations.....	245

Index

Predictive Speed Assist Precautions.....	244
Switching Predictive Speed Assist Mode On and Off.....	245
Predictive Speed Assist – Troubleshooting.....	246
Predictive Speed Assist – Information Messages.....	246
Preparing Your Vehicle for Storage.....	341
Preserving Your High Voltage Battery.....	158
Programming a MyKey.....	71
Programming the Remote Control.....	64
Programming Your Phone.....	65
Protecting the Environment.....	24
R	
Radio Frequency Certification Labels.....	395
Blind Spot Information System Sensors.....	395
Cruise Control Module.....	399
Remote Function Actuator.....	398
SYNC.....	403
Telematics Control Unit.....	409
Tire Pressure Monitoring System Sensors.....	411
Wireless Accessory Charging Module.....	417
REACH.....	394
Rear Cross Traffic Braking See: Cross Traffic Braking.....	205
Rear Exterior - Excluding: GT.....	37
Rear Exterior - GT.....	38
Rear Occupant Alert System Audible Warnings.....	149
Rear Occupant Alert System Indicators.....	149
Rear Occupant Alert System Limitations.....	148
Rear Occupant Alert System Precautions.....	148
Rear Occupant Alert System.....	148
Rear Parking Aid.....	220
Locating the Rear Parking Aid Sensors.....	220
Rear Parking Aid Audible Warnings.....	220
Rear Parking Aid Limitations.....	220
What is the Rear Parking Aid.....	220
Rear Seats.....	146
Manual Seats.....	146
Rear View Camera Guide Lines.....	224
Rear View Camera Object Distance Indicators.....	225
Rear View Camera Precautions.....	224
Rear View Camera.....	224
Rear View Camera Settings.....	225
Rear View Camera Settings.....	225
Switching Rear View Camera Delay On and Off.....	225
Zooming the Rear View Camera In and Out.....	225
Rebooting the Center Display.....	376
Recalling a Preset Position.....	150
Recovery Towing.....	315
Accessing the Front Towing Point.....	315
Accessing the Rear Towing Point.....	316
Installing the Towing Eye.....	316
Locating the Towing Eye.....	316
Recycling and Disposing of the High Voltage Battery.....	159
Releasing the Electric Parking Brake if the Vehicle Battery Has Run Out of Charge.....	199
Remote Control Limitations.....	60
Remotely Starting and Stopping the Vehicle.....	130
Remote Start Limitations.....	130
Remote Start Precautions.....	130
Remote Start.....	130
Remote Start Settings.....	131
Removing Your Vehicle From Storage.....	342
Replacement Parts Recommendation.....	424
Replacing a Lost Key or Remote Control.....	64
Replacing the Cabin Air Filter.....	138
Replacing the Front Wiper Blades.....	101
Replacing the Rear Wiper Blades.....	101
Resetting the Trip Computer.....	129
Resetting Tire Pressure Monitoring System.....	355
Restarting the Vehicle After Powering Off.....	156
Resuming the Set Speed Limit.....	260
Resuming the Set Speed.....	239

Index

Reverse Brake Assist Indicators.....	202
Reverse Brake Assist Precautions.....	201
Reverse Brake Assist.....	201
Reverse Brake Assist – Troubleshooting.....	203
Reverse Brake Assist – Troubleshooting.....	203
Reverse Brake Assist – Frequently Asked Questions.....	204
Reverse Brake Assist – Information Messages.....	203
Reverse Wipe.....	100
Reverse Wipe Settings.....	100
What Is Reverse Wipe.....	100
Rollover Warning.....	394
Roof Rack.....	292
Roof Rack Load Capacities.....	293
Roof Rack Precautions.....	292
Route Guidance.....	389
Adjusting the Guidance Prompt Volume.....	389
Canceling Route Guidance.....	390
Repeating an Instruction.....	390
Running-In See: Breaking-In.....	307
S	
Saving a Preset Position.....	150
Seatbelt Precautions.....	46
Seatbelt Reminder.....	47
Checking Seatbelt Status.....	47
Seatbelt Reminder Audible Warnings.....	47
Seatbelt Reminder Indicators.....	47
Switching the Seatbelt Reminder On and Off.....	47
Seatbelts.....	46
Seatbelt Reminder.....	47
Seatbelts – Troubleshooting.....	48
Seatbelts – Troubleshooting.....	48
Seatbelts – Information Messages.....	48
Security.....	94
Anti-Theft Alarm System.....	94
Anti-Theft Alarm System Settings.....	95
Passive Anti-Theft System.....	94
Security – Troubleshooting.....	96
Security – Troubleshooting.....	96
Security – Frequently Asked Questions.....	97
Security – Information Messages.....	96
Selecting a Drive Mode.....	256
Selecting a Personal Profile.....	387
Selecting the Audio Source.....	370
Selector Positions.....	190
Drive (D).....	190
Low (L).....	191
Neutral (N).....	190
Park (P).....	190
Reverse (R).....	190
Sending and Receiving a Text Message.....	381
Service Data.....	21
Setting a Destination.....	388
Setting a Destination Using a Point of Interest.....	389
Setting a Destination Using a Predictive Destination.....	389
Setting a Destination Using a Recent Destination.....	389
Setting a Destination Using a Saved Destination.....	389
Setting a Destination Using the Map Screen.....	389
Setting a Destination Using the Text Entry Screen.....	388
Setting a Memory Preset.....	370
Settings Data.....	22
Setting the Adaptive Cruise Control Gap.....	238
Setting the Adaptive Cruise Control Speed.....	237
Setting the Blower Motor Speed.....	134
Setting the Charging Schedule and Preferences.....	180
Setting the Clock and Date.....	371
Setting the Liftgate Opening Height.....	87
Setting the Speed Limit.....	260
Setting the Temperature.....	134
Setting the Traffic Sign Recognition Speed Tolerance.....	289
Setting the Traffic Sign Recognition Speed Warning.....	289
Shifting Your Vehicle Into Gear.....	191

Index

Side Parking Aid.....	221	Switching All of the Interior Lamps On and Off.....	113
Locating the Side Parking Aid		Switching Android Auto On and Off.....	385
Sensors.....	222	Switching Apple CarPlay On and Off.....	385
Side Parking Aid Audible Warnings.....	222	Switching Auto Hold On and Off.....	209
Side Parking Aid Limitations.....	221	Switching Blind Spot Information System On and Off.....	273
What is the Side Parking Aid.....	221	Switching BlueCruise On and Off.....	251
Sitting in the Correct Position.....	139	Switching Climate Control On and Off.....	132
Software Update Indicators.....	392	Switching Cross Traffic Alert On and Off.....	275
Software Update Settings.....	391	Switching Cross Traffic Braking On and Off.....	206
Software Update		Switching Defrost On and Off.....	132
See: Software Update Settings.....	391	Switching Driver Alert On and Off.....	287
See: Vehicle Software Updates.....	391	Switching Easy Entry and Exit On and Off.....	84
Speed Limiter Audible Warnings.....	261	Switching From Adaptive Cruise Control to Cruise Control.....	241
Speed Limiter Indicators.....	260	Switching From Intelligent Speed Limiter to Speed Limiter.....	263
Speed Limiter Precautions.....	260	Switching Maximum Cooling On and Off.....	133
Speed Limiter.....	260	Switching Maximum Defrost On and Off.....	132
Speedometer.....	123	Switching One Pedal Drive On and Off.....	258
Stability Control Indicator.....	216	Switching Parking Aid On and Off.....	219
Stability Control.....	213	Switching Pre-Collision Assist On and Off.....	280
Starting and Powering Off		Switching Rear Occupant Alert System On and Off.....	148
Precautions.....	156	Switching Recirculated Air On and Off.....	132
Starting and Powering Off.....	156	Switching Repeat Mode On and Off.....	370
Starting and Powering Off – Troubleshooting.....	157	Switching Reverse Brake Assist On and Off.....	202
Starting and Powering Off – Troubleshooting.....	157	Switching Shuffle Mode On and Off.....	370
Starting and Powering Off – Frequently Asked Questions.....	157	Switching Stability Control On and Off.....	214
Starting the Vehicle.....	156	Switching Text Message Notification On and Off.....	382
Status Bar.....	375		
Steering.....	217		
Electric Power Steering.....	217		
Steering – Troubleshooting.....	218		
Steering – Troubleshooting.....	218		
Steering – Information Messages.....	218		
Steering Wheel.....	25		
Stopping the Liftgate Movement.....	89		
Storage.....	155		
Cup Holders.....	155		
Glasses Holder.....	155		
Glove Compartment.....	155		
Storing Your Vehicle.....	341		
Switching Active Park Assist On and Off.....	230		
Switching Adaptive Cruise Control On and Off.....	236		
Switching Air Conditioning On and Off.....	132		

Index

Switching the Audio Unit On and Off.....	370
Switching the Electric Heater On and Off.....	133
Switching the Front Interior Lamps On and Off.....	113
Switching the Hazard Flashers On and Off.....	312
Switching the Heated Mirrors On and Off.....	134
Switching the Heated Rear Window On and Off.....	133
Switching the Heated Steering Wheel On and Off.....	98
Switching the Heated Windshield On and Off.....	133
Switching the Intelligent Speed Limiter On and Off.....	262
Switching the Lane Keeping System Mode.....	265
Switching the Lane Keeping System On and Off.....	265
Switching the Passenger Airbag On and Off.....	52
Switching the Rear Interior Lamps On and Off.....	113
Switching the Rear Window Wiper On and Off.....	100
Switching the Speed Limiter On and Off.....	260
Switching Traction Control On and Off.....	211
Switching Walk Away Lock On and Off.....	83
Switching Wrong Way Alert On and Off.....	290
Symbols Glossary.....	17
Symbols Used on Your Vehicle.....	17
System Update See: Software Update Settings.....	391
See: Vehicle Software Updates.....	391
T	
Technical Specifications See: Capacities and Specifications.....	359
Temporary Neutral Mode.....	191
Entering Temporary Neutral Mode.....	191
Exiting Temporary Neutral Mode.....	192
How Does Temporary Neutral Mode Work.....	191
Temporary Neutral Mode Limitations.....	191
What Is Temporary Neutral Mode.....	191
Third Party Software Copyright Acknowledgment.....	394
Tire Care.....	346
Tire Pressure Monitoring System Limitations.....	355
Tire Pressure Monitoring System Precautions.....	355
Tire Pressure Monitoring System.....	355
Tire Pressure Monitoring System – Troubleshooting.....	356
Tire Pressure Monitoring System – Troubleshooting.....	356
Tire Pressure Monitoring System – Information Messages.....	357
Tire Pressure Monitoring System – Warning Lamps.....	356
Tire Pressure Specifications.....	346
Tire Rotation.....	348
Tire Sealant and Inflator Kit Components.....	349
Tire Sealant and Inflator Kit Precautions.....	349
Tire Sealant and Inflator Kit.....	349
Tow Ball.....	300
Attaching the Tow Ball Arm.....	301
Detaching the Tow Ball Arm.....	300
Tow Ball Precautions.....	300
Tow Bar Mounted Carrier.....	293
Tow Bar Mounted Carrier Precautions.....	293
Tow Bar Mounted Load Capacities.....	294
Towing a Trailer Limitations.....	303
Towing a Trailer Precautions.....	303
Towing a Trailer.....	303
Towing Weights and Dimensions.....	304
Towing Weights and Dimensions.....	304
Tow Bar Dimensions.....	304
Towing Your Vehicle Precautions.....	318
Towing Your Vehicle.....	318
Towing Your Vehicle – Troubleshooting.....	319

Index

Towing Your Vehicle – Troubleshooting.....	319
Towing Your Vehicle – Information Messages.....	319
Traction Control Indicator.....	211
Traction Control.....	211
Traction Control – Troubleshooting.....	212
Traction Control – Troubleshooting.....	212
Traction Control – Information Messages.....	212
Traction Control – Warning Lamps.....	212
Traffic Announcements.....	373
Switching Traffic Announcements On and Off.....	373
Traffic Sign Recognition Indicators.....	289
Traffic Sign Recognition Limitations.....	288
Traffic Sign Recognition Precautions.....	288
Traffic Sign Recognition.....	288
Traffic Sign Recognition – Troubleshooting.....	289
Traffic Sign Recognition – Troubleshooting.....	289
Traffic Sign Recognition – Frequently Asked Questions.....	289
Traffic Sign Recognition – Information Messages.....	289
Trailer Sway Control Precautions.....	306
Trailer Sway Control.....	306
Trailer Towing Hints.....	303
Transporting the Vehicle.....	316
Trip Computer.....	129
Trip Data.....	129
Tyre Pressure Specifications See: Tyre Pressure Specifications.....	346
U	
Under Hood Fuse Box.....	320
Accessing the Under Hood Fuse Box.....	320
Identifying the Fuses in the Under Hood Fuse Box.....	321
Locating the Under Hood Fuse Box.....	320
Under Hood Overview.....	331
USB Ports.....	151
Using Auto Hold.....	209
Using FordPass and Charging.....	185
Using Keyless Entry.....	78
Using Snow Chains.....	344
Using Summer Tires.....	343
Using the Backup Start Passcode.....	66
Using the Frunk Emergency Release.....	296
Using the Keyless Entry Keypad.....	81
Using the Remote Control.....	60
Using the Tire Sealant and Inflator Kit.....	350
Using the Valet Mode.....	66
Using This Publication.....	16
Using Winter Tires.....	343
V	
Vehicle Care.....	336
Cleaning the Exterior.....	336
Cleaning the Interior.....	337
General Information.....	336
Vehicle Dimensions.....	359
Vehicle Identification Number.....	363
Locating the Vehicle Identification Number.....	363
Vehicle Identification Plate.....	363
Locating the Vehicle Identification Plate.....	363
Vehicle Identification Plate Overview.....	363
Vehicle Identification.....	363
Vehicle Identification Number.....	363
Vehicle Identification Plate.....	363
Vehicle Interior - GT, LHD.....	33
Vehicle Interior - GT, RHD.....	34
Vehicle Interior - LHD, Excluding: GT.....	31
Vehicle Interior - RHD, Excluding: GT.....	32
Vehicle Range Display.....	123
Vehicle Software Updates.....	391
Vehicle System Reset.....	393
Vehicle Wi-Fi Hotspot – Troubleshooting.....	369
Vehicle Wi-Fi Hotspot – Frequently Asked Questions.....	369

Index

Vehicle Wi-Fi Hotspot.....	368	What Is MyKey.....	69
Vehicle Wi-Fi Hotspot – Troubleshooting.....	369	What Is One Pedal Drive.....	258
Ventilation		What Is Pedestrian Protection.....	54
See: Climate Control.....	132	What Is Phone as a Key.....	65
Viewing the Tire Pressures.....	355	What Is Pre-Collision Assist.....	278
Visual Search.....	25	What Is Remote Start.....	130
Voice Interaction.....	377	What Is Reverse Brake Assist.....	201
Ford Assistant.....	377	What Is the 360 Degree Camera.....	227
W		What Is the Cabin Air Filter.....	138
Walk Away Lock Limitations.....	83	What Is the Electric Parking Brake.....	198
Walk Away Lock.....	83	What Is the High Voltage Battery.....	158
Washer Fluid Specification.....	361	What Is the Intelligent Speed Limiter.....	262
Washers.....	102	What Is the Keyless Entry Keypad.....	80
Adding Washer Fluid.....	103	What Is the Lane Keeping System.....	264
Switching the Courtesy Wipe On and Off.....	102	What Is the Memory Function.....	150
Using the Rear Window Washer.....	102	What Is the Pedestrian Alert System.....	56
Using the Windshield Washer.....	102	What Is the Power Outlet.....	153
Washer Fluid Specification.....	103	What Is the Rear Occupant Alert System.....	148
Washer Precautions.....	102	What Is the Rear View Camera.....	224
Washers		What Is the Tire Pressure Monitoring System.....	355
See: Wipers and Washers.....	99	What Is the Tire Sealant and Inflator Kit.....	349
Waxing Your Vehicle.....	339	What Is the Wireless Accessory Charger.....	154
Waypoints.....	389	What Is Traction Control.....	211
Adding a Waypoint.....	389	What Is Traffic Sign Recognition.....	288
Editing Waypoints.....	389	What Is Walk Away Lock.....	83
What Are the Instrument Cluster Indicators.....	125	What Is Wrong Way Alert.....	290
What Are the Instrument Cluster Warning Lamps.....	124	Wheel and Tire Information.....	343
What Is AC Charging.....	161	Wheel Nuts.....	358
What Is a Connected Vehicle.....	365	Wi-Fi	
What Is Active Park Assist.....	230	See: Changing the Vehicle Wi-Fi Hotspot Name or Password.....	369
What Is Blind Spot Information System.....	272	See: Connecting the Vehicle to a Wi-Fi Network.....	365
What Is BlueCruise.....	249	See: Creating a Vehicle Wi-Fi Hotspot.....	368
What Is Cross Traffic Alert.....	275	See: Vehicle Wi-Fi Hotspot.....	368
What Is Cross Traffic Braking.....	205	Window Bounce-Back.....	116
What Is DC Charging.....	161	Overriding Window Bounce-Back.....	116
What Is Drive Mode Control.....	256	What Is Window Bounce-Back.....	116
What Is Driver Alert.....	286	Windows.....	115
What Is eCall.....	57	Global Opening and Closing.....	115
What Is Hill Start Assist.....	208	Window Bounce-Back.....	116
What Is Keyless Entry.....	78		
What Is Local Hazard Information.....	259		

Index

Wipers and Washers – Troubleshooting.....	103
Wipers and Washers – Frequently Asked Questions.....	103
Wipers and Washers – Warning Lamps.....	103
Wipers and Washers.....	99
Autowipers.....	99
Reverse Wipe.....	100
Washers.....	102
Wipers.....	99
Wipers and Washers – Troubleshooting.....	103
Wipers.....	99
Switching Windshield Wipers On and Off.....	99
Wiper Precautions.....	99
Wireless Accessory Charger Precautions.....	154
Wireless Accessory Charger.....	154
Wrong Way Alert Limitations.....	290
Wrong Way Alert Precautions.....	290
Wrong Way Alert – Troubleshooting.....	291
Wrong Way Alert – Information Messages.....	291
Wrong Way Alert.....	290
Wrong Way Alert – Troubleshooting.....	291

