

Ford**Kuga**
Owner's handbook

Feel the difference



The information contained in this publication was correct at the time of going to print. In the interest of development the right is reserved to change specifications, design or equipment at any time without notice and without incurring any obligations. This publication, or part thereof, may not be reproduced nor translated without our approval. Errors and omissions excepted.

© Ford Motor Company 2009

All rights reserved.

Part number: AV4J-19A321-DA (CG3542en) 12/2009 20091217135113



Mixed Sources

Product group from well-managed
forests, controlled sources and
recycled wood or fiber

www.fsc.org Cert no. SGS-COC-2452
© 1996 Forest Stewardship Council

Table of contents

Introduction

About this handbook.....	5
Symbols glossary.....	5
Parts and accessories.....	5

Quick start

Quick start.....	8
------------------	---

Child safety

Child seats.....	16
Child seat positioning.....	17
Booster cushions.....	19
ISOFIX anchor points.....	20
Child safety locks.....	21

Occupant protection

Principle of operation.....	22
Fastening the seat belts.....	24
Seat belt height adjustment.....	24
Seat belt reminder.....	24
Using seat belts during pregnancy.....	25
Disabling the passenger airbag.....	25

Keys and remote controls

General information on radio frequencies.....	27
Programming the remote control.....	27
Changing the remote control battery.....	27

Locks

Locking and unlocking.....	29
Keyless entry.....	31
Global opening and closing.....	34

Engine immobiliser

Principle of operation.....	36
Coded keys.....	36
Arming the engine immobiliser.....	36
Disarming the engine immobiliser.....	36

Alarm

Arming the alarm.....	37
Disarming the alarm.....	37

Steering wheel

Adjusting the steering wheel.....	39
Audio control.....	39
Voice control.....	40

Wipers and washers

Windscreen wipers.....	41
Autowipers.....	41
Windscreen washers.....	42
Rear window wiper and washers.....	42
Adjusting the windscreen washer jets.....	43
Headlamp washers.....	43
Checking the wiper blades.....	43
Changing the wiper blades.....	44

Lighting

Lighting control.....	46
Autolamps.....	47
Front fog lamps.....	47
Rear fog lamps.....	47
Headlamp levelling.....	47
Hazard warning flashers.....	48
Adaptive front lighting system (AFS).....	49
Direction indicators.....	50
Interior lamps.....	50
Removing a headlamp.....	51
Changing a bulb.....	52
Bulb specification chart.....	58

Windows and mirrors

Electric windows.....	60
Exterior mirrors.....	61
Electric exterior mirrors.....	62

Table of contents

Auto-dimming mirror.....62

Instruments

Gauges.....63

Warning lamps and indicators.....64

Audible warnings and indicators.....66

Information displays

General information.....68

Personalised settings.....71

Information messages.....73

Climate control

Principle of operation.....80

Air vents.....80

Manual climate control.....81

Automatic climate control.....83

Heated windows and mirrors.....86

Auxiliary heater.....86

Seats

Sitting in the correct position.....90

Head restraints.....90

Manual seats.....91

Electric seats.....93

Rear seats.....94

Heated seats.....94

Convenience features

Sun blinds.....96

Instrument lighting dimmer.....96

Cup holders.....96

Cigar lighter.....97

Auxiliary power sockets.....97

Storage compartments.....98

Glasses holder.....99

Toll reader.....99

CD changer.....99

Auxiliary input (AUX IN) socket.....99

USB port.....100

Floor mats.....100

Starting the engine

General information.....101

Keyless starting.....101

Diesel particulate filter (DPF).....102

Switching off the engine.....103

Fuel and refuelling

Safety precautions.....104

Fuel quality - Petrol.....104

Fuel quality - Diesel.....104

Fuel filler flap.....104

Catalytic converter.....105

Refuelling.....106

Fuel consumption.....106

Technical specifications.....106

Transmission

Manual transmission.....108

Automatic transmission.....108

All-wheel drive (AWD).....111

Brakes

Principle of operation.....112

Hints on driving with ABS.....112

Parking brake.....112

Stability control

Principle of operation.....113

Using stability control.....113

Parking aid

Principle of operation.....115

Using the parking aid.....115

Rear view camera

Principle of operation.....117

Table of contents

Using the rear view camera.....117

Cruise control

Principle of operation.....120

Using cruise control.....120

Load carrying

General information.....122

Luggage anchor points.....122

Luggage covers.....122

Rear under floor storage.....123

Roof racks and load carriers.....124

Towing

Towing a trailer.....127

Detachable tow ball.....127

Driving hints

Running-in.....131

Cold weather precautions.....131

Driving through water.....131

Emergency equipment

First aid kit.....132

Warning triangle.....132

Status after a collision

Fuel cut-off switch.....133

Fuses

Fuse box locations.....134

Changing a fuse.....134

Fuse specification chart.....135

Vehicle recovery

Towing points.....140

Towing the vehicle on four wheels.....140

Maintenance

General information.....142

Opening and closing the bonnet.....142

Engine compartment overview - 2.5L
Duratec (VI5).....144

Engine compartment overview - 2.0L
Duratorq-TDCi (DW) Diesel.....145

Engine oil dipstick - 2.5L Duratec
(VI5).....147

Engine oil dipstick - 2.0L Duratorq-TDCi
(DW) Diesel.....147

Engine oil check.....147

Engine coolant check.....148

Brake and clutch fluid check.....149

Power steering fluid check.....149

Washer fluid check.....149

Technical specifications.....150

Vehicle care

Cleaning the exterior.....152

Cleaning the interior.....152

Repairing minor paint damage.....153

Vehicle battery

Using booster cables.....154

Wheels and tyres

General information.....156

Changing a road wheel.....156

Tyre repair kit.....161

Run flat tyres.....165

Tyre care.....166

Using winter tyres.....166

Using snow chains.....166

Tyre pressure monitoring system.....167

Technical specifications.....168

Vehicle identification

Vehicle identification plate.....170

Vehicle identification number (VIN).....170

Table of contents

Technical specifications

Technical specifications.....171

Telephone

General information.....175

Telephone setup.....175

Bluetooth setup.....176

Telephone controls.....177

Using the telephone - Vehicles Without:
Navigation System.....177

Using the telephone - Vehicles With:
Navigation System.....180

Voice control

Principle of operation.....182

Using voice control.....182

Audio unit commands.....183

Telephone commands.....192

Navigation system commands.....197

Climate control commands.....197

Connectivity

General information.....200

Connecting an external device.....201

Connecting an external device -
Vehicles With: Bluetooth.....201

Using a USB device.....202

Using an iPod.....204

Navigation introduction

Road Safety.....208

Navigation system

Getting started.....209

Appendices

Type approvals.....211

Type approvals.....211

Type approvals.....211

Electromagnetic compatibility.....212

Introduction

ABOUT THIS HANDBOOK

Thank you for choosing Ford. We recommend that you take some time to get to know your vehicle by reading this handbook. The more that you know about it, the greater the safety and pleasure you will get from driving it.

Note: *This handbook describes product features and options available throughout the range, sometimes even before they are generally available. It may describe options not fitted to your vehicle.*

Note: *Some of the illustrations in this handbook may be used for different models, so may appear different to your vehicle. However, the essential information in the illustrations is always correct.*

Note: *Always use and operate your vehicle in line with all applicable laws and regulations.*

Note: *Pass on this handbook when selling your vehicle. It is an integral part of the vehicle.*

This vehicle has received the endorsement of TÜV, the accredited international testing organisation, for its allergy-friendly properties.

All materials used in the manufacture of the interior of this vehicle meet strict requirements of the TÜV TOXPROOF Criteria Catalogue for Vehicle Interiors by TÜV Produkt and Umwelt GmbH and are designed to minimize the risk of allergic reactions.

Additionally an efficient pollen filter protects the passengers against allergen particles in the outdoor air.

For more information, contact TÜV at www.tuv.com.

SYMBOLS GLOSSARY

Symbols in this handbook

WARNING



You risk death or serious injury to yourself and others if you do not follow the instructions highlighted by the warning symbol.

CAUTION



You risk damaging your vehicle if you do not follow the instructions highlighted by the caution symbol.

Symbols on your vehicle



When you see these symbols, read and follow the relevant instructions in this handbook before touching or attempting adjustment of any kind.

PARTS AND ACCESSORIES

Now you can be sure that your Ford parts are Ford parts

Your Ford has been built to the highest standards using high quality Ford Original Parts. As a result, you can enjoy driving it for many years.

Should the unexpected occur and a major part needs replacing, we recommend that you accept nothing less than Ford Original Parts.

Introduction

The use of Ford Original Parts ensures that your vehicle is repaired to its pre-accident condition and maintains its maximum residual value.

Ford Original Parts match Ford's stringent safety requirements and high standards of fit, finish and reliability. Quite simply, they represent the best overall repair value, including parts and labour costs.

Now it is easier to tell if you have really been given Ford Original Parts. The Ford logo is clearly visible on the following parts if they are Ford Original Parts. If your vehicle has to be repaired, look for the clearly visible Ford branding and make sure that only Ford Original Parts have been used.

Look for the Ford logo on the following parts

Sheet metal

- Bonnet
- Doors
- Tailgate

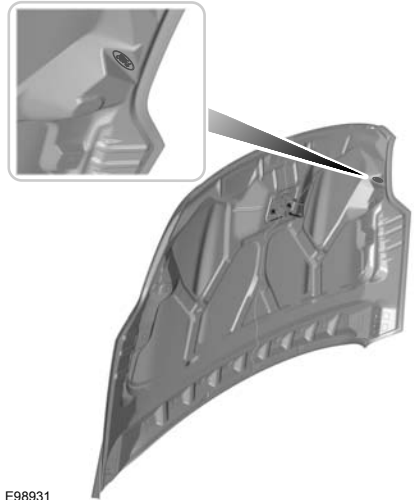

E98931

Bumper, radiator grille, wing and upper tailgate

- Radiator grille
- Front and rear bumper
- Wing
- Upper tailgate

Introduction

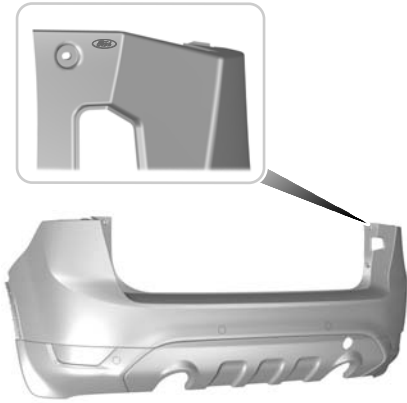

E98917

Exterior mirror



E98918

Glass

- Rear window
- Side glass
- Windscreen



E89939

Lighting

- Rear lamps
- Rear fog lamp
- Headlamp

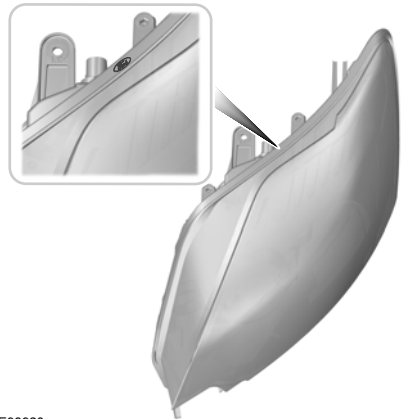

E98920

Quick start

QUICK START

Instrument panel overview

Left-hand drive

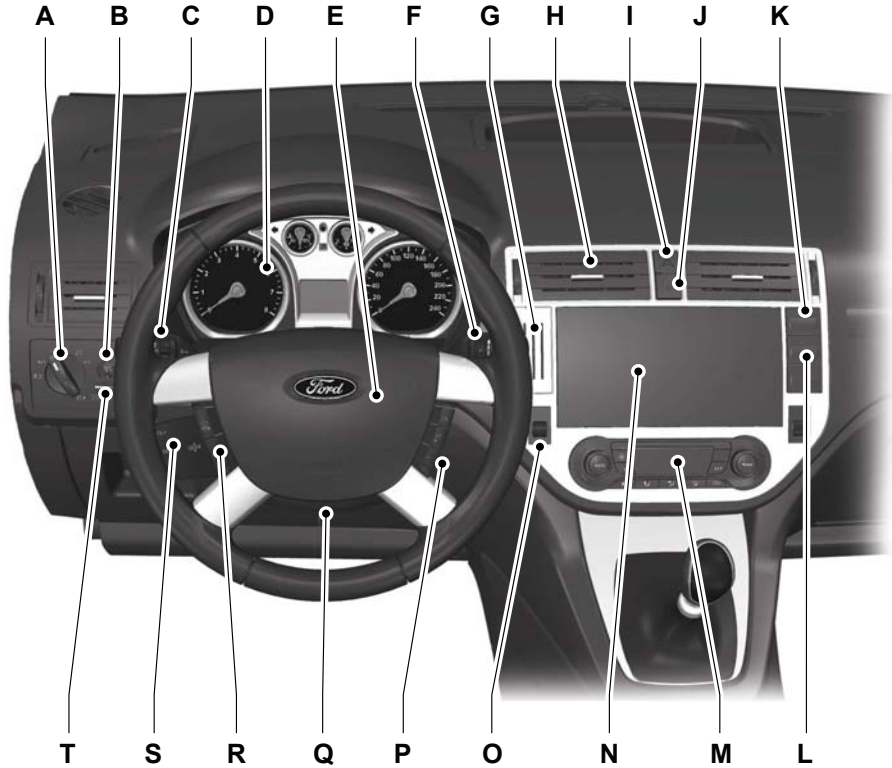

E78209

Quick start

Right-hand drive

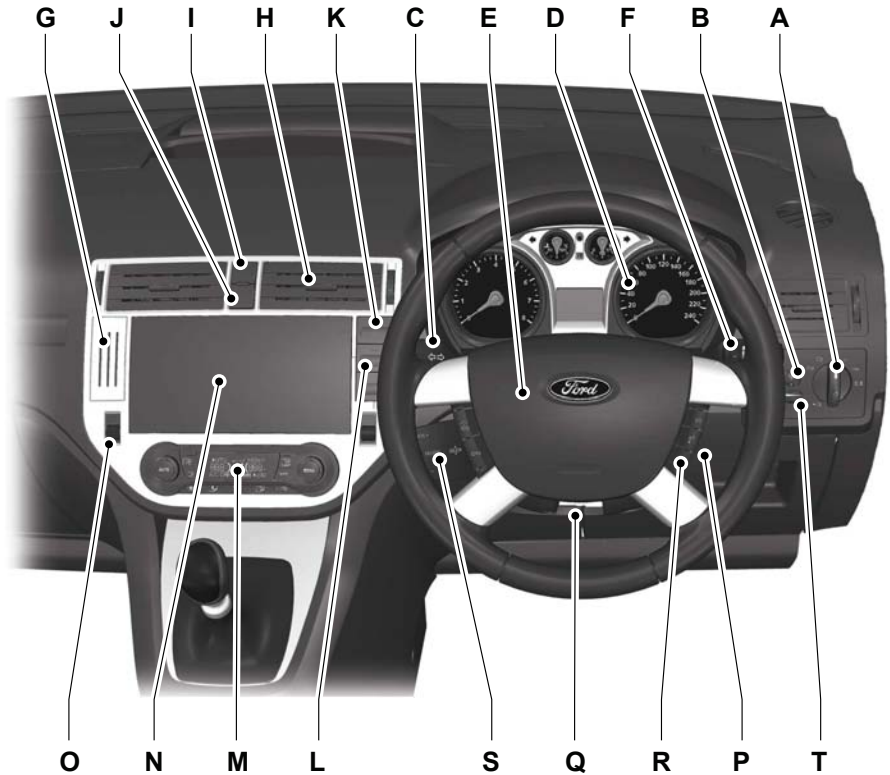

E78210

- A Lighting control. See **Lighting control** (page 46). Front fog lamps. See **Front fog lamps** (page 47). Rear fog lamp. See **Rear fog lamps** (page 47).
- B Headlamp levelling control. See **Headlamp levelling** (page 47).
- C Multi-function lever: Information display controls. Direction indicators. See **Direction indicators** (page 50). Main beam. See **Lighting control** (page 46).
- D Instrument cluster. See **Gauges** (page 63). See **Warning lamps and indicators** (page 64).

Quick start

- E Horn.
- F Wiper lever. See **Wipers and washers** (page 41).
- G Card holder.
- H Air vents. See **Air vents** (page 80).
- I Hazard warning flasher switch. See **Hazard warning flashers** (page 48).
- J Airbag deactivation indicator. See **Disabling the passenger airbag** (page 25). Parking aid switch. See **Using the parking aid** (page 115).
- J Start button. See **Keyless starting** (page 101).
- K Heated windscreen switch. See **Heated windows and mirrors** (page 86).
- L Heated rear window switch. See **Heated windows and mirrors** (page 86).
- M Climate controls. See **Climate control** (page 80).
- N Audio or navigation unit. See separate handbook.
- O Heated front seat switch. See **Heated seats** (page 94).
- P Ignition switch.
- Q Steering wheel adjustment. See **Adjusting the steering wheel** (page 39).
- R Cruise control switches. See **Using cruise control** (page 120).
- S Audio controls. See **Audio control** (page 39).
- T Instrument lighting dimmer. See **Instrument lighting dimmer** (page 96).

Quick start

Locking and unlocking

Unlocking the vehicle

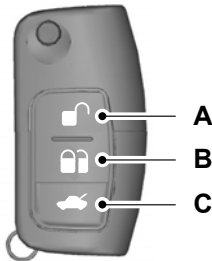

E71963

- A Unlock
- B Lock
- C Tailgate unlock

Press the unlock button once to unlock the vehicle. See **Programming the remote control** (page 27).

Press and hold the unlock button for three seconds to unlock the vehicle and open the windows (global opening)*.

Press the lock button once to activate central locking and arm the alarm.

Press the lock button twice within three seconds to activate double locking and arm the interior sensors.

Press and hold the lock button for three seconds to lock the vehicle and close the windows (global closing)*.

Press the tailgate unlock button twice within three seconds to unlock the luggage compartment.

Press and hold the tailgate unlock button to unlock the upper tailgate.

* only in combination with four electric windows.

Opening the luggage compartment lid

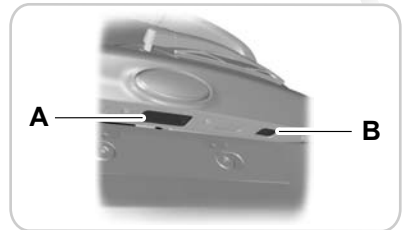

E99409

To open the main luggage compartment lid, press switch **A**. The driver's door must be unlocked.

To open the upper luggage compartment lid, press switch **B**.

See **Locking and unlocking** (page 29).

Quick start

Keyless entry

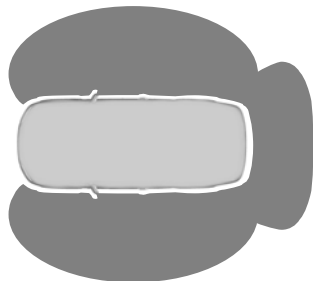

E78276

Passive locking and unlocking requires a valid passive key to be located within one of the three external detection ranges.

Unlocking the vehicle

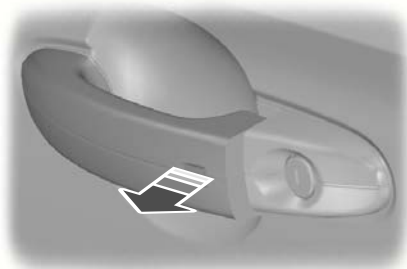

E78278

Pull a door handle to unlock all the doors and the luggage compartment lid and disarm the alarm.

Locking the vehicle

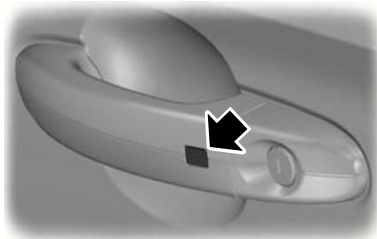

E87384

Locking buttons are located on each of the front doors.

See **Keyless entry** (page 31).

Keyless starting



E85766

Press the start button.

See **Keyless starting** (page 101).

Adjusting the steering wheel

WARNING



Never adjust the steering wheel when the vehicle is moving.

Quick start

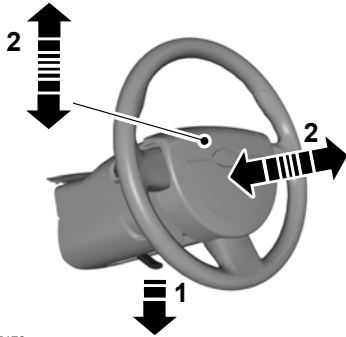

E95178

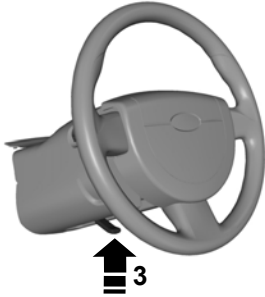

E95179

WARNING



Make sure that you fully engage the locking lever when returning it to its original position.

See **Adjusting the steering wheel** (page 39).

Manual climate control

Defrosting and demisting the windscreen

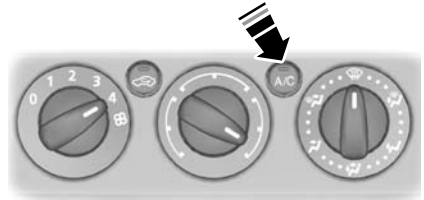

E71382

Rapid heating of vehicle interior



E71377

See **Manual climate control** (page 81).

Quick start

Automatic climate control

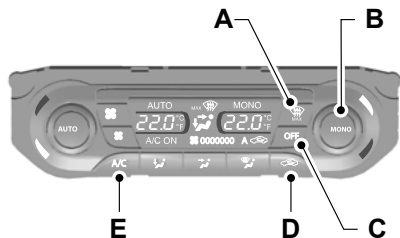

E78730

- A Windscreen defrosting/demisting
- B Toggle mono mode on and off
- C Air conditioning OFF
- D Recirculated air
- E Air conditioning ON

See **Automatic climate control** (page 83).

Autolamps



E73840

The headlamps will come on and go off automatically depending on the ambient light.

See **Lighting control** (page 46).

Direction indicators

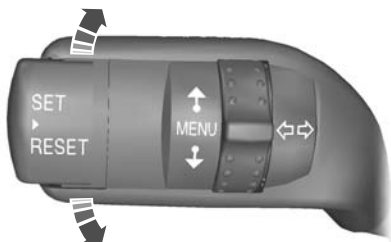

E71098

If the lever is tapped up or down, the direction indicators will flash three times.

See **Direction indicators** (page 50).

Autowipers

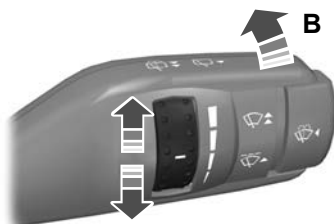

E71014

Move the lever up one position.

The rain sensor will continuously measure the amount of water on the windscreen and adjust the speed of the front wipers automatically.

Adjust the sensitivity of the rain sensor using the rotary control.

See **Windscreen wipers** (page 41).

Quick start

Airbag



E69213

WARNING



To avoid the risk of death or serious injury, never use a rearward facing child restraint in the front, unless the air bag is off.

See **Child safety** (page 16).

See **Disabling the passenger airbag** (page 25).

Manual transmission

Reverse gear – 6-speed transmission

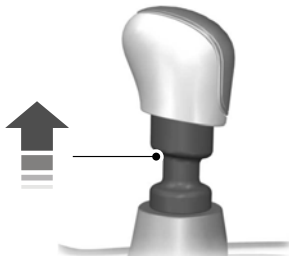

E99067

See **Manual transmission** (page 108).

Towing the vehicle on four wheels

CAUTION



For certain engine and transmission combinations, it is recommended not to tow the vehicle with the drive wheels on the ground.

See **Towing the vehicle on four wheels** (page 140).







Child safety

CHILD SEATS



E68916

WARNINGS

-  Secure children that are less than 150 centimetres tall or less than 12 years of age in a suitable, approved child restraint, in the rear seat.
-  Original text according to ECE R94.01: Extreme Hazard! Do not use a rearward facing child restraint on a seat protected by an air bag in front of it!
-  Read and follow the manufacturer's instructions when you are fitting a child restraint.
-  Do not modify child restraints in any way.
-  Do not hold a child on your lap when the vehicle is moving.
-  Do not leave unattended children in your vehicle.
-  If your vehicle has been involved in an accident, have the child restraints checked by properly trained technicians.

Note: *Mandatory use of child restraints varies from country to country.*

Only child restraints certified to ECE-R44.03 (or later) have been tested and approved for use in your vehicle. A choice of these are available from your Dealer.

Child restraints for different mass groups

Use the correct child restraint as follows:

Baby safety seat



E68918

Secure children that weigh less than 13 kilograms in a rearward facing baby safety seat (Group 0+) in the rear seat.

Child safety

Child safety seat



E68920

Secure children that weigh between 13 and 18 kilograms in a child safety seat (Group 1) in the rear seat.

CHILD SEAT POSITIONING

Vehicles with under floor storage

WARNINGS

 When you are using a child seat with a support leg, make sure that you install the foam spacer correctly inside the storage compartment and that you position the cover correctly.

WARNINGS

 If the foam spacer is damaged or missing, remove the storage compartment cover and extend the leg to the base of the compartment.

All vehicles

WARNING

 When fitting a child seat using the vehicle seat belts make sure the belts are not slack.

CAUTION

 When using a child seat on a rear seat, make sure that the child seat rests tightly against the vehicle seat. It may be necessary to lift or remove the head restraint. See **Head restraints** (page 90).

Note: When using a child seat on a front seat, it may prove difficult to tighten the lap section of the seat belt without slack remaining. If this is the case, adjust the seatback to the fully upright position and raise the height of the seat. See **Seats** (page 90).

Seating positions	Mass group categories				
	0	0+	I	II	III
	Up to 10 kg	Up to 13 kg	9 - 18 kg	15 - 25 kg	22 - 36 kg
Front passenger seat with airbag ON	X	X	UF ¹	UF ¹	UF ¹
Front passenger seat with airbag OFF	U ¹	U ¹	U ¹	U ¹	U ¹

Child safety

Seating positions	Mass group categories				
	O	O+	I	II	III
	Up to 10 kg	Up to 13 kg	9 - 18 kg	15 - 25 kg	22 - 36 kg
Rear seats	U	U	U	U	U

X Not suitable for children in this mass group.

U Suitable for universal category child seats approved for use in this mass group.

U¹ Suitable for universal category child seats approved for use in this mass group. However, we recommend that you secure children in a government approved child seat, in the rear seat.

UF¹ Suitable for universal category forward facing child seats approved for use in this mass group. However, we recommend that you secure children in a government approved child seat, in the rear seat.

ISOFIX child restraints

ISOFIX positions	Mass group categories		
	O	O+	I
	Up to 10 kg	Up to 13 kg	9 - 18 kg
Rear outboard seats	IL	IL	IL, IUF**
Suitable ISOFIX classes*	E	C, D, E	A, B, B1, C, D

IUF Suitable for universal category ISOFIX child restraints approved for use in this mass group.

IL Suitable for any semi-universal ISOFIX child restraint that is indicated in the child seat manufacturers vehicle list.

* As defined by ECE-R16.







Note: ** When you are purchasing an ISOFIX restraint, make sure that you know the correct mass group and ISOFIX size class for the intended seating locations.

Note: ** Make sure that the top tether mechanism does not interfere with the luggage cover.

Child safety

BOOSTER CUSHIONS

WARNINGS

-  Do not install a booster seat or a booster cushion with only the lap strap of the seat belt.
-  Do not install a booster seat or a booster cushion with a seat belt that is slack or twisted.
-  Do not put the seat belt under your child's arm or behind its back.
-  Do not use pillows, books or towels to boost your child's height.
-  Make sure that your children sit in an upright position.
-  Secure children that weigh more than 15 kilograms but are less than 150 centimetres tall in a booster seat or a booster cushion.

CAUTION

-  When using a child seat on a rear seat, make sure that the child seat rests tightly against the vehicle seat. It may be necessary to lift or remove the head restraint. See **Head restraints** (page 90).

Booster seat (Group 2)



E70710

We recommend that you use a booster seat that combines a cushion with a backrest instead of a booster cushion only. The raised seating position will allow you to position the shoulder strap of the adult seat belt over the centre of your child's shoulder and the lap strap tightly across its hips.

Booster cushion (Group 3)



E68924

Child safety

ISOFIX ANCHOR POINTS

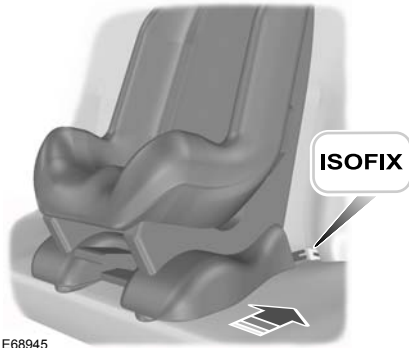

E68945

You can fit ISOFIX child restraints using the ISOFIX anchor points.

Your vehicle is fitted with ISOFIX anchor points that accommodate universally approved ISOFIX child restraints.

The ISOFIX system comprises of two rigid attachment arms on the child restraint that attach to anchor points on the rear seats, where the cushion and backrest meet.

A third anchor point has been provided for child seats that are equipped with a top tether, available for use in the forward facing configuration.

The top tether anchors in your vehicle are located on the floor of the luggage compartment.

The tether strap should be routed beneath the raised rear head restraint, to the anchor point on the floor of the luggage compartment. The anchor point is identified by a pictogram.

After installing the child safety seat, tighten the tether strap according to the manufacturer's instructions.

WARNING

 Use an anti-rotation device when using the ISOFIX system. We recommend that you use a top tether or a support leg.

Attaching a child restraint with a top tether



E78828

WARNING

 Do not attach a tether strap to anything other than the correct tether anchor point.

Route the tether strap to the anchor point. Tighten the tether strap to the manufacturer's instructions.

WARNINGS

 Make sure the top tether strap is not slack or twisted and is properly located on the anchor point.

 Make sure that the seatback is secure and fully engaged in the catch.

Child safety

CHILD SAFETY LOCKS

WARNING



You cannot open the doors from inside if you have put the child safety locks on.



E112197

Left-hand side

Turn anti-clockwise to lock and clockwise to unlock.

Right-hand side

Turn clockwise to lock and anti-clockwise to unlock.

Occupant protection

PRINCIPLE OF OPERATION

Airbags

WARNINGS



Do not modify the front of your vehicle in any way. This could adversely affect deployment of the airbags.



Original text according to ECE R94.01: Extreme Hazard! Do not use a rearward facing child restraint on a seat protected by an airbag in front of it!



Wear a seat belt and keep sufficient distance between yourself and the steering wheel. Only when you use the seat belt properly, can it hold you in a position that allows the airbag to achieve its optimum effect. See **Sitting in the correct position** (page 90).



Have repairs to the steering wheel, steering column, seats, airbags and seat belts carried out by a properly trained technician.



Keep the areas in front of the airbags free from obstruction. Do not affix anything to or over the airbag covers.



Do not poke sharp objects into areas where airbags are fitted. This could damage and adversely affect deployment of the airbags.



Use seat covers designed for seats with side airbags. Have these fitted by a properly trained technician.

Note: You will hear a loud bang and see a cloud of harmless powdery residue if an airbag deploys. This is normal.

Note: Only wipe airbag covers with a damp cloth.

Driver and front passenger airbags

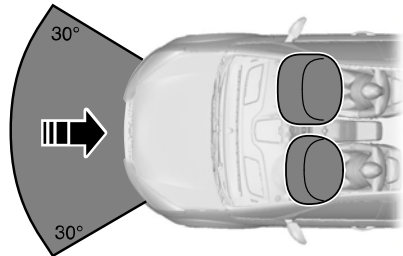

E74302

The driver and front passenger airbags will deploy during significant frontal collisions or collisions that are up to 30 degrees from the left or the right. The airbags will inflate within a few thousandths of a second and deflate on contact with the occupants, thus cushioning forward body movement. During minor frontal collisions, overturns, rear collisions and side collisions, the driver and front passenger airbags will not deploy.

Side airbags



E72658

Side airbags are fitted inside the seatback of the front seats. A label indicates that side airbags are fitted to your vehicle.

Occupant protection

The side airbags will deploy during significant lateral collisions. Only the airbag on the side affected by the collision will deploy. The airbags will inflate within a few thousandths of a second and deflate on contact with the occupants, thus providing protection for the chest and shoulder areas. During minor lateral collisions, overturns, front collisions and rear collisions, the side airbags will not deploy.

Curtain airbags

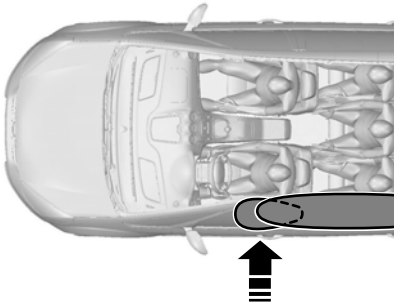

E75004

Curtain airbags are fitted inside the trim panels over the front and rear side windows. Moulded badges in the B-pillar trim panels indicate that curtain airbags are fitted to your vehicle.

The curtain airbags will deploy during significant lateral collisions. Only the airbag on the side affected by the collision will deploy. The airbag will inflate within a few thousandths of a second and deflate on contact with the occupants, thus providing protection for the head. During minor lateral collisions, front collisions, rear collisions, or overturns the curtain airbags will not deploy.

Seat belts

WARNINGS

 Wear a seat belt and keep sufficient distance between yourself and the steering wheel. Only when you use the seat belt properly, can it hold you in a position to achieve its optimum effect. See **Sitting in the correct position** (page 90).

 Never use a seat belt for more than one person.

 Use the correct buckle for each seat belt.

 Do not use a seat belt that is slack or twisted.

 Do not wear thick clothing. The seat belt must fit tightly around your body to achieve its optimum effect.

 Position the shoulder strap of the seat belt over the centre of your shoulder and position the lap strap tightly across your hips.

The driver and front passenger seat belt buckles are fitted with a seat belt pretensioner. Seat belt pretensioners have a lower deployment threshold than the airbags. During minor collisions, it is possible that only the seat belt pretensioners will deploy.

Status after a collision

WARNING

 Seat belts subjected to strain, as a result of an accident, should be renewed and the anchorages checked by a properly trained technician.

Occupant protection

FASTENING THE SEAT BELTS

WARNING



Insert the tongue into the buckle until you hear a distinct click. You have not fastened the seat belt properly if you do not hear a click.



E74124

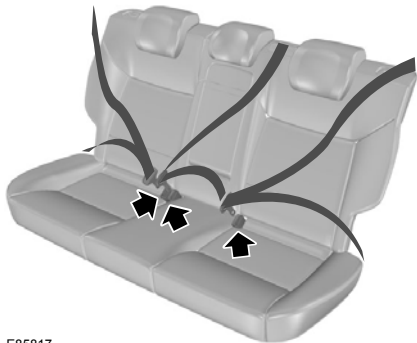

E85817

Pull the belt out steadily. It may lock if you pull it sharply or if the vehicle is on a slope.

Press the red button on the buckle to release the belt. Let it retract completely and smoothly.

SEAT BELT HEIGHT ADJUSTMENT



E87511

Note: *Lifting the slider slightly while pressing the locking button makes it easier to release the locking mechanism.*

To raise or lower, press the locking button on the adjuster and move as necessary.

SEAT BELT REMINDER

WARNING



The occupant protection system will only provide optimum protection when you use the seat belt properly.



The seat belt reminder warning lamp illuminates and an audible warning will sound if the driver's or front seat passenger's seat belt has not been fastened and the vehicle exceeds a relatively low speed. It will also illuminate if the driver's or front seat passenger's seat belt is unfastened when the vehicle is moving. The audible warning will go off after five minutes but the seat belt reminder warning lamp will remain on until the driver's or front seat passenger's seat belt is fastened.

Occupant protection

Deactivating the seat belt reminder

See your dealer.

USING SEAT BELTS DURING PREGNANCY

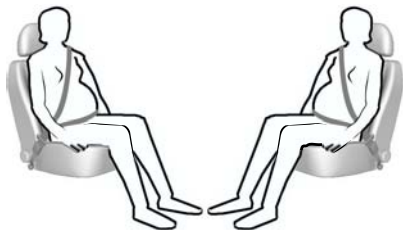

E68587

WARNING

 Position the seat belt correctly for your safety and that of your unborn child. Do not use only the lap strap or the shoulder strap.

Position the lap strap comfortably across your hips and low beneath your pregnant abdomen. Position the shoulder strap between your breasts, above and to the side of your pregnant abdomen.

DISABLING THE PASSENGER AIRBAG

WARNING

 Make sure that the passenger airbag is disabled when using a rearward facing child restraint on the front passenger seat.



E71313

Fitting the passenger airbag deactivation switch

WARNING

 If you need to fit a child restraint on a seat protected by an operational airbag in front of it, have a passenger airbag deactivation switch fitted. Ask your dealer for further information.

Note: The key switch is located in the glove compartment with an airbag deactivation lamp in the instrument panel.

If the airbag warning lamp illuminates or flashes when you are driving, this indicates a malfunction. See **Warning lamps and indicators** (page 64). Remove the child restraint and have the system checked immediately.

Occupant protection

Disabling the passenger airbag

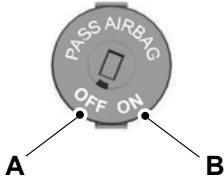

E71312

A Disabled

B Enabled

Turn the switch to position **A**.

When you switch the ignition on, check that the passenger airbag deactivation warning lamp illuminates.

Enabling the passenger airbag

WARNING



Make sure that the passenger airbag is enabled when you are **not** using a child restraint on the front passenger seat.

Turn the switch to position **B**.

Keys and remote controls

GENERAL INFORMATION ON RADIO FREQUENCIES

CAUTION

 The radio frequency used by your remote control can also be used by other short distance radio transmissions (e.g. amateur radios, medical equipment, wireless headphones, remote controls and alarm systems). If the frequencies are jammed, you will not be able to use your remote control. You can lock and unlock the doors with the key.

Note: You could unlock the doors if you press the buttons on the remote control unintentionally.

The operating range between your remote control and your vehicle varies depending on the environment.

PROGRAMMING THE REMOTE CONTROL

You can programme a maximum of eight remote controls to use with your vehicle (including any supplied with your vehicle). Ask your dealer for instructions.

CHANGING THE REMOTE CONTROL BATTERY



Make sure that you dispose of old batteries in an environmentally friendly way.

Seek advice from your local authority regarding recycling.

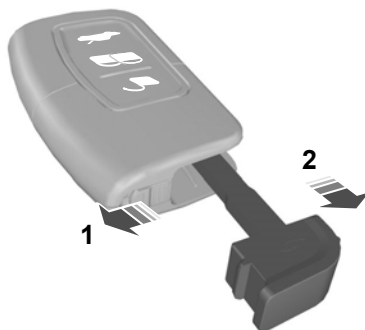

E78284

1. Slide the release slider in the direction of the arrow.
2. Remove the key blade.

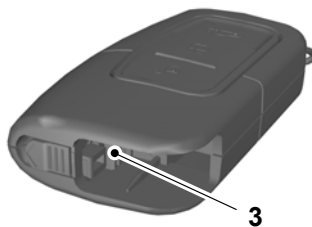

E105064

3. Twist the screwdriver in the position shown to separate the two halves of the remote control.

CAUTION

 Do not touch the battery contacts or the printed circuit board with the screwdriver.

4. Carefully prise out the battery with the screwdriver.
5. Install a new battery (3V CR 2032) with the + facing downwards.
6. Assemble the two halves of the remote control.

Keys and remote controls

7. Install the key blade.

Locks

LOCKING AND UNLOCKING

Central locking

You can only centrally lock the doors if they are all closed.

Note: The driver's door can be unlocked with the key. This needs to be used if the remote control is not functioning.

Double locking

WARNING



Do not activate double locking when persons or animals are inside the vehicle. You will not be able to unlock the doors from the inside if you have double locked them.



E71961

Double locking is a theft protection feature that prevents someone from opening the doors from the inside. You can only double lock the doors if they are all closed.

Locking and unlocking confirmation

When you unlock the doors, the direction indicators will flash once.

When you lock the doors, the direction indicators will flash twice.

Note: The direction indicators will flash twice as soon as you activate central locking. They will not flash again when you press the lock button on the remote control or turn the key for the second time, i.e. when you activate double locking.

Locking and unlocking the doors with the key

Turn the top of the key towards the front of the vehicle to lock the door. Turn the top of the key towards the rear of the vehicle to unlock the door.

Double locking the doors with the key

Turn the key to the lock position twice within three seconds to double lock the doors.

Locking and unlocking the doors and the luggage compartment lid with the remote control

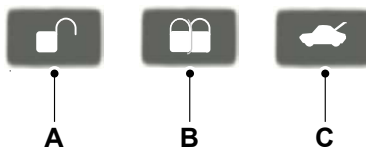

E87379

- A Unlock
- B Lock
- C Luggage compartment lid unlock

Locking the doors and the luggage compartment lid with the remote control

Press button **B** once.

Locks

Double locking the doors and the luggage compartment lid with the remote control

Press button **B** twice within three seconds.

Locking and unlocking the doors from inside

Driver's door

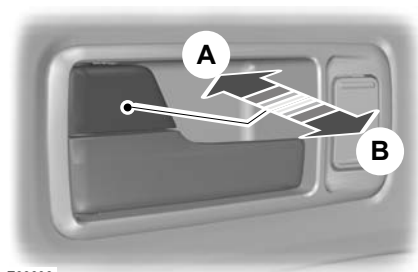

E99606

- A Lock all doors
- B Unlock all doors

Front and rear passenger doors

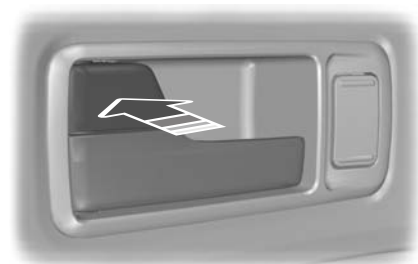

E99607

To lock the front and rear passenger doors individually, press the button and close the door when leaving the vehicle.

Luggage compartment lid

Opening the luggage compartment lid



E99409

- A Main luggage compartment lid
- B Upper luggage compartment lid

Opening the main luggage compartment lid with the remote control

Press button **C** on the remote control twice within three seconds.

Locks

Opening the upper luggage compartment lid with the remote control

Press and hold button **C** on the remote control.

Closing the luggage compartment lid

Upper luggage compartment lid



E99410

Main luggage compartment lid

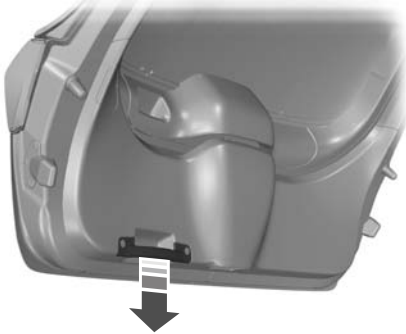

E99470

Automatic relocking

The doors will relock automatically if you do not open a door within 45 seconds of unlocking the doors with the remote control. The door locks and the alarm will return to their previous state.

Reprogramming the unlocking function

If the unlocking function is reprogrammed so that only the driver's door is unlocked (See **Programming the remote control** (page 27).), note the following:

When you press the unlock button either all the doors are unlocked or only the driver's door is unlocked. Pressing the unlock button again unlocks all the doors.

KEYLESS ENTRY

General information

WARNING



The keyless entry system may not function if the key is close to metal objects or electronic devices such as mobile phones.

Note: *If the door handles are pulled repeatedly during a short period of time without the presence of a valid passive key, the system will become inoperable for 30 seconds.*

The passive entry system will not function if:

- The passive key frequencies are jammed.
- The passive key battery is flat.

Note: *If the passive entry system does not function, you will need to use the key blade to lock and unlock your vehicle.*

The keyless system allows the driver to operate the vehicle without the use of a key or remote control.

Locks

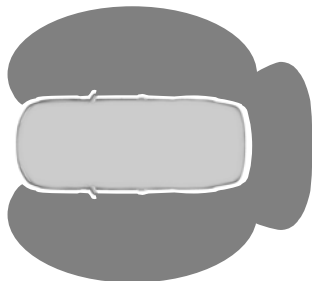

E78276

Passive locking and unlocking requires a valid passive key to be located within one of the three external detection ranges. These are located approximately one and a half metres from the driver and front passenger door handles and the luggage compartment lid.

Passive key

The vehicle can be locked and unlocked with the passive key. The passive key can also be used as a remote control. See **Locking and unlocking** (page 29).

Locking the vehicle

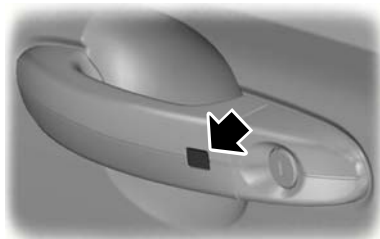

E87384

WARNING



The vehicle does not lock itself automatically. If no locking button is pressed, the vehicle will remain unlocked.

Locking buttons are located on each of the front doors.

To activate central locking and arm the alarm:

- Press a locking button once.

To activate double locking, to arm the alarm and the interior sensors:

- Press a locking button twice within three seconds.

Note: *Once activated, the vehicle will remain locked for approximately three seconds. This is to allow you to pull a door handle and check if the vehicle is locked. When the delay period is over, the doors can be opened again, provided the passive key is within the respective detection range.*

Luggage compartment lid

Note: *The luggage compartment lid cannot be closed and will pop back up if the passive key is located inside the luggage compartment.*

Note: *If a second valid passive key is located within the luggage compartment lid detection range, the luggage compartment lid can be closed.*

Locks

Unlocking the vehicle

Note: *If the vehicle remains locked for longer than three days, the key free system will enter an energy-saving mode. This is to reduce the discharge of the vehicle battery. When the vehicle is unlocked while in this mode, the reaction time of the system may be a little longer than normal. Unlocking the vehicle once will deactivate the energy-saving mode.*

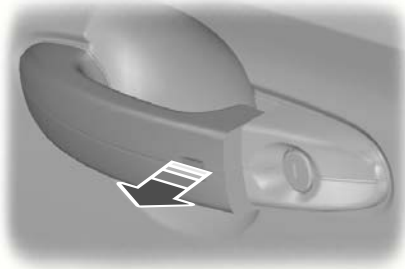

E78278

Pull one of the door handles or the luggage compartment lid handle.

Note: *A valid passive key must be located within the detection range of that door.*

One long flash of the direction indicators confirms that all the doors, the luggage compartment lid and the fuel filler flap have been unlocked and that the alarm has been disarmed.

Unlocking only the driver's door

If the unlocking function is reprogrammed so that only the driver's door is unlocked (See **Programming the remote control** (page 27).), note the following:

If the driver's door is the first door which is opened, the other doors and the luggage compartment lid will remain locked. All the other doors can be unlocked from inside the vehicle by using the unlock button next to the driver's door handle. Doors can be unlocked individually by pulling the interior door handles on those doors.

If the front passenger door or one of the rear doors is the first door which is opened, **all** the doors and the luggage compartment lid will be unlocked.

Disabled keys

Any keys left inside the vehicle interior when it is locked will be disabled.

A disabled key cannot be used to turn the ignition on or start the engine.

In order to use these passive keys again, they have to be enabled.

To enable all your passive keys, unlock the vehicle using a passive key or the remote control unlocking function.

All passive keys will then be enabled if the ignition is turned on or the vehicle is started using a valid key.

Locks

Locking and unlocking the doors with the key blade

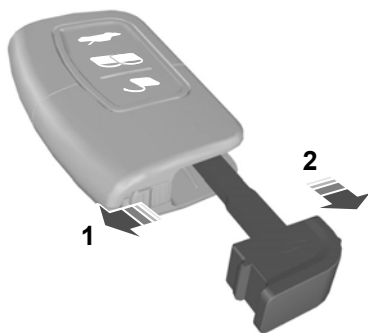

E78284

1. Slide the release slider in the direction of the arrow and pull out the key blade with your thumb.
2. Remove the key blade and insert it into the lock.

GLOBAL OPENING AND CLOSING

You can also operate the electric windows with the ignition off via the global opening and global closing function.

Note: *Global closing will only operate if you have set the memory correctly for each window. See **Electric windows** (page 60).*

Global opening

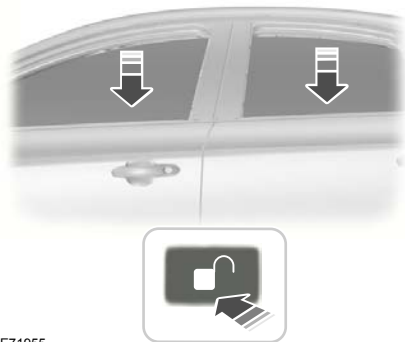

E71955

To open all the windows, press and hold the **unlock** button for at least three seconds. Press either the **lock** or the **unlock** button again to stop the opening function.

Global closing

WARNING



Take care when using global closing. In an emergency, press the button on the driver's door handle to stop.

Note: *Global closing can be activated using the button on the driver's door handle. Global opening and closing can also be activated using the buttons on the passive key.*

Locks

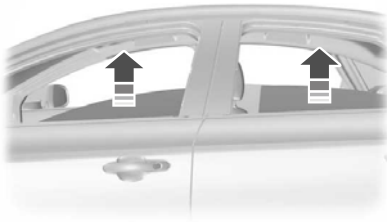

E99679

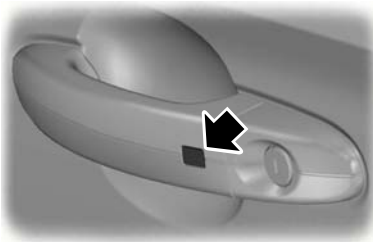

E87384

To close all the windows, press and hold the button on the driver's door handle for at least two seconds. The anti-trap function is also active during global closing.

Engine immobiliser

PRINCIPLE OF OPERATION

The engine immobiliser is a theft protection system that prevents someone from starting the engine with an incorrectly coded key.

CODED KEYS

Note: *Do not shield your keys with metal objects. This may prevent the receiver from recognising your key as a valid one.*

Note: *Have all of your remaining keys erased and recoded if you lose a key. Ask your dealer for further information. Have replacement keys recoded together with your existing keys.*

If you lose a key, you can obtain a replacement from your Ford Dealer. If possible, provide them with the key number from the tag provided with the original keys. You can also obtain additional keys from your Ford Dealer.

ARMING THE ENGINE IMMOBILISER

The engine immobiliser is armed automatically a short time after you have switched the ignition off.

DISARMING THE ENGINE IMMOBILISER

The engine immobiliser is disarmed automatically when you switch the ignition on with a correctly coded key.

The indicator in the instrument cluster will come on for approximately three seconds and then go out. If the indicator stays on for one minute or flashes for approximately one minute and then repeatedly at irregular intervals, your key has not been recognised. Remove the key and try again.

If you are unable to start the engine with a correctly coded key, this indicates a malfunction. Have the immobiliser checked immediately.

Alarm

ARMING THE ALARM

The system is armed as soon as the vehicle is locked and acts as a deterrent to unauthorised persons who attempt to open the doors, bonnet or luggage compartment, or remove the audio system.

The alarm sounds for 30 seconds if an unauthorised person opens a door, the luggage compartment or the bonnet. The hazard flasher lights will flash for five minutes.

Any attempt to start the engine without a valid key or to remove the audio system sounds the alarm again.

Automatic arming delay

The 20 seconds arming delay begins when the bonnet, luggage compartment and all doors are closed.

Interior sensors



E71401

WARNING



This system functions correctly only if all windows are completely closed.

In addition to this, the sensors located in the interior lamp unit must not be covered up. The system should not be activated if any persons, animals or other moving objects are inside the vehicle.

This system acts as a deterrent against unauthorised intrusion by sensing any movement within the vehicle.

Unauthorised entry into the vehicle's interior will trigger the alarm in the same way as the anti-theft system.

The sensors are located in the interior lamp unit.

All except Britain and Ireland

The interior sensing alarm is armed together with the double locking system.

Britain and Ireland only

The interior sensing alarm is armed together with the central locking system.

To deactivate the interior sensors press the switch next to the driver's door handle.

DISARMING THE ALARM

The system can be deactivated at any time, even when the alarm is sounding, by unlocking the vehicle from the outside.

The system will be deactivated if:

- A valid passive key is located within the detection range.
- The unlock button on the remote control is pressed.
- A valid passive key is located within the vehicle interior and you depress the clutch pedal (manual transmission) or brake pedal (automatic transmission).
- You insert the key blade into the key holder.

The system for the luggage compartment lid will be deactivated if:

- A valid passive key is located within the detection range.
- The luggage compartment lid unlock button on the remote control is pressed.

Alarm

Britain and Ireland only

If the vehicle is unlocked using the key blade, a 12 second delay chime starts as soon as the driver's door is opened. The alarm will be deactivated during this period.

Steering wheel

ADJUSTING THE STEERING WHEEL

WARNING

 Never adjust the steering wheel when the vehicle is moving.

Note: Make sure that you are sitting in the correct position. See **Sitting in the correct position** (page 90).

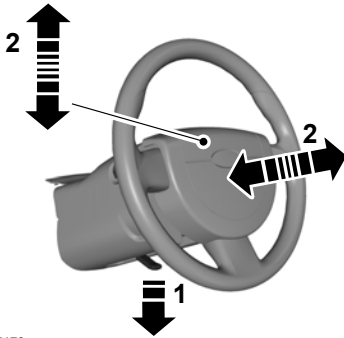

E95178



E95179

WARNING

 Make sure that you fully engage the locking lever when returning it to its original position.

AUDIO CONTROL

Select radio, CD or cassette mode on the audio unit.

The following functions can be operated with the remote control:

Volume

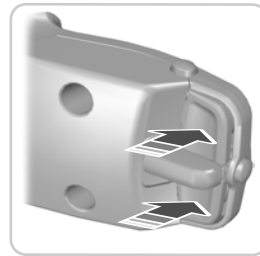

E78046

Volume up: Press the top button on the back of the remote control.

Volume down: Press the bottom button on the back of the remote control.

Steering wheel

Seek

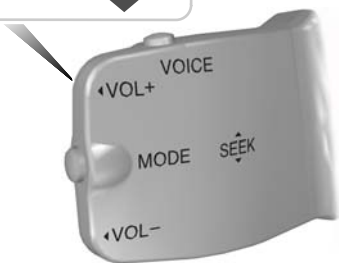
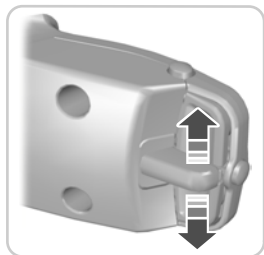

E78047

Move the lever up or down:

- In **radio mode**, this will locate the next radio station up or down the frequency band.
- In **CD mode**, it will select the next or previous track.

Mode



E78048

Briefly press the button on the side:

- In **radio mode**, this will locate the next pre-set radio station.
- In **CD mode**, this will select the next CD if a CD changer is fitted.
- In **all modes** to abort a traffic message during broadcasting.

Press and hold the button on the side:

- In **radio mode** to change the waveband.

VOICE CONTROL



E78049

To select or deselect voice control, press the button on the top.

For further information See **Voice control** (page 182).

Wipers and washers

WINDSCREEN WIPERS

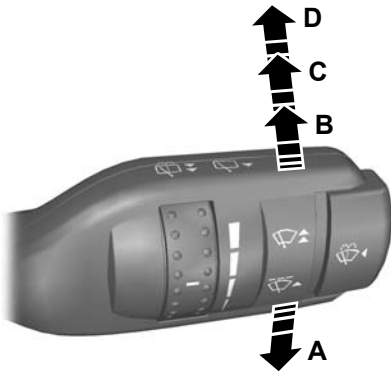

E71012

- A Single wipe
- B Intermittent wipe or autowipers
- C Normal wipe
- D High speed wipe

Intermittent wipe

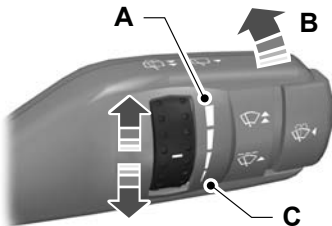

E71013

- A Long wipe interval
- B Intermittent wipe
- C Short wipe interval

Automatic wiper system

Some models without autowipers are fitted with a speed-dependent front screen wiper system.

When the vehicle is slowed to walking speed or is brought to a standstill, the wiper speed will automatically switch to the next lower wiper speed setting.

When the vehicle speed is increased, the wiper speed will return to the manually-chosen setting.

Moving the wiper lever when the system is operating will switch off the system.

If the vehicle is again slowed to walking speed or is brought to a standstill, the system is reactivated.

AUTOWIPERS

CAUTIONS

- ⚠ Do not switch autowipers on in dry weather conditions. The rain sensor is very sensitive and the wipers may operate if dirt, mist or flies hit the windscreen.
- ⚠ Replace the wiper blades as soon as they begin to leave bands of water and smears. If you do not replace them, the rain sensor will continue to detect water on the windscreen and the wipers will operate, even though the majority of the windscreen is dry.
- ⚠ Fully defrost the windscreen in icy conditions before you switch autowipers on.
- ⚠ Switch autowipers off before you enter a car wash.

Wipers and washers

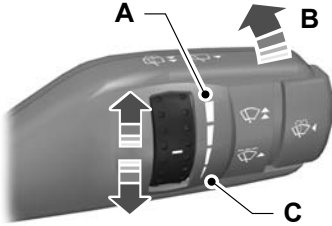

E71013

- A Low sensitivity
- B On
- C High sensitivity

If you switch autowipers on, the wipers will not cycle until water is detected on the windscreen. The rain sensor will then continuously measure the amount of water on the windscreen and adjust the speed of the wipers automatically.

Adjust the sensitivity of the rain sensor using the rotary control. With low sensitivity, the wipers will operate when the sensor detects a lot of water on the windscreen. With high sensitivity, the wipers will operate if the sensor detects a small amount of water on the windscreen.

WINDSCREEN WASHERS



E71016

WARNING



Do not operate the washer for more than 10 seconds at a time, and never when the reservoir is empty.

While the button at the end of the lever is pressed the washer will work in conjunction with the wipers.

After releasing the button, the wipers operate for a short time.

REAR WINDOW WIPER AND WASHERS

Intermittent wipe



E71017

Pull the lever towards the steering wheel.

Reverse gear wipe

The rear wiper will be activated automatically when selecting reverse gear if:

- the rear wiper is not already switched on,
- the wiper lever is in position **A**, **B**, **C** or **D** and
- the front wiper is operating (when set to position **B**).

The rear wiper will follow the front wiper interval (at intermittent or normal speed).

Wipers and washers

Rear window washer



E71018

WARNING



Do not operate the washer for more than 10 seconds at a time, and never when the reservoir is empty.

While the lever is pulled towards the steering wheel the washer will work in conjunction with the wipers.

Once the wash and wipe cycle is completed, the wipers will pause and then perform one more wipe to clear the windscreen.

After releasing the lever, the wipers operate for a short time.

ADJUSTING THE WINDSCREEN WASHER JETS

1. Open the bonnet. See **Opening and closing the bonnet** (page 142).

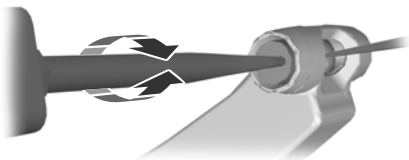

E99777

2. Using a suitable implement adjust the jets.
3. Close the bonnet and check the operation of the jets. See **Opening and closing the bonnet** (page 142).

HEADLAMP WASHERS

The headlamp washers will operate with the windscreen washers when the headlamps are on.

Note: *To stop the washer fluid reservoir emptying quickly, the headlamp washers will not operate every time that you use the windscreen washers.*

CHECKING THE WIPER BLADES

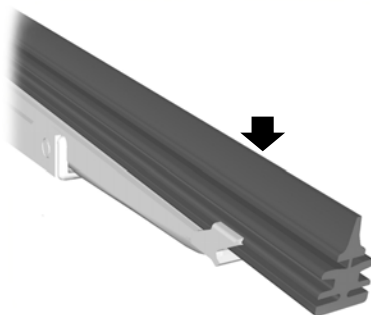

E66644

Run the tip of your fingers over the edge of the blade to check for roughness.

Clean the wiper blade lips with water applied with a soft sponge.

Wipers and washers

CHANGING THE WIPER BLADES

Windscreen wiper blades

CAUTIONS

- ❗ Set the windscreen wipers in the service position to change the wiper blades.
- ❗ You can use the service position in winter to provide easier access to the wiper blades for freeing them from snow and ice. The windscreen wipers will return to their normal position as soon as you switch on the ignition so make sure that the outside of the windscreen is free from snow and ice before you switch on the ignition.

Service position



E85833

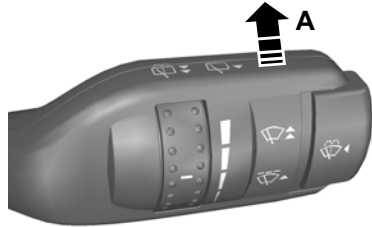

E99280

1. Turn on the ignition.
2. Move the wiper lever to position **A** and turn the ignition off as soon as the wiper blades have reached the service position.

Changing the windscreen wiper blades

Set the windscreen wipers in the service position and lift the wiper arms.

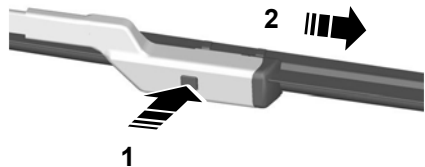

E72899

1. Press the locking button.
2. Remove the wiper blade.

Note: Make sure that the wiper blade locks into place.

3. Install in the reverse order.

Wipers and washers

Rear window wiper blade

1. Lift the wiper arm.

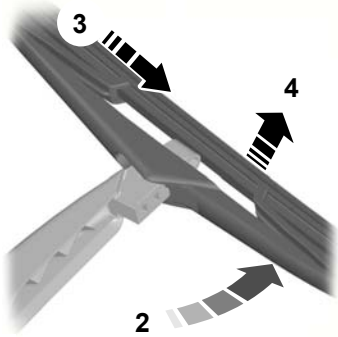

E86456

2. Position the wiper blade at right angles to the wiper arm.
3. Disengage the wiper blade from the wiper arm.
4. Remove the wiper blade.

Note: Make sure that the wiper blade locks into place.

5. Install in the reverse order.

Lighting

LIGHTING CONTROL

Lighting control positions

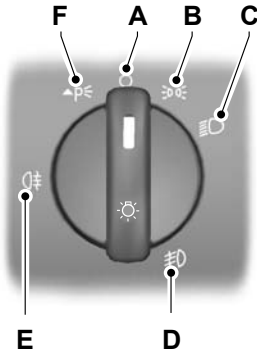

E71094

- A Off
- B Side and tail lamps
- C Headlamps
- D Front fog lamps
- E Rear fog lamps
- F Parking lamps

Parking lamps

CAUTION

 Prolonged use of the parking lamps will discharge the battery.

Switch off the ignition.

Push the lighting control inwards and turn it to position **F**.

Main and dipped beam



E71095

Pull the lever fully towards the steering wheel to switch between main and dipped beam.

Headlamp flasher

Pull the lever slightly towards the steering wheel.

Home safe lighting

Switch the ignition off and pull the direction indicator lever towards the steering wheel to switch the headlamps on. You will hear a short tone. The headlamps will go off automatically after 3 minutes with any door open, or 30 seconds after the last door has been closed.

With all doors closed, but within the 30 second delay, opening any door will result in the 3 minute timer starting again.

The home safe lights can be cancelled by either pulling the direction indicator lever towards the steering wheel again or by turning the ignition switch ON.

Lighting

AUTOLAMPS



E73840

Note: If you have switched autolamps on, you can only switch the main beam on when autolamps has switched the headlamps on.

The headlamps will come on and go off automatically depending on the ambient light.

FRONT FOG LAMPS



E71096

WARNING



Only use the front fog lamps when visibility is considerably restricted by fog, snow or rain.

Note: You cannot switch the front fog lamps on if you have switched autolamps on.

REAR FOG LAMPS



E71097

WARNING



Do not use the rear fog lamps when it is raining or snowing and visibility is more than 50 metres.

Note: You cannot switch the rear fog lamps on if you have switched autolamps on.

HEADLAMP LEVELLING

Note: Vehicles with Xenon headlamps are equipped with automatic headlamp levelling.

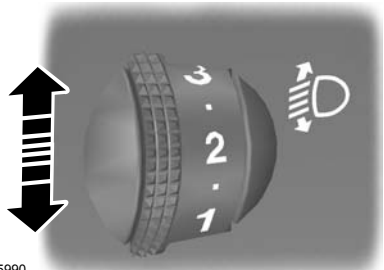

E65990

Lighting

You can adjust the level of the headlamp beams according to the vehicle load.

Recommended headlamp levelling control positions

Load		Load in luggage compartment ¹	Control position
Front seats	Rear seats		
1-2	-	-	0
1-2	3	-	1
1-2	3	Max	1.5
1	-	Max	3

¹ See **Vehicle identification plate** (page 170).

HAZARD WARNING FLASHERS

Note: Depending on applicable laws and regulations in the country for which your vehicle was originally built, the hazard warning flashers may flash if you brake heavily.



For item location: See **Quick start** (page 8).

Lighting

ADAPTIVE FRONT LIGHTING SYSTEM (AFS)

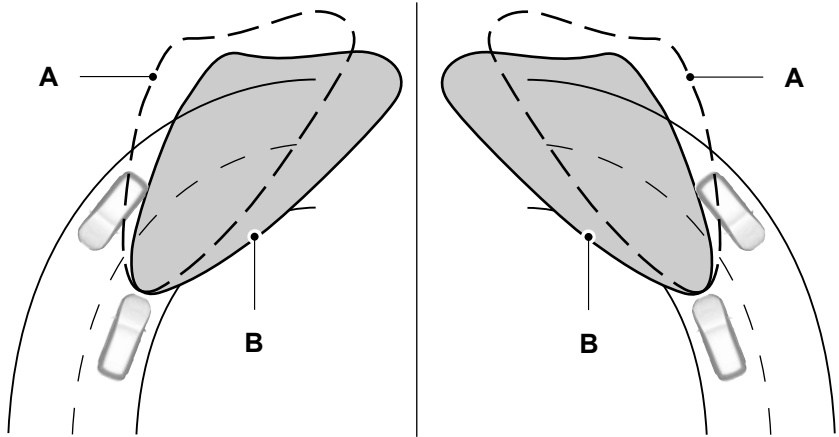

E72897

- A without AFS
- B with AFS

The AFS adjusts the headlamp dipped beam depending on vehicle direction and speed. It improves visibility when you are driving at night and helps to reduce headlamp glare for oncoming drivers.

The headlamps will also move when the vehicle is stationary and the steering wheel is turned. To prevent headlamp glare for the oncoming traffic, they will only move towards the passenger side of the vehicle.

The system will not operate when you have switched on the daytime running lamps or when you have selected reverse gear.

To activate the AFS when the daytime running lamps are activated, turn the lighting control to position **C**. See **Lighting control** (page 46).

A message will appear in the information display and the headlamp indicator flashes if the system malfunctions. See **Information messages** (page 73).

The headlamps will move to a fixed central or dipped position. Have the system checked as soon as possible.

Lighting

DIRECTION INDICATORS

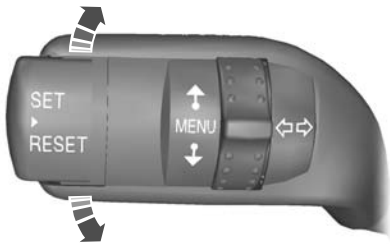

E71098

Note: Tap the lever up or down to make the direction indicators flash only three times.

INTERIOR LAMPS

Courtesy lamp

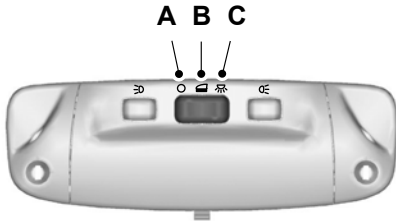

E71945

- A Off
- B Door contact
- C On

If you set the switch to position **B**, the courtesy lamp will come on when you unlock or open a door or the luggage compartment lid. If you leave a door open with the ignition switch off, the courtesy lamp will go off automatically after some time to prevent the vehicle battery from discharging. To switch it back on, switch on the ignition for a short time.

The courtesy lamp will also come on when you switch off the ignition. It will go off automatically after a short time or when you start or restart the engine.

If you set the switch to position **C** with the ignition switch off, the courtesy lamp will come on. It will go off automatically after a short time to prevent the vehicle battery from discharging. To switch it back on, switch on the ignition for a short time.

Reading lamps

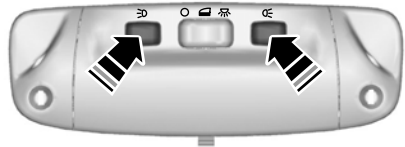

E71946

If you switch off the ignition, the reading lamps will go off automatically after some time to prevent the vehicle battery from discharging. To switch them back on, switch on the ignition for a short time.

Lighting

Vanity mirror lamps

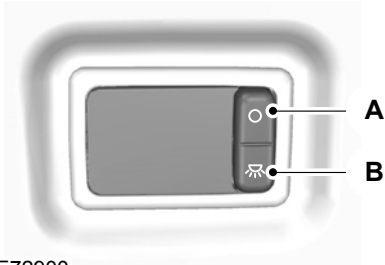

E72900

- A Off
- B On

If you switch off the ignition, the vanity mirror lamps will go off automatically after a short time to prevent the vehicle battery from discharging. To switch them back on, switch on the ignition for a short time.

REMOVING A HEADLAMP

WARNING



Have Xenon bulbs changed by a trained technician. There is a risk of electric shock.

1. Open the bonnet. See **Opening and closing the bonnet** (page 142).

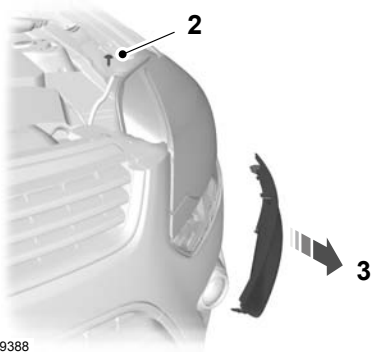

E99388

2. Remove the screw.
3. Using a suitable implement, remove the trim panel.

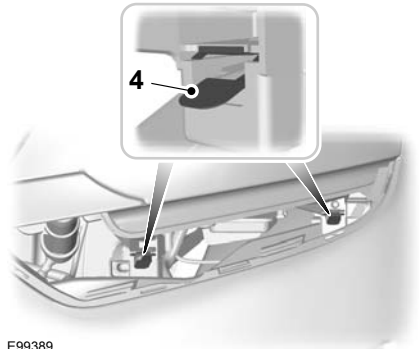

E99389

4. Release the retaining clips.

Lighting

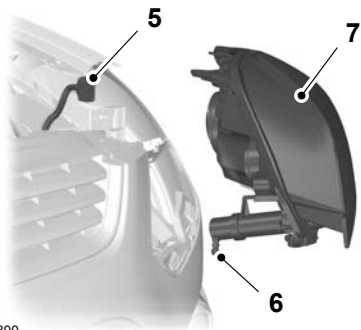

E99390

5. Disconnect the electrical connector.
6. Disconnect the headlamp washer hose.
7. Remove the headlamp.

Note: When fitting the headlamp, make sure that you fully engage the headlamp in the retaining clips.

CHANGING A BULB

WARNINGS



Switch the lights and the ignition off.



Let the bulb cool down before removing it.



Have Xenon bulbs changed by a trained technician. There is a risk of electric shock.

CAUTIONS



Do not touch the glass of the bulb.



Only fit bulbs of the correct specification. See **Bulb specification chart** (page 58).

Headlamp

Direction indicator

1. Remove the headlamp. See **Removing a headlamp** (page 51).

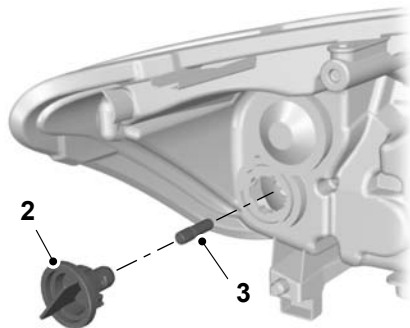

E99482

2. Turn the bulb holder anti-clockwise and remove it.
3. Gently press the bulb into the bulb holder, turn it anti-clockwise and remove it.

Headlamp main and dipped beam

Note: Remove the covers to gain access to the bulbs.

1. Remove the headlamp. See **Removing a headlamp** (page 51).

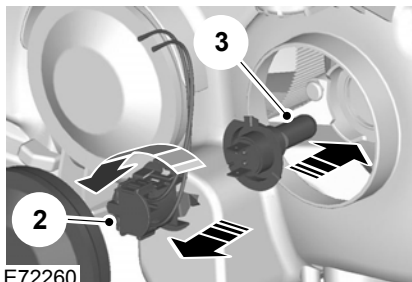

E72260

Lighting

2. Turn the bulb holder anti-clockwise and remove it.
3. Remove the bulb.

Side lamp

1. Remove the headlamp. See **Removing a headlamp** (page 51).

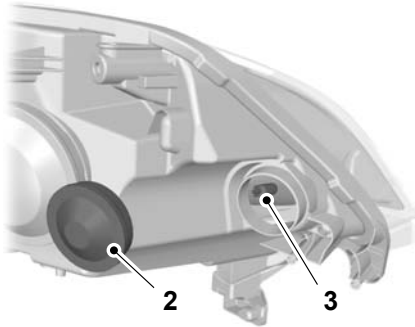

E99437

2. Remove the cover.
3. Pull the bulb holder and remove it. Remove the bulb.

Side repeaters



E99397

1. Remove the cover.

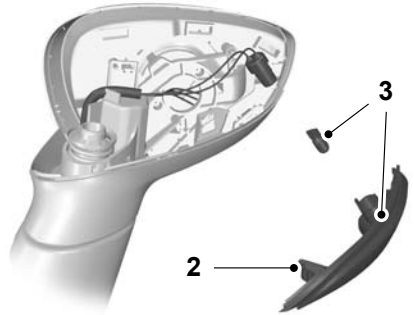

E99398

2. Release the retaining clip.
3. Remove the bulb and bulb holder. Remove the bulb.

Approach lamp



E72264

Note: Position the mirror glass as far inwards as possible.

1. Insert a screwdriver into the gap between the mirror housing and the mirror glass and release the metal retaining clip.

Lighting

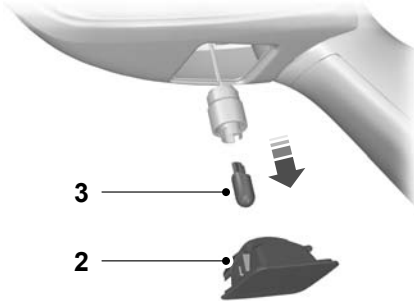

E72265

2. Remove the lamp.
3. Remove the bulb.

Front fog lamps

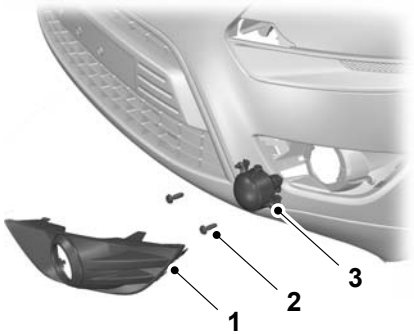

E99405

Note: You cannot separate the fog lamp bulb from the bulb holder.

1. Using a suitable implement, remove the cover.
2. Remove the screws.
3. Remove the lamp.

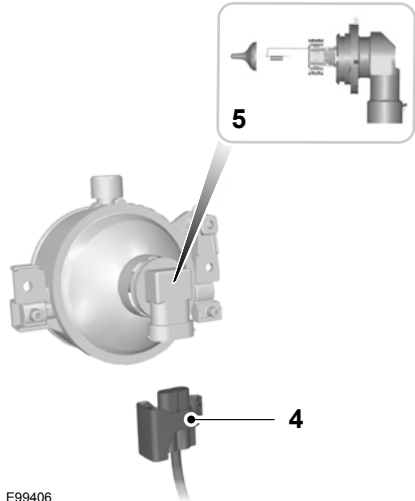

E99406

4. Disconnect the electrical connector.
5. Turn the bulb holder anti-clockwise and remove it.

Rear fog lamps

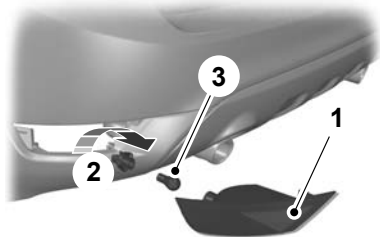

E107752

1. Carefully remove the lamp.
2. Turn the bulb holder anti-clockwise and remove it.
3. Remove the bulb.

Lighting

Rear lamps

Direction indicator and reverse lamp



E99407

1. Remove the trim panel.

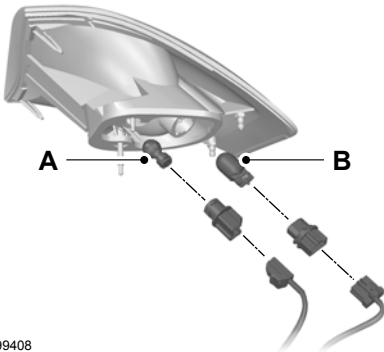

E99408

- A Direction indicator
- B Reverse lamp

2. Disconnect the electrical connector.
3. Turn the bulb holder anti-clockwise and remove it.
4. Remove the bulb.

Tail lamp and brake lamp

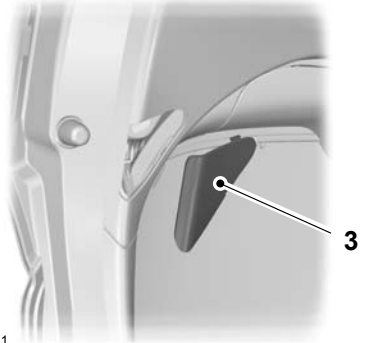

E99411

1. Remove the trim panel.



E99412

2. Remove the nut.

Lighting

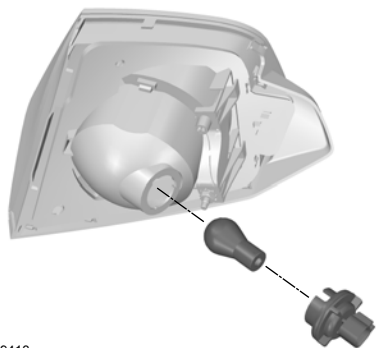

E99413

3. Gently press the bulb into the bulb holder, turn it anti-clockwise and remove it.

Central high mounted brake lamp

Note: The LED board is not a serviceable item, please consult your dealer if this fails.

Number plate lamp

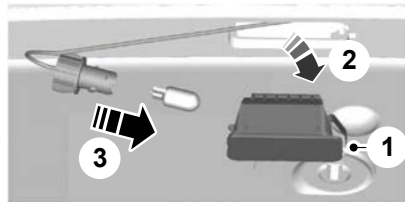

E72789

1. Carefully release the spring clip.
2. Remove the lamp.
3. Remove the bulb.

Interior lamp

Vehicles without interior sensors

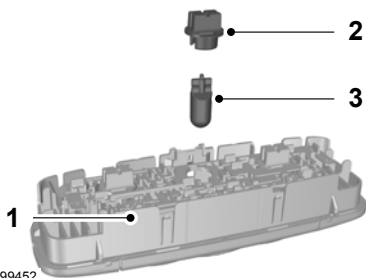

E99452

1. Carefully prise out the lamp.
2. Turn the bulb holder anti-clockwise and remove it.
3. Remove the bulb.

Vehicles with interior sensors

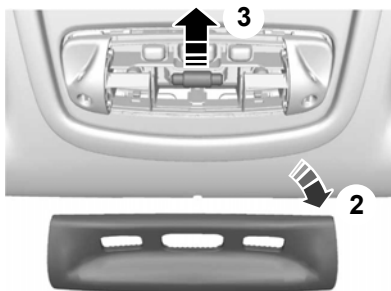

E72787

1. Carefully prise out the lens.
2. Remove the lens.
3. Remove the bulb.

Lighting

Reading lamps

Vehicles without interior sensors

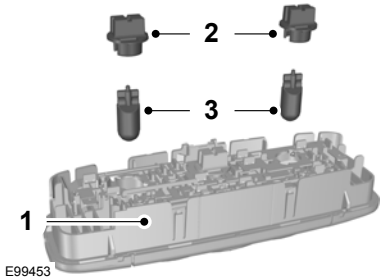

1. Carefully prise out the lamp.
2. Turn the bulb holder anti-clockwise and remove it.
3. Remove the bulb.

Vehicles with interior sensors

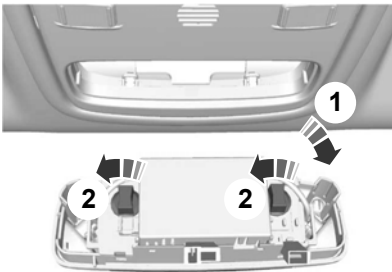

1. Carefully prise out the lamp.
2. Turn the bulb holder anti-clockwise and remove it.



3. Remove the bulb.

Vanity mirror lamp

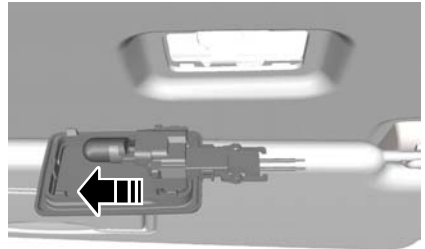

1. Carefully prise out the lamp.
2. Remove the bulb.

Lighting

Luggage compartment lamp

1. Carefully prise out the lamp.
2. Remove the bulb.

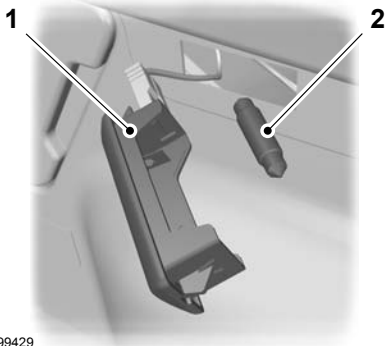

E99429

BULB SPECIFICATION CHART

Lamp	Specification	Power (watt)
Front direction indicator	H21W	21
Headlamp main beam	H7	55
Headlamp dipped beam	H7	55
Side repeater	W5W	5
Front fog lamp	H8	35
Side lamp	W5W	5
Rear direction indicator	PSY19W	19
Brake and tail lamp	W21/5W	21/5
Rear fog lamp	P21W	21
Reversing lamp	P21W	21
Central high mounted brake lamp	1 x LED board	1.4
Number plate lamp	W5W	5
Interior lamp	W6W	6
Reading lamp	W5W	5
Vanity mirror lamp	W5W	5

Lighting

Lamp	Specification	Power (watt)
Luggage compartment lamp	Festoon	10

Windows and mirrors

ELECTRIC WINDOWS

WARNING



Do not operate the electric windows unless they are free from obstruction.

Note: *If you operate the switches often during a short period of time, the system might become inoperable for a certain time to prevent damage due to overheating.*

Switch on the ignition to operate the electric windows.

Global opening and closing

You can also operate the electric windows with the ignition off via the global opening and closing function. See **Locks** (page 29).

Driver's door switches

You can operate all the windows with the switches on the door trim panel of the driver's door.



E70848

Opening and closing the windows automatically

Press or lift the switch to the second action point and release it completely. Press or lift it again to stop the windows.

Safety switch for rear windows

Note: *You can always operate the rear windows from the driver's door.*



E70850

A switch in the driver's door disables the rear electric window switches.

The light in the switch comes on and the lights in the rear window switches go off when the rear windows are disabled.

Anti-trap function

WARNING



Careless closing of the windows can override the protection function and cause injuries.

The electric windows will stop automatically while closing and reverse some distance if there is an obstacle in the way.

Windows and mirrors

Overriding the anti-trap function

CAUTION



While you close the window for the third time, the anti-trap function is disabled. Make sure there are no obstacles in the way of the closing window.

To override this protection function when there is a resistance, e.g. in the winter, proceed as follows:

1. Close the window twice until it reaches the resistance and let it reverse.
2. Close the window a third time to the resistance. The anti-trap function is disabled and you cannot close the window automatically. The window will override the resistance and you can close it fully.
3. If the window does not close after the third attempt, have it checked by an expert.

Resetting the memory of the electric windows

WARNING



The anti-trap function is deactivated until you have reset the memory.

After the battery has been disconnected from the vehicle you must reset the memory separately for each window:

1. Lift and hold the switch until the window is fully closed.
2. Release the switch.
3. Lift the switch again for one more second.
4. Push and hold the switch until the window is fully open.
5. Release the switch.

6. Lift and hold the switch until the window is fully closed.
7. Open the window and try to close it automatically.
8. Reset and repeat procedure if the window does not close automatically.

EXTERIOR MIRRORS

WARNING



Do not overestimate the distance of the objects that you see in the convex mirror. Objects seen in convex mirrors will appear smaller and further away than they actually are.

Manual folding mirrors

Folding

Push the mirror towards the door window glass.

Unfolding

Make sure that you fully engage the mirror in its support when returning it to its original position.

Windows and mirrors

ELECTRIC EXTERIOR MIRRORS

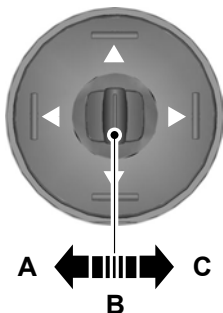

E70846

- A Left-hand mirror
- B Off
- C Right-hand mirror

Mirror tilting positions

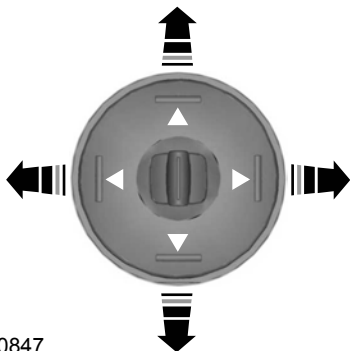

E70847

The electric exterior mirrors are fitted with a heating element that will defrost or demist the mirror glass. See **Heated windows and mirrors** (page 86).

Electric folding mirrors

Note: When the mirrors are operated often during a short period of time, the system may become inoperable for a period of time to prevent damage due to overheating.

Note: The switch must be in position B.

The electric folding mirrors operate with the ignition on.



E122706

Press the button to fold or unfold the mirrors.

If you press the switch again while the mirrors are moving, they will stop and reverse the direction of movement.

AUTO-DIMMING MIRROR

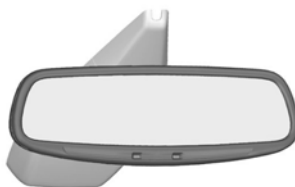

E71028

The auto-dimming mirror will adjust automatically when hit by glaring light from behind. It will not work when you have selected reverse gear.

Instruments

GAUGES

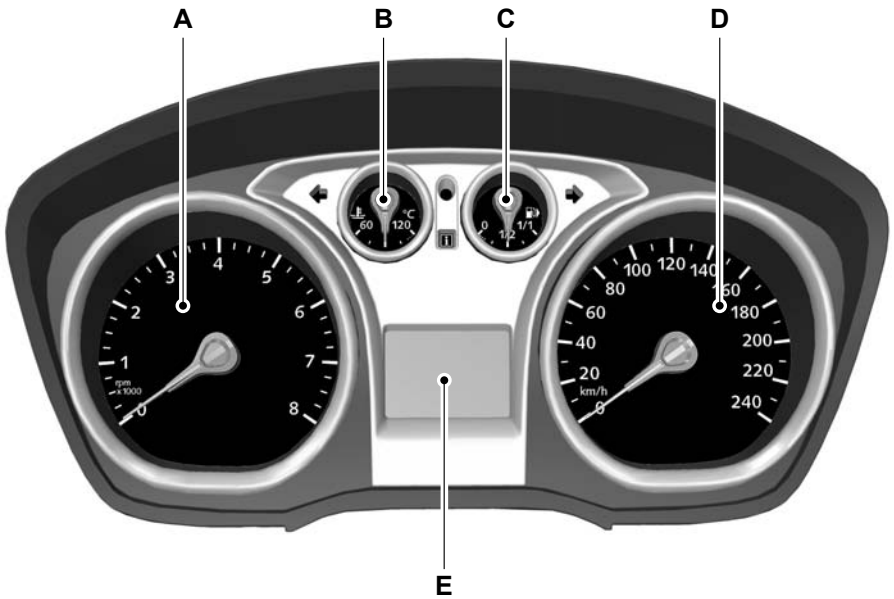

E98738

- A Tachometer
- B Engine coolant temperature gauge
- C Fuel gauge
- D Speedometer
- E Information display

Engine coolant temperature gauge

All vehicles

Shows the temperature of the engine coolant. At normal operating temperature, the needle will remain in the centre section.

CAUTION

- ⚠ Do not restart the engine until the cause of overheating has been resolved.

Instruments

If the needle enters the red section, the engine is overheating. Stop the engine, switch the ignition off and determine the cause **once the engine has cooled down**. See **Engine coolant check** (page 148).

Fuel gauge

The arrow adjacent to the fuel pump symbol indicates on which side of the vehicle the fuel filler cap is located.

WARNING LAMPS AND INDICATORS

The following warning lamps and indicators illuminate when the ignition is switched on:

- Airbag
- Oil pressure
- ABS
- Stability control (ESP)
- Engine
- Doors open
- Brake system
- Frost
- Power steering
- Ignition

If a warning or indicator lamp does not illuminate when the ignition is switched on, it indicates a malfunction. Have the system checked by properly trained technician.

ABS warning lamp



If it illuminates when you are driving, this indicates a malfunction. You will continue to have normal braking (without ABS). Have the system checked by a properly trained technician as soon as possible.

Airbag warning lamp



If it illuminates when you are driving, this indicates a malfunction. Have the system checked by a properly trained technician.

Brake system lamp



It illuminates when the parking brake is engaged.

WARNING



Reduce your speed gradually and stop your vehicle as soon as it is safe to do so. Use your brakes with care.

If it illuminates when you are driving, check that the parking brake is not engaged. If the parking brake is not engaged, this indicates a malfunction. Have the system checked by a properly trained technician immediately.

Cruise control indicator



It will illuminate when you have set a speed using the cruise control system. See **Using cruise control** (page 120).

Direction indicators



Flashes during operation. A sudden increase in the rate of flashing warns of a failed indicator bulb. See **Changing a bulb** (page 52).

Doors open warning lamp



Illuminates when the ignition is switched on and remains on if any door, the bonnet or the luggage compartment is not closed properly.

Instruments

Engine warning lamp



If it illuminates with the engine running, this indicates a malfunction. If it flashes when you are driving, **reduce the speed of your vehicle immediately**. If it continues to flash, avoid heavy acceleration or deceleration. Have the system checked by a properly trained technician immediately.

CAUTION



If the engine warning lamp illuminates in conjunction with a message, have the system checked as soon as possible.

Front fog lamp indicator



It will illuminate when you switch the front fog lamps on.

Frost warning lamp

WARNING



Even if the temperature rises to above +4°C there is no guarantee that the road is free of hazards caused by inclement weather.



It will illuminate and glow orange when the outside air temperature is between 4°C (39°F) and 1°C (34°F). It will glow red when the temperature is below 1°C (34°F).

Glow plug indicator



See (page 101).

Headlamp indicator



It will illuminate when you switch the headlamp dipped beam or the side and tail lamps on.

Ignition warning lamp



If it illuminates when you are driving, this indicates a malfunction. Switch off all unnecessary electrical equipment. Have the system checked by a properly trained technician immediately.

Low fuel level warning lamp



If it illuminates, refuel as soon as possible.

Main beam indicator



It will illuminate when you switch the headlamp main beam on. It will flash when you use the headlamp flasher.

Message indicator



It will illuminate when a new message is stored in the information display. See **Information messages** (page 73).

Oil pressure warning lamp

CAUTION



Do not resume your journey if it illuminates despite the level being correct. Have the system checked by a properly trained technician immediately.

Instruments



If it stays on after starting or illuminates when driving, this indicates a malfunction. Stop your vehicle as soon as it is safe to do so and switch the engine off. Check the engine oil level. See **Engine oil check** (page 147).

Power steering warning lamp



It illuminates to indicate a malfunction of the power steering system. Full steering will be maintained but you will need to exert greater force on the steering wheel. Have the system checked by a properly trained technician as soon as possible.

Rear fog lamp indicator



It will illuminate when you switch the rear fog lamps on.

Seat belt reminder



See **Seat belt reminder** (page 24).

Shift indicator



It will illuminate to inform you that shifting to a higher gear may give better fuel economy and lower CO₂ emissions. It will not illuminate during periods of high acceleration, braking or when the clutch pedal is pressed.

Stability control (ESP) indicator



While driving, it flashes during activation of the system. After switching on the ignition, if it does not illuminate or illuminates continuously while driving, this indicates a malfunction. During a malfunction, the system switches off. Have the system checked by a properly trained technician as soon as possible.

If you switch ESP off, the warning lamp will illuminate. The lamp will go out when you switch the system back on or when you switch the ignition off.

AUDIBLE WARNINGS AND INDICATORS

Automatic transmission

If position **P** is not selected, a warning chime will sound when the driver's door is opened.

Frost

WARNING



Even if the temperature rises to above +4°C there is no guarantee that the road is free of hazards caused by inclement weather.

A warning chime will sound in the following conditions:

- +4°C or lower: frost warning
- 0°C or lower: danger of icy roads.

Key outside car

Vehicles with keyless entry

If the engine is running and a passive key is no longer detected within the vehicle interior, a chime will sound as soon as the door is closed.

Instruments

Key-in-ignition

Except vehicles with keyless entry

A warning tone will sound when the driver's door is opened if:

- the key is in the ignition.

Vehicles with keyless entry

A warning tone will sound when the driver's door is opened if:

- the ignition is still on
- the spare key is in the ignition.

Lights on

A warning chime will sound if the driver's door is opened with the exterior lights switched on and the ignition switched off.

Low fuel

A warning chime will sound at the following ranges: 80 km (50 miles), 40 km (25 miles), 20 km (12 miles), 0 km (0 miles).

Seat belt reminder

See **Seat belt reminder** (page 24).

Information displays

GENERAL INFORMATION

WARNING



Do not operate the information display controls when the vehicle is moving.

Note: The information display will remain on for several minutes after you switch off the ignition.

Various systems on your vehicle can be controlled using the multi-function lever on the steering column. Corresponding information is displayed in the information display.

For detailed instructions on navigation, refer to the appropriate manual.

Controls

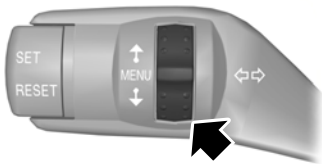

E73265

Use the rotary control:

- to scroll through the trip computer displays
- to scroll through and highlight the options within a menu.

Note: To scroll automatically, hold the rotary control in the upward or downward position.



E73266

Press the **SET/RESET** button to:

- enter the main menu from the trip computer displays
- enter a sub-menu
- exit a menu
- choose and confirm a setting.

Note: If the chimes are activated, a short tone will sound each time the button is pressed.

Information displays

Menu structure

ESP

Reset Trip

- Trip Odo
- Avg Fuel
- Avg Speed
- All

Messages

Steering

- Standard
- Sport
- Comfort

Clock

- Set Clock
- 24 Hour Mode

Setup

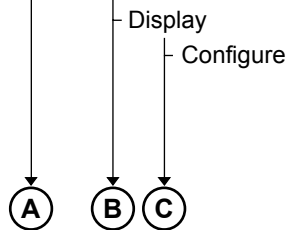

- Help Screen
- NAV Info
- Always off
- On Guidance
- Always on

E98875

Information displays

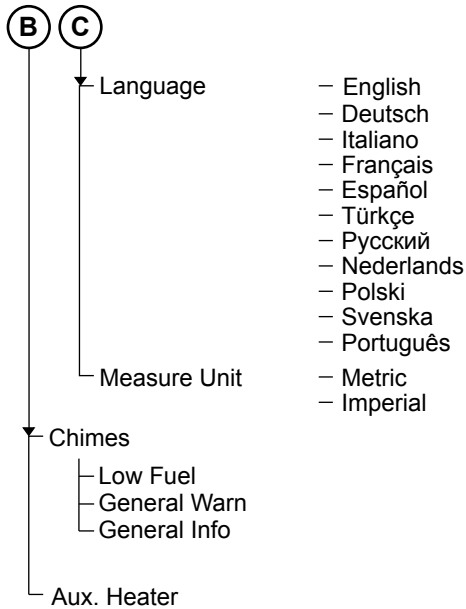

E98876

Information displays

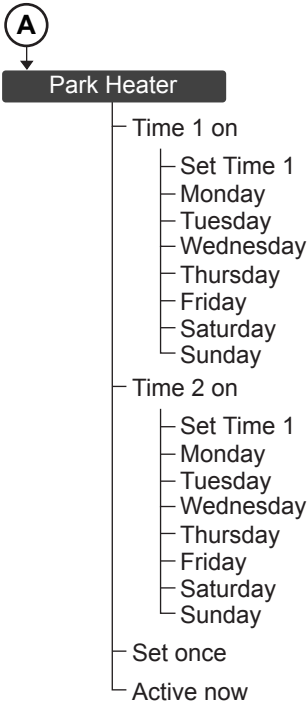

E98884

PERSONALISED SETTINGS

1. Use the rotary to enter the main menu.
2. Press the **SET/RESET** button to choose a sub-menu and adjust the settings.

ESP

Select this option to activate or deactivate ESP.

1. Use the rotary control to enter the main menu.

2. Highlight **ESP** and press the **SET/RESET**.
3. Highlight **Back** and repeatedly press the **SET/RESET** button to return to the main menu.

Steering

Note: For road safety reasons, changes in the **Steering** menu can only be made while the vehicle is stationary. If this menu or one of its sub-menus is open when the vehicle begins to move, the information display will automatically exit the **Steering** menu.

Note: When the vehicle is stationary, the steering assistance is optimized in all three settings and does not differ noticeably.

Standard: The standard setting is suitable for all driving styles.

Sport: The steering assistance is reduced. This suits a sportier driving style by increasing the feedback through the steering wheel. The sport setting is also an advantage when driving on icy and snowy road conditions.

Comfort: The steering assistance is increased. The steering will feel lighter and you will not need to exert as much force on the wheel.

1. Use the rotary control to enter the main menu.
2. Highlight **Steering** and press the **SET/RESET** button.
3. Highlight the desired setting and press the **SET/RESET** button to confirm the setting.
4. Highlight **Back** and repeatedly press the **SET/RESET** button to return to the main menu.

Clock setting

1. Use the rotary control to enter the main menu.

Information displays

2. Highlight **Clock** and press the **SET/RESET** button.
3. Highlight **Set Clock** and press the **SET/RESET** button. The hours start to flash.
4. Use the rotary control to adjust the hours to the desired setting.
5. Press the **SET/RESET** button to confirm the setting. The minutes start to flash.
6. Proceed in the same way to set the minutes and the date.
7. Press the **SET/RESET** button to confirm the setting.
8. Highlight **Back** and repeatedly press the **SET/RESET** button to return to the main menu.

Help screen and navigation information

The help screen appears for a few seconds when you switch the ignition on. If the navigation is operating, information relating to this system is displayed in the information display.

To select which information is displayed in the information display:

1. Use the rotary control to enter the main menu.
2. Highlight **Setup** and press the **SET/RESET** button.
3. Highlight **Display** and press the **SET/RESET** button.
4. Highlight **Configure** and press the **SET/RESET** button.
5. Highlight the desired setting and press the **SET/RESET** button to confirm the setting.
6. Highlight **Back** and repeatedly press the **SET/RESET** button to return to the main menu.

Navigation information

You can also choose when the navigation information is displayed in the information display. Three options are available:

- **Always off:** No navigation information is displayed in the information display.
- **On guidance:** The navigation information will only appear when the navigation system provides a guidance instruction. This function is only available on certain navigation systems.
- **Always on:** Navigation information will always appear in the information display when the navigation system is operating.

To set when navigation information should be displayed:

1. Use the rotary control to enter the main menu.
2. Highlight **Setup** and press the **SET/RESET** button.
3. Highlight **Display** and press the **SET/RESET** button.
4. Highlight **Configure** and press the **SET/RESET** button.
5. Highlight **Nav Info** and press the **SET/RESET** button.
6. Highlight the desired setting and press the **SET/RESET** button to confirm the setting.
7. Highlight **Back** and repeatedly press the **SET/RESET** button to return to the main menu.

Language setting

A choice of eleven languages are available.

English, German, Italian, French, Spanish, Turkish, Russian, Dutch, Polish, Swedish and Portuguese.

Information displays

1. Use the rotary control to enter the main menu.
2. Highlight **Setup** and press the **SET/RESET** button.
3. Highlight **Display** and press the **SET/RESET** button.
4. Highlight **Language** and press the **SET/RESET** button.
5. Highlight the desired setting and press the **SET/RESET** button to confirm the setting.
6. Highlight **Back** and repeatedly press the **SET/RESET** button to return to the main menu.

Units of measure

To select metric or imperial units:

Toggling the units of measure using this display will affect the following displays:

- Distance to empty.
- Average fuel consumption.
- Instantaneous fuel consumption.
- Average speed.
- Outside air temperature.
- The temperature display in the automatic climate control.

Note: *The units of measure for outside air temperature and the automatic climate control can be toggled independent of the other displays. When showing the outside air temperature, press and hold the **SET/RESET** button for a short time.*

1. Use the rotary control to enter the main menu.
2. Highlight **Setup** and press the **SET/RESET** button.
3. Highlight **Display** and press the **SET/RESET** button.
4. Highlight **Measure Unit** and press the **SET/RESET** button.

5. Highlight the desired setting and press the **SET/RESET** button to confirm the setting.
6. Highlight **Back** and repeatedly press the **SET/RESET** button to return to the main menu.

Chime deactivation

The following chimes can be deactivated:

- Low fuel warning.
 - General warning messages.
 - General information messages.
1. Use the rotary control to enter the main menu.
 2. Highlight **Setup** and press the **SET/RESET** button.
 3. Highlight **Chimes** and press the **SET/RESET** button.
 4. Highlight the desired setting and press the **SET/RESET** button to confirm the setting.
 5. Highlight **Back** and repeatedly press the **SET/RESET** button to return to the main menu.

INFORMATION MESSAGES

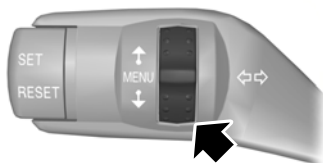

E73265

Information displays



E73266

Press **SET/RESET** to acknowledge and remove some messages from the information display. Other messages will be removed automatically after a short time.

With instrument cluster type 2 and 3, certain messages need to be confirmed before you can access the menus.

Message indicator



The message indicator illuminates to supplement some messages. It will be red or amber depending on the severity of the message and will remain on until the cause of the message has been rectified.

All wheel drive

Message	Warning lamp	Action
AWD overheated now disabled	amber	The vehicle can still be driven but have the system checked by a properly trained technician as soon as possible.
AWD malfunction	red	Have your vehicle checked by a properly trained technician.

Message symbols



See Owner's handbook.



Have the system checked at the next service.



Have the system checked as soon as possible.



Stop your vehicle as soon as it is safe to do so.

Viewing current messages

1. Press the **SET/RESET** button to enter the main menu.
2. Scroll to the messages display using the rotary control and press the **SET/RESET** button.
3. Turn the rotary control to scroll through the available messages.
4. Press **SET/RESET** twice to exit the menu.

Information displays

Doors open

Message	Warning lamp	Action
Driver door open	red	Vehicle is moving. Stop the vehicle as soon as safely possible and close.
Driver side rear door open	red	Vehicle is moving. Stop the vehicle as soon as safely possible and close.
Passenger door open	red	Vehicle is moving. Stop the vehicle as soon as safely possible and close.
Passenger side rear door open	red	Vehicle is moving. Stop the vehicle as soon as safely possible and close.
Luggage comp. open	red	Vehicle is moving. Stop the vehicle as soon as safely possible and close.
Bonnet open	red	Vehicle is moving. Stop the vehicle as soon as safely possible and close.
Door ajar close door	amber	Vehicle not moving. Close.

Keyless system

Message	Warning lamp	Action
Immobiliser malfunction	red	Have the system checked by a properly trained technician.
Steering malfunction	red	You will ONLY be able restart your vehicle up to a maximum of five times or for a period of up to 56 hours after which the vehicle cannot be started. Have the system checked by a properly trained technician as soon as possible.
Key not detected	amber	See Keyless entry (page 31).
Key outside car	amber	See Keyless entry (page 31).

Information displays

Message	Warning lamp	Action
Remote key battery low	amber	See Changing the remote control battery (page 27).
Steering malfunction	-	Have the system checked by a properly trained technician.
To start press brake	-	See Keyless starting (page 101).
To start press clutch	-	See Keyless starting (page 101).

Lighting

Message	Warning lamp	Action
Brake light fault	red	Brake lamp switch. The vehicle can be driven as normal. However, cruise control cannot be switched on. Have the system checked by a properly trained technician as soon as possible.
Adaptive front light failure	amber	Have the system checked by a properly trained technician.

Maintenance

Message	Warning lamp	Action
High engine temperature	red	Have the system checked by a properly trained technician.
Low brake fluid level	red	See Brake and clutch fluid check (page 149).
Engine malfunction	red	Stop the vehicle as soon as safely possible and switch off the engine immediately. Have the system checked by a properly trained technician immediately.

Information displays

Message	Warning lamp	Action
Acceleration reduced	red	Electronic acceleration control (EAC). The vehicle can be driven but the acceleration rate will be noticeably reduced. Maximum vehicle speed will be maintained. Have the system checked by a properly trained technician as soon as possible.
Low washer fluid level	amber	Appears only on vehicles fitted with headlamp washers. The washer fluid level is low. Check the washer fluid level. See Washer fluid check (page 149).
Service oil	-	Have the system checked by a properly trained technician.

Power steering

Message	Warning lamp	Action
Power steering malfunction	amber	Full steering will be maintained but you will need to exert greater force on the steering wheel. Have the system checked by a properly trained technician as soon as possible.

Stability control (ESP)

Message	Warning lamp	Action
ESP malfunction	amber	Have the system checked by a properly trained technician.

Information displays

Transmission

Message	Warning lamp	Action
Transmission limited function	amber	Automatic transmission. The vehicle can still be driven but have the system checked by a properly trained technician as soon as possible.
Transm. too hot. Press brake	red	Under certain driving conditions it is possible that the clutches in the transmission can overheat. In these circumstances it is necessary to press the brake pedal and stop the vehicle to prevent damage to the transmission. Select N (NEUTRAL) or P (PARK) and apply the parking brake until the transmission has cooled and the message disappears from the display.
Transmission too hot	red	The transmission is too hot. In these extreme conditions the transmission will disengage drive in order to prevent damage. You will not be able to drive until the transmission has cooled.
Transmission malfunction	amber	Have the system checked by a properly trained technician.
Engagement in progress Press brake pedal	-	At low outside temperatures, after starting the engine, it may take the transmission several seconds to engage R (REVERSE) or D (DRIVE) . Keep the brake pedal depressed until these messages disappear from the display.
Move shifter to P	-	See Automatic transmission (page 108). See Starting the engine (page 101).

Information displays

Tyre pressure monitoring system

Message	Warning lamp	Action
Check tyre pressures	amber	The pressure in one or more tyres has dropped. Check as soon as possible.
Tyre Press. Sys malfunction	amber	Permanent malfunction. Have the system checked by a properly trained technician.

Climate control

PRINCIPLE OF OPERATION

Outside air

Keep the air intakes forward of the windscreen free from obstruction (snow, leaves etc.) to allow the climate control system to function effectively.

Recirculated air

CAUTION

⚠ Prolonged use of recirculated air may cause the windows to mist up. If the windows mist up, follow the settings for defrosting and demisting the windscreen.

The air currently in the passenger compartment will be recirculated. Outside air will not enter the vehicle.

Heating

Heating performance depends on the temperature of the engine coolant.

Air conditioning

Note: *The air conditioning operates only when the temperature is above 4°C (39°F).*

Note: *If you use the air conditioning, the fuel consumption of your vehicle will be higher.*

Air is directed through the evaporator where it is cooled. Humidity is extracted from the air to help keep the windows free of mist. The resulting condensation is directed to the outside of the vehicle and it is therefore normal if you see a small pool of water under your vehicle.

General information on controlling the interior climate

Fully close all the windows.

Warming the interior

Direct the air towards your feet. In cold or humid weather conditions, direct some of the air towards the windscreen and the door windows.

Cooling the interior

Direct the air towards your face.

AIR VENTS

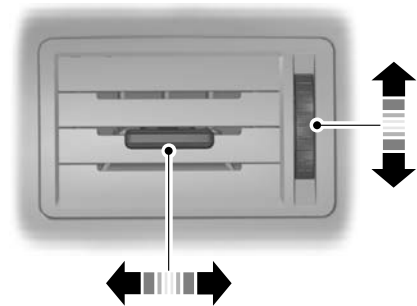

E77930

Climate control

MANUAL CLIMATE CONTROL

Air distribution control

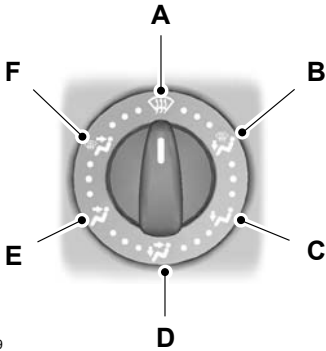

E71379

- A Windscreen
- B Footwell and windscreen
- C Footwell
- D Face level and footwell
- E Face level
- F Face level and windscreen

You can set the air distribution control to any position between the symbols.

Blower

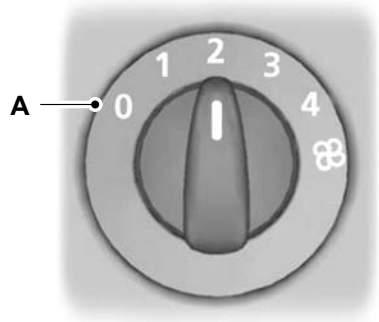

E75470

- A Off

Note: If you switch the blower off, the windscreen may mist up.

Recirculated air



Press the button to toggle between outside air and recirculated air.

Heating the interior quickly



E71377

Climate control

Ventilation



E71378

Set the air distribution control, blower and air vents to suit your requirements.

Air conditioning

Switching the air conditioning on and off



If you turn the blower off, the air conditioning will turn off. When you turn the blower on again, the air conditioning will come on automatically.

Cooling with outside air



E71380

Cooling the interior quickly

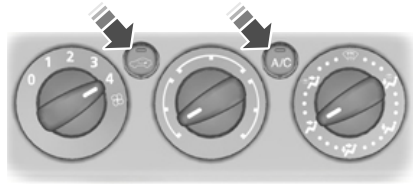

E71381

Defrosting and demisting the windscreen

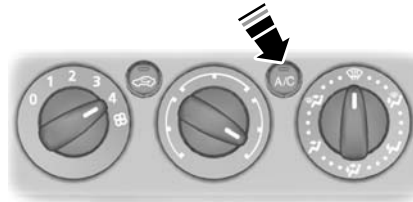

E71382

When the temperature is above 4°C (39°F), the air conditioning will switch on automatically. Make sure that the blower is on. The indicator in the switch will illuminate during defrosting and demisting.

If you move the air distribution control to a position other than **A**, the **A/C** will remain on.

You can switch the air conditioning and recirculated air on and off while the air distribution control is set to position **A**.

If necessary, switch the heated windows on. See **Heated windows and mirrors** (page 86).

Note: To defrost or demist the rear side windows, set the second row air vents to the defrosting and demisting position. See **Air vents** (page 80).

Climate control

Reducing interior air humidity

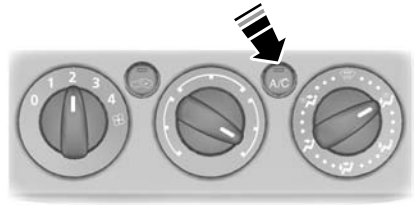

E71383

AUTOMATIC CLIMATE CONTROL



E91390

The system controls the temperature, amount and distribution of the air flow automatically and adjusts them according to the driving and weather conditions. Pressing the **AUTO** button once switches on the auto mode.

The system in your vehicle is dual-zone automatic climate control. When the system is in mono mode, all the temperature zones are linked to the driver's zone. When you switch mono mode off, the dual-zone system allows you to set different temperatures for the driver's and front passenger's side.

Note: Avoid adjusting the settings when the vehicle interior is extremely hot or cold. The automatic climate control adjusts to the current circumstances automatically. For the system to function properly, the side and centre vents should be fully open.

Note: The sunload sensor is located on top of the instrument panel. Do not cover the sensor with any objects.

Note: At low outside temperatures, when the system is in auto mode, the air stream will be directed to the windscreen and the side windows as long as the engine is cold.

Climate control

Note: For information on the automatic climate control, on vehicles fitted with a combined Navigation and automatic climate control system, see separate handbook.

Setting the temperature



E91391

You can set the temperature between 16°C and 28°C in steps of 0.5°C. In position **LO** (below 16°C) the system will switch to permanent cooling, in **HI** (above 28°C) to permanent heating, and not regulate a stable temperature.

Mono mode

In mono mode, the temperature settings for both the driver's and passenger's side are linked. If you adjust the temperature using the rotary control on the driver's side, the settings will be adjusted to the same setting on the passenger's side. In mono mode, MONO appears in the display.

To switch mono mode off

Select a temperature for the passenger's side with the rotary control on the passenger's side. Mono mode will switch off and **MONO** disappears from the display. The temperature for the driver's side will remain unchanged. You can now adjust the driver and passenger side temperatures independently of each other. The temperature settings for each side are shown in the display. You can set a temperature difference of up to 4°C.

Note: If you set a temperature of greater than 4°C, the temperature on the other side will be adjusted so that the difference remains 4°C.

Note: If you set one of the sides to **HI** or **LO**, both sides will be set to **HI** or **LO**.

To switch mono mode back on



To switch mono mode back on, press the **MONO** button. **MONO** reappears in the display and the passenger's side temperature will be adjusted to the driver's side temperature.

Blower



Use the buttons to adjust the blower speed.

The blower setting is indicated in the display.

To return to auto mode, press the **AUTO** button.

Climate control

Air distribution

To adjust air distribution, press the desired button. Any combination of settings can be selected simultaneously.

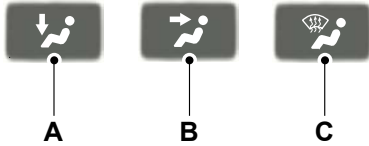

E70308

- A Footwell
- B Face level
- C Windscreen

When you select windscreen defrosting and demisting, **A**, **B** and **C** switch off automatically and the air conditioning switches on. Outside air will flow into the vehicle. You cannot select recirculated air.

Windscreen defrosting and demisting



Press the windscreen defrosting and demisting button. Outside air will flow into the vehicle. Air conditioning is automatically selected. As long as the air distribution is set to this position, you cannot select recirculated air.

The blower speed and the temperature control operate automatically and cannot be adjusted manually. The blower is set to high speed and the temperature to **HI**.

When you select windscreen defrosting and demisting, the heated screens switch on automatically and switch off after a short time.

To return to auto mode, press the **AUTO** button.

Switching the air conditioning on and off



Press the **A/C** button to switch the air conditioning on and off. **A/C OFF** appears in the display when the air conditioning is switched off.

A/C ON appears in the display when the air conditioning is switched on.

Recirculated air



Press the recirculated air button to toggle between outside air and recirculated air.

Note: When the system is in auto mode and the interior and exterior temperatures are quite hot, the system selects recirculated air automatically to maximise cooling of the interior. Once the selected temperature is reached, the system will reselect outside air automatically.

Switching off the automatic climate control



Press the **OFF** button.

When switched off, the heating, ventilation and air conditioning system is switched off and recirculated air is selected.

Climate control

HEATED WINDOWS AND MIRRORS

Heated windows

Use the heated windows to defrost or demist the windscreen or rear window.

Note: The heated windows operate only when the engine is running.

Heated windscreen



Heated rear window



Heated exterior mirrors

Electric exterior mirrors are fitted with a heating element that will defrost or demist the mirror glass. They will switch on automatically when you switch the heated rear window on.

AUXILIARY HEATER

Parking heater

WARNINGS



The parking heater must not be operated at filling stations, near sources of combustible vapours or dust or in enclosed spaces.



The parking heater should be switched on for approximately 10 minutes at least once a month all year round. This prevents the water pump and heater motor from seizing.

Note: The parking heater will only operate if there is at least 7.5 litres (1.6 gallons) of fuel in the fuel tank and the ambient temperature is below 15°C (59°F). The heater will not operate if the battery is low.

Note: The heating depends on the outside air temperature.

Note: When the parking heater is activated, exhaust fumes may come from under the sides of the vehicle. This is normal.

Note: On vehicles with manual climate control the heating of the vehicle interior is dependent on the temperature, air distribution and blower control settings.

The parking heater operates independently of the vehicle heater by heating the engine's coolant circuit. It is fed from the vehicle fuel tank. You can also use it while the vehicle is in motion to help the vehicle heater warm up the interior more quickly.

Used properly, the parking heater provides the following benefits:

- It preheats the interior of the vehicle.
- It keeps the windows clear of ice in the event of frost and prevents condensation.
- It avoids cold starts and allows the engine to reach operating temperature sooner.

To prevent the battery from discharging:

- Once the parking heater has performed one heating cycle, the next programmed heating cycle will only be carried out if you have started the vehicle's engine in between.
- After a heating cycle, drive the vehicle for at least the period of the heating cycle.

Climate control

Programming the parking heater

Note: The programmed time is the time at which you wish the vehicle to be warm and ready to drive, not the time at which the heater switches on.

Note: You must programme the times at least 70 minutes in advance of the time you wish to set.

Note: You must set the time and date correctly.

To programme the heating times:

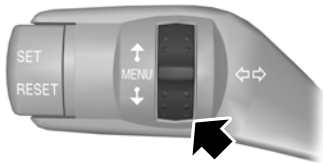

E73265



E73266

1. Use the rotary control to enter the main menu.
2. Highlight **Park Heater** and press the **SET/RESET** button.

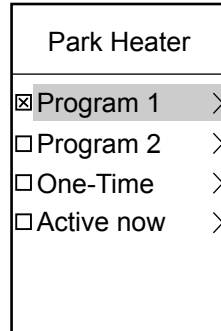

E74467

- The functions **Program 1** and **Program 2** allow you to programme up to two heating cycles for each day of the week. These times will remain stored and the heater will warm up the vehicle at these times on these days every week.
- The function **One-Time** allows you to programme one heating cycle for one specific day.
- The function **Active now** automatically switches on the heater.

Programming the functions Program 1 and Program 2

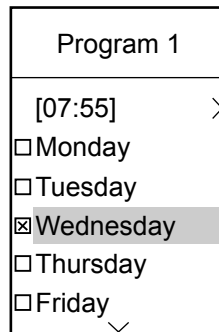

E74468

Climate control

1. Use the rotary control to enter the main menu.
2. Highlight **Program 1** and press the **SET/RESET** button.
3. Highlight the day on which the heater should warm up the vehicle.
4. Press the **SET/RESET** button to confirm the selection. A cross appears in the box next to the day to show that this day is selected.
5. Continue in the same way to select all the days on which the heater should warm up the vehicle.
6. To set the time at which the vehicle should be warmed up, highlight the time at the top of the display and press the **SET/RESET** button. The hours start to flash.
7. Use the rotary control to adjust the hours to the desired setting.
8. Press the **SET/RESET** button to confirm the setting. The minutes start to flash.
9. Use the rotary control to adjust the minutes to the desired setting.
10. Press the **SET/RESET** button to confirm the setting.
11. Press the **SET/RESET** button to exit the menu.

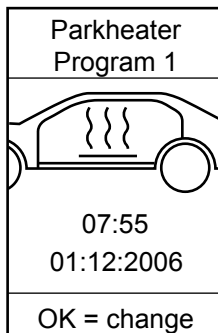

E74469

You can use the function **Program 2** to set a second cycle, for example different times on different days or twice on the same day. The programming procedure is the same as for the function **Program 1**.

Programming the function One-Time

1. Highlight **One-Time** and press the **SET/RESET** button. The hours start to flash.
2. Use the rotary control to adjust the hours to the desired setting.
3. Press the **SET/RESET** button to confirm the setting. The minutes start to flash.
4. Use the rotary control to adjust the minutes to the desired setting.
5. Press the **SET/RESET** button to confirm the setting.
6. Press the **SET/RESET** button to exit the menu.

Active now

1. Highlight **Active now** and press the **SET/RESET** button. A cross appears in the box next to the function to show that the heater is activated.

Climate control

To deactivate the heater, highlight **Active now** and press the **SET/RESET** button again.

Diesel auxiliary heater (depending on country)

The diesel auxiliary heater (PTC electrical heater) aids in warming the engine and the vehicle interior on vehicles with a diesel engine. It is switched on or off automatically depending on the outside air temperature, the coolant temperature and the alternator load.

Fuel operated heater (depending on country)

The fuel operated heater aids in warming the engine and the vehicle interior on vehicles with a petrol or diesel engine. It is switched on or off automatically depending on the outside air temperature and the coolant temperature, unless you have deactivated it. When the fuel operated heater is operating, a message appears in the information display. See **Information displays** (page 68).

To deactivate the fuel operated heater:

1. Use the rotary control to enter the main menu.
2. Highlight **Setup** and press the **SET/RESET** button.
3. Highlight **Aux. Heater** and press the **SET/RESET** button. A cross appears in the box when the heater is activated.
4. Press the **SET/RESET** button to exit the menu.

Seats

SITTING IN THE CORRECT POSITION

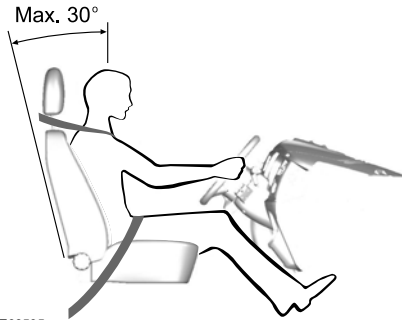

E68595

WARNINGS



Do not adjust the seats when the vehicle is moving.



Only when you use the seat belt properly, can it hold you in a position that allows the airbag to achieve its optimum effect.

When you use them properly, the seat, head restraint, seat belt and airbags will provide optimum protection in the event of a collision. We recommend that you:

- sit in an upright position with the base of your spine as far back as possible.
- do not recline the seatback more than 30 degrees.
- adjust the head restraint so that the top of it is level with the top of your head and as far forwards as possible, remaining comfortable.
- keep sufficient distance between yourself and the steering wheel. We recommend a minimum of 250 millimetres (10 inches) between your breastbone and the airbag cover.

- hold the steering wheel with your arms slightly bent.
- bend your legs slightly so that you can press the pedals fully.
- position the shoulder strap of the seat belt over the centre of your shoulder and position the lap strap tightly across your hips.

Make sure that your driving position is comfortable and that you can maintain full control of your vehicle.

HEAD RESTRAINTS

Adjusting the head restraint

WARNINGS



Raise the rear head restraint when the rear seat is occupied by a passenger.



When using a forward facing child restraint on a rear seat, always remove the head restraint from that seat.

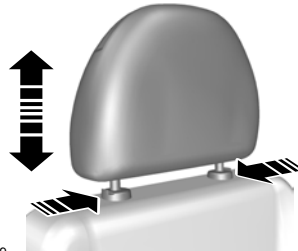

E66539

Adjust the head restraint so that the top of it is level with the top of your head.

Removing the head restraint

Press the locking buttons and remove the head restraint.

Seats

MANUAL SEATS

All vehicles

WARNINGS



Do not use any accessory seat covers that are not specifically designed for seats with side airbags. These seat covers must be fitted by properly trained technicians.



Do not adjust the seats while the vehicle is moving.

Moving the seats forwards or backwards

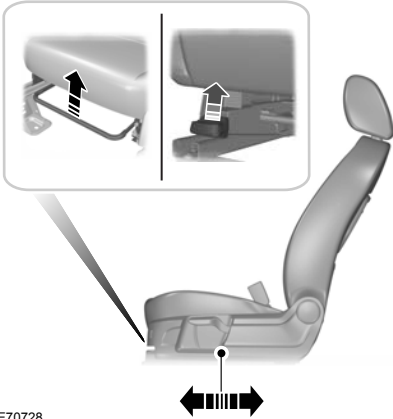

E70728

Pull the lever. Rock the seat to engage the catch.

Adjusting the lumbar support

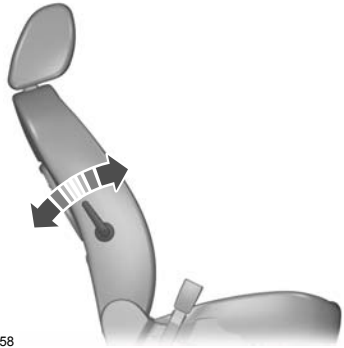

E78058

Adjusting the height of the driver's seat

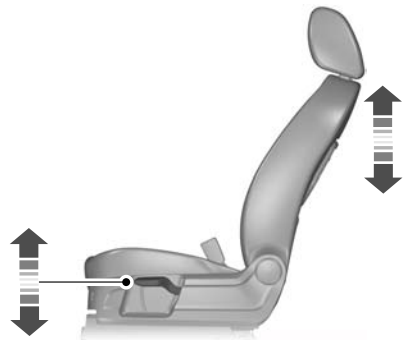

E70730

Each pull or press on the lever will raise or lower the height by a small amount.

Seats

Adjusting the angle of the seatback

When the seats are slid fully forward the seatbacks can be fully reclined.

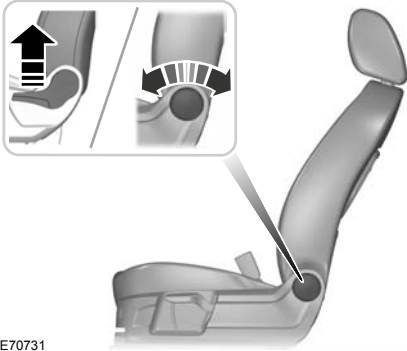

E70731

Seats

ELECTRIC SEATS

6-way electric seat

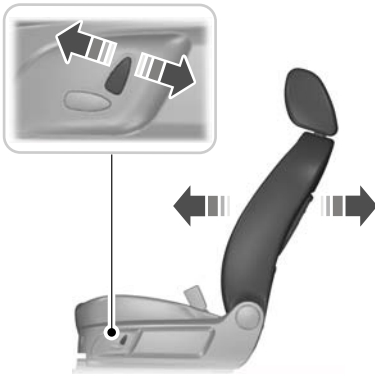
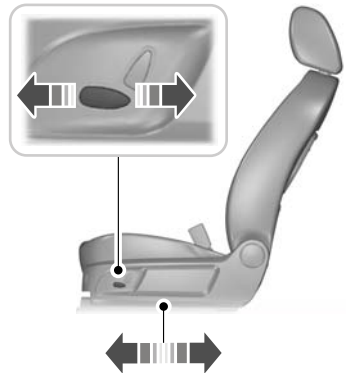
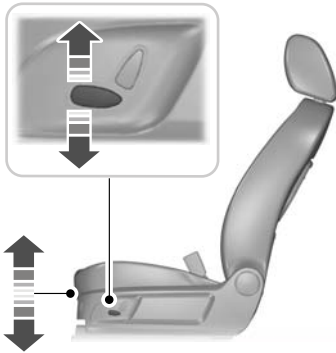

E78060

Seats

REAR SEATS

WARNINGS



When folding the seatbacks down, take care not to get your fingers caught between the seatback and seat frame.



Make sure that the seats and the seatbacks are secure and fully engaged in their catches.

Folding the seatbacks down

CAUTION



Lower the head restraints.



E86611

1. Press the unlock buttons down and hold them there.
2. Push the seatback forwards.

Creating a level load floor

WARNING



Make sure the red indicator is not showing when you engage the seat in the catches.

CAUTION



Lower the head restraints.

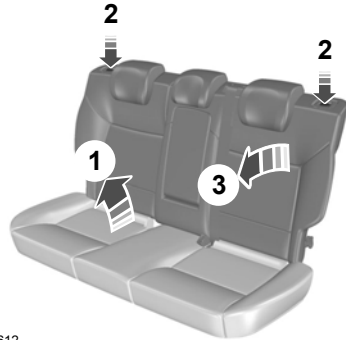

E86612

1. Insert your fingers between the seat cushion and seatback and fold the seat cushion forwards.
2. Press the unlock buttons down and hold them there.
3. Push the seatback forwards.

Folding the seatbacks up

WARNING



When folding the seatbacks up, make sure that the belts are visible to an occupant and not caught behind the seat.

HEATED SEATS

CAUTION



Operating this function with the engine off will drain the battery.

Seats

The heated front seats are operated by rotary controls in the instrument panel. For item location: See **Quick start** (page 8).

The maximum temperature is reached after five or six minutes. It is regulated thermostatically.

The seat heating will operate only when the ignition is on.

Convenience features

SUN BLINDS

Panoramic roof

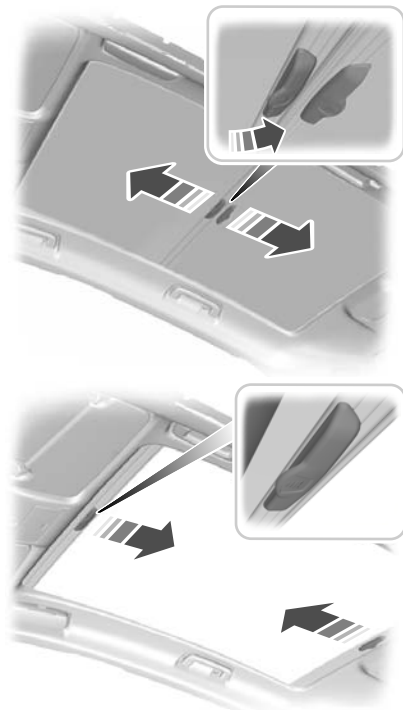

E91500

The roof blind is in two sections. Pull the handle from the front or rear of the panoramic roof and fully extend the required section.

To open the blind, slightly pull the handle against the spring mechanism, and push up to release from the hooks.

Note: Each blind section will only extend to the middle of the panoramic roof.

INSTRUMENT LIGHTING DIMMER



E70454

CUP HOLDERS

WARNING



Do not place hot drinks in the cup holders when the vehicle is moving.

Seat back trays

WARNING



Do not use the trays when the vehicle is moving. Make sure that you secure the trays in the lowered position before setting off.

Convenience features



E72630

CIGAR LIGHTER

CAUTIONS

- ! If you use the socket when the engine is not running, the battery may discharge.
- ! Do not hold the cigar lighter element pressed in.

Note: Switch the ignition on to use the cigar lighter. You can also use it for up to 30 minutes after you have switched the ignition off.

Note: You can use the socket to power 12 volt appliances that have a maximum current rating of 15 Amperes. Use only Ford accessory connectors or connectors specified for use with SAE standard sockets.

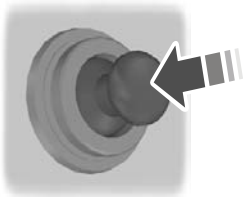

E72972

Press the element in to use the cigar lighter. It will pop out automatically.

AUXILIARY POWER SOCKETS

CAUTION

- ! If you use the socket when the engine is not running, the battery may discharge.

Note: You can use the socket to power 12 volt appliances that have a maximum current rating of 10 Amperes. Use only Ford accessory connectors or connectors specified for use with SAE standard sockets.



E78056

Auxiliary power sockets are located in the centre console and in the luggage compartment.

Power inverter

CAUTIONS

- ! If you use the socket when the engine is not running, the battery may discharge.
- ! If the LED flashes continuously, re-insert the plug or switch the ignition off and then on again.
- ! It will switch off if the temperature is above 85°C (185°F). The LED will flash once. When it has cooled down it will switch back on automatically.

Convenience features

CAUTIONS

⚠ Do not exceed the maximum power output. If you do, the LED will flash twice. Remove the plug and re-insert it.

⚠ If the LED flashes 3 or 4 times, have the system checked by a properly trained technician.

Note: You can use the socket to power 230 volt appliances that have a maximum rating of 150 watts.



E98199

STORAGE COMPARTMENTS

Front storage compartment



E99181

Note: Avoid keeping heat-sensitive objects and liquids in the front storage compartment.

Storage area under the rear seats



E99182

Convenience features

To gain access to the storage area, fold up the rear seat cushions. See **Rear seats** (page 94).

Note: Do not overload the storage areas under the rear seats. Ensure that the rear seat cushions can be folded back completely.

GLASSES HOLDER

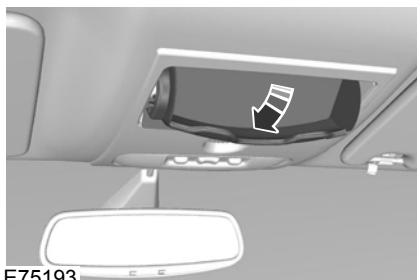

E75193

TOLL READER

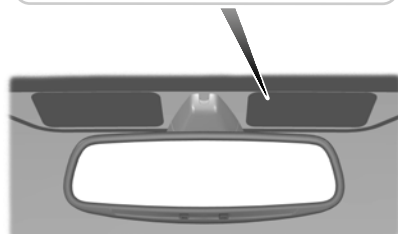
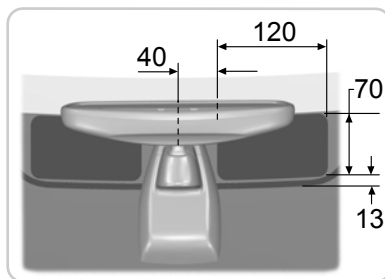

E99272

On vehicles with an anti-heat windscreen, toll readers should be placed in the area as shown (all measurements shown in millimetres), otherwise communication performance with toll stations may be reduced.

The toll reader should be placed on the passenger side to prevent the reader from obscuring the driver's vision (e.g. at traffic lights).

CD CHANGER

This is located under the front passenger seat.

AUXILIARY INPUT (AUX IN) SOCKET

See separate audio handbook.

Convenience features

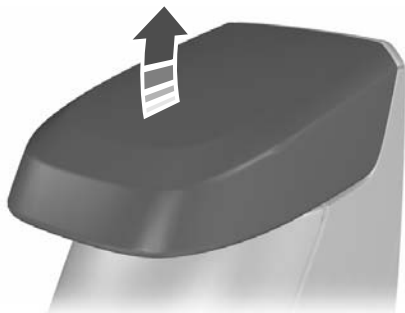

E91511



E91511

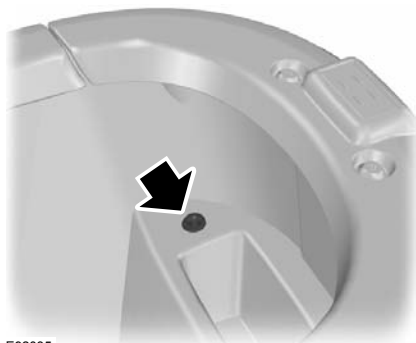

E92035

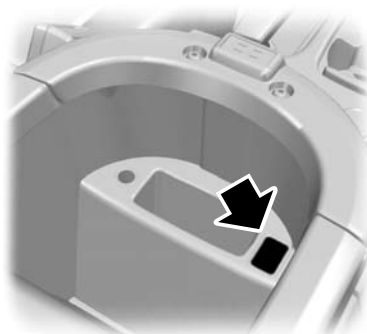

E99438

USB PORT

See **Using a USB device** (page 202).

FLOOR MATS

WARNING



When using the floor mats, always make sure the floor mat is properly secured using the appropriate fixings and positioned so that it does not interfere with the operation of the pedals.

Starting the engine

GENERAL INFORMATION

General points on starting

If the battery has been disconnected the vehicle may exhibit some unusual driving characteristics for approx. 8 kilometres (5 miles) after reconnecting the battery.

This is because the engine management system must realign itself with the engine. Any unusual driving characteristics during this period may be disregarded.

Starting the engine by towing or pushing

WARNING



To prevent damage you must not push or tow start your vehicle. Use booster cables and a booster battery. See **Using booster cables** (page 154).

KEYLESS STARTING

WARNINGS



The keyless starting system may not function if the key is close to metal objects or electronic devices such as mobile phones.



Always check that the steering wheel lock is deactivated before attempting to move your vehicle.

Note: A valid passive key must be located inside the vehicle to switch the ignition on and start the engine.

Note: To start your engine you must also fully depress the brake or clutch pedal, depending on the transmission fitted.



E85766

Ignition on

Press the start button once. All electrical circuits are operational, warning lamps and indicators illuminate.

Starting with automatic transmission

Note: Releasing the brake pedal during engine start will stop the engine cranking and return to ignition on.

1. Make sure the transmission is in **P** or **N**.
2. Fully depress the brake pedal.
3. Briefly press the start button.

Starting with manual transmission

Note: Releasing the clutch pedal during engine start will stop the engine cranking and return to ignition on.

1. Fully depress the clutch pedal.
2. Briefly press the start button.

Starting a diesel engine

Note: Engine cranking will not commence until the engine glow plug cycle has been completed. This may take several seconds in extremely cold conditions.

Note: Continue to press the clutch or brake pedal until engine cranking begins.

Starting the engine

Failure to start

The passive starting system will not function if:

- The passive key frequencies are jammed.
- The passive key battery is flat.

If you are unable to start your vehicle carry out the following procedure.

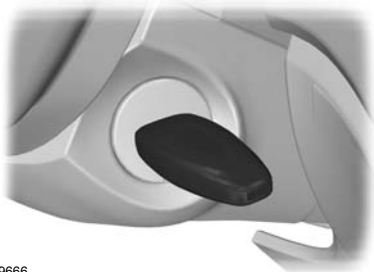

E99666

1. Hold the key next to the steering column shroud exactly as shown.
2. With the key in this position you can use the start button to switch the ignition on and start your vehicle.

If you are still unable to start your vehicle carry out the following procedure.

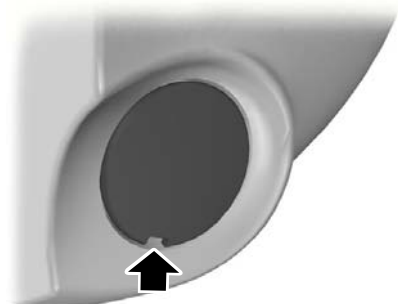

E87381

1. Carefully prise out the cover.

2. Remove the key blade. See **Keyless entry** (page 31).

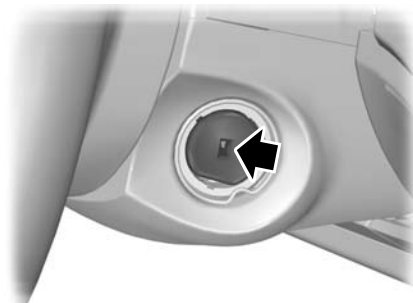

E99586

3. Insert the key blade into the key holder.
4. With the key blade in this position you can use the start button to switch the ignition on and start your vehicle.

Stopping the engine

When your vehicle is stationary, press the start button to stop the engine. The ignition, all electrical circuits, warning lamps and indicators will be switched off.

DIESEL PARTICULATE FILTER (DPF)

The DPF forms part of the emissions reduction systems fitted to your vehicle. It filters harmful diesel particulates (soot) from the exhaust gas.

Starting the engine

Regeneration

WARNING



Do not park or idle your vehicle over dry leaves, dry grass or other combustible materials. The DPF regeneration process creates very high exhaust gas temperatures and the exhaust will radiate a considerable amount of heat during and after DPF regeneration, and after you have switched the engine off. This is a potential fire hazard.

CAUTION



Avoid running out of fuel.

Note: *After you have switched your engine off the fans may continue to run for a short period of time.*

Unlike a normal filter which requires periodic replacement, the DPF has been designed to regenerate, or clean itself to maintain operating efficiency. The regeneration process takes place automatically. However, some driving conditions mean that you may need to support the regeneration process.

If you drive only short distances or your journeys contain frequent stopping and starting, where there is increased acceleration and deceleration, occasional trips with the following conditions could assist the regeneration process:

- Drive your vehicle at a constant speed, preferably on a main road or motorway, for up to 20 minutes.
- Avoid prolonged idling and always observe speed limits and road conditions.

- Do not switch off the ignition.
- Use a lower gear than normal to maintain a higher engine speed during this journey, where appropriate.

SWITCHING OFF THE ENGINE

Vehicles with a turbocharger

CAUTION



Do not switch the engine off when it is running at high speed. If you do, the turbocharger will continue running after the engine oil pressure has dropped to zero. This will lead to premature turbocharger bearing wear.

Release the accelerator pedal. Wait until the engine has reached idle speed and then switch it off.

Fuel and refuelling

SAFETY PRECAUTIONS

WARNINGS



Stop refuelling after the fuel nozzle stops the second time. Additional fuel will fill the expansion space in the fuel tank which could lead to fuel overflowing. Fuel spillage could be hazardous to other road users.



Do not use any kind of flames or heat near the fuel system. The fuel system is under pressure. There is a risk of injury if the fuel system is leaking.

FUEL QUALITY - PETROL

CAUTION



Do not use leaded petrol or petrol with additives containing other metallic compounds (e.g. manganese-based). They could damage the emission system.

Note: We recommend that you use only high quality fuel without additives or other engine treatments.

Use **minimum 95 octane unleaded** petrol that meets the specification defined by **EN 228**, or equivalent.

FUEL QUALITY - DIESEL

WARNING



Do not mix diesel with oil, petrol or other liquids. This could cause a chemical reaction.

CAUTIONS



Do not add kerosene, paraffin or petrol to diesel. This could cause damage to the fuel system.

CAUTIONS



Use diesel that meets the specification defined by **EN 590**, or the relevant national specification.

Note: We recommend that you use only high quality fuel.

Note: The use of additives or other engine treatments not approved by Ford is not recommended.

Note: We do not recommend the prolonged use of additives intended to prevent fuel waxing.

Long-term storage

Most diesel fuels contain bio-diesel, it is recommended to fill the tank with purely mineral diesel (where available) or add an anti-oxidant prior to long-term storage of your vehicle exceeding two months. Your dealer can help you with a suitable anti-oxidant.

FUEL FILLER FLAP

WARNINGS



Take care when refuelling to avoid spilling any residual fuel from the fuel nozzle.



Do not use any kind of flames or heat near the fuel system. The fuel system is under pressure. There is a risk of injury if the fuel system is leaking.

CAUTION



If you use a high pressure spray to wash your vehicle, only spray the fuel filler flap briefly from a distance not less than 20 centimetres (8 inches).

Fuel and refuelling

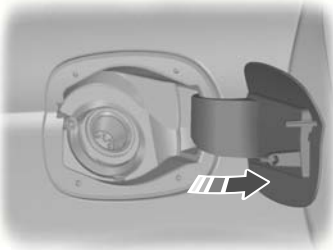

E86613

Press the flap to open it. Open the flap fully until it engages.

When you insert the fuel nozzle, a spring loaded inhibitor will open if the correct size nozzle is detected. This helps to avoid filling up with the wrong fuel.

WARNING



Stop refuelling after the fuel nozzle stops the second time. Additional fuel will fill the expansion space in the fuel tank which could lead to fuel overflowing. Fuel spillage could be hazardous to other road users.

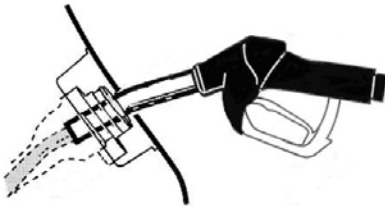

E119080

Insert the fuel nozzle up to and including the first notch on the nozzle. Keep it resting on the cover of the fuel pipe opening.

WARNING



We recommend that you wait at least 10 seconds before removing the fuel nozzle to allow any residual fuel to drain into the fuel tank.

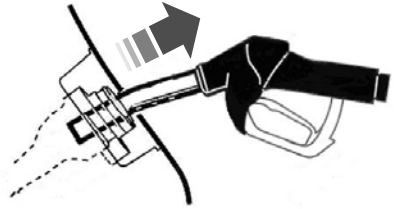

E119081

Slightly raise the fuel nozzle to remove it.

A funnel is located in the glove box. Use this when refilling with a fuel can.

CATALYTIC CONVERTER

WARNING



Do not park or idle your vehicle over dry leaves, dry grass or other combustible materials. The exhaust will radiate a considerable amount of heat during use, and after you have switched the engine off. This is a potential fire hazard.

Driving with a catalytic converter

CAUTIONS



Avoid running out of fuel.



Do not crank the engine for long periods.



Do not run the engine when a spark plug lead is disconnected.

Fuel and refuelling

CAUTIONS

- ⚠ Do not push-start or tow-start your vehicle. Use booster cables. See **Using booster cables** (page 154).
- ⚠ Do not switch the ignition off when driving.

REFUELLING

CAUTION

- ⚠ Do not attempt to start the engine if you have filled the fuel tank with the incorrect fuel. This could damage the engine. Have the system checked by a properly trained technician immediately.

FUEL CONSUMPTION

The CO₂ and fuel consumption figures are derived from laboratory tests according to EEC Directive 80/1268/EEC and subsequent amendments and are carried out by all vehicle manufacturers.

They are intended as a comparison between makes and models of vehicles. They are not intended to represent the real world fuel consumption you may get from your vehicle. Real world fuel consumption is governed by many factors including; driving style, high speed driving, stop/start driving, air conditioning usage, the accessories fitted and towing etc.

Your Ford dealer can give you advice on improving your fuel consumption.

TECHNICAL SPECIFICATIONS

6-speed manual transmission - 2WD

Fuel consumption figures

Variant	Urban	Extra-urban	Combined	CO ₂ emissions
	l/100 km (mpg)	l/100 km (mpg)	l/100 km (mpg)	g/km
2.0L Duratorq-TDCi stage IV	7.7 (36.7)	5.1 (55.4)	6.1 (46.3)	159
2.0L Duratorq-TDCi stage V	7.5 (37.7)	5.0 (56.5)	5.9 (47.9)	156

Fuel and refuelling

6-speed manual transmission - AWD

Fuel consumption figures

Variant	Urban	Extra-urban	Combined	CO2 emissions
	l/100 km (mpg)	l/100 km (mpg)	l/100 km (mpg)	g/km
2.0L Duratorq-TDCi stage IV	8.1 (34.9)	5.4 (52.3)	6.4 (44.1)	169
2.0L Duratorq-TDCi stage V	7.6 (37.2)	5.1 (55.4)	6.0 (47.1)	159
2.5L Duratec	13.9 (20.3)	7.6 (37.2)	9.9 (28.5)	234

6-speed automatic transmission - AWD

Fuel consumption figures

Variant	Urban	Extra-urban	Combined	CO2 emissions
	l/100 km (mpg)	l/100 km (mpg)	l/100 km (mpg)	g/km
2.0L Duratorq-TDCi stage V	8.5 (33.2)	5.8 (48.7)	6.8 (41.5)	179
2.5L Duratec	14.6 (19.3)	7.8 (36.2)	10.3 (27.4)	244

Transmission

MANUAL TRANSMISSION

CAUTION

 Do not engage reverse gear when the vehicle is moving. This can cause damage to the transmission.

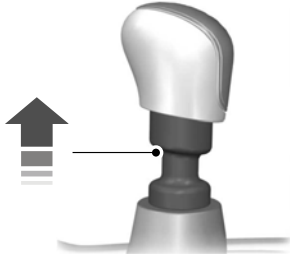

E99067

On some vehicles it is necessary to raise the collar whilst selecting reverse gear.

AUTOMATIC TRANSMISSION

Selector lever positions



E80836

- P Park
- R Reverse

- N Neutral
- D Drive
- S Sport mode and manual shifting

WARNING

 Apply the brakes before moving the selector lever and keep them applied until you are ready to move off.

Note: A cold engine has a higher idle speed. This will increase the tendency for your vehicle to **creep** when you have selected a drive gear.

Press the button on the selector lever to select reverse and park.

The selector lever position will be shown in the information display.

Park

WARNINGS

 Select park only when your vehicle is stationary.

 **Apply the parking brake and select park before leaving your vehicle.** Make sure that the selector lever is latched in position.

Note: An audible warning will sound if you open the driver's door and you have not selected park.

In this position, power is not transmitted to the drive wheels and the transmission is locked. You can start the engine with the selector lever in this position.

Transmission

Reverse

WARNING



Select reverse only when your vehicle is stationary and the engine is at idle speed.

Neutral

In this position, power is not transmitted to the drive wheels but the transmission is not locked. You can start the engine with the selector lever in this position.

Drive

Select drive to shift automatically through the forward gears.

The transmission will select the appropriate gear for optimum performance based on ambient temperature, road gradient, vehicle load and driver input.

Manual shifting - Vehicles with a 5 speed transmission

WARNING



Do not hold the selector lever permanently in - or +.

CAUTION



The transmission will automatically downshift when the engine speed is too low and upshift when too high.

Note: A shift will occur only when the vehicle speed and the engine speed are appropriate.

Note: In **Select** mode the current gear (1, 2, 3, 4 or 5) will be displayed on the instrument panel.

Move the selector lever to position **S**.

Push the selector lever forwards to shift down and pull it backwards to shift up.

Gears may be skipped by moving the selector lever repeatedly at short intervals.

Manual mode also provides a kickdown function. See **Kickdown**.

Sport mode and manual shifting - Vehicles with a 6 speed transmission

Note: A shift will occur only when the vehicle speed and the engine speed are appropriate.

Note: In **Sport** mode the transmission operates as normal but gears are selected more quickly and at higher engine speeds.

Note: In **Sport** mode **S** will be displayed on the instrument panel.

Sport Mode

Activate **Sport** mode by moving the selector lever to position **S**. **Sport** mode will remain active until either you shift manually up or down the gears or return the selector lever to position **D**.

Manual shifting

WARNING



Do not hold the selector lever permanently in - or +.

CAUTION



The transmission will automatically downshift when the engine speed is too low and upshift when too high.

Push the selector lever forwards to shift down and pull it backwards to shift up.

Gears may be skipped by moving the selector lever repeatedly at short intervals.

Manual mode also provides a kickdown function. See **Kickdown**.

Transmission

Hints on driving with an automatic transmission

Moving off

1. Release the parking brake.
2. Release the brake pedal and press the accelerator pedal.

Stopping

1. Release the accelerator pedal and press the brake pedal.
2. Apply the parking brake.

Kickdown

Press the accelerator pedal fully with the selector lever in the drive position to select the next lowest gear for optimum performance. Release the accelerator pedal when you no longer require kickdown.

Emergency park position release lever

Use the lever to move the selector lever from the park position in the event of an electrical malfunction or if your vehicle has a flat battery.

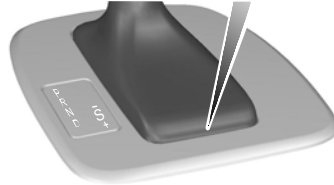
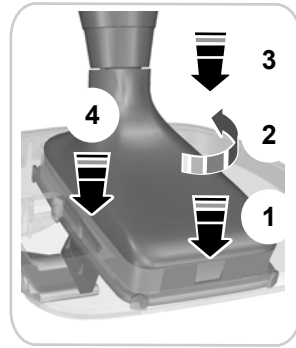

E125156

1. Insert a small flat-bladed tool into the slot.
2. Turn the tool through 90 degrees.
3. Push downwards on the tool to detach the gaiter frame from the trim panel.
4. Push downwards on the gaiter frame to release the lever and move the selector lever from the park position.
5. Pull upwards on the gaiter until the gaiter frame engages in the trim panel.

Note: If position **P** is selected again, this procedure must be repeated.

ALL-WHEEL DRIVE (AWD)

CAUTION

 A vehicle fitted with AWD must be recovered with either **ALL** wheels on the ground or **ALL** wheels off the ground. See **Vehicle recovery** (page 140).

The AWD system, fitted to certain front-wheel drive variants, will automatically provide driving torque to the rear wheels when road conditions become slippery with rain, snow or ice etc.

Brakes

PRINCIPLE OF OPERATION

Disc brakes

Wet brake discs result in reduced braking efficiency. Dab the brake pedal when driving from a car wash to remove the film of water.

ABS

WARNING



The ABS does not relieve you of your responsibility to drive with due care and attention.

The ABS helps you to maintain full steering and directional stability when you brake heavily in an emergency, by preventing the road wheels from locking.

HINTS ON DRIVING WITH ABS

When the ABS is operating, the brake pedal will pulse. This is normal. Maintain pressure on the brake pedal.

The ABS will not eliminate the dangers inherent when:

- you drive too close to the vehicle in front of you.
- the vehicle is aquaplaning.
- you take corners too fast.
- the road surface is poor.

PARKING BRAKE

All vehicles

WARNING



Vehicles with an automatic transmission should always be left with the selector lever in position **P**.

- Press the foot brake pedal firmly.
- Pull the parking brake lever up smartly to its fullest extent.
- Do not press the release button while pulling the lever up.
- If your vehicle is parked on a hill and facing uphill, select first gear and turn the steering wheel away from the kerb.
- If your vehicle is parked on a hill and facing downhill, select reverse gear and turn the steering wheel towards the kerb.

To release the parking brake, press the brake pedal firmly, pull the lever up slightly, depress the release button and push the lever down.

Stability control

PRINCIPLE OF OPERATION

Electronic stability programme (ESP)

WARNING



ESP does not relieve you of your responsibility to drive with due care and attention.

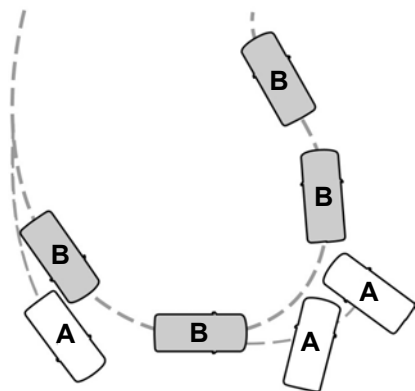

E72903

- A without ESP
- B with ESP

The ESP supports stability when the vehicle starts to slide away from your intended path. This is performed by braking individual wheels and reducing engine torque as needed.

The system also provides an enhanced traction control function by reducing engine torque if the wheels spin when you accelerate. This improves your ability to pull away on slippery roads or loose surfaces, and improves comfort by limiting wheel spin in hairpin bends.

Stability control (ESP) warning lamp

The ESP warning lamp will flash when the system is operating. See **Warning lamps and indicators** (page 64).

Emergency brake assist

WARNING



Emergency brake assist does not relieve you of your responsibility to drive with due care and attention.

Emergency brake assist will detect when you brake heavily by measuring the rate at which you press the brake pedal. It will provide maximum braking efficiency as long as you press the pedal. Emergency brake assist can reduce stopping distances in critical situations.

Trailer stability control

WARNINGS



Trailer stability control does not relieve you of your responsibility to tow with due care and attention.



Disabling ESP will turn off the system.

Trailer stability control is an enhanced feature of ESP, and automatically detects when an attached trailer starts to sway.

If this situation occurs, the system will automatically brake individual wheels to stabilise the trailer and vehicle. In case a very severe sway is detected, the engine torque will be reduced and the vehicle will be slowed automatically.

USING STABILITY CONTROL

Note: The system will be switched on automatically every time you switch the ignition on.

Stability control

To turn the system off and on. See **Information displays** (page 68).

Parking aid

PRINCIPLE OF OPERATION

WARNING



The parking aid does not relieve you of your responsibility to drive with due care and attention.

CAUTIONS



Vehicles fitted with a trailer tow module not approved by us may not correctly detect obstacles.



The sensors may not detect objects in heavy rain or other conditions that cause disruptive reflections.



The sensors may not detect objects with surfaces that absorb ultrasonic waves.



The parking aid does not detect obstacles moving away from the vehicle. They will only be detected shortly after they start to move towards the vehicle again.



Take particular care when reversing with a tow ball arm or rear fitted accessories e.g. a bicycle carrier, as the rear parking aid will only indicate the distance from the bumper to the obstacle.



If you use a high pressure spray to wash your vehicle, only spray the sensors briefly from a distance not less than 20 centimetres (8 inches).

Note: On vehicles fitted with a tow ball arm, the parking aid is deactivated automatically when any trailer lamps (or lighting boards) are connected to the 13-pin socket via a trailer tow module we have approved.

Note: Keep the sensors free from dirt, ice and snow. Do not clean with sharp objects.

Note: The parking aid may emit false tones if it detects a signal using the same frequency as the sensors or if the vehicle is fully laden.

Note: The outer sensors may detect the side walls of a garage. If the distance between the outer sensor and the side wall remains constant for three seconds, the tone will switch off. As you continue, the inner sensors will detect rearward objects.

USING THE PARKING AID

Switching the parking aid on and off

Note: The parking aid switches off automatically when you start the engine or when you exceed 16 km/h (10 mph).

Note: The front and rear sensors are always activated or deactivated together.

The parking aid is per default off. To switch the parking aid on, press the switch in the instrument panel or select reverse gear.

The light in the switch illuminates when the parking aid is activated.

To turn it off, press the switch again.

Manoeuvring with the parking aid

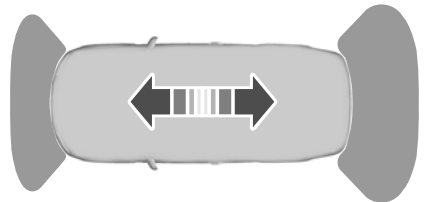

E72902

Parking aid

Note: *If a high pitch warning tone sounds for three seconds and the light in the switch is flashing, it indicates a malfunction. The system will be disabled. Have the system checked by properly trained technicians.*

You will hear an intermittent tone at a distance of up to approximately 150 centimetres (59 inches) between the obstacle and rear bumper, 80 centimetres (31 inches) between the obstacle and front bumper and 50 centimetres (20 inches) to the side. Decreasing the distance accelerates the intermittent tone. A continuous tone will start at a distance of less than 30 centimetres (12 inches).

You will hear an alternating tone from the front and rear if obstacles are closer than 30 centimetres (12 inches) to the front and rear bumpers.

Rear view camera

PRINCIPLE OF OPERATION

The camera is a visual aid for use when reversing.

WARNING



The camera does not relieve you of your responsibility to drive with due care and attention.

CAUTIONS



If you use a high pressure spray to wash your vehicle, only spray the camera briefly from a distance not less than 20 centimetres (8 inches).



Do not apply pressure to the camera. The position and the angle of the camera automatically changes.

Note: *Keep the camera free from dirt, ice and snow. Do not clean with sharp objects, degreaser, wax or organic products. Use only a soft cloth.*

During operation, guide lines appear in the display which represent your vehicle's path and approximate distance from rearward objects.

USING THE REAR VIEW CAMERA

WARNINGS



The operation of the camera may vary depending on the ambient temperature, vehicle and road conditions.



The distances shown in the display may differ from the actual distance.



Do not place objects in front of the camera.

The camera is located on the luggage compartment lid near the handle.



E99105

Activating the rear view camera

CAUTION



The camera may not detect objects that are close to the vehicle.

With the ignition and the audio unit switched on, engage reverse gear. The image is displayed on the screen.

The camera may not operate correctly in the following conditions:

- Dark areas.
- Intense light.
- If the ambient temperature increases or decreases rapidly.
- If the camera is wet, for example in rain or high humidity.
- If the camera's view is obstructed, for example by mud.

Using the display

CAUTIONS



Obstacles above the camera position will not be shown. Inspect the area behind your vehicle if necessary.

Rear view camera

CAUTIONS

 Marks are for general guidance only, and are calculated for vehicles in maximum load conditions on an even road surface.

The lines show a projected vehicle path (based on the current steering wheel angle) and the distance from the exterior mirrors and rear bumper.

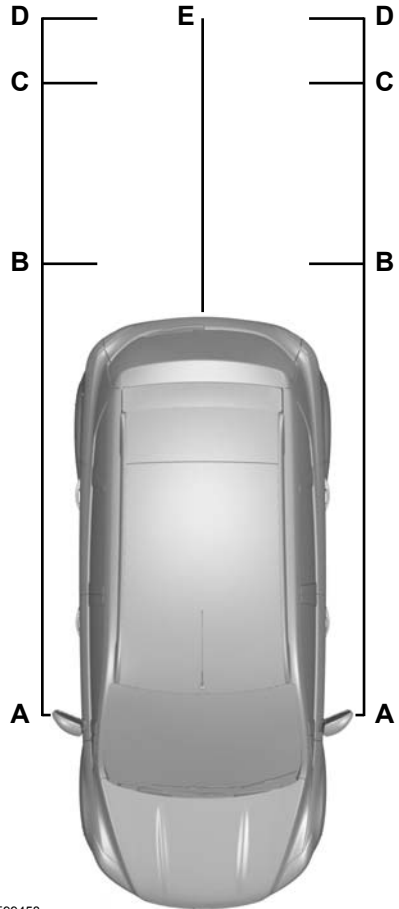

E99458

- A Exterior mirror clearance - 0.1 metre (4 inches)
- B Red - 0.3 metre (12 inches)
- C Amber - 1 metre (39 inches)

Rear view camera

- D Amber - 2 metres (79 inches)
- E Amber - centre line of the projected vehicle path

Note: *When reversing with a trailer, the lines on the screen show the vehicle direction and not the trailer.*

Deactivating the rear view camera

Note: *Disengage reverse gear. The display will stay on for a short period before switching off.*

The system will automatically switch off once the vehicle speed has reached approximately 15 km/h (9 mph).

Vehicles with parking aid

The display will additionally show a coloured distance bar. This guide indicates the distance from the rear bumper to the detected obstacle.

These are colour coded as follows:

- Green - 0.8 to 1.5 metres (31 to 59 inches).
- Amber - 0.3 to 0.8 metre (12 to 31 inches).
- Red - 0.3 metre (12 inches) or less.

Cruise control

PRINCIPLE OF OPERATION

Cruise control allows you to control your speed using the switches on the steering wheel. You can use cruise control when you exceed approximately 30 km/h (20 mph).

USING CRUISE CONTROL

WARNING



Do not use cruise control in heavy traffic, on twisty roads or when the road surface is slippery.

Switching cruise control on



E75456

Note: The system is ready for you to set a speed.

Setting a speed

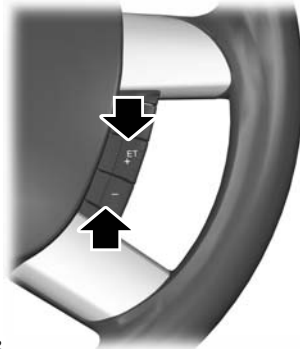

E75452

Press to store and maintain your current speed. The cruise control indicator will illuminate. See **Warning lamps and indicators** (page 64).

Changing the set speed

WARNING



When you are going downhill, your speed may increase above the set speed. The system will not apply the brakes. Change down a gear and press the **SET-** switch to assist the system in maintaining the set speed.

Note: If you accelerate by pressing the accelerator pedal, the set speed will not change. When you release the accelerator pedal, you will return to the speed that you previously set.

Cruise control

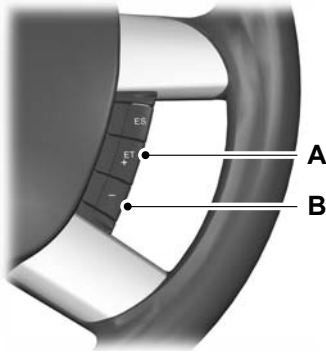

E95393

- A Accelerate
- B Decelerate

Canceling the set speed



E75453

Press the brake pedal or the **RES** switch.

Note: *The system will no longer control your speed. The cruise control indicator will not illuminate but the system will retain the speed that you previously set.*

Resuming the set speed



E75453

The cruise control indicator will illuminate and the system will attempt to resume the speed that you previously set.

Switching cruise control off









E75455

The system will not retain the speed that you previously set. The cruise control indicator will not illuminate.

Load carrying

GENERAL INFORMATION

WARNINGS

-  Use load securing straps to an approved standard, e.g. DIN.
-  Make sure that you secure all loose items properly.
-  Place luggage and other loads as low and as far forward as possible within the luggage or loadspace.
-  Do not drive with the tailgate or rear door open. Exhaust fumes may enter the vehicle.
-  Do not exceed the maximum front and rear axle loads for your vehicle. See **Vehicle identification** (page 170).
-  Heavy loads, when placed in the passenger compartment, should be on folded rear seats as shown. See **Rear seats** (page 94).

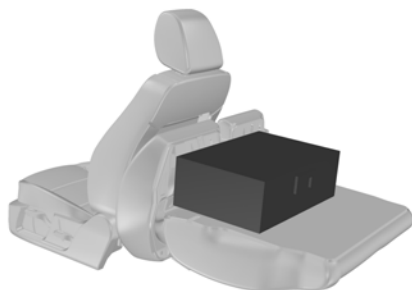



E97377

LUGGAGE ANCHOR POINTS



E86913

CAUTIONS

-  Do not allow items to contact the rear windows.
-  Do not use any abrasive materials to clean the interior of the rear windows.
-  Do not install stickers or labels to the interior of the rear windows.

LUGGAGE COVERS

WARNING

-  Do not place objects on the luggage cover.

Load carrying

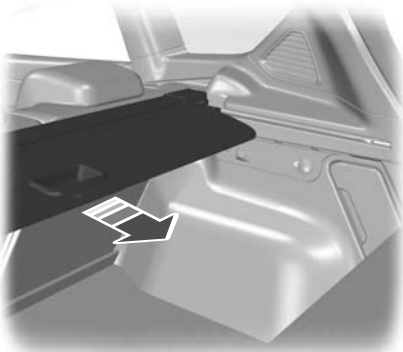

E112571

Pull out the cover until it locks.

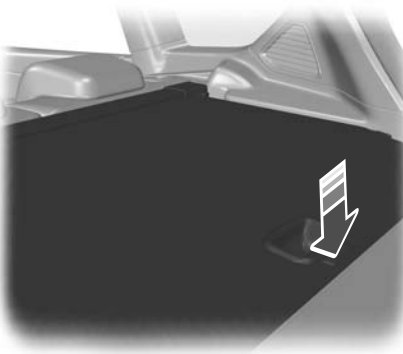

E112572

Release it from the retaining points by pressing below the handle. Let it roll slowly back into the case.

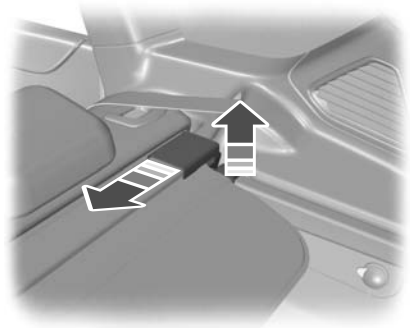

E112588

To remove or install the cover, push either end of the case inwards.

Stowing the luggage cover - vehicles with tyre repair kit

Space is provided under the luggage compartment floor.

REAR UNDER FLOOR STORAGE

WARNING



When you are using a child seat with a support leg, make sure that you install the foam spacer correctly inside the storage compartment and that you position the cover correctly.

Load carrying

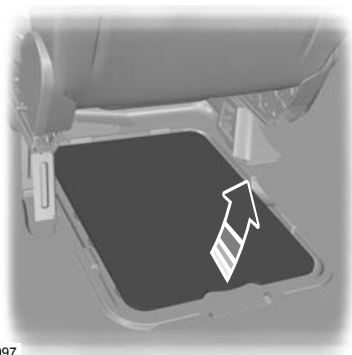



E78097

ROOF RACKS AND LOAD CARRIERS

Roof rack

WARNINGS

 If you use a roof rack, the fuel consumption of your vehicle will be higher and you may experience different driving characteristics.

 Read and follow the manufacturer's instructions when you are fitting a roof rack.

CAUTION

 Do not exceed the maximum permissible roof load of 75 kilograms (165 pounds) (including the roof rack).

Check the security of the roof rack and tighten its fittings as follows:

- before starting
- after driving 50 kilometres (30 miles)
- at 1 000 kilometres (600 miles) intervals.

Installing the crossbars

WARNING

 Distribute the load evenly over the loading area and keep the centre of gravity as low as possible. Secure the load well to prevent it from slipping. Never place any loads directly onto the roof surface.

CAUTION

 Remove the crossbars before entering an automatic car wash.

Note: The side mounting tracks are designed such that crossbars (for bicycle carriers, ski carriers etc.) from the Ford accessories range can be fitted.

Note: Before installing the crossbars, clean the side mounting tracks with water and a sponge.

Note: Position the crossbars as shown.

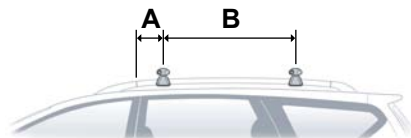

E98206

- | | |
|---|--------|
| A | 110 mm |
| B | 700 mm |

Load carrying

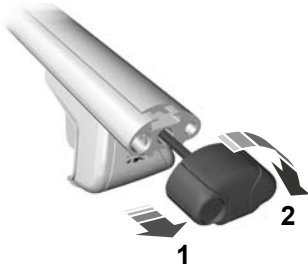

E98207

1. Pull the handle out.
2. Turn the handle clockwise to bring the crossbar in contact with the rail.

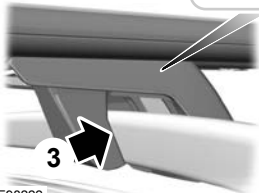

E98222

Note: Make sure there is no gap between crossbar and rail (A).

3. Turn the handle a minimum of 3.5 revolutions.



E98208

4. Push the handle in. Turn the key clockwise to lock.
5. Remove the key.

Accessing the T-notch

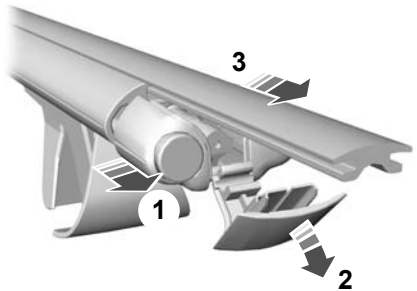

E98209

1. Pull the handle out.
2. Lower the cover.
3. Remove the sliding bar.

Cycle carrier

CAUTION

 The cycle carrier fixtures must only be fitted to the main luggage compartment lid.

Load carrying



E99775

Towing

TOWING A TRAILER

WARNINGS



Do not exceed the maximum gross train weight stated on the vehicle identification plate. See **Vehicle identification** (page 170).



Do not exceed 100 km/h (62 mph).



The rear tyre pressures must be increased by 0.2 bar (3 psi) above specification. See **Technical specifications** (page 168).

CAUTIONS



Do not exceed the maximum permissible nose weight, i.e. vertical weight on the tow ball, of 100 kilogrammes (220 pounds) for vehicles with a diesel engine, or 105 kilogrammes (231 pounds) for vehicles with a petrol engine.



We recommend you purchase a towing kit from your dealer. Failure to do so may result in damage to the engine.

Note: *Not all vehicles are suitable or approved to have tow bars fitted. Check with your dealer first.*

Place loads as low and central to the axle(s) of the trailer as possible. If you are towing with an unladen vehicle, the load in the trailer should be placed toward the nose, within the maximum nose load, as this gives the best stability.

The stability of the vehicle to trailer combination is very much dependant on the quality of the trailer.

In high altitude regions above 1 000 metres (3 281 feet), the stipulated maximum permitted gross train weight must be reduced by 10% for every additional 1 000 metres (3 281 feet).

Steep gradients

WARNING



The overrun brake on a trailer is not controlled by ABS.

Change down a gear before you reach a steep downhill gradient.

DETACHABLE TOW BALL

WARNINGS



When not in use, always transport the tow ball arm securely fastened in the luggage compartment.



Take special care when fitting the tow ball arm as the safety of the vehicle and the trailer depends on this.



Do not use any tools for mounting or dismantling the tow ball arm. Do not modify the trailer coupling. Do not disassemble or repair the tow ball arm.

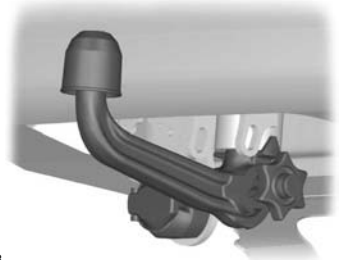

E71328

Towing

Unlocking the tow ball arm mechanism

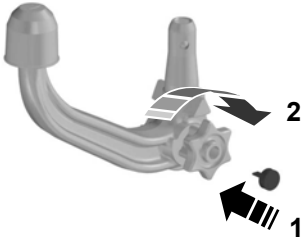

E99477

1. Detach the keyhole protective cap.
2. Insert the key and turn it anti-clockwise to unlock (1).
3. Hold the tow ball arm. Pull the handwheel out and turn it clockwise until it clicks (2).
4. The **red** mark on the handwheel must align with the **white** mark on the tow ball.
5. Release the handwheel. The tow ball arm is unlocked.

Inserting the tow ball arm

WARNING



The tow ball arm may only be inserted when completely unlocked.

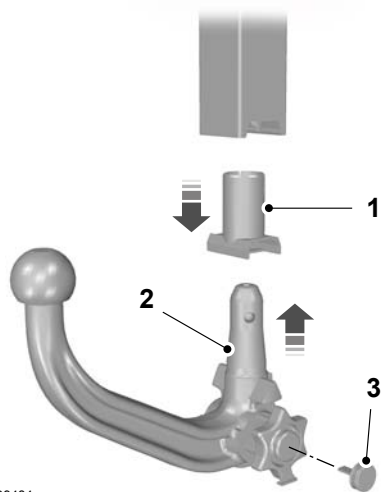

E99484

1. Pull out the plug (1).
2. Insert the tow ball arm vertically and press it upwards until it engages (2). Do not hold your hand near the handwheel.
3. The **green** mark on the handwheel must align with the **white** dot on the tow ball.
4. To lock, turn the key clockwise and remove the key (3).
5. Attach the keyhole protective cap.

Towing

Driving with a trailer

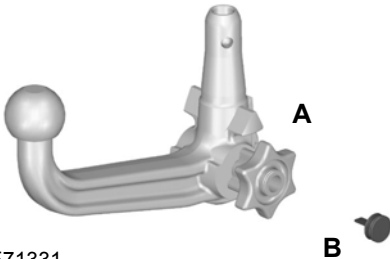

E71331

WARNING



If any of the below conditions cannot be met, do not use the tow bar and have it checked by a properly trained technician.

Before starting your journey, make sure that the tow ball arm is properly locked. Check:

- The **green** mark on the handwheel is aligned with the **white** dot on the tow ball arm.
- the handwheel (**A**) is correctly fitted to the tow ball arm.
- you have removed the key (**B**).
- the tow ball arm is securely positioned. It must not move when jerked.

Removing the tow ball arm

WARNING



Never unlock the tow ball arm with the trailer attached.

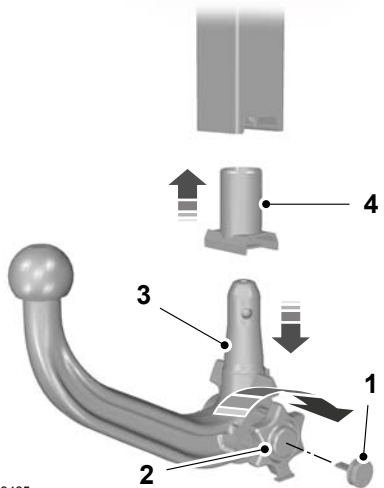

E99485

1. Unhitch the trailer.
2. Detach the keyhole protective cap.
3. Insert the key and turn it anti-clockwise to unlock (1).
4. Hold the tow ball arm. Pull the handwheel out, turn it clockwise against the stop (2) and remove the tow ball arm (3).
5. Release the handwheel.

When unlocked in this way, the tow ball arm can be reinserted at any time.

Insert the plug into its seat (4).

Maintenance

WARNING



Remove the tow ball arm and protect the seat with the plug before steam cleaning your vehicle.

Towing

Keep the system clean. Periodically lubricate bearings, sliding surfaces, and locking balls with resin-free grease or oil and the lock with graphite.

Keep a note of the key number. In case of loss, replacement keys are available from the manufacturer by stating the three digit key number.

Driving hints

RUNNING-IN

Tyres

WARNING



New tyres need to be run-in for approximately 500 kilometres (300 miles). During this time, you may experience different driving characteristics.

Brakes and clutch

WARNING



Avoid heavy use of the brakes and clutch if possible for the first 150 kilometres (100 miles) in town and for the first 1 500 kilometres (1 000 miles) on motorways.

Engine

CAUTION



Avoid driving too fast during the first 1 500 kilometres (1 000 miles). Vary your speed frequently and change up through the gears early. Do not labour the engine.

COLD WEATHER PRECAUTIONS

The functional operation of some components and systems can be affected at temperatures below -30°C (-22°F).

DRIVING THROUGH WATER

Driving through water

CAUTIONS



Drive through water in an emergency only, and not as part of normal driving.



Engine damage can occur if water enters the air filter.

In an emergency, the vehicle can be driven through water to a maximum depth of 200 mm and at a maximum speed of 10 km/h (6 mph). Extra caution should be exercised when driving through flowing water.

When driving in water, maintain a low speed and do not stop the vehicle. After driving through water, and as soon as it is safe to do so:

- Depress the brake pedal lightly and check that full brake function is achieved.
- Check that the horn works.
- Check that the vehicle's lights are fully operational.
- Check the power assistance of the steering system.

Emergency equipment

FIRST AID KIT

Space is provided in the under floor storage compartment. See **Rear under floor storage** (page 123).

WARNING TRIANGLE

Space is provided in the under floor storage compartment. See **Rear under floor storage** (page 123).

Status after a collision

FUEL CUT-OFF SWITCH

Vehicles with a Duratec engine



- Turn the ignition switch to position **II**. After a few seconds return the key to position **I**.
- Make a further check for leaks in the fuel system.

E72531

The fuel supply may be cut off as a result of an accident or sudden vibrations (e.g. collision when parking).

The switch is located in the side panel in front of the driver's door.

Resetting the switch

WARNING



Do not reset the fuel cut-off switch if you see or smell leaking fuel.

- Turn the ignition switch to position **O**.
- Check fuel system for leaks.
- If no fuel leak is apparent, reset the switch by pushing in the button (see illustration).

Fuses

FUSE BOX LOCATIONS

Engine compartment fuse box

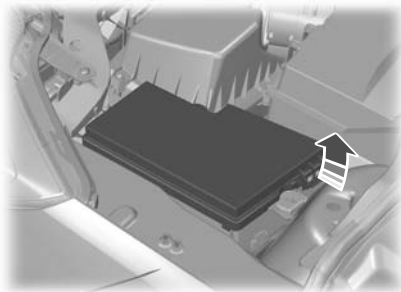

E78332

Passenger compartment fuse box

1. Remove the screws in the instrument panel trim underneath the glove compartment and lower the trim panel.
2. Loosen the screws.
3. Lower the fuse box and pull it towards you.

Install in the reverse order.

CHANGING A FUSE

WARNINGS

 Do not modify the electrical system of your vehicle in any way. Have repairs to the electrical system and the replacement of relays and high current fuses carried out by properly trained technicians.

 Switch the ignition and all electrical equipment off before touching or attempting to change a fuse.

CAUTION

 Fit a replacement fuse with the same rating as the one you have removed.

Note: You can identify a blown fuse by a break in the filament.

Note: All fuses, except high current fuses are a push fit.

Note: A fuse puller is located in the lid of the engine compartment fuse box.

Fuses

FUSE SPECIFICATION CHART

Engine compartment fuse box



E79716

Fuse	Ampere rating	Circuits protected
1	40	Cooling fan
2	80	Power steering
3	60	Passenger junction box supply 1
4	60	Passenger junction box supply 2
5	80	PTC heater
6	60	Glow plugs (diesel only)
7	30	ESP pump
8	20	ESP valves
9	20	Powertrain control module
10	30	Climate control blower
11	20	Ignition switch

Fuses

Fuse	Ampere rating	Circuits protected
12	40	Ignition relay 15l
13	20	Starter solenoid
14	40	Heated windscreen, right-hand side
15	-	Not used
16	40	Heated windscreen, left-hand side
17	-	Not used
18	30	Power converter
19	10	ESP module
20	15	Horn
21	20	Auxiliary heater
22	10	Power steering module
23	30	Headlamp washer
24	15	Diesel fuel heater
25	10	Ignition, relays
26	15	Automatic transmission
27	10	Air conditioning clutch
28	10	Glow plug monitoring (diesel only)
29	10	Dual zone climate control
30	3	Powertrain control module
31	10	Battery sensor smart charging
32	10	Injectors (petrol only)
33	10	Heated oxygen sensors (petrol only)
34	10	Ignition coils, valves
35	10	Powertrain control module, valves, solenoids
36	10	Powertrain control module

Fuses

Passenger compartment fuse box

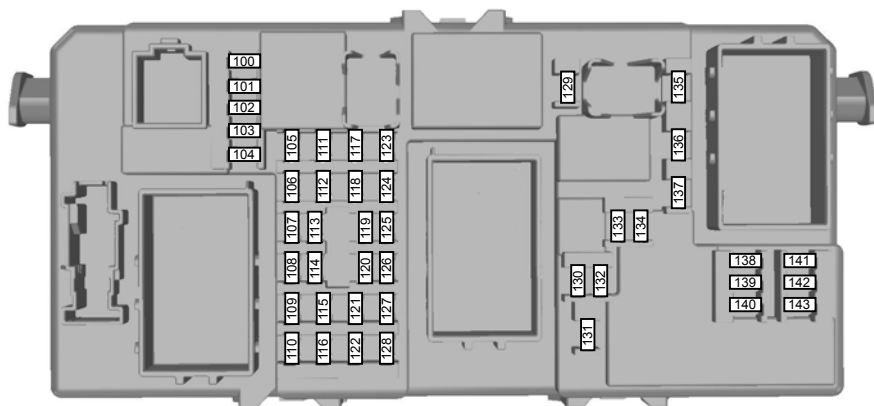

E88709

Fuse	Ampere rating	Circuits protected
100	10	Electronic modules ignition supply
101	20	Driver's electric seat
102	10	Heater control, remote control receiver
103	10	Lighting control battery supply
104	10	Battery saver, interior lamps
105	25	Heated rear window
106	20	Keyless start
107	10	Instrument cluster battery supply, on-board diagnostics
108	7.5	Accessory to cluster (audio and navigation unit)
109	20	Cigar lighter, rear auxiliary power socket

Fuses

Fuse	Ampere rating	Circuits protected
110	10	Daytime running lamps ignition supply to lighting control switch
111	5	Fuel pump (diesel only)
111	15	Fuel pump (petrol only)
112	15	Audio modules battery supply
113	10	Daytime running lamps (parking lamps)
114	10	Instrument cluster ignition supply, engine immobiliser
115	7.5	Lighting control ignition supply
116	20	Fog lamps
117	7.5	Number plate lamps
118	20	Door module, left-hand rear
119	15	Luggage compartment auxiliary power socket
119	25	Luggage compartment auxiliary power socket (vehicles with trailer tow module)
120	20	Door module, right-hand rear
121	20	Heated front seats
122	10	Airbag module
123	7.5	Heated exterior mirrors
124	7.5	Parking lamps, side lamps, tail lamps (left-hand side)
125	7.5	Parking lamps, side lamps, tail lamps (right-hand side)
126	20	Key free system

Fuses

Fuse	Ampere rating	Circuits protected
127	-	Not used
128	-	Not used
129	20	Windscreen wipers
130	10	AWD module
131	15	Rear window wiper
132	15	Brake lamps
133	25	Central locking relays, passenger door module
134	20	Central locking relays, driver door module
135	20	Daytime running lamps
136	15	Washer pump, heated washer jets
137	10	Battery backup sounder
138	10	Powertrain control module, accelerator pedal, automatic transmission, keyless module IGN monitor
139	10	Main beam right-hand side
140	10	Main beam left-hand side
141	10	Reversing lamp
142	15	Dipped beam, right-hand side
143	15	Dipped beam, left-hand side

Vehicle recovery

TOWING POINTS

Front towing eye

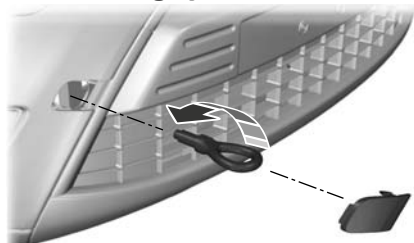

E99490

Rear towing eye

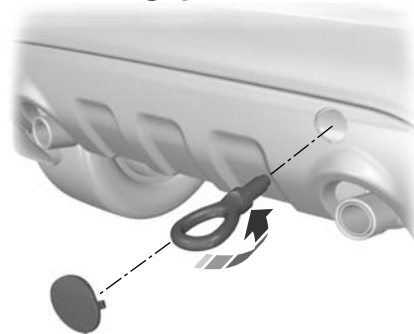

E99491

Note: On vehicles with a tow bar, the towing eye cannot be installed at the rear of the vehicle. Use the tow bar to tow a vehicle.

Towing eye location

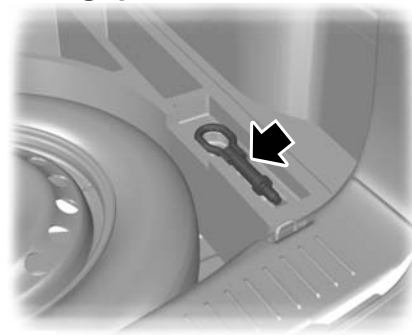

E99468

The screw-in towing eye is located in the luggage compartment next to the spare wheel well.

The towing eye must **always** be carried in the vehicle.

Prise off the cover and install the towing eye.

CAUTION

 The screw-in towing eye has a **left-hand thread**. Turn it **anti-clockwise** to install it.

TOWING THE VEHICLE ON FOUR WHEELS

All vehicles

WARNINGS



 Switch the ignition on when your vehicle is being towed. The steering lock will engage and the direction indicators and brake lamps will not work if you do not.

Vehicle recovery





WARNINGS

 The brake servo and the power steering pump do not operate unless the engine is running. Press the brake pedal harder and allow for increased stopping distances and heavier steering.

CAUTIONS

-  In the event of a mechanical failure of the transmission the drive wheels must be lifted clear of the ground.
 -  Do not tow your vehicle if the ambient temperature is below 0°C (32°F).
-



CAUTIONS

-  Too much tension in the tow rope could cause damage to your vehicle or the vehicle that is towing.
 -  Do not use a rigid tow bar on the front towing eye.
 -  Select neutral when your vehicle is being towed.
 -  For vehicles with AWD, in the event of a breakdown or mechanical failure of the transmission your vehicle must be recovered with either **ALL** wheels on the ground or transported with **ALL** wheels off the ground.
-

Drive off slowly and smoothly without jerking the vehicle that is towing.

Vehicles with automatic transmission

CAUTIONS

-  If a speed of 20 km/h (12 mph) and a distance of 20 kilometres (12 miles) is to be exceeded the drive wheels must be lifted clear of the ground.
-  It is recommended not to tow with the drive wheels on the ground. However, if it is required to move the vehicle from a dangerous location, do not tow your vehicle faster than 20 km/h (12 mph) or further than 20 kilometres (12 miles).
-  Do not tow your vehicle backwards.

Maintenance

GENERAL INFORMATION

Have your vehicle serviced regularly to help maintain its roadworthiness and resale value. There is a large network of Ford Authorised Repairers that are there to help you with their professional servicing expertise. We believe that their specially trained technicians are best qualified to service your vehicle properly and expertly. They are supported by a wide range of highly specialised tools developed specifically for servicing your vehicle.

In addition to regular servicing, we recommend that you carry out the following additional checks.

WARNINGS



Switch the ignition off before touching or attempting adjustment of any kind.



Do not touch the electronic ignition system parts after you have switched the ignition on or when the engine is running. The system operates at high voltage.



Keep your hands and clothing clear of the engine cooling fan. Under certain conditions, the fan may continue to run for several minutes after you have switched the engine off.

CAUTION



When carrying out maintenance checks, make sure that filler caps are fitted securely.

Daily checks

- Exterior lamps.
- Interior lamps.
- Warning lamps and indicators.

Check when refuelling

- Engine oil level. See **Engine oil check** (page 147).
- Brake fluid level. See **Brake and clutch fluid check** (page 149).
- Washer fluid level. See **Washer fluid check** (page 149).
- Tyre pressures (when cold). See **Technical specifications** (page 168).
- Tyre condition. See **Tyre care** (page 166).

Monthly checks

- Engine coolant level (engine cold). See **Engine coolant check** (page 148).
- Pipes, hoses and reservoirs for leaks.
- Power steering fluid level. See **Power steering fluid check** (page 149).
- Air conditioning operation.
- Parking brake operation.
- Horn operation.
- Tightness of wheel nuts. See **Technical specifications** (page 168).

OPENING AND CLOSING THE BONNET

Opening the bonnet

WARNING



To prevent damage to, or loss of the key, remove the key immediately after opening and swivel the Ford badge back.

Note: *On vehicles with keyless entry, use the spare key. See **Keyless entry** (page 31).*

Maintenance

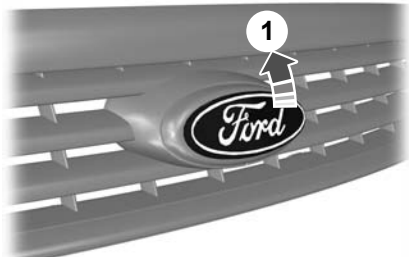

E78141

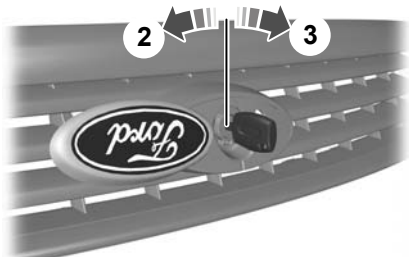

E78142

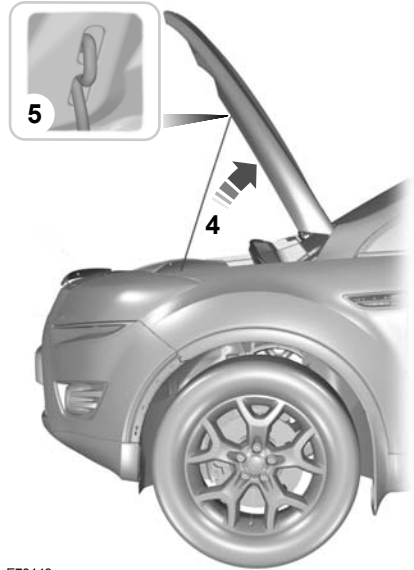

E78143

Closing the bonnet

Note: Make sure that the bonnet is closed properly.

Lower the bonnet and allow it to drop from under its own weight for the last 20 - 30 centimetres (8 - 12 inches).

Maintenance

ENGINE COMPARTMENT OVERVIEW - 2.5L DURATEC (VI5)

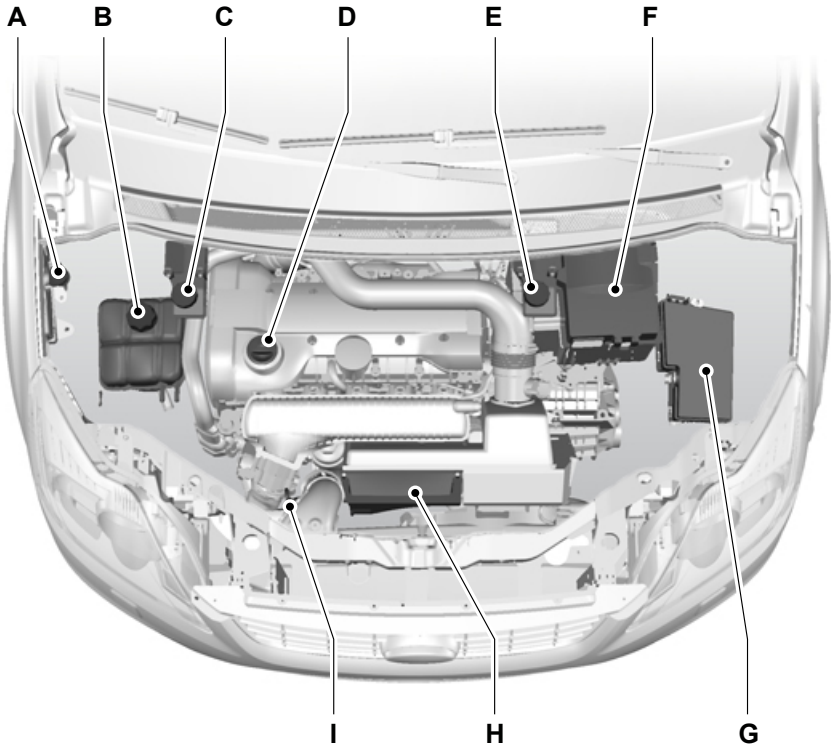

E78890

- A Screen washer fluid reservoir^{*}: See **Washer fluid check** (page 149).
- B Engine coolant reservoir^{*}: See **Engine coolant check** (page 148).
- C Brake and clutch fluid reservoir (right-hand drive)^{*}: See **Brake and clutch fluid check** (page 149).
- D Engine oil filler cap^{*}: See **Engine oil check** (page 147).
- E Brake and clutch fluid reservoir (left-hand drive)^{*}: See **Brake and clutch fluid check** (page 149).
- F Battery: See **Vehicle battery** (page 154).

Maintenance

- G Engine compartment fuse box: See **Fuses** (page 134).
- H Air cleaner: No maintenance necessary.
- I Engine oil dipstick*: See **Engine oil check** (page 147).

*For easy identification, filler caps and the engine oil dipstick are marked in colour.

ENGINE COMPARTMENT OVERVIEW - 2.0L DURATORQ-TDCI (DW) DIESEL

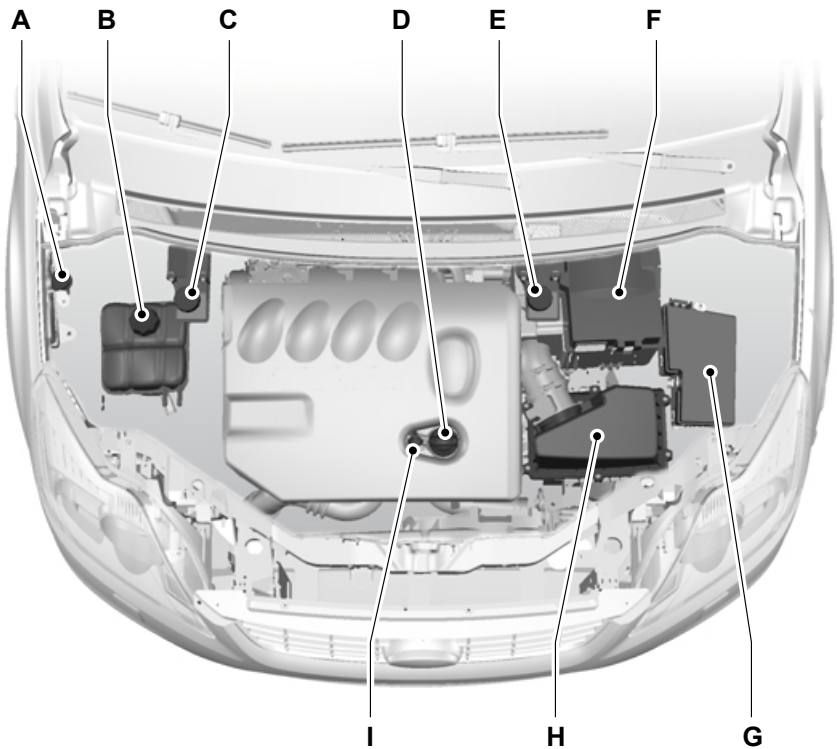

E78893

Maintenance

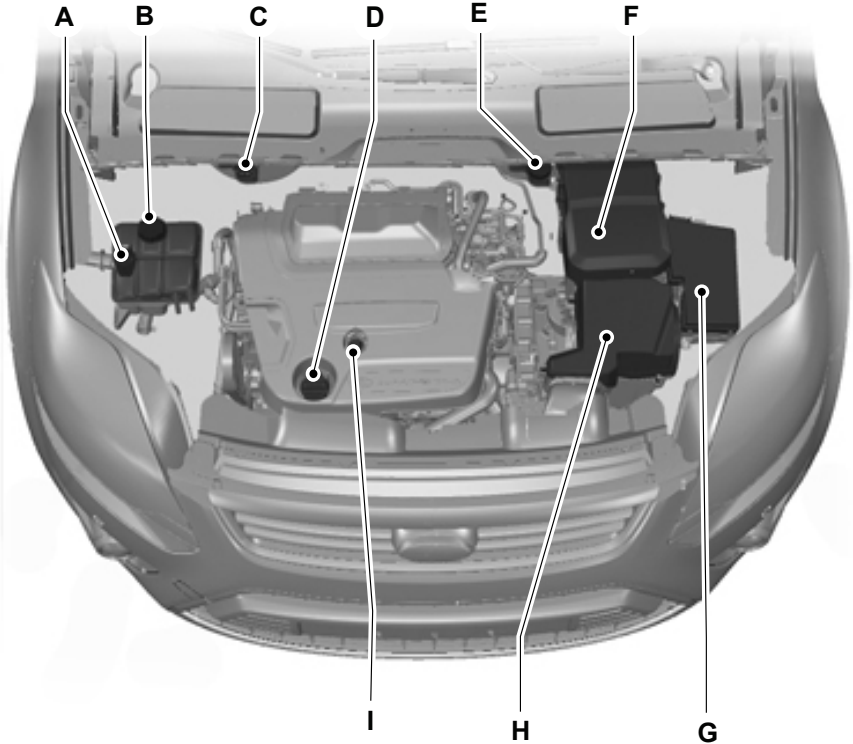

E125377

- A Screen washer fluid reservoir^{*}: See **Washer fluid check** (page 149).
- B Engine coolant reservoir^{*}: See **Engine coolant check** (page 148).
- C Brake and clutch fluid reservoir (right-hand drive)^{*}: See **Brake and clutch fluid check** (page 149).
- D Engine oil filler cap^{*}: See **Engine oil check** (page 147).
- E Brake and clutch fluid reservoir (left-hand drive)^{*}: See **Brake and clutch fluid check** (page 149).
- F Battery: See **Vehicle battery** (page 154).
- G Engine compartment fuse box: See **Fuses** (page 134).

Maintenance

H Air cleaner: No maintenance necessary.

I Engine oil dipstick*: See **Engine oil check** (page 147).

*For easy identification, filler caps and the engine oil dipstick are marked in colour.

ENGINE OIL DIPSTICK - 2.5L DURATEC (V15)

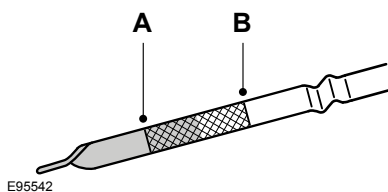

A MIN
B MAX

ENGINE OIL DIPSTICK - 2.0L DURATORQ-TDCI (DW) DIESEL

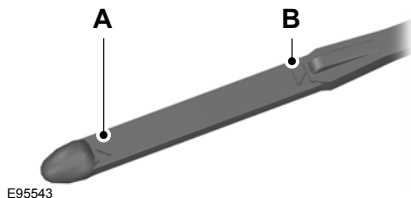

A MIN
B MAX

ENGINE OIL CHECK

CAUTION

! Do not use oil additives or other engine treatments. Under certain conditions, they could damage the engine.

Note: The oil consumption of new engines reaches its normal level after approximately 5 000 kilometres (3 000 miles).

Checking the oil level

CAUTION

! Make sure that the level is between the **MIN** and the **MAX** marks.

Note: Check the level before starting the engine.

Note: Make sure that your vehicle is on level ground.

Note: Oil expands when it is hot. The level may therefore extend a few millimetres beyond the **MAX** mark.

Remove the dipstick and wipe it with a clean, lint free cloth. Replace the dipstick and remove it again to check the oil level.

If the level is at the **MIN** mark, top up immediately.

Maintenance

Topping up

WARNINGS

 Only top up when the engine is cold. If the engine is hot, wait 10 minutes for the engine to cool down.

 Do not remove the filler cap when the engine is running.

Remove the filler cap.

CAUTION

 Do not top up further than the **MAX** mark.

Top up with fluid that meets the Ford specification. See **Technical specifications** (page 150).

ENGINE COOLANT CHECK

Checking the coolant level

WARNING

 Do not allow the fluid to touch your skin or eyes. If this happens, rinse the affected areas immediately with plenty of water and contact your doctor.

CAUTION

 Make sure that the level is between the **MIN** and the **MAX** marks.

Note: *Coolant expands when it is hot. The level may therefore extend beyond the **MAX** mark.*

If the level is at the **MIN** mark, top up immediately.

Topping up

WARNINGS

 Only top up when the engine is cold. If the engine is hot, wait 10 minutes for the engine to cool down.

 Do not remove the filler cap when the engine is running.

 Do not remove the filler cap when the engine is hot. Wait for the engine to cool down.

 Undiluted coolant is flammable and may ignite if spilt on a hot exhaust.

CAUTIONS

 In an emergency, you can add just water to the cooling system to reach a vehicle service station. The system must then be drained and refilled with a 50/50 mixture of coolant and water. Have the system checked by a properly trained technician as soon as possible.

 Increased dilution of the coolant can cause engine damage from corrosion, overheating or freezing.

Unscrew the cap **slowly**. Any pressure will escape slowly as you unscrew the cap.

CAUTION

 Do not top up further than the **MAX** mark.

Top up with a 50/50 mixture of coolant and water using fluid that meets the Ford specification. See **Technical specifications** (page 150).

Maintenance

BRAKE AND CLUTCH FLUID CHECK

WARNINGS



Do not allow the fluid to touch your skin or eyes. If this happens, rinse the affected areas immediately with plenty of water and contact your doctor.



If the level is at the **MIN** mark, have the system checked by a properly trained technician as soon as possible.

Note: *The brake and the clutch systems are supplied from the same reservoir.*

Top up with fluid that meets the Ford specification. See **Technical specifications** (page 150).

POWER STEERING FLUID CHECK

WARNING



Do not allow the fluid to touch your skin or eyes. If this happens, rinse the affected areas immediately with plenty of water and contact your doctor.

CAUTION



Make sure that the level is between the **MIN** and the **MAX** marks.

If the level is at the **MIN** mark, top up immediately.

Topping up

Remove the filler cap.

CAUTION



Do not top up further than the **MAX** mark.

Top up with fluid that meets the Ford specification. See **Technical specifications** (page 150).

WASHER FLUID CHECK

The front and rear washer systems are supplied from the same reservoir.

Maintenance

TECHNICAL SPECIFICATIONS

Vehicle fluids

Item	Recommended fluid	Specification
Engine oil	Castrol Engine Oil*	WSS-M2C913-C
Power steering fluid	Ford or Motorcraft Power Steering Fluid	WSS-M2C204-A2
Coolant	Motorcraft SuperPlus Anti-freeze	WSS-M97B44-D
Brake fluid	Ford or Motorcraft Super DOT 4 Brake Fluid	ESD-M6C57-A

* Providing it meets the specification defined by **WSS-M2C913-C**, you can also use Ford Engine Oil or an alternative engine oil.

Note: If you operate your vehicle in temperatures below -20°C (-4°F), you must not use **SAE 10W-40** engine oil.

Topping up the oil: If you are unable to find an oil that meets the specification defined by **WSS-M2C913-C**, you must use **SAE 5W-30** (preferred), **SAE 5W-40** (except vehicles with E85 fuel) or **SAE 10W-40** that meets the specification defined by either **ACEA A1/B1** (preferred) or **ACEA A3/B3**. Using these oils can result in longer engine cranking periods, reduced engine performance, reduced fuel economy and increased emission levels.

Castrol engine oil recommended.



Capacities

Variant	Item	Capacity in litres (gallons)
All	Power assisted steering fluid	MAX mark
All	Engine cooling system	approx. 8.6 (1.9)
All	Windscreen washer system	4.0 (0.9)
2.0L Duratorq-TDCi	Fuel tank	65 (14.3)
2.5L Duratec	Fuel tank	66 (14.5)

Maintenance

Variant	Item	Capacity in litres (gallons)
2.0L Duratorq-TDCi	Engine oil - with filter	5.5 (1.2)
2.0L Duratorq-TDCi	Engine oil - without filter	5.0 (1.1)
2.5L Duratec	Engine oil - with filter	5.8 (1.3)
2.5L Duratec	Engine oil - without filter	5.5 (1.2)

Vehicle care

CLEANING THE EXTERIOR

WARNING



If you use a car wash with a waxing cycle, make sure that you remove the wax from the windscreen.

CAUTIONS



Prior to using a car wash facility check the suitability of it for your vehicle.



Some car wash installations use water at high pressure. This could damage certain parts of your vehicle.



Remove the aerial before using an automatic car wash.



Switch the heater blower off to prevent contamination of the fresh air filter.

We recommend that you wash your vehicle with a sponge and lukewarm water containing a car shampoo.

Cleaning the headlamps

CAUTIONS



Do not scrape the headlamp lenses or use abrasives, alcoholic solvents or chemical solvents to clean them.



Do not wipe the headlamps when they are dry.

Cleaning the rear window

CAUTION



Do not scrape the inside of the rear window or use abrasives or chemical solvents to clean it.

Use a clean, lint free cloth or a damp chamois leather to clean the inside of the rear window.

Cleaning the chrome trim

CAUTION



Do not use abrasives or chemical solvents. Use soapy water.

Body paintwork preservation

CAUTIONS



Do not polish your vehicle in strong sunshine.



Do not allow polish to touch plastic surfaces. It could be difficult to remove.



Do not apply polish to the windscreen or rear window. This could cause the wipers to become noisy and they may not clear the window properly.

We recommend that you wax the paintwork once or twice a year.

CLEANING THE INTERIOR

Seat belts

WARNINGS



Do not use abrasives, or chemical solvents to clean them.



Do not allow moisture to penetrate the seat belt retractor mechanism.

Clean the seat belts with interior cleaner or water applied with a soft sponge. Let the seat belts dry naturally, away from artificial heat.

Instrument cluster screens, LCD screens, radio screens

WARNING



Do not use abrasives, alcoholic solvents or chemical solvents to clean them.

REPAIRING MINOR PAINT DAMAGE

CAUTION



Remove apparently harmless looking substances from the paintwork immediately (e.g. bird droppings, tree resins, insect remains, tar spots, road salt and industrial fall out).

You should repair paintwork damage caused by stones from the road or minor scratches as soon as possible. A choice of products is available from your Ford Dealer. Read and follow the manufacturer's instructions.

Vehicle battery

USING BOOSTER CABLES

CAUTIONS

- ⚠ Connect batteries with only the same nominal voltage.
- ⚠ Always use booster cables with insulated clamps and adequate size cable.
- ⚠ Do not disconnect the battery from the vehicle's electrical system.

To connect the booster cables

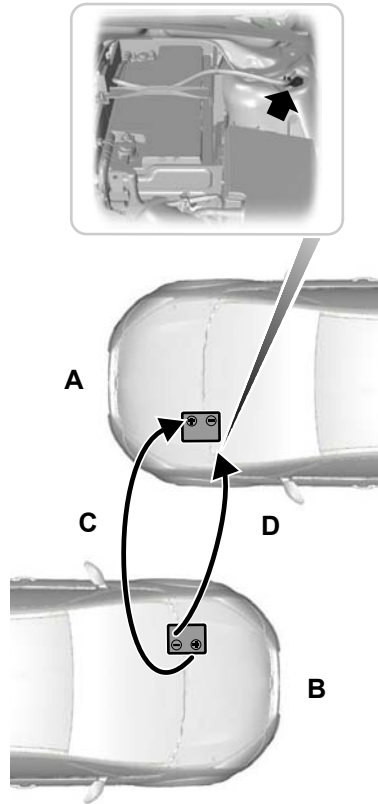



E99387

- A Flat battery vehicle
- B Booster battery vehicle
- C Positive connection cable
- D Negative connection cable

Vehicle battery

1. Position the vehicles so that they do not touch one another.
2. Switch off the engine and any electrical equipment.
3. Connect the positive (+) terminal of vehicle **B** with the positive (+) terminal of vehicle **A** (cable **C**).
4. Connect the negative (-) terminal of vehicle **B** to the ground connection on the left-hand side suspension turret of vehicle **A** (cable **D**).

CAUTIONS

-  **Do not connect to the negative (-) terminal of the flat battery.**
-  Make sure that the cables are clear of any moving parts.

To start the engine

1. Run the engine of vehicle **B** at moderately high speed.
2. Start the engine of vehicle **A**.
3. Run both vehicles for a minimum of three minutes before disconnecting the cables.

CAUTION



-  Do not switch on the headlamps when disconnecting the cables. The peak voltage could blow the bulbs.

Disconnect the cables in the reverse order.

Wheels and tyres

GENERAL INFORMATION

CAUTIONS

-  Use only approved wheel and tyre sizes. Using other sizes could damage the vehicle and will make the National Type Approval invalid.
-  If you change the diameter of the tyres from that fitted at the factory, the speedometer may not display the correct speed. Take the vehicle to your dealer to have the engine management system reprogrammed.

A decal with tyre pressure data is located in the driver's door opening at the B-pillar.

Check and set the tyre pressure at the ambient temperature in which you are intending to drive the vehicle and when the tyres are cold.





CHANGING A ROAD WHEEL

Locking wheel nuts



You can obtain a replacement locking wheel nut key and replacement locking wheel nuts from your dealer using the reference number certificate.

Vehicles with a temporary spare wheel

WARNINGS

-  If the spare wheel differs from the other fitted wheels, these rules must be followed:
-  Do not exceed 80 km/h (50 mph).
-  Drive the shortest possible distances.
-  Do not fit more than one spare wheel on your vehicle at any one time.

WARNINGS

-  Do not use snow chains on this type of wheel.
-  Do not drive through an automatic car wash.
-  Do not carry out any tyre repairs on a temporary spare wheel.



CAUTION

-  The ground clearance of your vehicle will be reduced. Take care when parking next to a kerb.

Note: *Your vehicle may exhibit some unusual driving characteristics.*

Vehicle jack

WARNINGS

-  The vehicle jack supplied with your vehicle should only be used when changing a wheel in emergency situations.
-  Before using the vehicle jack, check that it is not damaged or deformed and that the thread is lubricated and free from foreign matter.
-  Never place anything between the jack and the ground, or the jack and the vehicle.

Note: *Vehicles with a tyre repair kit or run flat tyres are not equipped with a vehicle jack or a wheel brace.*

It is recommended to use a workshop type hydraulic jack for changing between summer and winter tyres.

Note: *Use a jack with a minimum lifting capacity of 1.5 tonnes and a lifting plate with a minimum diameter of 80 millimetres (3.1 inches).*

Wheels and tyres

Vehicles without tyre repair kit or run flat tyres

Your vehicle jack, wheel brace, screw-in towing eye and wheel trim remover are located in the spare wheel well.

Jacking and lifting points

CAUTION

! Use only the specified jacking points. If you use other positions, you may damage the body, steering, suspension, engine, braking system or the fuel lines.

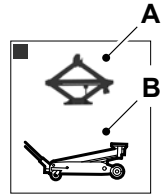
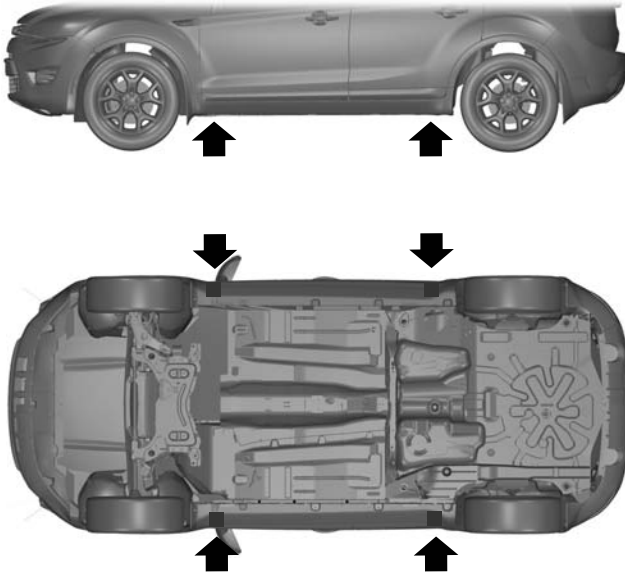

E92658

- A Emergency use only
- B Maintenance

Wheels and tyres

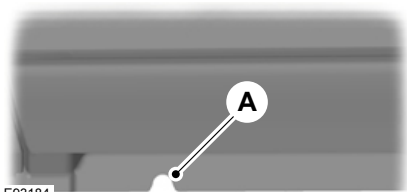

E93184

Indentations in the sills **A** show the location of the jacking points.

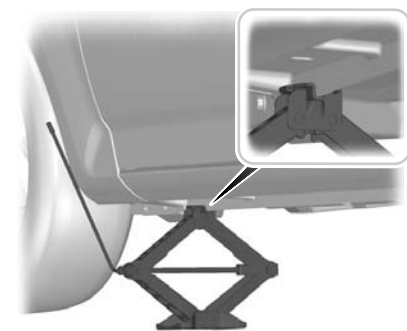

E92932



E93020

Vehicles with side skirts



E95345

Assembling the wheel brace

Type one

WARNING



When returning the wheel brace extension to its original position, take care not to get your fingers caught.

Note: Make sure that the wheel brace is fully extended.



E122546

Extend the wheel brace.

Type two

CAUTION



The screw-in towing eye has a **left-hand thread**. Turn it anti-clockwise to install it. Make sure that the towing eye is fully tightened.

Wheels and tyres

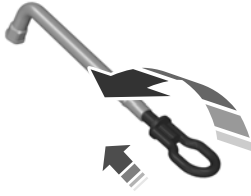

E122502

Insert the screw-in towing eye into the wheel brace.

Removing the wheel trim

Type one

Insert the flat end of the wheel brace between the rim and the trim and carefully remove the trim.

Type two

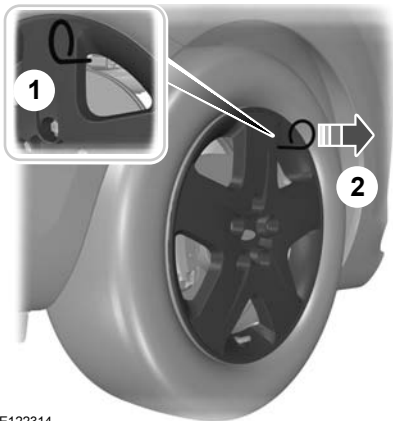











E122314

1. Insert the wheel trim remover.
2. Remove the wheel trim.

Note: Make sure that you pull the wheel trim remover at right angles to the trim.

Removing a road wheel

WARNINGS

-  Park your vehicle in such a position that neither the traffic nor you are hindered or endangered.
-  Set up a warning triangle.
-  Make sure that the vehicle is on firm, level ground with the wheels pointing straight ahead.
-  Switch off the ignition and apply the parking brake.
-  If your vehicle has a manual transmission, select first or reverse gear. If it has an automatic transmission, select park.
-  Have the passengers leave the vehicle.
-  Secure the diagonally opposite wheel with an appropriate block or wheel chock.
-  Make sure that the arrows on directional tyres point in the direction of rotation when the vehicle is moving forwards. If you have to fit a spare wheel with the arrows pointing in the opposite direction, have the tyre refitted in the correct direction by a properly trained technician.
-  Do not work underneath the vehicle when it is supported only by a jack.
-  Make sure that the jack is vertical to the jacking point and the base is flat on the ground.

CAUTION

-  Do not lay alloy wheels face down on the ground, this will damage the paint.

Wheels and tyres

Note: The spare wheel is located under the floor cover in the luggage compartment.

1. Install the locking wheel nut key.

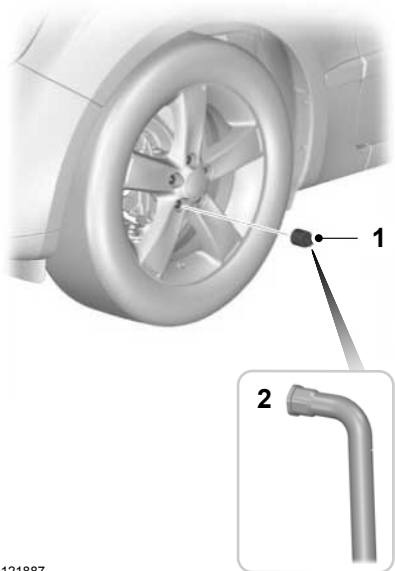

E121887

2. Slacken the wheel nuts.
3. Jack up the vehicle until the tyre is clear of the ground.
4. Remove the wheel nuts and the wheel.

Installing a road wheel

WARNINGS

! Use only approved wheel and tyre sizes. Using other sizes could damage the vehicle and will make the National Type Approval invalid. See **Technical specifications** (page 168).

WARNINGS

! Do not fit run flat tyres on vehicles that were not originally fitted with them. Please contact your dealer for more details regarding compatibility.

CAUTION

! Do not install alloy wheels using wheel nuts designed for use with steel wheels.

Note: Make sure the wheel and hub contact surfaces are free from foreign matter.

Note: Make sure that the cones on the wheel nuts are against the wheel.

1. Install the wheel.
2. Install the wheel nuts finger tight.
3. Install the locking wheel nut key.

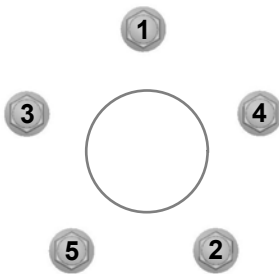

E75442

4. Partially tighten the wheel nuts in the sequence shown.
5. Lower the vehicle and remove the jack.
6. Fully tighten the wheel nuts in the sequence shown. See **Technical specifications** (page 168).

Wheels and tyres

7. Install the wheel trim using the ball of your hand.

WARNING



Have the wheel nuts checked for tightness and the tyre pressure checked as soon as possible.

Note: *If the spare wheel is different in size or construction to the road wheels, have this replaced as soon as possible.*

TYRE REPAIR KIT

Your vehicle is not equipped with a spare tyre, but does include an emergency tyre repair kit that can be used to repair **one** flat tyre.

The tyre repair kit is located in the underfloor storage compartment. See **Storage compartments** (page 98).

General information

WARNINGS



Depending on the type and extent of tyre damage, some tyres can only be partially sealed or not sealed at all. Loss of tyre pressure can affect vehicle handling, leading to loss of vehicle control.



Do not use the tyre repair kit if the tyre has already been damaged as a result of being driven under inflated.



Do not use the tyre repair kit on run flat tyres.



Do not try to seal damage other than that located within the visible tread of the tyre.



Do not try to seal damage to the tyre's sidewall.

The tyre repair kit seals most tyre punctures [with a diameter of up to six millimetres (1/4 inch)] to temporarily restore mobility.

Observe the following rules when using the kit:

- **Drive with caution and avoid making sudden steering or driving manoeuvres**, especially if the vehicle is heavily loaded or you are towing a trailer.
- The kit will provide you with an emergency temporary repair, enabling you to continue your journey to the next vehicle or tyre dealer, or to drive a maximum distance of 200 kilometres (125 miles).
- Do not exceed a **maximum speed of 80 km/h (50 mph)**.
- Keep the kit out of the reach of children.
- Only use the kit when the ambient temperature is between -30°C (-22°F) and $+70^{\circ}\text{C}$ ($+158^{\circ}\text{F}$).

Using the tyre repair kit

WARNINGS



Compressed air can act as an explosive or propellant.



Never leave the tyre repair kit unattended while in use.

CAUTION



Do not keep the compressor operating for more than 10 minutes.



Note: *Use the tyre repair kit only for the vehicle with which it was supplied.*

Wheels and tyres



- Park your vehicle at the roadside so that you do not obstruct the flow of traffic and so that you are able to use the kit without being in danger.
- Apply the parking brake, even if you have parked on a level road, to make sure that the vehicle will not move.
- Do not attempt to remove foreign objects like nails or screws penetrating the tyre.
- Leave the engine running while the kit is in use, but not if the vehicle is in an enclosed or poorly ventilated area (for example, inside a building). In these circumstances, switch the compressor on with the engine turned off.
- Replace the sealant bottle with a new one before the expiry date (see top of bottle) is reached.
- Inform all other users of the vehicle that the tyre has been temporarily sealed with the tyre repair kit and make them aware of the special driving conditions to be observed.

Inflating the tyre

WARNINGS

-  Check the sidewall of the tyre prior to inflation. If there are any cracks, bumps or similar damage, do not attempt to inflate the tyre.
-  Do not stand directly beside the tyre while the compressor is pumping.
-  Watch the sidewall of the tyre. If any cracks, bumps or similar damage appear, turn off the compressor and let the air out by means of the pressure relief valve **B**. Do not continue driving with this tyre.

WARNINGS

-  The sealant contains natural rubber latex. Avoid contact with skin and clothing. If this happens, rinse the affected areas immediately with plenty of water and contact your doctor.
-  If the tyre inflation pressure does not reach 1.8 bar (26 psi) within seven minutes, the tyre may have suffered excessive damage, making a temporary repair impossible. In this case, do not continue driving with this tyre.

CAUTION

-  Screwing the bottle onto the bottle holder will pierce the seal of the bottle. Do not unscrew the bottle from the holder as the sealant will escape.

Wheels and tyres

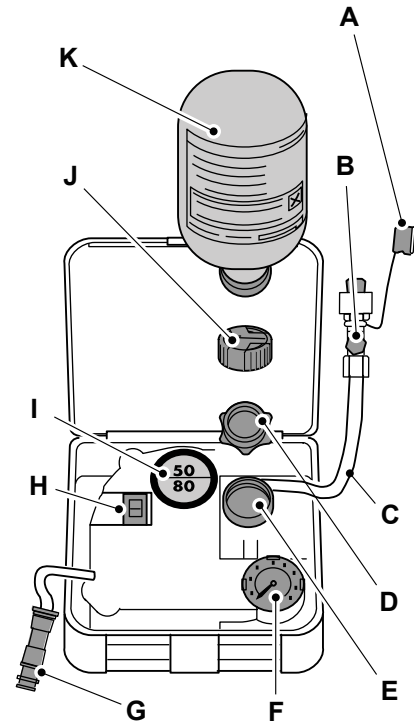

E94973

- A Protective cap
- B Pressure relief valve
- C Hose
- D Orange cap
- E Bottle holder
- F Pressure gauge
- G Power plug with cable
- H Compressor switch
- I Label

- J Bottle lid
- K Sealant bottle

1. Open the lid of the tyre repair kit.
2. Peel off the label **I** showing the maximum permissible speed of 80 km/h (50 mph) from the casing and attach it to the instrument panel in the driver's field of view. Make sure the label does not obscure anything important.
3. Take the hose **C** and the power plug with cable **G** out of the kit.
4. Unscrew the orange cap **D** and the bottle lid **J**.
5. Screw the sealant bottle **K** clockwise into the bottle holder **E** fully tight.
6. Remove the valve cap from the damaged tyre.
7. Detach the protective cap **A** from the hose **C** and screw the hose **C** firmly onto the valve of the damaged tyre.
8. Make sure that the compressor switch **H** is in position **O**.
9. Insert the power plug **G** into the cigar lighter socket or auxiliary power socket. See **Cigar lighter** (page 97). See **Auxiliary power sockets** (page 97).
10. Start the engine.
11. Move the compressor switch **H** to position **1**.
12. Inflate the tyre for no longer than seven minutes to an inflation pressure of minimum 1.8 bar (26 psi) and a maximum of 3.5 bar (51 psi). Move the compressor switch **H** to position **O** and check the current tyre pressure with pressure gauge **F**.
13. Remove the power plug **G** from the cigar lighter socket or auxiliary power socket.

Wheels and tyres

14. Quickly unscrew the hose **C** from the tyre valve and replace the protective cap **A**. Fasten the valve cap again.
15. Leave the sealant bottle **K** in the bottle holder **E**.
16. Make sure the kit, the bottle lid and the orange cap are stored safely, but still easily accessible in the vehicle. The kit will be required again when you check the tyre pressure.
17. Immediately drive approximately three kilometres (two miles) so that the sealant can seal the damaged area.

Note: *When pumping in the sealant through the tyre valve, the pressure may rise up to 6 bar (87 psi) but will drop again after about 30 seconds.*

WARNING



If you experience heavy vibrations, unsteady steering behaviour or noises while driving, reduce your speed and drive with caution to a place where it is safe for you to stop the vehicle. Recheck the tyre and its pressure. If the tyre pressure is less than 1.3 bar (19 psi) or if there are any cracks, bumps or similar damage visible, do not continue driving with this tyre.

Checking the tyre pressure

1. Stop the vehicle after driving approximately three kilometres (two miles). Check, and where necessary, adjust the pressure of the damaged tyre.
2. Attach the kit and read the tyre pressure from the pressure gauge **F**.
3. If the pressure of the sealant-filled tyre is 1.3 bar (19 psi) or more, adjust it to the specified pressure. See **Technical specifications** (page 168).

4. Follow the inflation procedure once again to top up the tyre.
5. Check the tyre pressure again from the pressure gauge **F**. If the tyre pressure is too high, deflate the tyre to the specified pressure using the pressure relief valve **B**.
6. Once you have inflated the tyre to its correct tyre pressure, move the compressor switch **H** to position **O**, remove the power plug **G** from the socket, unscrew the hose **C**, fasten the valve cap and replace the protective cap **A**.
7. Leave the sealant bottle **K** in the bottle holder **E** and store the kit away safely in its original location.
8. Drive to the nearest tyre specialist to get the damaged tyre replaced. Before the tyre is removed from the rim, inform your tyre dealer that the tyre contains sealant. Renew the kit as soon as possible after it has been used once.

Note: *Remember that emergency roadside tyre repair kits only provide temporary mobility. Regulations concerning tyre repair after usage of tyre repair kit may differ from country to country. You should consult a tyre specialist for advice.*

WARNING



Before driving, make sure the tyre is adjusted to the recommended inflation pressure. See **Technical specifications** (page 168). Monitor the tyre pressure until the sealed tyre is replaced.

Empty sealant bottles can be disposed of together with normal household waste. Return remains of sealant to your dealer or dispose of it in compliance with local waste disposal regulations.

Wheels and tyres

RUN FLAT TYRES

Principle of operation

Standard tyre

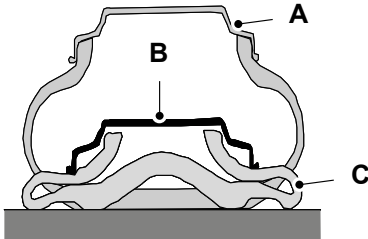

E75207

- A Wheel rim position with correct tyre pressure
- B Wheel rim position with insufficient tyre pressure
- C Tyre

Run flat tyre

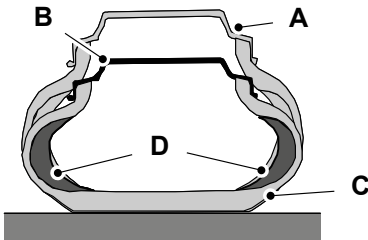

E87667

- A Wheel rim position with correct tyre pressure
- B Wheel rim position with insufficient tyre pressure
- C Tyre
- D Reinforced sidewall

When a standard tyre experiences a drastic loss of inflation pressure, the rim of the wheel brings the full weight of the vehicle to bear on the collapsed sidewalls. You can barely manoeuvre the vehicle and the tyre is destroyed.

Run flat tyres have sturdy, reinforced sidewalls that support the rim should the tyre suffer a loss of inflation pressure.

What to do if a run flat tyre has a puncture



Due to the run-flat properties of these tyres, you may not notice any tyre defect. Your vehicle is equipped with a tyre pressure monitoring system that alerts you to any drop in tyre pressure. See **Technical specifications** (page 168).

In the event of a tyre defect:

- immediately slow down to a maximum speed of 80 km/h (50 mph)
- avoid sudden or erratic braking and steering manoeuvres and be especially careful negotiating bends
- do not drive more than 80 kilometres (50 miles) after the defect is detected
- have the defective tyre replaced as soon as possible.

Replacing run flat tyres

WARNINGS

-  Make sure that the workshop is aware that your vehicle is equipped with special run flat tyres.
-  Never repair or reuse run flat tyres that are damaged or have been driven on run flat.

If a run flat tyre has to be replaced, have the respective wheel rim inspected for any damage.

Wheels and tyres

WARNINGS

 Do not fit a mixture of run flat and standard tyres. In isolated cases, a standard tyre can be temporarily mounted on a vehicle otherwise equipped with run flat tyres. It must be pointed out to the driver that the standard tyre has no runflat properties.

 Do not fit run flat tyres on vehicles that were not originally fitted with them. Please contact your dealer for more details regarding compatibility.

Run flat tyres may be sold and mounted only by specially trained and certified tyre dealers.

TYRE CARE



E70415

To make sure the front and rear tyres of your vehicle wear evenly and last longer, we recommend that you swap the tyres from front to rear and vice versa at regular intervals of between 5 000 and 10 000 km (3 000 and 6 000 miles).

CAUTION

 Do not scrub the sidewalls of the tyres when you are parking.

If you have to mount a kerb, do so slowly and approach it with the wheels at right-angles to the kerb.

Examine the tyres regularly for cuts, foreign objects and uneven wear of the tread. Uneven wear could mean that the wheel alignment is outside specification.

Check the tyre pressures (including the spare) when cold, every two weeks.

USING WINTER TYRES

CAUTION

 Make sure that you use the correct wheel nuts for the type of wheel the winter tyres are fitted to.

If winter tyres are used, make sure that the tyre pressures are correct. See **Technical specifications** (page 168).

USING SNOW CHAINS

WARNINGS

 Do not exceed 40 km/h (25 mph) when using 14 mm (0.6 inch) snow chains or 50 km/h (30 mph) when using 10 mm (0.4 inch) snow chains.

 Do not use snow chains on snow-free roads.

 Only fit snow chains to 235/60 R16 or 215/65 R16 tyres.

CAUTION

 If your vehicle is fitted with wheel trims, remove them before fitting snow chains.

Note: *The ABS will continue to operate normally.*

Only use small link snow chains.

Only use snow chains on the front wheels.

Wheels and tyres

Vehicles with stability control (ESP)

Vehicles with stability control (ESP) may exhibit some unusual driving characteristics which can be avoided by switching the system off. See **Using stability control** (page 113).

TYRE PRESSURE MONITORING SYSTEM

WARNINGS



The system does not relieve you of your responsibility to regularly check the tyre pressures.



The system will only provide a low tyre pressure warning. It will not inflate the tyres.



Do not drive on significantly under-inflated tyres. This may cause the tyres to overheat and fail.

Under-inflation reduces fuel efficiency, tyre tread life and may also affect your ability to drive the vehicle safely.

CAUTIONS



Do not bend or damage the valves when you are inflating the tyres.



Have tyres installed by properly trained technicians.

The Deflation Detection System will alert you if there is a change of air pressure in any tyre. It does this by using the ABS sensors to detect the rolling circumference of the wheels. When the circumference changes, this indicates low pressure in a tyre, a warning message is displayed in the information display and the message indicator will illuminate. See **Information messages** (page 73).

Apart from a too low tyre pressure or a damaged tyre, the following situations can affect the rolling circumference:

- Vehicle load is uneven.
- When using a trailer or travelling up and down an incline.
- Using snow chains.
- Driving on soft surfaces such as snow or mud.

Note: *The system will still function correctly, but there may be an increased detection time.*

If a low pressure warning message is displayed in the information display, check the tyre pressures as soon as possible and inflate them to the recommended pressure. See **Technical specifications** (page 168).

If this happens frequently, have the cause determined and rectified as soon as possible.

System reset

Note: *Do not reset the system when the vehicle is moving.*

Note: *You should reset the system following any adjustment to the tyre pressures or any changing of tyres.*

Note: *Turn the ignition on.*

Type 2 instrument cluster

1. Using the multifunction lever, navigate to **'SET' > T. Pres.**
2. Press and hold the **SET/RESET** button until the message **Tyre Pressure set** appears.

Type 3 instrument cluster

1. Using the multifunction lever, navigate to **hold 'SET' to set Tyre Pres.**

Wheels and tyres

2. Press and hold the **SET/RESET** button until the message

Tyre Pressure set appears.

TECHNICAL SPECIFICATIONS

Wheel nut torque

Wheel type	Nm (lb-ft)
All	130 (96)

Tyre pressures (cold tyres)

Up to 80 km/h (50 mph)

Tyre pressures

Variant	Tyre size	Normal load		Full load	
		Front	Rear	Front	Rear
		bar (lbf/in ²)	bar (lbf/in ²)	bar (lbf/in ²)	bar (lbf/in ²)
All	T135/90 R17	4.2 (61)	4.2 (61)	4.2 (61)	4.2 (61)

Up to 160 km/h (100 mph)

Tyre pressures

Variant	Tyre size	Normal load		Full load	
		Front	Rear	Front	Rear
		bar (lbf/in ²)	bar (lbf/in ²)	bar (lbf/in ²)	bar (lbf/in ²)
All	215/65 R16	2.2 (32)	2.3 (33)	2.4 (35)	2.8 (41)
All	235/60 R16	2.2 (32)	2.3 (33)	2.4 (35)	2.8 (41)
All	235/55 R17	2.2 (32)	2.3 (33)	2.4 (35)	2.8 (41)
All	235/55 RF17	2.2 (32)	2.3 (33)	2.4 (35)	2.8 (41)
All	235/50 R18	2.1 (31)	2.2 (32)	2.4 (35)	2.8 (41)
All	235/45 R19	2.1 (31)	2.2 (32)	2.4 (35)	2.8 (41)

Wheels and tyres

Continuous speed in excess of 160 km/h (100 mph)

Tyre pressures

Variant	Tyre size	Normal load		Full load	
		Front	Rear	Front	Rear
		bar (lbf/in ²)	bar (lbf/in ²)	bar (lbf/in ²)	bar (lbf/in ²)
All	215/65 R16	2.3 (33)	2.3 (33)	2.4 (35)	2.8 (41)
All	235/60 R16	2.3 (33)	2.3 (33)	2.4 (35)	2.8 (41)
All	235/55 R17	2.3 (33)	2.3 (33)	2.4 (35)	2.8 (41)
All	235/55 RF17	2.3 (33)	2.3 (33)	2.4 (35)	2.8 (41)
All	235/50 R18	2.3 (33)	2.3 (33)	2.4 (35)	2.8 (41)
All	235/45 R19	2.3 (33)	2.3 (33)	2.4 (35)	2.8 (41)

Vehicle identification

VEHICLE IDENTIFICATION PLATE

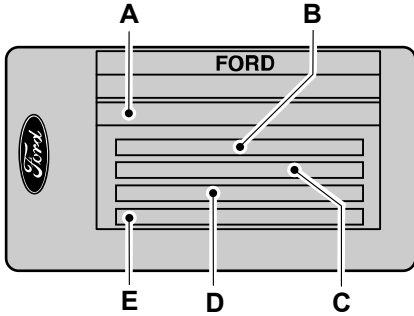

E85610

- A Vehicle identification number
- B Gross vehicle weight
- C Gross train weight
- D Maximum front axle weight
- E Maximum rear axle weight

The vehicle identification number and maximum weights are shown on a plate located on the lock side of the passenger door aperture at the bottom.

VEHICLE IDENTIFICATION NUMBER (VIN)

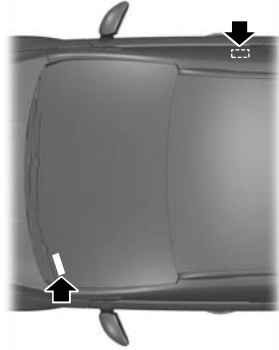

E87496

The vehicle identification number is stamped into the floor panel on the right-hand side, beside the front seat. It is also shown on the left-hand side of the instrument panel.

Technical specifications

TECHNICAL SPECIFICATIONS

Vehicle dimensions

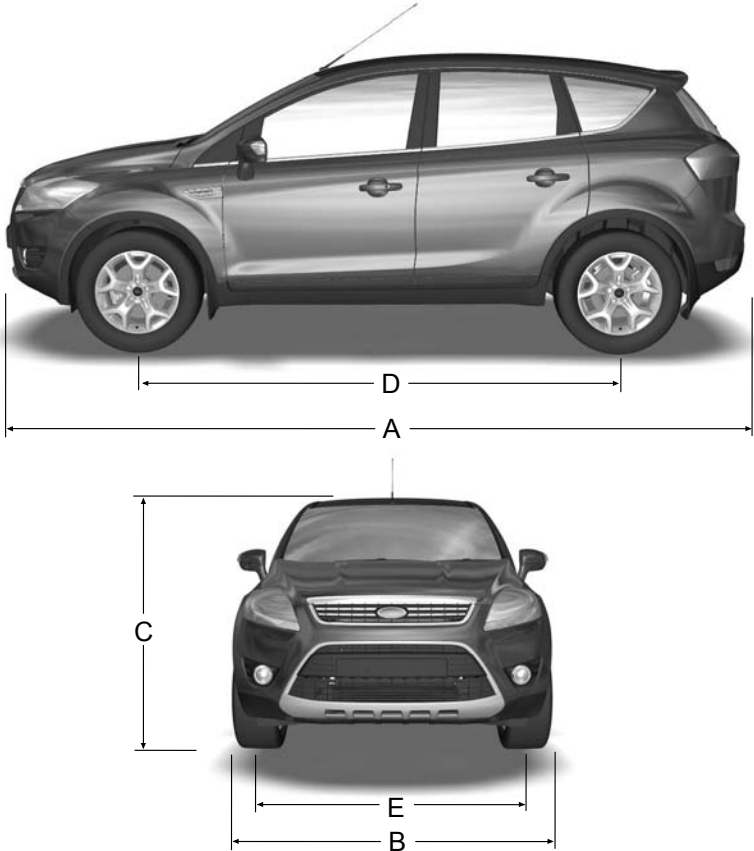

E99435

Item	Dimension description	Dimension in mm (inches)
A	Maximum length	4 443 (174.9)
B	Overall width including exterior mirrors	2 128 (83.8)

Technical specifications

Item	Dimension description	Dimension in mm (inches)
C	Overall height at EC kerb weight without roof bars	1 655 - 1 677 (65.2 - 66)
C	Overall height at EC kerb weight with roof bars	1 687 - 1 710 (66.4 - 67.3)
D	Wheelbase	2 690 (105.9)
E	Front track	1 574 - 1 580 (62 - 62.2)
E	Rear track	1 584 - 1 590 (62.4 - 62.6)

Technical specifications

Towing equipment dimensions

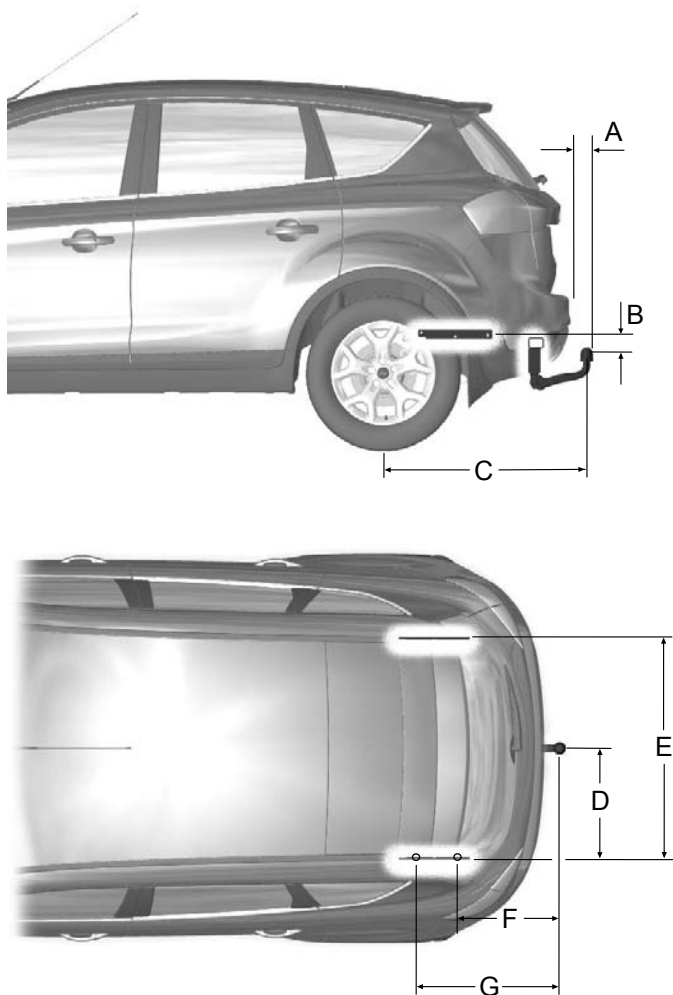

E99436

Technical specifications

Item	Dimension description	Dimension in mm (inches)
A	Bumper – end of tow ball	98 (3.9)
B	Attachment point – centre of tow ball	87 (3.4)
C	Wheel centre – centre of tow ball	918 (36.1)
D	Centre of tow ball – side member	518 (20.4)
E	Outer side of side member	1 031 (40.6)
F	Centre of tow ball – centre of first attachment point	446 (17.6)
G	Centre of tow ball – centre of second attachment point	746 (29.4)

Telephone

GENERAL INFORMATION

CAUTION



Using the system with the engine off will drain the battery.

This section describes the functions and features of the Bluetooth mobile phone hands free system.

The Bluetooth mobile phone part of the system provides interaction with the audio or navigation system and your mobile phone. It allows you to use the audio or navigation system to make and receive calls without having to use your mobile phone.

Compatibility of phones

CAUTION



As no common agreement exists, mobile phone manufacturers are able to implement a variety of profiles in their Bluetooth devices. Because of this, an incompatibility can occur between the phone and hands-free system, which in some cases may significantly degrade the system performance. To avoid this situation, only recommended phones should be used.

Please visit the website www.ford-mobile-connectivity.com for full details.

TELEPHONE SETUP

Phonebook

After start up access to the phonebook list can be delayed for several minutes, depending upon the size.

Phonebook categories

Depending on your phonebook entry, different categories can be displayed in the audio unit.

For example:

M	Mobile
O	Office
H	Home
F	Fax

Note: *Entries may be displayed without a category attachment.*

The category can also be indicated as an icon:



Phone



Mobile



Home



Office



Fax

Making a phone an active phone

When using the system for the first time, no phone is connected to the system.

Bluetooth phone

After bonding a Bluetooth phone to the system, this becomes the active phone. For further information refer to the phone menu.

Telephone

Select the phone from the active phone menu.

Turning the ignition and radio or navigation unit back on again, the last active phone is picked up by the system.

Note: *In some cases the Bluetooth connection must also be confirmed on the phone.*

Bond another Bluetooth phone

Bond a new Bluetooth phone as described in the requirements for a Bluetooth connection.

Phones stored in the system are accessible by using the phone list on the audio unit.

Note: *A maximum of six devices may be bonded. If six Bluetooth devices have already been bonded, one of these has to be debonded in order to bond a new device.*

BLUETOOTH SETUP

Before you can use your telephone with your vehicle it must be bonded to the vehicle telephone system.

Handling of phones

Up to six Bluetooth devices can be bonded to the vehicle system.

Note: *If there is an ongoing call when the phone in use is selected as the new active phone, the call is transferred to the vehicle audio system.*

Note: *Even if connected to the car system, your phone can still be used in the usual way.*

Requirements for Bluetooth connection

The following are required before a Bluetooth phone connection can be made.

1. The Bluetooth feature must be activated on the phone and on the audio unit. Make sure the Bluetooth menu option in the audio unit is set to **ON**. For information on phone settings, refer to your phone user guide.
2. The private mode must not be activated on the Bluetooth phone.
3. Search for audio device.
4. Select **Ford Audio**.
5. Enter the code number shown on the vehicle display using the phone keypad. If no code number is shown on the display, enter the Bluetooth PIN number 0000 using the phone keypad. Now enter the Bluetooth PIN number shown on the vehicle display.

Note: *A phone call will be disconnected if the audio unit is switched off. If the ignition key is turned to the off position the phone call will remain in progress.*

Telephone

TELEPHONE CONTROLS

Remote control

Voice and mode button

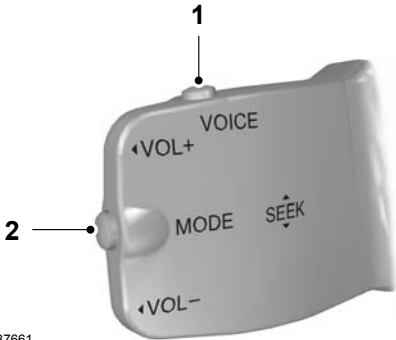

E87661

- 1 Voice button
- 2 Mode button

Incoming calls can be accepted by pressing the MODE button once. Press the button again to end the call.

USING THE TELEPHONE - VEHICLES WITHOUT: NAVIGATION SYSTEM

This chapter describes the phone functions of the audio unit.

Note: Refer to your audio guide for details of the controls.

An active phone must be present.

Even if connected to the audio unit, your phone can still be used in the usual way.

Note: You can exit the phone menu by pressing any source button **CD**, **AM/FM** or **AUX**.

Making a call

Dialling a number using voice control

Phone numbers can be dialled using voice control. See **Telephone commands** (page 192).

Dialling a number using the address book

You can access your phone address book via Bluetooth. The entries will appear in the unit display.

1. Press the **PHONE** or the call accept button.
2. Press the **MENU** button.
3. Keep pressing the **MENU** button until **PHONEBOOK** appears.
4. Press the seek buttons to select the desired phone number.

Note: Press and hold the seek button to skip to the next letter in the alphabet.

5. Press the **PHONE** or the call accept button to dial the selected phone number.

Dialling a number using the address book - Sony radio

You can access your phone address book via Bluetooth. The entries will appear in the unit display.

1. Press the **PHONE** button.
2. Press the seek button until the phone book is shown.
3. Press the up/down arrow buttons to select the desired phone number.

Note: Press and hold the up/down arrow buttons to skip to the next letter in the alphabet.

4. Press the **PHONE** or the call accept button to dial the selected phone number.

Telephone

Dialling a number using the telephone keypad

If you have an audio unit with a telephone keypad (buttons 0-9, * and #):

1. Press the call accept button. Press the **PHONE** button if you have a Sony radio.
2. Dial the number using the telephone keypad on the audio unit.
3. Press the call accept button.

Note: *If you enter an incorrect digit whilst entering a phone number, press the seek left button to erase the last digit. A long press will erase the complete string of digits.*

*Press and hold **0** to enter a + digit.*

Ending a call

Calls can be ended by pressing the call reject button.

Audio units without a telephone keypad can also end a call by pressing either **PHONE**, **CD**, **AM/FM** or **ON/OFF**, or by pressing the **MODE** button on the remote control

Redialling a number

1. Press the **PHONE** or the call accept button.
2. Press the **MENU** button.
3. Select the **CALL OUT** list or the **CALL IN** list. On some audio units, select the **MISSED**, **INCOMING** or **OUTGOING** calls list.

Note: *If the active phone does not provide a call out list, the last outgoing call number/entry can be redialled.*

4. Press the seek button on the audio unit.
5. Press the **PHONE** or the call accept button to dial the desired phone number.

Redialling a number - Sony radio

1. Press the **PHONE** or the call accept button.
2. Press the seek button until the desired list is displayed.

Note: *If the active phone does not provide a call out list, the last outgoing call number/entry can be redialled.*

3. Press the up/down buttons to select the desired phone number.
4. Press the **PHONE** or the call accept button to dial the phone number.

Redialling the last dialled number - Sony radio

1. Press the call accept button.
2. Press the call accept button a second time to dial the number.

Receiving an incoming call

Accepting an incoming call

Incoming calls can be accepted by pressing either the call accept button, the **PHONE** button or the **MODE** button on the remote control.

Rejecting an incoming call

Incoming calls can be rejected by pressing the call reject button.

Audio units without a telephone keypad can also reject a call by pressing either **PHONE**, **CD**, **AM/FM** or **ON/OFF**.

Receiving a second incoming call

Note: *The second incoming call function must be activated in your phone.*

If there is an incoming call whilst there is an ongoing call, a beep will be heard and you will have the option to end the active call and to accept the incoming call.

Telephone

Accepting a second incoming call

Second incoming calls can be accepted by pressing either the call accept button, the **PHONE** button, or the **MODE** button on the remote control.

Rejecting a second incoming call

Second incoming calls can be rejected by pressing the call reject button. Units without a telephone keypad can also reject a second incoming call by pressing the **CD** button, or the **AM/FM** button.

Muting the microphone

During a call, it is possible to mute the microphone. Whilst muted, confirmation will appear in the display.

Audio units with green call accept button

Press the call accept button. Press the button once again to turn this function off.

Audio units without green call accept button

Press the seek up or down button. Press the button once again to turn this function off.

Changing the active phone

Note: *Phones must be bonded to the system before they can be made active.*

Using the station storage button

Note: *This process is only for audio units without a telephone keypad.*

1. Press the **PHONE** button on the audio unit.
2. Press the preset number required (using the station preset buttons 1 - 6).

Using the audio unit menu

Note: *After bonding a phone to the system, this becomes the active phone.*

1. Press the **PHONE** or call accept button.
2. Press the **MENU** button on the audio unit.
3. Select the **ACTIVE PHONE** option on the audio unit.
4. Scroll through the different stored phones by using the seek buttons to display the bonded phones.
5. Press the **MENU** button to select the phone which is to be the active phone.

Debonding a bonded phone

A bonded phone can be deleted from the system at any time, unless a phone call is in progress.

1. Press the **PHONE** or call accept button.
2. Press the **MENU** button on the audio unit.
3. Select the **DEBOND** option on the audio unit.
4. Scroll through the different phones by using the seek buttons and display the phone to be debonded.
5. Press the **MENU** button to select the phone which is to be debonded.

Debonding a bonded phone - Sony radio

A bonded phone can be deleted from the system at any time, unless a phone call is in progress.

1. Press the **PHONE** button.
2. Press the up/down arrow buttons until you reach the **DEBOND** option.

Telephone

3. Scroll through the different phones by using the seek buttons and display the phone to be debonded.
4. Press the OK button to be debond.

USING THE TELEPHONE - VEHICLES WITH: NAVIGATION SYSTEM

This chapter describes the phone functions of the Navigation System.

Note: Refer to your *Navigation System guide* for details of the controls.

An active phone must be present.

Even if connected to the Navigation System, your phone can still be used in the usual way.

Making a call

Dialling a number

Phone numbers can be dialled using voice control. See **Voice control** (page 182).

Ending a call

Calls can be ended by pressing either the **END** button, the **MODE** button on the remote switch or the **ON/OFF** button on the navigation system.

Redialling a number

1. Press the **PHONE** button on the unit.
2. Select **REDIAL**.

Receiving an incoming call

Accepting an incoming call

Incoming calls can be accepted by pressing either the call accept button, the **MODE** button on the remote control, the **PHONE** button on the unit or by using the **ACCEPT** option in the menu.

Rejecting an incoming call

Incoming calls can be rejected by pressing either the call reject button, the **CD** or **AM/FM** buttons on the unit, or by using the **REJECT** option in the menu.

Receiving a second incoming call

Note: The second incoming call function must be activated in your phone.

If there is an incoming call, whilst there is an ongoing call, a beep will be heard and you will have the option to end the active call and to accept the incoming call.

Accepting a second incoming call

Second incoming calls can be accepted by pressing either the call accept button, the **MODE** button on the remote control, the **PHONE** button on the unit or by using the **ACCEPT** option in the menu.

Note: This will cancel the ongoing call.

Rejecting a second incoming call

Second incoming calls can be rejected by pressing either the call reject button, or one of the following buttons on the unit: **CD, AM/FM**.

Muting the microphone

During a call, it is possible to mute the microphone. Whilst muted, confirmation will appear in the display.

DVD navigation units

Press the mute button (symbol of a microphone with a line through it). Press the button once again to turn this function off.

Telephone

CD navigation units

Press the microphone mute button. Press the button once again to turn this function off.

Changing the active phone

Note: *Phones must be bonded to the system before they can be made active.*

Note: *After bonding a phone to the system, this becomes the active phone.*

1. Press the **PHONE** button on the unit.
2. Using the **BT SETTINGS** option in the menu, select the active phone from the list.

Debonding a bonded phone

A bonded phone can be deleted from the system at any time, unless a phone call is in progress.

1. Press the **PHONE** button on the unit.
2. Select the **BT SETTINGS** option in the menu.
3. Select the **DEBOND** option in the menu.
4. Select the phone from the list.

Voice control

PRINCIPLE OF OPERATION

CAUTION

 Using the system with the engine off will drain the battery.

Voice recognition enables operation of the system without the need to divert your attention from the road ahead in order to change settings, or receive feedback from the system.

Whenever you issue one of the defined commands with the system active, the voice recognition system converts your command into a control signal for the system. Your inputs take the form of dialogues or commands. You are guided through these dialogues by announcements or questions.

Please familiarise yourself with the functions of the system before using voice recognition.

Supported commands

The voice control system allows you to control the following vehicle functions:

- Bluetooth phone
- radio
- CD Player/CD Changer
- external device (USB)
- external device (iPod)
- automatic climate control
- navigation system (DVD units only - refer to separate DVD navigation handbook).

System response

As you work through a voice session the system will prompt you with a beep tone each time the system is ready to proceed.

Do not try to give any commands until the beep tone has been heard. The voice control system will repeat each spoken command back to you.

If you are not sure how to continue say "HELP" for assistance or "CANCEL" if you do not wish to continue.

The "HELP" function provides only a subset of the available voice commands. Detailed explanations of all possible voice commands can be found on the following pages.

Voice commands

All voice commands should be given using a natural speaking voice, as if speaking to a passenger or on the phone. Your voice level should be dependant on the surrounding noise level inside or outside the vehicle but do not shout.

USING VOICE CONTROL

System operation

The order and content of the voice controls are given in the following lists. The tables show the sequence of user voice commands and system responses for each available function.

<> indicates a number or stored name tag to be inserted by the user.

Short cuts

There are a number of voice command short cuts available, which allow you to control some vehicle features without having to follow the complete command menu. These are:

- phone: "MOBILE NAME", "DIAL NUMBER", "DIAL NAME", and "REDIAL"
- CD player/CD changer: "DISC" and "TRACK"

Voice control

- automatic climate control: "TEMPERATURE", "AUTO MODE", "DEFROSTING/DEMISTING ON" and "DEFROSTING/DEMISTING OFF"
- radio: "TUNE NAME"
- external device (USB): "TRACK"
- external device (iPod): "TRACK"
- SD card: "TRACK".

Start communicating with the system

Before you can start talking to the system you first have to press the **VOICE** or **MODE** button for each operation and wait until the system answers with a beep. See **Voice control** (page 40).

Press the button again to cancel the voice session.

Name tag

The name tag functionality can support the phone, audio and navigation features by using the "STORE NAME" function. You can assign name tags to items such as favourite radio stations and personal phone contacts. See **Audio unit commands** (page 183). See **Telephone commands** (page 192). See **Navigation system commands** (page 197).

- Store up to 20 name tags per function.
- The average recording time for each name tag is approximately 2-3 seconds.

AUDIO UNIT COMMANDS

CD Player

You can control playback directly by voice control.

Overview

The overview below shows the available voice commands. The following lists will give further information about the complete command menu in selected examples.

"CD PLAYER"
"HELP"
"PLAY"
"TRACK"*
"SHUFFLE ALL "
"SHUFFLE FOLDER"**
"SHUFFLE OFF"
"REPEAT FOLDER"**

Voice control

"CD PLAYER"
"REPEAT TRACK"
"REPEAT OFF"

* Can be used as a shortcut.

** Only available if the CD contains audio data files like MP3 or WMA.

Track

You can choose a track on your CD directly.

Steps	User says	System answer
1	"CD PLAYER"	"CD PLAYER"
2	"TRACK"*	"TRACK NUMBER PLEASE"
3	"<a number between 1 and 99>"**	"TRACK <number>"

* Can be used as a shortcut.

** Additionally, numbers can be spoken as up to four single digits (for example "2", "4", "5" for track 245)

Shuffle all

To set random playback.

Steps	User says	System answer
1	"CD PLAYER"	"CD PLAYER"
2	"SHUFFLE ALL"	

CD Changer

Overview

The overview below shows the available voice commands. The following lists will give further information about the complete command menu in selected examples.

Voice control

"CD CHANGER"
"HELP"
"PLAY"
"DISC"*
"TRACK"*
"SHUFFLE ALL"
"SHUFFLE CD"
"SHUFFLE FOLDER"**
"SHUFFLE OFF"
"REPEAT CD"
"REPEAT FOLDER"**
"REPEAT TRACK"
"REPEAT OFF"

* Can be used as a shortcut.

** Only available if the CD contains audio data files like MP3 or WMA.

Disc

If you have a CD changer you can choose the disc number.

Steps	User says	System answer
1	"CD CHANGER"	"CD CHANGER"
2	"DISC"*	"DISC NUMBER PLEASE"
3	"<a number between 1 and 6>"	"DISC <number>"

* Can be used as a shortcut.

Track

You can choose a track on your CD directly.

Voice control

Steps	User says	System answer
1	"CD CHANGER"	"CD CHANGER"
2	"TRACK"*	"TRACK NUMBER PLEASE"
3	"<a number between 1 and 99>"**	"TRACK <number>"

* Can be used as a shortcut.

** Additionally, numbers can be spoken as up to four single digits (for example "2", "4", "5" for track 245)

Shuffle CD

To set random playback within the CD contents.

Steps	User says	System answer
1	"CD CHANGER"	"CD CHANGER"
2	"SHUFFLE CD"	

Radio

The radio voice commands support the functionality of the radio and allow you to tune radio stations by voice control.

Overview

The overview below shows the available voice commands. The following lists will give further information about the complete command menu.

"RADIO"
"HELP"
"AM"
"FM"
"TUNE NAME"*
"DELETE NAME"
"DELETE DIRECTORY"
"PLAY DIRECTORY"
"STORE NAME"

Voice control

"RADIO"
"PLAY"

* Can be used as a shortcut.

Tune frequency

This function allows you to tune your radio by voice commands.

Steps	User says	System answer
1	"RADIO"	"RADIO"
2	"AM"	"AM FREQUENCY PLEASE"
	"FM"	"FM FREQUENCY PLEASE"
3	"<frequency>"*	"TUNE <frequency>"

* The frequency may be entered in a variety of ways. Refer below for representative examples.

FM band: 87.5 - 108.0 in increments of 0.1

- "Eighty nine point nine" (89.9)
- "Ninety" (90.0)
- "One hundred point five" (100.5)
- "One zero one point one" (101.1)
- "One zero eight" (108.0)

AM/MW band: 531 - 1602 in increments of 9

AM/LW band: 153 - 281 in increments of 1

- "Five thirty one" (531)
- "Nine hundred" (900)
- "Fourteen forty" (1440)
- "Fifteen zero three" (1503)
- "Ten eighty" (1080)

Store name

If you have tuned a radio station, you can store it with a name in the directory.

Steps	User says	System answer
1	"RADIO"	"RADIO"
2	"STORE NAME"	"STORE NAME" "NAME PLEASE"
3	"<name>"	"REPEAT NAME PLEASE"
4	"<name>"	"STORING NAME" "<name> STORED"

Voice control

Tune name

This function allows you to call up a stored radio station.

Steps	User says	System answer
1	"RADIO"	"RADIO"
2	"TUNE NAME"*	"NAME PLEASE"
3	"<name>"	"TUNE <name>"

* Can be used as a shortcut.

Delete name

This function allows you to delete a stored radio station.

Steps	User says	System answer
1	"RADIO"	"RADIO"
2	"DELETE NAME"	"NAME PLEASE"
3	"<name>"	"DELETE <name>" "CONFIRM YES OR NO"
4	"YES"	"DELETED"
	"NO"	"COMMAND CANCELLED"

Play directory

This function allows you to let the system tell you all of the stored radio stations.

Steps	User says	System answer
1	"RADIO"	"RADIO"
2	"PLAY DIRECTORY"	"PLAY <DIRECTORY>"

Delete directory

This function allows you to delete all stored radio stations at once.

Voice control

Steps	User says	System answer
1	"RADIO"	"RADIO"
2	"DELETE DIRECTORY"	"DELETE DIRECTORY" "CONFIRM YES OR NO"
3	"YES"	"RADIO DIRECTORY DELETED"
	"NO"	"COMMAND CANCELLED"

Play

This function switches the audio source to the radio mode.

Steps	User says	System answer
1	"RADIO"	"RADIO"
2	"PLAY"	

Auxiliary input

This function allows you to switch the audio source to the attached auxiliary input device.

Steps	User says	System answer
1	"EXTERNAL DEVICE"	"EXTERNAL DEVICE"
2	"LINE IN"	"LINE IN"

External devices - USB

These voice commands support the functionality of an external USB device which may be connected to the audio unit.

Overview

The overview below shows the available voice commands. The following lists will give further information about the complete command menu in selected examples.

"EXTERNAL DEVICE", "USB"
"HELP"

Voice control

"EXTERNAL DEVICE", "USB"
"PLAY"
"TRACK"*
"PLAYLIST"**
"FOLDER"**
"SHUFFLE ALL "
"SHUFFLE FOLDER"
"SHUFFLE PLAYLIST"
"SHUFFLE OFF"
"REPEAT TRACK"
"REPEAT FOLDER"
"REPEAT OFF"

* Can be used as a shortcut.

** Playlists and folders activated by voice control must be assigned special filenames. See **General information** (page 200).

USB play

This function allows you to switch the audio source to the attached USB device.

Steps	User says	System answer
1	"EXTERNAL DEVICE"	"EXTERNAL DEVICE"
2	"USB"	"USB"
3	"PLAY"	

USB Track

You can choose a track on your USB device directly.

Voice control

Steps	User says	System answer
1	"EXTERNAL DEVICE"	"EXTERNAL DEVICE"
2	"USB"	"USB"
3	"TRACK"	"TRACK NUMBER PLEASE"
4	"<a number between 1 and 99>"*	"TRACK <number>"

* Additionally, numbers can be spoken as up to four single digits (for example "2", "4", "5" for track 245)

External devices - iPod

These voice commands support the functionality of an iPod which may be connected to the audio unit.

Overview

The overview below shows the available voice commands. The following lists will give further information about the complete command menu in selected examples.

"EXTERNAL DEVICE", "IPOD"
"HELP"
"PLAY"
"TRACK"*
"PLAYLIST"**
"SHUFFLE ALL"
"SHUFFLE PLAYLIST"
"SHUFFLE OFF"
"REPEAT TRACK"
"REPEAT OFF"

* Can be used as a shortcut.

** Playlists activated by voice control must be assigned special filenames. See **General information** (page 200).

Voice control

iPod Track

You can choose a track off the all titles list of your iPod directly.

Steps	User says	System answer
1	"EXTERNAL DEVICE"	"EXTERNAL DEVICE"
2	"IPOD"	"IPOD"
3	"TRACK"*	"TRACK NUMBER PLEASE"
4	"<a number between 1 and 99>"**	"TRACK <number>"

* Can be used as a shortcut.

** Additionally, numbers can be spoken as up to five single digits (for example "5", "2", "4", "5", "3" for track 52453), to a limit of 65535.

iPod playlist

You can choose a playlist from your iPod directly.

Steps	User says	System answer
1	"EXTERNAL DEVICE"	"EXTERNAL DEVICE"
2	"IPOD"	"IPOD"
3	"PLAYLIST"*	"PLAYLIST NUMBER PLEASE"
4	"<a number between 1 and 10>"	"PLAYLIST <number>"

* Playlists activated by voice control must be assigned special filenames. See **General information** (page 200).

TELEPHONE COMMANDS

Phone

Your phone system allows you to create an additional phonebook. The stored entries can be dialled by voice control. Phone numbers stored by using voice control are stored on the vehicle system and not in your phone.

Overview

The overview below shows the available voice commands. The following lists will give further information about the complete command menu in selected examples.

Voice control

"PHONE"
"HELP"
"MOBILE NAME"*
"DIAL NUMBER"*
"DIAL NAME"*
"DELETE NAME"
"DELETE DIRECTORY"
"PLAY DIRECTORY"
"STORE NAME"
"REDIAL"*
"ACCEPT CALLS"
"REJECT CALLS"

* Can be used as a shortcut.

Phone functions

Dial number

Phone numbers can be dialled after giving the name tag voice command.

Steps	User says	System answer
1	"PHONE"	"PHONE"
2	"DIAL NUMBER"*	"NUMBER PLEASE"
3	"<phone number>"	"<phone number> CONTINUE?"
4	"DIAL "	"DIALLING"
	"CORRECTION"	"<repeat last part of number> CONTINUE?"

* Can be used as a shortcut.

Voice control

Dial name

Phone numbers can be dialled after giving the name tag voice command.

Steps	User says	System answer
1	"PHONE"	"PHONE"
2	"DIAL NAME"*	"NAME PLEASE"
3	"<name>"	"DIAL <name>" "CONFIRM YES OR NO"
4	"YES"	"DIALLING"
	"NO"	"COMMAND CANCELLED"

* Can be used as a shortcut.

Redial

This function allows you to redial the last dialled phone number.

Steps	User says	System answer
1	"PHONE"	"PHONE"
2	"REDIAL"*	"REDIAL" "CONFIRM YES OR NO"
3	"YES"	"DIALLING"
	"NO"	"COMMAND CANCELLED"

* Can be used as a shortcut.

Mobile name

This function allows you to access phone numbers stored with a name tag in your mobile phone.

Steps	User says	System answer
1	"PHONE"	"PHONE"

Voice control

Steps	User says	System answer
2	"MOBILE NAME"*	"MOBILE NAME" "<phone dependent dialogue>"

* Can be used as a shortcut.

DTMF (Tone dialling)

This function transfers spoken numbers into DTMF tones. For example, to make a remote enquiry to your home answering machine or to enter a PIN number etc.

Note: DTMF can only be used during an ongoing call. Press the VOICE button and wait for the system prompt.

Can only be used with vehicles installed with a dedicated VOICE button.

Steps	User says	System answer
1		"NUMBER PLEASE"
2	"<numbers 1 to 9, zero, hash, star>"	

Create a phonebook

Store name

New entries can be stored with the "STORE NAME" command. This feature can be used to dial a number by calling up the name instead of the full phone number.

Steps	User says	System answer
1	"PHONE"	"PHONE"
2	"STORE NAME"	"STORE NAME" "NAME PLEASE"
3	"<name>"	"REPEAT NAME PLEASE"
4	"<name>"	"STORING NAME" "<name> STORED" "NUMBER PLEASE"
5	"<phone number>"	"<phone number>"
6	"STORE"	"STORING NUMBER" "<phone number>" "NUMBER STORED"

Voice control

Delete name

Stored names can also be deleted from the directory.

Steps	User says	System answer
1	"PHONE"	"PHONE"
2	"DELETE NAME"	"NAME PLEASE"
3	"<name>"	"DELETE <name>" "CONFIRM YES OR NO"
4	"YES"	"<name> DELETED"
	"NO"	"COMMAND CANCELLED"

Play directory

Use this function to let the system tell you all stored entries.

Steps	User says	System answer
1	"PHONE"	"PHONE"
2	"PLAY DIRECTORY"	"PLAY DIRECTORY"

Delete directory

This function allows you to delete all entries in one go.

Steps	User says	System answer
1	"PHONE"	"PHONE"
2	"DELETE DIRECTORY"	"DELETE DIRECTORY" "CONFIRM YES OR NO"
3	"YES"	"DIRECTORY DELETED"
	"NO"	"COMMAND CANCELLED"

Voice control

Main settings

Calls can be set to be automatically rejected using voice control.

Reject calls

Steps	User says	System answer
1	"PHONE"	"PHONE"
2	"REJECT CALLS"	"REJECT CALLS"
	"ACCEPT CALLS"*	"ACCEPT CALLS"

* use this command to turn the reject mode off

NAVIGATION SYSTEM COMMANDS

Please refer to your separate Navigation handbook for details of the command menus.

CLIMATE CONTROL COMMANDS

Climate

The climate voice commands supports the functionality of the fan speed, temperature and mode settings. Not all functions are available on all vehicles.

Overview

The overview below shows the available voice commands. The following lists will give further information about the complete command menu in selected examples.

"CLIMATE"
"HELP"
"FAN"*
"DEFROSTING/DEMISTING ON"*
"DEFROSTING/DEMISTING OFF"*
"TEMPERATURE"*

Voice control

"CLIMATE"
"AUTO MODE"*

* Can be used as a shortcut. On vehicles fitted with an English language module the "FAN" shortcut is not available.

Fan

This function allows you to adjust the fan speed.

Steps	User says	System answer
1	"CLIMATE"	"CLIMATE"
2	"FAN"*	"FAN SPEED PLEASE"
3	"MINIMUM"	"FAN MINIMUM"
	"<a number between 1 and 7>"	"FAN <number>"
	"MAXIMUM"	"FAN MAXIMUM"

* Can be used as a shortcut. On vehicles fitted with an English language module the "FAN" shortcut is not available.

Defrosting/Demisting

Steps	User says	System answer
1	"CLIMATE"	"CLIMATE"
2	"DEFROSTING ON/DEMISTING ON"*	"DEFROSTING ON/DEMISTING ON"
	"DEFROSTING OFF/DEMISTING OFF"*	"DEFROSTING OFF/DEMISTING OFF"

* Can be used as a shortcut.

Temperature

This function allows you to adjust the temperature.

Voice control

Steps	User says	System answer
1	"CLIMATE"	"CLIMATE"
2	"TEMPERATURE"*	"TEMPERATURE PLEASE"
3	"MINIMUM"	"TEMPERATURE MINIMUM"
	"<a number between 15 and 29 °C with 0.5 increments>" or "<a number between 59 and 84 °F>"	"TEMPERATURE <number>"
	"MAXIMUM"	"TEMPERATURE MAXIMUM"

* Can be used as a shortcut.

Auto mode





Steps	User says	System answer
1	"CLIMATE"	"CLIMATE"
2	"AUTO MODE"*	"AUTO MODE"

* Can be used as a shortcut. Can be deactivated by selecting a different temperature or fan speed.

Connectivity

GENERAL INFORMATION

CAUTIONS

-  Take care when handling external devices with exposed electrical connectors (such as the USB plug). Always replace the protective cap/shield when possible. There may be a risk of electrostatic discharge causing damage to the device.
-  Do not touch or handle the USB socket in the vehicle. Cover the socket when not in use.
-  Only use USB Mass-Storage device compliant devices.
-  Always switch your audio unit to a different source (for example the radio) before unplugging the USB device.
-  Do not install or connect USB hubs or splitters.

Note: *The system is only designed to recognize and read suitable audio files from a USB device that conforms to the USB Mass-Storage device class or an iPod. Not all available USB devices can be guaranteed to function with the system.*

Note: *It is possible to connect compatible devices with a trailing USB lead as well as those that plug into the vehicle USB socket directly (for example USB memory sticks and pen drives).*

Note: *Some USB devices with a higher power consumption may not be compatible (for example some larger hard drives).*

Note: *Access time to read the files on the external device will vary depending upon factors such as the file structure, size and device content.*

The system supports a range of external devices, to fully integrate with your audio unit via the USB and auxiliary input sockets. Once connected, control of the external device is possible via the audio unit.

A list of typical compatible devices are shown below:

- USB memory sticks
- USB portable hard drives
- MP3 players with USB connection
- iPod media players (refer to **www.ford-mobile-connectivity.com** for latest compatibility list).

The system is USB 2.0 full speed compatible, USB 1.1 host compliant and supports FAT 16/32 file systems.

Information on audio file structures for external devices

USB

Create only a single partition on the USB device.

If playlists are created, they must contain correct file paths referenced to the USB device. It is recommended to create the playlist after the audio files have been transferred to the USB device.

Playlists must be created in .m3u format.

Audio files must be in .mp3 format.

Do not exceed the following limits:

- 1000 items per folder (files, folders and playlists)
- 5000 folders per USB device (including playlists)
- 8 subfolder levels.

Connectivity

To enable voice control for custom playlists and folders, follow the procedure below:

- Create folders named with the structure "**Ford<*>**" where <*> is a number 1-10. For example "**Ford3**" without an extension.
- Create playlists named with the structure "**Ford<*>.m3u**" where <*> is a number 1-10. For example "**Ford5.m3u**" without any space between "**Ford**" and the number.

Thereafter, custom folders and playlists will be selectable with voice control. See **Audio unit commands** (page 183).

iPod

To enable voice control for custom playlists, create playlists named with the structure "**Ford<*>**" where <*> is a number 1-10. For example "**Ford7**" without any space between "**Ford**" and the number.

Thereafter, playlists will be selectable with voice control. See **Audio unit commands** (page 183).

CONNECTING AN EXTERNAL DEVICE

WARNING



Make sure the external device is securely mounted within the vehicle, and that trailing connections do not obstruct any of the driving controls.

External devices may be connected using the auxiliary input socket and the USB port. See **Auxiliary input (AUX IN) socket** (page 99). See **USB port** (page 100).

Connection

Plug in the device, and if necessary secure it to prevent movement within the vehicle.

Connecting an iPod

For optimum convenience and audio quality, we recommend that you purchase a dedicated single connection lead available from your dealer.

Alternatively, it is possible to connect your iPod using the standard iPod USB cable and a separate 3.5mm audio jack lead. If using this method preset the iPod volume to maximum and turn off any equalizer settings before making the connections:

- Connect the headphone output of the iPod to the AUX IN socket.
- Connect the USB cable from the iPod to the vehicle USB socket.

CONNECTING AN EXTERNAL DEVICE - VEHICLES WITH: BLUETOOTH

Connecting a Bluetooth audio device

CAUTION



As various standards exist, manufacturers are able to implement a variety of profiles in their Bluetooth devices. Because of this, an incompatibility can occur between the Bluetooth device and the system, which in some cases may limit system functionality. To avoid this situation, only recommended devices should be used.

Please visit the website **www.ford-mobile-connectivity.com** for full details.

Connectivity

Bonding the device

Note: *Some audio and navigation units have a separate Bluetooth audio menu. Use this to access setup and control.*

To connect the device to the system follow the same procedure as for Bluetooth hands free phones. See

Bluetooth setup (page 176).

Operating the device

Select Bluetooth audio as the active source.

Tracks can be accessed by skipping forwards and backwards using the steering wheel controls, or directly from the audio unit controls.

USING A USB DEVICE

Various icons are used to identify types of audio file, folders etc.



USB device is the active source



Folder



Playlist



Album



Artist



Filename



Track title



Information not available

Sony radio

Operation

Select the USB device as the audio source by repeatedly pressing the **CD/AUX** button until USB appears in the display. After first connecting the USB device, the first track within the first folder will start to play automatically. Subsequently, following audio source switching, the position of playback on the USB device is remembered.

To browse the device contents, press the up/down arrow key or the OK button once.

The display will show the track information, together with other important information described below:

- A vertical scroll bar on the right side of the display shows the current position of the folder view.
- ">" after an entry indicates a further level down is readable (for example a folder named after an album, with individual album tracks within that folder).
- "<" before the list indicates that a further level up is readable.
- Icons to the left of track/folder text indicate the type of file/folder. Refer to the list for an explanation of these icons.

To navigate the USB device contents, use the up/down arrow keys to scroll through lists, and the left/right keys to move up or down within the folder hierarchy. Once your desired track, playlist or folder is highlighted, press the OK button to select playback.

Connectivity

Note: *If you wish to jump to the top level of the USB device contents, press and hold the left arrow key.*

Audio control

Press the left and right arrow keys to skip backwards and forwards through tracks.

Press and hold the left/right arrow keys to enable fast rewind/fast forward through track content.

Press the up/down arrow key or the OK button to browse the device contents.

Press the MENU key to enter the USB menu. It is possible to enable shuffle and repeat functions here with respect to folders and playlists.

Press the SCAN button to scan the whole device, current folder or a playlist if it is in operation.

Press the **INFO** button to display the following:

- filename
- title
- artist
- album
- track number and playing time.

Repeated button presses will scroll through these displays.

CD Navigation units

Operation

Select the USB device as the audio source by pressing the **CD/AUX** button until DEVICES appears in the display. Select DEVICES and then select USB from the available device list. After first connecting the USB device, the first track within the first folder will start to play automatically. Subsequently, following audio source switching, the position of playback on the USB device is remembered.

To browse the device contents, press the **SELECT** button once.

The display will show the track information, together with other important information described below:

- A vertical scroll bar on the right side of the display shows the current position of the folder view.
- ">" after an entry indicates a further level down is readable (for example a folder named after an album, with individual album tracks within that folder).
- "<" to the left hand side of the display indicates that a further level up is readable.
- Icons to the left of track/folder text indicate the type of file/folder. Refer to the list for an explanation of these icons.

To navigate the USB device contents, use the rotary scroll/select button to browse through lists. Push the button to expand the contents within the highlighted playlist or folder, or to commence playback of a particular track. Press **ESC** to go up one level.

Audio control

Press the **SEEK** up and down keys to skip backwards and forwards through tracks.

Press and hold the **SEEK** keys to enable fast rewind/fast forward through track content.

Rotate or press the **SELECT** button to browse the device contents.

Press SHUFFLE or REPEAT buttons to enable shuffle and repeat functions with respect to folders and playlists. Different options may appear depending upon whether or not a playlist is in operation.

Connectivity

Press the **SCAN** button to scan the current playlist if it is in operation, or the complete USB device or folder.

Press the **INFO** button to display the following:

- filename
- title
- artist
- album
- track number and playing time.

DVD Navigation units

Operation

Select the USB device as the audio source by pressing the **CD/AUX** button until the USB button appears to the left of the display. Select USB from the available device list.

Note: *Some devices may be shown but not selectable, depending if the device is connected or not.*

After first connecting the USB device, the first track within the first folder will start to play automatically. Subsequently, following audio source switching, the position of playback on the USB device is remembered.

To browse the device contents, press the scroll up or down arrow button.

The display will show the track information, together with other important information described below:

- A vertical scroll bar on the right side of the display shows the current position of the folder view.
- ">" after an entry indicates a further level down is readable (for example a folder named after an album, with individual album tracks within that folder).

- "<" to the left hand side of the display indicates that a further level up is readable.
- Icons to the left of track/folder text indicate the type of file/folder. Refer to the list for an explanation of these icons.

To navigate the USB device contents, use the scroll buttons to browse through lists. Push the button to expand the contents within the highlighted playlist or folder, or to commence playback of a particular track. Press the left arrow key to go up one level.

Audio control

Press the **SEEK** up and down keys to skip backwards and forwards through tracks.

Press and hold the **SEEK** keys to enable fast rewind/fast forward through track content.

Press the scroll bar arrow keys to browse the device contents.

Press **SHUFFLE** or **REPEAT** buttons to enable shuffle and repeat functions with respect to folders and playlists.

Press the **SCAN** button to scan the current playlist if it is in operation, or the complete USB device or folder.

Press the **INFO** button to display the following:

- filename
- title
- artist
- album
- track number and playing time.

USING AN IPOD

Various icons are used to identify types of audio file, folders etc.

Connectivity



iPod is the active source



iPod playlist



iPod artist



iPod album



iPod genre



iPod song



iPod generic category



iPod generic media file

Sony radio

Operation

Select the iPod as the audio source by repeatedly pressing the **CD/AUX** button until iPod appears in the display.

The iPod menu list for browsing contents will be available through the radio display. Navigation of the contents follows the same principles as for iPod standalone use (for example search by artist, title, etc.). To browse the iPod contents, press the up/down arrow key or the OK button once.

The display will show the track information, together with other important information described below:

- A vertical scroll bar on the right side of the display shows the current position of the list view.
- ">" after an entry indicates a further level down is readable (for example all albums by a particular artist).
- "<" before the list indicates that a further level up is readable.
- An icon on the left side indicates the type of the currently displayed list (for example list of albums). Refer to the list for an explanation of these icons.

To navigate the iPod contents, use the up/down arrow keys to scroll through lists, and the left/right keys to move up or down within the hierarchy. Once your desired track, playlist, album, artist or genre is highlighted, press the OK button to select playback.

Note: *If you wish to jump to the top level of the iPod contents, press and hold the left arrow key.*

Audio control

Press the left and right arrow keys to skip backwards and forwards through tracks.

Press and hold the left/right arrow keys to enable fast rewind/fast forward through track content.

Press the up/down arrow key or the OK button to browse the iPod contents.

Press the **MENU** key to enter the iPod menu. It is possible to enable shuffle and repeat functions here. It is also possible to enable the iPod "Shuffle songs" option directly from the top level.

Press the **SCAN** button to scan the currently selected tracks.

Connectivity

Press the **INFO** button to display the following:

- title
- artist
- track number and playing time.

Repeated button presses will scroll through these displays.

CD Navigation units

Operation

Select the iPod as the audio source by pressing the **CD/AUX** button until **DEVICES** appears in the display. Select **DEVICES** and then select iPod from the available device list.

The iPod menu list for browsing contents will be available through the display. Navigation of the contents follows the same principles as for iPod standalone use (for example search by artist, title, etc.). To browse the iPod contents, press the **SELECT** button once.

The display will show the track information, together with other important information described below:

- A vertical scroll bar on the right side of the display shows the current position of the list view.
- ">" after an entry indicates a further level down is readable (for example all albums by a particular artist).
- "<" before the list indicates that a further level up is readable.
- An icon on the left side indicates the type of the currently displayed list (for example list of albums). Refer to the list for an explanation of these icons.

To navigate the iPod contents, use the rotary scroll/select button to browse through lists. Push the button to expand the contents within the highlighted playlist, album, artist, genre or to commence playback of a particular track. Press **ESC** to go up one level.

Audio control

Press the **SEEK** up and down keys to skip backwards and forwards through tracks.

Press and hold the **SEEK** keys to enable fast rewind/fast forward through track content.

Rotate or press the **SELECT** button to browse the iPod contents.

Press the **MENU** key to enter the iPod menu. It is possible to enable shuffle and repeat functions here. It is also possible to enable the iPod "Shuffle songs" option directly from the top level.

Press the **SCAN** button to scan the currently selected tracks.

Press the **INFO** button to display the following:

- title
- artist
- track number and playing time.

DVD Navigation units

Operation

Select the iPod as the audio source by pressing the **CD/AUX** button until the iPod button appears to the left of the display. Select iPod from the available device list.

Note: *Some devices may be shown but not selectable, depending if the device is connected or not.*

Connectivity

The iPod menu list for browsing contents will be available through the display. Navigation of the contents follows the same principles as for iPod standalone use (for example search by artist, title, etc.). To browse the iPod contents, press the scroll up or down arrow button.

The display will show the track information, together with other important information described below:

- A vertical scroll bar on the right side of the display shows the current position of the list view.
- ">" after an entry indicates a further level down is readable (for example all albums by a particular artist).
- "<" before the list indicates that a further level up is readable.
- An icon on the left side indicates the type of the currently displayed list (for example list of albums). Refer to the list for an explanation of these icons.

To navigate the iPod contents, use the scroll buttons to browse through lists. Push the button to expand the contents within the highlighted playlist, album, artist, genre or to commence playback of a particular track. Press the left arrow key to go up one level.

Audio control

Press the **SEEK** up and down keys to skip backwards and forwards through tracks.

Press and hold the **SEEK** keys to enable fast rewind/fast forward through track content.

Press the scroll bar arrow keys to browse the iPod contents.

Press the MENU key to enter the iPod menu. It is possible to enable shuffle and repeat functions here. It is also possible to enable the iPod "Shuffle songs" option directly from the top level.

Press the SCAN button to scan the currently selected tracks.

Press the **INFO** button to display the following:

- title
- artist
- track number and playing time.

ROAD SAFETY

WARNINGS



The system provides you with information designed to help you reach your destination quickly and safely.



For reasons of safety, the driver should only program the system when the vehicle is stationary.



The system provides no assistance with respect to stop signs, traffic lights, areas under construction or other important safety information.



Do not use the system until you have familiarised yourself with its operation.



Only view the system display when driving conditions permit.

Safety information

Read and follow all stated safety precautions. Failure to do so may increase your risk of collision and personal injury. Ford Motor Company shall not be liable for any damages of any type arising from failure to follow these guidelines.

If detailed viewing of route instructions is necessary, pull off the road when it is safe to do so and park your vehicle.

Do not use the navigation system to locate emergency services.

To use the system as effectively and safely as possible, always use the latest navigation information. Your dealer will be able to assist with this.

Navigation system

GETTING STARTED

CAUTION

 Using the system with the engine off will drain the battery.

Note: You will be charged when sending and receiving text messages.

Note: Refer to your phone handbook for all phone functions and operation.

Note: Keep the activation code (printed on the installation guide) in a safe place.

Note: Retain the activation text message in your mobile phone inbox.

Compatibility of phones

CAUTION

 As no common agreement exists, mobile phone manufacturers are able to implement a variety of profiles in their Bluetooth devices. Because of this, an incompatibility can occur between the phone and hands-free system, which in some cases may significantly degrade the system performance. To avoid this situation, only recommended phones should be used.

Please visit the website www.ford-mobile-connectivity.com for full details.

Installing the micro SD card

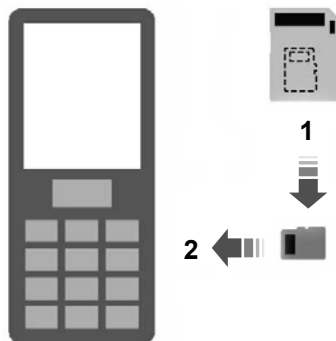

E114212

1. Remove the micro SD card from the adaptor.
2. Insert the micro SD card into the mobile phone.

Activating the mobile phone navigation system

Note: The radio must be switched on before connecting the mobile phone to the in-car GPS receiver.

Note: The Ford Mobile Navigation must be installed and activated on your mobile phone.

Note: It is possible to activate up to a **maximum** of three phones.

Note: Detailed instructions are available on the micro SD card and at www.ford-mobile-connectivity.com.

1. Switch the radio on.

Navigation system



E114213

2. Switch your mobile phone on and start the "Ford Mobile Navigation".
3. Choose "Select Destination".
4. Choose "Enter Address".
5. Change route options if necessary and start the route guidance.
6. The vehicle display will show the turn information. Voice instructions are heard via the vehicle speakers.

Note: *Your mobile phone will display your current position.*

7. You are able to exit the application and continue your route guidance after restarting the application.

Appendices

TYPE APPROVALS

FCC/INDUSTRY CANADA NOTICE

This device complies with Part 15 of the FCC Rules. Operation is subject to the following two conditions: (1) this device may not cause harmful interference, and (2) this device must accept any interference received, including interference that may cause undesired operation.

FCC ID: WJLRX-42

IC: 7847A-RX42

Changes or modifications to your device not expressly approved by the party responsible for compliance can void the user's authority to operate the equipment.

RX-42 - declaration of conformity

We, the party responsible for compliance, declare under our sole responsibility that the Handset Integration product RX-42 is in conformity with the provisions of the following Council Directive: 1999/5/EC. A copy of the Declaration of Conformity can be found at:

www.novero.com/declaration_of_conformity

The Bluetooth word mark and logos are owned by the Bluetooth SIG, Inc. and any use of such marks by Ford Motor Company is under license. Other trademarks and trade names are those of their respective owners.

TYPE APPROVALS

iPod is a trademark of Apple Inc.

TYPE APPROVALS



© 2008 NAVTEQ B.V. All rights reserved.

Appendices

(AT)	"© Bundesamt für Eich- und Vermessungswesen"
(PL)	"© EuroGeographics"
(FR)	"source: Géoroute® IGN France & BD Carto® IGN France"
(DE)	"Die Grundlagendaten wurden mit Genehmigung der zuständigen Behörden entnommen"
(GB)	"Based upon Crown Copyright material."
(GR)	"Copyright Geomatics Ltd."
(IT)	"La Banca Dati Italiana è stata prodotta usando quale riferimento anche cartografia numerica ed al tratto prodotta e fornita dalla Regione Toscana."
(NO)	"Copyright © 2000; Norwegian Mapping Authority"
(PT)	"Source: IgeoE – Portugal"
(ES)	"Información geográfica propiedad del CNIG"
(SE)	"Based upon electronic data © National Land Survey Sweden."
(CH)	"Topografische Grundlage: © Bundesamt für Landestopographie"

ELECTROMAGNETIC COMPATIBILITY

WARNINGS



Your vehicle has been tested and certified to European legislations relating to electromagnetic compatibility (2004/104/EC). It is your responsibility to ensure that any equipment you have fitted complies with applicable local legislations. Have any equipment fitted by properly trained technicians.

WARNINGS



Radio frequency (RF) transmitter equipment (e.g. cellular telephones, amateur radio transmitters etc.) may only be fitted to your vehicle if they comply with the parameters shown in the table below. There are no special provisions or conditions for installations or use.



Do not mount any transceiver, microphones, speakers, or any other item in the deployment path of the airbag system.



Do not fasten antenna cables to original vehicle wiring, fuel pipes and brake pipes.

Appendices

WARNINGS



Keep antenna and power cables at least 100mm from any electronic

WARNINGS

modules and airbags.

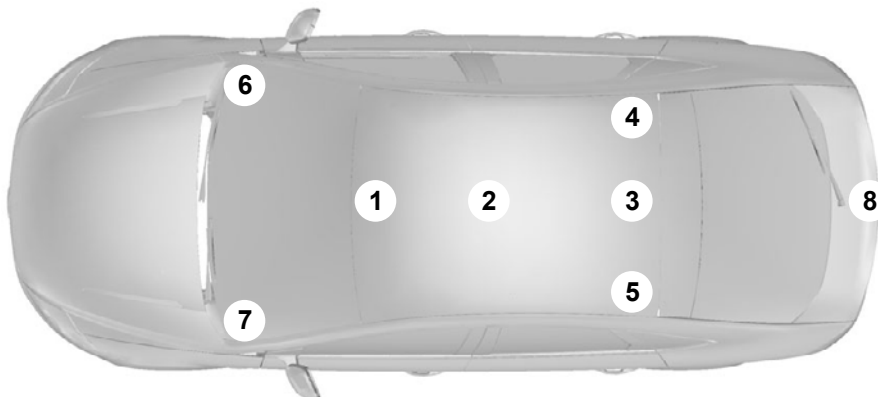

E85998

Frequency Band MHz	Maximum output power Watt (Peak RMS)	Antenna Positions
1 – 30	50 W	3, 8
30 – 54	50 W	2, 3
68 – 87.5	50 W	1, 2, 3, 4, 5
142 – 176	50 W	1, 2, 3, 4, 5
380 – 512	50 W	1, 2, 3, 4, 5
806 – 940	10 W (2 W ¹)	1, 2, 3, 4, 5 (6 ¹ , 7 ¹)
1200 – 1400	10 W	2
1710 – 1885	10 W (1 W ¹)	1, 2, 3, 4, 5 (6 ¹ , 7 ¹)
1885 – 2025	10 W (1 W ¹)	1, 2, 3, 4, 5 (6 ¹ , 7 ¹)
2400 – 2500	0.1 W	All positions

¹Only for GSM/3G cellular phones, with a patch antenna installed inside of the front windscreen.

Appendices

Note: *After the installation of RF transmitters, check for disturbances from and to all electrical equipment in the vehicle, both in the standby and transmit modes.*

Check all electrical equipment:

- with the ignition **ON**
- with the engine running
- during a road test at various speeds.

Check that electromagnetic fields generated inside the vehicle cabin by the transmitter installed do not exceed human exposure limits specified in EU directive 2004/40/EC.

Index

A

- A/C
See: Climate control.....80
- About this handbook.....5
- ABS
See: Brakes.....112
- ABS driving hints
See: Hints on driving with ABS.....112
- Accessories
See: Parts and accessories.....5
- Adaptive front lighting system
(AFS).....49
- Adjusting the steering wheel.....39
- Adjusting the windscreen washer
jets.....43
- AFS
See: Adaptive front lighting system
(AFS).....49
- Air conditioning
See: Climate control.....80
- Air vents.....80
- Alarm.....37
- All-wheel drive (AWD).....111
- Appendices.....211
- Arming the alarm.....37
Automatic arming delay.....37
Interior sensors.....37
- Arming the engine immobiliser.....36
- Audible warnings and indicators.....66
Automatic transmission.....66
Frost.....66
Key-in-ignition.....67
Key outside car.....66
Lights on.....67
Low fuel.....67
Seat belt reminder.....67
- Audio control.....39
Mode.....40
Seek.....40
Volume.....39
- Audio unit commands.....183
Auxiliary input.....189
CD Changer.....184
CD Player.....183
External devices - iPod.....191
External devices - USB.....189
Radio.....186
- Auto-dimming mirror.....62
- Autolamps.....47
- Automatic climate control.....83
Air distribution.....85
Blower.....84
Mono mode.....84
Recirculated air.....85
Setting the temperature.....84
Switching off the automatic climate
control.....85
Switching the air conditioning on and
off.....85
To switch mono mode back on.....84
To switch mono mode off.....84
- Windscreen defrosting and
demisting.....85
- Automatic transmission.....108
Emergency park position release
lever.....110
Hints on driving with an automatic
transmission.....110
Manual shifting - Vehicles with a 5 speed
transmission.....109
Selector lever positions.....108
Sport mode and manual shifting - Vehicles
with a 6 speed transmission.....109
- Autowipers.....41
- Auxiliary heater.....86
Diesel auxiliary heater (depending on
country).....89
Fuel operated heater (depending on
country).....89
Parking heater.....86
- Auxiliary input (AUX IN) socket.....99
- Auxiliary power sockets.....97
Power inverter.....97
- AWD
See: All-wheel drive (AWD).....111

B

- Bluetooth setup.....176
Handling of phones.....176
Requirements for Bluetooth
connection.....176
- Bonnet lock
See: Opening and closing the bonnet.....142

Index

- Booster cables
 - See: Using booster cables.....154
- Booster cushions.....19
 - Booster cushion (Group 3).....19
 - Booster seat (Group 2).....19
- Brake and clutch fluid check.....149
- Brakes.....112
 - Principle of operation.....112
- Bulb changing
 - See: Changing a bulb.....52
- Bulb specification chart.....58
- C**
- Car wash
 - See: Cleaning the exterior.....152
- Catalytic converter.....105
 - Driving with a catalytic converter.....105
- CD changer.....99
- Changing a bulb.....52
 - Approach lamp.....53
 - Central high mounted brake lamp.....56
 - Front fog lamps.....54
 - Headlamp.....52
 - Interior lamp.....56
 - Luggage compartment lamp.....58
 - Number plate lamp.....56
 - Reading lamps.....57
 - Rear fog lamps.....54
 - Rear lamps.....55
 - Side repeaters.....53
 - Vanity mirror lamp.....57
- Changing a fuse.....134
- Changing a road wheel.....156
 - Assembling the wheel brace.....158
 - Installing a road wheel.....160
 - Jacking and lifting points.....157
 - Locking wheel nuts.....156
 - Removing a road wheel.....159
 - Removing the wheel trim.....159
 - Vehicle jack.....156
 - Vehicles with a temporary spare wheel.....156
- Changing the remote control battery.....27
- Changing the wiper blades.....44
 - Rear window wiper blade.....45
 - Windscreen wiper blades.....44
- Checking the wiper blades.....43
- Child safety.....16
- Child safety locks.....21
 - Left-hand side.....21
 - Right-hand side.....21
- Child seat positioning.....17
 - All vehicles.....17
 - Vehicles with under floor storage.....17
- Child seats.....16
 - Child restraints for different mass groups.....16
- Cigar lighter.....97
- Cleaning the exterior.....152
 - Body paintwork preservation.....152
 - Cleaning the chrome trim.....152
 - Cleaning the headlamps.....152
 - Cleaning the rear window.....152
- Cleaning the interior.....152
 - Instrument cluster screens, LCD screens, radio screens.....153
 - Seat belts.....152
- Climate control.....80
 - Principle of operation.....80
- Climate control commands.....197
 - Climate.....197
- Coded keys.....36
- Cold weather precautions.....131
- Connecting an external device.....201
 - Connection.....201
- Connecting an external device - Vehicles With: Bluetooth.....201
 - Connecting a Bluetooth audio device.....201
- Connectivity.....200
 - General information.....200
- Convenience features.....96
- Coolant check
 - See: Engine coolant check.....148
- Cruise control.....120
 - Principle of operation.....120
- Cruise control
 - See: Using cruise control.....120
- Cup holders.....96
 - Seat back trays.....96

Index

D

- Detachable tow ball.....127
 - Driving with a trailer.....129
 - Inserting the tow ball arm.....128
 - Maintenance.....129
 - Removing the tow ball arm.....129
 - Unlocking the tow ball arm mechanism.....128
- Diesel particulate filter (DPF).....102
 - Regeneration.....103
- Direction indicators.....50
- Disabling the passenger airbag.....25
 - Disabling the passenger airbag.....26
 - Enabling the passenger airbag.....26
 - Fitting the passenger airbag deactivation switch.....25
- Disarming the alarm.....37
 - Britain and Ireland only.....38
- Disarming the engine immobiliser.....36
- DPF
 - See: Diesel particulate filter (DPF).....102
- Driving hints.....131
- Driving through water.....131
 - Driving through water131

E

- Electric exterior mirrors.....62
 - Electric folding mirrors.....62
 - Mirror tilting positions.....62
- Electric seats.....93
 - 6-way electric seat.....93
- Electric windows.....60
 - Anti-trap function.....60
 - Driver's door switches.....60
 - Global opening and closing.....60
 - Opening and closing the windows automatically.....60
 - Resetting the memory of the electric windows.....61
 - Safety switch for rear windows.....60
- Electromagnetic compatibility.....212
- Emergency equipment.....132
- Engine compartment overview - 2.0L Duratorq-TDCi (DW) Diesel.....145
- Engine compartment overview - 2.5L Duratec (V15).....144

- Engine coolant check.....148
 - Checking the coolant level.....148
 - Topping up.....148
- Engine immobiliser.....36
 - Principle of operation.....36
- Engine oil check.....147
 - Checking the oil level.....147
 - Topping up.....148
- Engine oil dipstick - 2.0L Duratorq-TDCi (DW) Diesel.....147
- Engine oil dipstick - 2.5L Duratec (V15).....147
- Exterior mirrors.....61
 - Manual folding mirrors.....61

F

- Fastening the seat belts.....24
- First aid kit.....132
- Floor mats.....100
- Fog lamp
 - See: Front fog lamps.....47
- Front fog lamps.....47
- Fuel and refuelling.....104
 - Technical specifications.....106
- Fuel burning heater
 - See: Auxiliary heater.....86
- Fuel consumption.....106
- Fuel consumption
 - See: Technical specifications.....106
- Fuel cut-off switch.....133
 - Vehicles with a Duratec engine.....133
- Fuel filler flap.....104
- Fuel quality - Diesel.....104
 - Long-term storage.....104
- Fuel quality - Petrol.....104
- Fuse box locations.....134
 - Engine compartment fuse box.....134
 - Passenger compartment fuse box.....134
- Fuses.....134
- Fuse specification chart.....135
 - Engine compartment fuse box.....135
 - Passenger compartment fuse box.....137

Index

- G**
- Gauges.....63
 - Engine coolant temperature gauge.....63
 - Fuel gauge.....64
 - Gearbox
 - See: Transmission.....108
 - General information on radio frequencies.....27
 - Getting started.....209
 - Activating the mobile phone navigation system.....209
 - Compatibility of phones.....209
 - Installing the micro SD card.....209
 - Glasses holder.....99
 - Global opening and closing.....34
 - Global closing.....34
 - Global opening.....34
- H**
- Handbrake
 - See: Parking brake.....112
 - Hazard warning flashers.....48
 - Headlamp levelling.....47
 - Recommended headlamp levelling control positions.....48
 - Headlamp washers.....43
 - Head restraints.....90
 - Adjusting the head restraint.....90
 - Removing the head restraint.....90
 - Heated seats.....94
 - Heated windows and mirrors.....86
 - Heated exterior mirrors.....86
 - Heated windows.....86
 - Heating
 - See: Climate control.....80
 - Hints on driving with ABS.....112
- I**
- Immobiliser
 - See: Engine immobiliser.....36
 - Information displays.....68
 - General information.....68
 - Information messages.....73
 - All wheel drive.....74
 - Doors open.....75
 - Keyless system.....75
 - Lighting.....76
 - Maintenance.....76
 - Message indicator.....74
 - Message symbols.....74
 - Power steering.....77
 - Stability control (ESP).....77
 - Transmission.....78
 - Tyre pressure monitoring system.....79
 - Viewing current messages.....74
 - Instrument lighting dimmer.....96
 - Instruments.....63
 - Interior lamps.....50
 - Courtesy lamp.....50
 - Reading lamps.....50
 - Vanity mirror lamps.....51
 - Introduction.....5
 - ISOFIX anchor points.....20
 - Attaching a child restraint with a top tether.....20
- J**
- Jump starting
 - See: Using booster cables.....154
- K**
- Keyless entry.....31
 - Disabled keys.....33
 - General information.....31
 - Locking and unlocking the doors with the key blade.....34
 - Locking the vehicle.....32
 - Passive key.....32
 - Unlocking the vehicle.....33
 - Keyless starting.....101
 - Failure to start.....102
 - Ignition on.....101
 - Starting a diesel engine.....101
 - Starting with automatic transmission.....101
 - Starting with manual transmission.....101
 - Stopping the engine.....102
 - Keys and remote controls.....27

Index

L

Lighting control.....	46
Headlamp flasher.....	46
Home safe lighting.....	46
Lighting control positions.....	46
Main and dipped beam.....	46
Parking lamps.....	46
Lighting.....	46
Load carriers	
See: Roof racks and load carriers.....	124
Load carrying.....	122
General information.....	122
Locking and unlocking.....	29
Automatic relocking.....	31
Central locking.....	29
Double locking.....	29
Double locking the doors with the key.....	29
Locking and unlocking confirmation.....	29
Locking and unlocking the doors and the luggage compartment lid with the remote control.....	29
Locking and unlocking the doors from inside.....	30
Locking and unlocking the doors with the key.....	29
Luggage compartment lid.....	30
Reprogramming the unlocking function.....	31
Locks.....	29
Luggage anchor points.....	122
Luggage covers.....	122
Stowing the luggage cover - vehicles with tyre repair kit.....	123

M

Maintenance.....	142
General information.....	142
Technical specifications.....	150
Manual climate control.....	81
Air conditioning.....	82
Air distribution control.....	81
Blower.....	81
Heating the interior quickly.....	81
Recirculated air.....	81
Ventilation.....	82

Manual seats.....	91
All vehicles.....	91
Manual transmission.....	108
Message centre	
See: Information displays.....	68
Mirrors	
See: Heated windows and mirrors.....	86
See: Windows and mirrors.....	60

N

Navigation introduction.....	208
Navigation system commands.....	197
Navigation system.....	209

O

Occupant protection.....	22
Principle of operation.....	22
Oil check	
See: Engine oil check.....	147
See: Opening and closing the bonnet.....	142

O

Opening and closing the bonnet.....	142
Closing the bonnet.....	143
Opening the bonnet.....	142

P

Parking aid.....	115
Principle of operation.....	115
Parking aid	
See: Using the parking aid.....	115
Parking brake.....	112
All vehicles.....	112
Parts and accessories.....	5
Look for the Ford logo on the following parts	6
Now you can be sure that your Ford parts are Ford parts.....	5

Index

- Personalised settings.....71
Chime deactivation.....73
Clock setting.....71
ESP.....71
Help screen and navigation
information.....72
Language setting.....72
Navigation information.....72
Steering.....71
Units of measure.....73
Power steering fluid check.....149
Topping up.....149
Programming the remote control.....27
- Q**
- Quick start.....8
Adjusting the steering wheel.....12
Airbag.....15
Autolamps.....14
Automatic climate control.....14
Autowipers.....14
Direction indicators.....14
Instrument panel overview.....8
Keyless entry.....12
Keyless starting.....12
Locking and unlocking.....11
Manual climate control.....13
Manual transmission.....15
Towing the vehicle on four wheels.....15
- R**
- Rear fog lamps.....47
Rear seats.....94
Creating a level load floor.....94
Folding the seatbacks down.....94
Folding the seatbacks up.....94
Rear under floor storage.....123
Rear view camera.....117
Principle of operation.....117
Rear window wiper and washers.....42
Intermittent wipe.....42
Rear window washer.....43
Reverse gear wipe.....42
Refuelling.....106
- Remote control battery
See: Changing the remote control
battery.....27
Remote control programming
See: Programming the remote control.....27
Removing a headlamp.....51
Repairing minor paint damage.....153
Road Safety.....208
Safety information.....208
Roof racks and load carriers.....124
Cycle carrier.....125
Installing the crossbars.....124
Roof rack.....124
Run flat tyres.....165
Principle of operation.....165
Replacing run flat tyres.....165
What to do if a run flat tyre has a
puncture.....165
Running-in.....131
Brakes and clutch.....131
Engine.....131
Tyres.....131
- S**
- Safety precautions.....104
Seat belt height adjustment.....24
Seat belt reminder.....24
Deactivating the seat belt reminder.....25
Seats.....90
Sitting in the correct position.....90
Snow chains
See: Using snow chains.....166
Speed control
See: Cruise control.....120
Stability control.....113
Principle of operation.....113
Stability control
See: Using stability control.....113
Starting the engine.....101
General information.....101
Status after a collision.....133
Steering wheel.....39
Storage compartments.....98
Front storage compartment.....98
Storage area under the rear seats.....98
Sun blinds.....96
Panoramic roof.....96

Index

- Switching off the engine.....103
Vehicles with a turbocharger.....103
- Symbols glossary.....5
Symbols in this handbook.....5
Symbols on your vehicle.....5
- ## T
- Technical specifications.....171
Technical specifications.....171
- Telephone commands.....192
Create a phonebook.....195
Main settings.....197
Phone.....192
Phone functions.....193
- Telephone controls.....177
Remote control.....177
- Telephone setup.....175
Bond another Bluetooth phone.....176
Making a phone an active phone.....175
Phonebook.....175
Phonebook categories.....175
- Telephone.....175
General information.....175
- Telephone
See: Using the telephone - Vehicles With:
Navigation System.....180
See: Using the telephone - Vehicles Without:
Navigation System.....177
- Toll reader.....99
- Towing a trailer.....127
Steep gradients.....127
- Towing points.....140
- Towing the vehicle on four
wheels.....140
All vehicles.....140
Vehicles with automatic
transmission.....141
- Towing.....127
- Transmission.....108
- Type approvals.....211
FCC/INDUSTRY CANADA NOTICE.....211
RX-42 - declaration of conformity.....211
- Tyre care.....166
- Tyre pressure monitoring system.....167
System reset.....167
- Tyre pressures
See: Technical specifications.....168
- Tyre repair kit.....161
Checking the tyre pressure.....164
General information.....161
Inflating the tyre.....162
Using the tyre repair kit.....161
- Tyres
See: Wheels and tyres.....156
- ## U
- USB port.....100
- Using an iPod.....204
CD Navigation units.....206
DVD Navigation units.....206
Sony radio.....205
- Using a USB device.....202
CD Navigation units.....203
DVD Navigation units.....204
Sony radio.....202
- Using booster cables.....154
To connect the booster cables.....154
To start the engine.....155
- Using cruise control.....120
Cancelling the set speed.....121
Changing the set speed.....120
Resuming the set speed.....121
Setting a speed.....120
Switching cruise control off.....121
Switching cruise control on.....120
- Using seat belts during pregnancy.....25
- Using snow chains.....166
Vehicles with stability control (ESP).....167
- Using stability control.....113
- Using the parking aid.....115
Manoeuvring with the parking aid.....115
Switching the parking aid on and off.....115
- Using the rear view camera.....117
Activating the rear view camera.....117
Deactivating the rear view camera.....119
Using the display.....117
Vehicles with parking aid.....119

Index

Using the telephone - Vehicles With:	
Navigation System.....	180
Changing the active phone.....	181
Debonding a bonded phone.....	181
Making a call.....	180
Muting the microphone.....	180
Receiving an incoming call.....	180
Receiving a second incoming call.....	180
Using the telephone - Vehicles Without:	
Navigation System.....	177
Changing the active phone.....	179
Debonding a bonded phone.....	179
Debonding a bonded phone - Sony radio.....	179
Making a call.....	177
Muting the microphone.....	179
Receiving an incoming call.....	178
Receiving a second incoming call.....	178
Using voice control.....	182
Name tag.....	183
System operation.....	182
Using winter tyres.....	166
V	
Vehicle battery.....	154
Vehicle care.....	152
Vehicle identification number (VIN).....	170
Vehicle identification plate.....	170
Vehicle identification.....	170
Vehicle recovery.....	140
Ventilation See: Climate control.....	80
Vents See: Air vents.....	80
VIN See: Vehicle identification number (VIN).....	170
Voice control.....	40
Principle of operation.....	182

W

Warning lamps and indicators.....	64
ABS warning lamp.....	64
Airbag warning lamp.....	64
Brake system lamp.....	64
Cruise control indicator.....	64
Direction indicators.....	64
Doors open warning lamp.....	64
Engine warning lamp.....	65
Front fog lamp indicator.....	65
Frost warning lamp.....	65
Glow plug indicator.....	65
Headlamp indicator.....	65
Ignition warning lamp.....	65
Low fuel level warning lamp.....	65
Main beam indicator.....	65
Message indicator.....	65
Oil pressure warning lamp.....	65
Power steering warning lamp.....	66
Rear fog lamp indicator.....	66
Seat belt reminder.....	66
Shift indicator.....	66
Stability control (ESP) indicator.....	66
Warning triangle.....	132
Washer fluid check.....	149
Washers See: Wipers and washers.....	41
Washing See: Cleaning the exterior.....	152
Wheels and tyres.....	156
General information.....	156
Technical specifications.....	168
Windows and mirrors.....	60
Windscreen washers.....	42
Windscreen wipers.....	41
Automatic wiper system.....	41
Intermittent wipe.....	41
Winter tyres See: Using winter tyres.....	166
Wipers and washers.....	41



Feel the difference

