

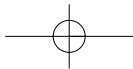

FordKa
Owner's handbook

Feel the difference





About this handbook

Thank you for choosing Ford. We recommend that you take some time to get to know your vehicle by reading this handbook.

The more that you know about it, the greater the safety and pleasure you will get from driving it.

NOTE This handbook describes product features and options available throughout the range, sometimes even before they are generally available. It may describe options not fitted to your vehicle.

NOTE Always use and operate your vehicle in line with all applicable laws and regulations.

NOTE Pass on this handbook when selling your vehicle. It is an integral part of the vehicle.

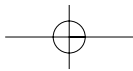
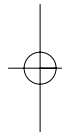
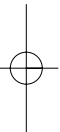

YOUR CAR

YOUR CAR

SAFETY

STARTING AND
DRIVINGWARNING
LIGHTS AND
MESSAGESIN AN
EMERGENCYMAINTENANCE
AND CARETECHNICAL
SPECIFICATIONSALPHABETICAL
INDEX

DASHBOARD (LEFT-HAND DRIVE)	3	EXTERNAL LIGHTS	37
DASHBOARD (RIGHT-HAND DRIVE)	4	WINDOW WASHING	38
SYMBOLS	5	EILING LIGHTS	40
THE FORD CODE SYSTEM	5	CONTROLS	41
THE KEYS	6	INTERIOR FITTINGS	43
INSTRUMENT PANEL AND ONBOARD INSTRUMENTS	10	FIXED GLASS ROOF	44
DIGITAL DISPLAY	13	DOORS	45
MULTIFUNCTIONAL DISPLAY	17	POWER WINDOWS	46
TRIP COMPUTER	24	BOOT	47
SEATS	26	BONNET	49
HEAD RESTRAINTS	27	ROOF RACK/SKI RACK	51
STEERING WHEEL	28	HEADLIGHTS	51
REARVIEW MIRRORS	29	ABS SYSTEM	53
CLIMATE COMFORT	30	ESP SYSTEM	54
HEATING AND VENTILATION	31	EOBD SYSTEM	57
MANUAL CLIMATE CONTROL SYSTEM	32	PARKING SENSORS	58
AUTOMATIC CLIMATE CONTROL SYSTEM	34	SOUND SYSTEM	60
		AT THE FILLING STATION	62
		ENVIRONMENTAL PROTECTION	63

DASHBOARD (LEFT-HAND DRIVE)

The presence and position of the controls, the instruments and the indicators may vary according to the versions.

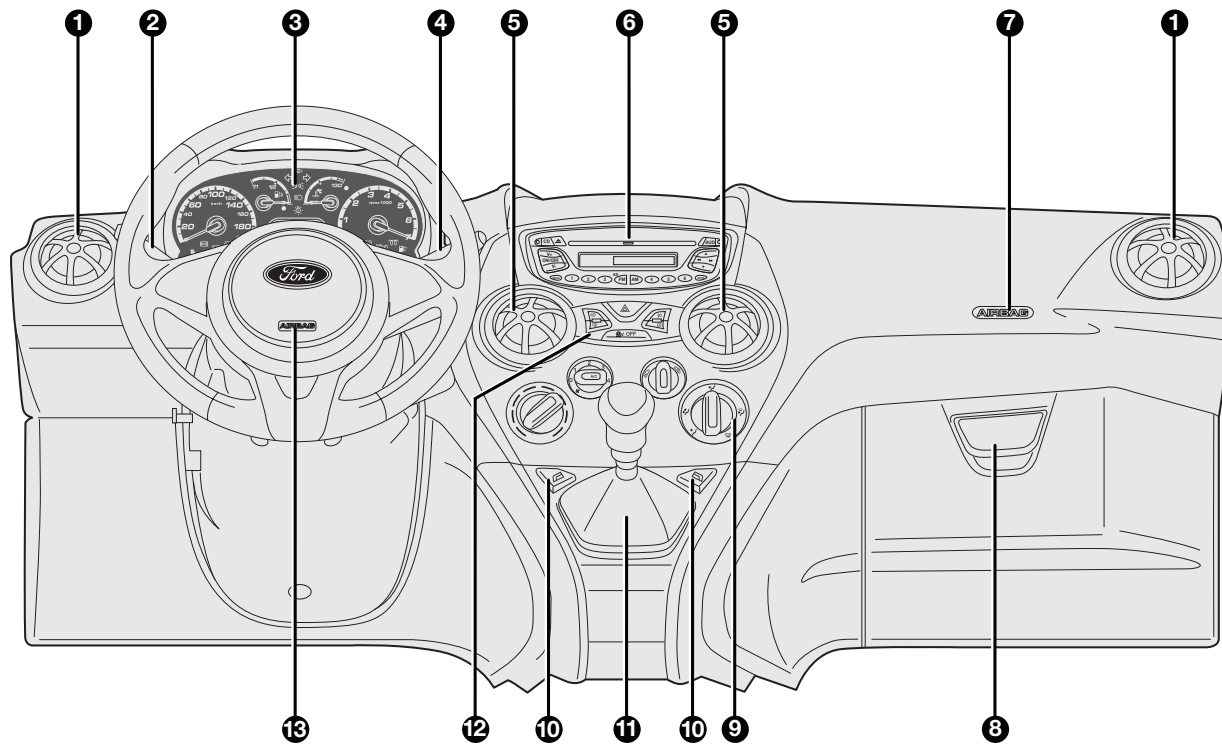

fig. 1

KA00001m

1. Side vent – 2. Left stalk: external lights control – 3. Instrument panel and warning lights – 4. Right stalk: controls wiper, washer, trip computer – 5. Central air vents – 6. Oddment/Car radio compartment – 7. Passenger side airbag – 8. Oddment compartment/hidden document tray – 9. Heating/ventilation/climate control – 10. Power windows control – 11. Oddment compartment – 12. Gear lever – 13. Driver side airbag.

YOUR CAR

SAFETY

STARTING AND
DRIVING

WARNING
LIGHTS AND
MESSAGES

IN AN
EMERGENCY

MAINTENANCE
AND CARE

TECHNICAL
SPECIFICATIONS

ALPHABETICAL
INDEX

3

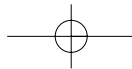

DASHBOARD (RIGHT-HAND DRIVE)

The presence and position of the controls, the instruments and the indicators may vary according to the versions.

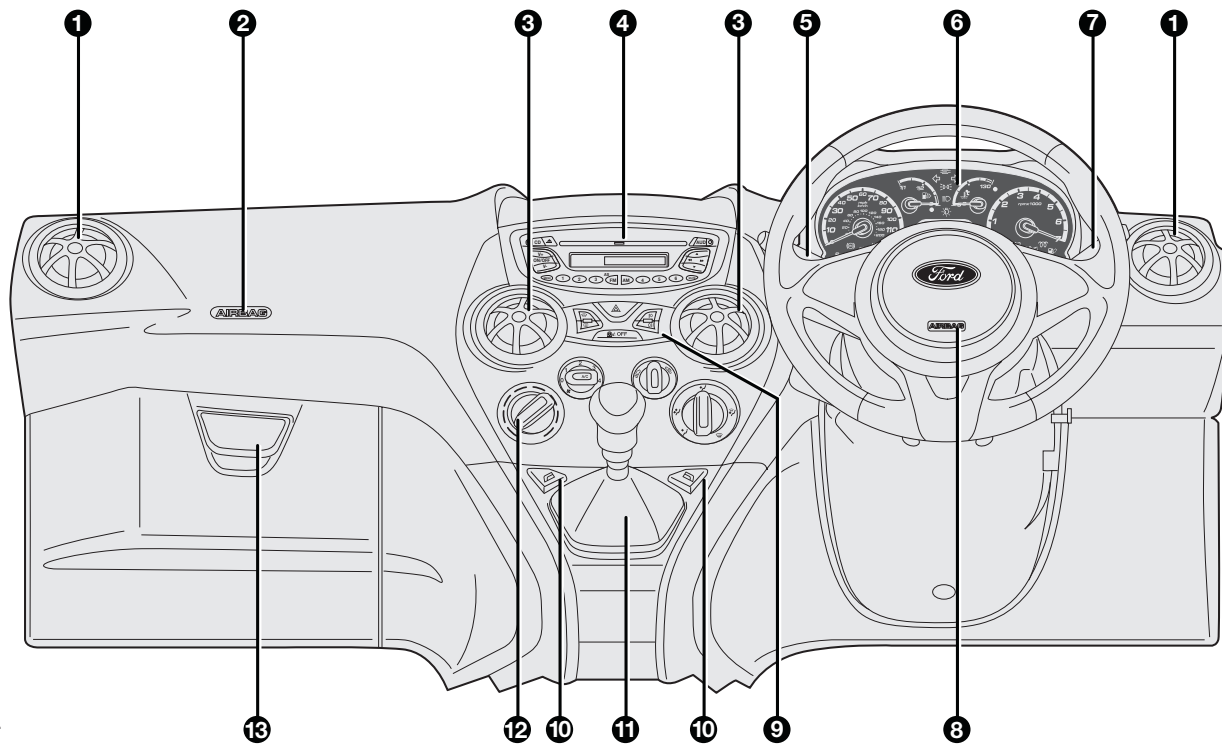
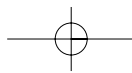

fig. 2

KA00112m

1. Side air vent – 2. Passenger side air bag – 3. Central air vents – 4. Oddment/radio compartment – 5. Left stalk: external lights control – 6. Instrument panel and warning lights – 7. Right stalk: controls windscreen wiper, rear wiper, trip computer – 8. Driver's Air bag – 9. Control panel – 10. Power window control – 11. Gear lever – 12. Heating/ventilation/climate control controls – 13. Oddment compartment.



SYMBOLS

Special coloured labels have been attached near or actually on some of the components of your car. These labels bear symbols that remind you of the precautions to be taken as regards that particular component.

THE FORD SYSTEM

This is an electrical engine locking system which increases protection from attempted theft of the car. It is automatically activated when the ignition key is extracted.

Each time the car is started by turning the ignition key to **MAR**, the Ford CODE system control unit sends an acknowledgement code to the engine control unit to deactivate the inhibitor.

If, during ignition, the code is not correctly recognized, the light  lights up on the instrument panel.

In this case, turn the key to **STOP** and then back to **MAR**. Try with the other keys provided if the problem persists. Contact a Ford Dealership if you still cannot start the engine.

IMPORTANT Each key has its own code which must be stored by the system ECU. Contact the Ford Dealership to have new keys (up to eight) stored with the code.

Warning light coming on when driving

- If the warning light  turns on, this means that the system is running a self-test (for example for a voltage drop).
- If the problem persists, contact the Ford Dealership.



The electronic components inside the key may be damaged if the key is subjected to violent shocks.

YOUR CAR

SAFETY

STARTING AND
DRIVINGWARNING
LIGHTS AND
MESSAGESIN AN
EMERGENCYMAINTENANCE
AND CARETECHNICAL
SPECIFICATIONSALPHABETICAL
INDEX

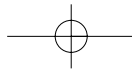

THE KEYS

CODE CARD (optional, for relevant versions/markets) fig. 3

The car is delivered with two copies of the ignition key and with the CODE card which bears the following:

A the electronic code.

B the mechanical key code to be given to the Ford Dealership when ordering duplicate keys.

IMPORTANT In order to ensure perfect efficiency of the electronic devices inside the keys, they should never be exposed to direct sunlight.



All the keys and the CODE card must be handed over to the new owner when selling the car.

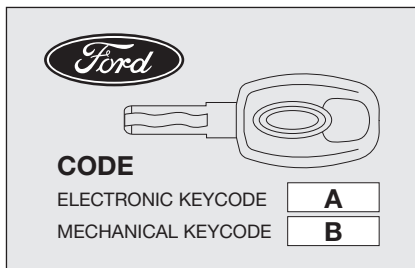

fig. 3

KA00121m

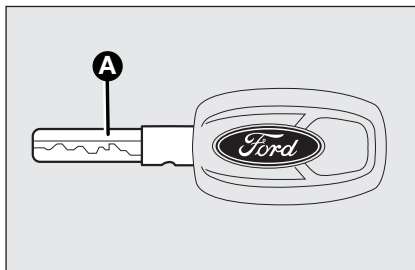

fig. 4

KA00002m

KEY WITHOUT REMOTE CONTROL fig. 4

The metal insert **A** enables:

- the ignition switch;
- the door and tailgate (where provided);
- the fuel cap lock/release;

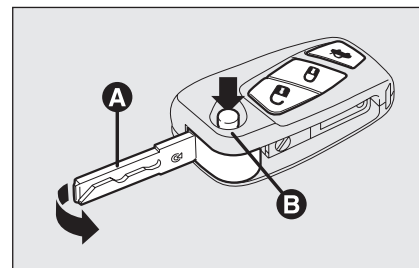

fig. 5

KA00003m

KEY WITH REMOTE CONTROL (where provided) fig. 5

The metal insert **A** enables:

- the ignition switch;
- the door locks;
- the fuel cap lock/release;

To open/close the metal insert, press button **B**.

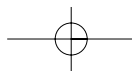

Door release

Short pressure on button : release of the doors, timed activation of the interior courtesy lights, lighting up of the turn signals and activation of courtesy lights (greeting lights) for relevant versions/market).

Door locks are automatically released in case of intervention of the fuel cut-off system.

When releasing the doors by means of the remote control, if a door is not opened within 45 seconds, the system automatically re-locks the doors.

Door locking

Short pressure on button : remote locking of doors with deactivation of the internal courtesy light and dual flashing of direction indicators (where present).

Locking does not take place if one or more doors are opened. This is indicated by a rapid flashing of the direction indicators (where applicable). The doors are not locked if the luggage compartment is open.

Remote tailgate opening

Press button  twice to release (open) the tailgate remotely.

Tailgate opening is indicated by lashing of direction indicators.

YOUR CAR

SAFETY

STARTING AND
DRIVINGWARNING
LIGHTS AND
MESSAGESIN AN
EMERGENCYMAINTENANCE
AND CARETECHNICAL
SPECIFICATIONSALPHABETICAL
INDEX

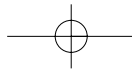

YOUR CAR

SAFETY

STARTING AND
DRIVINGWARNING
LIGHTS AND
MESSAGESIN AN
EMERGENCYMAINTENANCE
AND CARETECHNICAL
SPECIFICATIONSALPHABETICAL
INDEX



8

REQUEST FOR ADDITIONAL REMOTE CONTROLS

The system acknowledges up to 8 remote controls. Should a new remote control be necessary, contact a Ford Dealership and be ready to present the CODE card, a personal identity document and the car's ownership documents.

REPLACING THE BATTERY OF THE KEY WITH REMOTE CONTROL fig. 6

Battery replacement:

- press button **A** and open the metal insert **B**;
- rotate the screw **C** to  using a small point screwdriver;
- take out the battery case **D** and replace the battery **E** respecting its polarity;
- refit the battery case **D** inside the key and lock it turning the screw **C** to .

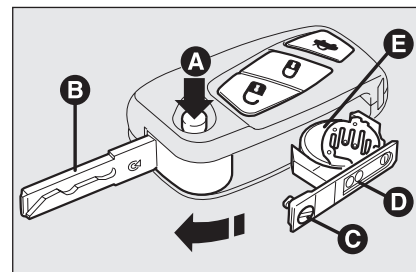
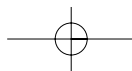

fig. 6

KA00004m



Used batteries are harmful to the environment. They should be disposed of as specified by law in special containers or taken to a Ford Dealership, which will take care of their disposal.



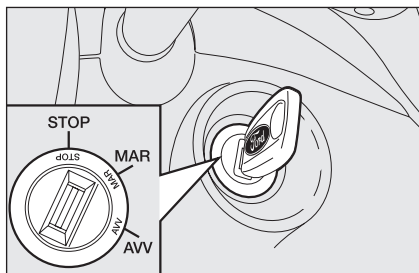

fig. 7

IGNITION SWITCH fig. 7

The key can be turned to 3 different positions:

- STOP:** the engine is off, the key can be extracted, the steering is locked. Some electrical devices (e.g. car radio, central door locking system, etc.) are enabled
- MAR:** driving position. All electrical devices are enabled
- AVV:** engine start.

The ignition device is fitted with a safety system that forces the driver to return the ignition key to **STOP** before repeating the starting operation, if the engine does not start up.

STEERING COLUMN LOCK

Engagement

When the key is at **STOP**, remove the key and turn the steering wheel until it locks.

Disengagement

Rock the steering wheel slightly as you turn the ignition key to **MAR**.



WARNING

Never extract the key while the vehicle is moving. The steering wheel would be locked as soon as the steering wheel is turned. This also applies to when the car is towed.

Any operations in the aftermarket, which would involve tampering with the steering or the steering column (e.g. fitting an anti-theft device), are absolutely prohibited unless they are carried out and authorized by a Ford Dealership; in the addition of a deterioration in the performance of the system, this would affect the warranty and cause serious problems as well as resulting in invalidating the vehicle's type approval.

YOUR CAR

SAFETY

STARTING AND
DRIVINGWARNING
LIGHTS AND
MESSAGESIN AN
EMERGENCYMAINTENANCE
AND CARETECHNICAL
SPECIFICATIONSALPHABETICAL
INDEX

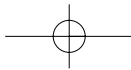

INSTRUMENT PANEL AND ONBOARD INSTRUMENTS

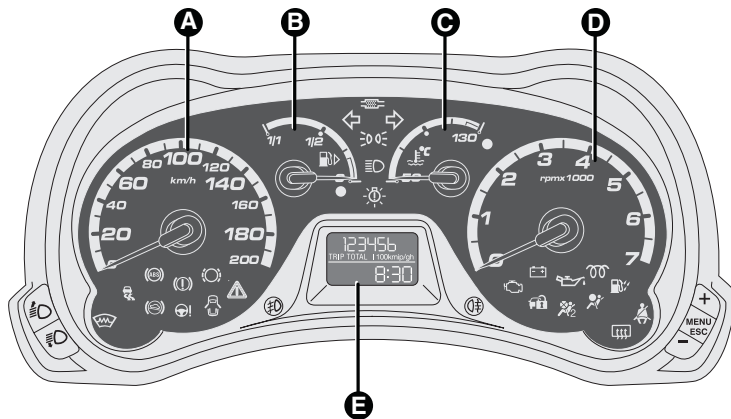

Left-hand drive versions

- A** Speedometer (speed indicator)
- B** Fuel level gauge with reserve warning light
- C** Engine coolant temperature gauge and excessive temperature warning light
- D** Rev counter
- E** Display

Warning lights  and  are available only on Diesel versions.

fig. 8 - Versions with digital display

KA00009m

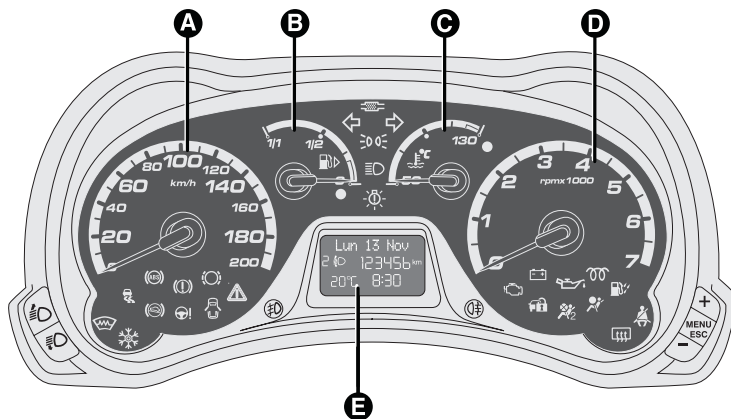

fig. 9 - Versions with multifunctional display

KA00010m

YOUR CAR

SAFETY

STARTING AND DRIVING

WARNING LIGHTS AND MESSAGES

IN AN EMERGENCY

MAINTENANCE AND CARE

TECHNICAL SPECIFICATIONS

ALPHABETICAL INDEX

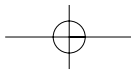

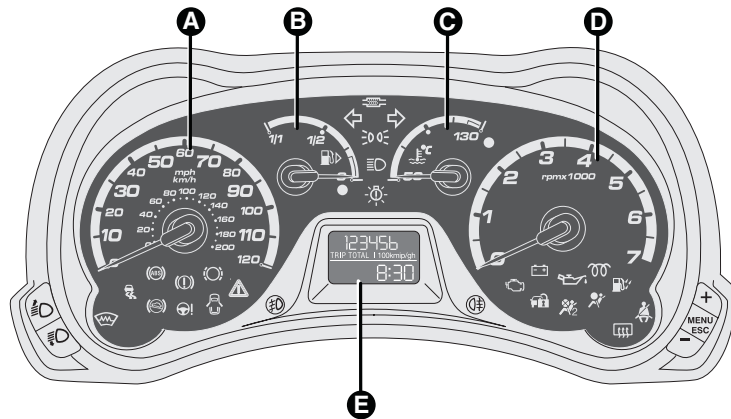

fig. 10 - Versions with digital display

KA00011m

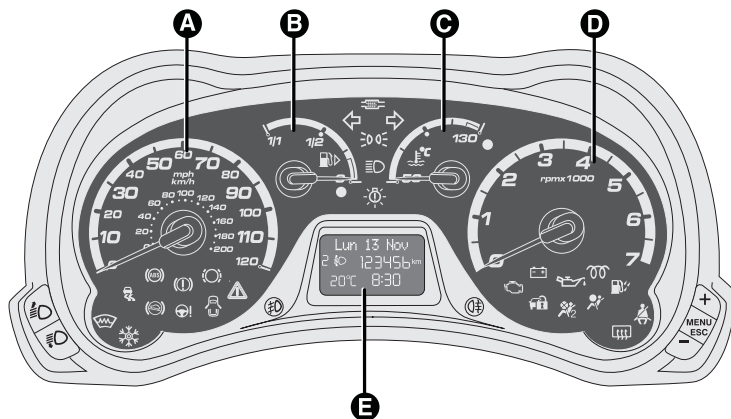

fig. 11 - Versions with multifunctional display

KA00012m

Right-hand drive versions

- A** Speedometer (speed indicator)
- B** Fuel level gauge with reserve warning light
- C** Engine coolant temperature gauge and excessive temperature warning light
- D** Rev counter
- E** Display

Warning lights  and  are present only on Diesel versions.

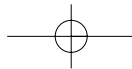

YOUR CAR

Instrument background colour and type may vary according to the version.

SPEEDOMETER

It shows the engine speed.

REV COUNTER

Indicates the engine rpm.

FUEL LEVEL GAUGE

Shows the amount of fuel in the tank.

The reserve warning light turns on to indicate that approximately 5 litres of fuel are left in the tank.

Do not travel with the tank nearly empty: lack of fuel supply could damage the catalyser.

ENGINE COOLANT TEMPERATURE INDICATOR

This shows the temperature of the engine coolant fluid and starts working when the fluid temperature exceeds approx. 50°C.

The warning light may light up (and a message on the multifunctional display may appear in certain versions) to indicate that the coolant temperature is too high; in this case, stop the engine and contact the Ford Dealership.

SAFETY

STARTING AND DRIVING

WARNING LIGHTS AND MESSAGES

IN AN EMERGENCY

MAINTENANCE AND CARE

TECHNICAL SPECIFICATIONS

ALPHABETICAL INDEX

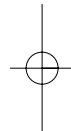
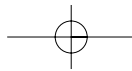

DIGITAL DISPLAY

STANDARD SCREEN fig. 12

The standard screen shows the following information:

- A** Headlight aiming position (only with dipped beam headlights on).
- B** Clock (always displayed, even with ignition key removed and front doors closed).
- C** Odometer (covered km or miles).

Note With key removed (when opening one of the front doors) the display turns on and shows the time and km or miles covered for a few seconds.

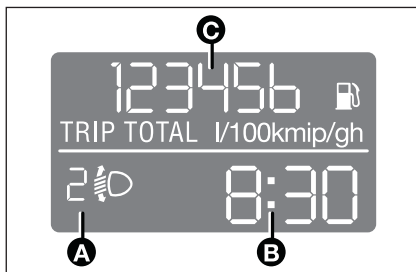

fig. 12

KA00013m

CONTROL BUTTONS fig. 13

+ To scroll the displayed menu and the related options upwards or to increase the value displayed.

MENU ESC Press briefly to display the menu and/or to go to next screen or to confirm the required menu option.

Hold pressed to go back to the standard screen.

- To scroll the displayed menu and the related options downwards or to decrease the value displayed.

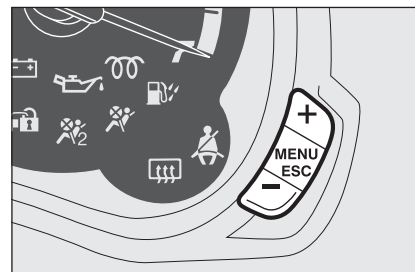

fig. 13

KA00016m

Note Buttons **+** and **-** activate different functions according to the following situations:

Setup menu

- to scroll the menu options upwards and downwards;
- to increase or decrease values during settings.

YOUR CAR

SAFETY

STARTING AND
DRIVINGWARNING
LIGHTS AND
MESSAGESIN AN
EMERGENCYMAINTENANCE
AND CARETECHNICAL
SPECIFICATIONSALPHABETICAL
INDEX

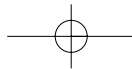

YOUR CAR

SAFETY

STARTING AND
DRIVINGWARNING
LIGHTS AND
MESSAGESIN AN
EMERGENCYMAINTENANCE
AND CARETECHNICAL
SPECIFICATIONSALPHABETICAL
INDEX

SETUP MENU

The menu comprises a series of functions arranged in a cycle which can be selected through buttons **+** and **-** to access the different select operations and settings (setup) given in the following paragraphs.

The setup menu can be activated by pressing briefly button **MENU ESC**.

Single presses on buttons **+** and **-** will scroll the setup menu options.

Handling modes differ with each other according to the characteristic of the option selected.

The menu includes the following functions:

- HOUR
- BUZZ
- SPEED
- UNIT
- P BAG (*)

(*) Function activated only by taking care to dealership.

Selecting a menu option

- press briefly button **MENU ESC** to select the main menu option to set;
- press buttons **+** and **-** (by single presses) to select the new setting;
- briefly press button **MENU ESC** to store the new setting and to go back to the previously selected submenu option.

Selecting "Set Clock"

- briefly press button **MENU ESC** to select the first value to change (hours);
- press buttons **+** and **-** (by single presses) to select the new setting;
- briefly press button **MENU ESC** to store the new setting and go to the next setup menu option (minutes);
- after setting the values with the same procedure, go back to the menu item previously selected.

Hold button MENU ESC pressed:

- to quit the set up menu if you are in the menu;
- to quit the displayed menu if you are setting an option;
- to save the changes to stored settings (and confirmed by pressing button **MENU ESC**).

The setup menu page is timed. Only the changes saved by the user by briefly pressing **MENU ESC** after quitting the menu when this timer has elapsed.

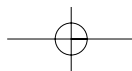

Setting the clock (Hour)

With this function it is possible to set the clock.

To set the required unit proceed as follows:

- briefly press button **MENU ESC**, “hours” will flash on the display;
- press button **+** or **-** for setting;
- briefly press button **MENU ESC**, “minutes” will flash on the display;
- press button **+** or **-** for setting;
- briefly press button **MENU ESC** to go back to the menu screen or press the button for long to go back to the standard screen without storing settings.

Adjusting the buzzer volume (Buzz)

This function is used to adjust the volume of the buzzer triggering in the event of failure/warning indications and when **MENU ESC +** and **-** buttons are pressed.

To adjust the desired volume proceed as follows:

- briefly press button **MENU ESC**, the display will show the wording (bUZZ);
- press button **+** or **-** to select the required volume (volume can be adjusted according to 8 levels).

– briefly press button **MENU ESC** to go back to the menu screen or press the button for long to go back to the standard screen without storing settings.

Setting the speed limit (Speed)

With this function it is possible to set the car speed limit (km/h or mph), when this limit is exceeded the driver is immediately alerted (see section “Warning lights and messages”).

To set the speed limit, proceed as follows:

- briefly press button **MENU ESC**, the message (SPEED) and the previously set unit (km/h) or (mph) will appear on the display;
- press button **+** or **-** to select speed limit activation (On) or deactivation (OFF);
- when the function is activated (On) pressing buttons **+** or **-** select the speed limit and press **MENU ESC** to confirm selection.

Note Selection is possible between 30 and 200 km/h, or 20 and 125 mph depending on the selected unit, see paragraph “Unit of measure”. The setting will increase/decrease by five units each time button **+/-** is pressed. Hold button **+/-** pressed to increase/decrease the setting rapidly. Complete the setting by briefly pressing the button when the required setting is approached.

– briefly press button **MENU ESC** to go back to the menu screen or press the button for long to go back to the standard screen without storing settings.

To cancel the setting, proceed as follows:

- briefly press button **MENU ESC**: (On) will flash on the display;
- press button **-**: (Off) will flash on the display;
- briefly press button **MENU ESC** to go back to the menu screen or press the button for long to go back to the standard screen without storing settings.

YOUR CAR

SAFETY

STARTING AND
DRIVINGWARNING
LIGHTS AND
MESSAGESIN AN
EMERGENCYMAINTENANCE
AND CARETECHNICAL
SPECIFICATIONSALPHABETICAL
INDEX

Setting the distance unit (Unit)

With this function it is possible to set the unit.

To set the required unit proceed as follows:

- briefly press button **MENU ESC**, the display will show the wording (Unit) and the previously set unit (km) or (mi);
- press button **+** or **-** to select the required distance unit.
- briefly press button **MENU ESC** to go back to the menu screen or press the button for long to go back to the standard screen without storing settings.

Front passenger's airbag and side bag activation/deactivation (where provided) (P BAG P)

This function shall be used to activate/deactivate the front passenger's air bag.

Proceed as follows:

- press button **MENU ESC** and, after displaying the message (P BAG OFF) (to deactivate) or the message (P BAG On) (to activate) by pressing buttons **+** or **-**, re-press **MENU ESC**;
- the confirmation request message will be displayed;

- press buttons **+** or **-** to select (YES) (confirming activation/deactivation) or (no) (to abort);
- briefly press the button **MENU ESC** to view a message confirming your selection and go back to the menu screen. Alternatively, press the button for a prolonged time and go back to the standard screen without storing the settings.

(*) Function activated only by taking car to dealership.

MULTIFUNCTIONAL DISPLAY (where provided)

The car can be equipped with the multifunction display that, according to the settings made, will show useful information necessary when driving.

INFORMATION ON "STANDARD" SCREEN fig. 14

The standard screen shows the following information:

- A** Date
- B** Odometer (km or miles travelled).
- C** Time
- D** Outdoor temperature (where provided)
- E** Headlight aiming position (only with dipped beam headlights on).

Note When opening one of the front doors, the display turns on and shows the clock and the kilometres or miles covered for a few seconds.

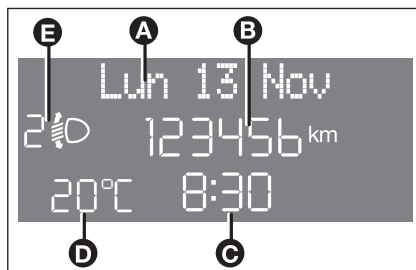

fig. 14

KA00015m

CONTROL BUTTONS fig. 15

+ To scroll the displayed menu and the related options upwards or to increase the value displayed.

MENU ESC Press briefly to display the menu and/or to go to next screen or to confirm the required menu option.

Hold pressed to go back to the standard screen.

- To scroll the displayed menu and the related options downwards or to decrease the value displayed.

Note Buttons **+** and **-** activate different functions according to the following situations:

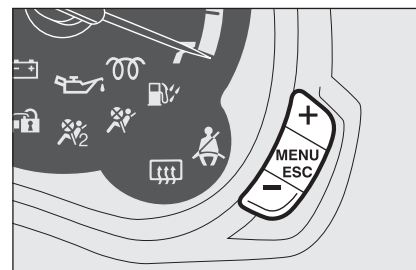

fig. 15

KA00016m

To adjust light inside the passenger compartment

– standard screen, to adjust instrument panel brightness, sound system, and automatic climate control system.

Setup menu

– within the menu, to scroll the menu options upwards and downwards;
– to increase or decrease values during settings.

YOUR CAR

SAFETY

STARTING AND DRIVING

WARNING LIGHTS AND MESSAGES

IN AN EMERGENCY

MAINTENANCE AND CARE

TECHNICAL SPECIFICATIONS

ALPHABETICAL INDEX

YOUR CAR

SAFETY

STARTING AND
DRIVINGWARNING
LIGHTS AND
MESSAGESIN AN
EMERGENCYMAINTENANCE
AND CARETECHNICAL
SPECIFICATIONSALPHABETICAL
INDEX

SETUP MENU

The menu comprises a series of functions arranged in a cycle which can be selected through buttons + and – to access the different select operations and settings (setup) given in the following paragraphs. A submenu is provided for some items (Clock and Unit setting).

The setup menu can be activated by pressing briefly button **MENU ESC**.

Single presses on buttons + or – will scroll the setup menu options.

Handling modes are different according to the characteristic of the option selected.

The menu includes the following functions:

- MENU
- SPEED BEEP
- TRIP B DATA
- TIME SETTING
- DATE SETTING
- SEE RADIO
- MEASUREMENT UNIT
- LANGUAGE
- WARNING VOLUME
- KEY VOL.
- PASSENGER AIRBAG (*)
- COURTESY LIGHTS
- EXIT MENU

(*) Function activated only by taking car to dealership.

Selecting an option of the main menu without submenu

- press briefly button **MENU ESC** to select the main menu option to set;
- press buttons + or – (by single presses) to select the new setting;
- press briefly button **MENU ESC** to store the new setting and go back to the main menu option previously selected.

Selecting an option of the main menu with submenu:

- briefly press button **MENU ESC** to display the first submenu option;
- press buttons + or – (by single presses) to scroll all the submenu options;
- press briefly button **MENU ESC** to select the displayed submenu option and to open the relevant setup menu;
- press buttons + or – (by single presses) to select the new setting for this submenu option;
- briefly press button **MENU ESC** to store the new setting and to go back to the previously selected submenu option.

Selecting “Set Date” and “Set time”:

- Briefly press button **MENU ESC** to select the first value to change (e.g. hours /minutes or year / month / day).
- press buttons + or – (by single presses) to select the new setting;
- briefly press button **MENU ESC** to store the new setting and to go to the next setup menu option, if this is the last one you will go back to the previously selected option of the main menu.

By means of a long press on MENU ESC:

- to quit the set up menu if you are in the main menu;
- to quit the main menu if you are in another point of the menu (e.g.: at submenu option setting level, at submenu level or at main menu option setting level);
- to save the changes to stored settings (and confirmed by pressing button **MENU ESC**).

The setup menu page is timed. Only the changes saved by the user by briefly pressing **MENU ESC** are saved when the menu is automatically closed.

Speed beep (Speed limit)

With this function it is possible to set the car speed limit (km/h or mph); when this limit is exceeded the driver is immediately alerted (see section "Warning lights and messages").

To set the speed limit, proceed as follows:

- briefly press button **MENU ESC**, the display will show the message (Speed Buzz);
- press button **+** or **-** to select speed limit activation (On) or deactivation (Off);
- if the function has been activated (On), press buttons **+** or **-** to select the required speed limit and then press **MENU ESC** to confirm.

Note The speed may be set in the range from 30 to 200 km/h, or from 20 to 125 mph according to the previously chosen unit (see "Setting the distance unit") described below. The setting will increase/decrease by five units each time button **+** / **-** is pressed. Hold button **+** / **-** pressed to increase/decrease the setting rapidly. Complete the setting by briefly pressing the button when the required setting is approached.

– briefly press button **MENU ESC** to go back to the menu screen or press the button for a long time to go back to the standard screen without storing settings.

To cancel the setting, proceed as follows:

- briefly press button **MENU ESC**: (On) will flash on the display;
- press button **-**: (Off) will flash on the display;
- briefly press button **MENU ESC** to go back to the menu screen or press the button for long to go back to the standard screen without storing settings.

Trip B data (tripB on)

Through this option it is possible to activate (On) or deactivate (Off) the Trip B (partial trip) display.

For further information see "Trip computer".

For activation / deactivation, proceed as follows:

- briefly press button **MENU ESC**: (On) or (Off) will flash on the display (according to previous setting);
- press button **+** or **-** for setting;
- briefly press button **MENU ESC** to go back to the menu screen or press the button for long to go back to the standard screen without storing settings.

Setting the time (Clock)

This function enables to set the clock through two sub-menus: "Time" and "Format".

Proceed as follows:

- briefly press button **MENU ESC**, the display will show the two sub-menus "Time" and "Mode";
- press button **+** or **-** to surf the two sub-menus;
- select the required option and then press button **MENU ESC**;
- *when accessing the "Hour" submenu:* briefly press button **MENU ESC**, "hours" will flash on the display;
- press button **+** or **-** for setting;
- briefly press button **MENU ESC**, "minutes" will flash on the display;
- press **+** or **-** to make your choice;

YOUR CAR

SAFETY

STARTING AND
DRIVINGWARNING
LIGHTS AND
MESSAGESIN AN
EMERGENCYMAINTENANCE
AND CARETECHNICAL
SPECIFICATIONSALPHABETICAL
INDEX

– when you are in the “Format submenu: briefly press button **MENU ESC** the previously set display format will flash on the display;

– press button **+** or **–** to select “24h” or “12h”.

When you have made the required settings, briefly press button **MENU ESC** to go back to the menu screen or press the button for long to go back to the standard screen without storing settings.

– hold **MENUESC** pressed to go back to the standard screen or main menu according to the points of the menu where you are at.

Set date (Set Date)

This function enables to update the date (year – month – day).

To update the date proceed as follows:

– briefly press button **MENU ESC**: “day” (dd) will flash on the display;

– press button **+** or **–** for setting;

– briefly press button **MENU ESC**: “month” (mm) will flash on the display;

– press button **+** or **–** for setting;

– briefly press button **MENU ESC**: “year” (yyyy) will flash on the display;

– press button **+** or **–** for setting.

Note The setting will increase or decrease by one unit each time **+** or **–** is pressed. Hold the button pressed to increase/decrease the setting rapidly. Complete the setting by briefly pressing the button when the required setting is approached.

– briefly press button **MENU ESC** to go back to the menu screen or press the button for long to go back to the standard screen without storing settings.

See radio (Repeat audio information)

With this function the display repeats information relevant to the sound system.

– Radio: tuned radio station frequency or RDS message, automatic tuning activation or AutoStore;

– audio CD, MP3 CD: track number;

– CD Changer: CD number and track number.

To activate (On) or to deactivate (Off) sound system info displaying proceed as follows:

– briefly press button **MENU ESC** (On) or (Off) will flash on the display (according to previous setting);

– press button **+** or **–** for setting;

– briefly press button **MENU ESC** to go back to the menu screen or press the button for long to go back to the standard screen without storing settings.

Unit of measure (Set units)

This function may be used to set the measurement unit in three submenus: “Distances”, “Fuel Consumption” and “Temperature”.

To set the required unit proceed as follows:

- briefly press button **MENU ESC** to display the three sub-menus;
- press button **+** or **-** to surf the three sub-menus;
- select the required sub-menu and then press briefly button **MENU ESC**;
- *when accessing the “Distances” submenu:* briefly press **MENU ESC**: either “km” or “mi” will appear on the display (according to the previous setting);
- press button **+** or **-** for setting;
- *when accessing the “Consumption” submenu (where present)* briefly press **MENU ESC**: either “km/l”, “l/100km” or “mpg” will appear on the display (according to the previous setting);

If the distance unit set is “km” the fuel consumption unit will be displayed in km/l or l/100km.

If the distance unit set is “mi” the fuel consumption unit will be displayed in “mpg”.

- press button **+** or **-** for setting;
 - *when accessing the “Temperature” submenu:* briefly press **MENU ESC**: either “°C” or “°F” will appear on the display according to the previous setting;
 - press button **+** or **-** for setting;
- When you have made the required settings, briefly press button **MENU ESC** to go back to the menu screen or press the button for long to go back to the standard screen without storing settings.
- hold **MENU ESC** pressed to go back to the standard screen or main menu according to the points of the menu where you are at.

Language (Selecting the language)

The messages can be displayed in the following languages: Italian, German, English, Spanish, French, Portuguese, Turkish and Dutch.

To set the required language proceed as follows:

- briefly press button **MENU ESC**: the previously set “language” will flash on the display;
- press button **+** or **-** for setting;
- briefly press button **MENU ESC** to go back to the menu screen or press the button for long to go back to the standard screen without storing settings.

YOUR CAR

SAFETY

STARTING AND
DRIVINGWARNING
LIGHTS AND
MESSAGESIN AN
EMERGENCYMAINTENANCE
AND CARETECHNICAL
SPECIFICATIONSALPHABETICAL
INDEX

Buzzer volume (Adjusting the failure/warning buzzer volume)

With this function the volume of the buzzer accompanying any failure/warning indication can be adjusted according to 8 levels.

To adjust the desired volume proceed as follows:

- briefly press button: **MENU ESC**; the previously set volume “level” will flash on the display;
- press button **+** or **–** for setting;
- briefly press button **MENU ESC** to go back to the menu screen or press the button for long to go back to the standard screen without storing settings.

Adjusting the button volume (Button Vol.)

This function may be used to adjust the volume of the beep accompanying the activation of buttons **MENU ESC**, **+** and **–** can be adjusted according to 8 levels.

To adjust the desired volume proceed as follows:

- briefly press button: **MENU ESC**; the previously set volume “level” will flash on the display;
- press button **+** or **–** for setting;
- briefly press button **MENU ESC** to go back to the menu screen or press the button for long to go back to the standard screen without storing settings.

Passenger bag Front passenger’s airbag and side bag activation/ deactivation (where provided)

This function shall be used to activate/deactivate the front passenger’s air bag.

Proceed as follows:

- briefly press button **MENU ESC** and, after displaying the message “Bag pass: Off) (to deactivate) or Bag pass: On) (to activate) by pressing the buttons **+** and **–**, press the button **MENU ESC** again;
- the confirmation request message will be displayed;
- press buttons **+** or **–** to select (Yes) (confirming activation/deactivation) or (No) (to abort);
- briefly press **MENU ESC** to confirm setting and go back to the menu screen or press the button for long to go back to the standard screen without storing settings.

Courtesy lights (Greeting lights)

This functions allows the side lights and number plate lights to be turned on when the doors or boot are opened using the remote control, with the following exceptions:

- interruption 5 seconds following door closure
- Interruption after a lock command from the remote control
- Interruption after a lock or activation command from the remote control

For activation/deactivation, proceed as follows:

- briefly press button **MENU ESC**: (On) or (Off) will flash on the display (according to previous setting);
- press button **+** or **-** for setting;
- briefly press button **MENU ESC** to go back to the menu screen or press the button for long to go back to the standard screen without storing settings.

Exit Menu

This is the last function that closes the setting cycle listed in the initial menu screen.

Briefly press button **MENU ESC** to go back to the standard screen without storing settings.

Press button **-** to return to the first menu option (Speed Beep).

YOUR CAR

SAFETY

STARTING AND
DRIVINGWARNING
LIGHTS AND
MESSAGESIN AN
EMERGENCYMAINTENANCE
AND CARETECHNICAL
SPECIFICATIONSALPHABETICAL
INDEX

TRIP COMPUTER

General features

The “Trip computer” is used to display information on car operation when the key is turned to **MAR**. This function allows to define two separate trips called “Trip A” and “Trip B” for monitoring the car’s “complete mission” in a reciprocally independent manner.

Both functions are resettable (reset - start of new mission).

“Trip A” shall be used to display the figures relating to:

- Range
- Distance
- Average consumption
- Instant consumption
- Average speed
- Travel time (driving time).

“Trip B” shall be used to display the figures relating to:

- Distance B
- Average consumption B
- Average speed B
- Travel time B (driving time)
- Reset trip B

Note “Trip B” may be excluded. “Range” and “Instantaneous fuel consumption” cannot be reset.

Values displayed

Range

This indicates the distance which may be travelled with the fuel in the tank assuming that driving conditions will not change. The message “----” will appear on the display in the following cases:

- value lower than 50 km (or 30 mi)
- the car is parked with the engine running for a long time.

IMPORTANT The range depends on several factors: driving style (see paragraph “Driving style” in section “Starting and driving”), type of route (motorway, urban cycle, mountain roads, etc...), conditions of use of the vehicle (load, tyre pressure, etc...). Trip planning must take into account the above notes.

Trip distance

This value shows the distance covered from the start of the new mission.

Average consumption

This value shows the approximate average consumption from the start of the new mission.

Instant consumption

This indicates the fuel consumption. The value is constantly updated. The message “----” will appear on the display if the car is parked with the engine running.

Average speed

This value shows the car average speed as a function of the overall time elapsed since the start of the new mission.

Travel time

This value shows the time elapsed since the start of the new mission.

TRIP button fig. 16

Button **TRIP**, set on the right steering column stalk, shall be used (with ignition key on **MAR**) to display and to reset the previously described values to start a new mission:

- short push to display the different values;
- long pressing to reset and then start a new mission.

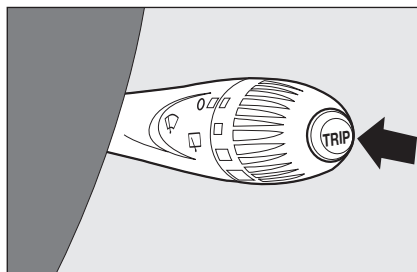

fig. 16

KA00017m

New mission

The new mission begins after:

- “manual” resetting by the user, by pressing the relevant button;
- “automatic” resetting, when the “Trip distance” reaches 9999.9 km or when the “Travel time” reaches 99.59 (99 hours and 59 minutes);
- disconnection/reconnection of the battery.

IMPORTANT The reset operation in the presence of the screens concerning the “Trip A” makes it possible to reset only the information associated with this function.

IMPORTANT The reset operation in the presence of the screens concerning the “Trip B” makes it possible to reset only the information associated with this function.

“Start trip” procedure

With ignition key on **MAR**, press and hold button **TRIP** pressed for over 2 seconds to reset.

Exit Trip

The **TRIP** function is over when all the values have been displayed or holding the button **MENU ESC** pressed for longer than 1 second.

YOUR CAR

SAFETY

STARTING AND
DRIVINGWARNING
LIGHTS AND
MESSAGESIN AN
EMERGENCYMAINTENANCE
AND CARETECHNICAL
SPECIFICATIONSALPHABETICAL
INDEX

SEATS

FRONT SEATS



WARNING

All adjustments must be made with the car stationary.

Fore/aft adjustment fig. 17

Lift lever **A** and push the seat forwards and backwards.



WARNING

After releasing the adjustment lever, always check that the seat is locked on the runners by trying to move it back and forth. If it is not locked, the seat may move unexpectedly and make you lose control of the car.

Heated seats fig. 17 (where provided)

Press button **E** to switch the seat warming on/off.

ATTENTION Operating the heated seats with the engine off will drain the battery.

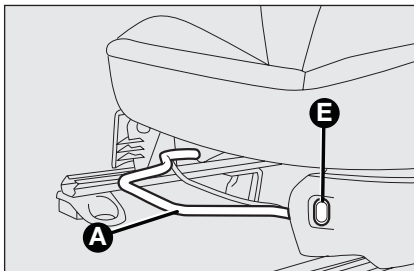

fig. 17

KA00006m

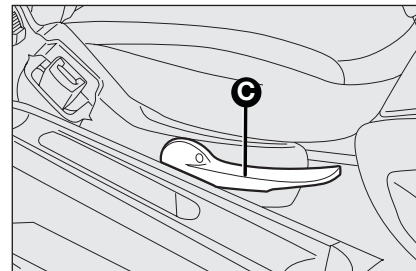

fig. 19

KA00008m

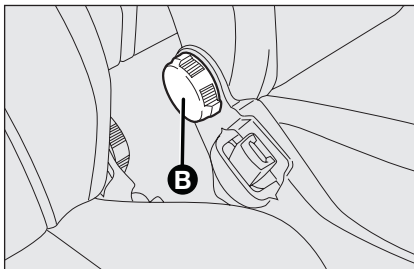

fig. 18

KA00007m

Back rest angle adjustment fig. 18

Turn knob **B**.

Seat height adjustment (where provided) fig. 19

Operate lever **C** to lift or lower the rear area of the cushion to achieve the most comfortable driving position.

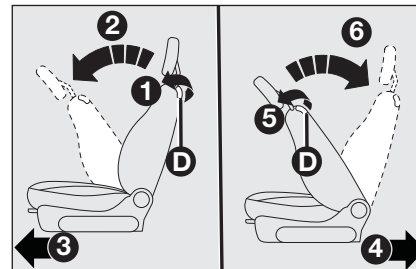

fig. 20

KA00018m

Backrest tilting fig. 20

To tilt the seat, operate lever **D** (movement ①) and push the backrest forward to lock (movement ②); release lever **D** and push the backrest to slide the seat forward (movement ③, applies only to seats with easy entry).

Driver side, where equipped with position memory

To return the seat to its initial position, slide the seat back and press on the backrest to lock the seat (movement ④) operate lever **D** (movement ⑤) and raise the backrest (movement ⑥) until it clicks home.

ATTENTION Using lever **D** before locking the seat in its original position causes the original seat position to be lost. In this case, adjust the seat position by means of the reach adjustment **fig. 17**.

Driver side and passenger side where not equipped with position memory

To return the seat to its initial position, slide the seat back and press on the backrest to lock the seat (movement ④) operate lever **D** (movement ⑤) and raise the backrest (movement ⑥) until it clicks home. Adjust reach using lever **A**-**fig. 17**.



WARNING

All adjustments must be made with the car stationary.

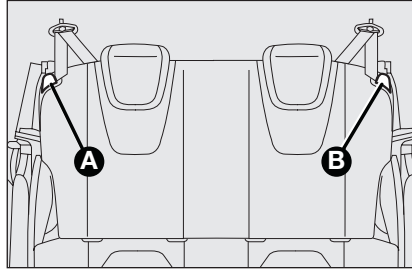

fig. 21

The type of reattachment movement was chosen to ensure occupant safety. If an obstacle is present (e.g. a bag) and the seat cannot be returned to its original position, it re-attaches the seat even when only the backrest is positioned to ensure the guides are always locked.

REAR SEATS **fig. 21**

Backrest release

- For versions with joint seat, lift handles **A** and **B** and guide the backrest onto the cushion.
- For versions with separate seats, lift handle **A** or **B** to release respectively the left or right part of the backrest and guide the backrest onto the cushion.

HEADRESTS

HEAD RESTRAINTS **fig. 22**

Head restraints height can be adjusted as follows.

- upward adjustment: raise the head restraint until you hear it click.
- Downward adjustment: press **A** and lower the head restraint.



WARNING

Perform these operations only when the car is stationary and the engine is not running.

The head restraints should be adjusted to support the back of your head and not your neck. Only in this position do they exert their protective action.

To optimise head restraint protective action, adjust the backrest upright and keep your head as close as possible to the head restraint.

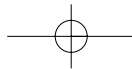

YOUR CAR

SAFETY

STARTING AND
DRIVINGWARNING
LIGHTS AND
MESSAGESIN AN
EMERGENCYMAINTENANCE
AND CARETECHNICAL
SPECIFICATIONSALPHABETICAL
INDEX

fig. 22

KA00020m

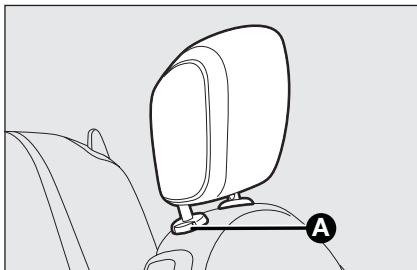
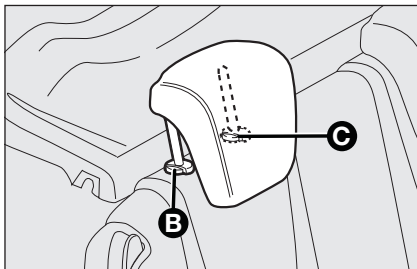

fig. 23

KA00021m

REAR HEAD RESTRAINTS (where provided) fig. 23

To lift out rear head restraints: press at the same time buttons **B** e **C** set on both sides and take them out. The rear head restraint must be removed with the backrest released and tilted toward the passenger compartment. To restore the backrest to its service condition, raise until it clicks home.

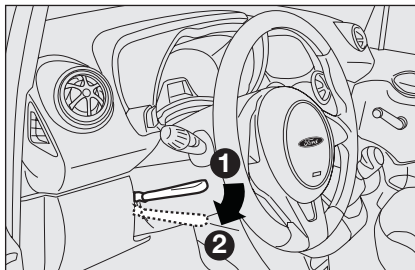

fig. 24

KA00113m

To lower the backrest, press button **B**. The specific shape of the head restraint interferes with the correct rest of the back of the rear passenger on the backrest; the shape is useful to force the passenger to lift the headrest for its correct use.

IMPORTANT Rear seat passengers shall always set the head restraints in “fully drawn out” position.

STEERING WHEEL

It can be adjusted vertically (where provided).

For adjustment, bring the lever **fig. 24** downward to position **2** then position the wheel and lock it bringing lever to position **1**.



WARNING

Perform these operations only when the car is stationary and the engine is not running.

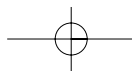

REARVIEW MIRRORS

DRIVING MIRROR fig. 25

The mirror is fitted with a safety device that causes its release in the event of a violent crash. It can be moved using lever **A** to two different positions: normal or antiglare.

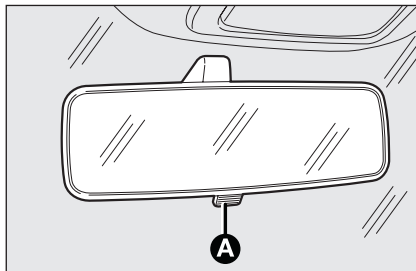

fig. 25

KA00022m

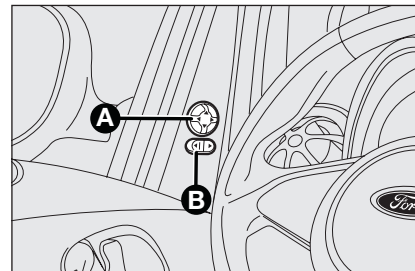

fig. 26b

KA00023m

DOOR MIRRORS

With electrical adjustment fig. 26a

From the inside of the car, operate lever **A** to adjust the mirror.

With electrical adjustment fig. 26b

Proceed as follows:

- select the mirror with selector **B**;
- adjust the mirror using the joystick **A** in the four directions.

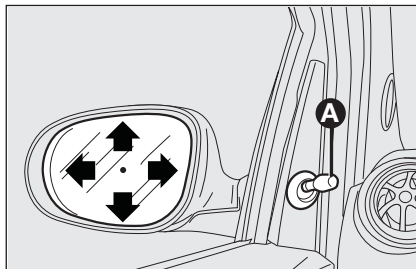

fig. 26a

KA00116m

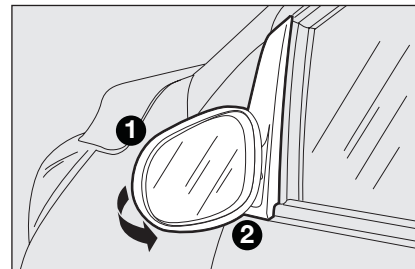

fig. 27

KA00024m

Folding back door mirrors fig. 27

When required (for example when the mirror causes difficulty in narrow spaces) it is possible to fold the mirror moving it from position **1** open, to position **2** closed.



WARNING

When driving, the mirrors shall always be in position 1.



WARNING

The door mirrors, being curved, slightly alter the perception of distance.

CLIMATE COMFORT

VENTS fig. 28

1. Vents for demisting/defrosting the windscreen
2. Orientable, adjustable central vents
3. Orientable, adjustable side vents
4. Fixed vents for side windows.
5. Lower vents

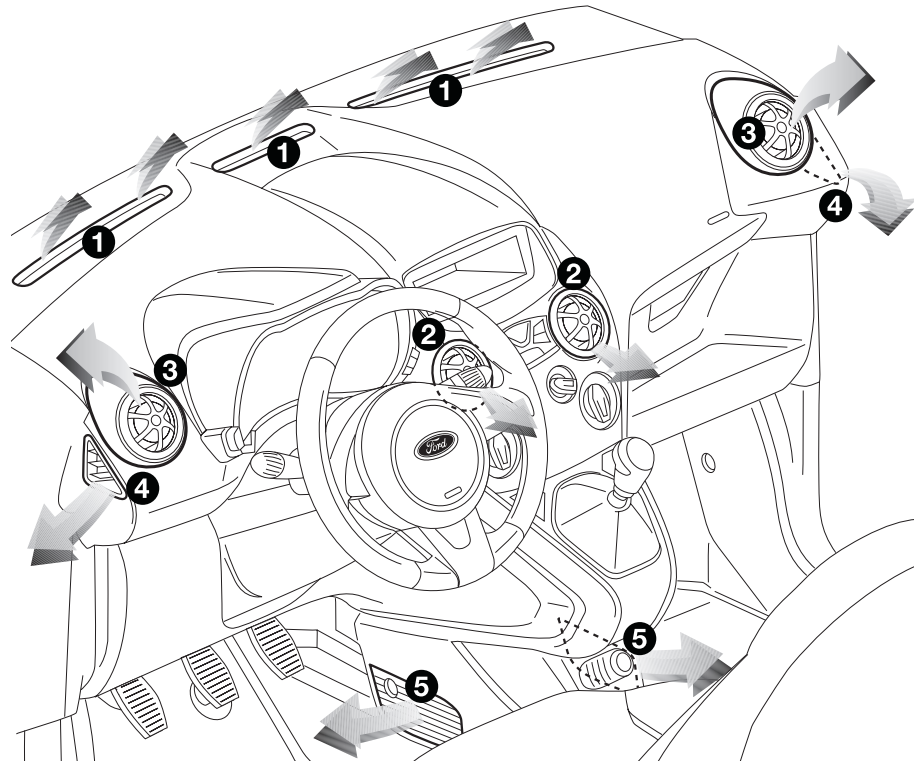

fig. 28

KA00025m

HEATING AND VENTILATION

CONTROLS fig. 29

A Air temperature knob (red-hot / blue-cold)

B Fan speed knob

C Air recycle knob

 – internal air recycle

 – air intake from outside

IMPORTANT It is advisable to activate air recycle in queues or in tunnels to prevent the introduction of polluted air. Do not use the function for a long time, particularly if there are many passengers on board, to prevent the windows from misting up.

D Air distribution knob

 toward the body and the side windows

 toward the body, the side windows and the feet

 toward the feet only

 toward the feet and the windshield

 toward the windscreen only

E Heated rear screen activation/deactivation button. When the function is active, a warning light  on the instrument panel is on.

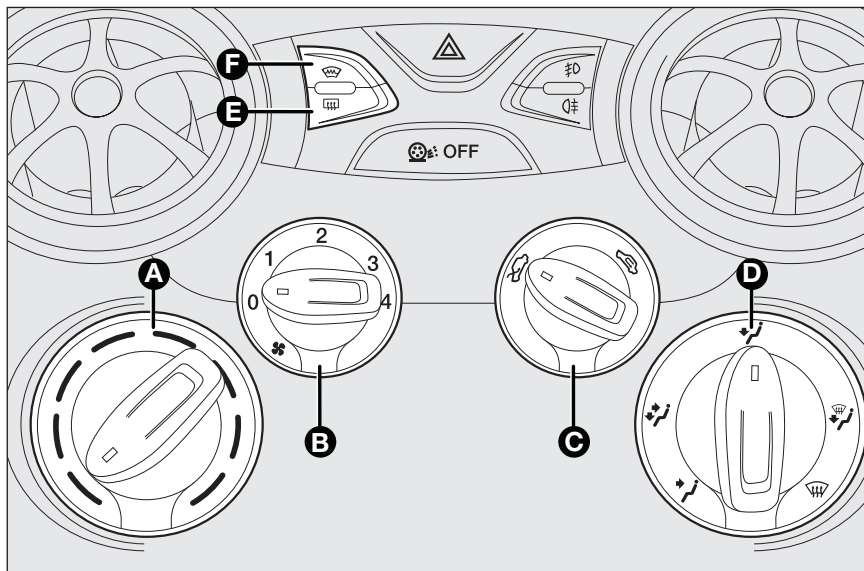



fig. 29

KA00026m



In order to maintain battery efficiency, the function is automatically deactivated after about 4 minutes.

F Heated rear screen activation/deactivation button (possible only with engine started). When the function is active, a warning light  on the instrument panel is on.

In order to maintain battery efficiency, the function is automatically deactivated after about 20 minutes.

Fast front window demisting/defrosting

Proceed as follows:

- rotate knob **A** to red section;
- rotate knob **C** to .
- rotate knob **D** to .
- rotate knob **B** to 4  (max. fan speed).

YOUR CAR

SAFETY

STARTING AND DRIVING

WARNING LIGHTS AND MESSAGES

IN AN EMERGENCY

MAINTENANCE AND CARE

TECHNICAL SPECIFICATIONS

ALPHABETICAL INDEX

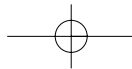

MANUAL CLIMATE CONTROL SYSTEM (where provided)

CONTROLS fig. 30

- A** Air temperature knob (red-hot / blue-cold)
- B** Fan speed knob and climate control system activation/deactivation. Press the knob to activate the climate control system; the led on the knob is active. This enables passenger compartment quick cooling.
- C** Air recycle knob
- internal air recycle
 - air intake from outside

IMPORTANT It is advisable to activate air recycle in queues or in tunnels to prevent the introduction of polluted air. Do not use the function for a long time, particularly if there are many occupants on board, to prevent the windows from misting up.

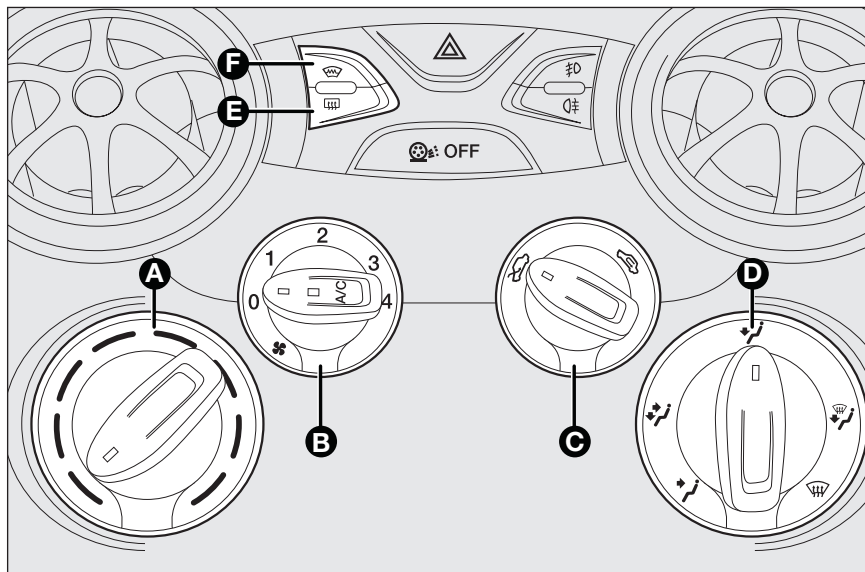

fig. 30

KA00027m

- D** Air distribution knob
- toward the body and the side windows
 - toward the body, the side windows and the feet
 - toward the feet only
 - toward the feet and the windshield
 - toward the windscreen only
- E** Heated rear screen activation/deactivation button. Activation is indicated by lighting of warning light on the instrument panel

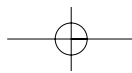

In order to maintain battery efficiency, the function is automatically deactivated after about 20 minutes.

- F** Heated rear screen activation/deactivation button (possible only with engine started). When the function is active, a warning light on the instrument panel is on. In order to maintain battery efficiency, the function is automatically deactivated after about 4 minutes.



Fast front window and front side windows demisting/defrosting (MAX-DEF)

Proceed as follows:

- rotate knob **A** to red section;
- rotate knob **C** to ;
- rotate knob **D** to ;
- rotate knob **B** to 4  (max. fan speed).

IMPORTANT the climate control system is very useful to accelerate demisting, because it dehumidifies the air. Adjust the controls as described above and press knob **B** to switch the climate control system on: the LED on the knob will light up.

LOOKING AFTER THE SYSTEM

Run the climate control system for at least 10 minutes every month during the winter. Have the system inspected at a Ford Dealership before the summer.

YOUR CAR

SAFETY

STARTING AND
DRIVING

WARNING
LIGHTS AND
MESSAGES

IN AN
EMERGENCY

MAINTENANCE
AND CARE

TECHNICAL
SPECIFICATIONS

ALPHABETICAL
INDEX

AUTOMATIC CLIMATE CONTROL SYSTEM (where provided)

According to the temperature set by the user, the automatic climate control system automatically adjusts:

- the temperature of the air sent to the passenger compartment;
- fan speed (continuous air flow variation);
- the distribution of air inside the passenger compartment;
- compressor activation/deactivation (to cool/dehumidify air);
- air recycle activation/deactivation;

All functions can be manually changed. In other words, you may operate the system selecting one or more functions. The manual setting of a function does not impair the automatic control of the other functions even if the led of the knob **AUTO** is off.

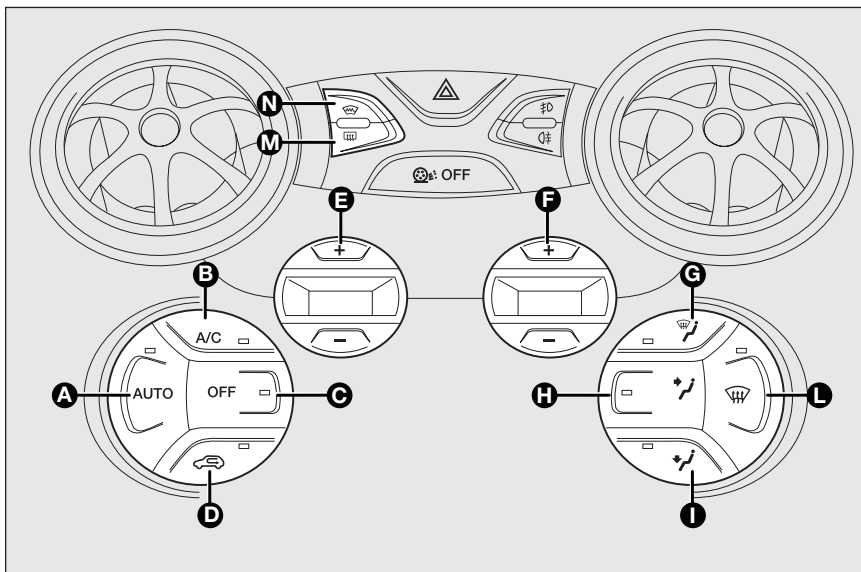

fig. 31

KA00028m

CONTROLS fig. 31

Button **AUTO** - A Activation of the automatic function of the climate control system

Pressing the button **AUTO** and setting the temperature, the system adjusts the temperature, the quantity and distribution of the air into the passenger compartment and controls the activation of the compressor.

A/C button - B compressor activation/deactivation

Pressing the button, with led on, the compressor and the led switch off.

When the compressor is off:

- the system deactivates air recycle to avoid window misting;

- it is not possible to supply into the passenger compartment air with a temperature lower than external air temperature (the temperature indicated on the display blinks when the system does not ensure the achievement of the required comfort conditions);
- it is possible to manually reset the fan speed (with compressor enabled, ventilation cannot go below a bar shown on the display).

Button OFF - C System switch off

Pressing the button **OFF** the system is switched off.

The following climate control conditions will be established when the system is off:

- all LEDs off;
- set temperature display off;
- air recycle off;
- compressor off;
- fan off.

In this condition, it is possible to enable or disable air recycle without system activation.

Button - D Air recycle on/off button

It is advisable to switch internal air recirculation on while standing in queues or in tunnels to prevent the introduction of polluted air.

Led on button ON = recycle ON.

Led on button OFF = recycle OFF.

For low temperatures or if the compressor is off, the recycle is forced to off to avoid misting.

IMPORTANT It is advisable not to use the air recycle function when the outside temperature is low, to prevent the windows from rapidly misting up.

Buttons +, -, E Setting desired temperature

Pressing the button **+** the temperature in the passenger compartment rises until the value HI is reached (maximum heating).

Pressing the button **-** the temperature in the passenger compartment decreases until the value LO is reached (maximum cooling).

IMPORTANT Specifically, if the heating fluid is not sufficiently warm, the fan will not start up at the maximum speed immediately to limit introducing excessively cool air into the passenger compartment.

Buttons +, -, F Adjusting fan speed



Pressing the buttons **+** or **-** respectively, the fan speed displayed on the display bars increases or decreases.

The fan can be cut off only if the compressor has been switched off (button **B**).

To restore automatic fan speed control, press button **AUTO**.

Buttons - G H I Manual air distribution selection

Pressing the buttons, it is possible to set one of 5 different air flow options:

-  to the windscreen and front side window vents to demist or defrost them.
-  Air flow at central and side dashboard vents to ventilate the chest and the face during the hot season.

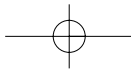

YOUR CAR

SAFETY

STARTING AND DRIVING

WARNING LIGHTS AND MESSAGES

IN AN EMERGENCY

MAINTENANCE AND CARE

TECHNICAL SPECIFICATIONS

ALPHABETICAL INDEX

toward front seat footwell diffusers. The natural tendency of hot air to spread upwards, allows to warm the passenger compartment up as quickly as possible, providing an immediate feeling of warmth.

distribution between feet area vents (warmer air) and dashboard vents (cooler air).

distribution between feet area vents and windscreen and front side window vents). This distribution allows an adequate warming of the passenger compartment and prevents the windows from misting up.

The set distribution is shown by the LEDs on the selected buttons.

To restore automatic air distribution control, press button **AUTO**.

Button - L

Front window fast demisting/defrosting button

Pressing the button the system activates all the functions required for fast demisting/defrosting:

compressor switch on (if climatic conditions are suitable);

- air recycle off;
- air temperature set to maximum (HI);
- fan speed selection depending on coolant temperature;
- air flow toward the windshield and the front side windows;
- heated rear window on;
- heated rear window on (if present).

IMPORTANT The function stays on for approximately 3 minutes once the coolant is sufficiently warm

DEMISTING/DEFROSTING HEATED REAR WINDOW

Press button **M** to activate this function. Activation is indicated by lighting of warning light on the instrument panel.

This function is timed and it will turn off automatically after 20 minutes. Press button **M** again to disable the function in advance.

IMPORTANT Do not affix decals on the inside of the rear window over the heating filaments to avoid damage that might cause it to stop working properly.

DEMISTING/DEFROSTING HEATED REAR WINDOW

Press button **N** to activate this function. Activation is indicated by lighting of warning light on the instrument panel.

This function is timed and it will turn off automatically after 4 minutes. Press button **N** again to disable the function in advance.

LOOKING AFTER THE SYSTEM

Run the climate control system for at least 10 minutes every month during the winter.

Have the system inspected at a Ford Dealership before the summer.



The system uses R134a refrigerant fluid which does not harm the environment in the event of accidental leakage. Never use R12 fluid which is not compatible with the system components.

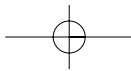

EXTERNAL LIGHTS

The left-hand stalk operates most of the external lights. The external lights can only be switched on when the ignition key is on **MAR**. The instrument panel and the various controls on the dashboard will come on when the external lights are switched on.

Lights off fig. 32

Knurled ring turned to symbol .

SIDE LIGHTS fig. 32

Turn the knurled ring to position .

The warning light  on the instrument panel will come on.

DIPPED BEAMS fig. 32

Turn the knurled ring to position .

The warning light  on the instrument panel will come on at the same time.

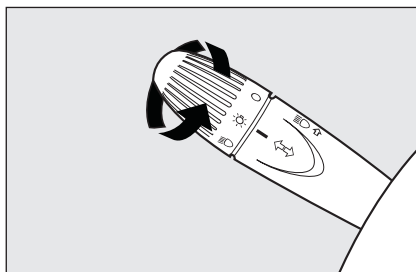





fig. 32

KA00108m

MAIN BEAMS fig. 32

With knurled ring in position , push the stalk forward toward the dashboard (steady position). The warning light  on the instrument panel comes on at the same time. They switch off pulling the stalk toward the wheel (low beams turn on).

FLASHING fig. 32

You can flash the beams pulling the stalk toward the wheel (unstable position). The warning light  on the instrument panel will come on at the same time.

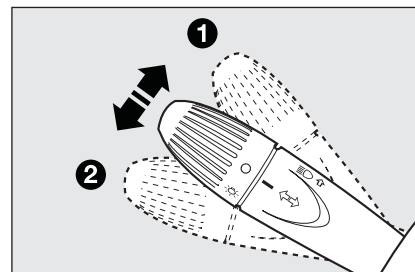



fig. 33

KA00109m

DIRECTION INDICATORS fig. 33

Push the stalk to (stable) position:
up (position **1**): right-hand indicator ON;
down (position **2**): left-hand indicator ON.

Warning light  or  will blink on the instrument panel. Indicators are switched off automatically when the steering wheel is straightened.

Lane change function

If you want to signal that you are changing lane, bring the left stalk in unstable position for shorter than half a second. The direction indicator on the selected side flashes three times and then switches off automatically.

YOUR CAR

SAFETY

STARTING AND
DRIVINGWARNING
LIGHTS AND
MESSAGESIN AN
EMERGENCYMAINTENANCE
AND CARETECHNICAL
SPECIFICATIONSALPHABETICAL
INDEX

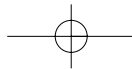

“FOLLOW ME HOME” DEVICE

This function allows the illumination of the space in front of the car for a preset period of time.

Activation

With the ignition key on **STOP** or removed, pull the stalk towards the steering wheel within 2 minutes from when the engine is turned off.

At each single movement of the stalk, the staying on of the lights is extended by 30 seconds up to a maximum of 210 seconds; then the lights are switched off automatically.

Each time the stalk is operated, the warning light  on the instrument panel turns on and the display shows how long the function remains active.

The warning light turns on the first time the stalk is operated, and stays on until the function is automatically deactivated. Each time you operate the lever, only the permanence of lights increases.

Deactivation

Keep the stalk pulled towards the steering wheel for more than 2 seconds.

WINDOW WASHING

The right stalk **fig. 34** controls windscreen wiper/washer and heated rear window wiper/washer operation.

WINDSCREEN WASHER/WIPER

The device can work only when the ignition key is on **MAR**.

The stalk has 5 different positions (4 speeds):

- A** windscreen wiper off.
- B** intermittent.
- C** continuous slow.
- D** continuous fast.
- E** temporary fast (unstable position).

The temporary fast function lasts as long as you manually keep the stalk in that position. When released, the stalk will return to position **A** and the wiper will be automatically stopped.

“Smart washing” function

Pull the stalk towards the steering wheel (unstable position) to operate the windscreen washer jet.

Keep the stalk pulled to activate with a single movement the windscreen washer jet and the windscreen wiper; the latter automatically turns on if you keep the stalk pulled for over half a second. The windscreen wiper stops

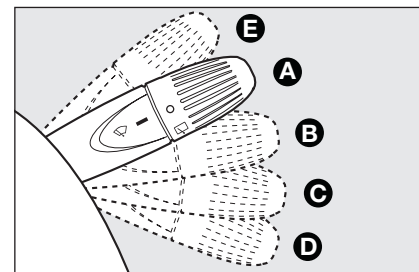

fig. 34

KA00111m

operating a few strokes after releasing the stalk; a further “cleaning stroke”, after a few seconds, completes the wiping operation.



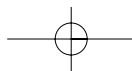

Do not use the windscreen wiper to remove layers of snow or ice from the windscreen. In such conditions, the windscreen wiper may be subjected to excessive stress and the motor protection which prevents operation for a few seconds may trip. If rear window wiper operation is not reset, contact the Ford Dealership.



REAR WINDOW WIPER/ REAR WINDOW WASHER

The device can work only when the ignition key is on **MAR**.

Turn the knurled ring to  to operate the rear window wiper.

With the windscreen wiper active, rotate the knurled ring to  to activate the rear window wiper which, in this case, operates (in the different positions) in synch with the windscreen wiper, yet with half its frequency. With windscreen wiper active, engaging reverse gear, the rear window wiper automatically turns on in slow continuous mode.

It stops when the reverse gear is disengaged.



Do not use the rear window wiper to remove layers of snow or ice from the rear window. In such conditions, the rear window wiper may be subjected to excessive stress and the motor protection which prevents operation for a few seconds may trip. If the function is not reset, contact the Ford Dealership.

“Smart washing” function

Pushing the stalk towards the dashboard (unstable position) will activate the rear window washer.

Keep the stalk pushed to activate with a single movement the rear window washer jet and the rear window wiper; the latter automatically turns on if you keep the stalk pushed for over half a second.

The rear window wiper stops operating a few strokes after releasing the stalk; a further “cleaning stroke”, after a few seconds, completes the wiping operation.

YOUR CAR

SAFETY

STARTING AND
DRIVINGWARNING
LIGHTS AND
MESSAGESIN AN
EMERGENCYMAINTENANCE
AND CARETECHNICAL
SPECIFICATIONSALPHABETICAL
INDEX

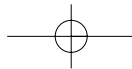

YOUR CAR

SAFETY

STARTING AND DRIVING

WARNING LIGHTS AND MESSAGES

IN AN EMERGENCY

MAINTENANCE AND CARE

TECHNICAL SPECIFICATIONS

ALPHABETICAL INDEX

CEILING LIGHTS

FRONT CEILING LIGHT

The lens can be set to three positions:

- right side pressed: light always off
- left side pressed: light always on
- central position (neutral): the light turns on and off when the doors are opened or closed.

IMPORTANT Before getting out of the car, make sure the switch is on the central position: ensure that lights are off with doors closed in order to avoid draining the battery.

On same versions, light switch on and off occur only when the front driver side door is opened or closed.

When the doors are released with the remote control, a timer will be activated for 10 seconds. When locking the doors using the remote control, the courtesy light goes off.

Ceiling light timing (central position of the lens)

Three different switch on modes are foreseen:

- when opening one door, a three minute timing is set;
- when removing the key from the ignition switch within two minutes from engine switch off, a 10 second timing is set;
- when doors are unlocked (either with remote control or with key on driver side door), a 10 second timing is set.

Three modes are foreseen for switch off:

- when closing all doors, a three minute timing is set; The timing is disabled if the key is moved to **MAR**;
- when doors are locked (either with remote control or with key on driver side door), the ceiling light turns off.
- the courtesy lights are turned off in any case after 15 minutes to preserve battery duration

BOOT LIGHT

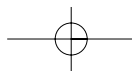

For versions fitted with boot light, it will turn on automatically when opening the tailgate and it will turn off at closing. The boot courtesy light has a 15 minute timer.



CONTROLS FOR

HAZARD LIGHTS fig. 35

They turn on by pressing switch **A**, regardless of the position of the ignition key.

With the device on, warning lights  and  light up on the instrument panel.

To switch off, press button **A** again.

The use of hazard lights is governed by the Highway Code of the country you are in. Keep to the rules.

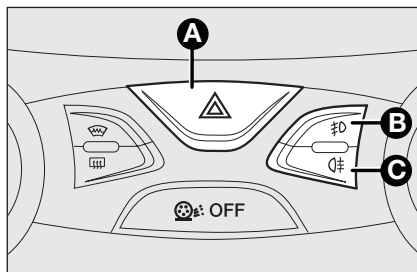



fig. 35

KA00029

Emergency braking

During emergency braking, the emergency lights come on automatically and simultaneously warning lights  and  light up on the panel.

The function turns off automatically when the braking is no longer an emergency manoeuvre.

This function complies with relevant legal regulations currently in force.

FRONT FOG LIGHTS (where provided) fig. 35

These come on with the side lights/dipped beams on by pressing button **B**; warning light  lights up on the instrument panel. The use of fog lights is governed by the Highway Code of the country you are in. Keep to the rules.

YOUR CAR

SAFETY

STARTING AND DRIVING

WARNING LIGHTS AND MESSAGES

IN AN EMERGENCY

MAINTENANCE AND CARE

TECHNICAL SPECIFICATIONS

ALPHABETICAL INDEX

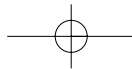

YOUR CAR

SAFETY

STARTING AND DRIVING

WARNING LIGHTS AND MESSAGES

IN AN EMERGENCY

MAINTENANCE AND CARE

TECHNICAL SPECIFICATIONS

ALPHABETICAL INDEX

REAR FOG LIGHTS fig. 35

Press button **C**, to turn these lights on if it is necessary to have the dipped beam headlights or the front fog lights (where provided) switched on.

With lights on, the warning light  on the instrument panel will come on at the same time. Press the button again to turn the lights off.

FUEL CUT-OFF SYSTEM

This system triggers after a collision and activates the following:

- switch off of fuel supply with consequent engine switch off;
- automatic door unlocking;
- switch on of all lights inside the vehicle.

When the system is active, the message “Fuel cut-off see handbook” is displayed.

Carefully check the car for fuel leaks, for instance in the engine compartment, below the car or near the tank area.

After a crash, turn the ignition key to **STOP** to avoid draining the battery.

Observe the following procedure to restore correct vehicle operation:

- turn the ignition key to **MAR**;
- activate the right-hand indicator;
- deactivate the right-hand indicator;
- activate the left-hand indicator;
- deactivate the left-hand indicator;

- activate the right-hand indicator;
- deactivate the right-hand indicator;
- activate the left-hand indicator;
- deactivate the left-hand indicator;
- turn the ignition key to **STOP**.

The procedure is guided by the direction indicator warning lights on the control panel.



WARNING

If, after a crash, you smell fuel or notice leaks from the fuel system, do not reset the system to avoid fire risk.

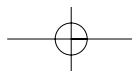

INTERIOR FITTINGS

CIGAR LIGHTER (where provided) fig 36



WARNING

The cigar lighter becomes very hot. Handle with care. The device must not be used by children: risk of fire or burns. Always check that the cigar lighter has turned off.

SUN VISORS

These are arranged at the sides of the internal rearview mirror.

They may be oriented frontally and to the side.

A courtesy mirror is applied to the back of the driver side visor.

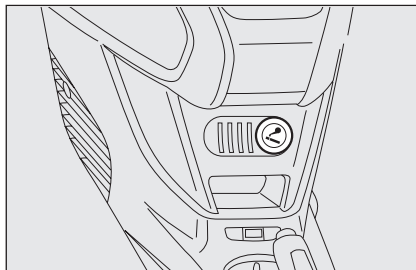

fig. 36

KA00122m

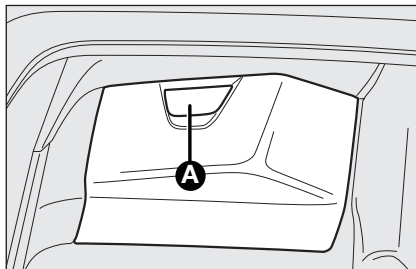

fig. 37

KA00040m

PASSENGER SIDE GLOVE COMPARTMENT fig. 37

To open the glove box, operate opening device **A**.



WARNING

Do not travel with the oddment compartments open: they could hurt the passenger in case of crash.

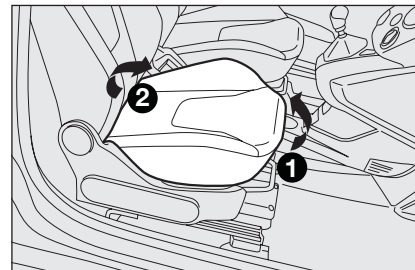

fig. 38

KA00031m

ODDMENT COMPARTMENT UNDER THE SEAT (where provided) fig. 38

In some versions, under the passenger seat there is an oddment compartment.

To access the oddment compartment, lift the front area of the cushion **1** to enable its release, then lift the rear area **2** (backseat side).

To close the oddment compartment, lower and insert under the backrest the rear of the cushion without forcing, then press on the front of the cushion until it snaps in position.

YOUR CAR

SAFETY

STARTING AND DRIVING

WARNING LIGHTS AND MESSAGES

IN AN EMERGENCY

MAINTENANCE AND CARE

TECHNICAL SPECIFICATIONS

ALPHABETICAL INDEX

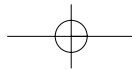

YOUR CAR

SAFETY

STARTING AND
DRIVINGWARNING
LIGHTS AND
MESSAGESIN AN
EMERGENCYMAINTENANCE
AND CARETECHNICAL
SPECIFICATIONSALPHABETICAL
INDEX

44

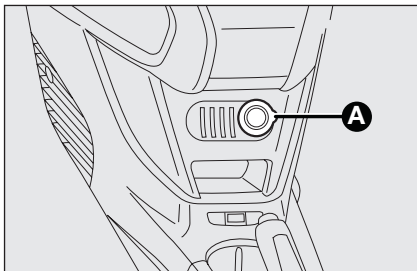

fig. 39

KA00032m

GLASS/BOTTLE HOLDER

Seats are present on the central tunnel for housing glasses and/or cans.

CURRENT OUTLET (where provided) fig. 39

Positioned on the central tunnel, the outlet is powered with ignition key on **MAR**.

To use the outlet, open the protective cover **A**.

Correct operation is ensured only if the connected devices are provided with homologated plugs, present on all the components of the Lineaccessori Ford.

IMPORTANT With engine off and key on **MAR**, the extended use (for instance for more than 1 hour) of accessories which drain much current may reduce battery efficiency, up to ignition failures.



Accessories with a maximum power of 180W (maximum electrical input 15A) can be connected to the outlet.

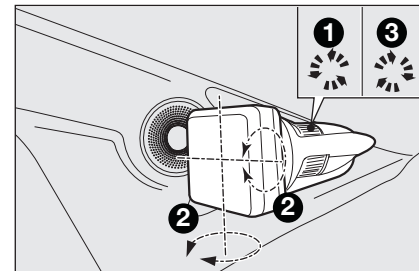
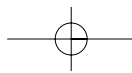

fig. 39a

KA00131m

INDIVIDUAL ADJUSTMENT OF THE COMMUNICATION CONSOLE fig. 39a (where provided)

Follow the procedure illustrated for the adjustment.



DOORS

LOCK/RELEASE FROM OUTSIDE

fig. 40

To open

Rotate the key to **1** and pull the handle upward.

With central control (where provided), on key rotation all door locks are released at the same time.

With remote control (where provided), press the button  to open the doors.

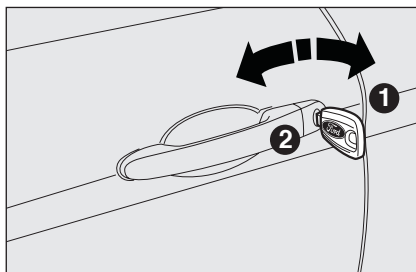

fig. 40

KA00033m

To lock

Rotate the key to **2** with fully closed door.

With central control (where provided), it is necessary that all doors are fully closed.

With remote control (where provided), press the button  to close the doors.

If one of the doors is not fully closed, simultaneous locking is disabled.

IMPORTANT If one of the doors is not properly closed or if there is a fault in the system, the central locking will not engage. After 10/11 manoeuvres in rapid succession, the device cuts out for 30 seconds.

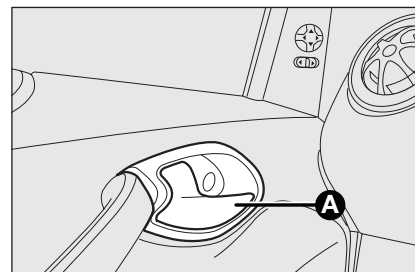

fig. 41

KA00034m

LOCK/RELEASE FROM INSIDE

fig. 41

To open

Pull the control lever **A**.

With central locking, operating the lever **A** on driver side releases all door locks.

For versions without central lockign, each door is released independently.



WARNING

Before opening a door, ensure that you can do it in safety conditions.

Open the doors only when the car is stationary.

YOUR CAR

SAFETY

STARTING AND DRIVING

WARNING LIGHTS AND MESSAGES

IN AN EMERGENCY

MAINTENANCE AND CARE

TECHNICAL SPECIFICATIONS

ALPHABETICAL INDEX

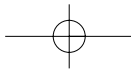

YOUR CAR

SAFETY

STARTING AND DRIVING

WARNING LIGHTS AND MESSAGES

IN AN EMERGENCY

MAINTENANCE AND CARE

TECHNICAL SPECIFICATIONS

ALPHABETICAL INDEX

To lock

With central locking push control lever **A** toward the door. Operating the lever **A** on driver side or the passenger side centrally locks the doors.

With a mechanic lock, without central locking, the doors are locked by operating the individual control levers on each door.

POWER WINDOWS

FRONT WINDOW WINDERS (where provided) fig. 42

They operate normally with ignition key on **MAR** and for about 3 minutes after positioning the key on **STOP** or removing.

The two buttons are located besides the gear lever (one for each side):

- A** to open/close the left front window;
- B** to open/close the right front window;

Holding the button pressed for a few seconds, the window automatically raises or lowers (only with key on **MAR**). On the passenger side button, the automatic device operates only to lower the glass.

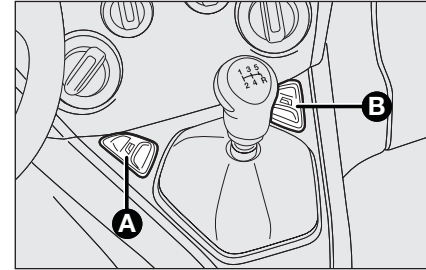

fig. 42

KA00035m



WARNING

When leaving the car, always remove the ignition key to avoid the risk of injury due to accidental operation of the power windows.



WARNING

Improper use of the electric windows may be dangerous.. Before operation, always check that no passenger is exposed to the risk of being injured directly by the moving window or by objects getting caught in or dragged by the window.

MANUAL WINDOW WINDERS

On some versions the window winders are manual.

To open/close, operate the handle.

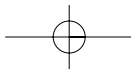

BOOT

TAILGATE OPENING

By means of mechanic key fig. 43

To release the lock, use the metal insert of the ignition key **A**.

Tailgate opening is eased by the action of the side gas shock absorbers.

Opening the tailgate, for some versions, the boot light turns on: the light automatically turns off after you close the tailgate.

The light remains on for about 15 minutes after rotating the key to **STOP**: if, during this period, a door or the tailgate is opened, the 15 minutes timing is reset.

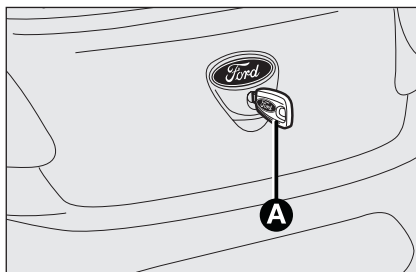

fig. 43

KA00036m

By means of key with remote control (where provided)

Press button  twice.

Tailgate opening is indicated by double flashing of direction indicators.

TAILGATE CLOSURE

To close, lower the tailgate pressing near the lock until you hear it click.



WARNING

Never exceed the maximum allowed load in the boot (see “Technical Specifications”). Make sure that the objects are well arranged in the boot so that they will not be projected forwards following sudden braking.

Do not travel with the tail-gate open: exhaust gas could enter the passenger compartment.



WARNING

If you travel in areas with few filling stations and you want to transport fuel in a spare tank, respect applicable laws, using only an homologated, suitably secured tank. However, the risks in case of collision increase.

Take care not to knock objects on the roof rack when opening the tailgate.

YOUR CAR

SAFETY

STARTING AND DRIVING

WARNING LIGHTS AND MESSAGES

IN AN EMERGENCY

MAINTENANCE AND CARE

TECHNICAL SPECIFICATIONS

ALPHABETICAL INDEX

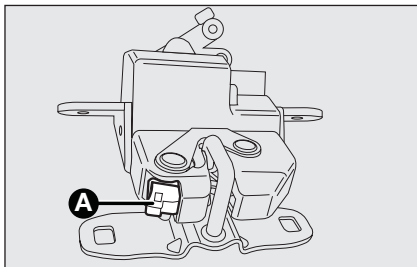
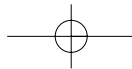

fig. 44

KA00037m

TAILGATE EMERGENCY OPENING fig. 44

To open the tailgate from the passenger's compartment if the car battery is flat or the electric tailgate lock is faulty, proceed as follows (see "Extending the boot" in this chapter):

- remove the rear head restraints;
- tilt the backrests;
- to achieve tailgate automatic unlock, from inside the boot, operate lever **A**.

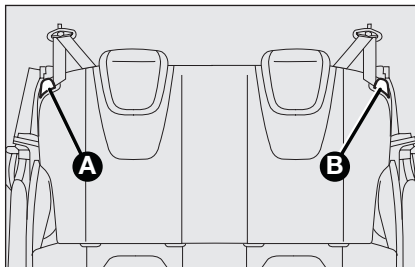

fig. 45

KA00019m

EXTENDING THE BOOT

Partial extension (50/50) (where provided) fig. 45

The separate rear seats allow partial or total boot extension.

Proceed as follows:

- Lift out rear seat head restraints (where provided) with backrest released and tilted toward the passenger compartment or with the tailgate open.
- check that the seat belt is not twisted;
- operate levers **A** or **B**-fig. 45 to release respectively the left or right part of the backrest and guide the backrest onto the cushion.

IMPORTANT To return the backrest to its correct position, we recommend to operate from the external doors.

Full extension

Tilt the rear seat completely to obtain maximum boot extension.

Proceed as follows:

- remove the rear seat head restraints (where provided);
- check that the seat belt is not twisted;
- operate levers **A** and **B**-fig. 45 to release the backrests and guide them onto the cushion.

IMPORTANT To return the backrest to its correct position, we recommend to operate from the external doors.

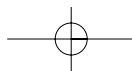

Rear seat repositioning

Raise the seat backrests and push them back until hearing the locking click of both retainers.

Position the seat belt buckles up.

IMPORTANT When returning the backrest to the position of use, make sure it is correctly fastened and you hear the lock click.

Make sure the backrest is properly secured at both sides to prevent it moving forward in the event of sharp braking causing injuries to passengers.

REMOVING THE REAR PARCEL SHELF

To remove the rear shelf, release it from its two side pins and pull it out.

BONNET

Opening fig. 46-47-48

Proceed as follows:

- pull lever **A** in the direction of the arrow;
- move to the right the lever **B** as shown in figure;
- lift the bonnet and at the same time release the support rod **C** from its locking device **D**, then insert the end of the rod in the seat **E** of the engine hood (bigger hole) and push to safety position (smaller hole), as shown in figure.



WARNING

If the supporting rod is not positioned correctly the bonnet may fall violently. Perform these operations when the car is stationary only.

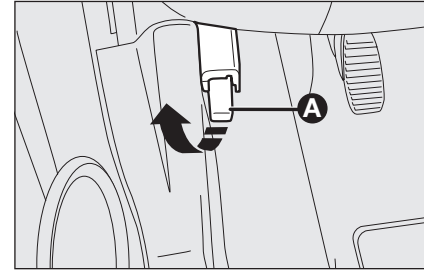

fig. 46

KA00038m

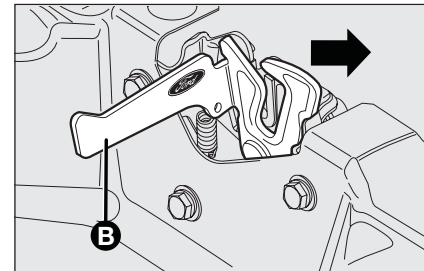

fig. 47

KA00039m

YOUR CAR

SAFETY

STARTING AND DRIVING

WARNING LIGHTS AND MESSAGES

IN AN EMERGENCY

MAINTENANCE AND CARE

TECHNICAL SPECIFICATIONS

ALPHABETICAL INDEX

**WARNING**

Before lifting the bonnet, ensure that the wiper arm is not lifted from the windscreen.

**WARNING**

With hot engine, operate with caution inside the engine compartment to avoid burns. Do not put your hands near the fan: it could start to operate even when the key is removed from the ignition. Wait for engine cooling.

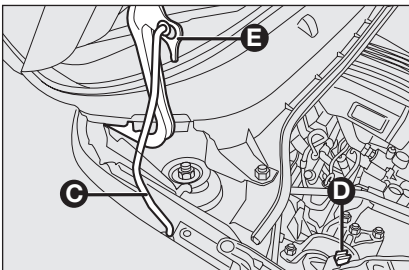

fig. 48

KA00114m

**WARNING**

Pay attention to scarves, ties and other loose fitting garments. If they accidentally touch moving parts, they may get dragged with serious risks for those who wear them.

To close fig. 48

Proceed as follows:

- hold the bonnet up with one hand and with the other remove rod **C** from seat **E** and fit it back into its catch **D**;
- lower the bonnet to approximately 20 centimetres from the engine compartment and let it drop. Make sure that the bonnet is completely closed and not only fastened by the safety catch by trying to open it. If it is not perfectly closed, open the bonnet and repeat the procedure. Do not simply press it.



WARNING

The bonnet must always be perfectly closed while travelling for safety reasons. Make sure that the bonnet is perfectly closed and that the lock is engaged. If you discover that the bonnet is not perfectly closed while travelling, stop immediately and close the bonnet in the correct manner.

HEADLIGHTS

BEAM DIRECTION

The correct orientation of the headlights is important for drivers comfort and safety. Besides, it is a specific rule of the highway code.

The headlights must be correctly directed to ensure the best visibility conditions for all drivers.

Contact a Ford Dealership to have the headlights properly adjusted.

Check beam aiming every time the load or its distribution changes.

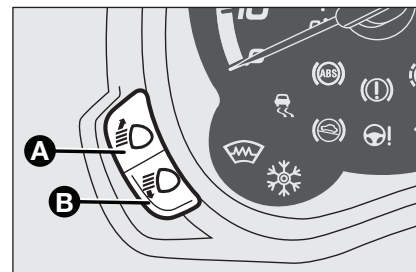

fig. 49

KA00040m

BEAM ADJUSTMENT fig. 49

The car is provided with electric adjustment of the beams, operating with ignition key on **MAR** and low beams on.

The car will angle backwards when it is loaded, raising the light beam.

In that case, it is necessary to perform beams adjustment with buttons **A** and **B**.

The display supplies a visual indication of positions.

YOUR CAR

SAFETY

STARTING AND DRIVING

WARNING LIGHTS AND MESSAGES

IN AN EMERGENCY

MAINTENANCE AND CARE

TECHNICAL SPECIFICATIONS

ALPHABETICAL INDEX

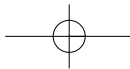

YOUR CAR

SAFETY

STARTING AND
DRIVINGWARNING
LIGHTS AND
MESSAGESIN AN
EMERGENCYMAINTENANCE
AND CARETECHNICAL
SPECIFICATIONSALPHABETICAL
INDEX

Correct positions depending on load

Position **0** - one or two passengers on front seats.

Position **1** - 5 passengers.

Position **2** - 4 passengers + load in the boot.

Position **3** - driver + maximum admitted load in the boot.

ADJUSTING HEADLIGHT BEAMS ABROAD

The low beam headlights are adjusted for the car to be driven in the country where it was purchased. When you travel in countries where cars are driven on the other side of the road, to avoid dazzling the drivers travelling in the opposite direction, it is necessary to cover certain areas of the headlight as laid down in the Highway Code of the country where you are driving.

AIMING THE FRONT FOG LIGHTS (where provided)

Contact a Ford Dealership to have the headlights properly adjusted.

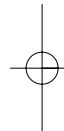
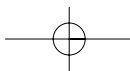

ABS SYSTEM

This system, an integral part of the braking system, which prevents the wheels from locking when braking, makes the most of road grip and gives the best control when emergency braking under difficult road conditions.

The system is completed by EBD (Electronic Braking Force Distribution), which distributes the braking action between front and rear wheels.

IMPORTANT To achieve maximum efficiency of the braking system, a settlement period of about 500 km is required: During this time, avoid sudden, repeated and prolonged braking.

ABS SYSTEM INTERVENTION

Intervention of the ABS is detected by a slight pulsing of the brake pedal accompanied by noise: such an event indicates that you need to adjust your speed to the type of road on which you are travelling.



WARNING

When the ABS cuts in, and you feel the brake pedal pulsating, do not remove your foot, but keep it pressed; in doing so you will stop in the shortest amount of space possible under the current road conditions.



WARNING

The ABS exploits the tyre-road grip at the best, but it cannot improve it; you should therefore take every care when driving on slippery surfaces without taking unnecessary risks.

FAILURE INDICATIONS

ABS failure

This is indicated by the turning on of warning light  on the instrument panel together with the dedicated message on the multifunctional display (where provided), (see section "Warning lights and messages").

In the case, the braking system will work as normal without the extra potentials offered by the ABS system. Drive carefully to the nearest Ford Dealership to have the system checked.

YOUR CAR

SAFETY

STARTING AND
DRIVINGWARNING
LIGHTS AND
MESSAGESIN AN
EMERGENCYMAINTENANCE
AND CARETECHNICAL
SPECIFICATIONSALPHABETICAL
INDEX

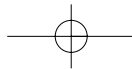



YOUR CAR

SAFETY

STARTING AND
DRIVINGWARNING
LIGHTS AND
MESSAGESIN AN
EMERGENCYMAINTENANCE
AND CARETECHNICAL
SPECIFICATIONSALPHABETICAL
INDEX

EBD failure

This is indicated by the turning on of warning lights  and  on the instrument panel together with the dedicated message on the multifunctional display (where provided), (see section “Warning lights and messages”).

In this case, the rear wheels may suddenly lock and the vehicle may swerve. Drive carefully to the nearest Ford Dealership to have the system checked.



WARNING

If warning light  only lights up on the instrument panel, (with a message on the multifunctional reconfigurable display, where provided), immediately stop the car and contact the nearest Ford Dealership. Leakage of hydraulic fluid from the braking system will compromise functionality of the braking system, either of the conventional type or with ABS.

ESP SYSTEM (Electronic Stability Program) (where provided)

The ESP system is an electronic system controlling the car stability in the event of tyre grip loss.

The ESP system is therefore particularly useful when grip conditions of the road surfaces change.

Besides the ESP, the car is provided with ASR (traction control with interventions on brakes and engines), HILL HOLDER (device for start on gradient without using the brakes), MSR (control of engine braking torque when shifting gear down) and HBA (automatic increase of braking pressure in case of emergency braking).

SYSTEM INTERVENTION

It is signalled by the blinking of the warning light  on the instrument panel, to inform the driver that the car is in critical stability and grip conditions.

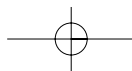

System intervention

The ESP system is automatically activated when the car is started and cannot be de-activated.

Failure indications

In the event of a failure, the ESP system will be automatically switched off and warning light  will appear on the instrument panel along with a message on the reconfigurable multifunctional display (where provided). The LED on the **ASR OFF** button will light up. Contact Ford Dealership.



WARNING

Do not take unnecessary risks, even if your car fits an ESP system. Your driving style must always be suited to the conditions of the road, visibility and traffic. The driver is always and only responsible for road safety.

HILL HOLDER SYSTEM (where provided)

It's integral to the ESP system. It automatically activates with the following conditions:

- uphill: car at a standstill on a road with a gradient higher than 2%, engine running, clutch and brake pedal pressed, gearbox to neutral or engaged gear other than reverse;
- downhill: car at a standstill on a road with a gradient higher than 2%, engine running, clutch and brake pedal pressed and reverse gear engaged.

At pickup the ESP system control unit will keep brake force on wheels until reaching the torque suitable for starting, or in any case for max. 2 seconds in order to pass easily from the brake pedal to the accelerator pedal.

After two seconds without starting, the system will deactivate automatically by releasing gradually the brake force. At releasing, the typical brake disengagement noise indicating that the car is going to move will be heard.

Failure indications

A system anomaly is indicated by the turning on of warning light  on the instrument panel together with the dedicated message on the multifunctional display (where provided), (see section "Warning lights and messages").



WARNING

The Hill Holder system is not a parking brake; therefore, never leave the car without having engaged the handbrake, turned the engine off and engaged the first speed.



WARNING

If the spare wheel is used, the ESP system keeps operating. The spare wheel, being smaller than the original wheel provides less grip.

For correct operation of the ESP and ASR systems, the tyres must absolutely be of the same brand and type on all wheels, in perfect conditions and, above all, of type, brand and size specified.

YOUR CAR

SAFETY

STARTING AND DRIVING

WARNING LIGHTS AND MESSAGES

IN AN EMERGENCY

MAINTENANCE AND CARE

TECHNICAL SPECIFICATIONS

ALPHABETICAL INDEX

ASR SYSTEM (Antislip Regulation) (where provided)

It's integral to the ESP system and automatically intervenes in case of slip of one or both drive wheels, helping the driver to control the car.

The action of the ASR is particularly helpful in the following circumstances:

- slipping of the inner wheel due to the effect of dynamic load changes or excessive acceleration;
- too much power transmitted to the wheels also in relation to the conditions of the road surface;
- acceleration on slippery, snowy or frozen surfaces;
- in the case of loss of grip on a wet surface.

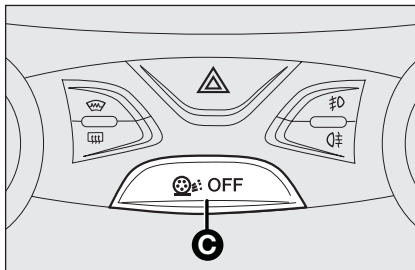

fig. 50

KA00041m

MSR system (engine braking torque control)

It is an integral part of the ASR system that in case of sudden gear downshifting, cuts in providing torque to the engine thus preventing excessive driving wheel drive that, specially in poor grip conditions, can lead to loss of stability.

Switching the ASR system on/off fig. 50

The ASR can work only when the ignition key is on MAR.

The ASR system can be turned off by pressing the button **C** ASR OFF.

When the system is active, a message on the reconfigurable multifunctional display (where provided) is displayed.

When the system is not active, the led on the button ASR OFF turns on and a message on the reconfigurable multifunctional display (where provided) is displayed. Turning off the ASR when travelling, on next start the ASR is automatically turned on by the system.

It may be useful to switch off the ASR when driving on snow-covered roads with snow chains fitted: in these conditions, slipping of the wheels during pick-up provides better traction.

EOBD SYSTEM

The EOBD system (European On Board Diagnosis) allows continuous diagnosis of the components of the car correlated with emissions. It also alerts the driver, by turning on the warning light  on the instrument panel (together with relevant message on the multifunction display, where provided), when these components are no longer in peak conditions (see section “Warning lights and messages”).

The objective is:



- to keep the system efficiency under control;
- to warn when a fault causes emissions levels to increase;
- to warn of the need to replace deteriorated components.

The system also has a diagnostic connector that can be interfaced with appropriate tools, which makes it possible to read the error codes stored in the control unit together with a series of specific parameters for engine operation and diagnosis.

This check can also be carried out by the traffic police.

IMPORTANT After eliminating the problem, to check the system completely, Ford Dealerships are obliged to run a bench test and, if necessary, road tests which may also call for a long journey.



Go to a Ford Dealership as soon as possible if the warning light  does not light up when the key is turned to MAR or if, during car travel, the warning light comes on either steady or blinking (along with a message on the display). The operation of the warning light  may be checked by the traffic police using specific devices. Follow the laws in force in the country where you are driving.

YOUR CAR

SAFETY

STARTING AND
DRIVINGWARNING
LIGHTS AND
MESSAGESIN AN
EMERGENCYMAINTENANCE
AND CARETECHNICAL
SPECIFICATIONSALPHABETICAL
INDEX

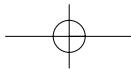

YOUR CAR

SAFETY

STARTING AND
DRIVINGWARNING
LIGHTS AND
MESSAGESIN AN
EMERGENCYMAINTENANCE
AND CARETECHNICAL
SPECIFICATIONSALPHABETICAL
INDEX

PARKING SENSORS (where provided)

Parking sensors are located in the rear bumper **fig. 51** and their function is to inform the driver, through an intermittent buzzer, about the presence of obstacles behind the car.

ACTIVATION

The sensors are automatically activated when the reverse gear is engaged. As the distance from the obstacle behind the car decreases, the acoustic alarm becomes more frequent.

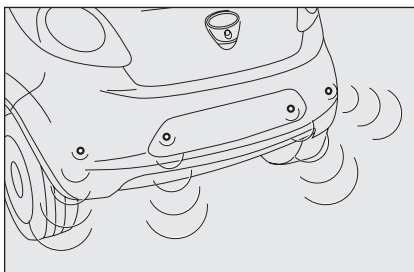

fig. 51

KA00042m

BUZZER WARNINGS

Engage reverse and if a rear obstacle is present, an acoustic signal is activated that changes as the distance between the obstacle and the bumpers changes.

The beep:

- becomes louder as the reduction of distance between the car and the obstacle decreases;
- becomes continuous when the distance between the car and the obstacle is less than 30 cm and stops immediately if the distance increases;
- is constant if the distance is unvaried; if this situation concerns the side sensors, the buzzer will stop after about 3 seconds to avoid, for example, warning indications in the event of manoeuvres along walls.

If several obstacles are detected, the control unit indicates the nearest one.

FAILURE INDICATIONS

Parking sensor failures, if any, will be indicated when engaging reverse by the turning on of the instrument panel warning light  together with the message on the multifunction display, where provided (see section "Warning lights and messages").

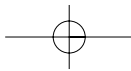

OPERATION WITH TRAILER

Parking sensor operation is deactivated automatically when the trailer electric cable plug is fitted into the car tow hook socket. Sensors are automatically enabled again when removing the trailer cable plug.



The sensor must be clean from mud, dirt, snow or ice in order for the system to work. Be careful not to scratch or damage the sensors while cleaning them. Avoid using dry, rough or hard cloths. Wash the sensors with clean water with the addition of car shampoo, if necessary. In washing stations, clean sensors quickly keeping the vapour jet/high pressure washing nozzles at 10 cm at least from the sensors.

GENERAL WARNINGS

- When parking, take the utmost care to obstacles that may be set above or under the sensors.
- Objects set close to the car, under certain circumstances are not detected and could therefore cause damages to the car or be damaged.

Some of the conditions that could affect the performance of the parking system are described below:

- Reduced sensor sensitivity and a reduction in the parking assistance system performance could be due to the presence on the surface of the sensor of: ice, snow, mud and many coats of paint
- The sensor detects a non-existent object (echo interference) caused by mechanical interference, e.g.: car washing, rain (extreme wind conditions), hail.
- Signals sent by the sensor may be altered by the presence in the vicinity of ultrasound system (e.g. the air brakes of trucks or air hammers).
- The performance of the parking assistance system could be affected by the position of the sensors, e.g. by altering attitude (due to wear of shock absorbers and suspension) or by changing tyres, overloading the car or setting special attitudes that require the car to be lowered.



WARNING

The driver is always responsible for parking and other dangerous manoeuvres under all circumstances. Make sure that no-one is standing in the area, especially children or animals. Parking sensors are designed to assist drivers: in all cases, you must always pay the utmost attention during potentially dangerous manoeuvres, even when carried out at low speed.



WARNING

When repainting the bumpers or touching up paint in the sensor area, contact Ford Authorised Services. Incorrect paint application could affect the operation of the parking sensors.

YOUR CAR

SAFETY

STARTING AND
DRIVINGWARNING
LIGHTS AND
MESSAGESIN AN
EMERGENCYMAINTENANCE
AND CARETECHNICAL
SPECIFICATIONSALPHABETICAL
INDEX

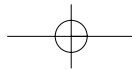

YOUR CAR

SAFETY

STARTING AND
DRIVINGWARNING
LIGHTS AND
MESSAGESIN AN
EMERGENCYMAINTENANCE
AND CARETECHNICAL
SPECIFICATIONSALPHABETICAL
INDEX

SOUND SYSTEM (where provided)

For the operation of the radio with CD/MP3 player (where provided), read the instructions for use given in the supplement attached to the Owner Handbook.



If a car radio is installed after car purchase, refer to the Ford Dealership for tips to safeguard battery durability. Excessive loadless absorption damages the battery and may void the battery warranty.

WIRING SYSTEM (where provided)

The radio wiring system consists of:

- radio supply leads;
- front speaker power leads;
- aerial lead;
- radio housing;
- aerial on car roof.

CAR RADIO (where provided)

Speakers for Basic Audio specification

Front speakers

N° 2 tweeters dia. 38 mm;

N° 2 mid-woofer speakers with dia 165 mm.

Rear speakers

N° 2 full-range speakers with dia 130 mm.

Speakers for Hi Fi Audio specification (if fitted)

Front speakers

N° 2 tweeters dia. 38 mm;

N° 2 mid-woofer speakers with dia 165 mm.

Rear speakers

N° 2 full-range speakers with dia 130 mm.

N° 1 amplifier.

N° 1 bass box.

AUX-IN SOCKET (where fitted)

This is located on the central console for connection of an external source (e.g. MP3).

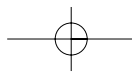

ACCESSORIES PURCHASED BY THE OWNER

If after buying the car, you decide to install electrical accessories that require a permanent electric supply (alarm, satellite antitheft system, etc.) or accessories that in any case burden the electric supply, contact Ford Dealership, whose qualified personnel, besides suggesting the most suitable devices belonging to Lineaccessori Ford, will also evaluate the overall electric absorption, checking whether the car's electric system is able to withstand the load required, or whether it needs to be integrated with a more powerful battery.

ELECTRICAL/ELECTRONIC DEVICE INSTALLATION

Electrical and electronic devices installed after buying the vehicle by after-market service must carry the following label:



Ford Auto S.p.A. authorises the installation of transceiving devices provided that they are installed according to rules of good engineering practice respecting the manufacturer's indications by a specialised centre.

IMPORTANT Traffic police may not allow the car on the road in the event of assembly of devices which imply modifications to the features of the car. This may also cause lapse of warranty in relation to faults caused by the change or either directly or indirectly related to it.

Ford Auto S.p.A. shall not be liable for damage caused by the installation of accessories either not supplied or recommended by Ford Auto S.p.A. and/or installed in compliance with the provided instructions.

RADIO TRANSMITTERS AND CELLULAR PHONES

Radio transceiver equipment (e.g.: e-tacs mobile phones, HAM radio systems and the like) shall not be used inside the car unless a separate aerial is mounted on the roof.

IMPORTANT The use of similar devices inside the passenger compartment (without an external aerial) produces radio-frequency electromagnetic fields which, amplified by the resonance effects inside the passenger compartment, may cause electrical systems equipping the car to malfunction. This could compromise safety in addition to constituting a potential hazard for the passengers.

In addition, transmission and reception of these devices may be affected by the shielding effect of the car body.

As concerns EC-approved mobile phones (GSM, GPRS, UMTS), strictly comply with the instructions for use provided by the mobile phone's manufacturer.

YOUR CAR

SAFETY

STARTING AND
DRIVINGWARNING
LIGHTS AND
MESSAGESIN AN
EMERGENCYMAINTENANCE
AND CARETECHNICAL
SPECIFICATIONSALPHABETICAL
INDEX

AT THE FILLING STATION

PETROL ENGINES

Use unleaded petrol only, with octane number (R.O.N.) not lower than 95.

IMPORTANT An inefficient catalyst leads to harmful exhaust emissions, thus contributing to air pollution.

IMPORTANT Never use leaded petrol, even in small amount or in an emergency, as this would damage the catalyst beyond repair.

DIESEL ENGINES

Operation at low temperatures

If the outside temperature is very low, the diesel thickens due to the formation of paraffin clots with consequent anomalous operation of the fuel supply system.

In order to avoid these problems, different types of diesel are distributed according to the season: summer type, winter type and arctic type (cold, mountain areas).

When using or parking the vehicle for a long time in the mountains or cold areas, it is advisable to refuel using locally available fuel.

In this case, it is also advisable to keep the tank over 50% full.



For diesel engines, use diesel fuel for motor vehicles compliant with EN590 European specifications only. The use of other products or mixtures may damage the engine beyond repair and consequently cause lapse of warranty in relation to the damage caused. If you accidentally introduce other types of fuel in the tank, do not start the engine and empty the tank. If the engine has run also for a very short time, you will need to have the entire fuel feed system emptied in addition to the tank.

REFUELLING CAPACITY

To fill the tank completely, top-up twice after the pump switches off. Further top-ups could cause faults in the fuel feeding system.

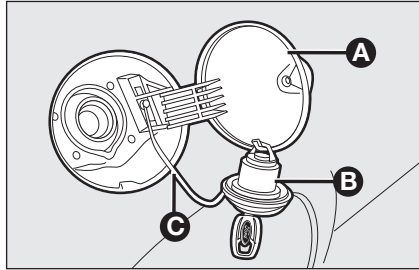

fig. 52

KA00043m

FUEL FILLER CAP fig. 52

The cap **B** is provided with a loss prevention device **C** which secures it to the lid **A**.

Unscrew cap **B** using the ignition key. The airtight closing may determine a slight increase of pressure in the tank. A suction noise when you release the cap is therefore entirely normal. When refuelling, fasten the plug to the device inside the lid as shown in the figure.



Do not place naked flames or lit cigarettes near to the fuel filler: fire risk. Keep your face away from the fuel filler to prevent breathing in harmful vapours.

PROTECTING THE ENVIRONMENT

The devices for curtailing petrol engine emissions are the following:

- three-way catalytic converter;
- Lambda sensors;
- fuel evaporation prevention system.

In addition, do not let the engine run, even for a test, with one or more spark plugs disconnected.

The devices for curtailing diesel fuel engine emissions are the following:

- oxidising catalytic converter;
- exhaust gas recirculation system (E.G.R.).
- diesel particulate filter (DPF)



WARNING

The catalytic converter develops high temperature during operation. Do not park on grass, dry leaves, pine needles or other flammable material: fire risk.

YOUR CAR

SAFETY

STARTING AND
DRIVINGWARNING
LIGHTS AND
MESSAGESIN AN
EMERGENCYMAINTENANCE
AND CARETECHNICAL
SPECIFICATIONSALPHABETICAL
INDEX

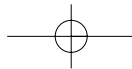

YOUR CAR

SAFETY

STARTING AND
DRIVINGWARNING
LIGHTS AND
MESSAGESIN AN
EMERGENCYMAINTENANCE
AND CARETECHNICAL
SPECIFICATIONSALPHABETICAL
INDEX

DIESEL PARTICULATE FILTER (DPF) I.3L Duratorq

The Diesel Particulate Filter is a mechanical filter, integral with the exhaust system, that physically traps particulates present in the exhaust gases of Diesel engines. The diesel particulate filter has been adopted to eliminate almost totally particulates in compliance with current / future law regulations. During normal use of the car, the engine control unit records a set of data (e.g.: travel time, type of route, temperatures, etc.) and it will then calculate the amount of particulates trapped by the filter. Since this filter physically traps particulates, it shall be cleaned (reclaimed) at regular intervals by burning carbon particles. The regeneration procedure is controlled automatically by the engine control unit according to the filter conditions and the conditions of use of the car. During the regeneration procedure, the following situations may occur: limited increase of idle speed, activation of electric fan, limited increase of smoke,

high temperatures at the exhaust. These are not anomalies; they do impair car behaviour and the environment. If the dedicated message is displayed, refer to section “Warning lights and messages”.

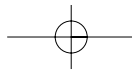
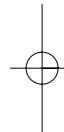

SAFETY

SEAT BELTS	66
S.B.R. SYSTEM	66
PRETENSIONERS	67
CARRYING CHILDREN SAFELY	69
FITTING UNIVERSAL CHILD SEAT	70
ASSEMBLY SETUP ISOFIX CHILD SEAT	73
FRONT AIRBAGS.....	75
WINDOW BAGS	77

YOUR CAR

SAFETY

STARTING AND
DRIVING

WARNING
LIGHTS AND
MESSAGES

IN AN
EMERGENCY

MAINTENANCE
AND CARE

TECHNICAL
SPECIFICATIONS

ALPHABETICAL
INDEX

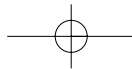

SEAT BELTS

USING THE SEAT BELTS fig. 1

Wear the belt keeping the chest straight and rested against the backrest.

To fasten the seat belts, hold the tongue **A** and insert it into the buckle **B**, until hearing the locking click. At removal, if it jams, let it rewind for a short stretch, then pull it out again without jerking.

Press button **C** to release the belt. Accompany the belt while it is being rewound to prevent twisting. Through the reel, the belt automatically adapts to the body of the passenger wearing it, allowing freedom of movement.



WARNING

Never press button **C** when travelling.

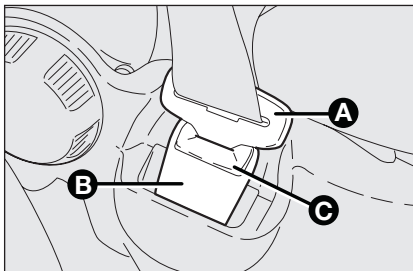

fig. 1

KA00044m

The reel may lock when the car is parked on a steep slope: this is perfectly normal. In addition, the reel mechanism blocks the belt whenever it is pulled and in the event of brisk braking, collisions and on high speed bends.

The rear seat is fitted with inertial seat belts with three anchor points and reel.





WARNING

Remember that in the event of a violent collision, rear seat passengers that do not wear the seat belt both pose a risk for their safety and represent a serious danger for the front seat passengers.

S.B.R. SYSTEM

The car is provided with the S.B.R. (Seat Belt Reminder) system, which warns the driver and the front passenger if the seat belt is not buckled, as follows:

- warning light  turns on steady and continuous activation of the beeper for the first 6 seconds;
- warning light  blinks and intermittent activation of the beeper for the next 90 seconds;

Contact a Ford Dealership to deactivate/reactivate the SBR system.

È the S.B.R. system can be reactivated via the display set-up menu if the vehicle is equipped with a multifunction display.

The display will show the dedicated message.

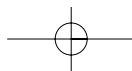

PRETENSIONERS

To increase the efficiency of the seat belts, the car is fitted with front pretensioners. These devices, in the event of a violent crash, rewind the seat belts a few centimetres. In this way they ensure that the seat belt adheres perfectly to the wearer before the restraining action begins. The seat belt locks to indicate that the device has intervened; the seat belt cannot be drawn back up even when guiding it manually.

This car is provided with a second pretensioner (in the sill board area). Its activation is signalled by the shortening of the metallic cable.

IMPORTANT To obtain the highest degree of protection from the action of the pretensioning device, wear the seat belt keeping it firmly close to the chest and pelvis.

A small amount of smoke may be produced. This smoke is in no way toxic and presents no fire hazard. The pretensioner does not require any maintenance or greasing. Anything that modifies its original conditions invalidates its efficiency. If due to unusual natural events (floods, sea storms, etc.) the device has been affected by water and mud, it must necessarily be replaced.



WARNING

The pretensioner can only be used once. Go to a Ford Dealership to have it replaced after it has been deployed.



Operations which lead to shocks, vibrations or localised heating (over 100°C for a maximum of 6 hours) in the area around the pretensioners may damage or trigger them. These devices are not affected by vibrations caused by irregularities of the road surface or low obstacles such as kerbs, etc. Contact Ford Dealership for any assistance.

LOAD LIMITERS

To increase passenger's safety, the reels contain a load limiter which allows controlled sag in such a way as to dose the force acting on the chest and shoulders during the belt restraining action in case of front crash.

GENERAL INSTRUCTIONS FOR USING THE SEAT BELTS

The driver is responsible for respecting and ensuring that all the other occupants of the car also respect the local laws in force in relation to the use of seat belts. Always fasten the seat belts before starting off.

Seat belts must also be used by pregnant women: risk will be significantly reduced for both the expectant mother and the child in the event of an accident. Pregnant women must position the lower part of the belt very low down so that it passes over the pelvis and under the abdomen (as indicated in **fig. 2**).

YOUR CAR

SAFETY

STARTING AND DRIVING

WARNING LIGHTS AND MESSAGES

IN AN EMERGENCY

MAINTENANCE AND CARE

TECHNICAL SPECIFICATIONS

ALPHABETICAL INDEX

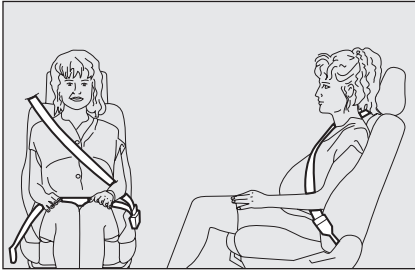
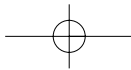

fig. 2

KA00045m

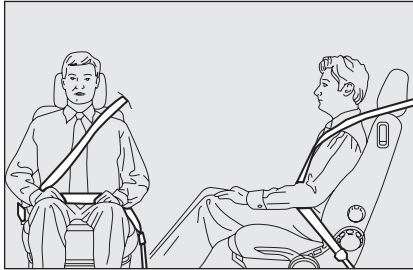

fig. 3

KA00046m

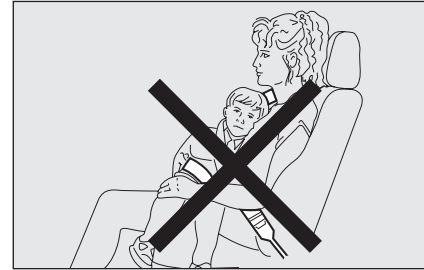

fig. 4

KA00047m

**WARNING**

For maximum safety, keep the back of your seat upright, lean back into it and make sure the seat belt fits closely across your chest and hips. Always fasten the seat belts on both the front and the rear seats. Travelling without seat belts will increase the risk of severe injury and even death in the event of an accident.

Never disassemble or tamper with the seat belt or pretensioner components. All interventions must be performed by qualified and authorised personnel only. Always go to a Ford Dealership.

IMPORTANT The belt must not be twisted. The upper part must cross the shoulder and the chest diagonally. The lower part must fit the hips (as shown in **fig. 3**) rather than the abdomen of the passenger. Do not use devices (clips, etc.) to hold the seat belt away from your body.

IMPORTANT Each seat belt may only be used by a single person: do not carry children on your lap with one seat belt protecting both **fig. 4**. In general, do not place any objects between the passenger and the belt.

**WARNING**

If the belt has been subjected to heavy stress, for example after an accident, it should be changed completely together with the anchors, anchor fastening screws and the pretensioners. In fact, even if the belt has no visible defects, it could have lost its resilience.

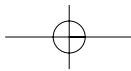

SEAT BELTS MAINTENANCE

Observe the following:

- always use the belt with the tap well stretched and never twisted; make sure that it is free to run without impediments;
- replace the belt after an accident of a certain severity even if it does not appear damaged. Always replace the belt if the pretensioners were deployed.
- To clean the belt, wash by hand with water and mild soap, rinse and leave to dry in the shade. Do not use strong detergents, bleach, paints or any other substance which could damage the belt fibres.
- Keep the reels dry: correct operation may only be ensured if they are not affected by leaks;
- Replace the seat belt when showing significant wear or cut signs.

CARRYING CHILDREN SAFELY

For optimal protection in the event of a crash, all passengers must be seated and wear adequate restraint systems.

This is even more important for children.

This prescription is compulsory in all EC countries according to ECE-R44.03.

A child's head is larger and heavier in proportion to his/her body and the child's muscular and bone structures are not fully developed.

For this reason, they require restraint systems which are different from those used by adults to protect them in the event of an accident.

The research results in relation to the best protection for children is illustrated in European Regulation ECE-R44 which divides the restraint systems into five groups in addition to making their use compulsory:

- Group 0 - up to 10 kg in weight
- Group 0+ - up to 13 kg in weight
- Group 1 9-18 kg in weight
- Group 2 15-25 kg in weight
- Group 3 22 - 36 kg in weight



WARNING



SEVERE DANGER: Do not arrange child seats facing backwards on the front seat if the passenger's airbag is on. Deployment of the airbag in an accident could cause fatal injuries to the baby. It is advisable to carry children on the rear seat, which is the most protected position in the event of an accident. Child seats must not be fitted on the front seat of cars provided with passenger air bag, whose deployment in an accident could cause fatal injuries to the baby irrespective of the severity of the impact that caused the activation. If necessary, children can stay on the front seat, if the passenger's airbag can be disabled. Verify that the airbag is actually deactivated, observing the warning light  on the dashboard (see "Front airbag - passenger side" at paragraph "Front airbags"). Move the passenger's seat as far back as possible to avoid contact between the child seat and the dashboard.

YOUR CAR

SAFETY

STARTING AND
DRIVINGWARNING
LIGHTS AND
MESSAGESIN AN
EMERGENCYMAINTENANCE
AND CARETECHNICAL
SPECIFICATIONSALPHABETICAL
INDEX

All restraint devices must bear the type-approval data along with the control mark on a label that must be firmly secured to the child seat and must never be removed.

Over 1.50 m in height, from the point of view of restraint systems, children are considered as adults and have to wear the standard seat belts. Lineaccessori Ford includes child seats for each weight group.

These devices are recommended having been specifically designed for Ford cars.

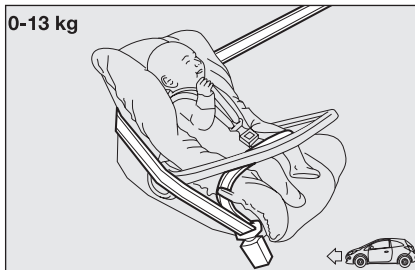

fig. 5

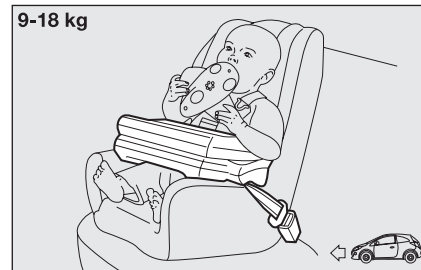

fig. 6

UNIVERSAL CHILD'S SEAT INSTALLATION (WITH SEAT BELTS)

GROUP 0 and 0+

Babies up to 13 kg must be carried facing backwards on a cradle seat, which, supporting the head, does not induce stress on the neck in the event of sharp deceleration.

The cradle is restrained by the car seat belts, as shown in **fig. 5** and in turn it must restrain the child with its own belts.

GROUP I

From 9 to 18kg of weight, children may be carried facing forward. Some types of seat are equipped with a front cushion that enables the car seat belt to restrain both child and seat **fig. 6**.



WARNING

The figures are indicative for assembly purposes only. Refer to the instructions supplied with the child seat.

Some child restraint systems for weight group 0 and I have a rear attachment and seat belts for securing the child. Due to their weight, they may be dangerous if incorrectly mounted (e.g. if fastened to the car seat belts with a cushion in between). Follow the assembly instructions carefully.



fig. 7

KA00050m

GROUP 2

Children from 15 to 25 kg may use the car seat belts directly **fig. 7**.

The child seat is only needed to position the child correctly with respect to the belts so that the diagonal section crosses the child's chest and never the neck and is snug on the hips not the abdomen.

**WARNING**

The figures are indicative for assembly purposes only. Refer to the instructions supplied with the child seat.



fig. 8

KA00051m

GROUP 3

For children from 22 kg to 36 kg the size of the child's chest no longer requires a support to space the child's back from the seat back.

Fig. 8 shows proper child seat positioning on the rear seat.

Children over 1.50 m in height can wear seat belts like adults.

**WARNING**

The figures are indicative for assembly purposes only. Refer to the instructions supplied with the child seat.

YOUR CAR

SAFETY

STARTING AND
DRIVINGWARNING
LIGHTS AND
MESSAGESIN AN
EMERGENCYMAINTENANCE
AND CARETECHNICAL
SPECIFICATIONSALPHABETICAL
INDEX

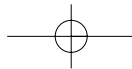

YOUR CAR

SAFETY

STARTING AND DRIVING

WARNING LIGHTS AND MESSAGES

IN AN EMERGENCY

MAINTENANCE AND CARE

TECHNICAL SPECIFICATIONS

ALPHABETICAL INDEX

PASSENGER SEAT COMPLIANCE WITH REGULATIONS ON UNIVERSAL CHILD SEAT USE

The Ford  complies with the new European Directive 2003/20/EC which governs the arrangement possibilities for child restraints on the various seats of the car as shown in the following table:

Group	Weight ranges	Passenger front	Passenger rear
Group 0, 0+	up to 13 kg	U	U
Group 1	9-18 kg	U	U
Group 2	15-25 kg	U	U
Group 3	22-36 kg	U	U

Key:

U = suitable for child restraint systems of the “Universal” category, according to European standard ECE-R44 for the specified “Groups”.

Below is a summary of the safety rules to be followed for carrying children.

- Install the child seats on the rear seat, which is the most protected position in the event of an accident.
- If the passenger's air bag is deactivated, always check the amber warning light  on the instrument panel to make sure that it has actually been deactivated.
- Carefully follow the instructions supplied with the child restraint system which are mandatory by law. Keep the instructions in the car along with the other papers and this handbook. Do not use child seats without instructions.
- Always check the seat belt is well fastened by pulling the belt.

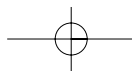

- Only one child is to be strapped to each retaining system.
- Always check the seat belts do not fit around the child's throat.
- While travelling, do not let the child sit incorrectly or release the belts.
- Never carry children on your lap, even newborns. No-one can hold a child in the case of an accident.
- In case of an accident, replace the child's seat with a new one.



WARNING

Do not arrange child seats on the front seat in vehicles fitted with a passenger's airbag. Children must never travel on the front seat.

ISOFIX CHILD RESTRAINT ASSEMBLY SETUP

Provision has been made on the car to mount a Universal Isofix child restraint system, a new European standardised system for carrying children safely.

Isofix systems can be mounted simultaneously with a traditional restraint system. An example of child seat is shown in **fig. 9**. The Universal Isofix child seat covers weight group: 1. The other weight groups are covered by the specific Isofix child seat, which can be used only if specifically designed, tested and homologated for this car (see car list provided with the child seat).

Due to its different anchoring system, the child's seat shall be anchored to the proper lower metal rings **A-fig. 10**, set between rear seat back and cushion. After removing the rear shelf, secure the upper belt (provided with the child's seat) to ring **B-fig. 11** set between the rear backrest and the boot floor. Do not use ring **B** for fixing other object

Remember that in case of Universal Isofix child's seat, you can only use all those seats approved with the marking ECE R44/03 "Universal Isofix".

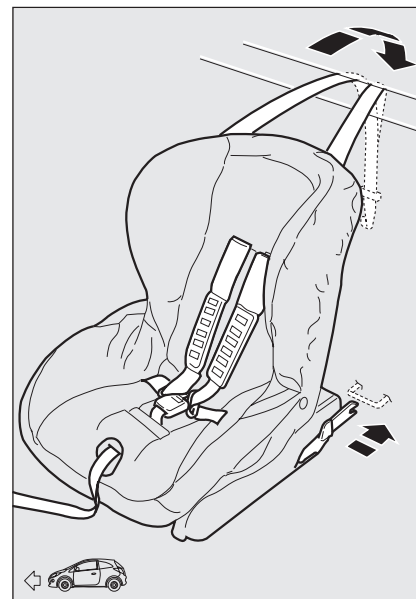

fig. 9

KA00052m

The Lineaccessori Ford includes the Universal Isofix "Duo Plus" child seat.

For any further installation/use detail, refer to the "Instructions Manual" of the child seat.

YOUR CAR

SAFETY

STARTING AND DRIVING

WARNING LIGHTS AND MESSAGES

IN AN EMERGENCY

MAINTENANCE AND CARE

TECHNICAL SPECIFICATIONS

ALPHABETICAL INDEX

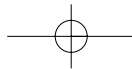

YOUR CAR

SAFETY

STARTING AND DRIVING

WARNING LIGHTS AND MESSAGES

IN AN EMERGENCY

MAINTENANCE AND CARE

TECHNICAL SPECIFICATIONS

ALPHABETICAL INDEX

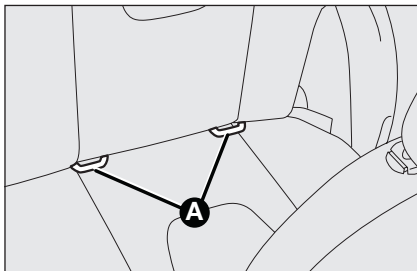

fig. 10

KA00053m

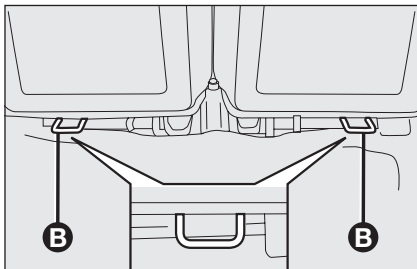

fig. 11

KA00054m

**WARNING**

Fit the child seat when the car is stationary. The child seat is correctly anchored to the brackets when you hear the click. Follow the instructions for assembly, disassembly and positioning that the manufacturer must supply with the child seat.

PASSENGER SEAT COMPLIANCE WITH REGULATIONS ON UNIVERSAL ISOFIX CHILD'S SEAT USE

The table below shows the different installation possibilities of Isofix restraint systems on seats fitted with Universal Isofix fasteners in compliance with European standard ECE 16.

Weight group	Orientation child seat	Class Isofix size	Isofix position rear side
Group 0 - 0 to 10 kg	Facing backwards	E	X
	Facing backwards	E	X
Group 0+ up to 13 kg	Facing backwards	D	X
	Facing backwards	C	X
	Facing backwards	D	X
	Facing backwards	C	X
Group I from 9 up to 18 kg	Facing forwards	B	IUF
	Facing forwards	BI	IUF
	Facing forwards	A	X

IUF: suitable for Isofix child restraint systems to be set facing forwards, universal class (fitted with third upper fastener), approved for the relevant weight group.

IL: suitable for special child restraint systems, specific Isofix type, and type-approved for this type of car. The seat can be installed by moving the front seat forward.

X: Isofix position not suited for Isofix child restraint systems in this weight group and/or in this size class.

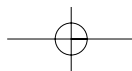

AIRBAGS

The vehicle is equipped with front airbags for driver and passenger and front side air bags (side bag - window bag) (where specified).

FRONT AIRBAGS

The front airbags (for driver and passenger) have been designed to protect the passengers sitting on the front seats in the event of head-on crashes of medium-high severity, by placing the bag between the person and the steering wheel or dashboard.

Front air bags are designed to protect car's occupants in front crashes and therefore non-activation in other types of collisions (side collisions, rear shunts, roll-overs, etc.) is not a system malfunction.

An electronic control unit causes the bag to inflate in the event of a front crash.

The bag will inflate instantaneously placing itself between the front occupant's body and the structures which could cause injury. It will deflate immediately afterwards.

Driver and passenger front airbags are not a replacement of, but complementary to the seat belts, which you must always wear, as specified by law in Europe and most non-European countries.

In the event of a collision, a person not wearing the seat belt may be thrown forward and come into contact with the bag before it has fully opened. The protection offered by the cushion is reduced in such a case.

Front airbags may not be activated in the following situations:

- in collisions against highly deformable objects not affecting the car front surface (e.g. bumper collision against guard rail, etc.);
- car penetration under other vehicles or protective barriers (e.g. trucks or guard rails);

they could not provide any additional protection compared with seat belts, so their deployment would be improper. No deployment in such cases is consequently not the sign of a fault.



WARNING

Do not apply stickers or other objects on the steering wheel, on the dashboard in the passenger side airbag area, on side upholstery on roof and on the seats. Do not place objects (e.g. cell phones) on the passenger side dashboard because these could interfere with the correct opening of the airbag and cause severe injury to occupants.

The front airbags on the driver's and passenger's sides are designed and calibrated to protect the front seat passengers who wear the safety belts.

The volume of the front airbags at max. inflation fills most of the space between the steering wheel and the driver and between the dashboard and the passenger.

The airbags are not deployed in the event of front collisions of low severity (for which the withholding action of the seat belts is sufficient).

Safety belts must always be used. In the event of frontal crash they ensure the correct positioning of the occupant.

YOUR CAR

SAFETY

STARTING AND
DRIVINGWARNING
LIGHTS AND
MESSAGESIN AN
EMERGENCYMAINTENANCE
AND CARETECHNICAL
SPECIFICATIONSALPHABETICAL
INDEX

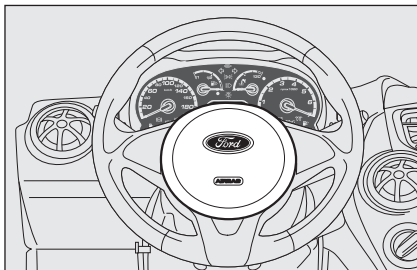

fig. 12

KA00055m

FRONT AIRBAG ON DRIVER'S SIDE, fig. 12

It consists of an instant-inflating bag contained in a special recess in the centre of the steering wheel.

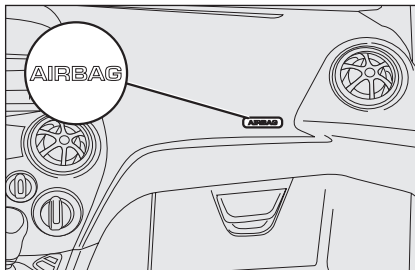

fig. 13

KA00056m

FRONT AIRBAG ON PASSENGER'S SIDE, fig. 13

It consists of an instant-inflating bag contained into a special recess in the dashboard: this bag has a bigger volume than that of the driver.



WARNING



SEVERE DANGER: Do not arrange child seats facing backwards if the passenger's front airbag is on. Deployment of the airbag in an accident could cause fatal injuries to the baby. Always deactivate the passenger's airbag when placing a child seat on the front seat. Move the passenger's seat as far back as possible to avoid contact between the child seat and the dashboard. Although this is not mandatory by law, the airbag should be immediately reactivated when children are no longer carried to ensure better protection to adults.

MANUAL DEACTIVATION OF PASSENGER'S FRONT AIR BAG AND SIDE BAG (where provided)

Whenever a child needs to be carried on the front seat, the passenger's front airbag and the Side Bag (where provided) must be deactivated. This function may be activated only by taking car to dealership.

The instrument panel warning light  will stay on glowing steadily until reactivating the passenger's front air bag and the Side Bag (where provided).

WARNING To deactivate the passenger's front air bag and the Side Bag (where provided), refer to paragraphs "Digital display" and "Multifunctional display" in section "Your car".

SIDE BAGS - WINDOW BAGS) (where provided)

SIDE BAG fig. 14

It consists of an instant-inflating bag housed in the front seat backrest. It protects the chest and the hips of the passengers in the event of side crashes of medium-high severity.

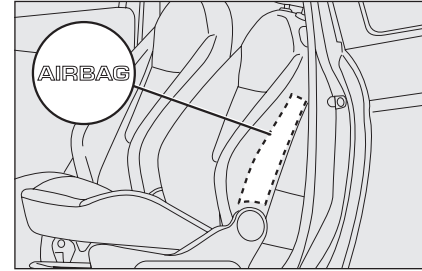

fig. 14

KA00057m

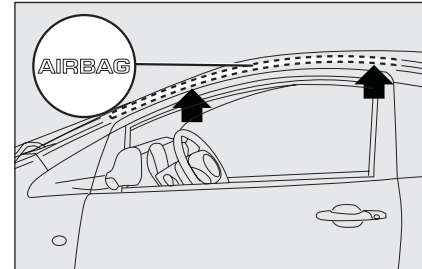

fig. 15

KA00058m

WINDOW BAGS fig. 15

They consist of two "curtain" cushions housed behind the side upholstery of the roof and covered by specific finishing to protect the head of the front passengers in the event of side crash, thanks to their wide surface.

YOUR CAR

SAFETY

STARTING AND
DRIVINGWARNING
LIGHTS AND
MESSAGESIN AN
EMERGENCYMAINTENANCE
AND CARETECHNICAL
SPECIFICATIONSALPHABETICAL
INDEX

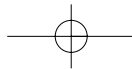

YOUR CAR

SAFETY

STARTING AND
DRIVINGWARNING
LIGHTS AND
MESSAGESIN AN
EMERGENCYMAINTENANCE
AND CARETECHNICAL
SPECIFICATIONSALPHABETICAL
INDEX

IMPORTANT The best protection in the event of side crash is achieved maintaining a correct position on the seat. This allows the correct deployment of the window bag.

IMPORTANT The front air bags and/or side bags may be deployed also if the car is subject to heavy knocks or accidents involving the underbody area, such as violent shocks against steps, kerbs or low obstacles, falling of the car in big holes or sags in the road.

IMPORTANT A small amount of dust will be released when the airbags are deployed. The dust is not harmful and does not indicate the beginning of a fire. Furthermore, the surface of the deployed bag and the interior of the car may be covered in a dusty residue: This dust may irritate the skin and the eyes. Wash with mild soap and water in the event of exposure.

IMPORTANT If any safety device has activated due to an accident, refer to the Ford Dealership to replace them and check system integrity.

Airbag checking, repair and replacement must only be carried out c/o the Ford Dealership. If you are having the car scrapped, have the airbag system deactivated at a dealership first. If the car changes ownership, the new owner must be informed of how to use the airbags and the above warnings: s/he must also be given this "Owner's Handbook".

IMPORTANT Pretensioners, front airbags and side bags are deployed according to different logics on the basis of the type of collision. Non-deployment of one of the devices does not necessarily indicate a system malfunction.

**WARNING**

Do not rest the head, the arms or the elbows on the door, on the windows and on the window bag area to avoid injuries during inflation.

Never lean head, arms and elbows out of window.

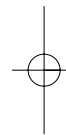
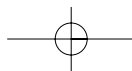

GENERAL WARNINGS



WARNING

If when turning the key to MAR the warning light  does not turn on or stays on during car travel (together with the message on the multifunctional display, where provided), a failure may have occurred in the restraint systems. In this case the airbags or pretensioners may not be deployed after an impact or, in a minor number of cases, they may be deployed accidentally. Contact Ford Dealership immediately to have the system checked before driving off.



WARNING

Do not cover the front seat backrest with covers if a Side-bag is fitted.



WARNING

Do not travel with objects in your lap, in front of your chest, or keeping between your lips pipes, pencils, etc.. In the event of crash with airbag activation, you may be seriously injured.



WARNING

Always drive keeping your hands on the steering wheel crown so that, in the event of airbag activation, it can inflate without finding obstacles. Do not drive with your body bent forward. Keep the backrest in straight position, resting correctly your back on it.



WARNING

It someone tried to steal or damage your car, and in the event of floods, have the air bag system checked by the Ford Dealership.



WARNING

With ignition key inserted, on MAR, even if the engine is off, the air bags can activate also with the car stopped, if it is hit by another vehicle. For this reason, children must never sit on the front seat, even if the car is not moving. We remind you that if the key is inserted on STOP, no safety device (air bag or pretensioner) activates following a collision; no deployment in such cases is consequently not the sign of a fault.

YOUR CAR

SAFETY

STARTING AND
DRIVINGWARNING
LIGHTS AND
MESSAGESIN AN
EMERGENCYMAINTENANCE
AND CARETECHNICAL
SPECIFICATIONSALPHABETICAL
INDEX

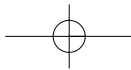

YOUR CAR

SAFETY

STARTING AND DRIVING

WARNING LIGHTS AND MESSAGES

IN AN EMERGENCY

MAINTENANCE AND CARE

TECHNICAL SPECIFICATIONS

ALPHABETICAL INDEX



WARNING

Rotating the key on MAR, the warning light  turns on for a few seconds, to remind that the passenger air bag will activate in the event of a collision, then it turns off.



WARNING

Front air bag activation if foreseen in case of more severe collisions compared with pretensioner activation. When the shock is within the two deployment thresholds, it is normal that pretensioners only are engaged.



WARNING

The airbag does not replace seat belts, but increases their efficiency. Furthermore, since front airbags are not deployed after low speed collisions, side collisions, rear-end shunts or roll-overs, the passengers are only protected by the seat belts which must be fastened at all times.



WARNING

Do not wash the seats with pressurized water or steam (manually or at the automatic washing stations).

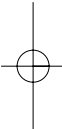
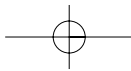

STARTING AND DRIVING

STARTING THE ENGINE	82
HANDBRAKE	84
USING THE MANUAL GEARBOX	85
CONTAINING RUNNING COSTS	86
SNOW TYRES.....	88
SNOW CHAINS.....	89
CAR INACTIVITY	89

YOUR CAR

SAFETY

STARTING AND DRIVING

WARNING LIGHTS AND MESSAGES

IN AN EMERGENCY

MAINTENANCE AND CARE

TECHNICAL SPECIFICATIONS

ALPHABETICAL INDEX

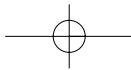

YOUR CAR

SAFETY

STARTING AND DRIVING

WARNING LIGHTS AND MESSAGES

IN AN EMERGENCY

MAINTENANCE AND CARE

TECHNICAL SPECIFICATIONS

ALPHABETICAL INDEX

STARTING THE ENGINE

The car is provided with an electronic engine lock device: refer to “The Ford CODE system” paragraph in “Your car” if you cannot start the engine.

The engine may be noisier during the first seconds of operation, particularly after a long period of inactivity. This does not impair functionality and reliability and is typical of hydraulic tappets: the distribution system selected for the petrol engines of your car in order to limit the maintenance required.



In the first period of use, we recommend to avoid excessive stress for the car (for instance excessive accelerations, extended travel at maximum speed, sudden braking etc.).



*With engine off, do not leave the key in the ignition switch on **MAR** to prevent draining the battery.*



WARNING

It is dangerous to have the engine running indoors. The engine depletes oxygen and discharges carbon dioxide, carbon monoxide and other toxic gases.



WARNING



Remember that the servobrake and electric power steering are not operational until the engine is started. Therefore, more effort than usual is required on the brake pedal and steering wheel.

STARTING PROCEDURE FOR PETROL VERSIONS

Proceed as follows:

- ensure that the handbrake is up;
- put the gear lever into neutral;
- press the clutch pedal all the way down without touching the accelerator;
- turn the ignition key to **AVV** and let it go the moment the engine starts.

If the engine does not start at the first attempt, return the ignition key to **STOP** before repeating starting.

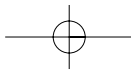

If with the ignition key on **MAR** the warning light  remains lit together with warning light , turn the key to **STOP** and then back to **MAR**; if the warning light remains on, try with the other keys provided with the vehicle.

Contact a Ford Dealership if you still cannot start the engine.



PROCEDURE FOR DIESEL VERSIONS

Proceed as follows:

- ensure that the handbrake is up;
- put the gear lever into neutral;
- turn the ignition key to **MAR**: warning light  on the instrument panel will come on;
- wait for the warning lights and  to turn off. The hotter the engine is, the quicker this will happen;
- press the clutch pedal all the way down without touching the accelerator;
- turn the ignition key to **AVV** as soon as the warning light  turns off. Waiting too long will waste the work done by the glow plugs.

Release the key as soon as the engine starts.

IMPORTANT When the engine is cold, rotating the ignition key to **AVV**, the accelerator pedal must be completely released.

If the engine does not start at the first attempt, return the ignition key to **STOP** before repeating starting.

If with the ignition key on **MAR**, the instrument panel warning light  remains on, turn the key to **STOP** and then back to **MAR**; if the warning light remains on, try with the other keys provided with the vehicle.

Contact the Ford Dealership if you still cannot start the engine.



Warning light  will blink for 60 seconds after starting or during prolonged cranking to indicate a fault to the glow plug heating system. Use the car normally if the engine starts and contact the Ford Dealership as soon as possible.

HOW TO WARM UP THE ENGINE AFTER IT HAS JUST STARTED

Proceed as follows:

- drive off slowly, letting the engine turn at medium speed. Do not accelerate abruptly;
- do not demand maximum performance for the first few kilometres. Wait until the engine coolant gauge starts moving.



Never jump start the engine by pushing, towing or driving downhill. This could cause a flow of fuel into the catalytic converter and damage it beyond repair.

YOUR CAR

SAFETY

STARTING AND DRIVING

WARNING LIGHTS AND MESSAGES

IN AN EMERGENCY

MAINTENANCE AND CARE

TECHNICAL SPECIFICATIONS

ALPHABETICAL INDEX

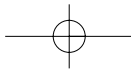

STOPPING THE ENGINE

Turn the ignition to **STOP** while the engine is idling.

IMPORTANT After a taxing drive, you should allow the engine to “catch its breath” before turning it off by letting it idle to allow the temperature in the engine compartment to fall.



A quick burst on the accelerator before turning off the engine serves absolutely no practical

purpose, it wastes fuel and is damaging especially to turbocharged engines.

HANDBRAKE

The handbrake lever is located between the two front seats.

Pull the lever upwards to operate the handbrake.



WARNING

The car must be braked after a few snaps of the lever, otherwise, contact the Ford Dealership for regulation.

When the handbrake lever is pulled up and the ignition key is on **MAR**, the instrument panel warning light (Ⓢ) will turn on.

Proceed as follows to release the handbrake:

- slightly lift the handbrake and press release button **A**-fig. 1;
- hold button **A** pressed and lower the lever. Warning light (Ⓢ) on the instrument panel will go out.

Press the brake pedal when carrying out this operation to prevent the car from moving accidentally.

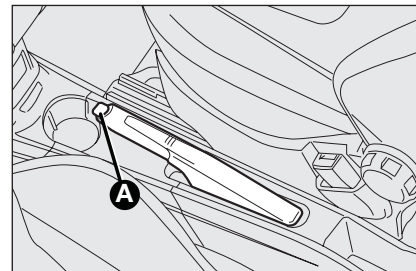

fig. 1

KA00059m

PARKING THE CAR

Proceed as follows:

- stop the engine and engage the handbrake;
- engage a gear (on a slope, engage first gear if the vehicle faces uphill or reverse if it faces downhill) and leave the wheels steered.

If the car is parked on a steep slope, it is further advisable to block the wheels with a wedge or stone.

Do not leave the ignition key on **MAR** to prevent draining the battery. Always remove the key when you leave the car.

Never leave children unattended in the car. Always remove the ignition key when leaving the car and take it out with you.

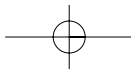

USING THE MANUAL GEARBOX

To engage the gears, press the clutch pedal fully and shift the gear lever into one of the required positions (the diagram is shown on the knob **fig. 2**).

For cars provided with 6 gear gearbox, to engage the sixth gear, operate the lever with a pressure toward the right to avoid involuntary engagement of fourth gear. Same action to pass from sixth to fifth gear.

IMPORTANT Reverse may only be engaged when the car is at a standstill. With the engine running, wait for at least 2 seconds with the clutch pedal fully pressed before engaging reverse to prevent damage to the gears and grating.

To engage reverse **R** from neutral, raise ring **A** under the knob and at the same time move the gearshift lever rightwards and then backward.

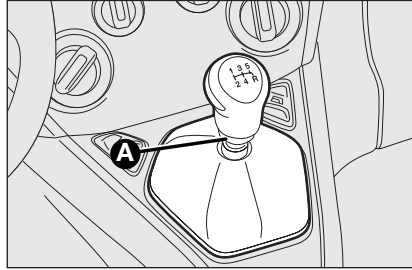

fig. 2

KA00060m

IMPORTANT Use of the clutch pedal must be limited solely to gear shifts only. Do not drive with your foot resting even lightly on the clutch pedal. For versions/markets where applicable, the clutch pedal control electronics could interpret an incorrect driving style as a fault.



WARNING

Press the clutch pedal fully to change gears correctly. For this reason, there must be no obstacles on the floor under the pedals: ensure that rubber mats (if any) are correctly positioned, not interfering with the pedals.



Do not drive with the hand resting on the gear lever, because this pressure, even if light, over time can wear gear inner components.

YOUR CAR

SAFETY

STARTING AND DRIVING

WARNING LIGHTS AND MESSAGES

IN AN EMERGENCY

MAINTENANCE AND CARE

TECHNICAL SPECIFICATIONS

ALPHABETICAL INDEX

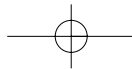

YOUR CAR

SAFETY

STARTING AND DRIVING

WARNING LIGHTS AND MESSAGES

IN AN EMERGENCY

MAINTENANCE AND CARE

TECHNICAL SPECIFICATIONS

ALPHABETICAL INDEX

CONTAINING RUNNING COSTS

Here are some useful tips to save fuel and minimize polluting emissions of CO₂ and other pollutants (nitric oxide, unburnt hydrocarbons, fine dusts etc...).

GENERAL CONSIDERATIONS

Car maintenance

Have checks and adjustments carried out in accordance with the "Service schedule".

Tyres

Check tyre pressure regularly at least once every four weeks: excessively low pressure will increase consumption because rolling resistance will be higher.

Unnecessary loads

Do not travel with an overloaded boot. Do not travel with too much luggage stowed in the boot. The weight of the car (especially when driving in town) and its trim greatly affect consumption and stability.

Accessories fitted on longitudinal bars

Remove accessories, namely: If not used, remove from the roof accessories such as: longitudinal bars, ski rack, luggage rack, etc. These accessories decrease aerodynamic penetration of the car and have a negative effect on consumption. It is better to use a trailer to transport particularly bulky objects.

Electric devices

Use electric devices only for the amount of time needed. The rear heated window, additional headlights, windscreen wipers and heater fan need a considerable amount of energy, therefore increasing fuel consumption (up to +25% in the urban cycle).

Climate control

The climate control system leads to higher fuel consumption (up to +20% on average): use air vents only when the external temperature allows it.

Spoilers

The use of non-certified aerodynamic items may adversely affect air drag and consumption levels.

DRIVING STYLE

Starting

Do not warm the engine up with the car standing: the engine warms up very slowly in these conditions, increasing consumption and emissions. It is advisable to start off immediately and slowly keeping the engine speed down: the engine will warm up much faster this way.

Unnecessary actions

Avoid revving up when starting at traffic lights or before stopping the engine. Like double-declutching, the latter action is unnecessary and causes increase of consumption and pollution.

Gear selection

Use a higher gear as soon as traffic and road conditions allow. Using a low gear for faster acceleration will increase consumption.

In the same way improper use of a high gear increases consumption, emissions an engine wear.

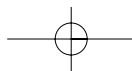

Top speed

Fuel consumption considerably increases as speed increases. Keep your speed as even as possible, avoiding unnecessary braking and acceleration which cause excessive fuel consumption and increase emissions.

Acceleration

Sudden acceleration has a very negative effect on consumptions and emissions: accelerate gradually.

CONDITIONS OF USE

Cold starting

Short distances and frequent cold start-ups will prevent the engine from reaching optimal running temperature. Consequently, both consumption (from +15 to +30% on urban cycle) and emissions will increase.

Traffic and road conditions

Quite high consumption is caused by heavy traffic, for instance when travelling in a queue with frequent use of low gears or in cities with many traffic lights. Mountain and rough roads also have a negative effect on consumption.

Traffic hold-ups

During prolonged hold-ups (e.g. level crossings) the engine should be switched off.

YOUR CAR

SAFETY

STARTING AND
DRIVINGWARNING
LIGHTS AND
MESSAGESIN AN
EMERGENCYMAINTENANCE
AND CARETECHNICAL
SPECIFICATIONSALPHABETICAL
INDEX

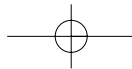

YOUR CAR

SAFETY

STARTING AND
DRIVINGWARNING
LIGHTS AND
MESSAGESIN AN
EMERGENCYMAINTENANCE
AND CARETECHNICAL
SPECIFICATIONSALPHABETICAL
INDEX

SNOW TYRES

Use snow tyres of the same size as the normal tyres provided with the car.

The Ford Dealership will be happy to provide advice concerning the most suitable type of tyre for the customer's requirements.

For the type of tyre to be used, inflation pressures and the specifications of snow tyres, follow the instructions given in paragraph "Wheels" in section "Technical specifications".

The performance of these tyres is considerably reduced when the tread thickness is less than 4 mm. Replace them in this case.

Due to their specific features, the performance of snow tyres is much lower than that of standard tyres in normal conditions or long motorway stretches. Limit performance according to the use for which they were approved.

IMPORTANT When snow tyres are used with a max speed index below the one that can be reached by the car (increased by 5%), place a notice in the passenger's compartment, plainly in the driver's view which states the max permissible speed of the snow tyres (as per EC Directive).

All four tyres should be the same (brand and track) to ensure greater safety when driving and braking and better driveability.

Remember that it is inappropriate to change the direction of rotation of tyres.



WARNING

Snow tyre maximum speed with "Q" mark must not exceed 160 km/h, respecting however the applicable rules of the Highway Code.

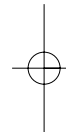
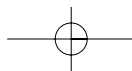

SNOW CHAINS

Use of snow chains should be in compliance with local regulations.

The snow chains may be applied only to the front wheel tyres (drive wheels).

Check the tension of the chains after the first few metres have been driven.

IMPORTANT The spare wheel cannot be fitted with snow chains. If the front tyre has a puncture, replace a rear wheel with the spare wheel and move the rear wheel to the front axle. This way, having two standard size wheels on the front axle, is it possible to fit the chains.



Keep your speed down when snow chains are fitted. Do not exceed 50 km/h. Avoid potholes, steps and pavements and avoid also to drive for long distances on roads not covered with snow to prevent damaging the car and the roadbed.

EXTENDED CAR INACTIVITY

If the car is to be left inactive for longer than a month, the following precautions should be noted:

- park the car in covered, dry and if possible well-ventilated premises;
- engage a gear;
- check that the handbrake is not engaged;
- disconnect battery negative terminal and check charge (see paragraph "Battery - Charge and electrolyte level check" in chapter "Maintenance and care")
- clean and protect the painted parts using protective wax;

YOUR CAR

SAFETY

STARTING AND DRIVING

WARNING LIGHTS AND MESSAGES

IN AN EMERGENCY

MAINTENANCE AND CARE

TECHNICAL SPECIFICATIONS

ALPHABETICAL INDEX

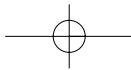

YOUR CAR

SAFETY

STARTING AND DRIVING

WARNING LIGHTS AND MESSAGES

IN AN EMERGENCY

MAINTENANCE AND CARE

TECHNICAL SPECIFICATIONS

ALPHABETICAL INDEX

- clean and protect the shiny metal parts using special compounds readily available;
- inflate tyres to +0.5 bar above the normal specified pressure and check it at intervals;
- sprinkle talcum powder on the rubber windscreen and rear window wiper blades and lift them off the glass;
- do not drain the engine cooling system.
- slightly open the windows;
- cover the car with a fabric or perforated plastic sheet. Do not use compact plastic sheets which do not allow humidity to evaporate from the surface of the car.

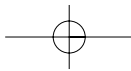
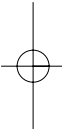

WARNING LIGHTS AND MESSAGES

GENERAL WARNINGS	92	REAR FOG LIGHTS	97
LOW BRAKE FLUID	92	GENERIC FAILURE INDICATION	97
HANDBRAKE ON	92	ENGINE OIL PRESSURE SENSOR FAILURE	97
AIRBAG FAILURE	92	WATER IN DIESEL FUEL FILTER	98
FRONT PASSENGER AIRBAG DEACTIVATED	93	FUEL CUT-OFF INERTIAL SWITCH INTERVENTION NOT AVAILABLE	98
HOT ENGINE COOLANT	93	EXTERNAL LIGHTS	98
LOW BATTERY CHARGE	94	PARKING SENSOR FAILURE	98
ABS SYSTEM FAILURE	94	ESP SYSTEM FAILURE	98
EBD SYSTEM FAILURE	94	HILL HOLDER FAILURE	98
LOW ENGINE OIL PRESSURE	94	TAIL LIGHTS AND LOW BEAMS	98
EXHAUSTED OIL	94	FOLLOW ME HOME	98
ELECTRIC POWER STEERING FAILURE	95	FRONT FOG LIGHTS	99
INCOMPLETE DOOR LOCKING	95	LEFT-HAND DIRECTION INDICATOR	99
INJECTION SYSTEM FAILURE	95	RIGHT-HAND DIRECTION INDICATOR	99
EOBD ENGINE CONTROL SYSTEM FAILURE (PETROL VERSIONS)	95	MAIN BEAM HEADLIGHTS	99
PARTICULATE TRAP CLOGGED	96	POSSIBLE ICE ON THE ROAD	99
FUEL RESERVE	96	SPEED LIMIT EXCEEDED	99
WARMING GLOW PLUGS	96	LIMITED RANGE	99
GLOW PLUG HEATING FAILURE	96	ASR SYSTEM	99
WATER IN DIESEL FUEL FILTER	97	BRAKE PAD WEAR	100
FAULT IN PROTECTION SYSTEM		SEAT BELTS NOT FASTENED	100
VEHICLE- FORD CODE	97	HEATED REAR WINDOW	100
		HEATED WINDSCREEN	100

YOUR CAR

SAFETY

STARTING AND DRIVING

WARNING LIGHTS AND MESSAGES

IN AN EMERGENCY

MAINTENANCE AND CARE

TECHNICAL SPECIFICATIONS

ALPHABETICAL INDEX

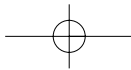

YOUR CAR

SAFETY

STARTING AND
DRIVINGWARNING
LIGHTS AND
MESSAGESIN AN
EMERGENCYMAINTENANCE
AND CARETECHNICAL
SPECIFICATIONSALPHABETICAL
INDEX

WARNING LIGHTS AND MESSAGES

GENERAL WARNINGS

Lighting of a warning light is associated to a specific message and/or buzzer when applicable. These indications are **brief and precautionary** and as such must not be considered as exhaustive and/or alternative to the information contained in the Owner's Handbook, which you are recommended to read carefully in all cases. Refer to the information in this section **in the event of a failure indication.**

IMPORTANT Failure indications on the display fall into either of two categories: **serious** failure and **less serious** failure.

Serious failures are indicated by a repeated and prolonged warning "cycle".

Less serious failures are indicated by a limited warning "cycle".

Press **MENU ESC** to stop the warning cycle in both cases. The warning light on the instrument panel will stay on until the cause of the fault is eliminated.



**LOW BRAKE FLUID
LEVEL (red)**

HANDBRAKE ON (red)

When the ignition key is moved to **MAR**, the warning light turns on and should go off after a few seconds.

Low brake fluid level

The warning light turns on when the level of the brake fluid in the reservoir falls below the minimum level due to possible leaks in the circuit.

On certain versions the dedicated message is displayed.



WARNING

If the warning light (ⓘ) turns on when travelling (on certain versions together with the message on the display) stop the car immediately and contact your Ford Dealership.

Handbrake on

The warning light turns on when the handbrake is on.

On certain versions, if the car is moving the buzzer will also sound.

IMPORTANT If the warning light turns on when travelling, check that the handbrake is not engaged.



**AIR BAG FAILURE
(amber)**

When the ignition key is moved to **MAR**, the warning light turns on and should go off after a few seconds.

The warning light stays on glowing steadily if there is a failure in the air bag system.

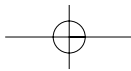

On certain versions the dedicated message is displayed.



**WARNING**

If when turning the key to **MAR** the warning light  does not turn on or stays on during car travel (together with the message on the multifunctional display, where provided), a failure may have occurred in the restraint systems. In this case the airbags or pretensioners may not be deployed after an impact or, in a minor number of cases, they may be deployed accidentally. Contact your Ford Dealership immediately to have the system checked before driving off.

**WARNING**





The failure of the warning light  (warning light off) is indicated by intermittent blinking of the warning light  that signals front passenger airbag deactivated.

**FRONT PASSENGER AIRBAG DISABLED (amber)**

The warning light  comes on when the front passenger's airbag is disabled.

With the front passenger's airbag on, when the ignition key is moved to **MAR**, the warning light  comes on steadily for about 4 seconds; then, it continues to flash for 4 seconds and finally goes off.

**WARNING**

Warning light  indicates failure of warning light . This condition is indicated by intermittent blinking of warning light  for longer than 4 seconds. In this case, warning light  may not indicate a fault in the system. Contact Ford Dealership immediately to have the system checked before driving off.

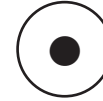
**HOT ENGINE COOLANT (red)** 

When the ignition key is moved to **MAR**, the warning light turns on and should go off after a few seconds.

The warning light turns on when the engine is overheated.

If the warning light comes on, proceed as follows:

- during normal travel:** stop the car, stop the engine and check that the water level in the vessel is not under the MIN line. In this case, wait for a few minutes for the engine to cool down, then slowly and carefully open the cap, top-up with coolant and check that the level is between the MIN and MAX references on the vessel itself. Also check for leakages. Should the warning light turn on again at the next start-up, contact your Ford Dealership.

YOUR CAR

SAFETY

STARTING AND DRIVING

WARNING LIGHTS AND MESSAGES

IN AN EMERGENCY

MAINTENANCE AND CARE

TECHNICAL SPECIFICATIONS

ALPHABETICAL INDEX

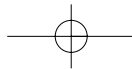

YOUR CAR

SAFETY

STARTING AND DRIVING

WARNING LIGHTS AND MESSAGES

IN AN EMERGENCY

MAINTENANCE AND CARE

TECHNICAL SPECIFICATIONS

ALPHABETICAL INDEX

- ❑ **If the vehicle is used under severe conditions** (e.g. towing of trailers uphill or fully loaded vehicle): slow down and stop the car if the warning light stays on. Stop for 2 or 3 minutes with the engine running and slightly accelerated to favour better coolant circulation. Then stop the engine. Check correct liquid level as described above.

IMPORTANT Under severe use of the vehicle, keep the engine on and slightly accelerated for a few minutes before switching it off.

On certain versions the dedicated message is displayed.

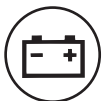

LOW BATTERY CHARGE (red)

When the ignition key is moved to **MAR**, the warning light turns on and should go out as soon as the engine is started (with the engine running at idle speed a brief delay in going out is allowed).

If the warning light stays on, immediately contact Ford Dealership.



ABS SYSTEM FAILURE (amber)

Turning the ignition key to **MAR** the warning light turns on, but it should go off after a few seconds.

The warning light lights up when the system is either not working or not available. In the case, the braking system will work as normal without the extra potentials offered by the ABS system. Drive carefully and go to a Ford Dealership as soon as possible.

On certain versions the dedicated message is displayed.



EBD FAILURE (red) (amber)

Simultaneous turning on of the warning lights (ⓘ) and (Ⓜ) while the engine is running indicates an EBD system failure or non-availability of the system. Early locking of the rear wheels may occur in the event of violent braking causing the vehicle to swerve. Drive very carefully to a Ford Dealership to have the system inspected.

On certain versions the dedicated message is displayed.



LOW ENGINE OIL PRESSURE (red)

EXHAUSTED OIL (Duratorq versions with DPF - red)

Low engine oil pressure

When the ignition key is moved to **MAR**, the warning light turns on and should go out as soon as the engine is started.

On certain versions the dedicated message is displayed.



WARNING

If the warning light  turns on when the car is travelling (on certain versions together with the message on the display) stop the engine immediately and contact a Ford Dealership.

Exhausted oil

The warning light turns on and flashes along with the message on the display when the system detects that the engine oil is exhausted.

After the first indication, whenever the engine is turned on, warning light  will continue to flash cyclically for 3 minutes with warning light OFF for 5 second intervals until the oil is replaced.

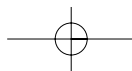

**WARNING**

If the warning light  flashes, contact the Ford Service Network immediately to change the engine oil and turn off the warning light on the instrument panel. Failure to comply with this requirement could render the warranty invalid.

**FAULT IN ELECTRIC POWER STEERING (amber)**

When the ignition key is turned to **MAR** the warning light turns on, but should go off after a few seconds.

If the warning light stays on, the power steering will not be effective and the steering wheel will be harder to turn, though it will still be possible to steer the car: contact the Ford service network.

On certain versions the dedicated message is displayed.

**INCOMPLETE DOOR LOCKING (red)**

The warning light comes on when one or more doors or the tailgate are not properly shut.

On certain versions the dedicated message is displayed.

When doors are open and the vehicle is in motion, a beep is emitted (only for versions with multifunction display).

**FAULT IN EOBD/INJECTION SYSTEM (amber)**

Under normal conditions, when the ignition key is turned to **MAR**, the warning light comes on, but should go off as soon as the engine is started.

If the warning light remains on or comes on whilst driving, this means that the injection system is not working properly; in particular, if the warning light comes on constantly, this indicates a malfunction in the supply/ignition system that could cause excessive exhaust emissions, a possible loss of performance, poor handling and high fuel consumption.

On certain versions the dedicated message is displayed.

Under these conditions, the vehicle can continue travelling at moderate speed without demanding excessive effort from the engine. Prolonged use of the car with the warning light steadily lit could cause damage. Contact the Ford Service Network as soon as possible.

The warning light goes out after the fault is cleared, but the information is stored in the system.

Only for petrol engines

A blinking warning light indicates possible damage to the catalytic converter.

YOUR CAR

SAFETY

STARTING AND DRIVING

WARNING LIGHTS AND MESSAGES

IN AN EMERGENCY

MAINTENANCE AND CARE

TECHNICAL SPECIFICATIONS

ALPHABETICAL INDEX

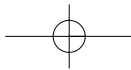

YOUR CAR

SAFETY

STARTING AND
DRIVINGWARNING
LIGHTS AND
MESSAGESIN AN
EMERGENCYMAINTENANCE
AND CARETECHNICAL
SPECIFICATIONSALPHABETICAL
INDEX

If the warning light is on with an intermittent light, release the accelerator pedal to reduce the speed until the warning light ceases to flash. Continue driving at a moderate speed, avoiding driving conditions that could cause further flashing and contact the Ford service network as soon as possible.



Go to a Ford Dealership as soon as possible if warning light  does not light up when the key is turned to

MAR or if, while travelling, the warning light comes on either steady or blinking (along with a message on the display). The operation of the warning light  may be checked by the traffic police using specific devices. Follow the laws in force in the country where you are driving.



PARTICULATE TRAP BLOCKED (1.3L Duratorq versions - wiring) (versions with multifunction display)

When the ignition key is moved to **MAR**, the warning light turns on and should go off after a few seconds.

The warning light turns on when the diesel particulate filter is clogged and the driving conditions do not enable to activate automatically the reclaiming procedure.

To allow the regeneration procedure and clean the filter, keep the vehicle running until the warning light turns off.

The display will show the dedicated message.



FUEL RESERVE (amber)

Turning the ignition key to **MAR** the warning light turns on, but it should go off after a few seconds.

The warning light turns on when about 5 litres of fuel are left in the tank.

IMPORTANT The warning light will blink to indicate a system failure. Go to a Ford Dealership to have the system checked.



GLOW PLUG HEATING (1.3L Duratorq versions - amber)

GLOW PLUG HEATING FAILURE (1.3L Duratorq versions - amber)

Glow plug warming

The warning light goes on when the key is turned to **MAR**. It goes out as soon as the glow plugs have reached the preset temperature. Start the engine as soon as the warning light goes out.

IMPORTANT With hot ambient temperature, warning light stays on for a very short time.

Glow plug warming failure

The warning light will blink in the event of a failure to the glow plug heating system. Go to a Ford Dealership as soon as possible.

On certain versions the dedicated message is displayed.

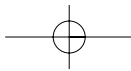





WATER IN DIESEL FUEL FILTER (1.3L Duratorq versions - amber)

When the ignition key is moved to **MAR**, the warning light turns on and should go off after a few seconds.

The warning light  turns on when there is water in the diesel fuel filter.

On certain versions the dedicated message is displayed.



The presence of water in the feeding circuit may cause severe damage to the injection system and irregular engine operation. If warning light  lights up (on some versions the warning light  along with the message), go to a Ford Dealership as soon as possible to have the system bled. Water may have been introduced in the tank if this appears immediately after refuelling: in this case, stop the engine immediately and contact a Ford Dealership.



FAULT IN PROTECTION SYSTEM VEHICLE- FORD CODE (red)

If with the ignition key at **MAR**, the warning light stays on, this indicates a possible failure (see “Ford Code system” in section “Your car”).

If with the engine running the warning light  flashes, this means that the car is not protected by the engine inhibitor device (see “Ford Code system” in section “Your car”).

Contact Ford Dealership to have all the keys stored.



REAR FOG LIGHTS (amber)

The warning light comes on when the rear fog lights are turned on.



GENERIC FAILURE INDICATION (amber)

The warning light turns on in the following circumstances.

Engine oil pressure sensor failure

The warning light turns on when failure is detected in parking sensors. Go to a Ford Dealership to have the fault fixed as soon as possible.

YOUR CAR

SAFETY

STARTING AND DRIVING

WARNING LIGHTS AND MESSAGES

IN AN EMERGENCY

MAINTENANCE AND CARE

TECHNICAL SPECIFICATIONS

ALPHABETICAL INDEX

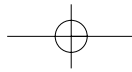

YOUR CAR

SAFETY

STARTING AND
DRIVINGWARNING
LIGHTS AND
MESSAGESIN AN
EMERGENCYMAINTENANCE
AND CARETECHNICAL
SPECIFICATIONSALPHABETICAL
INDEX

Fuel cut-off inertial switch intervention/fuel cut-off not available

The warning light turns on when the fuel cut-off inertial switch intervenes or when the fuel cut-off system is not available.

The display will show the dedicated message.

Parking sensor failure

The warning light turns on and the message is shown on the display when a parking sensor fault is detected Contact Ford Dealership.



ESP SYSTEM FAILURE (amber)

ESP system failure

When the ignition key is moved to **MAR**, the warning light turns on and should go off after a few seconds.

If the warning light does not go off or stays on when travelling together with the button led **ASR OFF**, contact Ford Dealership.

The display will show the dedicated message.

Note Warning light flashing when driving indicates that the ESP system is active.



HILL HOLDER FAILURE (amber)

When the ignition key is moved to **MAR**, the warning light turns on and should go off after a few seconds.

The warning light turns on to indicate a Hill holder system failure. In this case, contact Ford Dealership as soon as possible.

The display will show the dedicated message.



SIDE/TAILLIGHTS AND LOW BEAMS (green)

FOLLOW ME HOME (green)

Side/tail lights and low beams

The warning light comes on when side/tail lights or low beams are turned on.

Follow me home

The warning light will turn on when this device is active (see “Follow me home” in section “Your car”).

The display will show the dedicated message.



EXTERNAL (amber)

The warning light comes on when an external light failure is detected.

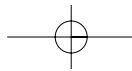



FRONT FOG LIGHTS (green)

The warning light turns on when the front fog lights are turned on.



LEFT-HAND DIRECTION INDICATOR (green - intermittent)

The warning light turns on when the direction indicator control lever is moved downwards or, together with the right indicator, when the hazard light button is pressed.



RIGHT-HAND DIRECTION INDICATOR (green - intermittent)

The warning light turns on when the direction indicator control lever is moved upwards or, together with the left indicator, when the hazard light button is pressed.



MAIN BEAMS (blue)

The warning light turns on when the main beams are turned on.



POSSIBLE PRESENCE OF ICE ON THE ROAD (versions with multifunctional display)

This indication starts flashing when the outside temperature reaches or falls below 4 °C to warn the driver of the possible presence of ice on the road.

The display will show the dedicated message.

SPEED LIMIT EXCEEDED

The display will show the dedicated message when the car exceeds the set speed limit (see “Reconfigurable Multifunction Display” in section “Your car”).

LIMITED RANGE (versions with multifunctional display)

The display will show the dedicated message to warn the driver that the cruising range is less than 50 km.

ASR SYSTEM (versions with multifunctional display)

The ASR system can be turned off by pressing the button **ASR OFF**.

When an event occurs, a dedicated message can appear on the display to inform the driver that the system has been switched off. The LED on the button will light up at the same time.

Pressing again button **ASR OFF** the button led will turn off and the display will provide the dedicated message to warn the driver that the system is on again.

YOUR CAR

SAFETY

STARTING AND DRIVING

WARNING LIGHTS AND MESSAGES

IN AN EMERGENCY

MAINTENANCE AND CARE

TECHNICAL SPECIFICATIONS

ALPHABETICAL INDEX

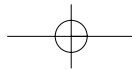

YOUR CAR

SAFETY

STARTING AND
DRIVINGWARNING
LIGHTS AND
MESSAGESIN AN
EMERGENCYMAINTENANCE
AND CARETECHNICAL
SPECIFICATIONSALPHABETICAL
INDEX

BRAKE PAD WEAR (amber)

The warning light on the dial turns on (and the message appears on the display) if the front brake pads are worn; in this case have them changed as soon as possible.



SEAT BELTS NOT FASTENED (red)

The warning light on the display will light up when the car is moving and the driver's seat belt is not correctly fastened. The warning light will go on blinking, and a steady beep will be emitted for the first 6 seconds when front seatbelts are not properly fastened and the vehicle is running; for the next 90 seconds the warning light will continue blinking and the beep will become intermittent.

The S.B.R. (Seat Belt Reminder) can only be turned off by the Ford service network. Contact a Ford Dealership to deactivate/reactivate the SBR system. The S.B.R. system can be reactivated via the display set-up menu if the vehicle is equipped with a multifunction display. The display will show the dedicated message.



FUEL RESERVE (amber)

The warning light turns on when the main beams are turned on.



HEATED WINDSCREEN (amber)

The warning light turns on when the heated windscreen is turned on.

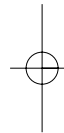
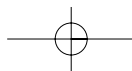

IN AN EMERGENCY

STARTING THE ENGINE	102
IF A TYRE IS PUNCTURED	104
QUICK TYRE REPAIR KIT FIX&GO automatic	110
WHEN NEEDING TO CHANGE A BULB	114
IF AN EXTERIOR LIGHT BURNS OUT	117
IF AN INTERIOR LIGHT BURNS OUT	120
FUSE REPLACEMENT	122
IF THE BATTERY IS FLAT	128
LIFTING THE CAR	129
TOWING THE CAR	129

YOUR CAR

SAFETY

STARTING AND
DRIVING

WARNING
LIGHTS AND
MESSAGES

**IN AN
EMERGENCY**

MAINTENANCE
AND CARE

TECHNICAL
SPECIFICATIONS

ALPHABETICAL
INDEX

STARTING THE ENGINE

If warning light  on the instrument panel stays lit with a fixed light, contact the Ford service network immediately.

JUMP STARTING

If the battery is flat, the engine may be started using an auxiliary battery with the same capacity or a little higher than the flat one.

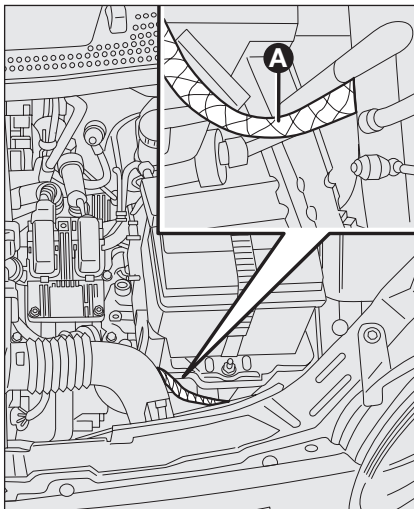

fig. 1a - Duratec versions

KA00136m

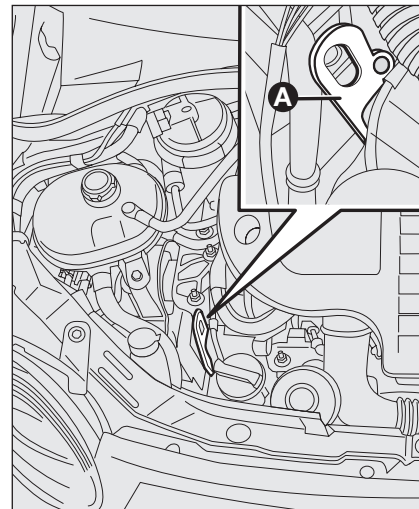

fig. 1b - Duratorq versions

KA00137m



Never use a quick battery charger for emergency starting: this might damage the electronic system and the engine start/supply control units.



WARNING

This procedure must be performed by expert personnel because incorrect actions may cause electrical discharge of considerable intensity. Furthermore, battery fluid is poisonous and corrosive: avoid contact with your skin and eyes. Keep naked flames away from the battery. No smoking. Do not cause sparks.

Proceed as follows:

- Connect positive terminals (+ sign near the terminal) of the two batteries with a jump lead;
- With a second lead, connect the negative terminal (-) of the auxiliary battery to an earthing point **A** of the car to be started (shown in **fig. 1a-1b**);
- Start the engine.
- When the engine has been started, follow the sequence above in reverse order to remove the leads.

If after a few attempts the engine does not start, do not insist any further but contact the nearest Ford Dealership.

IMPORTANT Never connect the negative terminals of the two batteries directly: sparks could ignite explosive gas released from the battery. If the auxiliary battery is installed on another car, prevent accidental contact between metallic parts of the two cars.

BUMP STARTING

Never jump start the engine by pushing, towing or driving downhill.

This could cause a flow of fuel into the catalytic converter and damage it beyond repair.

IMPORTANT Remember that the brake booster and the power steering system (if present) are not operating until the engine is started, a greater effort will therefore be required to press the brake pedal or turn the steering wheel.

YOUR CAR

SAFETY

STARTING AND
DRIVINGWARNING
LIGHTS AND
MESSAGESIN AN
EMERGENCYMAINTENANCE
AND CARETECHNICAL
SPECIFICATIONSALPHABETICAL
INDEX

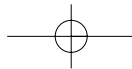

YOUR CAR

SAFETY

STARTING AND
DRIVINGWARNING
LIGHTS AND
MESSAGESIN AN
EMERGENCYMAINTENANCE
AND CARETECHNICAL
SPECIFICATIONSALPHABETICAL
INDEX

REPLACING A WHEEL

GENERAL INSTRUCTIONS

The vehicle can be supplied (if requested/provided for) with a normal spare wheel or with a small spare wheel.

For some versions/specifications, the vehicle is also equipped in the factory with 4 antitheft bolts (one per wheel).

To tighten/retighten the bolts, use the appropriate adaptor **A-fig. 2** provided, inserting between the bolt and wrench provided, as shown in **fig. 2**.

NOTE A duplicate of the bolts and special adaptor may be ordered from the Ford Service Network by providing the numerical reference code attached to the kit..

Wheel changing and correct use of the jack and of the small spare wheel call for some precautions as listed below.

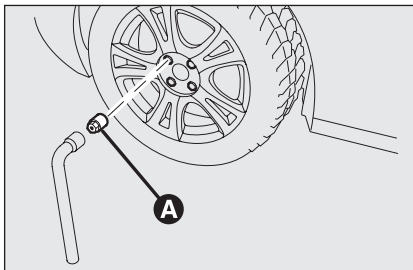

fig. 2

KA00120m



WARNING

The small spare wheel (if provided for) is specific for your car. Do not use it on cars of different models. Do not use spare wheels of different models on your car. The small spare wheel must only be used in an emergency. Never use it for more than strictly necessary and never exceed 80 km/h. On the small spare wheel there is an orange label, summarizing the main warnings regarding small spare wheel usage restrictions.



WARNING

The label must never be removed or covered under any circumstances. Never apply any hub cap on the small spare wheel. The label contains the following indications in four languages: Warning! For temporary use only! 80 km/h max! Replace as soon as possible with a standard service wheel. Never cover this indication.

If you choose to install wheels of a different type (with alloy rims instead of the steel ones) you must change all the fixing bolts with other of a suitable size.

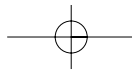

**WARNING**

Indicate the presence of a broken down vehicle in accordance with provisions in force: emergency lights, refracting warning triangle, etc. Passengers should leave the car, particularly if it is very loaded and wait for the wheel to be changed away from on-coming traffic. In case of steep slopes or rough slopes, place wedges or other materials suitable to stop the vehicle under the wheels.

When the small spare wheel is installed, the vehicle behaviour changes. Avoid violent accelerations and braking, sharp steering and fast bending. The overall duration of the small spare wheel is of about 3000 km, after which the relevant tyre must be replaced with another one of the same type. Never install a traditional tyre on a rim designed to be used as a small spare wheel. Repair and refit the standard wheel as soon as possible. Using two or more small spare wheels at the same time is forbidden. Do not apply grease to the bolt threading before assembly: they might come unscrewed.

**WARNING**

The jack may only be used to replace wheels on the car which it equips or other cars of the same model. Never use the jack for other purposes, such as lifting other car models. Never use the jack to carry out repairs under the car. Incorrect positioning of the jack may cause the car to fall. +Do not use the jack for loads higher than those shown on the label. Never install snow chains on the small spare wheel; if a front tyre (driving wheel) is punctured and you need to use snow chains, use a standard wheel from the rear axle and install the small spare wheel on the rear axle. This way, with two normal front driving wheels, you can install the snow chains on them, thus resolving the emergency.

The vehicle jack supplied with your vehicle should only be used when changing a wheel in emergency situations.

**WARNING**

If the hub cap is not installed properly, it can detach itself when the vehicle is running. Never tamper with the inflation valve. Never introduce tools of any kind between rim and tyre. Check tyre and small spare wheel pressure regularly referring to the values shown in the "Technical Specifications" chapter.

Important notes:

- the jack weight is 1.76 kg;
- the jack requires no adjustment;
- the jack cannot be repaired. If it breaks it must be replaced with a new jack;
- no tool other than the cranking device may be fitted on the jack.

YOUR CAR

SAFETY

STARTING AND
DRIVINGWARNING
LIGHTS AND
MESSAGES**IN AN
EMERGENCY**MAINTENANCE
AND CARETECHNICAL
SPECIFICATIONSALPHABETICAL
INDEX

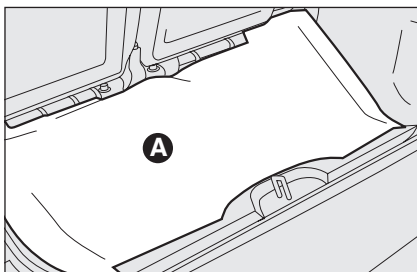

fig. 3

KA00062m

To change a wheel proceed as follows:

- stop the car in a position so that it is not a danger for on-coming traffic and where you can replace the wheel safely. The ground must be flat and compact.
- Turn the engine off and pull up the handbrake.
- Engage first gear or reverse;
- lift the boot mat **A**-fig. 3;

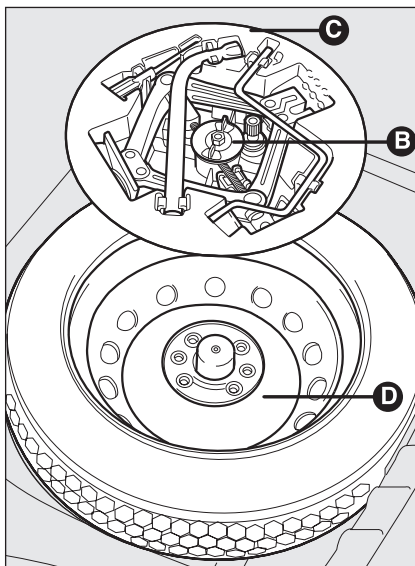

fig. 4

KA00063m

- loosen the fastener **B**-fig. 4;
- take out the tool container **C** and take it near to the wheel to be changed;
- take out the small spare wheel **D**;
- to remove the hub cap use the supplied screwdriver, prising on the special slit on the outer rim;

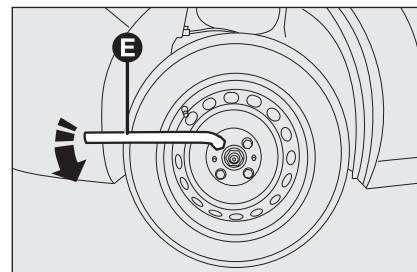

fig. 5

KA00064m

- for the vehicles equipped with alloy rims, remove the pressure-fitted hub cap using the supplied screwdriver;
- loosen by about one turn the fastening bolts of the wheel to be replaced with the wrench provided **E**-fig. 5;
- turn the jack handle to partially open it;

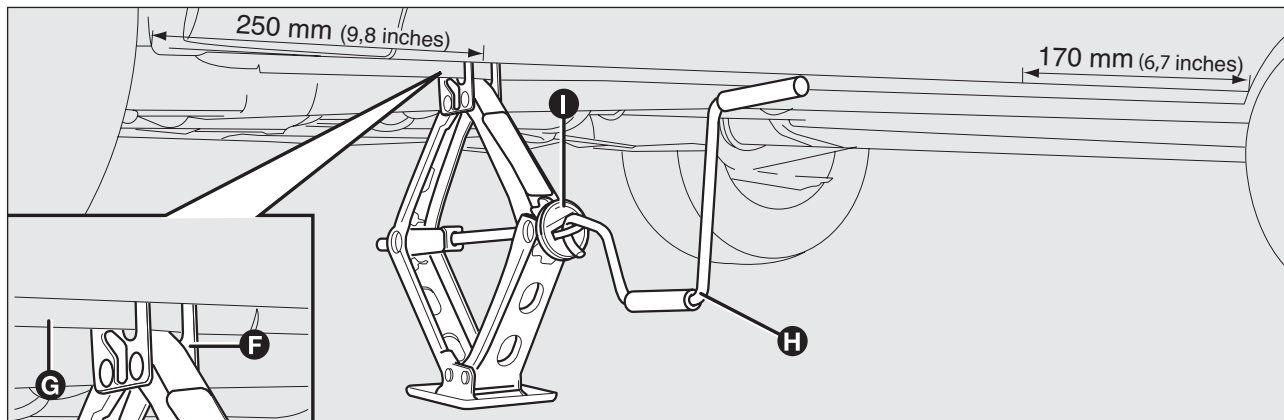

fig. 6

KA00065m

- position the jack near the wheel to be replaced at a distance of approximately 250 mm (9.8 inches) from the edge of the front wheel arch if a front wheel is to be replaced, or at a distance of 170 mm (6.7 inches) from the edge of the rear wheel arch if a rear wheel is to be replaced (as shown in the figure);
- make sure that the groove **F**-fig. 6 of the jack is well in contact with the tab **G** of the side member;
- warn anybody nearby that the car is about to be lifted. They must stay clear and not touch the car until it is back on the ground;
- fit the handle **H** into the device **I** of the jack and lift the car until the wheel to be changed is several centimetres off the ground. When turning the handle, make sure that it rotates freely, without risking to injure your hand by rubbing it against the ground. Even the moving components of the jack (screws and joints) can cause injuries; do not touch them. If you become fouled with lubricating grease, clean yourself thoroughly.
- make sure the rest surfaces between small spare wheel and hub are clean so that the fastening bolts will not come loose;

YOUR CAR

SAFETY

STARTING AND
DRIVINGWARNING
LIGHTS AND
MESSAGESIN AN
EMERGENCYMAINTENANCE
AND CARETECHNICAL
SPECIFICATIONSALPHABETICAL
INDEX

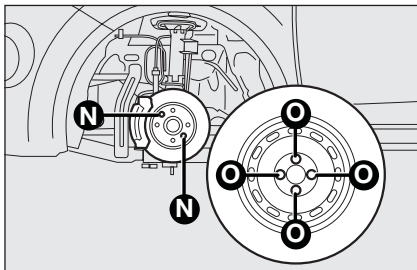
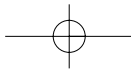

fig. 7

- install the small spare wheel aligning the pin **N**-fig. 7 with one of the wheel holes **O**;
- tighten the 4 fastening bolts;
- turn the jack handle to lower the car and remove the jack;
- fully tighten the bolts, passing alternatively from a bolt to the opposite one, following the order indicated in **fig. 8**.

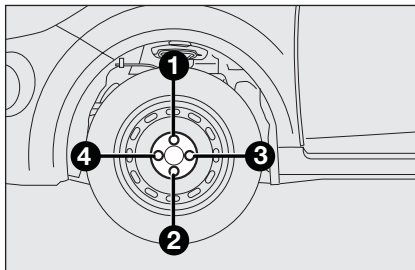

fig. 8

REFITTING THE STANDARD WHEEL

Following the procedure described previously, raise the car and remove the small spare wheel.

Versions with steel rims

Proceed as follows:

- make sure the contact surfaces between spare wheel and hub are clean and free from impurities so that the fastening bolts will not come loose;
- fit the spare wheel inserting the 4 bolts into the holes;
- Using the wrench provided, tighten the fastening bolts;

- pressure-fit the hub cap, aligning the special groove (on the cap itself) with the inflation valve;
- lower the car and remove the jack;
- Using the wrench provided, fully tighten the bolts in the sequence shown previously in the figure.

Versions with alloy rims

- Insert the wheel on the hub and using the wrench provided tighten the bolts;
- lower the car and remove the jack;
- Using the wrench provided, fully tighten the bolts in the sequence shown in **fig. 8**.
- reinstall the pressure-fitted hub cap, making sure that the reference hole on the wheel is aligned with the reference hole on the cap.

IMPORTANT If it is not fitted properly, the hub cap may detach itself when the vehicle is running.

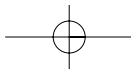

After tyre replacement

- stow the small spare wheel **D**-fig. 3 in the space provided in the boot;
- put the partially open jack back into its container **C**, forcing it slightly into its seat to prevent any vibrations during running;
- put the used tools back into the relevant seats provided in the container;
- stow the container, complete with tools, into the spare wheel, screwing in the locking device **B**;
- put back the boot mat into the proper position.

IMPORTANT Do not use an inner tube with tubeless tyres. Periodically check the pressure of the tyres and of the small spare wheel.

IMPORTANT If you choose to install wheels of a different type (with alloy rims instead of the steel ones or vice versa) you must change all the fixing bolts with others of a suitable size and use a specific small spare wheel, with different specifications.

It is advisable that you keep the replaced bolts and small spare wheel, as they are necessary if in future you decide to reinstall the original wheels.

ALPHABETICAL
INDEXTECHNICAL
SPECIFICATIONSMAINTENANCE
AND CAREIN AN
EMERGENCYWARNING
LIGHTS AND
MESSAGESSTARTING AND
DRIVING

SAFETY

YOUR CAR

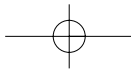

YOUR CAR

SAFETY

STARTING AND DRIVING

WARNING LIGHTS AND MESSAGES

IN AN EMERGENCY

MAINTENANCE AND CARE

TECHNICAL SPECIFICATIONS

ALPHABETICAL INDEX

TYRE REPAIR KIT

Your vehicle may not have a spare tyre.

In this case it will have an emergency tyre repair kit that can be used to repair one flat tyre.

The tyre repair kit is located in the spare wheel well.

GENERAL INFORMATION



WARNING

Depending on the type and extent of tyre damage, some tyres can only be partially sealed or not sealed at all. Loss of tyre pressure can affect vehicle handling, leading to loss of vehicle control.



WARNING

Do not use the tyre repair kit if the tyre has already been damaged as a result of being driven under inflated.



WARNING

Do not try to seal damage other than that located within the visible tread of the tyre.



WARNING

Do not try to seal damage to the tyre's sidewall.

The tyre repair kit seals most tyre punctures [with a diameter of up to six millimetres (1/4 inch)] to temporarily restore mobility.

Observe the following rules when using the kit:

- Drive with caution and avoid making sudden steering or driving manoeuvres**, especially if the vehicle is heavily loaded or you are towing a trailer.
- The kit will provide you with an emergency temporary repair, enabling you to continue your journey to the next vehicle or tyre dealer, or to drive a maximum distance of 200 kilometres (125 miles).

- Do not exceed a **maximum speed of 80 km/h (50 mph)**.
- Keep the kit out of the reach of children.
- Only use the kit when the ambient temperature is between -30°C (-22°F) and $+70^{\circ}\text{C}$ ($+158^{\circ}\text{F}$).

USING THE TYRE REPAIR KIT



WARNING

Compressed air can act as an explosive or propellant.



WARNING

Never leave the tyre repair kit unattended while in use.



WARNING

Do not keep the compressor operating for more than 10 minutes.

Note Use the tyre repair kit only for the vehicle with which it was supplied.

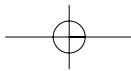

- Park your vehicle at the roadside so that you do not obstruct the flow of traffic and so that you are able to use the kit without being in danger.
- Apply the parking brake, even if you have parked on a level road, to make sure that the vehicle will not move.
- Do not attempt to remove foreign objects like nails or screws penetrating the tyre.
- Leave the engine running while the kit is in use, but not if the vehicle is in an enclosed or poorly ventilated area (for example, inside a building). In these circumstances, switch the compressor on with the engine turned off.
- Replace the sealant bottle with a new one before the expiry date (see top of bottle) is reached.
- Inform all other users of the vehicle that the tyre has been temporarily sealed with the tyre repair kit and make them aware of the special driving conditions to be observed.

INFLATING THE TYRE



WARNING

Check the sidewall of the tyre prior to inflation. If there are any cracks, bumps or similar damage, do not attempt to inflate the tyre.



WARNING

Do not stand directly beside the tyre while the compressor is pumping.



WARNING

Watch the sidewall of the tyre. If any cracks, bumps or similar damage appear, turn off the compressor and let the air out by means of the pressure relief valve I. Do not continue driving with this tyre.



WARNING

The sealant contains natural rubber latex. Avoid contact with skin and clothing. If this happens, rinse the affected areas immediately with plenty of water and contact your doctor.



WARNING

If the tyre inflation pressure does not reach 1.8 bar (26 psi) within 10 minutes, the tyre may have suffered excessive damage, making a temporary repair impossible. In this case, do not continue driving with this tyre.

YOUR CAR

SAFETY

STARTING AND
DRIVINGWARNING
LIGHTS AND
MESSAGESIN AN
EMERGENCYMAINTENANCE
AND CARETECHNICAL
SPECIFICATIONSALPHABETICAL
INDEX

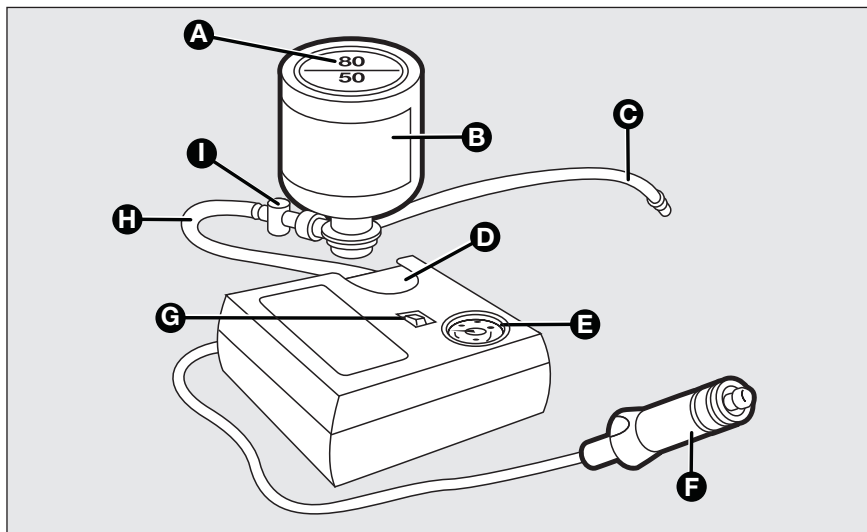
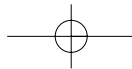

fig. 9

KA00128m

The kit **fig. 9** includes:

- A** Label
- B** Sealant bottle
- C** Sealant bottle hose
- D** Bottle holder
- E** Pressure gauge
- F** Power plug with cable
- G** Compressor switch
- H** Repair kit hose
- I** Pressure relief valve

1. Remove the tyre repair kit from the wrapping.
2. Peel off the label **A** showing the maximum permissible speed of 80 km/h (50 mph) from the sealant bottle and attach it to the instrument panel in the driver's field of view. Make sure the label does not obscure anything important.
3. Take the hose **H** with the pressure relieve valve **I** and the power plug with cable **F** out of the kit.

4. Connect the hose **H** with the pressure relieve valve **I** to the sealant bottle **B**.
5. Engage the sealant bottle **B** into the bottle holder **D**.
6. Remove the valve cap from the damaged tyre.
7. Screw the sealant bottle hose **C** firmly onto the valve of the damaged tyre.
8. Make sure that the compressor switch **G** is in position **0**.
9. Insert the power plug **F** into the cigar lighter socket or auxiliary power socket.
10. Start the engine.

11. Move the compressor switch **G** to position **1**.
12. Inflate the tyre for no longer than 10 minutes to an inflation pressure of minimum 1.8 bar (26 psi) and a maximum of 3.5 bar (51 psi). Move the compressor switch **G** to position **0** and check the current tyre pressure with pressure gauge **E**.

Note If a tyre pressure of 1.8 bar (26 psi) is not reached do not continue.

Note When pumping in the sealant through the tyre valve, the pressure may rise up to 6 bar (87 psi) but will drop again after about 30 seconds.

YOUR CAR

SAFETY

STARTING AND DRIVING

WARNING LIGHTS AND MESSAGES

IN AN EMERGENCY

MAINTENANCE AND CARE

TECHNICAL SPECIFICATIONS

ALPHABETICAL INDEX

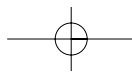

13. Remove the power plug **F** from the cigar lighter socket or auxiliary power socket.
14. Quickly unscrew the hose **C** from the tyre valve. Fasten the valve cap again.
15. Leave the sealant bottle **B** in the bottle holder **D**.
16. Make sure the kit is stored safely, but still easily accessible in the vehicle.
The kit will be required again when you check the tyre pressure.
17. Immediately drive approximately three kilometres (two miles) so that the sealant can seal the damaged area.



WARNING

If you experience heavy vibrations, unsteady steering behaviour or noises while driving, reduce your speed and drive with caution to a place where it is safe for you to stop the vehicle. Recheck the tyre and its pressure. If the tyre pressure is less than 1 bar (14.7 psi) or if there are any cracks, bumps or similar damage visible, do not continue driving with this tyre.

18. Stop the vehicle after driving approximately three kilometres (two miles). Check, and where necessary, adjust the pressure of the damaged tyre.
19. Attach the kit and read the tyre pressure from the pressure gauge **E**.
20. Adjust it to the specified pressure. See "Technical specifications".
21. Once you have inflated the tyre to its correct tyre pressure, move the compressor switch **G** to position **0**, remove the power plug **F** from the socket, unscrew the hose **C** and fasten the valve cap.
22. Leave hose **C** and **H** connected to the sealant bottle **B** and store the kit away safely.
23. Drive to the nearest tyre specialist to get the damaged tyre replaced. Before the tyre is removed from the rim, inform your tyre dealer that the tyre contains sealant. Renew the sealant bottle **B** and hose **C** as soon as possible after they have been used.

Note Remember that emergency roadside tyre repair kits only provide temporary mobility. Regulations concerning tyre repair after usage of tyre repair kit may differ from country to country. You should consult a tyre specialist for advice.



WARNING

Before driving, make sure the tyre is adjusted to the recommended inflation pressure. See Technical specifications. Monitor the tyre pressure until the sealed tyre is replaced.

Empty sealant bottles can be disposed of together with normal household waste.

Return remains of sealant to your dealer or dispose of it in compliance with local waste disposal regulations.

YOUR CAR

SAFETY

STARTING AND
DRIVINGWARNING
LIGHTS AND
MESSAGESIN AN
EMERGENCYMAINTENANCE
AND CARETECHNICAL
SPECIFICATIONSALPHABETICAL
INDEX

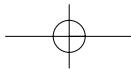

YOUR CAR

SAFETY

STARTING AND
DRIVINGWARNING
LIGHTS AND
MESSAGESIN AN
EMERGENCYMAINTENANCE
AND CARETECHNICAL
SPECIFICATIONSALPHABETICAL
INDEX

WHEN NEEDING TO CHANGE A BULB

GENERAL INSTRUCTIONS

- Before changing a bulb check the contacts for oxidation.
- Burnt bulbs must be replaced by others of the same type and power.
- Always check the height of the headlight beam after changing a bulb.
- When a bulb is not working, check that the corresponding fuse is intact before replacing it: refer to the “If a fuse blows” paragraph in this chapter for fuse location.



WARNING

Modifications or repairs to the electrical system that are not carried out properly or do not take the system's technical specifications into account can cause malfunctions leading to the risk of fire.



WARNING

Halogen bulbs contain gas under pressure, if they break glass fragments may be thrown around.



When handling halogen bulbs just touch the metal part. Touching the transparent part of the bulb with your fingers may reduce the intensity of the emitted light and even compromise duration of the lamp. In case of accidental contact, rub the lamp with a cloth and spirit and leave to dry.

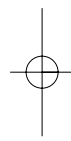
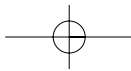



If possible, we recommend that you let Ford Dealership replace the lamps. Proper operation and orientation of the external lights are essential for the safety of the running vehicle, and for avoiding legal sanctions.

IMPORTANT A slight misting may appear on the internal surface of the headlight: this does not indicate a fault and is caused by low temperature and the degree of humidity in the air. Misting will rapidly disappear when the headlights are switched on. The presence of drops inside the headlights indicates infiltration of water. Go to a Ford Dealership.

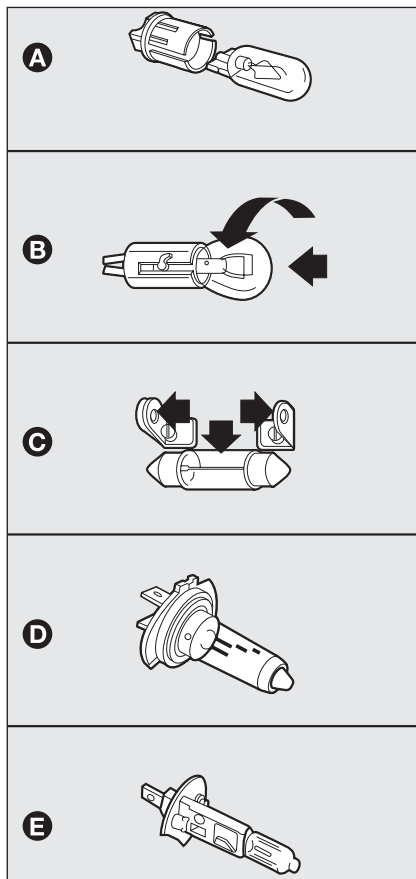

fig. 10

KA00110m

BULB TYPES fig. 10

Various types of bulbs are fitted to your car:

- A All glass bulb:** clipped into place. Pull to extract.
- B Bayonet bulbs:** to remove this type of bulb from its holder, press the bulb and turn it anticlockwise.
- C Cylindrical bulbs:** release from the contacts to extract.
- D Halogen bulbs:** release the fastening clip from the corresponding seat to remove the bulb.
- E Halogen bulbs:** release the fastening clip from the corresponding seat to remove the bulb.

YOUR CAR

SAFETY

STARTING AND
DRIVINGWARNING
LIGHTS AND
MESSAGESIN AN
EMERGENCYMAINTENANCE
AND CARETECHNICAL
SPECIFICATIONSALPHABETICAL
INDEX

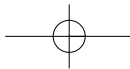

Bulb	Type	Power	Ref. figure
Main beam headlight	H4	55W	D
Dipped beam headlight	H4	55W	D
Front side lights/daytime lights	W5W	5W	A
Front direction indicators	PY21W	21W	B
Side direction indicators	W5W	5W	A
Rear direction indicators	PY21W	21W	B
Rear position	P21/5	21/5W	B
Stop	P21/5	21/5W	B
Reverse gear	P21W	21W	B
Rear fog lights	P21W	21W	B
Ceiling (courtesy) light	C10W	10W	C
Boot light	W5W	5W	A
Number plate lights	C5W	5W	C
Fog lights	H1	55W	E
Supplementary stop light (3rd stop)	W5W	5W	A

YOUR CAR

SAFETY

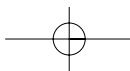
STARTING AND
DRIVINGWARNING
LIGHTS AND
MESSAGESIN AN
EMERGENCYMAINTENANCE
AND CARETECHNICAL
SPECIFICATIONSALPHABETICAL
INDEX

IF AN EXTERIOR LIGHT BURNS OUT

For the type of bulb and power rating, see “When needing to change a bulb”.

FRONT LIGHT CLUSTERS

The front light clusters contain sidelight, dipped beam, main beam and direction indicator bulbs.

The bulbs are arranged inside the light unit as follows **fig. 11**:

A sidelights

B dipped beams/main beams
(double light)

C direction indicators

Working from the engine compartment, remove rubber cap **D-fig. 12** to gain access to the sidelight bulbs; remove rubber cap **E-fig. 12** to gain access to the main/dipped beam lightlights; turn bulb holder **F-fig. 12** anticlockwise to gain access to the direction light bulbs.

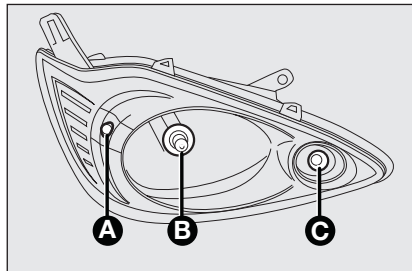

fig. 11

KA00085m

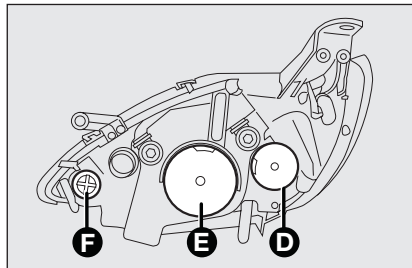

fig. 12

KA00086m

On some versions, it is necessary to remove the headlamp completely to replace the front light cluster bulbs.

To set the required unit proceed as follows:

- fully steer the wheels outwards to expose the flap **G-fig. 13**, open the flap and unscrew the fastening device;

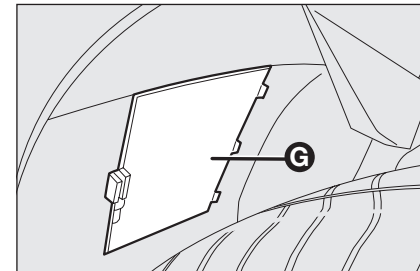

fig. 13

KA00117m

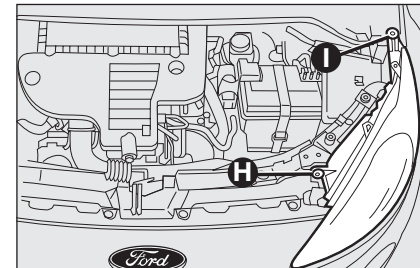

fig. 14

KA00118m

- after raising the bonnet, unscrew bolts **H** and **I** located at the points shown in **fig. 14**;

- remove the headlight.

YOUR CAR

SAFETY

STARTING AND DRIVING

WARNING LIGHTS AND MESSAGES

IN AN EMERGENCY

MAINTENANCE AND CARE

TECHNICAL SPECIFICATIONS

ALPHABETICAL INDEX

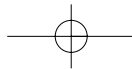

YOUR CAR

SAFETY

STARTING AND DRIVING

WARNING LIGHTS AND MESSAGES

IN AN EMERGENCY

MAINTENANCE AND CARE

TECHNICAL SPECIFICATIONS

ALPHABETICAL INDEX

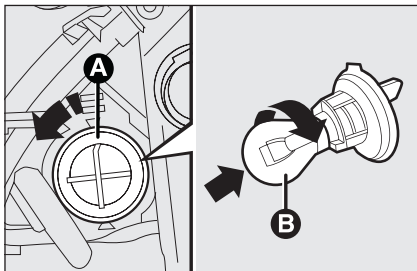

fig. 15

KA00087m

DIRECTION INDICATORS

Front

To change the bulb, proceed as follows:

- turn the bulb holder clockwise **A-fig. 15** and withdraw it;
- remove the bulb **B** pushing it gently and turning counterclockwise (bayonet fitting), then replace it;
- refit the bulb holder **A** by turning it clockwise and locking it properly;

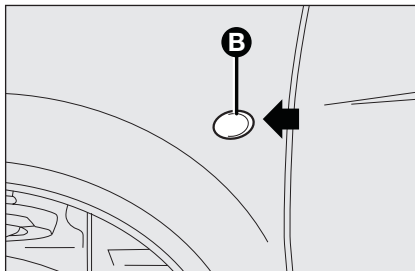

fig. 16

KA00088m

Side indicators

To change the bulb, proceed as follows:

- prise in the point indicated by the arrow, so as to compress the fixing clip and extract the assembly **B-fig. 16**;
- turn the bulb holder counterclockwise, remove the snap-fitted bulb and replace it;
- reinstall the bulb holder into the lens, then install the assembly **B** making sure that the fixing clip has clicked.

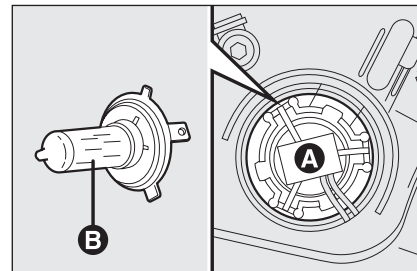

fig. 17

KA00089m

DIPPED/MAIN BEAMS

To change the bulb, proceed as follows:

- remove the protecting rubber cap mentioned above;
- press on the central electrical connector **A-fig. 17** and withdraw the assembly;
- remove the bulb **B** and replace it;
- fit the new bulb, making the outlines of the metallic part coincide with the grooves on the reflector;
- refit the bulb holder catches and reconnect the electrical connector;
- refit the cap **A** locking it properly.

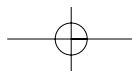

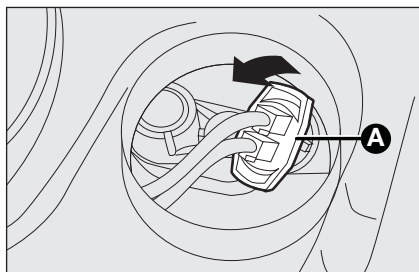

fig. 18

KA00090m

SIDELIGHTS - TAILLIGHTS

To change the bulb, proceed as follows:

- remove the protecting rubber cap mentioned above;
- turn the bulb holder clockwise **A-fig. 18** and withdraw it;
- remove the snap-fitted bulb and replace it;
- refit the bulb holder **A** by turning it clockwise and locking it properly;
- reinstall the rubber cap;

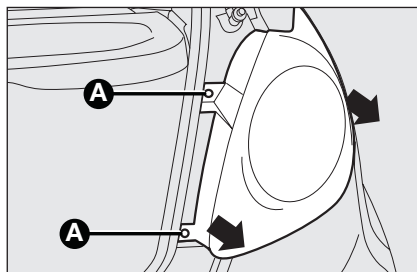

fig. 19

KA00104m

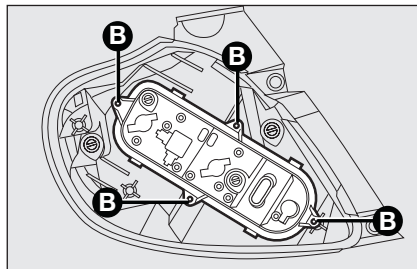

fig. 20

KA00105m

FRONT FOG LIGHTS (where provided)

IMPORTANT to replace the front fog lights you must contact the Ford Dealership.

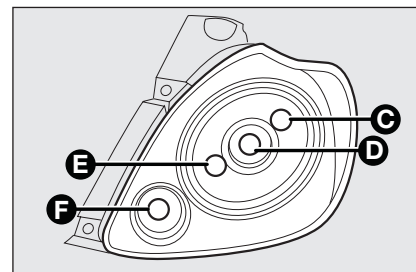

fig. 21

KA00106m

TAIL-LIGHT CLUSTERS

To change the bulb proceed as follows:

- open the tailgate;
- unscrew the two fastening screws **A-fig. 19** and extract the light cluster axially without rotating it;
- extract the bulb holder from its seat releasing it from the locking clips **B-fig. 20**;
- extract the bulbs by pushing them slightly and turning them counter-clockwise.

The bulbs are arranged as follows:
fig. 21:

- C** – Side/Brake (upper arch)
- D** – direction indicators
- E** – Side (lower arch)
- F** – Reverse gear (right tail-light) / rear fog guards (left light)

YOUR CAR

SAFETY

STARTING AND
DRIVINGWARNING
LIGHTS AND
MESSAGESIN AN
EMERGENCYMAINTENANCE
AND CARETECHNICAL
SPECIFICATIONSALPHABETICAL
INDEX

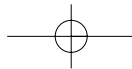

YOUR CAR

SAFETY

STARTING AND
DRIVINGWARNING
LIGHTS AND
MESSAGESIN AN
EMERGENCYMAINTENANCE
AND CARETECHNICAL
SPECIFICATIONSALPHABETICAL
INDEX

fig. 22

KA00091m

THIRD BRAKE LIGHT fig. 22-23

To change the bulb proceed as follows:

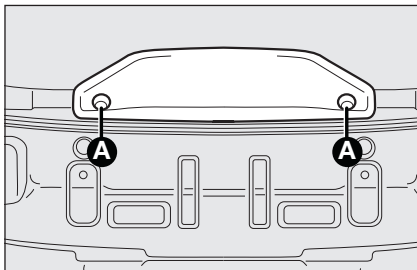
- tighten the 4 fastening bolts **A**;
- withdraw the assembly;
- disconnect the electric connector **B**;
- tighten the bulb holder after unscrewing the two fastening bolts:
- remove the press-fitted bulb to be replaced and replace it;
- tighten the bulb holder and retighten both bolts:
- tighten both fastening bolts **A**.

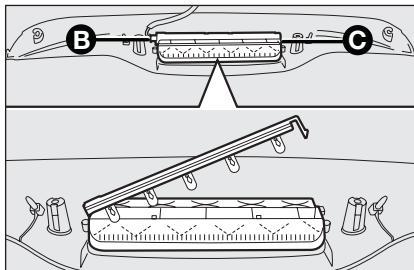

fig. 23

KA00092m

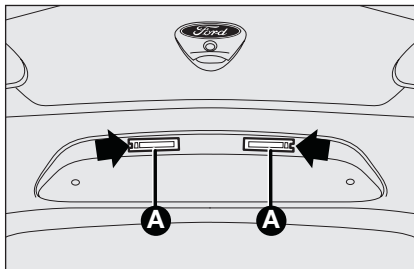

fig. 24

KA00093m

NUMBER PLATE LIGHTS fig. 24

To replace the bulbs proceed as follows:

- work in the point shown by the arrow and remove lens **A**;
- change the bulb releasing it from the side contacts and making sure the new bulb is correctly fastened between the contacts;
- reinstall the lens.

IF AN INTERIOR LIGHT BURNS OUT

For the type of bulb and power rating, see "When needing to change a bulb".

INSIDE CEILING LIGHT

To change the bulb, proceed as follows:

- using the screwdriver provided, extract the ceiling light **A**-fig. 25 working in the point indicated by the arrow;

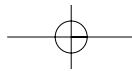

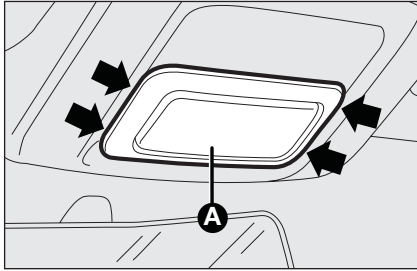

fig. 25

KA00094m

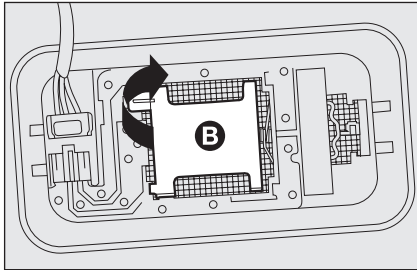

fig. 26

KA00095m

- open the cap **B**-fig. 26 as indicated;

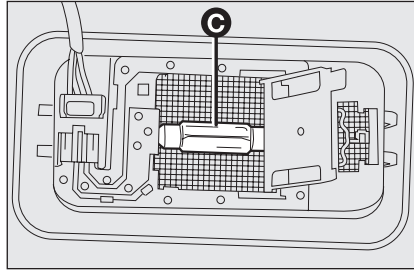

fig. 27

KA00096m

- replace bulb **C**-fig. 27 releasing it from the side contacts. Then, insert the new bulb making sure it is correctly clamped between the contacts;
- close the cap back and reinstall the lens.

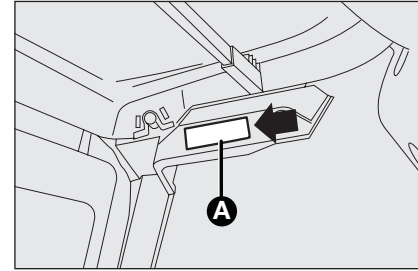

fig. 28

KA00097m

BOOT LIGHT (if present)

To change the bulb, proceed as follows:

- open the tailgate;
- using the screwdriver provided, extract the ceiling light **A**-fig. 28 working in the specified point.

YOUR CAR

SAFETY

STARTING AND
DRIVINGWARNING
LIGHTS AND
MESSAGESIN AN
EMERGENCYMAINTENANCE
AND CARETECHNICAL
SPECIFICATIONSALPHABETICAL
INDEX

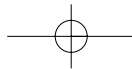

YOUR CAR

SAFETY

STARTING AND
DRIVINGWARNING
LIGHTS AND
MESSAGESIN AN
EMERGENCYMAINTENANCE
AND CARETECHNICAL
SPECIFICATIONSALPHABETICAL
INDEX

fig. 29

KA00098m

- open the bulb cover **B**-fig. 29 and replace the snap-fitted bulb **C**;
- re-close the bulb cover **B** on the lens;
- Reinstall the ceiling light properly inserting it into its seat on one side first, and then pressing the other side until it clicks into position.

IF A FUSE BLOWS

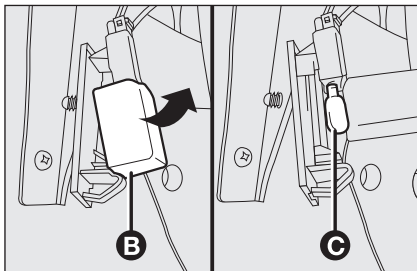
GENERALITIES fig. 30

The fuse is a protective device for the electric system: it comes into action (i.e. it cuts off) mainly due to a fault or improper action on the system.

Check the efficiency of the corresponding fuse when a device does not work: the conducting element **A** must not be interrupted. If it is, replace the blown fuse with a new one having the same amperage (same colour).

- B** intact fuse.
- C** fuse with damaged filament.

To replace a fuse use tweezers **D**, hooked inside the fuse compartment cover on the left side of the dashboard.

To identify the protection fuse, see the tables in the following pages.



WARNING

Should the fuse blow again, contact Ford Dealership.

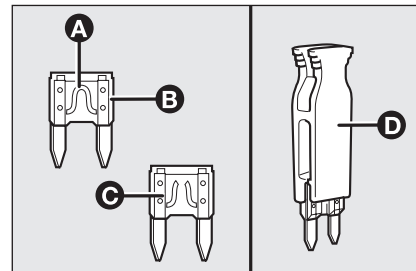

fig. 30

KA00099m



Never replace a blown fuse with metal wires or other materials.



WARNING

Never replace a fuse with another having higher amperage; FIRE HAZARD.

In case of general protection fuse intervention (MEGA-FUSE, MIDI-FUSE, MAXI-FUSE) contact Ford Dealership.

Remove the key from the ignition switch and switch off all loads before replacing a fuse.

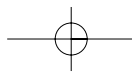

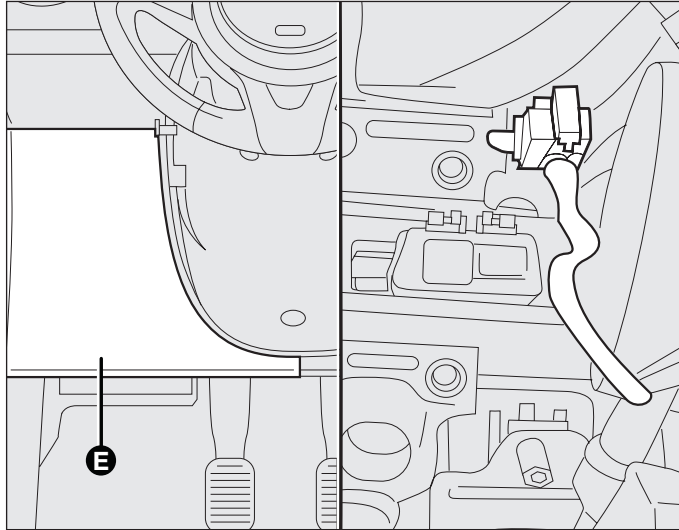

fig. 31

KA00107m

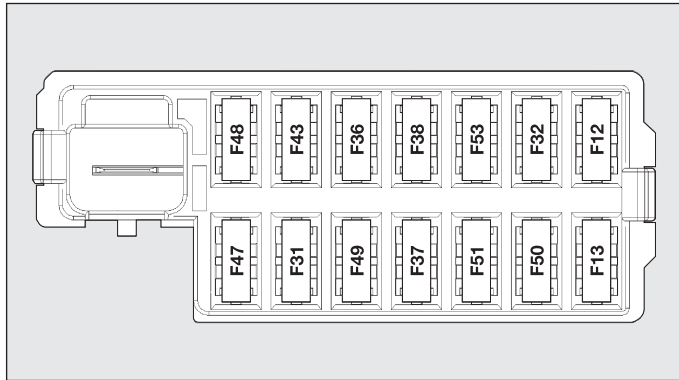

fig. 32

KA00100m

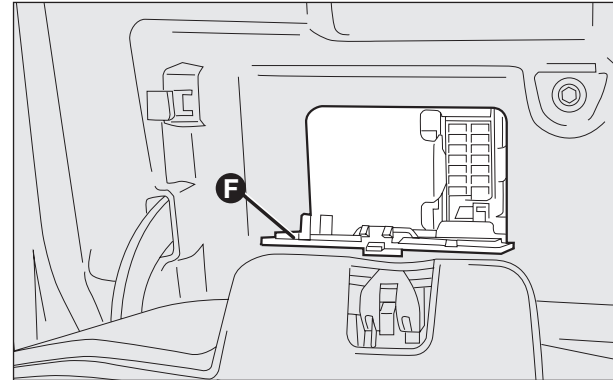

fig. 33

KA00125m

FUSE LOCATION

Dashboard fuses

Left-hand drive versions

To access the fuse you must remove the press-fitted cover **E**. The 5A fuse for door mirror demisting is located in the diagnostic socket area, as shown in **fig. 31**.

The control unit shown in **fig. 32** is present in the lower area, besides the pedals.

Right-hand drive versions

To gain access to the fuse box shown in **fig. 32**, open flap **F** located inside the glove compartment **fig. 33**.

YOUR CAR

SAFETY

STARTING AND
DRIVINGWARNING
LIGHTS AND
MESSAGESIN AN
EMERGENCYMAINTENANCE
AND CARETECHNICAL
SPECIFICATIONSALPHABETICAL
INDEX

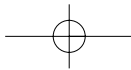

- YOUR CAR
- SAFETY
- STARTING AND DRIVING
- WARNING LIGHTS AND MESSAGES
- IN AN EMERGENCY
- MAINTENANCE AND CARE
- TECHNICAL SPECIFICATIONS
- ALPHABETICAL INDEX

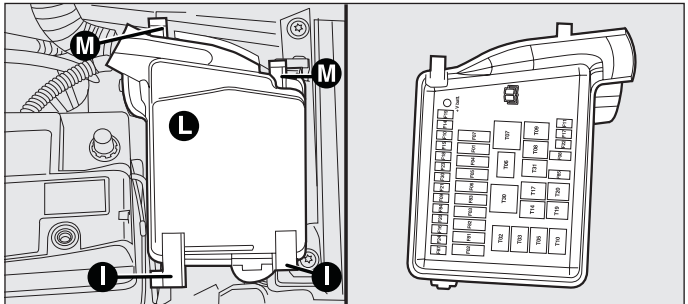

fig. 34 KA00101m

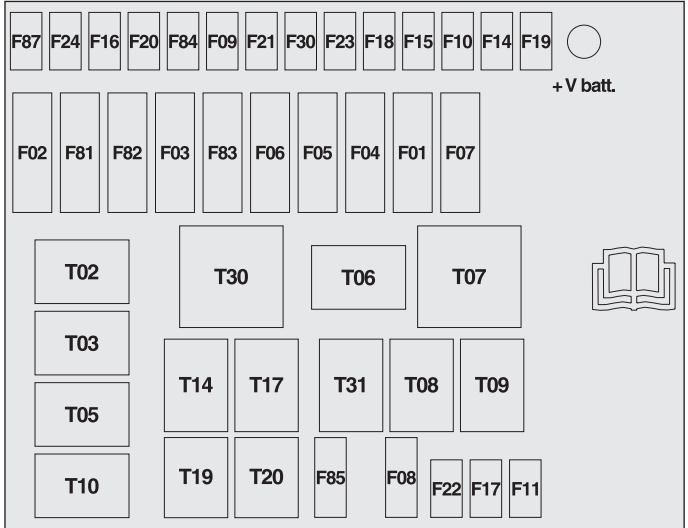

fig. 35 KA00102m

Engine compartment control unit fig. 34 e 35

A second control unit is located on the right side of the engine compartment, next to the battery; to access it press device **I**, release tabs **M** and remove cover **L**.

The ID number of the electrical component corresponding to each fuse can be found on the back of the cover.



If you need to wash the engine compartment, take care not to directly hit the engine compartment control unit with the water jet.

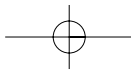

FUSE TABLE**Dashboard control unit - fig. 32**

	FUSE	AMPS
Right dipped beam power supply	F12	7.5
Left dipped headlight and headlight alignment control unit power supply	F13	7.5
Engine compartment junction unit switch	F31	5
Front and rear courtesy lights, boot and puddle lights	F32	7.5
Diagnostic socket, radio, climate control, EOBD	F36	10
Brake light switch, instrument panel node	F37	5
Door central locking	F38	20
Windscreen/ rear window washer pump	F43	15
Driver side power windows	F47	20
Passenger side power windows	F48	20
Parking sensor, backlighting switches, electric mirrors	F49	5
Airbag node	F50	7.5
Radio switch, convergence, climate control, brake lights, clutch	F51	7.5
Instrument panel node	F53	5

Engine compartment control unit - fig. 35

	FUSE	AMPS
Body computer control unit	F01	60
Subwoofer, hi-fi audio amplifier	F02	20
Ignition switch	F03	20
ABS control unit (pump power supply)	F04	40
EPS	F05	70
Single-speed engine cooling fan	F06	20
Single-speed engine cooling fan, low speed engine cooling fan	F06	30
High-speed engine cooling fan	F07	40
Climate control system fan	F08	30
Spare	F09	-
Horns	F10	15

YOUR CAR

SAFETY

STARTING AND
DRIVINGWARNING
LIGHTS AND
MESSAGESIN AN
EMERGENCYMAINTENANCE
AND CARETECHNICAL
SPECIFICATIONSALPHABETICAL
INDEX

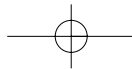

Engine compartment control unit - fig. 35

	FUSE	AMPS
Engine control system (secondary loads)	F11	10
Main headlights	F14	15
Heated seats	F15	15
+15 Engine control unit	F16	7.5
Engine control unit	F17	10
Engine control unit (1.2L Duratec)	F18	7.5
Engine control unit, relay coil (1.3L Duratorq)	F18	7.5
Conditioner compressor	F19	7.5
Heated rear window, mirror demisters	F20	30
Fuel pump	F21	15
Ignition coil, injectors (1.2L Duratec)	F22	15
Engine control unit (1.3L Duratorq)	F22	20
ABS control unit (Control unit power supply + Solenoids)	F23	20
+15 ABS control unit (pump power supply), EPS, yaw sensor	F24	7.5
Fog headlights	F30	15
Glow plug control unit (1.3L Duratorq)	F81	50
Spare	F82	-
Heated windscreen	F83	50
Spare	F84	-
Front socket (with or without cigar lighter plug)	F85	15
+15 for reversing lights, debimeter, presence of water in diesel sensor, relay coils T02, T05, T14 and T19	F87	7.5

YOUR CAR

SAFETY

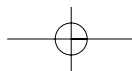
STARTING AND
DRIVINGWARNING
LIGHTS AND
MESSAGESIN AN
EMERGENCYMAINTENANCE
AND CARETECHNICAL
SPECIFICATIONSALPHABETICAL
INDEX

Engine compartment control unit - fig. 35

	RELÉ	AMPS
Main headlights	T02	20
Buzzers	T03	20
Conditioner compressor	T05	20
Single-speed engine cooling fan	T06	30
Low speed engine cooling fan		
High-speed engine cooling fan	T07	50
Climate control system fan	T08	30
Engine control system (main relay)	T09	30
Heated seats	T10	20
Fog headlights	T14	20
Fuel pump	T17	30
Demisting	T19	30
Spare	T20	-
Heated windscreen	T30	50
Front socket (with or without cigar lighter plug)	T31	30

YOUR CAR

SAFETY

STARTING AND
DRIVINGWARNING
LIGHTS AND
MESSAGESIN AN
EMERGENCYMAINTENANCE
AND CARETECHNICAL
SPECIFICATIONSALPHABETICAL
INDEX

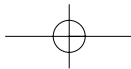

YOUR CAR

SAFETY

STARTING AND
DRIVINGWARNING
LIGHTS AND
MESSAGESIN AN
EMERGENCYMAINTENANCE
AND CARETECHNICAL
SPECIFICATIONSALPHABETICAL
INDEX

IF THE BATTERY IS FLAT

IMPORTANT The battery recharging procedure is provided as an example only. You are recommended to go to a Ford Dealership to have this operation performed.

We recommend recharging the battery slowly for approximately 24 hours at low amperage. A prolonged recharge might damage the battery.

Charge the battery as follows:

- disconnect battery negative terminal;
- connect the charger cables to the battery terminals, observing the poles;

- turn on the charger;
- when you have finished, turn the charger off before disconnecting the battery;
- reconnect battery negative terminal.



WARNING

Battery fluid is poisonous and corrosive: avoid contact with your skin and eyes. The battery recharging operation must be performed in a ventilated place, away from naked flames or possible sources of sparks to avoid the risk of explosion and fire.



WARNING

Don't try to recharge a frozen battery: defrost it first to prevent the risk of explosion. If a battery was frozen, have it inspected by specialised personnel before recharging to check that the internal elements are not damaged and that the casing is not cracked causing the risk of leakage of poisonous, corrosive gas.

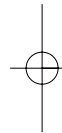
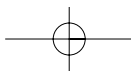

LIFTING THE CAR

If the car is to be lifted, go to a Ford Dealership which is equipped with the arm hoist or workshop lift.

TOWING THE CAR

The tow ring provided with the car is housed in the tool box under the boot mat.

FASTENING THE TOW RING fig. 36

Proceed as follows:

- release the cap **A**;
- take the tow hook **B** from its seat in the tool support;
- tighten the ring on the rear or front threaded pin.

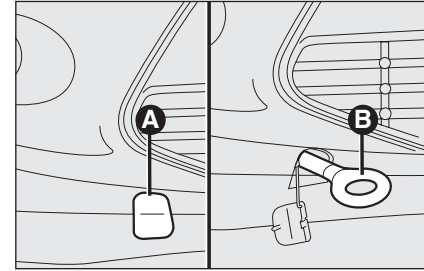

fig. 36

KA00076m



WARNING

Before beginning the tow, turn the ignition key to MAR and then to STOP, without extracting it. If the key is extracted, the steering wheel lock will be automatically activated, thus preventing steering.

YOUR CAR

SAFETY

STARTING AND
DRIVING

WARNING
LIGHTS AND
MESSAGES

IN AN
EMERGENCY

MAINTENANCE
AND CARE

TECHNICAL
SPECIFICATIONS

ALPHABETICAL
INDEX

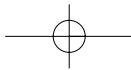

YOUR CAR
SAFETY
STARTING AND DRIVING
WARNING LIGHTS AND MESSAGES
IN AN EMERGENCY
MAINTENANCE AND CARE
TECHNICAL SPECIFICATIONS
ALPHABETICAL INDEX



WARNING

The power brakes and the electrical power steering will not work while the car is being towed. More effort on the brake pedal and steering wheel will therefore be required.

Do not use wires for towing. Do not jerk. Make sure not to damage parts in contact with the car while towing.

Respect the specific rules of the Highway Code when towing the car specifically in relation to the towing device and the behaviour to maintain on the road.

Do not start the engine while towing the car.

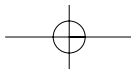
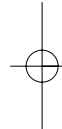

MAINTENANCE AND CARE

CHECKING FLUID LEVELS	132
AIR CLEANER	137
POLLEN FILTER	137
BATTERY	137
WHEELS AND TYRES.....	139
RUBBER HOSES.....	140
WINDSCREEN/REAR WINDOW WIPERS	141
BODYWORK	142
INTERIORS	144

YOUR CAR

SAFETY

STARTING AND
DRIVING

WARNING
LIGHTS AND
MESSAGES

IN AN
EMERGENCY

**MAINTENANCE
AND CARE**

TECHNICAL
SPECIFICATIONS

ALPHABETICAL
INDEX

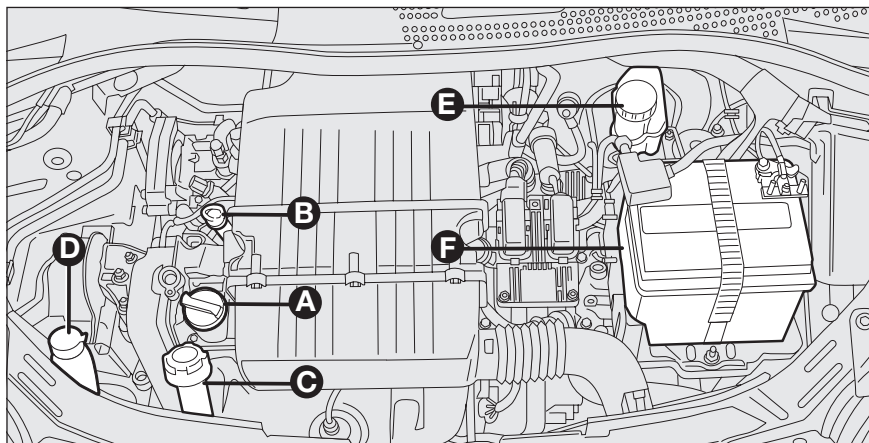

fig. 1 - 1.2L Duratec versions

KA00077m

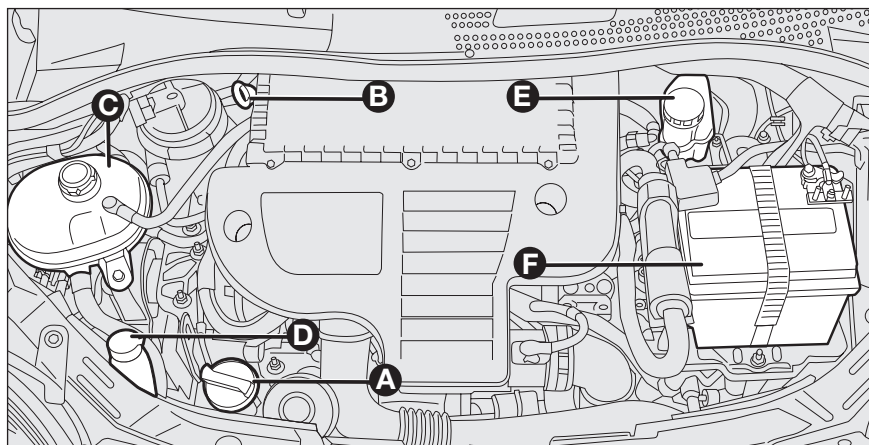

fig. 2 - 1.3L Duratorq versions

KA00078m

CHECKING FLUID LEVELS

Left-hand drive versions

- A. Engine oil filler fitting
- B. Engine oil level dipstick
- C. Engine coolant
- D. Windscreen washer fluid
- E. Brake fluid
- F. Battery



WARNING

Never smoke while working in the engine compartment. there might be flammable gases and vapours, with fire hazards.



When topping up, pay attention not to confuse the various types of fluids: they are all reciprocally incompatible and may severely damage your car.

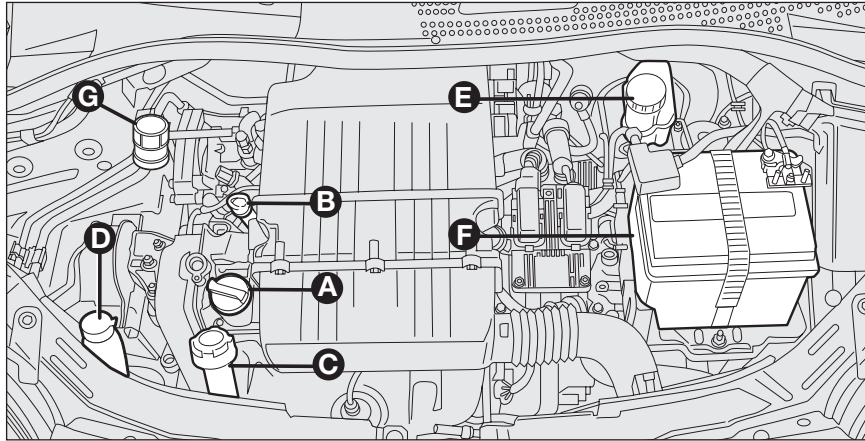

fig. 3 - 1.2L Duratec versions

KA00123m

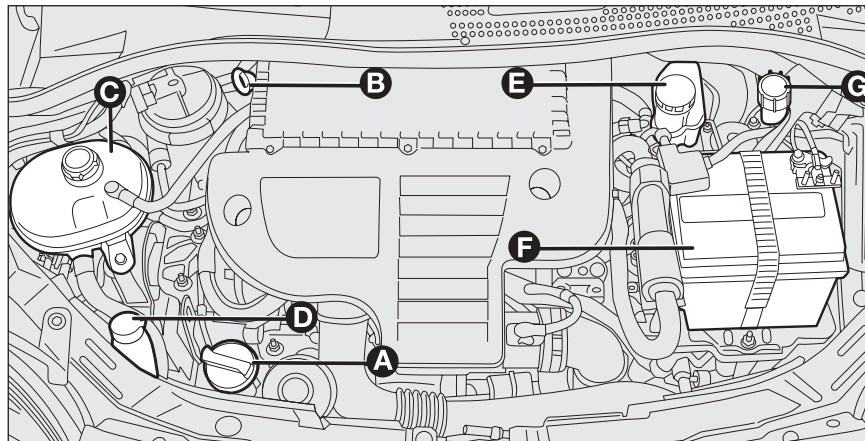

fig. 4 - 1.3L Duratorq versions

KA00124m

Right-hand drive versions

- A. Engine oil filler fitting
- B. Engine oil level dipstick
- C. Engine coolant
- D. Windscreen washer fluid
- E. Brake fluid
- F. Battery
- G. Brake fluid



WARNING

Never smoke while working in the engine compartment. there might be flammable gases and vapours, with fire hazards.



When topping up, pay attention not to confuse the various types of fluids: they are all reciprocally incompatible and may severely damage your car.

YOUR CAR

SAFETY

STARTING AND DRIVING

WARNING LIGHTS AND MESSAGES

IN AN EMERGENCY

MAINTENANCE AND CARE

TECHNICAL SPECIFICATIONS

ALPHABETICAL INDEX

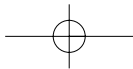

YOUR CAR

SAFETY

STARTING AND
DRIVINGWARNING
LIGHTS AND
MESSAGESIN AN
EMERGENCYMAINTENANCE
AND CARETECHNICAL
SPECIFICATIONSALPHABETICAL
INDEX

ENGINE OIL fig.1-2-3

Check the oil level a few minutes (about 5) after the engine has stopped, with the car parked on level ground.

The oil level shall be included between the MIN and MAX marks on the dipstick **B**.

The range between the MIN and MAX levels corresponds to approximately 1 litre of oil.

If the oil level is near or even under the MIN line, add oil through the filler **A** to reach the MAX line.

Oil level shall never exceed the MAX line.

Engine oil consumption

The maximum engine oil consumption is usually 400 grams every 1000 km.

When the car is new, the engine needs to be run in, therefore the engine oil consumption can only be considered stabilised after the first 5,000 - 6,000 km.

IMPORTANT The oil consumption depends on driving style and the conditions under which the car is used.

IMPORTANT After adding or changing the oil, let the engine turn over for a few seconds and wait a few minutes after turning it off before you check the level.



WARNING

Proceed very carefully inside the engine compartment when the engine is hot: risk of burns. Remember that the fan may start up if the engine is hot: risk of injury. Pay attention to scarves, ties and other loose fitting garments: they might get caught by moving components.



Don't add any oil having different characteristics from those of the existing engine oil.



The exhausted engine oil and the replaced oil filter contain substances that may be dangerous for the environment. It is advisable to have oil and filters changed by a Ford Dealership where they will be disposed of according to the law.

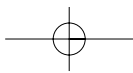

ENGINE COOLANT fig. 1-2-3

The coolant level must be checked when the engine is cold and must be between the MIN and MAX lines on the vessel.

If the level is low, pour slowly through the filler neck **C** a mixture of 50% demineralised water and 50% ARTECO Havoline XLC cooling fluid until the level reaches MAX.

A 50-50 mixture of ARTECO Havoline XLC cooling fluid and distilled water gives freeze protection to -35°C.

When the vehicle is used under particularly harsh weather conditions, we recommend using a 60-40 mixture of ARTECO Havoline XLC cooling fluid and demineralised water.

**WARNING**

Take great care when adding coolant. Avoid spillage on any part of the engine.



The antifreeze is used in the engine cooling system. Use fluid of the same type contained in the cooling system for top-ups. ARTECO Havoline XLC cooling fluid may not be mixed with other types of fluids. If this accidentally occurs, do not start the engine and contact a Ford Dealership.

**WARNING**

The engine cooling system is pressurized. If required, replace the cap with an original spare part so as not to compromise system efficiency. Do not remove the cap from the vessel when the engine is hot: Burn hazard.

**WARNING**

Proceed very carefully inside the engine compartment when the engine is hot: risk of burns.

WINDSCREEN/REAR WINDOW WASHER FLUID fig. 1-2-3

To add fluid, remove the cap **D**, pressing the special tab.

Pour a mixture of water and/or additive according to the supplier specifications.

Check level through the reservoir.

Close the cap **D** pressing its central section.

**WARNING**

Do not travel with the windscreen washing reservoir empty: the windscreen washer is fundamental to improve visibility.

Some commercial windscreen washer additives are flammable. The engine compartment contains hot parts which could start a fire if they come into contact.

YOUR CAR

SAFETY

STARTING AND
DRIVINGWARNING
LIGHTS AND
MESSAGESIN AN
EMERGENCYMAINTENANCE
AND CARETECHNICAL
SPECIFICATIONSALPHABETICAL
INDEX

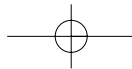

YOUR CAR

SAFETY

STARTING AND
DRIVINGWARNING
LIGHTS AND
MESSAGESIN AN
EMERGENCYMAINTENANCE
AND CARETECHNICAL
SPECIFICATIONSALPHABETICAL
INDEX

BRAKE FLUID fig. 1-2-3

Release cap **E**: Check that the liquid contained in the tank is at the maximum level.

Fluid level in the reservoir must not exceed the **MAX** mark.

Use the brake fluid shown in the “Fluids and lubricants” table (see “Technical Specifications”).

NOTE Carefully clean the cap of reservoir **E** and the surrounding surface.

When opening the cap, make sure that no dirt gets into the reservoir.

For topping up always use a funnel with built-in filter (mesh smaller than or equal to 0.12 mm).

IMPORTANT Brake fluid is hygroscopic (i.e. it absorbs moisture). For this reason, if the car is mainly used in areas with a high degree of atmospheric humidity, the fluid should be replaced at more frequent intervals than specified in the “Service schedule”.



Prevent brake fluid which is highly corrosive from coming into contact with painted parts. Should that occur, immediately wash with water.



WARNING
The brake fluid is poisonous and highly corrosive. In case of accidental contact, wash the parts with water and mild soap and rinse with plenty of water. If swallowed immediately call a doctor.



WARNING

The symbol © on the container indicates a synthetic brake fluid, which is different from a mineral fluid. Use of a mineral type fluid will damage the special rubber seals of the braking system beyond repair.

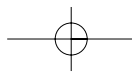

AIR CLEANER/ POLLEN FILTER

Have the air cleaner or the pollen filter replaced by a Ford Dealership.

DIESEL FUEL FILTER

DISCHARGE OF THE CONDENSATE (Duratorq versions)



The presence of water in the feeding circuit may cause severe damage to the injection system and irregular engine operation. If the warning light  goes on, contact the Ford Dealership as soon as possible to have the system bled. Water may have been introduced in the tank if this appears immediately after refuelling: in this case, stop the engine immediately and contact a Ford Dealership.

BATTERY

The car fits a low-maintenance battery: no top-ups with distilled water are needed in normal conditions of use.

INSPECTING THE CHARGE AND THE ELECTROLYTE LEVEL

Inspection operations must be carried out by specialised personnel, following the prescriptions contained in the Owner Handbook. ANY top-up operations must be carried out by specialised personnel and by a Ford Dealership.



WARNING

The battery fluid is poisonous and corrosive. Avoid contact with the skin and eyes. Keep naked flames and sources of sparks away from the battery: risk of explosion and fire.



WARNING

Running the battery with an excessively low liquid level will damage the battery beyond repair and even cause an explosion.

CHANGING THE BATTERY

If required, replace the battery with a genuine spare part having the same specifications.

If a battery with different specifications is fitted, the service intervals given in the "Service schedule" in this section will no longer be valid.

Refer therefore to the instructions provided by the battery manufacturer.

YOUR CAR

SAFETY

STARTING AND
DRIVINGWARNING
LIGHTS AND
MESSAGESIN AN
EMERGENCYMAINTENANCE
AND CARETECHNICAL
SPECIFICATIONSALPHABETICAL
INDEX

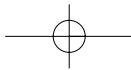

YOUR CAR

SAFETY

STARTING AND
DRIVINGWARNING
LIGHTS AND
MESSAGESIN AN
EMERGENCYMAINTENANCE
AND CARETECHNICAL
SPECIFICATIONSALPHABETICAL
INDEX

Incorrect assembly of electric and electronic devices may cause severe damage to your car. Go to a

Ford Dealership if you want to install accessories (alarms, mobile phone, etc.): they will suggest the most suitable devices and advise you if a higher capacity battery needs to be installed.



Batteries contain substances that can be very dangerous for the environment. It is advisable to have the

battery changed by a Ford Dealership where it will be disposed of according to the law.



WARNING

If the vehicle must remain unused for a long time at very low temperature, remove the battery and carry it to a warm place, to avoid freezing.



WARNING

When you must perform any operation on the battery or near it, always protect your eyes with special goggles.

USEFUL ADVICE FOR LENGTHENING THE LIFE OF YOUR BATTERY

To avoid draining your battery and make its life longer, observe the following indications:

- when you park the car, ensure the doors, tailgate and bonnet are closed properly;
- switch off all lights inside the vehicle: the car is however equipped with a system which switches all internal lights off automatically;
- do not keep accessories (e.g. sound system, emergency lights, etc.) switched on for a long time when the engine is not running;
- before performing any operation on the electrical system, disconnect the battery negative cable;
- battery terminals shall always be perfectly tightened.

IMPORTANT If the charge level remains for a long time under 50%, the battery is damaged by sulphating, reducing its capacity and starting attitude.

The battery will also be more at risk of freezing (e.g. already at -10°C). Refer to the paragraph "Vehicle inactivity" in "Starting and driving" if the vehicle is left parked for a long time.

If after buying the car, you want to install electric accessories which require permanent electric supply (alarm, etc.) contact your Ford Dealership whose qualified personnel, in addition to suggesting the most suitable devices, will evaluate the overall electric absorption, checking whether the car's electric system is capable of withstanding the load required, or whether it should be integrated with a more powerful battery.

Since these devices continue absorbing energy even when the ignition key is off, they gradually run down the battery.

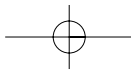

WHEELS AND TYRES

Check the pressure of each tyre, including the spare wheel, approximately once every two weeks and before starting a long journey: this check must be performed with the tyre rested and cold.

It is normal for pressure to increase when the car is used. For the correct tyre inflation pressure, see “Wheels” in “Technical specifications” section.

Wrong pressure causes abnormal wear of tyres **fig. 5**:

- A** normal pressure: evenly worn tread.
- B** low pressure: tread particularly worn on the edges.
- C** excessive pressure: tread particularly worn in the middle.

The tyres must be replaced when the tread is less than 1.6 mm thick. In all cases, follow the laws in force in the country where you are driving.

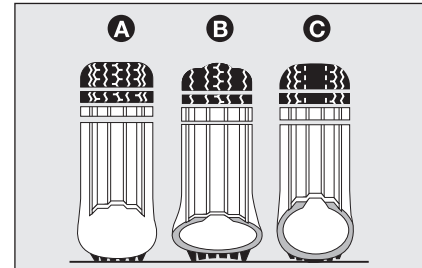

fig. 5

KA00081m

IMPORTANT NOTES

- Avoid braking suddenly, burning starts and violent knocks against the curb, potholes or other obstacles if possible. Long distances on rough roads may damage the tyres;
- check the tyres regularly for cuts on the sides, swelling or irregular tread wear. Go to a Ford Dealership if required;
- Do not overload your vehicle: this may cause serious damage to wheels and tyres;
- if a tyre is punctured, stop the vehicle immediately and charge it to avoid damage to the tyre, the rim, suspensions and steering system;

YOUR CAR

SAFETY

STARTING AND DRIVING

WARNING LIGHTS AND MESSAGES

IN AN EMERGENCY

MAINTENANCE AND CARE

TECHNICAL SPECIFICATIONS

ALPHABETICAL INDEX

YOUR CAR

SAFETY

STARTING AND
DRIVINGWARNING
LIGHTS AND
MESSAGESIN AN
EMERGENCYMAINTENANCE
AND CARETECHNICAL
SPECIFICATIONSALPHABETICAL
INDEX

- a tyre will age even if it is not used much. Cracks in the tread and on the sidewalls are a sign of ageing. Have the tyres checked by specialised personnel if they have been fitted for longer than 6 years. Remember to check the spare wheel very carefully;
- In case of replacement, always fit new tyres, avoiding those with an unknown origin.
- If a tyre is replaced, also change the inflation valve.
- to allow even wear between the front and rear tyres, it is advisable to change them over every 10-15 thousand kilometres, keeping them on the same side of the car so as not to reverse the direction of rotation.

**WARNING**

Remember that the road holding qualities of your car also depends on the correct inflation pressure of the tyres.

**WARNING**

If the pressure is too low the tyre will get overheated, with the risk of serious damages.

**WARNING**

Avoid moving the tyres from the right side of the vehicle to the left side and vice versa.

**WARNING**

Do not repaint alloy wheel rims at temperatures higher than 150°C. The mechanical characteristics of the wheels might be disrupted.

RUBBER HOSES

As far as the brake system and fuel rubber hoses are concerned, carefully follow the "Service schedule" in this section.

Ozone, high temperatures and prolonged lack of fluid in the system may cause hardening and cracking of the hoses, with possible leaks. Careful inspections are therefore necessary.

WINDSCREEN/ REAR WINDOW WIPERS

BLADES

Periodically clean the rubber part using special products.

Replace the blades if the rubber edge is deformed or worn. In all cases, it is advisable to replace them approximately once a year.

A few simple precautions can reduce the possibility of damage to the blades:

- make sure that the rubber part is not stuck to the windscreen at sub-zero temperatures. Use an antifreeze product to release it if required.
- remove the snow from the window: this will avoid overstressing the electrical motor in addition to protecting the blades;
- do not operate the windscreen and the rear screen wipers on dry glass.



WARNING

Driving with worn wiper blades is a serious hazard, because visibility is reduced in bad weather.

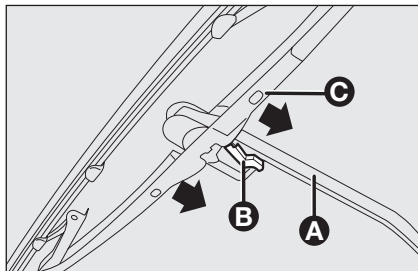

fig. 6

KA00115m

Replacing the windscreen wiper blades fig. 6

Proceed as follows:

- lift the arm **A** of the wiper and position the blade so that it forms an angle of 90° with the arm itself;
- press lever **B** and remove brush **C** from arm **A** pushing down as indicated by the arrows;
- insert the new blade making sure it is locked.

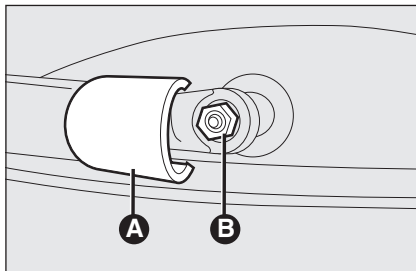

fig. 7

KA00082m

Changing the rear window blade fig. 7

Proceed as follows:

- raise the cover **A** and remove the arm from the car, slackening the nut **B** that fastens it to the pivot pin;
- fit the new arm, positioning it correctly, and fully tighten the nut;
- lower the cover.

YOUR CAR

SAFETY

STARTING AND
DRIVINGWARNING
LIGHTS AND
MESSAGESIN AN
EMERGENCYMAINTENANCE
AND CARETECHNICAL
SPECIFICATIONSALPHABETICAL
INDEX

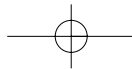

YOUR CAR

SAFETY

STARTING AND
DRIVINGWARNING
LIGHTS AND
MESSAGESIN AN
EMERGENCYMAINTENANCE
AND CARETECHNICAL
SPECIFICATIONSALPHABETICAL
INDEX

fig. 8

KA00079m

SPRAY NOZZLES

Windscreen washer fig. 8

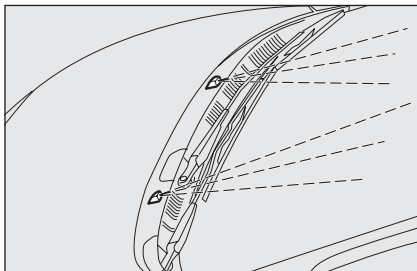
If the jet of fluid is inadequate, firstly check that there is fluid in the reservoir: see "Checking fluid levels" in this section).

Then check that the nozzle holes are not clogged, if necessary use a needle.

The windscreen jets are directed by adjusting the angle of the nozzles.

Fluid jets shall be directed at about $\frac{1}{3}$ height from the window upper edge.

IMPORTANT On versions with sun-roof, ensure the roof is closed before operating the front jets.

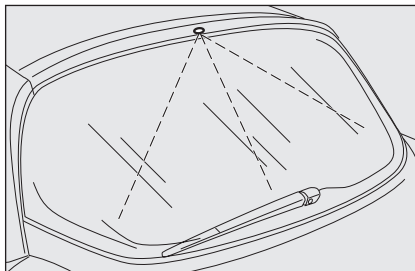

fig. 9

KA00080m

Rear window wiper fig. 9

Rear window washer jets are fixed.

The nozzle holder is on the rear window.

BODYWORK

PROTECTION FROM ATMOSPHERIC AGENTS

The main causes of corrosion are the following:

- atmospheric pollution;
- salty air and humidity (coastal areas or hot humid climates);
- seasonal environment conditions.

Not to be underestimated is also the abrasive action of wind-borne atmospheric dust and sand and mud and gravel raised by other cars.

On your car, Ford implemented the best manufacturing technologies to effectively protect the bodywork against corrosion.

These are the most important technologies:

- Painting products and systems which give the car particular resistance to corrosion and abrasion;
- use of galvanised (or pre-treated) steel sheets with high resistance to corrosion;
- spraying the underbody, engine compartment, wheelhouse internal parts and other parts with highly protective wax products;

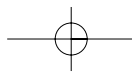

- spraying of plastic parts with a protective function in the more exposed points: underdoor, inner fender parts, edges, etc.;
- use of “open” boxed sections to prevent condensation and pockets of moisture from triggering rust inside.

BODY AND UNDERBODY WARRANTY

Your car is covered by warranty against perforation due to rust of any original element of the structure or body.

For the general terms of this warranty, refer to your Warranty Booklet.

ADVICE FOR PRESERVING THE BODYWORK

Paint

Paintwork does not only serve an aesthetic purpose, but also protects the underlying sheet metal.

Touch up abrasions and scratches immediately to prevent the formation of rust. Only use genuine spare paint products for touch-ups (see “Bodywork paint identification plate” in the “Technical Specifications” section).

Normal maintenance of paintwork consists in washing the vehicle: the frequency depends on the conditions and environment where the vehicle is used. For example, it is advisable to wash the car more often in areas with a high environmental pollution or on roads sprinkled with salt.

To correctly wash the car:

- remove the aerial from the roof to prevent damage to it if the car is washed in an automatic system;
- if high pressure jets or cleaners are used to wash the vehicle, hold at least 40 cm away from the bodywork to avoid damage or alteration. It should be remembered that a build up of water could cause damage, in the long term, to the car.
- wash the body using a low pressure jet of water;
- wipe a sponge with a slightly soapy solution over the bodywork, frequently rinsing with the sponge;
- rinse well with water and dry with a jet of air or a chamois leather.

Dry the less visible parts particularly carefully, such as the door frames, bonnet and the headlight frames, where water may stagnate more easily. It is a good idea to leave the car in the open for a while after washing it to give time for the water to evaporate.

Do not wash the car after it has been parked in the sun or when the engine is hot: this could take the shine off the paint.

Exterior plastic parts must be cleaned in the same way as the rest of the car.

Where possible, do not park under trees; the resinous substance many species release give the paint a dull appearance and increase the possibility of triggering rust processes.

IMPORTANT Bird droppings must be washed off immediately and thoroughly as the acid they contain is particularly aggressive.



Detergents cause water pollution. The car should be washed in areas equipped for collecting and purifying the liquid used in the washing process.

YOUR CAR

SAFETY

STARTING AND DRIVING

WARNING LIGHTS AND MESSAGES

IN AN EMERGENCY

MAINTENANCE AND CARE

TECHNICAL SPECIFICATIONS

ALPHABETICAL INDEX

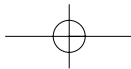

YOUR CAR

SAFETY

STARTING AND
DRIVINGWARNING
LIGHTS AND
MESSAGESIN AN
EMERGENCYMAINTENANCE
AND CARETECHNICAL
SPECIFICATIONSALPHABETICAL
INDEX

Windows

Use specific window cleaner products.

Use also clean cloths to avoid scratching the glass or damaging the transparency.

IMPORTANT Wipe the rear window inside gently with a cloth in the direction of the filaments to avoid damaging the heating device.

Engine compartment

At the end of each winter, thoroughly wash the engine compartment taking care not to direct the water jet against the electronic control units and the relay/fuse control unit on the left side of the engine compartment (running direction). Have this operation performed at a specialised workshop.

IMPORTANT Perform this operation on a cold engine and with the key at **STOP**. After the washing operation, make sure that the various protections (e.g. rubber caps and guards) have not been removed or damaged.

Front headlights

IMPORTANT Never use aromatic substances (e.g.: petrol) or ketenes (e.g.: acetone) for cleaning front headlight plastic lens.

EQUIPMENT

Periodically check that water is not trapped under the mats (due to water dripping off shoes, umbrellas, etc.) which could cause oxidisation of the sheet metal.



WARNING

Never use flammable products, such as petrol ether or rectified petrol to clean inside the car. The electrostatic charges which are generated by rubbing during the cleaning operation may cause a fire.



WARNING

Don't keep aerosol cans in the vehicle: risk of explosion. Aerosol cans must not be exposed to a temperature exceeding 50°C. When the vehicle is exposed to sunlight, inner temperature can greatly exceed this value.

CLEANING SEATS AND FABRIC PARTS

Remove dust with a soft brush or a vacuum cleaner.

Rub the seats with a sponge moistened with a solution of water and neutral detergent.

INTERIOR PLASTIC PARTS

It is advisable to clean interior plastic parts with a moist cloth and a solution of water and mild soap. Use specific products for cleaning plastic, without solvents and specifically designed to prevent damage to the appearance and colour of the treated parts to remove grease and tough stains.

IMPORTANT Never use spirit or petroleum to clean the instrument panel.

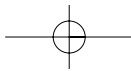

TECHNICAL SPECIFICATIONS

IDENTIFICATION DATA	146
ENGINE CODES - BODYWORK VERSIONS	148
ENGINE	149
FUEL FEED/IGNITION	150
TRANSMISSION	150
BRAKES	151
SUSPENSIONS	151
STEERING	151
WHEELS	152
DIMENSIONS	155
PERFORMANCE	156
WEIGHTS	157
CAPACITIES	158
FLUIDS AND LUBRICANTS	159
FUEL CONSUMPTION	161
CO ₂ EMISSIONS	162

YOUR CAR

SAFETY

STARTING AND
DRIVINGWARNING
LIGHTS AND
MESSAGESIN AN
EMERGENCYMAINTENANCE
AND CARETECHNICAL
SPECIFICATIONSALPHABETICAL
INDEX

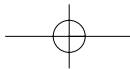

YOUR CAR

SAFETY

STARTING AND
DRIVINGWARNING
LIGHTS AND
MESSAGESIN AN
EMERGENCYMAINTENANCE
AND CARETECHNICAL
SPECIFICATIONSALPHABETICAL
INDEX

IDENTIFICATION DATA

We recommend taking note of the identification codes. The following identification codes are printed and shown on the plates **fig. 1**:

- 1 Inflation pressure.
- 2 Car marking.
- 3 Chassis marking (VIN).
- 4 Model plate (VIN).

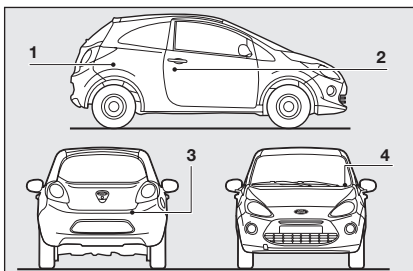

fig. 1

KA00132m

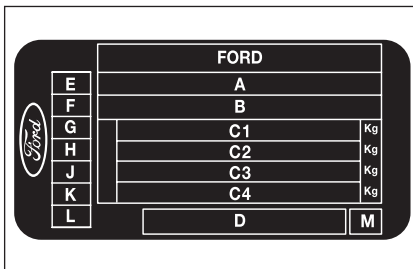

fig. 2

KA00135m

C4 Maximum permitted weight for the rear axle.

M Emission figures (diesel only).

D Bodywork type or model codes.

L Exhaust emission level codes.

K Body paintwork colour codes.

J Interior trim codes.

H Ratio at the gearbox axle codes

G Gearbox codes

F Engine codes

E Driver's side

VEHICLE IDENTIFICATION PLATE **fig. 2**

It is fitted to the right front door pillar and contains the following information:

- A** National or vehicle homologation
- B** VIN plate
- C1** Vehicle gross weight.
- C2** Gross weight with trailer.
- C3** Maximum permitted weight for the front axle.

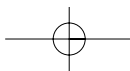

CHASSIS MARKING fig. 3

It bears the following identification data:

- manufacturer identification code
- bodywork type
- factory
- model
- manufacture date: year/month
- vehicle numerical sequence

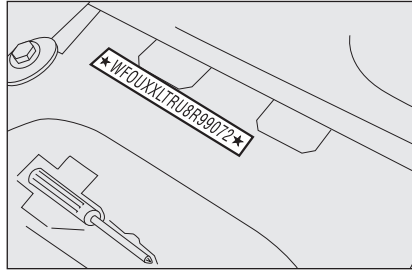

fig. 3

ENGINE MARKING

Engine marking is stamped on the cylinder block and includes the model and the chassis number.

YOUR CAR

SAFETY

STARTING AND
DRIVING

WARNING
LIGHTS AND
MESSAGES

IN AN
EMERGENCY

MAINTENANCE
AND CARE

**TECHNICAL
SPECIFICATIONS**

ALPHABETICAL
INDEX

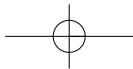

ENGINE CODES - BODYWORK VERSIONS

Versions	Engine type code	Bodywork version code
1.2L Duratec	169A4000	RU8AAAAIU
1.3L Duratorq	169A1000	RU8BAAAAIU

YOUR CAR

SAFETY

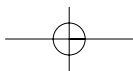
STARTING AND
DRIVINGWARNING
LIGHTS AND
MESSAGESIN AN
EMERGENCYMAINTENANCE
AND CARETECHNICAL
SPECIFICATIONSALPHABETICAL
INDEX

ENGINE

GENERAL INFORMATION		1.2L Duratec	1.3L Duratorq
Engine code		169A4000	169A1000
Cycle		Otto	Diesel
Number and layout of cylinders		4 in line	4 in line
Piston bore and stroke	mm	70.8 x 78.86	69.6 x 82
Total displacement	cm ³	1242	1248
Compression ratio		11.1:1	17.6:1
Maximum power (EEC)	kW HP	51 69	55 75
corresponding ratio	rpm	5500	4000
Maximum torque (EEC)	Nm kgm	102 10.4	145 14.8
corresponding ratio	rpm	3000	1500
Spark plugs		NGK DCPR7E-N-10	-
Fuel		Unleaded petrol 95 R.O.N.	Diesel fuel for motor vehicles (EN590 Specification)

YOUR CAR

SAFETY

STARTING AND
DRIVINGWARNING
LIGHTS AND
MESSAGESIN AN
EMERGENCYMAINTENANCE
AND CARETECHNICAL
SPECIFICATIONSALPHABETICAL
INDEX

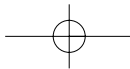

YOUR CAR

SAFETY

STARTING AND
DRIVINGWARNING
LIGHTS AND
MESSAGESIN AN
EMERGENCYMAINTENANCE
AND CARETECHNICAL
SPECIFICATIONSALPHABETICAL
INDEX

FUEL FEED/IGNITION

	1.2L Duratec	1.3L Duratorq
Fuel feed	Multipoint electronic injection sequential phased, returnless system	Direct injection "Common Rail" electronic control with con turbocharged engine and intercooler



WARNING

Modifications or repairs to the fuel feed system that are not carried out properly or do not take the system's technical specifications into account can cause malfunctions leading to the risk of fire.

TRANSMISSION

	1.2L Duratec - 1.3L Duratorq
Gearbox	Five forward gears plus reverse with synchronisers for forward gears
Clutch	Self-adjusting with pedal without idle stroke
Drive	Front

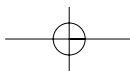

BRAKES

I.2L Duratec - I.3L Duratorq	
Service brakes:	
– front	Disk brakes
– rear	self-centring drum and shoe with a control cylinder for each wheel
Parking brake	controlled by hand lever, acting on rear brakes

IMPORTANT Water, ice and salt sprinkled on the roads may deposit on the brake disks reducing braking efficiency the first time the brakes are engaged.

SUSPENSIONS

I.2L Duratec - I.3L Duratorq	
Front indicators	with Mc Pherson type independent wheels; consisting of a mechanical crosspiece, shock absorbers, helical springs and for the versions with power steering by stabilizer bar.
Rear	with torsion axle and interconnected wheels; consisting of torsion axle and two tubular arms with shock absorbers and helical springs.

STEERING SYSTEM

I.2L Duratec - I.3L Duratorq	
Type	rack and pinion with electric power steering (where provided for)
Turning circle	m 9.3

YOUR CAR

SAFETY

STARTING AND
DRIVINGWARNING
LIGHTS AND
MESSAGESIN AN
EMERGENCYMAINTENANCE
AND CARETECHNICAL
SPECIFICATIONSALPHABETICAL
INDEX

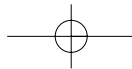

YOUR CAR

SAFETY

STARTING AND
DRIVINGWARNING
LIGHTS AND
MESSAGESIN AN
EMERGENCYMAINTENANCE
AND CARETECHNICAL
SPECIFICATIONSALPHABETICAL
INDEX

WHEELS

RIMS AND TYRES

Pressed steel or alloy rims. Tubeless radial carcass tyres. All approved tyres are listed in the Log Book.

IMPORTANT In the event of discrepancies between the information provided on this “Owner handbook” and the “Log book”, consider the specifications shown in the log book only.

Respect the prescribed size to ensure safety of the car in movement. Fit tyres of the same make and type on all wheels.

IMPORTANT Do not use inner tubes with Tubeless tyres.

SMALL SPARE WHEEL

Pressed steel rim Tubeless tyre.

WHEEL GEOMETRY

Toe-in measured between rims: 1.8 ± 1 mm

The values refer to the car in running order.

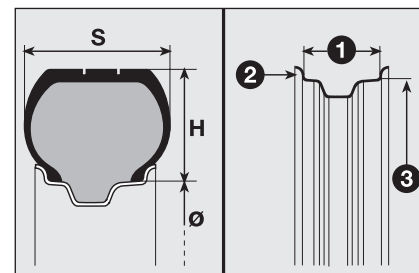

fig. 4

KA00083m

READING TYRE MARKINGS fig. 4

Example: 175/65 R 14 82T

175 = Nominal width (S, distance in mm between sidewalls).

65 = Height/width ratio (H/S) in percentage.

R = Radial tyre.

14 = Rim diameter in inches (Ø).

82 = Load rating (capacity).

T = Maximum speed rating.

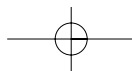

Maximum speed rating**Q** = up to 160 km/h.**R** = up to 170 km/h.**S** = up to 180 km/h.**T** = up to 190 km/h.**U** = up to 200 km/h.**H** = up to 210 km/h.**V** = up to 240 km/h.**Maximum speed rating
for snow tyres****QM + S** = up to 160 km/h.**TM + S** = up to 190 km/h.**HM + S** = up to 210 km/h.**Load rating (capacity)****70** = 335 kg**71** = 345 kg**72** = 355 kg**73** = 365 kg**74** = 375 kg**75** = 387 kg**76** = 400 kg**77** = 412 kg**78** = 425 kg**79** = 437 kg**80** = 450 kg**81** = 462 kg**82** = 475 kg**83** = 487 kg**84** = 500 kg**85** = 515 kg**86** = 530 kg**87** = 545 kg**88** = 560 kg**89** = 580 kg**90** = 600 kg**91** = 615 kg**READING RIM MARKINGS fig. 4****Example: 6J x 15H2****6** = rim width in inches **1**.**J** = rim drop centre outline (side projection where the tyre bead rests) **2**.**15** = rim nominal diameter in inches (corresponds to diameter of the tyre to be mounted) **3** = Ø.**H2** = shape and number of the humps (circumference relief, holding into its seat the bead of the Tubeless tyre on the rim).

YOUR CAR

SAFETY

STARTING AND
DRIVINGWARNING
LIGHTS AND
MESSAGESIN AN
EMERGENCYMAINTENANCE
AND CARETECHNICAL
SPECIFICATIONSALPHABETICAL
INDEX

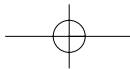

Versions	Rims	Tyres provided	Tyres snow	Spare wheel (where specified)	
				Rim	Tyre
1.2L Duratec	5.5jx14 H2 ET 35	165/65 R14 82T	165/65 R14 82Q	4Bx14 ET 43	135/80 B14 84P
	5.5jx14 H2 ET 35	175/65 R14 82T	175/65 R14 82Q		
	6jx15 H2 ET 40	195/50 R15 82T	195/50 R15 82Q		
	6.5jx16 H2 ET 40	195/45 R16 84T	195/45 R16 84Q		
1.3L Duratorq	5.5jx14 H2 ET 35	165/65 R14 82T	165/65 R14 82Q	4Bx14 ET 43	135/80 B14 84P
	5.5jx14 H2 ET 35	175/65 R14 82T	175/65 R14 82Q		
	6jx15 H2 ET 40	195/50 R15 82T	195/50 R15 82Q		
	6.5jx16 H2 ET 40	195/45 R16 84T	195/45 R16 84Q		

COLD INFLATION PRESSURE (bar)

Add +0.3 bar to the prescribed inflation pressure when the tyres are warm.
Recheck pressure value with cold tyres.

Tyres	Versions	Average load		Full load		Spare wheel (where provided for)
		Front	rear	Front	Rear	
165/65 R14 82T	1.2L Duratec	2.2	2.0	2.3	2.5	2.8
	1.3L Duratorq	2.4	2.0	2.5	2.5	
175/65 R14 82T	1.2L Duratec	2.0	2.0	2.3	2.5	
	1.3L Duratorq	2.2	2.0	2.3	2.5	
195/50 R15 82T	1.2L Duratec	2.0	2.0	2.3	2.5	
	1.3L Duratorq	2.2	2.0	2.3	2.5	
195/45 R16 84T	1.2L Duratec	2.0	2.0	2.3	2.5	
	1.3L Duratorq	2.2	2.0	2.3	2.5	

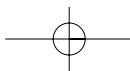

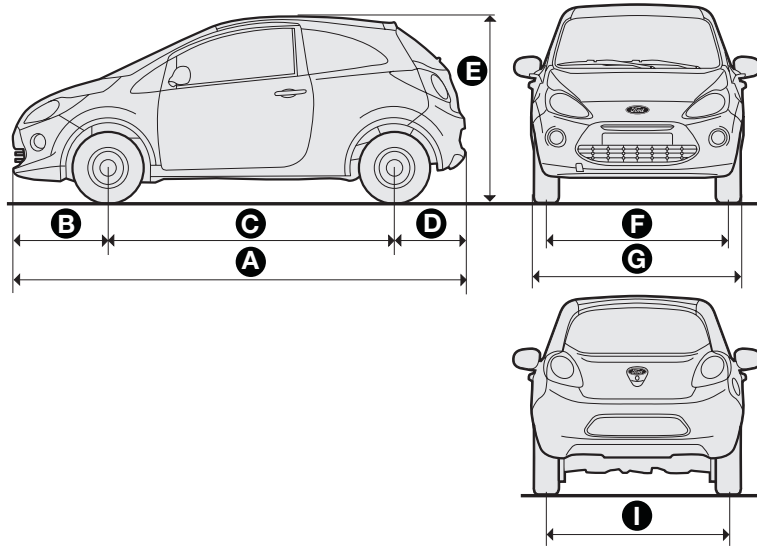

fig. 5

KA00084m

DIMENSIONS

Dimensions are expressed in mm and refer to the vehicle fitted with standard tyres.

The height refers to the vehicle unladen.

Versions	A	B	C	D	E	F	G	I
1.2L Duratec	3620	758	2300	562	1506(*)	1399÷1409 (*)	1658	1387÷1397(*)
1.3L Duratorq	3620	758	2300	562	1506(*)	1399÷1409 (*)	1658	1387÷1397(*)

(*) Track measurements may vary according to rim/tyre size.

YOUR CAR

SAFETY

STARTING AND
DRIVINGWARNING
LIGHTS AND
MESSAGESIN AN
EMERGENCYMAINTENANCE
AND CARETECHNICAL
SPECIFICATIONSALPHABETICAL
INDEX

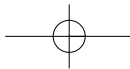

YOUR CAR

SAFETY

STARTING AND
DRIVINGWARNING
LIGHTS AND
MESSAGESIN AN
EMERGENCYMAINTENANCE
AND CARETECHNICAL
SPECIFICATIONSALPHABETICAL
INDEX

PERFORMANCE

Top admitted speed after initial car use in km/h.

1.2L Duratec	160 (short ratios) 159 (long ratios)
1.3L Duratorq	162

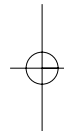
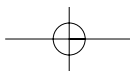

WEIGHTS

Weights (kg)	1.2L Duratec	1.3L Duratorq
Unladen weight (with all fluids, fuel tank filled to 90% and without optional equipment)	865	980
Carrying capacity (*) including the driver:	455	435
Maximum permitted loads (**)		
– front axle:	770	830
– rear axle:	640	640
– total:	1320	1415
Maximum load on roof:	50	50

(*) If special equipment is fitted (sunroof, tow hitch, etc.) the unladen car weight increases, thus reducing the specified payload.

(**) Loads not to be exceeded. The driver is responsible for arranging the loads in the boot and/or in the load compartment so that they comply with the maximum permitted limits.

YOUR CAR

SAFETY

STARTING AND
DRIVINGWARNING
LIGHTS AND
MESSAGESIN AN
EMERGENCYMAINTENANCE
AND CARETECHNICAL
SPECIFICATIONSALPHABETICAL
INDEX

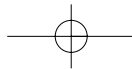

CAPACITIES

		1.2L Duratec	1.3L Duratorq	Prescribed fuels and Original lubricants
Fuel tank: including a reserve of:	litres	35	35 (▲)	Unleaded petrol, at least 95 R.O.N. (▲) Diesel fuel for motor vehicles (EN590 specifications)
	litres	5	5 (▲)	
Engine cooling system:	litres	4.85	6.3	ARTECO Havoline XLC cooling fluid
Engine sump:	litres	2.5	2.5	—
Engine sump and filter:	litres	2.8	2.8	—
Gearbox/differential casing:	litres	1.65	1.65	TUTELA CAR TECHNYX
Hydraulic brake circuit:	kg	0.55	0.55	SUPER DOT 4
Windscreen and rear window washer fluid tank:	litres	2.5	2.5	—

YOUR CAR

SAFETY

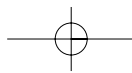
STARTING AND
DRIVINGWARNING
LIGHTS AND
MESSAGESIN AN
EMERGENCYMAINTENANCE
AND CARETECHNICAL
SPECIFICATIONSALPHABETICAL
INDEX

FLUIDS AND LUBRICANTS

RECOMMENDED PRODUCTS AND SPECIFICATIONS

Application	Fluid and lubricant quality characteristics for correct car operation	Interval frequency
Lubricants for petrol and diesel engines	SAE 5W-40 engine oil (WSS-M2C917-A)	According to Scheduled Maintenance Plan

In emergency cases where genuine products are not available, lubricants with min. performance ACEA C3 are accepted. If this is the case, the best engine performance is not guaranteed. We however recommend replacing the lubricant with those recommended by your Ford Dealership.

The use of products with features lower than ACEA C3 could cause engine damage not covered by warranty.

YOUR CAR

SAFETY

STARTING AND
DRIVINGWARNING
LIGHTS AND
MESSAGESIN AN
EMERGENCYMAINTENANCE
AND CARETECHNICAL
SPECIFICATIONSALPHABETICAL
INDEX

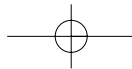

Use	Fluid and lubricant specifications for correct car operation	Genuine fluids and lubricants	Applications
Lubricants and greases for movement transmission	Synthetic lubricant, grade SAE 75W- 85	TUTELA CAR TECHNYX	Manual gearbox and differential
Brake fluid	ESD-M6C57-A Super DOT 4 (BASF Hydraulan 407-I)	SUPER DOT 4	Hydraulic brakes and hydraulic clutch controls
Protective agent for radiators	Protective with antifreeze action	ARTECO Havoline XLC cooling fluid (WSS-M97B44-D)	Cooling circuits

YOUR CAR

SAFETY

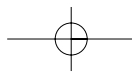
STARTING AND
DRIVINGWARNING
LIGHTS AND
MESSAGESIN AN
EMERGENCYMAINTENANCE
AND CARETECHNICAL
SPECIFICATIONSALPHABETICAL
INDEX

FUEL CONSUMPTION

The fuel consumption figures given in the table below are determined on the basis of the homologation tests set down by specific European Directives.

The procedures below are followed for measuring consumption:

- urban cycle: cold starting followed by driving that simulates urban use of the car;

- extraurban cycle: frequent accelerations in all gears, simulating extraurban use of the car: speed varies between 0 and 120 km/h;
- combined consumption: calculated weighing about 37% of urban cycle consumption and about 63% of extraurban consumption.

IMPORTANT The type of route, traffic situations, weather conditions, driving style, general conditions of the car, trim level/equipment/accessories, load, climate control system, roof rack, other situations that affect air drag may lead to different fuel consumption levels than those measured.

Fuel consumption according to Directive 2004/3/EC (litres x 100 km)

Versions		Urban	Extraurban	Combined
1.2L Duratec	long ratios	6.3	4.4	5.1
	short ratios	6.6	4.5	5.3
1.3L Duratorq		5.2	3.7	4.2

YOUR CAR

SAFETY

STARTING AND
DRIVINGWARNING
LIGHTS AND
MESSAGESIN AN
EMERGENCYMAINTENANCE
AND CARETECHNICAL
SPECIFICATIONSALPHABETICAL
INDEX

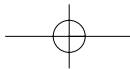

YOUR CAR

SAFETY

STARTING AND
DRIVINGWARNING
LIGHTS AND
MESSAGESIN AN
EMERGENCYMAINTENANCE
AND CARETECHNICAL
SPECIFICATIONSALPHABETICAL
INDEX

CO₂ EMISSIONS

The CO₂ emission levels at the exhaust given in the following tables refer to combined consumption.

Versions

	CO ₂ emissions according to 2004/3/CE Directive (g/km)
1.2L Duratec	119 (long ratios) 125 (short ratios)
1.3L Duratorq	112

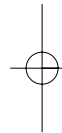
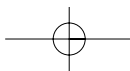

ALPHABETICAL INDEX

A BS	53	– opening	47	Controls	41
Accessories purchased		– closing	47	Coolant gauge	12
by the owner	61	– extending	48	Courtesy lights	40
Air bag	75	Brake fluid level	136	– activation	40
– driver's front airbag	76	Brakes.....	151	– bulb replacement	120
– passenger's front airbag	76	– specifications	151	D ashboard	3
– Side bags-Window bags	77-78	– fluid level	136	Digital display.....	13
Air filter	137	Bulb (when needing to change a)	114	Dimensions	155
ASR.....	56	– general information	114	Dipped beam headlights	37
Automatic climate control system ...	34	– bulb types	115	– activation	37
B attery.....	137	C apacities	158	– bulb replacement	118
– jump starting	102	Car Radio	60	Direction indicators	37
– useful advice	138	Carrying children in safety	69	– activation	37
– inspecting the charge	137	Ceiling lights	40	– front bulb replacement	118
– if the battery is flat	128	– front	40	– side bulb replacement	118
– replacement	137	– boot	40	– rear bulb replacement	119
Bodywork.....	148	Central door locking system	45	Door lock device	45
– version codes	148	Chassis (marking)	147	Door release	45
– warranty	143	Checking fluid levels	132	Doors	45
– maintenance	143	Child seats (compliance for use)	72	E BD system	54
Bonnet	49	Clutch	150	Engine compartment (washing)	144
Boot light	40	CO ₂ emissions	162	Engine coolant fluid level	135
– bulb replacement	121	Code Card	6	Engine oil	
Boot.....	47	Control buttons	41	– specifications	159

YOUR CAR

SAFETY

STARTING AND
DRIVINGWARNING
LIGHTS AND
MESSAGESIN AN
EMERGENCYMAINTENANCE
AND CARETECHNICAL
SPECIFICATIONSALPHABETICAL
INDEX

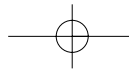

	– fuel consumption	134	Fuel	158	Interiors	144
	– level check	134	– tank capacity	158	Isofix child seat	73
	Engine oil level	134	– fuel consumption	161	J acking the car	129
	Engine	149	– gauge	12	K ey with remote control	6
	– identification code	148	– capacities	158	– ordering additional remote	
	– specifications	149	– fuel cut-off system	42	controls	8
	– marking	147	Fuses (if a fuse blows)	122	– battery replacement	8
	EBD (system)	54	G earbox	85	Key without remote control	6
	EOBD (system)	57	– use of manual gearbox	85	L evels	132
	ESP system	54	– specifications	150	Load limiters	67
	Extending the boot	48	Glass holders	44	M ain beam headlights	37
	External lights	37	H andbrake	84	– activation	37
	F ord CODE (system)	5	Hazard lights	41	– flashing the headlights	37
	Fix & Go (quick repair kit)	110	Head restraints.....	27	– bulb replacement	118
	Flashing the headlights	37	Headlights	51	Maintenance and care	131
	Fluids and lubricants	159	– headlight alignment corrector ...	52	– climate control system	33-36
	Fog lights	41	– light beam orientation	51	Manual climate control system	32
	– control button	41	– orientation of front fog lights ...	52	MSR (system)	56
	– bulb replacement	119	Heating and ventilation	31	MSR system	56
	Follow me home (device)	38	Heating/ventilation system.....	31	Multifunction display	17
	Fuel cap	63	Hill Holder system	55	N umber plate light	120
	Fuel consumption	161	I dentification data	146	O ddment compartment	43
	Fuel cut-off system	42	In an emergency	101	P aint	143
	Fuel feed/ignition	150	Instrument panel	10	Parking	84
	Fuel flap	63	Instruments	10		
	Fuel gauge	12	Interior fittings	43		
	Fuel saving	86				

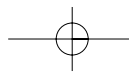

Parking sensor	58	– brushes	141	Starting the engine	82
Passenger compartment air diffusers	30	– sprays	142	– jump starting	102
Performance	156	Rear view mirrors	29	– bump starting	103
Plates	146	– electric	29	– Start-up device	9
– identification data	146	– external	29	– procedure for petrol versions ...	82
– paint and bodywork	146	– internal	29	– procedure for Diesel versions ..	83
Pollen filter	137	Rev counter	12	– how to warm up the engine after it has just started	83
Power windows	46	Reversing light	119	– stopping the engine	84
Pretensioners	67	Rubber hoses	140	Start-up device	9
Protecting the environment	63	S afety	65	Steering	151
Provision for installing "Isofix" child seat	73	Seat adjustment	26	Steering column lock	9
R adio and mobile phone transmitters	61	Seat belts	66	Steering wheel adjustment	28
Radio remote-control	163	– general information	67	Storing the car	89
– ordering additional remote controls	8	– use	66	Sun visors	43
– battery replacement	8	– load limiters	67	Suspension	151
Rear fog lights	42	– maintenance	69	Symbols	5
– control button	42	– pretensioners	67	T ail-gate	47
– bulb replacement	119	Seats	26	Technical data	145
Rear screen washer	38	– cleaning	144	Third brake light	120
– activation	38	Setting off and driving	81	Top speeds	156
– fluid level	135	Sidelights	37	Towing the car	129
Rear screen wiper	39	– bulb replacement	119	Towing trailers	87
– activation	39	Smart washing	38	Transmission	150
		Snow chains	89	Trip Computer	24
		Spark plugs	149	Tyre pressure	154
		Speedometer	12	Tyres	154
		Speedometer	12		

YOUR CAR

SAFETY

STARTING AND
DRIVINGWARNING
LIGHTS AND
MESSAGESIN AN
EMERGENCYMAINTENANCE
AND CARETECHNICAL
SPECIFICATIONSALPHABETICAL
INDEX

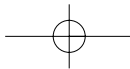

YOUR CAR
SAFETY
STARTING AND DRIVING
WARNING LIGHTS AND MESSAGES
IN AN EMERGENCY
MAINTENANCE AND CARE
TECHNICAL SPECIFICATIONS
ALPHABETICAL INDEX

– standard	154	– brushes	141
– snow tyres	154	– sprays	142
– tyre marking	152	Windscreen/rear screen washer	
– maintenance	139	fluid level	135
– inflation pressure	154		
– replacement	104		
U nder-seat storage compartment ...	43		
Use of manual gearbox	85		
V entilation	31		
W arning lights and messages	91		
Weights	157		
Wheel	152		
– spare wheel	154		
– replacement	104		
Wheel geometry	152		
Wheel replacement	104		
Wheel rims	152		
– reading rim markings	153		
Window cleaning	144		
Windscreen and rear window			
wiper blades	141		
Windscreen washer	38		
– activation	38		
– fluid level	135		
Windscreen wiper	38		
– activation	38		

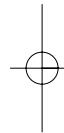
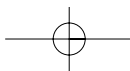

COLD INFLATION PRESSURE (bar)

Add +0.3 bar to the prescribed inflation pressure when the tyres are warm.
Recheck pressure value with cold tyres.

Tyres	Versions	Average load		Full load		Spare wheel (where provided for)
		Front	rear	Front	Rear	
165/65 R14 82T	1.2L Duratec	2.2	2.0	2.3	2.5	2.8
	1.3L Duratorq	2.4	2.0	2.5	2.5	
175/65 R14 82T	1.2L Duratec	2.0	2.0	2.3	2.5	
	1.3L Duratorq	2.2	2.0	2.3	2.5	
195/50 R15 82T	1.2L Duratec	2.0	2.0	2.3	2.5	
	1.3L Duratorq	2.2	2.0	2.3	2.5	
195/45 R16 84T	1.2L Duratec	2.0	2.0	2.3	2.5	
	1.3L Duratorq	2.2	2.0	2.3	2.5	

CHANGING ENGINE OIL (litres)

	1.2L Duratec	1.3L Duratorq
Engine sump	2.5	2.5
Engine sump and filter	2.8	2.8

FUEL CAPACITIES (litres)

	1.2L Duratec	1.3L Duratorq
Tank capacity	35	35
Reserve	5	5

Refuel petrol-driven cars only with unleaded fuel with an octane number (RON) of at least 95 (Specification EN 228)
Refuel diesel-driven cars only with diesel fuel (Specification EN 590)