

FORD **TRANSIT** Owner's Manual



The information contained in this publication was correct at the time of going to print. In the interest of continuous development, we reserve the right to change specifications, design or equipment at any time without notice or obligation. No part of this publication may be reproduced, transmitted, stored in a retrieval system or translated into any language in any form by any means without our written permission. Errors and omissions excepted.

© Ford Motor Company 2013

All rights reserved.

Part Number: CG3612en 12/2013 20131211085629

Table of Contents

Introduction

About This Manual.....	5
Symbols Glossary.....	5
Data Recording.....	7
Replacement Parts Recommendation.....	8
Mobile Communications Equipment.....	8

At a Glance

Front Exterior Overview.....	10
Vehicle Interior Overview.....	11
Instrument Panel Overview - LHD.....	12
Instrument Panel Overview - RHD.....	13

Child Safety

Installing Child Seats.....	15
Child Seat Positioning.....	19
Child Safety Locks.....	23

Safety Belts

Fastening the Safety Belts.....	24
Safety Belt Height Adjustment.....	25
Safety Belt Minder.....	26

Supplementary Restraints System

Principle of Operation.....	27
Driver Airbag.....	27
Passenger Airbag.....	27
Side Airbags.....	29
Side Curtain Airbags.....	29

Keys and Remote Controls

General Information on Radio Frequencies.....	30
Remote Control.....	30
Replacing a Lost Key or Remote Control.....	30

Locks

Locking and Unlocking.....	31
----------------------------	----

Security

Passive Anti-Theft System.....	36
Anti-Theft Alarm.....	36

Power Running Boards

Using Power Running Boards.....	39
---------------------------------	----

Steering Wheel

Adjusting the Steering Wheel.....	41
Audio Control.....	41
Voice Control.....	42
Cruise Control.....	42
Information Display Control.....	43

Wipers and Washers

Windshield Wipers.....	44
Autowipers.....	44
Windshield Washers.....	45
Rear Window Wiper and Washers.....	46

Lighting

General Information.....	47
Lighting Control.....	47
Autolamps.....	48
Instrument Lighting Dimmer.....	49
Headlamp Exit Delay.....	49
Daytime Running Lamps.....	49
Front Fog Lamps.....	50
Rear Fog Lamps.....	50
Headlamp Leveling.....	50
Cornering Lamps.....	51
Direction Indicators.....	51
Stepwell Lamps.....	51
Interior Lamps.....	52

Table of Contents

Windows and Mirrors

Power Windows.....	53
Exterior Mirrors.....	54
Interior Mirror.....	54
Sliding Windows.....	55
Rear Quarter Windows.....	55

Instrument Cluster

Gauges.....	56
Warning Lamps and Indicators.....	57
Audible Warnings and Indicators.....	61

Information Displays

General Information.....	62
Clock.....	67
Trip Computer.....	67
Personalized Settings.....	68
Information Messages.....	68

Climate Control

Principle of Operation.....	73
Air Vents.....	73
Manual Climate Control.....	74
Hints on Controlling the Interior Climate.....	75
Rear Passenger Climate Controls.....	76
Heated Windows and Mirrors.....	77
Auxiliary Heater.....	77

Seats

Sitting in the Correct Position.....	81
Head Restraints.....	81
Manual Seats.....	82
Power Seats.....	84
Rear Seats.....	86
Heated Seats.....	88

Auxiliary Power Points

Auxiliary Power Points.....	89
-----------------------------	----

Cigar Lighter.....	90
--------------------	----

Storage Compartments

Cup Holders.....	91
Overhead Console.....	91
Ashtray.....	91
Bottle Holder.....	91
Under Seat Storage.....	92
Front Door Storage Compartment.....	93

Starting and Stopping the Engine

General Information.....	94
Ignition Switch.....	94
Steering Wheel Lock.....	94
Starting a Diesel Engine.....	95
Diesel Particulate Filter.....	95
Switching Off the Engine.....	96

Unique Driving Characteristics

Auto-Start-Stop.....	97
----------------------	----

Fuel and Refueling

Safety Precautions.....	99
Fuel Quality.....	100
Running Out of Fuel.....	100
Catalytic Converter.....	101
Selective Catalytic Reduction System.....	102
Refueling.....	104
Fuel Consumption.....	106

Transmission

Manual Transmission.....	107
--------------------------	-----

All-Wheel Drive

Using All-Wheel Drive.....	108
----------------------------	-----

Table of Contents

Brakes

General Information.....	109
Hints on Driving With Anti-Lock Brakes.....	109
Parking Brake.....	110
Hill Start Assist.....	111

Traction Control

Principle of Operation.....	112
Using Traction Control.....	112

Stability Control

Principle of Operation.....	113
Using Stability Control.....	113

Parking Aids

Principle of Operation.....	114
Parking Aid.....	114
Rear View Camera.....	116

Cruise Control

Principle of Operation.....	118
Using Cruise Control.....	118
Using Adaptive Cruise Control.....	119

Driving Aids

Speed Limiter.....	124
Driver Alert.....	125
Lane Keeping System.....	127
Eco Mode.....	128

Load Carrying

General Information.....	130
Roof Racks and Load Carriers.....	130
Load Retaining Fixtures.....	130

Towing

Towing a Trailer.....	132
Trailer Sway Control.....	133

Towing Points.....	133
Towing the Vehicle on Four Wheels.....	134

Driving Hints

Breaking-In.....	135
Reduced Engine Performance.....	135
Economical Driving.....	135
Cold Weather Precautions.....	136
Driving Through Water.....	136
Floor Mats.....	136

Roadside Emergencies

Hazard Warning Flashers.....	138
First Aid Kit.....	138
Warning Triangle.....	138
Emergency Exit.....	138
Fuel Shutoff.....	138
Jump Starting the Vehicle.....	138

Fuses

Fuse Box Locations.....	141
Fuse Specification Chart.....	142
Changing a Fuse.....	151

Maintenance

General Information.....	153
Opening and Closing the Hood.....	153
Under Hood Overview - FWD.....	154
Under Hood Overview - AWD/RWD.....	155
Engine Oil Dipstick.....	156
Engine Oil Check.....	156
Engine Coolant Check.....	157
Brake and Clutch Fluid Check.....	157
Power Steering Fluid Check.....	158
Washer Fluid Check.....	158
Draining the Fuel Filter Water Trap.....	158
Changing the 12V Battery.....	159
Checking the Wiper Blades.....	161
Changing the Wiper Blades.....	161

Table of Contents

Removing a Headlamp.....	162
Changing a Bulb.....	163
Bulb Specification Chart.....	168
Technical Specifications - FWD.....	170
Technical Specifications - RWD.....	171
Technical Specifications - AWD.....	172

Vehicle Care

Cleaning the Exterior.....	174
Cleaning the Interior.....	174
Repairing Minor Paint Damage.....	175
Cleaning the Alloy Wheels.....	175

Wheels and Tires

General Information.....	176
Temporary Mobility Kit.....	176
Tire Care.....	179
Using Winter Tires.....	180
Using Snow Chains.....	180
Tire Pressure Monitoring System.....	180
Changing a Road Wheel.....	184
Technical Specifications.....	190

Capacities and Specifications

Vehicle Dimensions.....	195
Towbar Dimensions.....	200
Vehicle Identification Plate.....	204
Vehicle Identification Number.....	206
Fuel Consumption Figures.....	206

Audio System

General Information.....	207
Audio unit.....	208
Audio unit - Vehicles With: AM/FM/ CD.....	217
Audio unit - Vehicles With: SYNC/ Navigation System.....	221
Audio unit - Vehicles With: SYNC/AM/ FM/CD.....	227

Digital Radio.....	232
Audio Input Jack.....	233
USB Port.....	234
Audio Troubleshooting.....	234

SYNC™

General Information.....	235
Using Voice Recognition.....	236
Using SYNC™ With Your Phone.....	239
SYNC™ Applications and Services.....	250
Using SYNC™ With Your Media Player.....	256
SYNC™ Troubleshooting.....	263

Navigation

Navigation.....	271
-----------------	-----

Appendices

Electromagnetic compatibility.....	280
End User License Agreement.....	281

Introduction

ABOUT THIS MANUAL

Thank you for choosing Ford. We recommend that you take some time to get to know your vehicle by reading this manual. The more that you know about it, the greater the safety and pleasure you will get from driving it.

WARNING



Driving while distracted can result in loss of vehicle control, crash and injury. We strongly recommend that you use extreme caution when using any device that may take your focus off the road. Your primary responsibility is the safe operation of your vehicle. We recommend against the use of any handheld device while driving and encourage the use of voice-operated systems when possible. Make sure you are aware of all applicable local laws that may affect the use of electronic devices while driving.

Note: This manual describes product features and options available throughout the range of available models, sometimes even before they are generally available. It may describe options not fitted to your vehicle.

Note: Some of the illustrations in this manual may be used for different models, so may appear different to you on your vehicle. However, the essential information in the illustrations is always correct.

Note: Always use and operate your vehicle in line with all applicable laws and regulations.

Note: Pass on this manual when selling your vehicle. It is an integral part of the vehicle.

This manual may qualify the location of a component as left-hand side or right-hand side. The side is determined when facing forward in the seat.

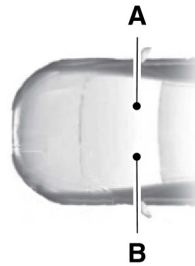

E154903

- A Right-hand side
- B Left-hand side

Protecting the Environment

You must play your part in protecting the environment. Correct vehicle usage and the authorized disposal of waste, cleaning and lubrication materials are significant steps toward this aim.

SYMBOLS GLOSSARY

These are some of the symbols you may see on your vehicle.



Safety alert



See Owner's Manual



Air conditioning system



Anti-lock braking system



Avoid smoking, flames or sparks



Battery

Introduction



Battery acid



Explosive gas



Brake fluid - non petroleum based



Fan warning



Brake system



Fasten safety belt



Cabin air filter



Front airbag



Check fuel cap



Front fog lamps



Child safety door lock or unlock



Fuel pump reset



Child seat lower anchor



Fuse compartment



Child seat tether anchor



Hazard warning flashers



Cruise control



Heated rear window



Do not open when hot



Heated windshield



Engine air filter



Interior luggage compartment release



Engine coolant



Jack



Engine coolant temperature



Keep out of reach of children



Engine oil



Lighting control



Low tire pressure warning

Introduction



Maintain correct fluid level



Note operating instructions



Panic alarm



Parking aid



Parking brake



Power steering fluid



Power windows front/rear



Power window lockout



Service engine soon



Side airbag



Shield the eyes



Stability control



Windshield wash and wipe

DATA RECORDING

A large number of electronic components of your vehicle contain data storage modules temporarily or permanently storing technical data about the condition of the vehicle, events and errors.

In general, this technical information documents the condition of parts, modules, systems or the environment:

- Operating conditions of system components (e.g. filling levels).
- Status messages of the vehicle and its individual components (e.g. number of wheel revolutions/rotational speed, deceleration, lateral acceleration).
- Malfunction and defects in important system components (e.g. lighting and brake system).
- Vehicle reactions in particular driving situations (e.g. inflation of an airbag, activation of the stability regulation system).
- Environmental conditions (e.g. temperature).

These data are exclusively technical and help identification and correction of errors as well as optimisation of vehicle functions. Motion profiles indicating travelled routes cannot be created with these data.

If services are used (e.g. repair works, service processes, warranty cases, quality assurance), employees of the service network (including manufacturers) are able to read out this technical information from the event and error data storage modules using special diagnostic devices. If required, you will receive further information. After an error has been corrected, these data are deleted from the error storage module or they are constantly overwritten.

Introduction

When using the vehicle, situations may occur in which these technical data related to other information (accident report, damages on the vehicle, witness statements etc.) may be associated with a specific person - possibly, with the assistance of an expert.

Additional functions contractually agreed upon with the client (e.g. vehicle location in emergency cases) allow the transmission of particular vehicle data from the vehicle.

REPLACEMENT PARTS RECOMMENDATION

Your vehicle has been built to the highest standards using quality parts. We recommend that you demand the use of genuine Ford and Motorcraft parts whenever your vehicle requires scheduled maintenance or repair. You can clearly identify genuine Ford and Motorcraft parts by looking for the Ford, FoMoCo or Motorcraft branding on the parts or their packaging.

Scheduled Maintenance and Mechanical Repairs

One of the best ways for you to make sure that your vehicle provides years of service is to have it maintained in line with our recommendations using parts that conform to the specifications detailed in this Owner's Manual. Genuine Ford and Motorcraft parts meet or exceed these specifications.

Collision Repairs

We hope that you never experience a collision, but accidents do happen. Genuine Ford replacement collision parts meet our stringent requirements for fit, finish, structural integrity, corrosion protection and dent resistance. During vehicle

development we validate these parts deliver the intended level of protection as a whole system. A great way to know for sure you are getting this level of protection is to use genuine Ford replacement collision parts.

Warranty on Replacement Parts

Genuine Ford and Motorcraft replacement parts are the only replacement parts that benefit from a Ford Warranty. Damage caused to your vehicle as a result of the failure of non-Ford parts may not be covered by the Ford Warranty. For additional information, refer to the terms and conditions of the Ford Warranty.

MOBILE COMMUNICATIONS EQUIPMENT

Using mobile communications equipment is becoming increasingly important in the conduct of business and personal affairs. However, you must not compromise your own or others' safety when using such equipment. Mobile communications can enhance personal safety and security when appropriately used, particularly in emergency situations. Safety must be paramount when using mobile communications equipment to avoid negating these benefits. Mobile communication equipment includes, but is not limited to, cellular phones, pagers, portable email devices, text messaging devices and portable two-way radios.

Introduction

WARNING



Driving while distracted can result in loss of vehicle control, crash and injury. We strongly recommend that you use extreme caution when using any device that may take your focus off the road. Your primary responsibility is the safe operation of your vehicle. We recommend against the use of any hand-held device while driving and encourage the use of voice-operated systems when possible. Make sure you are aware of all applicable local laws that may affect the use of electronic devices while driving.

At a Glance

FRONT EXTERIOR OVERVIEW

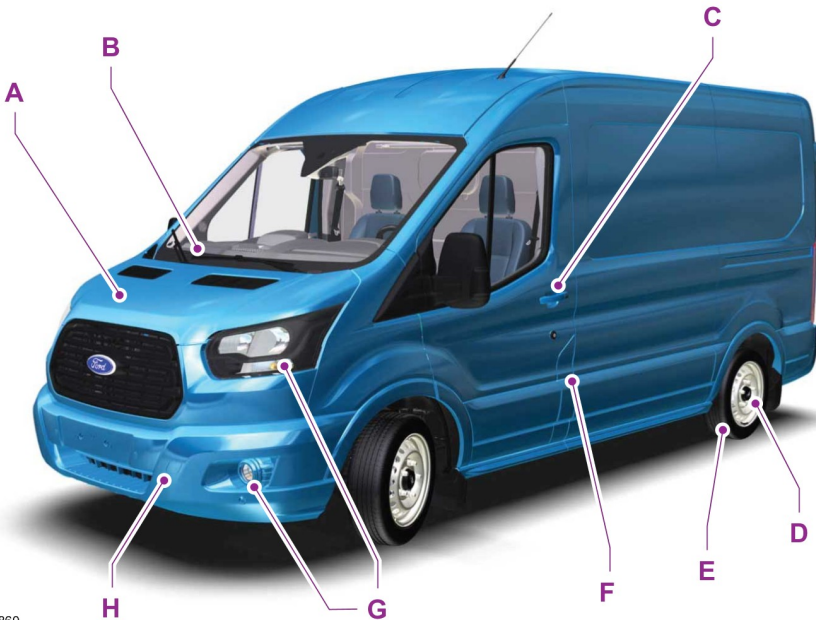

E170860

- A See **Maintenance** (page 153).
- B See **Changing the Wiper Blades** (page 161).
- C See **Locking and Unlocking** (page 31).
- D See **Wheels and Tires** (page 176).
- E See **Technical Specifications** (page 190).
- F See **Refueling** (page 104). See **Selective Catalytic Reduction System** (page 102).
- G See **Changing a Bulb** (page 163).
- H See **Towing Points** (page 133).

At a Glance

VEHICLE INTERIOR OVERVIEW

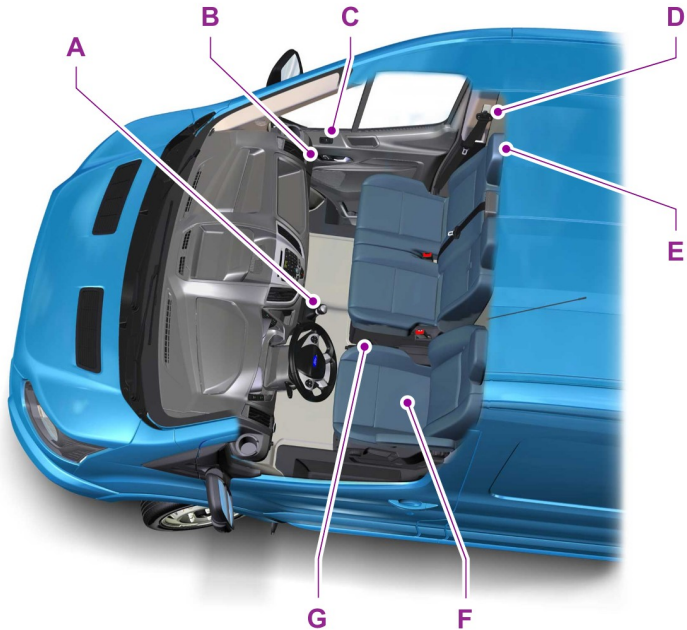

E170861

- A See **Manual Transmission** (page 107).
- B See **Locking and Unlocking** (page 31).
- C See **Power Windows** (page 53).
- D See **Fastening the Safety Belts** (page 24).
- E See **Head Restraints** (page 81).
- F See **Manual Seats** (page 82).
- G See **Parking Brake** (page 110). See **Hill Start Assist** (page 111).

At a Glance

INSTRUMENT PANEL OVERVIEW - LHD

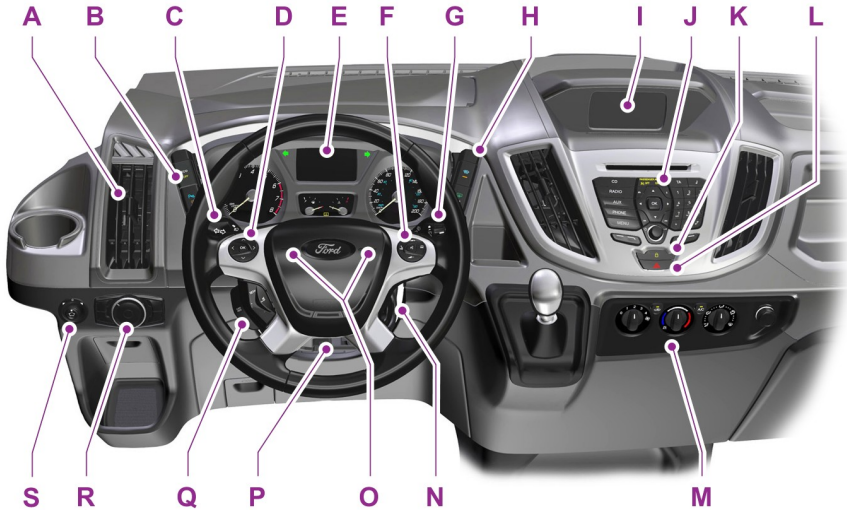

E170862

- A See **Air Vents** (page 73).
- B See **Auto-Start-Stop** (page 97). See **Parking Aid** (page 114).
- C See **Direction Indicators** (page 51). See **Lighting Control** (page 47).
- D See **Information Displays** (page 62).
- E See **Instrument Cluster** (page 56).
- F See **Audio Control** (page 41). See **Voice Control** (page 42).
- G See **Wipers and Washers** (page 44).
- H See **Heated Windows and Mirrors** (page 77).
- I Information and entertainment display.
- J See **Audio System** (page 207).
- K See **Locking and Unlocking** (page 31).
- L See **Hazard Warning Flashers** (page 138).
- M See **Climate Control** (page 73).

At a Glance

- N See **Ignition Switch** (page 94).
- O Horn
- P See **Adjusting the Steering Wheel** (page 41).
- Q See **Cruise Control** (page 118).
- R See **Lighting** (page 47).
- S See **Exterior Mirrors** (page 54).

INSTRUMENT PANEL OVERVIEW - RHD

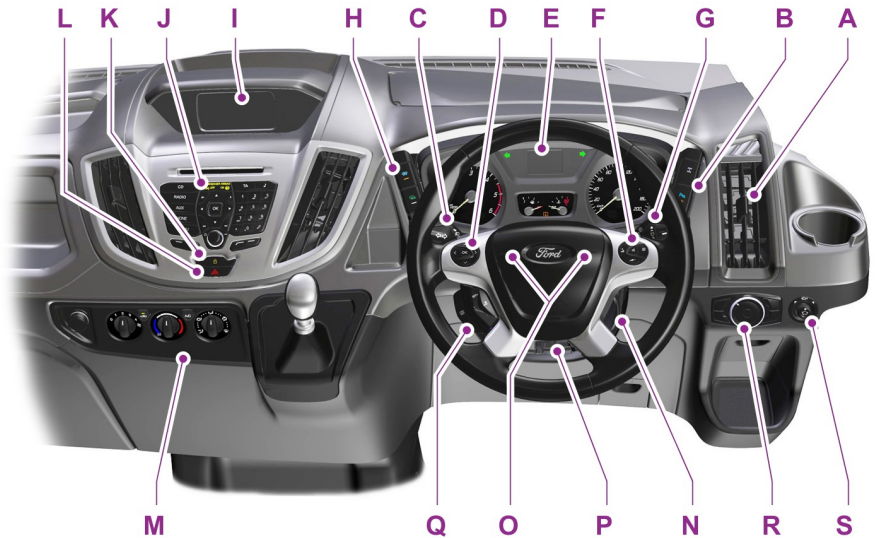

E170863

- A See **Air Vents** (page 73).
- B See **Auto-Start-Stop** (page 97). See **Parking Aid** (page 114).
- C See **Direction Indicators** (page 51). See **Lighting Control** (page 47).
- D See **Information Displays** (page 62).
- E See **Instrument Cluster** (page 56).

At a Glance

- F See **Audio Control** (page 41). See **Voice Control** (page 42).
- G See **Wipers and Washers** (page 44).
- H See **Heated Windows and Mirrors** (page 77).
- I Information and entertainment display.
- J See **Audio System** (page 207).
- K See **Locking and Unlocking** (page 31).
- L See **Hazard Warning Flashers** (page 138).
- M See **Climate Control** (page 73).
- N See **Ignition Switch** (page 94).
- O Horn
- P See **Adjusting the Steering Wheel** (page 41).
- Q See **Cruise Control** (page 118).
- R See **Lighting** (page 47).
- S See **Exterior Mirrors** (page 54).

Child Safety

INSTALLING CHILD SEATS



E161855



E133140





E68916

WARNINGS

 Extreme Hazard! Never use a rearward facing child restraint on a seat protected by an active airbag in front of it. Death or serious injury to the child can occur.

WARNINGS

 Your vehicle is equipped with a passenger airbag deactivation switch. See **Passenger Airbag** (page 27). You must switch the airbag off when using a rearward facing child seat on the front seat. Make sure you switch the airbag back on following removal of the rearward facing child seat.

 Use an approved child seat to secure children less than 60 in (150 cm) tall on the rear seat.

 Read and follow the manufacturer's instructions when you are installing a child seat.

 Do not modify child seats in any way.

 Do not hold a child on your lap when your vehicle is moving.

 Do not leave unattended children in your vehicle.

 If your vehicle has been involved in a crash, have the child seats checked by an authorized dealer.

Only child seats certified to ECE-R44.03 (or later) have been tested and approved for use in your vehicle. A choice of these are available from an authorized dealer.

Note: *Mandatory use of child seats varies from country to country.*

Child Seats for Different Mass Groups

Use the correct child seat as follows:

Child Safety

Rearward Facing Baby Safety Seat



E68918

Secure children that weigh less than 29 lb (13 kg) in a rearward facing baby safety seat (Group 0+) on the rear seat.

Child Safety Seat



E68920

Secure children that weigh between 29 lb (13 kg) and 40 lb (18 kg) in a child safety seat (Group 1) on the rear seat.

Booster Seats

WARNINGS

-  Do not install a booster seat or a booster cushion with only the lap strap of the safety belt.
-  Do not install a booster seat or a booster cushion with a safety belt that is slack or twisted.
-  Do not put the safety belt under your child's arm or behind their back.
-  Do not use pillows, books or towels to boost your child's height.
-  Make sure that your children sit in an upright position.
-  When using a child seat on a rear seat, the child seat must rest tightly against the vehicle seat. It must not touch the head restraint. If necessary remove the head restraint. See **Head Restraints** (page 81).
-  You must reinstall the head restraint following the removal of the child seat. See **Head Restraints** (page 81).

Secure children that weigh more than 33 lb (15 kg) but are less than 60 in (150 cm) tall in a booster seat or a booster cushion.

Child Safety

Booster Seat (Group 2)



E70710

We recommend that you use a booster seat that combines a cushion with a backrest instead of a booster cushion only. The raised seating position will allow you to position the shoulder strap of the adult safety belt over the center of your child's shoulder and the lap strap tightly across their hips.

Booster Cushion (Group 3)



E68924

ISOFIX Anchor Points

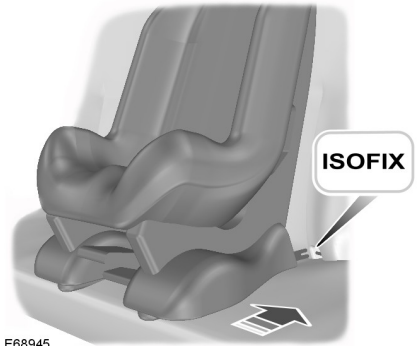

E68945

WARNING

 Use an anti-rotation device when using the ISOFIX system. We recommend the use of a top tether or support leg.

Your vehicle has ISOFIX anchor points that accommodate universally approved ISOFIX child seats.

The ISOFIX system has two rigid attachment arms on the child seat that attach to anchor points on the second row seats, where the cushion and backrest meet. Tether anchor points are fitted to the underside or rear of the second row seats for child seats with a top tether.

Note: When you are purchasing an ISOFIX seat, make sure that you know the correct mass group and ISOFIX size class for the intended seating locations. See **Child Seat Positioning** (page 19).

Child Safety

Attaching a Child Seat with Top Tethers

WARNING



Do not attach the top tether strap to anything other than the correct top tether strap anchor point.

Follow the child seat manufacturer's instructions for installing a child seat with a top tether.

Type 1

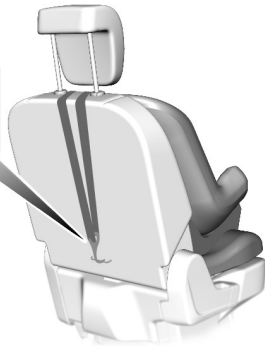

E147062

Type 2



E153270

Attaching a Child Seat with a Support Leg

WARNINGS



Make sure the support leg is long enough to reach the vehicle floor.



Make sure that the child seat manufacturer lists your vehicle as suitable for use with this type of child seat.

Follow the child seat manufacturer's instructions for installing a child seat with a support leg.

Child Safety



E162148

CHILD SEAT POSITIONING

WARNINGS



See an authorized dealer for the latest details relating to our recommended child seats.

WARNINGS



Extreme Hazard! Do not use a rearward facing child seat on a seat protected by an air bag in front of it!



When using a child seat with a support leg, the support leg must rest securely on the floor.



You must reinstall the head restraint following the removal of the child seat. See **Head Restraints** (page 81).



When using a child seat with a safety belt, make sure that the safety belt is not slack or twisted.



Make sure the child seat rests tightly against the vehicle seat. If necessary, adjust the seatback to an upright position. Failure to follow this warning could result in serious personal injury or death.

Note: When using a child seat on a front seat, always adjust the front passenger seat to its fully rearward position. If it proves difficult to tighten the lap section of the safety belt without slack remaining, adjust the seatback to the fully upright position and raise the height of the seat. See **Seats** (page 81).

Child Safety

Seating positions	Mass group categories				
	0	0+	1	2	3
	Up to lb (kg) 22 lb (10 kg)	Up to lb (kg) 29 lb (13 kg)	Range lb (kg) 20–40 lb (9–18 kg)	Range lb (kg) 33–55 lb (15–25kg)	Range lb (kg) 49–79 lb (22–36kg)
Front passenger seat with airbag ON	X	X	UF ¹	UF ¹	UF ¹
Front passenger seat with airbag OFF	U ¹	U ¹	U ¹	U ¹	U ¹
Rear seats - second row, center position - bus	U	U	U	U	U
Rear seats - second row, outboard positions and third row to sixth row - bus	L	L	L	L	L
Rear seats - second row - double cab in van	L	L	L	L	L
Rear seats - second row - double chassis cab	L	L	L	L	L

Child Safety

Seating positions	Mass group categories				
	0	0+	1	2	3
	Up to lb (kg) 22 lb (10 kg)	Up to lb (kg) 29 lb (13 kg)	Range lb (kg) 20–40 lb (9–18 kg)	Range lb (kg) 33–55 lb (15–25kg)	Range lb (kg) 49–79 lb (22–36kg)
Rear seats - second row - kombi	L	L	L	L	L
Rear seats - third row - kombi	L	L	L	L	L

L Suitable only for the following child seats:

- Group 0 and 0+ Britax Baby-safe plus (E1-04301146).
- Group 1 Maxi-Cosi priori XP (E1-04301153).
- Group 2 and 3 Britax kid (E1-04301148).

U Suitable for universal category child seats approved for use in this mass group.

U* Suitable for universal category child seats approved for use in this mass group. However, we recommend that you secure children in a government approved child seat, on the rear seat.

UF* Suitable for universal category forward facing child restraint systems. However, we recommend that you secure children in a government approved child seat, on the rear seat.

X Not suitable for children in this mass group.

Child Safety

ISOFIX Child Seats

Seating positions		Mass group categories		
		0	0+	1
		Up to lb (kg)	Up to lb (kg)	Range lb (kg)
		22 lb (10 kg)	29 lb (13 kg)	20–40 lb (9–18 kg)
		Baby safety seat		Child safety seat
Rear ISOFIX - second row - bus	Size type	IU	IU	IU
	Size class	E	D, E	A, B, B1, D
Rear ISOFIX - second row - double cab in van	Size type	IU	IU	IU
	Size class	E	C, D, E	A, B, B1, C, D
Rear ISOFIX - second row - double chassis cab	Size type	X	X	IU
	Size class			A, B, B1
Rear ISOFIX - second row - kombi	Size type	IU	IU	IU
	Size class	E	D, E	A, B, B1, D

IU Suitable for universal category ISOFIX child seats approved for use in this mass group.

Note: When you are purchasing an ISOFIX child seat, make sure that you know the correct mass group and ISOFIX size class for the intended seating locations.

Child Safety

CHILD SAFETY LOCKS

WARNING



You cannot open the doors from inside if you have put the child safety locks on.

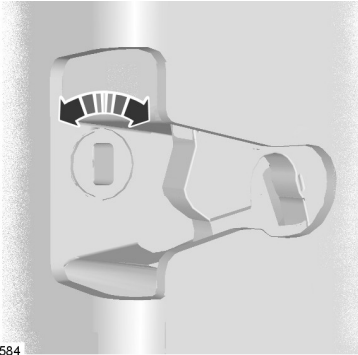

E74584

The childproof locks are located on the rear edge of each rear door and must be set separately for each door.

Left-Hand Side

Turn counterclockwise to lock and clockwise to unlock.

Right-Hand Side

Turn clockwise to lock and counterclockwise to unlock.

Safety Belts

FASTENING THE SAFETY BELTS

WARNINGS

 Insert the tongue into the buckle until you hear a distinct click. You have not fastened the safety belt correctly if you do not hear a distinct click.

 Make sure that your safety belt is securely stored away and is not outside your vehicle when closing the door.



E68586

Pull the safety belt out steadily. It may lock if you pull it sharply or if your vehicle is on a slope.

Press the red button on the buckle to release the safety belt. Hold the tongue and let it retract completely and smoothly to its stowed position.

Using Safety Belts During Pregnancy

WARNING

 Position the safety belt correctly for your safety and that of your unborn child. Do not use only the lap strap or the shoulder strap.



E68584



E68585

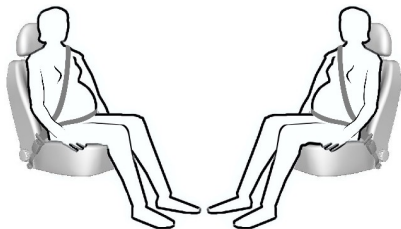

E68587

Safety Belts

Pregnant women should always wear their safety belt. The lap belt portion of a combination lap and shoulder safety belt should be positioned low across the hips below the belly and worn as tight as comfort will allow. The shoulder belt should be positioned to cross the middle of the shoulder and the center of the chest.

SAFETY BELT HEIGHT ADJUSTMENT

WARNING

 Position the safety belt height adjuster so that the belt rests across the middle of your shoulder. Failure to adjust the safety belt correctly could reduce the effectiveness of the safety belt and increase the risk of injury in a collision.

Front Safety Belt

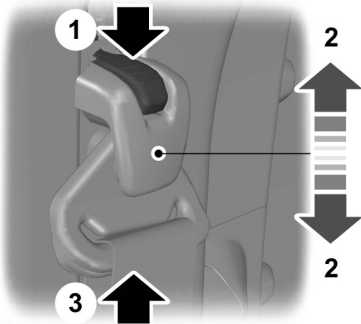

E143981

1. Support the safety belt loop while pressing the adjuster button.
2. Slide the adjuster to the desired position then release the button.
3. Pull down on the safety belt loop to make sure it is secure in position.

Rear Safety Belt

WARNING

 The occupant must make sure that the slider is above the line.

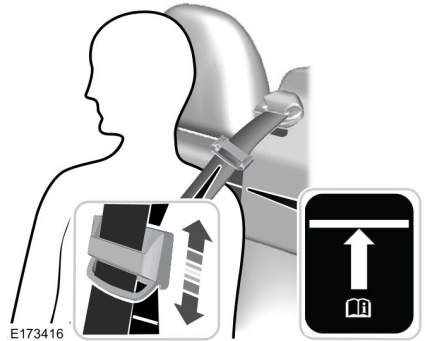

E173416

Adjust the lower edge of the slider so that it is above the white line.

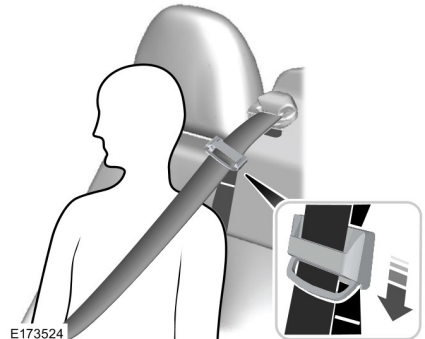

E173524

If, when sitting upright, your shoulder is below the white line, you can adjust the slider to a position below the line so that the belt rests across the middle of your shoulder.

Safety Belts

SAFETY BELT MINDER

WARNING



The system will only provide protection when you use the safety belt correctly.

The warning lamp illuminates and an audible warning will sound when the following conditions have been met:

- The driver's safety belt has not been fastened.
- Your vehicle exceeds a relatively low speed.

It will also illuminate when the driver's safety belt is unfastened when your vehicle is moving.

If you do not fasten the driver's safety belt both the audible and visual warnings will switch off automatically after approximately five minutes.

Turning the Safety Belt Minder Off

See an authorized dealer.

Supplementary Restraints System

PRINCIPLE OF OPERATION

WARNINGS

 Extreme Hazard! Do not use a rearward facing child restraint on a seat protected by an airbag in front of it!

 Do not modify the front of your vehicle in any way. This could adversely affect deployment of the airbags.

 Wear a safety belt and keep sufficient distance between yourself and the steering wheel. Only when you use the safety belt properly, can it hold you in a position that allows the airbag to achieve its optimum effect. See **Sitting in the Correct Position** (page 81).

 Repairs to the steering wheel, steering column, seats, airbags and safety belts must be carried out by an authorized dealer.

 Keep the areas in front of the airbags free from obstruction. Do not affix anything to or over the airbag covers.

 Do not puncture the seat with sharp objects. This could damage and adversely affect deployment of the airbags.

 Use seat covers designed for seats with side airbags. Have these fitted by an authorized dealer.

Note: You will hear a loud bang and see a cloud of harmless powdery residue if an airbag deploys. This is normal.

Note: The front passenger airbag protects both positions of a double seat.

Note: Only wipe airbag covers with a damp cloth.

DRIVER AIRBAG

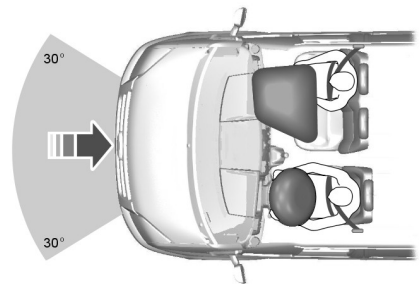

E68581

The airbag will deploy during significant frontal collisions or collisions that are up to 30 degrees from the left or the right. The airbag will inflate within a few thousandths of a second and deflate on contact with the occupant, thus cushioning forward body movement. During minor frontal collisions, overturns, rear collisions and side collisions, the airbag will not deploy.

PASSENGER AIRBAG

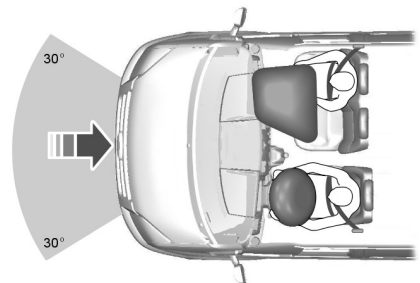

E68581

Supplementary Restraints System

The airbag will deploy during significant frontal collisions or collisions that are up to 30 degrees from the left or the right. The airbag will inflate within a few thousandths of a second and deflate on contact with the occupant, thus cushioning forward body movement. During minor frontal collisions, overturns, rear collisions and side collisions, the airbag will not deploy.

Switching the Passenger Airbag Off

WARNING



You must switch the airbag off when using a rearward facing child seat on the front seat.

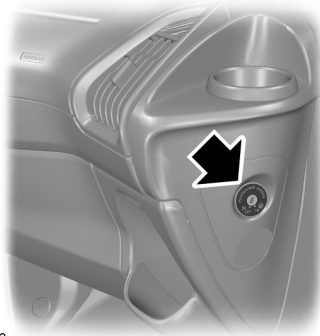

E144003



E71313

The key switch and the airbag deactivation warning lamp are located in the instrument panel.

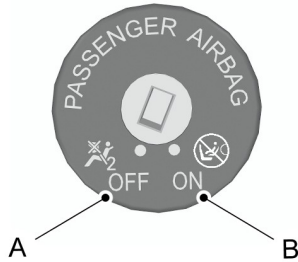

E144007

- A Switch off
- B Switch on

Turn the switch to position A.

When you switch the ignition on, check that the airbag deactivation warning lamp illuminates.

Switching the Passenger Airbag On

WARNING



You must switch the airbag on when you are not using a child seat on the front seat.

Supplementary Restraints System

Turn the switch to position B.

SIDE AIRBAGS

WARNING



Use seat covers designed for seats with side airbags. Have these fitted by an authorized dealer.



E72658

The airbags are located inside the seatback of the front seats. There is a label attached to the side of the seatback to indicate this.

The airbag will deploy during significant lateral collisions. The airbag will not deploy in minor lateral and frontal collisions, rear collisions, or overturns.

SIDE CURTAIN AIRBAGS

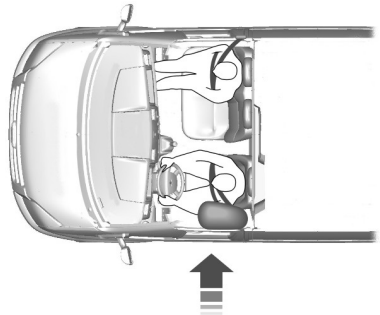

E68905

The airbags are located over the front side windows. There are molded badges in the headlining above the windows to indicate this.

The airbag will deploy during significant lateral collisions. It will also deploy during significant frontal angled collisions. The curtain airbag will not deploy in minor lateral and frontal collisions, rear collisions or overturns.

Keys and Remote Controls

GENERAL INFORMATION ON RADIO FREQUENCIES

Note: *Changes or modifications not expressly approved by the party responsible for compliance could void the user's authority to operate the equipment.*

The typical operating range for your transmitter is approximately 33 ft (10 m).

A decrease in operating range could be caused by:

- weather conditions
- nearby radio towers
- structures around your vehicle
- other vehicles parked next to your vehicle.

The radio frequency used by your remote control can also be used by other short distance radio transmissions (e.g. amateur radios, medical equipment, wireless headphones, remote controls and alarm systems). If the frequencies are jammed, you will not be able to use your remote control. You can lock and unlock the doors with the key.

Note: *Make sure your vehicle is locked before leaving it unattended.*

Note: *If you are in range, the remote control will operate if you press any button unintentionally.*

REMOTE CONTROL

You can program a maximum of eight remote controls to your vehicle. See an authorized dealer.

REPLACING A LOST KEY OR REMOTE CONTROL

You can purchase replacement keys or remote controls from an authorized dealer. Authorized dealers can program remote controls for your vehicle. See **Remote Control** (page 30).

To re-program the passive anti-theft system see an authorized dealer.

Locks

LOCKING AND UNLOCKING

Note: Make sure you have locked your vehicle before leaving it unattended.

Note: Do not leave the keys in your vehicle.

Locking

Locking With the Key

Turn the top of the key toward the front of your vehicle.

Locking With the Remote Control



Press the button.

Note: You can lock the driver door with the key. Use the key when the remote control is not functioning.

Double Locking

WARNING



Do not use double locking when passengers or animals are inside your vehicle. The doors cannot be unlocked from the inside if they have been double locked.

Double locking is a theft protection feature that prevents someone from opening the doors from the inside.

Note: If you double lock your vehicle while inside, switch the ignition on to return the door locks to a single locked state.

Double Locking With the Key

Turn the key to the lock position twice within three seconds.

Double Locking With the Remote Control



Press the button twice within three seconds.

Unlocking

Unlocking With the Key

Turn the top of the key toward the rear of your vehicle.

Unlocking With the Remote Control



Press the button.

Note: You can unlock the driver door with the key. Use the key when the remote control is not functioning.

Note: When you leave your vehicle unattended for several weeks, the remote control will switch off. Your vehicle must be unlocked and the engine started using the key. Unlocking and starting your vehicle once will enable the remote control.

Reprogramming the Unlocking Function

You can reprogram the unlocking function so that only the driver door is unlocked. See **Remote Control** (page 30).

Locking and Unlocking Confirmation

When you lock the doors, the direction indicators will flash twice.

When you unlock the doors, the direction indicators will flash once.

Note: If your vehicle has double locking, the direction indicators will only flash when your vehicle has been double locked.

Locks

Locking and Unlocking the Doors From Inside

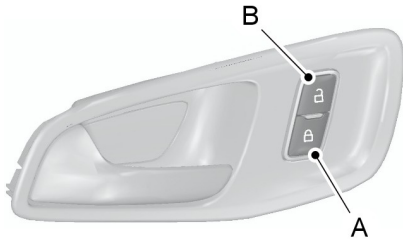

E148829

- A Lock
- B Unlock

You can see the door lock status in the instrument panel. The lamp will illuminate when you lock your vehicle.

Opening and Closing the Sliding Door

Opening the Sliding Door

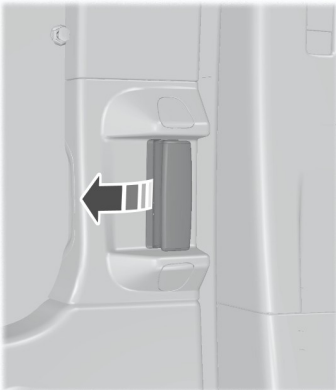

E148804

Pull the interior door handle to open the door.

Closing the Sliding Door

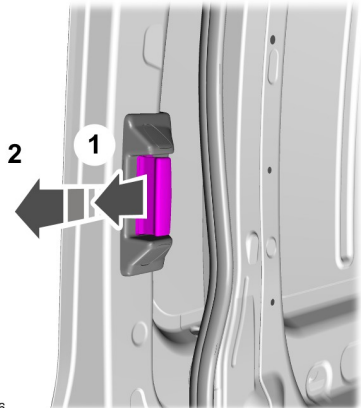

E171966

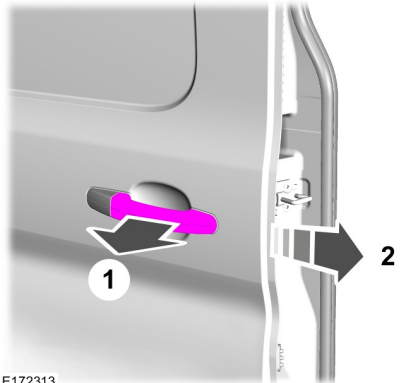

E172313

1. Pull the door handle to release the door check feature.
2. Slide the door to close.

Locks

Opening the Double Rear Doors



E148805

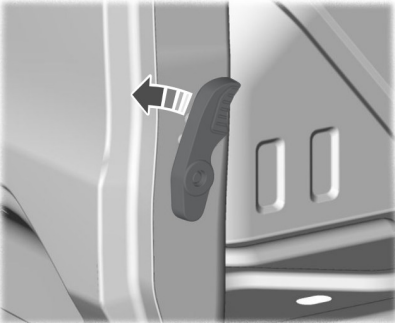

E148806

Slam Locking

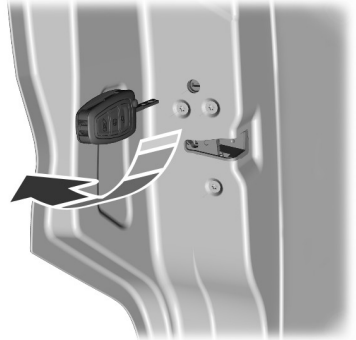

E171967

When there is no power to your vehicle, slam locking allows you to lock a door automatically when you close it. You can manually lock the front passenger door, sliding doors and rear cargo door using the key.

Note: Do not leave the keys in your vehicle.

Note: The horn may sound if you try to lock the doors when a door is still open.

Automatic Locking

Your vehicle has the capability for the doors to lock automatically when you exceed 5 mph (8 km/h). You can switch this function on using the information display. See **Information Displays** (page 62). If you have switched this function on, either use the interior door unlock button or switch the ignition off and use the key or remote control to unlock the rear or sliding door.

Automatic Re-Locking

The doors will re-lock automatically if you do not open a door within 45 seconds of unlocking your vehicle with the remote control. The door locks and the alarm will return to their previous state.

Locks

Automatic Unlocking

You can switch this function on using the information display. See **Information Displays** (page 62). If you have switched this function on, the automatic unlocking feature will unlock all doors within 10 minutes of the end of a drive cycle, when the driver door is opened and the ignition is off.

One-Stage Unlocking

You can switch this function on using the information display. See **Information Displays** (page 62).

If you have switched this function on, you will unlock all doors including the rear doors and the sliding door.

Note: *When you unlock the doors, the direction indicators will flash once.*

You will unlock all of the doors when you:

- Pull either interior handle (except if you have double locked the doors).
- Turn the key in the driver door lock.
- Press the unlock button on the remote control once.
- Press the interior unlock button once.

Note: *When you have double locked your vehicle, the interior unlock button will only work for a period of 20 seconds.*

Two-Stage Unlocking

Note: *When you unlock the doors, the direction indicators will flash once.*

You will unlock the front doors when you:

- Pull either interior handle (except if you have double locked the doors).
- Turn the key in the driver door lock.
- Press the unlock button on the remote control once.
- Press the interior unlock button once.

Note: *When you have double locked your vehicle, the interior unlock button will only work for a period of 20 seconds.*

You will unlock the front doors and cargo area when you:

- Turn the key in the driver door lock to the unlock position twice within three seconds.
- Press the unlock button on the remote control twice within three seconds.
- Press the interior unlock button twice within three seconds.

Note: *When you have double locked your vehicle, the interior unlock button will only work for a period of 20 seconds.*

Zone Re-Locking

If you enable zone re-locking and open one door, this will cause all other doors to remain locked. See an authorized dealer for further information.

The locks on Van, Bus and Kombi have two zones, cabin and cargo. For van and kombi vehicles, the cargo area comprises of the rear doors and the sliding door. For Bus vehicles, the cargo area comprises of the rear doors.

- Exit your vehicle and press the lock button.
- Press the unlock button or the cargo area unlock button once to open the respective zone.

If you now open a door within the unlocked zone, the other doors in that zone will automatically lock.

Locks

Configurable Unlocking

Configurable unlocking is set at the time of vehicle purchase. It allows you to select which doors unlock when you press the unlock button or the cargo area unlock button on your remote control once or twice. You cannot switch this feature back on if you have had it switched off. See an authorized dealer for further information.

Rear Emergency Exit

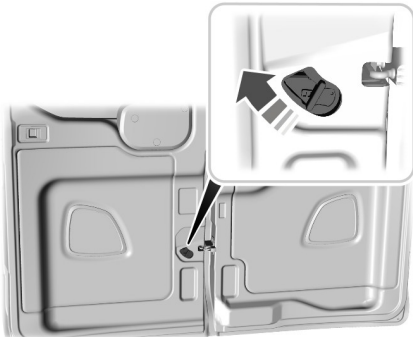

E171968

Pull the interior handle up to open the door in an emergency.

Security

PASSIVE ANTI-THEFT SYSTEM

Principle of Operation

The system prevents someone from starting the engine with an incorrectly coded key.

Note: *Do not leave correctly coded keys in the vehicle. Always take your keys and lock all doors when leaving the vehicle.*

Coded Keys

If you lose a key, you can obtain a replacement from an authorized dealer. If possible, provide them with the key number from the tag provided with the original keys. You can also obtain extra keys from an authorized dealer.

Note: *Have all of your remaining keys erased and recoded if you lose a key. Have replacement keys coded together with recoding your remaining keys. See an authorized dealer for further information.*

Note: *Do not shield your keys with metal objects. This may prevent the receiver from recognizing a coded key.*

Arming the Engine Immobilizer

When you switch the ignition off the engine immobilizer will arm automatically after a short time.

Disarming the Engine Immobilizer

When you switch the ignition on the engine immobilizer will disarm automatically if a correctly coded key is used.

If you are unable to start the engine with a correctly coded key, have your vehicle checked by an authorized dealer.

ANTI-THEFT ALARM

Alarm System

Your vehicle may have one of the following alarm systems:

- Category one alarm with interior sensors and battery back-up sounder.
- Perimeter alarm.

Perimeter Alarm

The perimeter alarm is a deterrent against unauthorized access to your vehicle through the doors and the hood. It also protects the audio unit.

Interior Sensors (If Equipped)

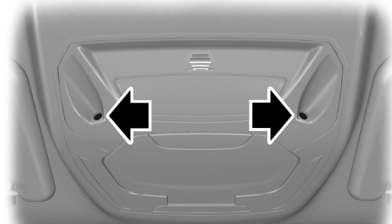

E131656

Note: *Do not cover up the interior scanning sensors.*

The sensors act as a deterrent against unauthorized intrusion by sensing any movement within your vehicle.

Battery Back-up Sounder

The battery back-up sounder is an additional alarm system this will sound a siren when the alarm is triggered. When you lock your vehicle the system is armed. The sounder has its own battery and will sound an alarm siren even if someone disconnects your vehicle battery or the battery back-up sounder itself.

Security

Triggering the Alarm

Once armed, the alarm is triggered in any of the following ways:

- If someone opens a door or the hood without a valid key or remote control.
- If someone removes the audio or navigation system.
- If you switch the ignition on without a valid key.
- If the interior sensors detect movement within your vehicle.
- On vehicles with a battery back-up sounder, if someone disconnects your vehicle battery or the battery back-up sounder itself.

If the alarm is triggered, the alarm horn will sound for 30 seconds and the hazard warning flashers will flash for five minutes.

Any further attempts to perform one of the above will trigger the alarm again.

Guard Settings

WARNING



Do not arm the alarm with full guard if passengers, animals or other moving objects are inside your vehicle. This could trigger the alarm.

Message	Description
Full guard	The interior sensors are on when you arm the alarm.
Reduced	The interior sensors are off when you arm the alarm. You can set the alarm to reduced guard for the current ignition cycle only. The alarm will reset to full guard the next time you switch the ignition on.
Ask on exit	You can set the information display to ask you each time which level of guard you wish to set. A message appears in the information display each time you switch the ignition off. If you wish to arm the alarm with reduced guard, press the OK button when this message appears. If you wish to arm the alarm with full guard, leave your vehicle without pressing the OK button.

Selecting Full or Reduced Guard

Note: *Selecting reduced guard does not set the alarm permanently to reduced guard. It sets it to reduced guard only for the current ignition cycle. If you regularly set the alarm to reduced guard, select the option to ask when you exit.*

You can select full or reduced guard using the information display. See **General Information** (page 62).

Arming the Alarm

To arm the alarm, lock your vehicle. See **Locks** (page 31).

Disarming the Alarm

Perimeter Alarm

Disarm and silence the alarm by unlocking the doors with the key and switching the ignition on with a correctly coded key or unlocking the doors with the remote control.





Category One Alarm

Disarm and silence the alarm by unlocking the doors with the key and switching the ignition on with a correctly coded key within 12 seconds or unlocking the doors with the remote control.

Power Running Boards

USING POWER RUNNING BOARDS

WARNINGS

-  In extreme climates, excessive ice buildup may occur causing the running boards not to deploy. The running boards will resume normal function once the blockage is cleared.
-  Do not step on the running boards before they have fully deployed.
-  Switch off the running boards before using the vehicle jack or placing any object under your vehicle.
-  Do not place your hand between an extended running board and your vehicle, this could result in serious personal injury.
-  Do not use the running boards, hinge assemblies, motors or the running board underbody mountings to raise your vehicle. You must use the specified jacking points.

Note: *The running board mechanism may trap debris such as mud, dirt, snow, ice and salt. This may cause unwanted noise. To overcome this issue manually deploy the running boards and wash the system with a high-pressure washing system, in particular the hinge assemblies.*

Deploy and Stow Automatically

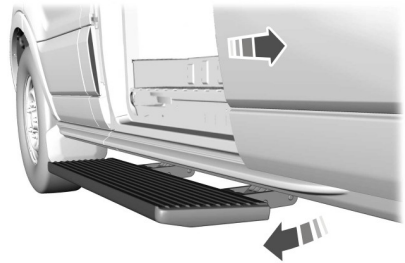

E171469

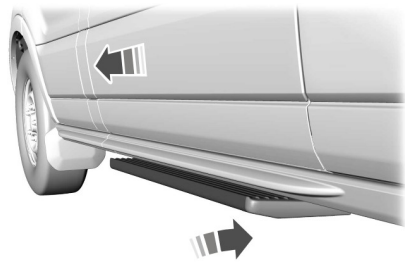

E171470

The running boards will automatically extend out when you open the sliding door. They will automatically return to the stowed position after a short period of time when you close the sliding door.

Note: *The running boards will reverse direction and move to the end of travel if they encounter an object while moving.*

Note: *The running boards may operate slower in cold temperatures.*

Power Running Boards

Switching the System On or Off

You can switch the system on or off using the vehicle settings menu in the information display. See **General Information** (page 62).

- When switched on the running boards extend and stow automatically.
- When switched off the running boards remain in the stowed position.

Deploy and Stow Using the Information Display

You can deploy and stow the running boards using the information display. See **General Information** (page 62).

Note: *If you drive off with the power running boards deployed the engine will stop.*

Manual Operation

Note: *In the event of a malfunction you can stow the running boards manually.*

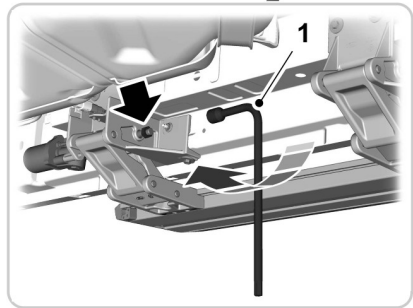

E171471

1. Insert the wheel brace into the guide hole and turn the handle clockwise until the step is in the fully stowed position.

Resetting the System

You can reset the system by opening and closing the sliding door.

Steering Wheel

ADJUSTING THE STEERING WHEEL

WARNING



Do not adjust the steering wheel when your vehicle is moving.

Note: Make sure that you are sitting in the correct position. See **Sitting in the Correct Position** (page 81).

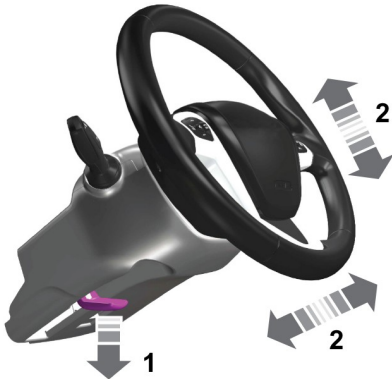

E95178

1. Unlock the steering column.
2. Adjust the steering wheel to the desired position.



E95179

3. Lock the steering column.

AUDIO CONTROL

Select the required source on the audio unit.

You can operate the following functions with the control:

Type 1



E145434

Use the arrows on the steering wheel to navigate through the menus. Press **OK** to make a selection.

Steering Wheel

Type 2

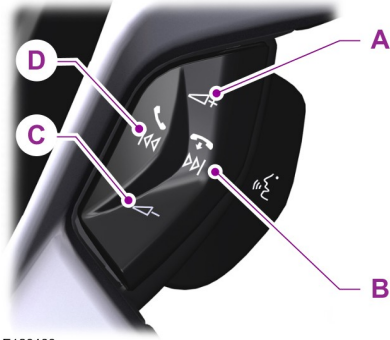

E129463

- A Volume up
- B Seek up or next
- C Volume down
- D Seek down or previous

Seek, Next or Previous

Press the seek button to:

- tune the radio to the next or previous stored preset
- play the next or the previous track.

Press and hold the seek button to:

- tune the radio to the next station up or down the frequency band
- seek through a track.

VOICE CONTROL



E129464

Pull the control to select or deselect voice control. See **SYNC™** (page 235).

CRUISE CONTROL



E142437

See **Cruise Control** (page 118).

Steering Wheel

INFORMATION DISPLAY CONTROL



E130248

See **Information Displays** (page 62).

Wipers and Washers

WINDSHIELD WIPERS

Note: Fully defrost the windshield before switching on the windshield wipers.

Note: Make sure you switch off the windshield wipers before entering a car wash.

Note: Clean the windshield and wiper blades if they begin to leave streaks or smears. If that does not resolve the issue, install new wiper blades.

Note: Do not operate the wipers on a dry windshield. This may scratch the glass, damage the wiper blades or cause the wiper motor to burn out. Always use the windshield washers before wiping a dry windshield.

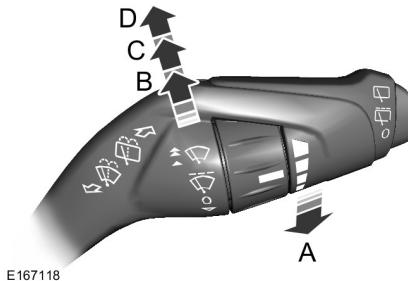

- A Single wipe
- B Intermittent wipe
- C Normal wipe
- D High speed wipe

Intermittent Wipe

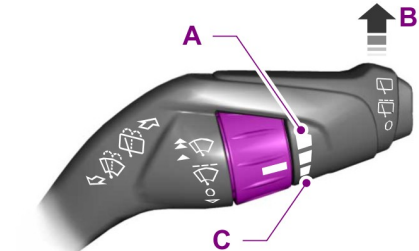

- A Short wipe interval
- B Intermittent wipe
- C Long wipe interval

Use the rotary control to adjust the intermittent wipe interval.

Speed dependent wipers (if equipped)

When your vehicle speed increases, the interval between wipes will decrease.

AUTOWIPERS

Note: Fully defrost the windshield before switching on the windshield wipers.

Note: Make sure you switch off the windshield wipers before entering a car wash.

Note: Clean the windshield and wiper blades if they begin to leave streaks or smears. If that does not resolve the issue, install new wiper blades.

Note: If you switch on the autolamps and autowipers together and the autowiper is wiping the windshield at a normal wipe speed, then the low beam headlamps will also turn on automatically.

Wipers and Washers

Note: During wet or winter driving conditions with ice, snow or a salty road mist, inconsistent or unexpected wiping or smearing may occur.

In these conditions, you can do the following:

- Lower the sensitivity of the autowipers to reduce the amount of smearing.
- Switch to normal or high-speed wipe.
- Switch the autowipers off.

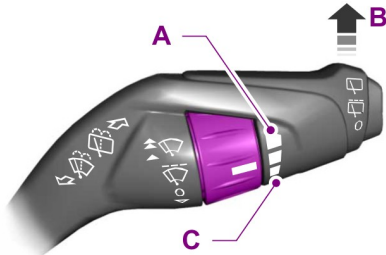

E167119

- A High sensitivity
- B On
- C Low sensitivity

The autowipers feature uses a rain sensor. You will find it in the area around the interior mirror. The rain sensor monitors the amount of moisture on the windshield and automatically turns on the wipers. It will adjust the wiper speed by the amount of moisture that the sensor detects on the windshield.

Use the rotary control to adjust the sensitivity of the rain sensor. With low sensitivity, the wipers will operate when the sensor detects a large amount of moisture on the windshield. With high sensitivity, the wipers will operate when the sensor detects a small amount of moisture on the windshield.

Keep the outside of the windshield clean because the rain sensor is very sensitive. If the area around the mirror is dirty, then the wipers may operate if dirt, mist or insects hit the windshield.

WINDSHIELD WASHERS

Note: Do not operate the washers when the washer reservoir is empty. This may cause the washer pump to overheat.

Note: Do not operate the washers for more than 10 seconds at a time.



E129188

To use the washer, pull the lever toward you. When you release the lever, the wipers will operate for a short time.

Wipers and Washers

REAR WINDOW WIPER AND WASHERS

Rear Window Wiper



E171615

- A Intermittent wipe
- B Low speed wipe
- C Off

Press the top of the button at the end of the lever to change between intermittent and low speed wipe. Press the bottom of the button to turn the wiper off.

When you switch on the front wipers and then you move the transmission selector lever to reverse (R), the rear wiper will turn on automatically to intermittent wipe.

Rear Window Washer

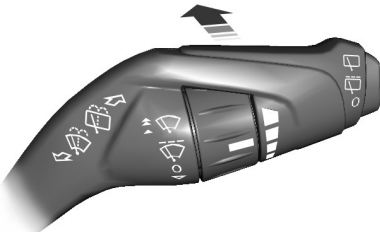

E167407

To use the washer, push the lever away from you. When you release the lever, wiping will continue for a short period of time.

Lighting

GENERAL INFORMATION

Condensation in Lamp Assemblies

Exterior lamps have vents to accommodate normal changes in air pressure.

Condensation can be a natural by-product of this design. When moist air enters the lamp assembly through the vents, there is a possibility that condensation can occur when the temperature is cold. When normal condensation occurs, a fine mist can form on the interior of the lens. The fine mist eventually clears and exits through the vents during normal operation.

Clearing time may take as long as 48 hours under dry weather conditions.

Examples of acceptable condensation are:

- The presence of a fine mist (no streaks, drip marks or large droplets).
- A fine mist covers less than 50% of the lens.

Examples of unacceptable condensation are:

- A water puddle inside the lamp.
- Streaks, drip marks or large droplets present on the interior of the lens.

If you see any unacceptable condensation, have your vehicle checked by an authorized dealer.

LIGHTING CONTROL

Lighting Control Positions

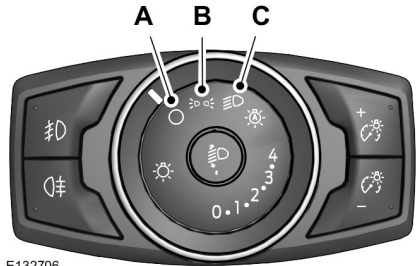

- A Off
- B Parking lamps, instrument panel lamps, license plate lamps and tail lamps
- C Headlamps

Parking Lamps (If Equipped)

Switch the ignition off.

Both Sides

To operate the parking lamps turn the lighting control to position B.

Lighting

One Side

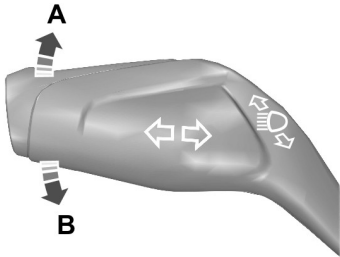

E163717

- A Right-hand side
- B Left-hand side

Note: Prolonged use of the parking lamps will cause the battery to run out of charge.

High Beams



E163718

Push the lever forward to switch the high beams on.

Push the lever forward again or pull the lever toward you to switch the high beams off.

Headlamp Flasher



E163719

Pull the lever slightly toward the steering wheel.

AUTOLAMPS



E132707

The headlamps will switch on and off automatically in low light situations or during inclement weather.

The headlamps will remain on for a period of time after you switch the ignition off. Use the information display controls to adjust the period of time that the headlamps will remain on. See **Information Displays** (page 62).

When the headlamp switch is in the Autolamps position, the windshield wiper activated exterior lamps will turn on within 10 seconds when you switch the windshield wipers on. The exterior lamps will turn off after a short period of time when you switch the windshield wipers off.

Lighting

This feature does not turn on the exterior lamps:

- During a single wipe.
- While the wipers are on to clear washer fluid during a wash condition.
- If the wipers are in automatic or intermittent modes.

Note: *If you have autolamps and autowipers switched on the low beam headlamps will turn on automatically when the windshield wipers operate continuously.*

Note: *You may have to manually switch the headlamps on in severe weather conditions.*

Note: *If you have autolamps switched on you can only switch the high beam headlamps on once the system has turned the headlamps on.*

INSTRUMENT LIGHTING DIMMER

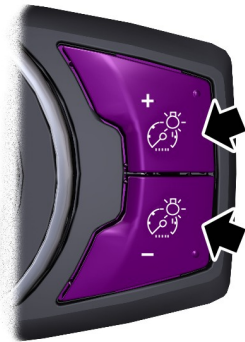

E132712

Press it repeatedly or press it and hold it until the desired level is reached.

Note: *If you disconnect the battery or it loses charge the instrument lighting will return to its brightest setting.*

HEADLAMP EXIT DELAY

After you switch the ignition off, you can switch the headlamps on by pulling the direction indicator lever toward you. You will hear a short tone. The headlamps will switch off automatically after three minutes with any door open or 30 seconds after the last door has been closed. You can cancel this feature by pulling the direction indicator toward you again or switching the ignition on.

DAYTIME RUNNING LAMPS

Daytime Running Lamps (If Equipped)

WARNING



Always remember to switch the headlamps on in low light situations or during inclement weather. The system does not turn the rear lamps on and may not provide adequate lighting. Failure to switch the headlamps on under these conditions may result in a crash.

When you switch the ignition on, the system automatically turns on.

To switch the system on:

1. Switch the ignition on.
2. Turn the lighting control switch to the off or autolamp position.

Lighting

FRONT FOG LAMPS



E132709

Press the control to switch the fog lamps on or off.

You can switch the fog lamps on when the lighting control is in any position except off.

Note: Only use fog lamps during reduced visibility, for example, fog, snow or heavy rain.

Note: If you switch autolamps on, you can only switch the fog lamps on once autolamps has turned the headlamps on.

REAR FOG LAMPS



E132710

Press the control to switch the fog lamps on or off.

You can only switch the rear fog lamps on when either the front fog lamps or low beam headlamps are on.

Note: Only use the rear fog lamps when visibility is less than 164 feet (50 meters).

Note: Do not use the rear fog lamps when it is raining or snowing.

Note: If you switch autolamps on, you can only switch the fog lamps on once autolamps has turned the headlamps on.

HEADLAMP LEVELING

Adjust the level of the headlamp beams according to your vehicle load.

Set the headlamp leveling control to zero when your vehicle is unloaded. Set the headlamp beams to give between 115 feet and 330 feet (35 meters and 100 meters) of road surface illumination when your vehicle is partially or fully loaded.

To adjust the level of the headlamp beams:

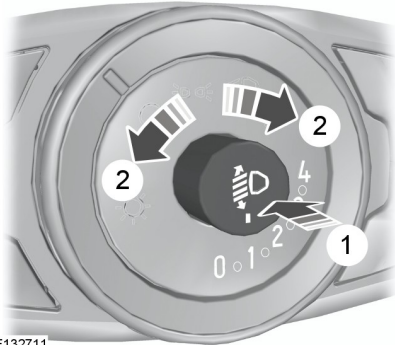

E132711

1. Press to release the control.
2. Rotate the control to the required setting.
3. Press to close the control.

Lighting

CORNERING LAMPS

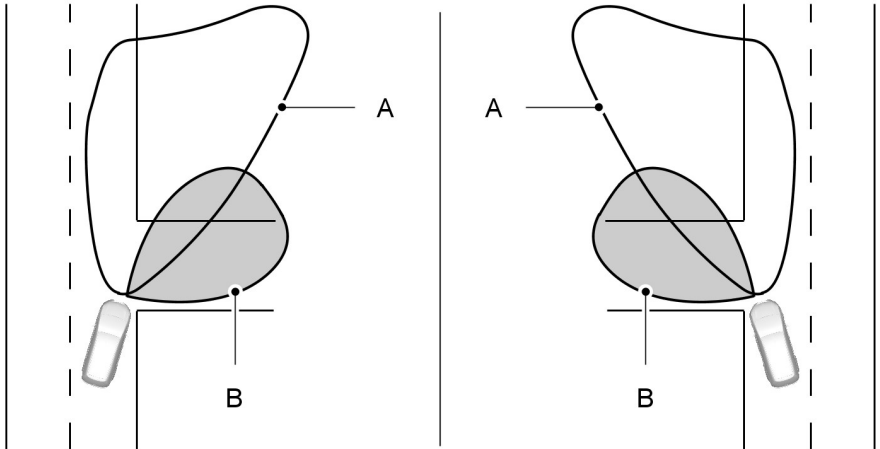

E72898

- A Headlamp beam
- B Cornering lamp beam

The cornering lamps illuminate the inside of a corner when you are turning.

DIRECTION INDICATORS



E162681

Push the lever up or down to use the direction indicators.

Note: Tap the lever up or down to make the direction indicators flash three times to indicate a lane change.

STEPWELL LAMPS

The stepwell lamps will come on and go off automatically when you open and close the doors. If you unlock the doors with the remote control, they will come on. They will go off automatically after a short time.

Lighting

INTERIOR LAMPS

Courtesy Lamp

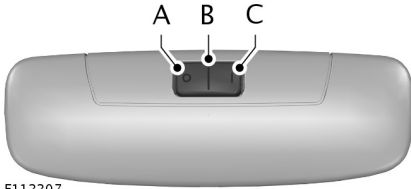

E112207

- A Off
- B Door contact
- C On

If you set the switch to position B, the courtesy lamp will switch on when you unlock your vehicle or open a door. If you leave a door open with the ignition switched off, the courtesy lamp will switch off automatically after a short period of time to prevent your vehicle battery from losing charge. To switch it back on, switch the ignition on for a short period of time.

The courtesy lamp will also switch on when you switch the ignition off. It will switch off automatically after a short period of time or when you start the engine.

If you set the switch to position C with the ignition switched off, the courtesy lamp will switch on. It will switch off automatically after a short period of time to prevent your vehicle battery from losing charge. To switch it back on, switch the ignition on for a short period of time.

Reading Lamps



E112208

If you switch the ignition off, the reading lamps will switch off automatically after a short period of time to prevent your vehicle battery from losing charge. To switch them back on, switch the ignition on for a short period of time.

Entrance Lamps

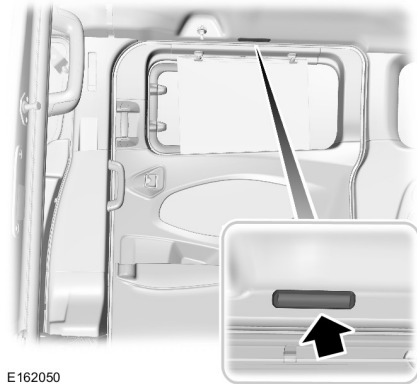

E 162050

The lamps are located above the rear doors and sliding door. They will switch on and off automatically when you open and close the doors. If you unlock the doors with the remote control, they will switch on. They will switch off automatically after a short period of time.

Windows and Mirrors

POWER WINDOWS

WARNINGS



Do not leave children unattended in your vehicle and do not let them play with the power windows. They may seriously injure themselves.



When closing the power windows, you should verify they are free of obstructions and make sure that children and pets are not in the proximity of the window openings.



E145236

Press the switch to open the window.

Lift the switch to close the window.

Note: You may hear a rumbling noise when just one of the windows are open. Lower the opposite window slightly to reduce this noise.

Note: The power windows only operate with the ignition switched on.

Driver Side One-Touch Down

Press the switch fully and release it. Press again or lift it to stop the window.

Driver Side One-Touch Up

Lift the switch fully and release it. Press or lift it again to stop the window.

Bounce-Back

The driver side window will stop automatically while closing. It will reverse some distance if there is an obstacle in the way.

Overriding the Bounce-Back Feature

To override this protection feature when there is a resistance, for example, in winter:

1. Close the window twice until it reaches the point of resistance and let it reverse.
2. Close the window a third time to the point of resistance. The bounce-back feature is now disabled and you can close the window manually. The window will go past the point of resistance and you can close it fully.

See an authorized dealer as soon as possible if the window does not close after the third attempt.

Resetting the Bounce-Back Feature

WARNING



The bounce-back feature remains turned off until it is reset.

1. Lift and hold the switch until the window is fully closed.
2. Release the switch.
3. Lift the switch again for one more second.
4. Release the switch.
5. Lift the switch again for one more second.
6. Open the window and then try to close using the one-touch feature.

Windows and Mirrors

7. Repeat the procedure if the window does not close using the one-touch feature.

Note: If you have disconnected the battery, you must reset the bounce-back memory.

EXTERIOR MIRRORS

Power Exterior Mirrors

WARNING



Do not adjust the mirrors when your vehicle is moving. This could result in the loss of control of your vehicle, serious personal injury or death.

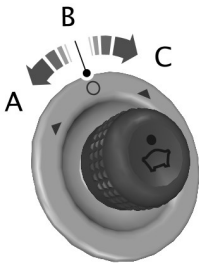

E71280

- A Left-hand mirror
- B Off
- C Right-hand mirror

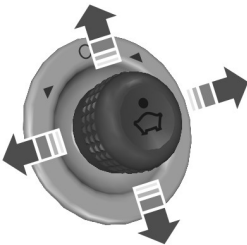

E71281

Move the controller in the direction of the arrows to adjust the mirror.

Power Folding Mirrors (If Equipped)

Folding and Unfolding

The power folding mirrors operate with the ignition on, and for several minutes after you switch the ignition off.



E72184

Move the controller downward to fold or unfold the mirrors.

Note: You can only fold the mirrors when the controller is set to position B.

Note: Continuous folding and unfolding of the mirrors will cause them to overheat and shut down for a short time. This is to avoid permanent damage.

Fold-Away Exterior Mirrors

Push the mirror toward the door window glass. Make sure that you fully engage the mirror in its support when you unfold it.

INTERIOR MIRROR

WARNING



Do not adjust the mirror when your vehicle is moving.

Note: Do not clean the housing or glass of any mirror with harsh abrasives, fuel or other petroleum or ammonia-based cleaning products.

Windows and Mirrors

You can adjust the interior mirror to your preference. Some mirrors also have a second pivot point. This lets you move the mirror head up or down and from side to side.

Pull the tab below the mirror toward you to reduce glare at night.

Auto-Dimming Mirror (If Equipped)

Note: Do not block the sensors on the front and back of the mirror. Mirror performance may be affected. A rear center passenger or raised rear center head restraint may also block light from reaching the sensor.

The mirror will dim automatically to reduce glare when bright lights are detected from behind your vehicle. It will automatically return to normal reflection when you select reverse gear to make sure you have a clear view when backing up.

REAR QUARTER WINDOWS

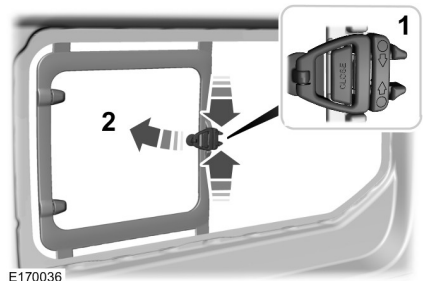

E170036

1. Press and hold the unlock button.
2. Push the window open.

SLIDING WINDOWS

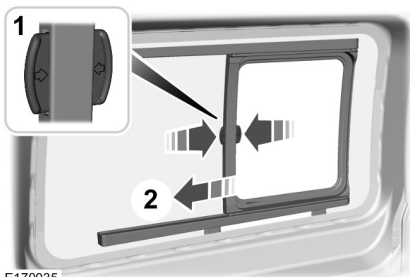

E170035

1. Press and hold the unlock button.
2. Slide the window.

Instrument Cluster

GAUGES

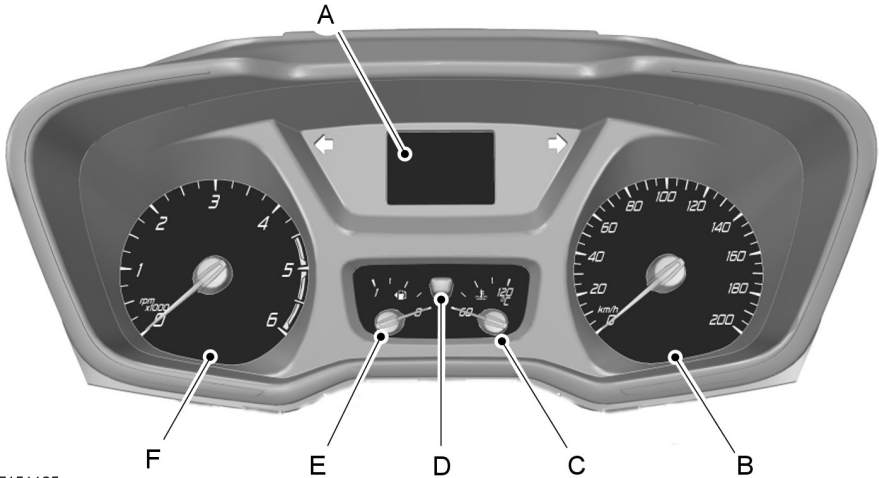

E151125

- A Odometer, tripmeter, distance to empty and Information display. See **Information Displays** (page 62).
- B Speedometer.
- C Engine coolant temperature gauge.
- D Tripmeter reset and distance to empty toggle button.
- E Fuel gauge.
- F Tachometer.

Information Display

Odometer

Registers the distance your vehicle has traveled.

Tripmeter Reset and Distance to Empty

Press the button to change between the tripmeter and distance to empty information. Press and hold the button to reset the tripmeter.

Trip Computer

See **Trip Computer** (page 67).

Outside Air Temperature

Shows the outside air temperature.

Instrument Cluster

Engine Coolant Temperature Gauge

WARNING



Never remove the coolant reservoir cap while the engine is running or hot.

At normal operating temperature, the needle will remain in the center section.

If the needle enters the red section, the engine is overheating. Stop your vehicle as soon as it is safe to do so and switch the engine off. Determine the cause once the engine has cooled down. See **Engine Coolant Check** (page 157).

Note: *Do not restart the engine until the cause of overheating has been determined and resolved.*

Fuel Gauge

Switch the ignition on. The fuel gauge will indicate approximately how much fuel is in the fuel tank. The arrow adjacent to the fuel pump symbol indicates on which side of your vehicle the fuel filler door is located.

WARNING LAMPS AND INDICATORS

The following warning lamps and indicators will alert you to a vehicle condition that may become serious. Some lamps will illuminate when you start your vehicle to make sure they work. If any lamps remain on after starting your vehicle, refer to the respective system warning lamp for further information.

Note: *Some warning indicators appear in the information display and function the same as a warning lamp but do not illuminate when you start your vehicle.*

All-Wheel Drive Lock Indicator



It will illuminate when the all-wheel drive differential lock is engaged.

Anti-Lock Brake System Warning Lamp



If it illuminates when you are driving, this indicates a malfunction. Your vehicle will continue to have normal braking without Anti-lock brake system function. Have your vehicle checked by an authorized dealer as soon as possible.

Brake Pad Wear Warning Lamp



It will illuminate when the brake pads have worn down to a predetermined limit. Have your vehicle checked by an authorized dealer as soon as possible.

Brake System Warning Lamp

WARNING



Driving your vehicle with the warning lamp on is dangerous. A significant decrease in braking performance may occur. It will take you longer to stop your vehicle. Have your vehicle checked by an authorized dealer immediately. Driving extended distances with the parking brake engaged can cause brake failure and the risk of personal injury.



It will illuminate when you engage the parking brake and the ignition is on.

Instrument Cluster

If it illuminates when your vehicle is moving, make sure the parking is disengaged. If the parking brake is disengaged, this indicates low brake fluid level or a brake system malfunction. Have your vehicle checked by an authorized dealer immediately.

Collision Warning System Indicator



It will illuminate when you switch the system off.

It will illuminate when the system is not available and may indicate a system malfunction. Have your vehicle checked by an authorized dealer as soon as possible.

Direction Indicator



Flashes during operation. A sudden increase in the rate of flashing warns of a failed indicator bulb. See **Changing a Bulb** (page 163).

Door Ajar Warning Lamp



Illuminates when you switch the ignition on and remains on if any door or the hood is open.

Engine Temperature Warning Lamp



If it illuminates when you are driving, this indicates that the engine is overheating. Stop your vehicle as soon as it is safe to do so and switch the engine off. Determine the cause once the engine has cooled down. Have your vehicle checked by an authorized dealer as soon as possible.

Engine Warning Lamps



Malfunction Indicator Lamp



Service Required Warning Lamp

All Vehicles

If either lamp illuminates when the engine is running, this indicates a malfunction. The engine will continue to run but it may have limited power. If either lamp flashes when you are driving, reduce the speed of your vehicle immediately. If it continues to flash, avoid heavy acceleration or deceleration. Have your vehicle checked by an authorized dealer immediately.

WARNING



Have this checked immediately.

If both lamps illuminate when the engine is running, stop your vehicle as soon as it is safe to do so (continued use may cause reduced power and cause the engine to stop). Switch the ignition off and attempt to restart the engine. If the engine restarts have your vehicle checked by an authorized dealer immediately.

Exhaust Emission Fluid Warning Lamp



It will illuminate when the diesel exhaust fluid is low. See **Selective Catalytic Reduction System** (page 102).

If it illuminates when your vehicle is moving, and the diesel exhaust fluid is at a sufficient level, this indicates a system malfunction. Have your vehicle checked by an authorized dealer immediately.

Instrument Cluster

Front Airbag Warning Lamp



If it fails to illuminate when you start your vehicle, continues to flash or remains on, this indicates a malfunction. Have your vehicle checked by an authorized dealer immediately.

Front Fog Lamp Indicator



It will illuminate when you switch the front fog lamps on.

Frost Warning Lamp

WARNING



Even if the temperature rises to above +39°F (4°C) there is no guarantee that the road is free of hazards caused by inclement weather.



It will illuminate when the outside air temperature is 39°F (4°C) or below.

Glow Plug Indicator



If it illuminates, wait until it extinguishes before starting.

Headlamp Indicator



It will illuminate when you switch the headlamp low beam or the side and tail lamps on.

High Beam Indicator



It will illuminate when you switch the headlamp high beam on. It will flash when you use the headlamp flasher.

Hill Start Assist Indicator



It will illuminate when the system is not available.

Note: *Not available on all instrument clusters.*

Ignition Warning Lamp



If it illuminates when driving, this indicates a malfunction. Switch off all unnecessary electrical equipment. Have your vehicle checked by an authorized dealer immediately.

Lane Departure Warning Indicator



It will illuminate when you switch the system off.

It will illuminate when the system is not available and may indicate a system malfunction. Have your vehicle checked by an authorized dealer as soon as possible.

Low Fuel Level Warning Lamp



If it illuminates, refuel as soon as possible.

Message Center Indicator



It will illuminate when a new message is stored in the information display. It will be red or amber in color depending on the severity of the message and will remain on until the cause of the message has been rectified. See **Information Messages** (page 68).

Instrument Cluster

Oil Pressure Warning Lamp

WARNING



Do not resume your journey if it illuminates despite the level being correct. Have your vehicle checked by an authorized dealer immediately.



If it stays on after starting or illuminates when driving, this indicates a malfunction. Stop your vehicle as soon as it is safe to do so and switch the engine off. Check the engine oil level. See **Engine Oil Check** (page 156).

Over Speed Warning Indicator



It will illuminate when your vehicle exceeds a set speed.

Rear Fog Lamp Indicator



It will illuminate when you switch the rear fog lamps on.

Safety Belt Minder Warning Lamp



It will illuminate and a chime will sound to remind you to fasten your safety belt. See **Safety Belt Minder** (page 26).

Shift Indicator



It will illuminate when you are recommended to shift up or down from the selected gear.



Stability Control Indicator



It will illuminate for a short period of time when you switch the ignition on. If it illuminates when you are driving, this indicates a malfunction. During a malfunction, the system turns off. Have your vehicle checked by an authorized dealer as soon as possible.

Note: *While driving, it flashes when the system is operating.*

Stability Control Off



It will illuminate when you switch the system off. It will go out when you switch the system back on or when you switch the ignition off.

Start-Stop Indicator



It will illuminate when the engine has automatically stopped. It will flash to inform you when the engine needs to restart. See **Auto-Start-Stop** (page 97). See **Information Messages** (page 68).

Low Tire Pressure Warning Indicator



It will illuminate if the tire pressure in one or more tires is below the correct pressure. See **Tire Pressure Monitoring System** (page 180).

Instrument Cluster

Water In Fuel Indicator

Vehicles with a Diesel Engine



It will illuminate if there is excess water in the fuel filter. Drain off the water immediately. See

Draining the Fuel Filter Water Trap

(page 158). If it illuminates after draining the water, this indicates a fuel filter service is required. Have your vehicle checked by an authorized dealer immediately.

Parking Brake On

Sounds when the parking brake is on and your vehicle is moving. If the warning chime remains on after you have released the parking brake, have the system checked by an authorized dealer immediately.

Safety Belt Minder

Sounds when a safety belt is unfastened in an occupied seat and your vehicle is moving.

AUDIBLE WARNINGS AND INDICATORS

Airbag Secondary Warning

Sounds when there is a fault with the airbag system and the airbag warning lamp.

Auto-Start-Stop

Sounds when the driver door is open and Auto-Start-Stop is in run mode while the engine has stopped.

Door Ajar

Sounds when a door is not fully closed and your vehicle is moving.

Emergency Door Open

Sounds continuously when the emergency door is open.

Exterior Lamps On

Sounds when the driver door is open and the exterior lamps are on.

Over Speed Warning

Sounds when your vehicle exceeds a set speed.

Information Displays

GENERAL INFORMATION

WARNING



Driving while distracted can result in loss of vehicle control, crash and injury. We strongly recommend that you use extreme caution when using any device that may take your focus off the road. Your primary responsibility is the safe operation of your vehicle. We recommend against the use of any handheld device while driving and encourage the use of voice-operated systems when possible. Make sure you are aware of all applicable local laws that may affect the use of electronic devices while driving.

You can control various systems on your vehicle using the information display controls on the steering wheel. The information display will show the corresponding information.

Information Display Controls



E138659

- Press the up and down arrow buttons to scroll through and highlight the options within a menu.
- Press the right arrow button to enter a submenu.
- Press the left arrow button to exit a submenu.
- Press the **OK** button to choose and confirm settings or messages.

Menu Structure - Information Display

You can access the menu using the information display control.

Note: Some options may appear slightly different or not at all if the items are optional.

Trip computer¹

Message
Trip computer
Dist to empty
Instant fuel
Average fuel

Information Displays

Message
Average speed
All values

¹ See **Trip Computer** (page 67). See **Gauges** (page 56).

Information

Message
Driver alert
AdBlue® level
System check

Settings

	Message	Action	
Driver assist	Traction control	On or Off	
	Driver alert	On or Off	
	Hill start assist	On or Off	
	Lane keeping	Sensitivity	
		Intensity	
	Power step	Auto	
		Deploy	
		Off	
Tyre monitor	Reset		
Forward alert	On or Off		
Lighting	Rain light	On or Off	
	Hdlamp delay	Manual or xx Seconds	
Display	Language	Choose your applicable setting	
	Measure unit	Choose your applicable setting	

Information Displays

Message		Action	
	Temp unit	Choose your applicable setting	
Chimes	Information	On or Off	
	Warning	On or Off	
Convenience	Aux heater	Park heater	On or Off
			Time 1
			Time 2
			Once
			Heat now
	Locks	Auto lock	
		Auto lock	
		Global unlock	
		Custom locking	
	Alarm	Full guard	
		Reduced	
		Ask on exit	
	System reset		Hold OK to Reset System to Factory Default

System Check

All active warnings will display first if applicable. The system check menu may appear different based upon equipment options and current vehicle status. Use the up and down arrow buttons to scroll through the list. See **Information Messages** (page 68).

Menu Structure - Information and Entertainment Display

You can access the menu using the information and entertainment display control. See **At a Glance** (page 10).

Note: *Some options may appear slightly different or not at all if the items are optional.*

SYNC-Media allows you to access the SYNC features.

Information Displays

SYNC-Phone

Message	
Dial a number	
Redial	
Phonebook	
Call history	Incoming calls
	Outgoing calls
	Missed calls
Speed Dial	
Text messaging	
BT Devices	
Phone settings	Set as master
	Phonebook pref.
	Set ringtone
	Phone status
	Text msg notify
Emerg. Assist.	

Menu

	Message	Action
SYNC-Settings	Bluetooth on	
	Set defaults	
	Master reset	
	Install on SYNC	
	System info	
	Voice settings	
	Browse USB	
SYNC-Apps		

Information Displays

Message		Action
Navigation	Route options	Route
		Driver:
		Eco settings
		Dynamic
		Motorway
		Tunnel
		Ferry/motorail
		Toll
		Seasonal roads
		Toll sticker
	Map display	Map content
		Arrows on map:
		Nav time display:
		Map heading up
		Best contrast
	Assistance options	Signs / lane
		Speed limits
		Nav icons in lists
		Hazard spot warning
	Personal data	Clear last destinations
Clear favourites		
Delete home address		
Clear all data		
Reset all settings		
Audio settings	Adaptive volume	
	Sound	
	Nav audio mixing	

Information Displays

	Message	Action
	DSP settings	
	DSP equaliser	
	TA	
	News	
	Alt. frequency	
	RDS regional	
	DAB service link	
Clock settings	Auto time (GPS)	
	Set time	
	Set date	
	Set time zone	
	Summer time	
	24-hour mode	

CLOCK

Type 1

To adjust the clock, switch the ignition on and press buttons H or M on the information and entertainment display as necessary.

Type 2

Note: Use the information display to adjust the clock. See **General Information** (page 62).

TRIP COMPUTER

Resetting the Trip Computer

Press and hold **OK** on the current screen to reset the respective trip, distance, time and average fuel information.

Trip Odometer

Registers the distance traveled of individual journeys.

Distance to Empty

Indicates the approximate distance your vehicle will travel on the fuel remaining in the tank. Changes in driving pattern may cause the value to vary.

Instantaneous Fuel Consumption

Indicates the current fuel consumption.

Average Fuel Consumption

Indicates the average fuel consumption since the function was last reset.

Average Speed

Indicates the average speed calculated since the function was last reset.

Information Displays

Outside Air Temperature

Shows the outside air temperature.

All Values

Indicates all the respective trip, distance, time and average fuel information.

PERSONALIZED SETTINGS

Measure Units

To swap between imperial and metric units, scroll to this display and press the **OK** button.

Swapping between imperial and metric units will affect the following displays:

- Distance to empty.
- Average fuel consumption.
- Instantaneous fuel consumption.
- Average speed.

Switching Chimes Off

The following chimes can be switched off:

- Warning messages.
- Information messages.

Airbag

Message	Description and Action
Airbag fault Service now	The system has detected a fault that requires service.

INFORMATION MESSAGES



E130248

Press the **OK** button to acknowledge and remove some messages from the information display. You need to confirm certain messages before you can access the menus. The information display will automatically remove other messages after a short period of time.

Note: *Depending on your vehicle options and instrument cluster type, not all of the messages will display or be available. The information display may abbreviate or shorten certain messages.*

 The message indicator illuminates to supplement some messages. The message indicator will be red or amber depending on the severity of the relevant system condition. The message indicator will remain on until a system repair is completed.

A system-specific symbol with a message indicator may supplement some messages.

Information Displays

Alarm

Message	Description and Action
Alarm triggered Check Vehicle	Indicates that there has been an activation of the anti-theft alarm. See Anti-Theft Alarm (page 36).
Alarm fault Service required	The system has detected a fault that requires service.

Battery and Charging System

Message	Description and Action
Electrical system over-voltage Stop safely	Stop your vehicle as soon as it is safe to do so and switch the ignition off. The system has detected a fault that requires service.
Battery low See manual	Switch off all unnecessary electrical systems and devices. The system has detected a fault that requires service.

Diesel Exhaust Fluid

Message	Description and Action
AdBlue® low Range XXXX mls	Indicates the approximate distance remaining before the diesel exhaust fluid tank will be empty.
AdBlue® low Range XXXX km Refill soon	Indicates the approximate distance remaining before the diesel exhaust fluid tank will be empty. Refill the diesel exhaust fluid tank as soon as possible. See Selective Catalytic Reduction System (page 102).
AdBlue® low No engine start in XXXX km	Indicates the approximate distance remaining before the diesel exhaust fluid tank will be empty and when it will restrict the engine from starting. Refill the diesel exhaust fluid tank as soon as possible. See Selective Catalytic Reduction System (page 102).
AdBlue® level empty. Refill to start engine	The diesel exhaust fluid tank is empty and is restricting the engine from starting. Refill the diesel exhaust fluid tank. See Selective Catalytic Reduction System (page 102).
AdBlue® sys malfunction Service required	The system has detected a fault that requires service.

Information Displays

Message	Description and Action
AdBlue® sys No engine start in XXXX km	The system has detected a fault that requires service.
AdBlue® sys Service required to start engine	The system has detected a fault that requires service.

Note: When filling the diesel exhaust fluid tank from empty, there may be a short period before the increased diesel exhaust fluid level is registered. The system must register the increased diesel exhaust fluid level before your vehicle will return to full power.

Door Open

Message	Description and Action
Driver door open	Stop your vehicle as soon as it is safe to do so and close the door.
Driver side rear door open	Stop your vehicle as soon as it is safe to do so and close the door.
Passenger door open	Stop your vehicle as soon as it is safe to do so and close the door.
Passenger side rear door open	Stop your vehicle as soon as it is safe to do so and close the door.
Bonnet open	Stop your vehicle as soon as it is safe to do so and close the hood.
Rear load compartment door open	Stop your vehicle as soon as it is safe to do so and close the door.
Emergency rear door open	Stop your vehicle as soon as it is safe to do so and close the door.

Engine

Message	Description and Action
Engine fault Service now	The system has detected a fault that requires service.
High engine temperature Stop safely	Stop your vehicle as soon as it is safe to do so, allow the engine to cool and then check the coolant level. If the warning remains on when you have checked the coolant level, the system has detected a fault that requires service. See Engine Coolant Check (page 157).

Information Displays

Hill Start Assist

Message	Description and Action
Hill start assist not available	The system has detected a fault that requires service. See Hill Start Assist (page 111).

Lighting

Message	Description and Action
Brake lamp Bulb fault	Indicates that a brake lamp bulb has burned out. See Lighting (page 47).
Dipped beam Bulb fault	Indicates that a low beam headlamp bulb has burned out. See Lighting (page 47).
Headlamp malfunction Service required	The system has detected a fault that requires service.

Maintenance

Message	Description and Action
Oil change required	The engine oil has exceeded the service time or distance limit. Replace the engine oil and oil filter as soon as possible. See Engine Oil Check (page 156).
Brake fluid level low Service now	The system has detected a fault that requires service. See Brake and Clutch Fluid Check (page 157).
Washer fluid level low	Refill the washer fluid reservoir as soon as possible. See Washer Fluid Check (page 158).

Parking Aid

Message	Description and Action
Parking aid malfunction Service required	The system has detected a fault that requires service. See Parking Aid (page 114).

Information Displays

Parking Brake

Message	Description and Action
Park brake applied	The parking brake is applied and your vehicle speed is above 3 mph (5 km/h). If the warning remains on when you have released the parking brake, the system has detected a fault that requires service.

Starting System

Message	Description and Action
Press brake to start	Press the brake pedal before you start the engine.
Cranking time exceeded	Indicates that the engine has failed to start.

Tire Pressure Monitoring System

Message	Description and Action
Check tyre pressures	The tire pressure is low in one or more tires, check the tire pressures. See Technical Specifications (page 190).
Tyre monitor malfunction Service required	The system has detected a fault that requires service.
Tyre sensors not detected Check hand- book	The system has detected a fault that requires service or the spare tire is in use. See Tire Pressure Monitoring System (page 180).

Traction Control

Message	Description and Action
Traction control off	Indicates that you have switched the traction control system off. See Using Traction Control (page 112).

Climate Control

PRINCIPLE OF OPERATION

Outside Air

Keep the air intakes in front of the windshield free from obstruction (such as snow or leaves) to allow the climate control system to function effectively.

Recirculated Air

WARNING



Prolonged use of recirculated air may cause the windows to mist up. If the windows mist up, follow the settings for demisting the windshield.

The air currently in the passenger compartment recirculates. Outside air does not enter your vehicle.

Heating

Heating performance depends on the temperature of the engine coolant.

Air Conditioning

Note: The air conditioning operates only when the temperature is above 39°F (4°C).

Note: When you use air conditioning, your vehicle uses more fuel.

The system directs air through the evaporator for cooling. The evaporator extracts humidity from the air to help keep the windows free of mist. The system directs the resulting condensation to the outside of your vehicle, which may cause a small pool to form under your vehicle. This is normal.

General Information on Controlling the Interior Climate

Fully close all the windows.

Warming the Interior

Direct the air toward your feet. In cold or humid weather conditions, direct some of the air toward the windshield and the door windows.

Cooling the Interior

Direct the air toward your face.

AIR VENTS

To close a vent, slide the airflow direction adjuster down.

Center Air Vents

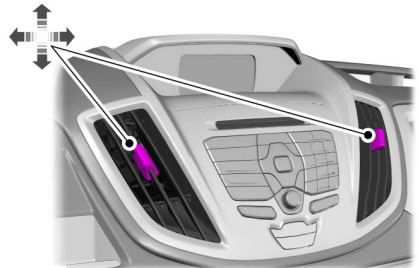

E169287

Side Air Vent

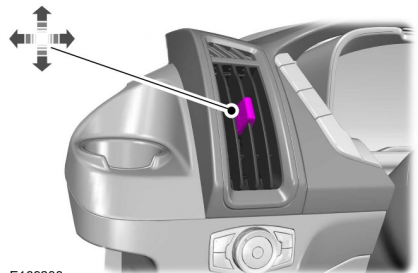

E169288

Climate Control

MANUAL CLIMATE CONTROL

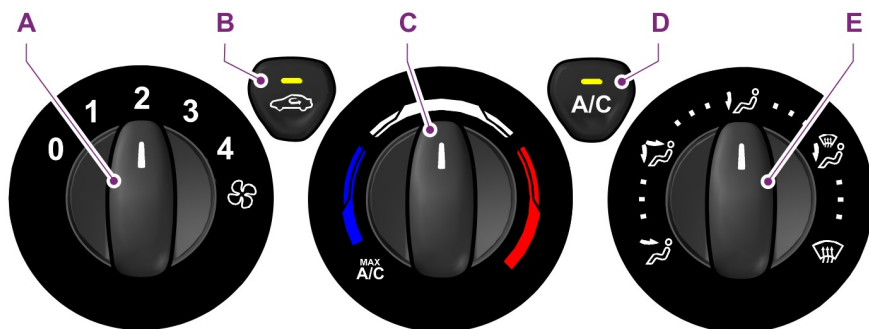

E147011

- A **Fan speed control:** Controls the volume of air circulated in your vehicle. Adjust to select the desired fan speed or switch off. If you switch the fan off, the windshield may fog up.
- B **Recirculated air:** Press the button to switch between outside air and recirculated air. When you select recirculated air, the button illuminates and the air currently in the passenger compartment recirculates. This can reduce the time needed to cool the interior and reduce unwanted odors from entering your vehicle.
- C **Temperature control:** Controls the temperature of the air circulated in your vehicle. Adjust to select the desired temperature. If you select **MAX A/C**, the system distributes recirculated air through the instrument panel air vents. This mode is more economical and efficient than normal air conditioning. Turn the temperature control to maximum heat to turn the auxiliary heater on. See **Auxiliary Heater** (page 77).
- D **Air conditioning:** Press the button to switch the air conditioning on or off. To improve air conditioning when starting your vehicle, drive with the windows open for two to three minutes.
- E **Air distribution control:** Adjust to select the desired air distribution.



Select to distribute air through the instrument panel air vents.



Select to distribute air through the footwell air vents.



Select to distribute air through the instrument panel air vents and footwell air vents.



Select to distribute air through the windshield air vents and footwell air vents.

Climate Control



Select to distribute air through the windshield air vents. You can also use this setting to defog or clear the windshield of a thin covering of ice. You can also increase the temperature and fan speed to improve clearing.

HINTS ON CONTROLLING THE INTERIOR CLIMATE

General Hints

Note: *Prolonged use of recirculated air may cause the windows to fog up.*

Note: *A small amount of air may be felt from the footwell air vents regardless of the air distribution setting.*

Note: *To reduce humidity build-up inside your vehicle, do not drive with the system switched off or with recirculated air always switched on.*

Note: *Do not place objects under the front seats as this may interfere with the airflow to the rear seats.*

Note: *Keep the air intakes in front of the windshield free from obstruction (such as snow or leaves) to allow the climate control system to function effectively.*

Note: *To reduce fogging of the windshield during humid weather, adjust the air distribution control to the windshield air vents position. Increase the temperature and fan speed and press the A/C button to improve clearing, if required.*

Heating the Interior Quickly

- Adjust the fan speed to the highest speed setting.
- Adjust the temperature control to the highest setting.
- Adjust the air distribution control to the footwell air vents position.

Recommended Settings for Heating

- Adjust the fan speed to the second speed setting.
- Adjust the temperature control to the midway point of the hot settings.
- Adjust the air distribution control to the footwell and windshield air vents position.

Cooling the Interior Quickly

- Adjust the fan speed to the highest speed setting.
- Adjust the temperature control to the **MAX A/C** position.
- Adjust the air distribution control to the instrument panel air vents position.

Recommended Settings for Cooling

- Adjust the fan speed to the second speed setting.
- Adjust the temperature control to the midway point of the cold settings.
- Adjust the air distribution control to the instrument panel air vents position.

Vehicle Stationary for Extended Periods During Extreme High Ambient Temperatures

- Apply the parking brake.
- Move the transmission selector lever to position **P** or neutral.
- Adjust the temperature control to the **MAX A/C** position.
- Adjust the fan speed to the lowest speed setting.

Climate Control

Side Window Defogging in Cold Weather

- Adjust the air distribution control to the instrument panel and windshield air vents positions.
- Press the **A/C** button.
- Adjust the temperature control to the desired setting.
- Adjust the fan speed to the highest setting.
- Direct the instrument panel side air vents toward the side windows.
- Close the instrument panel vents.

Maximum Cooling Performance in Instrument Panel or Instrument Panel and Footwell Positions

- Adjust the temperature control to the lowest setting.
- Press the **A/C** and recirculated air buttons.
- Adjust the fan speed to the highest setting initially and then adjust it to suit the desired comfort level.

REAR PASSENGER CLIMATE CONTROLS

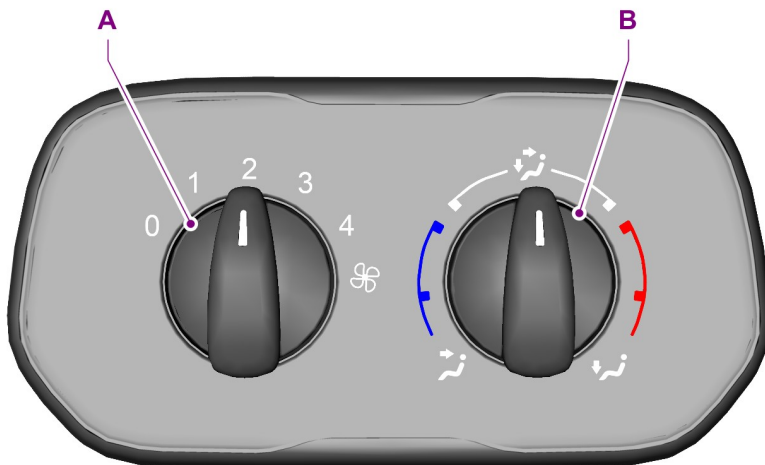

E163443

- A Fan speed control:** Controls the volume of air circulated in your vehicle. Adjust to select the desired fan speed or switch off.
- B Temperature and air distribution control:** Controls the temperature of the air circulated in your vehicle. Adjust to select the desired temperature and distribution.

Climate Control

Note: Switch the air conditioning on to cool the air through the rear air vents.

HEATED WINDOWS AND MIRRORS

Note: Make sure the engine is running before operating the heated windows.

Note: If you switch the heated windows on, the engine may not stop automatically when using Start-Stop. If you press the heated window switch when the engine has automatically stopped, an engine restart will be required. See **Auto-Start-Stop** (page 97).

Heated Windshield



Press the button to clear the window of thin ice and fog. Press the button again to switch it off. It will switch off automatically after a short period of time.

Heated Rear Window



Press the button to clear the window of thin ice and fog. Press the button again to switch it off. It will switch off automatically after a short period of time.

Note: Do not use razor blades or other sharp objects to clean the inside of the rear window or to remove decals from the inside of the rear window. This may cause damage to the heated grid lines and will not be covered by your vehicle warranty.

Heated Exterior Mirrors

Note: Do not remove ice from the mirrors with a scraper or attempt to readjust the mirror glass if it is frozen in place. These actions could cause damage to the glass and mirrors.

Note: Do not clean the housing or glass of any mirror with harsh abrasives, fuel or other petroleum-based cleaning products.

Note: On vehicles without a heated exterior mirror switch, they will switch on automatically when you switch the heated windshield or heated rear window on.



Both mirrors are heated to remove ice, mist and fog. They will switch off automatically after a short period of time.

AUXILIARY HEATER

Fuel Operated Parking Heater

WARNING



Do not use the fuel operated parking heater at fuel filling stations or near sources of combustible vapors, dust or in enclosed spaces. This could result in serious personal injury or death.

The system warms the engine and the vehicle interior, it uses fuel from the vehicle fuel tank. The system will only operate when your vehicle is stationary with the engine switched off.

Climate Control

Used correctly the system will:

- Warm the engine and the vehicle interior.
- Keep the windows clear of ice in the event of frost and prevent condensation.
- Avoid cold starts to assist the engine to reach operating temperature sooner.

Following a heating cycle, if you do not start the engine the system will not turn on the next programmed heating cycle.

Following a heating cycle we recommend that you drive your vehicle for at least the same period of time as the heating cycle. This prevents the vehicle battery from running out of charge.

We recommend you switch the system on for approximately 10 minutes every month to prevent the water pump or heater motor seizing.

The system will only operate if there is a minimum of 16 liters (3.5 gallons) of fuel in the vehicle fuel tank and the ambient temperature is below 59.0°F (15°C). The system will not operate if the battery charge level is low.

Note: *When the system is operating, exhaust fumes will come from under your vehicle. This is normal.*

Note: *On vehicles with manual climate control, heating the vehicle interior will depend on the heater control settings. See **Climate Control** (page 73).*

Programming the Fuel Operated Parking Heater

Use the information display controls on the steering wheel. See **Information Displays** (page 62).

Action	Message
1	Settings
2	Convenience
3	Park heater

Message	Description
Time 1	Allows you to programme a heating cycle for each day of the week. These times will remain stored and the system will warm up your vehicle at the programmed times.
Time 2	Allows you to programme a second heating cycle. These times will remain stored and the system will warm up your vehicle at the programmed times. Select to set a second heating cycle, for example different times on different days or twice on the same day.
Once	Allows you to programme one heating cycle for one specific day.
Heat now	Switches the heater on immediately.

Note: *You must set the time and date on the clock correctly. See **Clock** (page 67).*

Climate Control

Note: The programmed time is the time at which you need the vehicle to be warm and ready to drive, not the time at which the heater turns on.

Note: The programmed times must be set at least 70 minutes in advance of the time you wish to set.

Programming the Time Functions

Use the information display controls on the steering wheel. See **Information Displays** (page 62).

Action	Message
1	Settings
2	Convenience
3	Park heater

1. Highlight the day on which the heater should warm up the vehicle.
2. Select all the days on which the system should warm up the vehicle.
3. Set the time at which the vehicle should be warmed up and ready to drive. Highlight the time at the top of the menu and press the **OK** button. The hours start to flash.
4. Set the hours and minutes using the arrow buttons on the information display controls.

Programming the Once Function

Use the information display controls on the steering wheel. See **Information Displays** (page 62).

Action	Message
1	Settings
2	Convenience
3	Park heater
4	Once

1. Selecting this function allows you to programme one heating cycle for one specific day.
2. Set the time at which the vehicle should be warmed up and ready to drive. Highlight the time at the top of the menu and press the **OK** button. The hours start to flash.
3. Set the hours and minutes using the arrow buttons on the information display controls.

Switching Programmed Functions Off

Use the information display controls on the steering wheel. See **Information Displays** (page 62).

Action	Message
1	Settings
2	Convenience
3	Park heater

Uncheck the active programmed heating cycles as required.

Switching the Heat Now Function On

Use the information display controls on the steering wheel. See **Information Displays** (page 62).

Climate Control

Action	Message
1	Settings
2	Convenience
3	Park heater
4	Heat now

1. Press the **OK** button. An X appears in the box when the heater is switched on.
2. To switch the heater off, uncheck the option.

Switching the Heat Now Function On Using the Remote Control

1. Press the **ON** button on the remote control to switch the heater on. An X appears in the box when the heater is switched on.
2. Press the **OFF** button on the remote control to switch the heater off.

Fuel Operated Heater

The system turns on and off automatically depending on the outside air temperature and the engine coolant temperature, unless you have switched it off.

To switch off the fuel operated heater:

Use the information display controls on the steering wheel. See **Information**

Displays (page 62).



Action	Message
1	Settings
2	Convenience
3	Aux heater

Press the **OK** button. An X appears in the box when the system is switched on.

Seats

SITTING IN THE CORRECT POSITION

WARNINGS

-  Do not recline the seatback too far as this can cause the occupant to slide under the safety belt, resulting in serious injury in the event of a collision.
-  Sitting improperly, out of position or with the seatback reclined too far, can result in serious injury or death in the event of a collision. Always sit upright against your seatback, with your feet on the floor.
-  Do not place objects higher than the seatback to reduce the risk of serious injury in the event of a collision or during heavy braking.

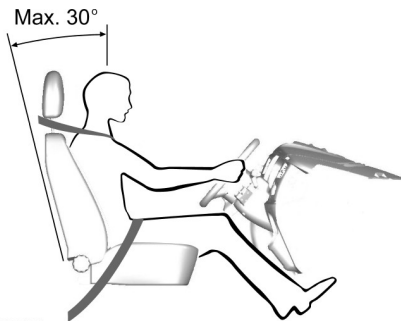

E68595

When you use them properly, the seat, head restraint, safety belt and air bags will provide optimum protection in the event of a collision.

We recommend that you follow these guidelines:

- Sit in an upright position with the base of your spine as far back as possible.
- Do not recline the seatback more than 30 degrees.

- Adjust the head restraint so that the top of it is level with the top of your head and as far forward as possible. Make sure that you remain comfortable.
- Keep sufficient distance between yourself and the steering wheel. We recommend a minimum of 10 inches (25 centimeters) between your breastbone and the air bag cover.
- Hold the steering wheel with your arms slightly bent.
- Bend your legs slightly so that you can press the pedals fully.
- Position the shoulder strap of the safety belt over the center of your shoulder and position the lap strap tightly across your hips.

Make sure that your driving position is comfortable and that you can maintain full control of your vehicle.

HEAD RESTRAINTS

WARNING

-  Fully adjust the head restraint before you sit in or operate your vehicle. This will help minimize the risk of neck injury in the event of a collision. Do not adjust the head restraint when your vehicle is moving.

Seats

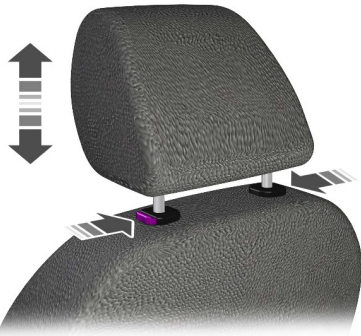

E66539

Adjusting the Head Restraint

WARNING



Raise the rear head restraint when the rear seat is occupied by a passenger or a child restraint.

Adjust the head restraint so that the top of it is level with the top of your head.

Removing the Head Restraint

Press the locking buttons and remove the head restraint.

MANUAL SEATS

WARNINGS



Do not adjust the driver seat when your vehicle is moving.



Make sure the driver seat fully locks into place by rocking it backward and forward.

Moving the Seat Backward and Forward



E130249

Note: The driver seat has removable stop bolts on the track to enable access to the vehicle battery. See **Changing the 12V Battery** (page 159).

Adjusting the Lumbar Support

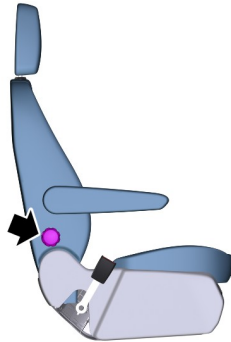

E146386

Seats

Adjusting the Height of the Driver Seat

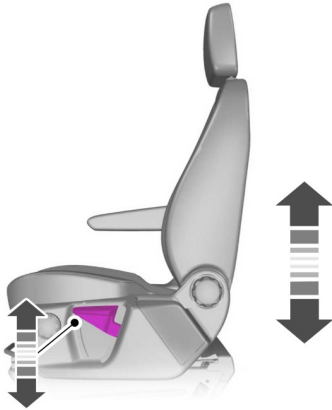

E146384

Recline Adjustment



E146385

Seat Cushion Adjustment

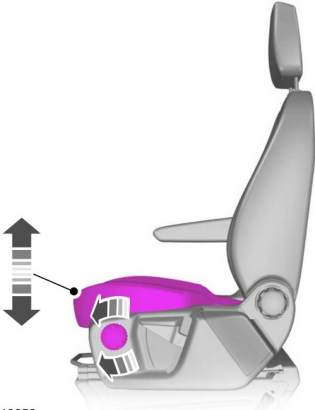

E146959

Adjusting the Armrest

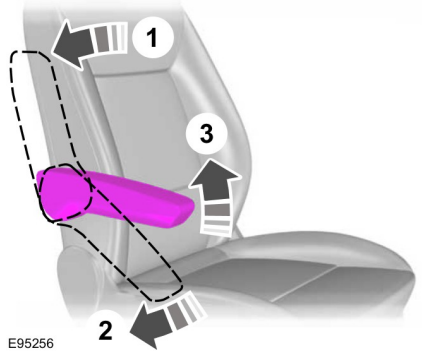

E95256

Swivel Seat

WARNING



Make sure the seat locks into place and is facing forward when your vehicle is moving.

Seats

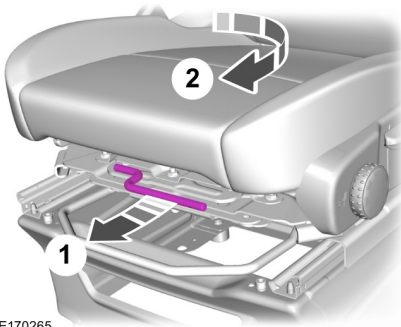



E170265

The seat can swivel through 180 degrees in an inboard direction. You may need to adjust the seat to allow sufficient clearance for it to swivel in a single motion.

Note: We recommend the seat is unoccupied.

POWER SEATS

WARNINGS

-  Do not adjust the driver's seat or seatback when your vehicle is moving.
-  Do not place cargo or any objects behind the seatback before returning it to the original position.
-  The driver's seat has removable stop bolts on the track to enable access to the vehicle battery. See **Changing the 12V Battery** (page 159).

Seats

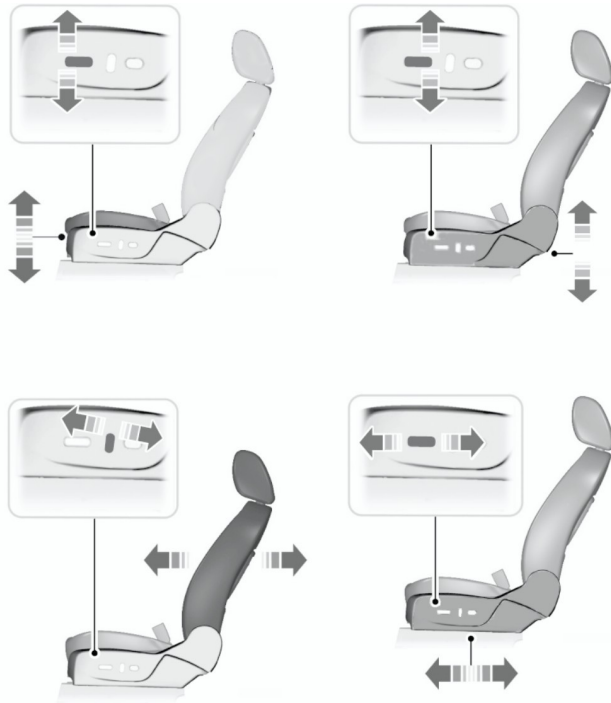

E146713

Seats

Power Lumbar



E138648

Removing Seats - M2 Bus Only.

WARNING



Seats can weigh up to 132 lb (60 kg). Do not attempt to lift or carry a seat on your own.

REAR SEATS

WARNING



Do not use the bench seats as a bed when your vehicle is moving.

Note: Rear seat arrangements vary depending on the vehicle.

Recline Adjustment

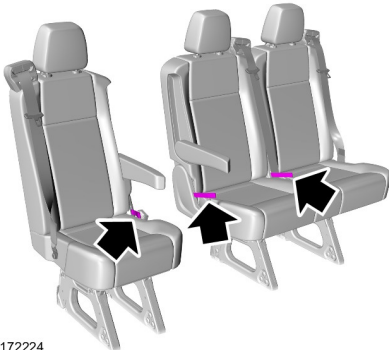

E172224

With the seat occupied, pull the lever or strap to recline or raise the seatback.

Seats

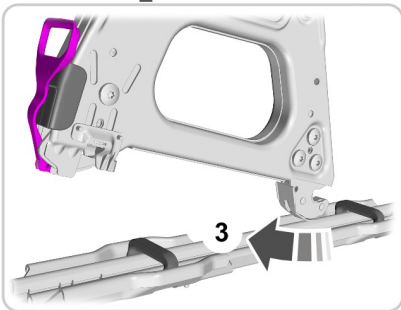
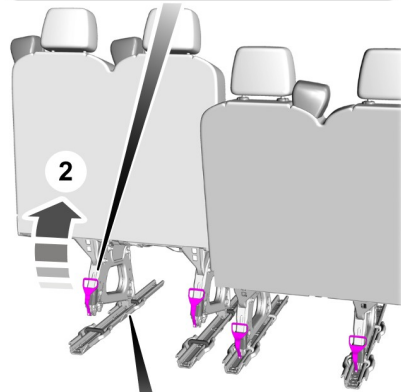
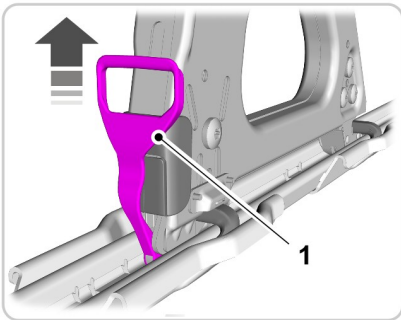

E173870

1. Pull the release handles up.

2. Tilt the seat forward to release the seat frame rear catches.
3. Pull the seat backward to release the seat frame front catches.
4. Remove the seat.

Note: You can only remove the final row dual seats.

Note: The seat back does not fold forward.

Installing the Seats

WARNINGS



Make sure that the floor catches are free from foreign material before installing the seats.



Make sure that you securely fasten the seat catches when installing.

1. Align the seat frame front catches.
2. Push the seat forward to engage the seat frame front catches.
3. Align the seat frame rear catches.
4. Allow the seat to drop under its own weight for the last 6-8 in (15-20 cm).

Seats

HEATED SEATS

WARNING



People who are unable to feel pain to their skin because of advanced age, chronic illness, diabetes, spinal cord injury, medication, alcohol use, exhaustion or other physical conditions, must exercise care when using the heated seat. The heated seat may cause burns even at low temperatures, especially if used for long periods of time. Do not place anything on the seat that insulates against heat, such as a blanket or cushion. This may cause the heated seat to overheat. Do not puncture the seat with pins, needles or other pointed objects. This may damage the heating element which may cause the heated seat to overheat. An overheated seat may cause serious personal injury.



E151818

Note: *Only the outboard seat on a dual passenger seat is heated.*

The maximum temperature is reached after five or six minutes. It is regulated thermostatically.

The heated seat will remain on until you switch it off. If the heated seat is on when you switch the ignition off, it will be on when you switch the ignition back on.

Do not do the following:

- Place heavy objects on the seat.
- Operate the heated seat if water or any other liquid is spilled on the seat. Allow the seat to dry thoroughly.
- Operate the heated seats unless the engine is running. This prevents the vehicle battery from running out of charge.

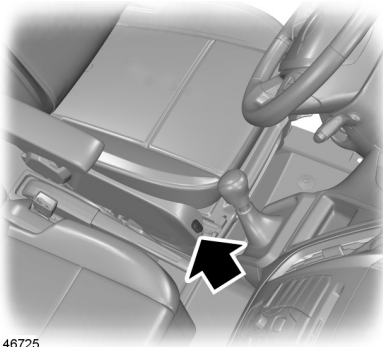

E146725

Auxiliary Power Points

WARNINGS



Do not use the power points for operating a cigar lighter element.



Do not insert objects other than an accessory plug into the power points.

Run the engine for full capacity use of the power points.

Note: Do not use the power points over the vehicle capacity of 12 volt DC 180 watt or a fuse may blow.

Note: Do not hang any accessory from the accessory plug.

Note: Always keep the power point caps closed when not in use.

Note: Incorrect use of the power points can cause damage not covered by the vehicle warranty.

To prevent the battery from running out of charge:

- Do not use the power points for longer than necessary when the engine is not running.
- Do not leave devices plugged in overnight or when your vehicle is parked for extended periods.

Note: The power points will turn off after 30 minutes if the ignition is switched on and the engine is not running.

Auxiliary Power Point Locations

WARNING



You must close the instrument panel storage compartment lid before driving your vehicle.

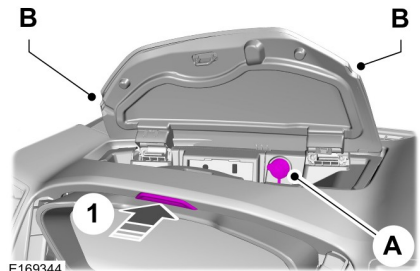

1. Press the button to open the instrument panel storage compartment lid.

A. Auxiliary power point.

B. Device cable outlet recesses.

Auxiliary Power Points may be found:

- Inside the instrument panel storage compartment.
- Inside the floor console storage compartment.
- Inside the cargo area.

AC Power Point

WARNING



Do not use any extension cord with the AC power point, since it will defeat the safety protection design provided by the cap and twist tab. Doing so may cause the power point to overload due to powering multiple devices that can reach beyond the 150 watt load limit and could result in fire or personal injury.

Auxiliary Power Points

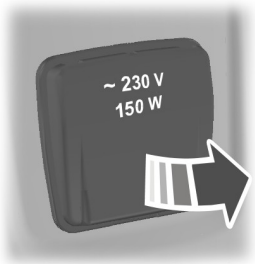

E98199

The AC power point is used for powering electrical devices that require up to 150 watts. It is located under the parking brake lever.

Note: *Do not keep electrical devices or adaptors plugged in to the AC power point when not in use.*

When the green indicator light located on the AC power point is:

- On — AC power point is ready to supply power.
- Off — AC power point is not ready to supply power; ignition is not switched on.
- Flashing — AC power point is in fault mode.

If the 150 watts limit is exceeded the AC power point will be temporarily turned off.

The indicator light will flash if the power point detects overloading, overheating, or shorting conditions. For overloaded or shorted conditions unplug your device and switch the ignition off then back on. For an overheated condition let the system cool down and switch the ignition off then back on.

The AC power point is not suitable for use with all electrical devices, for example:

- Tube type televisions.
- Vacuum cleaners.
- Power tools.

- Compressor-driven refrigerators.
- Medical or measuring equipment that must process precise data.
- Appliances requiring an extremely stable power supply, for example:
 - Microcomputer-controlled electric blankets.
 - Touch sensor lamps.

CIGAR LIGHTER

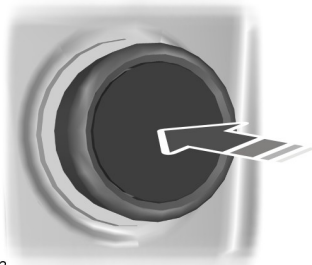

E103382



Press the element in to use the cigar lighter. It will pop out automatically.

Note: *Do not press and hold the cigar lighter element.*

Storage Compartments

CUP HOLDERS

WARNINGS

-  Do not place hot drinks in the cup holders when your vehicle is moving.
-  Make sure that cups placed in the holders do not obstruct your vision while driving.

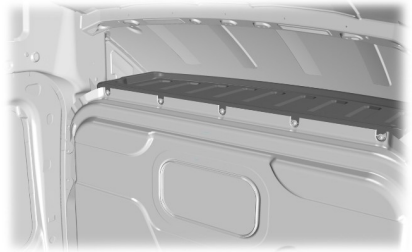

E169073

OVERHEAD CONSOLE

Overhead Storage Compartments

Overhead Console

WARNING



-  Do not place heavy objects in the overhead console. Heavy objects may become projectiles in a crash or sudden stop and may increase the risk of serious injury.



E169074

Parcel Shelf

WARNINGS

-  Do not place heavy objects on the parcel shelf.
-  The maximum permitted evenly distributed loading is 44 pounds (20 kilograms).

ASHTRAY



E171158

The ashtray can be placed in either outboard cup holder.

BOTTLE HOLDER

WARNING

-  Do not place glass objects in the bottle holder.

Storage Compartments



E171160

UNDER SEAT STORAGE

Under Seat Storage Compartment



2



E154714

1. Lift the front of the passenger seat cushion.
2. Pull the seat cushion forward.
3. Tilt the seat cushion forward.

Note: *If your vehicle has rear air conditioning, it may not have under seat storage below the outer seat.*

Storage Compartments

Under Seat Storage Guard



E172223

FRONT DOOR STORAGE COMPARTMENT

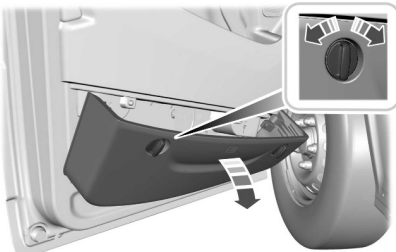

E169150

Turn the retaining clips counterclockwise to open the storage compartment.

Starting and Stopping the Engine

GENERAL INFORMATION

WARNINGS



Extended idling at high engine speeds can produce very high temperatures in the engine and exhaust system, creating the risk of fire or other damage.



Do not park, idle or drive your vehicle on dry grass or other dry ground cover. The emission system heats up the engine compartment and exhaust system, creating the risk of fire.



Do not start the engine in a closed garage or in other enclosed areas. Exhaust fumes can be toxic. Always open the garage door before you start the engine.



If you smell exhaust fumes inside your vehicle, have your vehicle checked by an authorized dealer immediately. Do not drive your vehicle if you smell exhaust fumes.

If you disconnect the battery, your vehicle may exhibit some unusual driving characteristics for approximately 5 miles (8 kilometers) after you reconnect it. This is because the engine management system must realign itself with the engine. You can disregard any unusual driving characteristics during this period.

The powertrain control system meets all Canadian interference-causing equipment standard requirements regulating the impulse electrical field or radio noise.

When you start the engine, avoid pressing the accelerator pedal before and during operation. Only use the accelerator pedal when you have difficulty starting the engine.

IGNITION SWITCH



E72128

0 (off) - The ignition is off.

Note: When you switch the ignition off and leave your vehicle, do not leave your key in the ignition. This could cause your vehicle battery to lose charge.

I (accessory) - Allows the electrical accessories such as the radio to operate while the engine is not running.

Note: Do not leave the ignition key in position **I** or **II** (without the engine running) for too long to avoid vehicle battery losing charge.

II (on) - All electrical circuits operational. Warning lamps and indicators are illuminated.

III (start) - cranks the engine. Release the key as soon as the engine starts.

STEERING WHEEL LOCK

WARNING



Always check that the steering is unlocked before attempting to move your vehicle.

To lock the steering wheel:

1. Remove the key from the ignition switch.
2. Rotate the steering wheel slightly to engage the lock.

Starting and Stopping the Engine

To unlock the steering wheel:

1. Insert the key in the ignition switch.
2. Turn the key to position **I**.

Note: You may need to rotate the steering wheel slightly to assist unlocking if there is a steering wheel load applied.

STARTING A DIESEL ENGINE

Cold or Hot Engine

Note: When the temperature is below 5°F (-15°C), you may need to crank the engine for up to 10 seconds.

Note: You can only operate the starter for a limited period of time.

Note: After a limited number of attempts to start your engine, the system will not allow you to try again until a period of time has elapsed, for example 30 minutes.



Switch the ignition on and wait until the glow plug indicator goes off.

Note: Do not touch the accelerator pedal.

Note: Releasing the clutch pedal while the engine is starting will stop the engine cranking and return to ignition on.

1. Fully depress the clutch pedal.
2. Start the engine.

Failure to Start

If the engine does not crank when the clutch pedal has been fully depressed and the ignition key is turned to position **III**.

1. Fully depress the clutch and brake pedals.
2. Turn the key to position **III** until the engine has started.

DIESEL PARTICULATE FILTER

The filter forms part of the emissions reduction system on your vehicle. It filters harmful diesel particulates (soot) from the exhaust gas.

Regeneration

WARNING



Do not park or idle your vehicle over dry leaves, dry grass or other combustible materials. The regeneration process creates very high exhaust gas temperatures and the exhaust will radiate a considerable amount of heat during and after regeneration and after you have switched the engine off. This is a potential fire hazard.

Note: Avoid running out of fuel.

Note: During regeneration at low speed or engine idle, you may smell a hot metallic odor and could notice a clicking metallic sound. This is due to the high temperatures reached during regeneration and is normal.

Note: Changes in the engine or exhaust sound may be heard during the regeneration process.

Note: After you have switched your engine off the fans may continue to run for a short period of time.

The diesel particulate filter on your vehicle requires periodic regeneration to maintain its correct function. Your vehicle will carry out this process automatically.

If your journeys meet one of the following conditions:

- You drive only short distances.
- You frequently switch the ignition on and off.
- Your journeys contain a high level of acceleration and deceleration.

Starting and Stopping the Engine

You must carry out occasional trips with the following conditions to assist the regeneration process:

- Drive your vehicle in more favorable conditions, which you will find at higher vehicle speeds in normal driving, on a main road or freeway for a minimum of 20 minutes. This drive may include short stops that will not affect the regeneration process.
- Avoid prolonged idling and always observe speed limits and road conditions.
- Do not switch the ignition off.
- Select a suitable gear to ideally maintain engine speed between 1500 and 3000 RPM.

SWITCHING OFF THE ENGINE

Vehicles With a Turbocharger

WARNING



Do not switch the engine off when it is running at high speed. If you do, the turbocharger will continue running after the engine oil pressure has dropped to zero. This will lead to premature turbocharger bearing wear.

Release the accelerator pedal. Wait until the engine has reached idle speed and then switch it off.

Unique Driving Characteristics

AUTO-START-STOP

Using Auto-Start-Stop

WARNINGS



The engine may restart automatically if required by the system. It will only automatically restart when one of the pedals is pressed. If no pedal is pressed, the Auto-Start-Stop indicator will flash and a message will appear in the information display.



Switch the ignition off before opening the hood or carrying out any maintenance.



Always switch the ignition off before leaving your vehicle, as the system may have shut down the engine but the ignition will still be live.



The system may not function if you leave extra loads connected with the ignition off.

The system helps reduce fuel consumption and CO2 emissions by shutting down the engine when your vehicle is idling, for example at traffic lights. The engine will restart when you press the clutch pedal or when required by a vehicle system, for example to prevent the vehicle battery from running out of charge.

To obtain maximum benefit from the system, move the transmission selector lever to neutral and release the clutch pedal during any stop of longer than three seconds.

Note: For vehicles with Auto-Start-Stop the battery requirement is different. You must replace the vehicle battery with one of exactly the same specification.

Note: The system only operates when the engine is warm and the outside temperature is within the system operating range.

Note: If you stall the engine and then depress the clutch pedal within five seconds, the system will automatically restart the engine.

Note: The Auto-Start-Stop indicator will illuminate green when the engine shuts down. See **Warning Lamps and Indicators** (page 57).

Note: When you switch the system off, the switch will illuminate.

Note: On vehicles with Eco system the Auto-Start-Stop system will be turned on in conjunction with the speed limiter. See **Eco Mode** (page 128). See **Speed Limiter** (page 124).

Switching the System Off and On



E170571

The system automatically turns on every time you switch the ignition on. To switch the system off, press the button in the instrument panel. The system turns off for the current ignition cycle only. To turn it on, press the button again. See **At a Glance** (page 10).

Note: If the system detects a malfunction, it will turn off. The **OFF** lamp on the **Auto-Start-Stop** switch will illuminate continuously. If this remains on after an ignition cycle, have your vehicle checked by an authorized dealer.

To Stop the Engine

1. Stop your vehicle.
2. Move the transmission selector lever to neutral.

Unique Driving Characteristics

3. Release the clutch pedal.
4. Release the accelerator pedal.

The system may not shut down the engine under certain conditions, for example:

- To prevent the vehicle battery from running out of charge.
- The outside temperature is not within the system operating range.
- The driver door has been opened.
- Low engine operating temperature.
- The heated windshield is switched on.
- During regeneration of the Diesel Particulate Filter.

To Restart the Engine

Depress the clutch pedal.

Note: *The transmission selector lever must be in neutral. If the transmission selector lever is not in neutral, the Auto-Start-Stop indicator will flash and a message will appear in the information display.*

The system may request an engine restart under certain conditions, for example:

- To prevent the vehicle battery from running out of charge.
- The heated windshield is switched on.
- Your vehicle has started moving, for example rolling forward or backward.

ECO System (If Equipped)

The system comprises of Auto-Start-Stop and a speed limiter. Together they help further reduce fuel consumption and CO₂ emissions by shutting down the engine when your vehicle is idling, and limiting vehicle top speed to 70 mph (110 km/h). See **Eco Mode** (page 128). See **Speed Limiter** (page 124).

Switching the System Off and On



E145447

The system automatically turns on every time you switch the ignition on. To switch the system off, press the button in the instrument panel. The system turns off for the current ignition cycle only. To turn it on, press the button again. See **At a Glance** (page 10).

Note: *If the system detects a malfunction, it will turn off. The **OFF** lamp on the **ECO** switch will illuminate continuously. If this remains on after an ignition cycle, have your vehicle checked by an authorized dealer.*

Fuel and Refueling

SAFETY PRECAUTIONS

WARNINGS



Do not overfill the fuel tank. The pressure in an overfilled tank may cause leakage and lead to fuel spray and fire.



The fuel system may be under pressure. If you hear a hissing sound near the fuel filler door (Easy Fuel capless fuel system), do not refuel until the sound stops. Otherwise, fuel may spray out, which could cause serious personal injury.



Automotive fuels can cause serious injury or death if misused or mishandled.



The flow of fuel through a fuel pump nozzle can produce static electricity, which can cause a fire if fuel is pumped into an ungrounded fuel container.



Fuel ethanol and gasoline may contain benzene, which is a cancer-causing agent.



When refueling always shut the engine off and never allow sparks or open flames near the filler neck. Never smoke or use a cell phone while refueling. Fuel vapor is extremely hazardous under certain conditions. Avoid inhaling excess fumes.

Observe the following guidelines when handling automotive fuel:

- Extinguish all smoking materials and any open flames before refueling your vehicle.
- Always turn off the vehicle before refueling.
- Automotive fuels can be harmful or fatal if swallowed. Fuel such as gasoline is highly toxic and if swallowed can cause death or permanent injury. If fuel is swallowed, call a physician immediately, even if no symptoms are immediately apparent. The toxic effects of fuel may not be visible for hours.
- Avoid inhaling fuel vapors. Inhaling too much fuel vapor of any kind can lead to eye and respiratory tract irritation. In severe cases, excessive or prolonged breathing of fuel vapor can cause serious illness and permanent injury.
- Avoid getting fuel liquid in your eyes. If fuel is splashed in the eyes, remove contact lenses (if worn), flush with water for 15 minutes and seek medical attention. Failure to seek proper medical attention could lead to permanent injury.
- Fuels can also be harmful if absorbed through the skin. If fuel is splashed on the skin, clothing or both, promptly remove contaminated clothing and wash skin thoroughly with soap and water. Repeated or prolonged skin contact with fuel liquid or vapor causes skin irritation.
- Be particularly careful if you are taking "Antabuse" or other forms of disulfiram for the treatment of alcoholism. Breathing gasoline vapors, or skin contact could cause an adverse reaction. In sensitive individuals, serious personal injury or sickness may result. If fuel is splashed on the skin, promptly wash skin thoroughly with soap and water. Consult a physician immediately if you experience an adverse reaction.

Fuel and Refueling

FUEL QUALITY

WARNINGS



Do not mix diesel with oil, gasoline or other liquids. This could cause a chemical reaction.



Do not add kerosene, paraffin or gasoline to diesel. This could cause damage to the fuel system.



Use diesel that meets the specification defined by EN 590 or the relevant national specification.

Note: We recommend that you use only high quality fuel.

Note: We do not recommend the use of additional additives or other engine treatments for normal vehicle use.

Note: We do not recommend the use of additional additives to prevent fuel waxing.

Long-Term Storage

Most diesel fuels contain biodiesel. We recommend that you fill the fuel tank with fuel that does not contain biodiesel if you intend to store your vehicle for more than two months. Alternatively, we recommend that you seek advice from your dealer.

RUNNING OUT OF FUEL

Avoid running out of fuel, this can cause damage not covered by the vehicle warranty.

If your vehicle has run out of fuel:

- Normally, adding five liters of fuel is enough to restart the engine. If your vehicle is on a steep grade, more fuel may be required.
- You may need to cycle the ignition from off to on several times after refueling to allow the fuel system to pump the fuel from the tank to the engine. On restarting, cranking time will take a few seconds longer than normal.

Filling a Portable Fuel Container

Use the following guidelines to avoid electrostatic charge build-up when filling an ungrounded fuel container:

- Only use an approved fuel container to transfer fuel to your vehicle. Place the container on the ground when filling.
- Do not fill a fuel container while it is inside your vehicle (including the cargo area).
- Keep the fuel pump nozzle in contact with the fuel container while filling.
- Do not use a device that holds the fuel pump nozzle lever in the fill position.

Adding Fuel From a Portable Fuel Container

WARNINGS



Do not insert the nozzle of a fuel container or an aftermarket funnel into the fuel system filler neck. This may damage the fuel system filler neck or its seal and cause fuel to run onto the ground.



Do not prise or push open a capless fuel system. This may damage the fuel system or its seal and cause fuel to run onto the ground.

Fuel and Refueling

WARNINGS

 Do not dispose of fuel in the household refuse or the public sewage system. Use an authorized waste disposal facility.

When refueling the vehicle fuel tank from a fuel container, use the plastic funnel included with your vehicle.

Note: *The specifically designed plastic funnel included with your vehicle will work safely with the fuel system.*



E 156223

1. The plastic funnel is located in the glove box.
2. Open the fuel filler door fully until it engages and remove the fuel filler cap.

Note: *Capless fuel systems do not have a fuel filler cap.*

3. Insert the plastic funnel into the filler neck.
4. Add fuel to your vehicle from the fuel container.
5. Remove the plastic funnel from the filler neck.

6. Replace the fuel filler cap and close the fuel filler door.
7. Clean the plastic funnel and place it back in your vehicle or correctly dispose of it. Extra plastic funnels can be purchased from an authorized dealer if you choose to dispose of it.





CATALYTIC CONVERTER

WARNING

 Do not park or idle your vehicle over dry leaves, dry grass or other combustible materials. The exhaust will radiate a considerable amount of heat during use, and after you have switched the engine off. This is a potential fire hazard.

Driving with a Catalytic Converter

WARNINGS

-  Avoid running out of fuel.
-  Do not crank the engine for long periods.
-  Do not run the engine when a spark plug lead is disconnected.
-  Do not push-start or tow-start your vehicle. Use booster cables. See **Jump Starting the Vehicle** (page 138).
-  Do not switch the ignition off when driving.

Fuel and Refueling

SELECTIVE CATALYTIC REDUCTION SYSTEM

WARNING

 Tampering with or disabling the selective catalytic reduction system will result in severe vehicle performance limitation.

Your vehicle has a selective catalytic reduction system to help reduce exhaust emission levels by injecting diesel exhaust fluid into the exhaust system.

Diesel Exhaust Fluid Level

For the system to operate correctly, you must maintain the diesel exhaust fluid level.

 A warning lamp will illuminate when the diesel exhaust fluid level is low and needs to be refilled.

Note: *If the warning lamp illuminates when your vehicle is moving, and the diesel exhaust fluid is at a sufficient level, this indicates a system malfunction. Have your vehicle checked by an authorized dealer as soon as possible.*

Filling the Diesel Exhaust Fluid Tank

WARNINGS

 Do not allow diesel exhaust fluid to come into contact with eyes, skin or clothing. Should the fluid come into contact with eyes, flush them with plenty of water and contact a physician. Clean affected skin with soap and water. If swallowed, drink plenty of water and contact a physician immediately

WARNINGS

 Refill the diesel exhaust fluid tank in a well-ventilated area. When removing the tank cap or a diesel exhaust fluid container cap, ammonia vapor may escape. Ammonia vapor is an irritant to the eyes, skin and mucous membranes. Inhaling ammonia vapor can cause burning to the eyes, throat and nose resulting in watering eyes or severe coughing.

 Do not put diesel exhaust fluid in the fuel tank. This can cause engine damage not covered by the vehicle warranty.



E172245

The diesel exhaust fluid tank filler neck is located next to the fuel filler neck and has a blue cap. Fill the tank using a fluid pump at a diesel exhaust fluid filling station or a diesel exhaust fluid container. The capacity of the diesel exhaust fluid tank is 21 liters.

Note: *You must open the fuel filler door before you can open the diesel exhaust fluid filler door.*

Fuel and Refueling

Note: Immediately wash off any diesel exhaust fluid that has spilled on to a painted surface with soapy water.

Filling the Diesel Exhaust Fluid Tank Using a Fuel Station Pump

Filling the diesel exhaust fluid tank using a pump is similar to a refuelling your vehicle. The diesel exhaust fluid pump nozzle will shut off automatically when the tank is full.

Note: Some filling stations utilize a magnetic mechanism in the pump nozzle that may prevent refilling the diesel exhaust fluid tank. To overcome this issue you will need to locate another filling station or use a refill container.

Filling the Diesel Exhaust Fluid Tank Using a Container

The following procedure applies to Motorcraft diesel exhaust fluid or similar fluid containers. Always follow the manufacturer's instructions.

1. Remove the diesel exhaust fluid container cap. Place the spout on to the container and tighten it until you feel a strong resistance.
2. Remove the diesel exhaust fluid tank filler cap.
3. Insert the spout in to the filler neck until the seal on the spout seats on to the filler neck. Pour the fluid in to the tank. When the tank is full the fluid will stop flowing automatically.
4. Return the container to the vertical position slightly below the diesel exhaust fluid filler neck. Allow any fluid remaining in the spout to drain back in to the container.
5. Remove the spout from the diesel exhaust fluid filler neck. Replace the diesel exhaust fluid tank cap.

6. Remove the spout from the diesel exhaust fluid container and replace the cap.

Note: If there is diesel exhaust fluid left in the container retain it for later use. The spout is re-useable. Wash the spout with clean water prior to storage. Do not use the diesel exhaust fluid spout with any other fluid.

Filling the Diesel Exhaust Fluid Tank in Cold Climates

Diesel exhaust fluid may freeze if the ambient temperature is below 12°F (-11°C). Your vehicle has a preheating system which allows diesel exhaust fluid to operate below 12°F (-11°C). If you do not use your vehicle for an extended period when the ambient temperature is below 12°F (-11°C), the fluid in the tank may freeze. If the tank is overfilled and the fluid freezes it may damage the tank. This is not covered by the vehicle warranty.

Contaminated Diesel Exhaust Fluid or Inoperative Selective Catalytic Reduction System



If the system becomes contaminated or inoperative, the diesel exhaust fluid warning lamp will illuminate and a message will appear in the information display.

Note: To service a contaminated or inoperative system, see an authorized dealer.

Diesel Exhaust Fluid Guidelines

- Do not put diesel exhaust fluid in the vehicle fuel tank.
- Do not overfill the diesel exhaust fluid tank.
- Do not dilute diesel exhaust fluid with water or any other liquid.
- Do not re-use a diesel exhaust fluid container.

Fuel and Refueling

- Do not store in direct sunlight.
- Store at temperatures between 23°F (-5°C) and 68°F (20°C).
- Do not store a diesel exhaust fluid container in your vehicle.
- Diesel exhaust fluid is non-flammable, non-toxic, colorless and water-soluble.

REFUELING

WARNINGS

 When refueling always shut the engine off and never allow sparks or open flames near the filler neck. Never smoke or use a cell phone while refueling. Fuel vapor is extremely hazardous under certain conditions. Avoid inhaling excess fumes.

 Wait at least 10 seconds before removing the fuel pump nozzle from the filler neck to allow any residual fuel to drain into the fuel tank.

 Stop refueling after the fuel pump nozzle automatically shuts off for the second time. Additional fuel will fill the expansion space in the fuel tank which could lead to fuel overflowing.

 Do not remove the fuel pump nozzle from its fully inserted position in the filler neck during the entire refueling process.

 Do not overfill the fuel tank. The pressure in an overfilled tank may cause leakage and lead to fuel spray and fire.

Do not attempt to start the engine if you have refueled the fuel tank with the incorrect fuel. This can cause damage not covered by the vehicle warranty. Have your vehicle checked by an authorized dealer immediately.

If you use a high pressure spray to wash your vehicle, only spray the fuel filler door briefly from a distance not less than 8 in (200 mm).

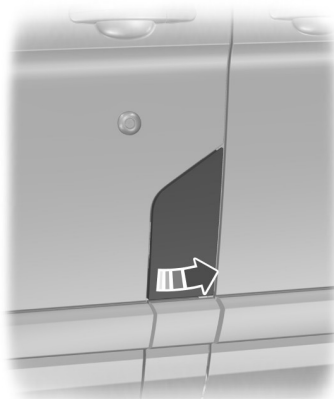

E144358

Note: Capless fuel systems do not have a fuel filler cap.

Note: Your vehicle must be unlocked, with the door open before opening and closing the fuel filler door.

1. Open the fuel filler door fully until it engages and remove the fuel filler cap.

Fuel and Refueling

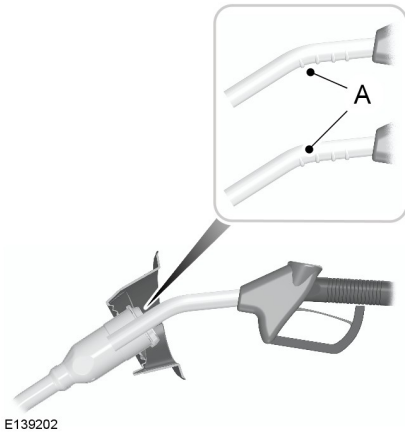

Note: When you insert the correct size fuel pump nozzle into a capless fuel system, a spring loaded inhibitor will open. This helps to avoid refueling with the incorrect fuel.

2. Insert the fuel pump nozzle up to the first notch on the nozzle A. Keep it resting on the cover of the fuel pipe opening.

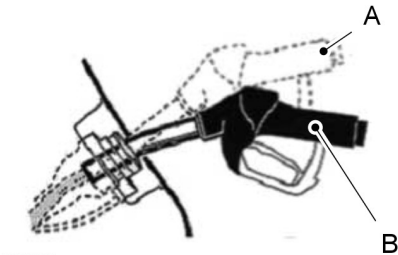

3. Hold the fuel pump nozzle in position B during refueling. Holding the fuel pump nozzle in position A may affect the flow of fuel and shut off the fuel pump nozzle before the fuel tank is full.

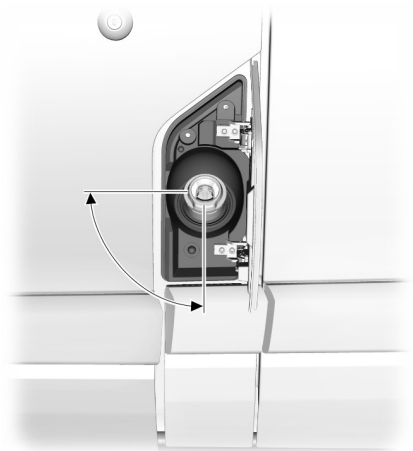

4. Operate the fuel pump nozzle within the area shown.

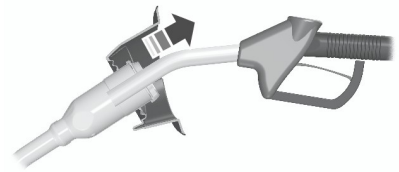

5. Slightly raise the fuel pump nozzle and remove it slowly.
6. Replace the fuel filler cap and close the fuel filler door.

Note: Capless fuel systems do not have a fuel filler cap.

Fuel and Refueling

FUEL CONSUMPTION

Note: *The amount of usable fuel in the empty reserve varies and should not be relied upon to increase driving range. When refueling your vehicle after the fuel gauge indicates empty, you might not be able to refuel the full amount of the advertised capacity of the fuel tank due to the empty reserve still present in the fuel tank.*

The CO₂ and fuel consumption figures are derived from laboratory tests according to Regulation (EC) 715/2007 and subsequent amendments are carried out by all vehicle manufacturers.

They are intended as a comparison between makes and models of vehicles. They are not intended to represent the real world fuel consumption you may get from your vehicle.

Real world fuel consumption is governed by many factors including: driving style, high speed driving, stop-start driving, air conditioning usage, the accessories fitted, payload, towing, etc.

The advertised capacity is the indicated capacity and the empty reserve combined. Indicated capacity is the difference in the amount of fuel in the fuel tank and when the fuel gauge indicates empty. Empty reserve is the amount of fuel in the fuel tank after the fuel gauge indicates empty.

Filling the Fuel Tank

For consistent results when refueling:

- Switch the ignition off.
- Allow no more than two automatic shut-offs when refueling.

Results are most accurate when the refueling method is consistent.

Calculating Fuel Economy

Do not measure fuel economy during the first 1000 mi (1,600 km) of driving (this is the engine break-in period). A more accurate measurement is obtained after 2500 mi (4,000 km). Also, fuel expense, frequency of fill ups or fuel gauge readings are not accurate ways to measure fuel economy.

1. Fill the fuel tank completely and record the initial odometer reading.
2. Each time you fill the fuel tank, record the amount of fuel added.
3. After at least three to five fuel tank fill ups, fill the fuel tank and record the current odometer reading.
4. Subtract your initial odometer reading from the current odometer reading.
5. Calculate fuel economy by dividing miles traveled by gallons used (For Metric: Multiply liters used by 100, then divide by kilometers traveled).

Keep a record for at least one month and record the type of driving (city or freeway). This provides an accurate estimate of your vehicle's fuel economy under current driving conditions. Additionally, keeping records during summer and winter show how temperature impacts fuel economy. In general, your vehicle will use more fuel in cold temperatures.

Transmission

MANUAL TRANSMISSION

Selecting Reverse Gear

Do not engage reverse gear when your vehicle is moving. This can cause damage to the transmission.

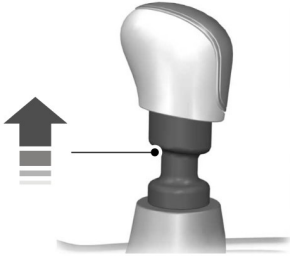

E99067

Raise the collar when you select reverse gear.

All-Wheel Drive

USING ALL-WHEEL DRIVE

Note: When recovering an all-wheel drive vehicle, you must have all wheels either on or off the ground. See **Towing the Vehicle on Four Wheels** (page 134).

If the system malfunctions, you will see a message in the information display. See **Information Messages** (page 68). Have your vehicle checked by an authorized dealer.

Automatic Mode

The all-wheel drive system, fitted to certain rear-wheel drive models, will automatically distribute driving torque to the front wheels according to the road conditions and engine load. Automatic mode is suitable for most conditions.

All-Wheel Drive Lock Mode

Note: Your vehicle may exhibit some unusual driving characteristics when you leave the all-wheel drive lock mode on when driving on normal road surfaces.

Note: All-wheel drive will remain on until switched off or the ignition is switched off.



All-wheel drive vehicles are equipped with an enhanced all-wheel drive lock mode of operation. Press the all-wheel drive lock button to turn on. See **Instrument Panel Overview** (page 12).

When using all-wheel drive lock mode, the all-wheel drive system applies increased torque to the front wheels continually. When you use all-wheel drive lock mode on normal road surfaces, you may experience some unusual driving characteristics.

The electronic stability control system will automatically enter a reduced operating mode and enhance the available engine torque. The electronic stability control off warning will appear in the information display. The anti-lock braking system and traction control continue to operate fully.

In all-wheel drive lock mode the increased torque applied to the front axle, in conjunction with full engine torque will give maximum traction to the driver. Use this mode in certain conditions; for example in deep sand or snow.

Press the all-wheel drive lock button again to return to the automatic mode.

Brakes

GENERAL INFORMATION

WARNING



Driving while distracted can result in loss of vehicle control, crash and injury. We strongly recommend that you use extreme caution when using any device that may take your focus off the road. Your primary responsibility is the safe operation of your vehicle. We recommend against the use of any handheld device while driving and encourage the use of voice-operated systems when possible. Make sure you are aware of all applicable local laws that may affect the use of electronic devices while driving.

Note: Occasional brake noise is normal. If a metal-to-metal, continuous grinding or continuous squeal sound is present, the brake linings may be worn-out. If your vehicle has continuous vibration or shudder in the steering wheel while braking, have your vehicle checked by an authorized dealer.

Note: Brake dust may accumulate on the wheels, even under normal driving conditions. Some dust is inevitable as the brakes wear. See **Cleaning the Alloy Wheels** (page 175).

Note: Depending upon certain laws and regulations, the brake lamps may flash during heavy braking. Following this your hazard warning flashers may also flash when your vehicle comes to a stop.

Wet brakes result in reduced braking efficiency. Gently press the brake pedal a few times when driving from a car wash or standing water to dry the brakes.

Brake Assist

Brake assist detects when you brake heavily by measuring the rate at which you press the brake pedal. It provides maximum braking efficiency as long as you press the pedal. Brake assist can reduce stopping distances in critical situations.

Anti-lock Brake System

This system helps you maintain steering control and vehicle stability during emergency stops by keeping the brakes from locking.

HINTS ON DRIVING WITH ANTI-LOCK BRAKES

Note: When the system is operating, the brake pedal will pulse and may travel further. Maintain pressure on the brake pedal. You may also hear a noise from the system. This is normal.

The anti-lock braking system will not eliminate the risks when:

- you drive too closely to the vehicle in front of you
- your vehicle is hydroplaning
- you take corners too fast
- the road surface is poor.

Brakes

PARKING BRAKE

Center Parking Brake



E172225

To apply the parking brake:

1. Press the foot brake pedal firmly.
2. Pull the parking brake lever up to its fullest extent.

To release the parking brake:

1. Press the foot brake pedal firmly.
2. Pull the parking brake lever up slightly.
3. Press the release button and push the parking brake lever down.

Note: If you park your vehicle facing uphill turn the steering wheel away from the curb.

Note: If you park your vehicle facing downhill turn the steering wheel toward the curb.

Note: Do not press the release button while pulling the parking brake lever up.

Outboard Parking Brake (If Equipped)



E172222

To apply the parking brake:

1. Press the foot brake pedal firmly.
2. Pull the parking brake lever up to its fullest extent.

To release the parking brake:

1. Press the foot brake pedal firmly.
2. Pull the parking brake lever up to its fullest extent.
3. Press the release button and push the parking brake lever down.

Note: If you park your vehicle facing uphill turn the steering wheel away from the curb.

Note: If you park your vehicle facing downhill turn the steering wheel toward the curb.

Note: Do not press the release button while pulling the parking brake lever up.

Note: When applied, the parking brake lever will return to the completely down position and a warning lamp will illuminate.

HILL START ASSIST

WARNINGS



The system does not replace the parking brake. When you leave your vehicle, always apply the parking brake. Failure to leave your vehicle securely parked may lead to a crash or injury. See (page 62).



You must remain in your vehicle once the system activates. This could result in the loss of vehicle control, serious personal injury or death.



During all times, you are responsible for controlling your vehicle, supervising the system and intervening, if required. Failure to take care may result in the loss of control of your vehicle, serious personal injury or death.



The system will turn off if a malfunction is apparent or if you rev the engine excessively. Failure to take care may result in the loss of control of your vehicle, serious personal injury or death.

Note: *The system will not operate if the parking brake is applied.*

The system makes it easier to pull away when your vehicle is on a slope without the need to use the parking brake.

When the system is active, your vehicle will remain stationary on the slope for two to three seconds after you release the brake pedal. This allows time to move your foot from the brake to the accelerator pedal. The system releases the brakes automatically once the engine has developed sufficient drive to prevent your vehicle from rolling down the slope. This is an advantage when pulling away on a slope, for example from a car park ramp, traffic lights or when reversing uphill into a parking space.

Using Hill Start Assist

1. Press the brake pedal to bring your vehicle to a complete standstill. Keep the brake pedal pressed.
2. If the sensors detect that your vehicle is on a slope, the system will activate automatically.
3. When you remove your foot from the brake pedal, your vehicle will remain on the slope without rolling away for approximately two to three seconds. This hold time will automatically be extended if you are in the process of driving off.
4. Drive off in the normal manner. The system will release the brakes automatically.

Switching the System On and Off

Your vehicle comes with this feature already enabled. If required, you can switch this feature off using the information display. See **General Information** (page 62).

The system will remain on or off depending on how it was last set.

Traction Control

PRINCIPLE OF OPERATION

The traction control system helps avoid drive wheel spin and loss of traction.

If your vehicle begins to slide, the system applies the brakes to individual wheels and, when needed, reduces engine power at the same time. If the wheels spin when accelerating on slippery or loose surfaces, the system reduces engine power in order to increase traction.

USING TRACTION CONTROL

The system automatically turns on each time you switch the ignition on.

Note: *In some situations for example if your vehicle is stuck in snow or mud, turning the system off may be beneficial as this allows the wheels to spin with full engine power.*

Switching the System Off and On Using the Information Display Controls

Your vehicle comes with this feature already enabled. If required, you can switch this feature off using the information display controls. See **General Information** (page 62).

Stability control will remain on even when you have switched the traction control off.

Switching the System Off and On Using the Button (If Equipped)

The button is located in the instrument panel.

Press the button. You will see a message in conjunction with an illuminated icon in the display. Press the button again to return the system to normal mode.

Stability control will remain on even when you have switched the traction control off.

Stability Control

PRINCIPLE OF OPERATION

Electronic Stability Program

WARNING



The system does not relieve you of your responsibility to drive with due care and attention. Failure to do so could result in loss of vehicle control, personal injury or death.

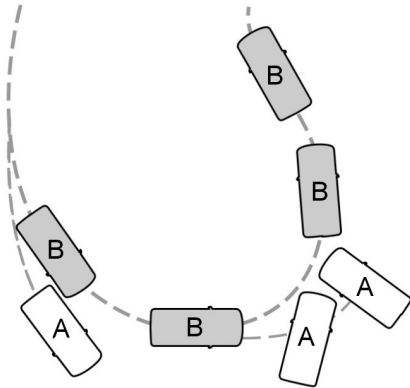

E72903

- A Without ESP
- B With ESP

The system supports stability when your vehicle starts to slide away from your intended path. The system performs this by braking individual wheels and reducing engine torque as required.

The system also provides an enhanced traction control function by reducing engine torque if the wheels spin when you accelerate. This improves your ability to pull away on slippery roads or loose surfaces, and improves comfort by limiting wheel spin in hairpin bends.

Stability Control Warning Lamp

While driving, it flashes when the system is operating. See **Warning Lamps and Indicators** (page 57).

USING STABILITY CONTROL

The system automatically turns on each time you switch the ignition on.

Switching the System Off and On Using the Information Display Controls

Your vehicle comes with this feature already enabled. If required, you can switch this feature off using the information display. See **General Information** (page 62).

Stability control will remain on even when you have switched the traction control off.

Switching the System Off Using a Switch (If Equipped)

The switch is located in the instrument panel.

Press the switch. You will see a message in conjunction with an illuminated icon in the display. Press the switch again to return the system to normal mode.

Stability control will remain on even when you have switched the traction control off.

Parking Aids

PRINCIPLE OF OPERATION

WARNINGS



The system does not relieve you of your responsibility to drive with due care and attention.



If your vehicle has a non-Ford approved trailer tow module the system may not correctly detect objects.



The sensors may not detect objects in heavy rain or other conditions that cause disruptive reflections.



The sensors may not detect objects with surfaces that absorb ultrasonic waves.



The system does not detect objects that are moving away from your vehicle. They will only be detected shortly after they start to move toward your vehicle.



Take particular care when reversing with a tow ball arm or a rear fitted accessory. For example, a bicycle carrier. The rear parking aid will only indicate the approximate distance from the rear bumper to an object.



If you use a high pressure spray to wash your vehicle, only spray the sensors briefly from a distance not less than eight inches (20 centimeters).

Note: If your vehicle has a tow ball arm, the system is turned off automatically when trailer lamps (or lighting boards) are connected to the 13-pin socket through a Ford approved trailer tow module.

Note: Keep the sensors free from dirt, ice or snow. Do not clean with sharp objects.

Note: The system may emit false alerts if it detects a signal using the same frequency as the sensors or if your vehicle is fully loaded.

Note: The outer sensors may detect the side walls of a garage. If the distance between the outer sensors and the side wall remains constant for three seconds, the alert will turn off. As you continue the inner sensors will detect objects directly behind your vehicle.

PARKING AID

WARNINGS



The parking aid system can only assist you to detect objects when your vehicle is moving at parking speeds. To help avoid personal injury you must take care when using the parking aid system.



Traffic control systems, inclement weather, air brakes, external motors and fans may affect the correct operation of the sensing system. This may cause reduced performance or false alerts.



The system may not detect small or moving objects, particularly those close to the ground.

The system warns you of objects that are within the detection zone of the bumper areas. When you switch the ignition on, the system automatically turns on. The system becomes active when you shift into reverse (R) and the speed of your vehicle is 10 mph (16 km/h) or less.

Parking Aids

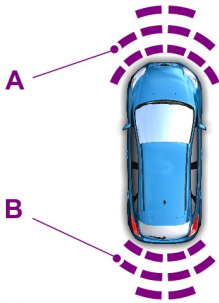

E174857

- A Front detection zone: Up to 31 in (80 cm) directly in front of the front bumper, and approximately 6–14 in (15–35 cm) to the side of the front bumper.
- B Rear detection zone: Up to 72 in (183 cm) from the rear bumper.

Note: Accessories that block the detection zone of the system may create false alerts.

Note: Keep the sensors free from snow, ice and large accumulations of dirt.

Note: If your vehicle sustains damage leaving the sensors misaligned, this will cause inaccurate measurements or false alerts.

A tone will sound in the following manner when objects are near the front or rear bumpers:

- Objects detected by the front sensors produce a high-pitched tone from the front speakers.
- Objects detected by the rear sensors produce a low-pitched tone from the rear speakers.

- The system reports the object that is closest to the front or rear of your vehicle. For example, if an object is 24 in (60 cm) from the front of your vehicle and at the same time, an object is only 16 in (40 cm) from the rear of your vehicle, a lower-pitched tone sounds from the rear speakers.
- An alternating tone sounds from the front and rear speakers if there are objects that are closer than 10 in (25 cm) from the front and rear of your vehicle.
- An alert will only sound for three seconds if an object is further than 10 in (25 cm) from the side of your vehicle.

Note: The rate of the tone increases as your vehicle moves closer to an object.

When the parking aid system sounds a tone, the audio system may reduce the set volume. When the warning ends, the audio system returns to the previously set volume.

Note: Volume reduction is not a standard feature of all audio systems.

The system detects objects when you shift into reverse (R) and:

- Your vehicle is moving toward a stationary object at a speed of 3 mph (5 km/h) or less.
- Your vehicle is stationary but an object is approaching your vehicle at a speed of 3 mph (5 km/h) or less.
- Your vehicle is moving at a speed of 3 mph (5 km/h) or less, and an object is approaching your vehicle at a speed of 3 mph (5 km/h) or less.

Parking Aids

Switching the Parking Aid System Off



E170949

Press the button to switch the system off. The system remains off until you switch the ignition off.

REAR VIEW CAMERA

WARNINGS



Objects in the display are closer than they appear.



The operation of the camera may vary depending on the ambient temperature, vehicle and road conditions.



Do not place objects in front of the camera.



The camera may not detect objects that are very close to your vehicle.



E170301

The camera is on the rear cargo door or liftgate.

Switching the Rear View Camera On

Switch the ignition on and shift into reverse (R). The image will display in the interior mirror.

The camera may not operate correctly in any of the following conditions:

- Dark areas.
- Intense light areas.
- If there is a sudden change to the ambient temperature.
- If the camera is wet.
- If the camera is dirty.
- If the camera is obstructed.

Using the Display

WARNING



Objects above the camera may not be visible. Check the area behind your vehicle when necessary.

The lines show a projected vehicle path and the approximate distance from the rear bumper to an object.

Distance markers are only a guide and are calculated for unloaded vehicles on an even road surface.

Parking Aids

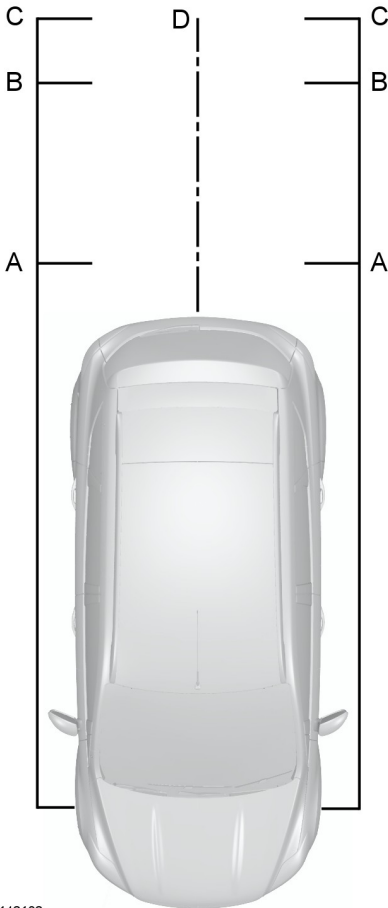

E142132

- A Red - up to 12 inches (0.3 meter).
- B Amber - 12 inches to 24 inches (0.3 meter to 0.6 meter).

- C Green - 24 inches to 35 inches (0.6 meter to 0.9 meter).
- D Black - center line of the projected vehicle path.

Note: The green line is extended from 35 in (0.9 m) up to a distance of 126 in (3.2 m).

Note: When reversing with a trailer the camera will show the direction of your vehicle and not the direction of the trailer.

Note: When reversing with a trailer the screen does not display the lines.

Switching the Rear View Camera Off

Move the transmission selector lever from reverse (R).

Note: The system will turn off after a short period of time.

Vehicles with Parking Aid

The display will show a colored distance bar. This indicates the approximate distance from the rear bumper to an object.

These are color coded as follows:

- Red - up to 12 in (0.3 m).
- Amber - 12 in (0.3 m) to 24 in (0.6 m).
- Green - 24 in (0.6 m) to 71 in (1.8 m).

Cruise Control

PRINCIPLE OF OPERATION

WARNING



The system does not relieve you of your responsibility to drive with due care and attention.

Cruise control allows you to control your speed using the switches on the steering wheel. You can use cruise control when you exceed approximately 20 mph (30 km/h).

USING CRUISE CONTROL

WARNINGS



Do not use cruise control in heavy traffic, on winding roads or when the road surface is slippery. This could result in loss of vehicle control, serious injury or death.



When you are going downhill, your vehicle speed may increase above the set speed. The system will not apply the brakes. Change down a gear to assist the system in maintaining the set speed. Failure to do so could result in loss of vehicle control, serious injury or death.

Note: Cruise control will disengage if your vehicle speed decreases more than 10 mph (16 km/h) below your set speed while driving uphill.



E142437

The cruise controls are located on the steering wheel.

Switching Cruise Control On

Press and release **ON**.



The indicator will display in the instrument cluster.

Setting a Speed

1. Accelerate to the desired speed.
2. Press and release **SET+**.
3. Take your foot off the accelerator pedal.

Changing the Set Speed

- Press and hold **SET+** or **SET-**. Release the control when you reach the desired speed.
- Press and release **SET+** or **SET-**. The set speed will change in approximately 1 mph (2 km/h) increments.
- Press the accelerator or brake pedal until you reach the desired speed. Press and release **SET+**.

Canceling the Set Speed

Pull **CAN** toward you and release, or tap the brake pedal. The set speed will not be erased.

Cruise Control

Resuming the Set Speed

Pull **RES** toward you and release.

Switching Cruise Control Off

Note: You will erase the set speed if you switch the system off.

Press and release **OFF** or switch the ignition off.

USING ADAPTIVE CRUISE CONTROL

WARNINGS



The system is not a crash warning or avoidance system. You must intervene if the system does not detect a vehicle in front of you.



When you use the system you are responsible for maintaining the correct distance and speed. Always pay attention to the traffic conditions and intervene when the system is not maintaining a suitable speed or distance.



The system does not relieve you of your responsibility to drive with due care and attention.



The system does not brake for slow or stationary vehicles, pedestrians, objects in the road, oncoming and crossing vehicles.



Do not use the system in poor visibility, specifically fog, heavy rain, spray or snow.



Do not use the system on icy or slippery roads.



Do not use the system when entering or leaving a freeway.

The system helps you maintain a gap from the vehicle in front of you. If there is no vehicle in front of you the system will maintain a set speed. The system is intended to provide enhanced operation of your vehicle when following other vehicles which are in the same lane and traveling in the same direction.

The system is based on the use of a radar sensor which projects a beam directly forward of your vehicle. This beam will detect any vehicle ahead within the system's range.

The radar sensor is located behind the front grille.

Note: Only use the system when conditions are favorable, for example on freeways and main roads with steady free flowing traffic.

Note: The radar sensor has a limited field of vision. In some situations it may detect a vehicle other than the one expected or not detect any vehicle at all.

Note: When you switch the system on, it is possible that you will hear some unusual sounds during automatic braking. This is normal and caused by the automatic braking system.

Note: Keep the front of your vehicle free from dirt, metal badges or objects. This includes vehicle front protectors and additional lights which may prevent the sensor from operating.

Cruise Control

Detection Beam Issues

A

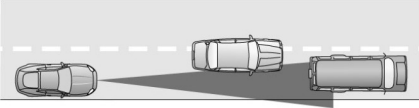

B

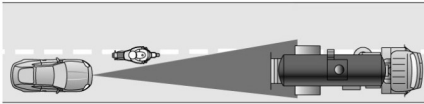

C

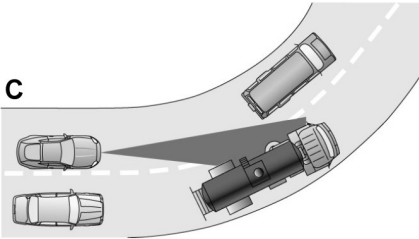

E71621

Detection issues can occur:

- With vehicles that edge into your lane that can only be detected once they have moved fully into your lane (**A**). Motorcyclists may be detected late, or not at all (**B**).
- With vehicles in front of you when going into and coming out of a bend (**C**). The detection beam will not follow sharp curves in the road.

In these cases the system may brake late or unexpectedly. You should stay alert and intervene if necessary.

Automatic Braking

WARNINGS

 You must take immediate action once alerted, as the adaptive cruise control braking will not be sufficient to keep a safe distance to the vehicle in front of you.

 In some cases there may be no warning or the warning may be delayed. You should always apply the brakes when necessary.

 When following a vehicle, the system will not automatically decelerate to a stop.

If required, the system will automatically brake for you to maintain the set gap between your vehicle and the one detected in front of you. This braking capacity is limited to approximately 30% of the total manual braking capacity to maintain smooth and comfortable cruising. If your vehicle needs to brake heavily and you do not intervene by braking manually, an alarm will sound and the display will show a warning symbol.

Cruise Control

Using the System

Use the steering wheel controls to operate the system.

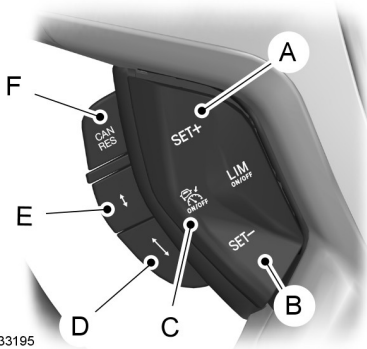

E133195

- A Set speed increase
- B Set speed decrease
- C On and off
- D Gap increase
- E Gap decrease
- F Cancel and resume

Switching the System On

Press switch C. The system is set to standby mode.

Setting a Speed

Press switch A or B to select your set speed. The speed is stored as a set speed and displayed in the information display.

Note: The system must be in standby mode.

Changing the Set Speed

Press switch A to increase or switch B to decrease the set speed until the desired set speed is shown in the information display. Your vehicle speed will gradually change to the selected speed.

Note: Vehicle speed may be increased and decreased at intervals of 5 mph or 5 km/h depending on your unit of measure setting.

Note: If the system does not react to these changes the reason may be that the gap interval to the vehicle in front of you prevents an increase in speed.

Setting the Vehicle Gap

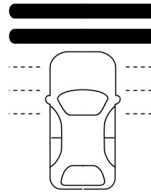

E82311

The distance between you and the vehicle detected in front of you is maintained by a variable setting. The information display will show the variable setting as horizontal bars. Selecting one bar gives the smallest gap and selecting all bars gives the largest gap. When in standby mode the bars are empty and when in use they are full.

When the system does not detect a vehicle in front of you, you will only see your vehicle displayed in the information display below the bars. The system will maintain the set speed when conditions permit. The system also maintains the set gap and displays this in the information display.

Cruise Control

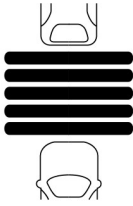

E82312

When the system detects a vehicle in front of you, the display will show the vehicle above the horizontal bars.

This is a follow mode. The system will accelerate or decelerate as necessary to maintain the set gap. The selected gap will determine the acceleration behavior of the system.

Pull switch E to decrease the gap or switch D to increase the gap. The number of bars in the information display represents the set gap.

Note: Use the appropriate gap setting in accordance with local traffic regulations.

Note: The gap setting is time dependent and therefore the distance will automatically adjust with your speed. For example on a gap setting of four bars, the time gap is 1.8 seconds. This will mean that at a speed of 62 mph (100 km/h), the distance to the vehicle in front of you will be maintained at 164 feet (50 meters).

Note: If you depress the accelerator briefly, for example when overtaking another vehicle, the system will temporarily switch off. It will turn back on when you release the accelerator pedal. The information display will show a message.

Note: The gap setting will remain unchanged each time you switch the ignition on.

Note: The recommended gap setting is four bars.

Standby Mode

Press the brake pedal or pull switch F to cancel the system. The system will return to standby mode allowing you full manual control of your vehicle. The memory will retain the set speed and gap setting.

Pull switch F again to resume. The system will resume with the previously set speed and gap setting if conditions permit.

Note: You will cancel the system if you move the transmission selector lever to neutral or depress the clutch or accelerator pedal for a long period of time.

Switching the System Off

Press switch C.

Note: This will not retain the stored speed.

Automatic Switch Off

The system is dependent on various other systems, for example anti-lock brake system and electronic stability assist. When a safety system has a malfunction or is reacting to an emergency, the system will automatically switch off.

You will hear an audible tone and a message will appear in the information display. You must then intervene and adapt your driving and speed to vehicles in front of you.

Automatic switch off can occur if:

- Your vehicle speed falls below approximately 17 mph (25 km/h).
- The tires lose traction.
- The brake temperature is too high, for example when driving on mountainous or hilly roads.
- The engine speed is too low.
- The radar sensor is covered.
- You apply the parking brake.

Cruise Control

Note: A message will appear in the display if the engine speed drops too low. It will advise you to change down a gear (manual transmission only). If you do not follow this recommendation then the system will automatically switch off.

Forward Alert Function

WARNINGS



Never wait for a crash warning. When driving you are responsible for maintaining the correct distance and speed, even when the system is used.



The system will only react to vehicles in front of you traveling in the same direction and will not react to slow or stationary vehicles.



Never drive in a manner to provoke the system. The system is designed to assist in emergencies only.



Warnings may be absent, triggered late or triggered unnecessarily due to detection beam issues. See

Principle of Operation (page 118).

The system will warn you of the risk of a crash with the vehicle in front of you.

The system will alert you with an audible tone and a visual warning in the information display.

Brake support assists with full braking and reduces the severity of a crash with the vehicle in front of you.

Note: The brake support system only reduces the crash speed if you brake immediately once alerted.

Note: If you depress the brake pedal quick enough, you will maintain full braking. This is regardless of how much force you apply to the pedal.

Note: Brake support prepares the braking system for rapid braking by gently applying the brake. You may notice a slight jerk.

Note: Crash alerts will only occur when you switch the system on. Brake support is always on and you can not turn it off.

Note: You can use the system with or without switching the adaptive cruise control system on.

Note: The system uses the same radar sensors as adaptive cruise control and therefore has the same limitations. See **Principle of Operation** (page 118).

Switching the System On and Off

You can switch the system on and off using the information display. See **General Information** (page 62).

Note: When you switch the system off, a warning indicator will remain illuminated in the information display. See **Warning Lamps and Indicators** (page 57).

Note: The system status and settings will remain unchanged each time you switch the ignition on.

Adjusting the Warning Sensitivity

This will determine how early the system alerts you. You can adjust the sensitivity using the steering wheel controls. See **General Information** (page 62).

Driving Aids

SPEED LIMITER

Engine Speed Limiter

Engine speed is limited to protect the engine.

Vehicle Speed Limiter - Fixed

The system prevents you from driving faster than a programmed speed. See the label on the driver sun visor for further information.

Vehicles with a Diesel Engine

You can have the maximum speed of your vehicle limited to a predefined value, providing it is within legal limits. See an authorized dealer for further information.

Vehicles with Start-Stop

When start-stop is switched on your vehicle speed is limited to 70 mph (110 km/h).

Note: *If your vehicle has a fixed speed limit lower than 70 mph (110 km/h), this will override the switchable speed limiter associated with start-stop.*

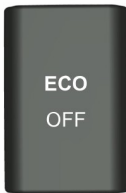

E145447

The system automatically turns on every time you switch the ignition on. To turn this speed limit off, press the **ECO** switch. The system will only turn off for the current ignition cycle. To turn it on, press the switch again. For item location: See **Instrument Panel Overview** (page 12).

Vehicle Speed Limiter - Adjustable

WARNING



When you are going downhill, your vehicle speed may increase above the set speed. The system will not apply the brakes but a warning is given.

The system allows you to set a speed, to which your vehicle is then limited. The set speed will become the effective maximum speed of your vehicle, but with the option to temporarily exceed this limit if required.

Note: *You can exceed the set speed limit if required. For example, when overtaking.*



E133198

- A Set speed increase
- B Speed limiter on and off
- C Set speed decrease
- D Speed limiter cancel and resume

Switching the System On and Off

Press switch B. The information display will prompt you to set a speed.

Driving Aids

Setting the Speed Limit

Press switch A or switch C to select your desired speed limit. The speed is stored as a set speed and displayed in the information display.

Pull switch D to cancel the limiter and place it in standby mode. The information display will confirm the system is off.

Pull switch D again to resume the limiter. The information display will confirm the system is on.

Intentionally Exceeding the Set Speed Limit

Depress the accelerator fully to temporarily turn the system off. The system will turn on once your vehicle speed drops below the set speed.

System Warnings

If you accidentally exceed the set speed, it will flash in the information display and you will hear an audible tone.

If you exceed the set limit intentionally, the information display will show the set speed and it will flash.

DRIVER ALERT

Principle of Operation

WARNINGS



The system does not relieve you of your responsibility to drive with due care and attention.



At all times you are responsible for controlling your vehicle, supervising the system and intervening if required.



If the sensor becomes blocked the system may not function.

WARNINGS



Take regular rest breaks as required and do not wait for the system to warn you if you feel tired.



Take rest breaks only where it is safe to do so.



Certain driving styles and behavior may result in the system issuing a warning even if you are not feeling tired.



In cold and severe weather conditions the system may not function. Rain, snow, spray and large contrasts in lighting can all influence the sensor.



The system will not operate if the sensor cannot track the road lane markings.



The system may not operate in areas during roadwork construction.



The system may not operate on roads with sharp bends or narrow lanes.



Do not carry out windshield repairs in the immediate area surrounding the sensor.



If your vehicle has a suspension kit not approved by us, the system may not function correctly.

Note: Keep the windshield free from obstructions such as bird droppings, insects and snow or ice.

Note: The system assists you when driving on fast main roads and freeways.

Note: The system calculates an alertness level at vehicle speeds above approximately 40 mph (65 km/h).

The system automatically monitors your driving behavior.

Driving Aids

The system is designed to alert you if it detects that you are becoming drowsy or if your driving deteriorates.

Using Driver Alert

Switching the System On and Off

Note: *The system will remain on or off depending on how it was last set.*

Switch the system on using the information display. See **Information Displays** (page 62).

The system will calculate your alertness level based upon your driving behavior in relation to the lane markings and other factors.

System Warnings

Note: *The system will not issue warnings below approximately 40 mph (65 km/h).*

The warning system has two stages:

1. A temporary warning is issued to advise you to take a rest. This message only appears for a short time.
2. If you do not rest and the system continues to detect that your driving deteriorates, it will issue a further warning. This will remain in the information display until you cancel it. See **Information Messages** (page 68).

Press **OK** on the steering wheel control to remove the warning.

System Display

When active the system will run automatically in the background and only issue warnings if required. You can view the status at any time using the information display. See **General Information** (page 62).

The alertness level is shown by six steps as a colored bar.



E131358

Alertness level is fine, no rest required.

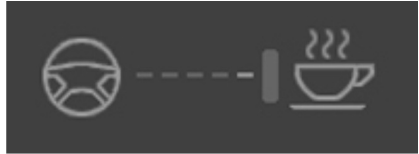

E131359

Alertness level is critical, indicating that you should take a rest as soon as it is safe to do so.

The status bar will travel from left to right as the calculated alertness level decreases. As the rest icon is approached the color turns from green to yellow and then finally red when a rest break must be taken.

- Green: No rest required.
- Yellow: First (temporary) warning.
- Red: Second warning.

Your alertness level will be shown in grey if:

- the camera sensor cannot track the road lane markings
- your vehicle speed drops below approximately 40 mph (65 km/h).

Resetting the System

You can reset the system by:

- switching the ignition off and on
- stopping your vehicle and then opening and closing the driver's door.











Driving Aids

LANE KEEPING SYSTEM

Lane Keeping Alert

Principle of Operation

WARNINGS

-  The system does not relieve you of your responsibility to drive with due care and attention.
-  At all times you are responsible for controlling your vehicle, supervising the system and intervening if required.
-  If the sensor becomes blocked the system may not function.
-  The sensor may incorrectly track lane markings such as other structures or objects. This can result in a false or missed warning.
-  In cold and severe weather conditions the system may not function. Rain, snow, spray and large contrasts in lighting can all influence the sensor.
-  The system will not operate if the sensor cannot track the road lane markings.
-  The system may not operate in areas during roadwork construction.
-  The system may not operate on roads with sharp bends or narrow lanes.
-  Do not carry out windshield repairs in the immediate area surrounding the sensor.
-  If your vehicle has a suspension kit not approved by us, the system may not function correctly.

Note: Keep the windshield free from obstructions such as bird droppings, insects and snow or ice.

Note: The system may assist you when driving on fast main roads and freeways.

Note: The system may not operate during hard braking or acceleration and when you are intentionally steering your vehicle.

Note: The system will operate with a minimum of one tracked lane marking.

Note: The system will only operate above vehicle speeds of approximately 40 mph (65 km/h).

The sensor is located behind the interior mirror. It continuously monitors conditions to alert you of unintentional lane drifting at high speeds.

The system will automatically detect and track the lane markings on the road. If your vehicle unintentionally drifts toward the road lane markings, you will see a warning in the information display. There is also a warning given in the form of a vibration felt through the steering wheel.

Note: The vibration intensity from the steering wheel may decrease depending on the quality of the road surface.

Using Lane Keeping Alert

Switching the System On and Off



E132099

Turn the system on and off using the button on the direction indicator stalk.

Press the button twice to turn the system on. Press the button once to turn the system off.

Driving Aids

Note: When you switch the system off, a warning indicator will remain illuminated in the information display. See **Warning Lamps and Indicators** (page 57).

Note: The system status and settings will remain unchanged when you switch the ignition on and off.

Setting the Steering Wheel Vibration Level

The system has three intensity levels which you can set using the information display. See **General Information** (page 62).

Setting the System Sensitivity

You can adjust how quickly the system warns you of a dangerous situation. The system has two sensitivity levels which you can set using the information display. See **General Information** (page 62).

System Warnings



E152382

A column of lane markings are displayed either side of the vehicle graphic.

The lane markings are color coded as follows:

- Green: The system is ready to warn you of any unintentional lane departure.
- Red: Your vehicle is approaching or is too close to the detected lane boundary. Take immediate safe action to reposition your vehicle.
- Gray: The system will suppress the relevant lane boundary.

Instances where a lane boundary may be suppressed:

- The sensor may not detect the lane markings on the road.
- You turn the direction indicator for that side of your vehicle on.
- If you apply direct steering, accelerate fast or brake hard.
- Your vehicle speed is outside the operating limits.
- If there is an anti-lock brake or stability control intervention.
- Narrow lane width.

If the lane markings in the display turn red or you feel a vibration through the steering wheel you must take immediate and safe action to align your vehicle. Correct any unintended lane drift immediately.



ECO MODE

This system assists you in driving more efficiently by constantly monitoring characteristics of gear changing, anticipation of traffic conditions and speeds while driving.

Driving Aids

The petals shown in the display represent value characteristics with five petals being the most efficient. The more efficiently you drive, the better the rating, and the better your overall fuel economy.

Note: *These efficiency values do not result in a defined fuel consumption figure. It might vary as it is not only related to these driving habits, but also influenced by many other factors such as short trips and cold starts.*

Note: *Frequent short trips, where the engine does not fully warm up, will also increase fuel consumption.*

You can access the system using the information display. See **General Information** (page 62).

Type 1

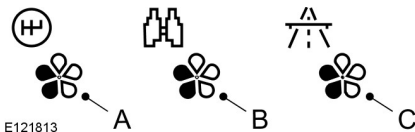

- A Gear shifting
- B Anticipation
- C Efficient speed

Gear shifting

Using the highest drivable gear appropriate for the road conditions will improve fuel consumption.

Anticipation

Adjust your vehicle speed and the distance to other vehicles to avoid the need for heavy braking or acceleration to improve fuel economy.

Efficient speed

Reduce your cruising speed on open roads to improve economy. Higher speeds use more fuel.

Type 2 and 3

The information display will show the corresponding information.

Resetting Eco Mode







Reset the average fuel consumption by using the information display control.

Note: *New values may take a short time to calculate.*

Load Carrying

GENERAL INFORMATION

WARNINGS

-  Use load securing straps to an approved standard, e.g. DIN.
-  Make sure that you secure all loose items properly.
-  Place luggage and other loads as low and as far forward as possible within the luggage or loadspace.
-  Do not drive with the liftgate or rear door open. Exhaust fumes may enter your vehicle.
-  Do not exceed the maximum front and rear axle loads for your vehicle. See **Vehicle Identification Plate** (page 204).
-  Do not allow items to contact the rear windows.





Note: When loading long objects in to your vehicle, for example pipes, timber or furniture be careful not to damage the interior trim.

ROOF RACKS AND LOAD CARRIERS

WARNINGS

-  When loading the roof racks, we recommend you evenly distribute the load, as well as maintain a low center of gravity. Loaded vehicles, with higher centers of gravity, may handle differently than unloaded vehicles. Take extra precautions, such as slower speeds and increased stopping distance, when driving a heavily loaded vehicle.

WARNINGS

-  Do not exceed the maximum axle load for your vehicle. See **Vehicle Identification Plate** (page 204).
-  Read and follow the manufacturer's instructions when you are fitting a roof rack.
-  Do not place loads directly on the roof panel.
-  If you use a roof rack, the fuel consumption of your vehicle will be higher and you may experience different driving characteristics.
-  Do not exceed the maximum roof load for your vehicle.

Variant	Maximum Roof Load lb (kg)
Medium Roof	331 lb (150 kg)
High Roof	220 lb (100 kg)

Make sure that you securely fasten the load. Check to make sure the straps are secure before driving and at each fuel stop.

When using the roof rack system, we recommend you use Ford genuine accessory crossbars designed specifically for your vehicle.

LOAD RETAINING FIXTURES

Note: The number of load retaining fixtures may vary depending on your vehicle model.

Load Carrying

Securing Cargo

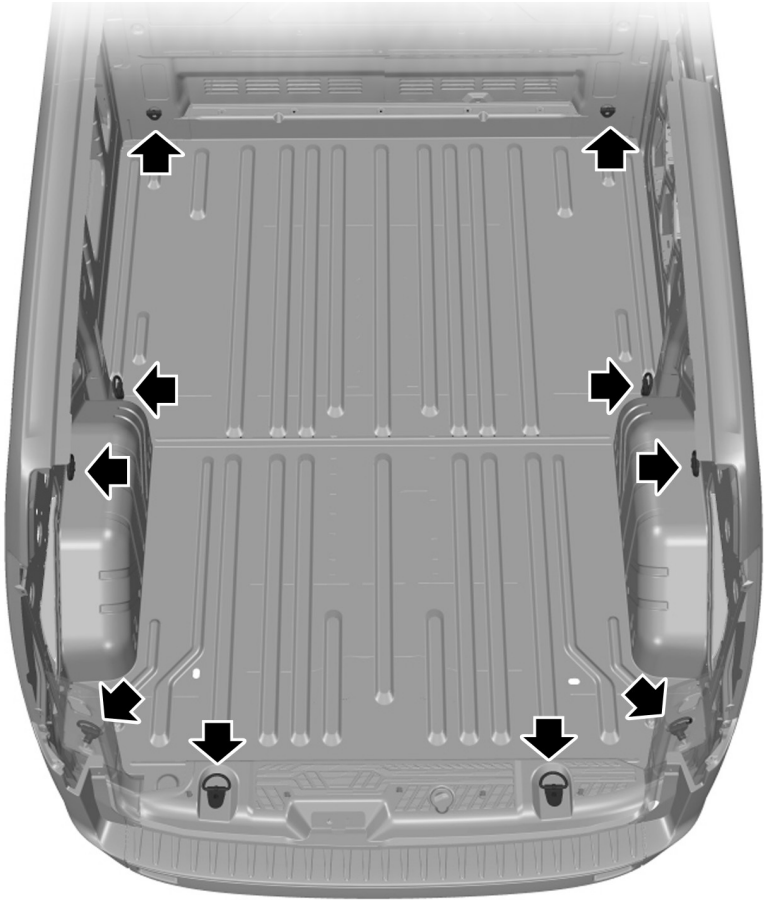

E146219

Towing

TOWING A TRAILER

WARNINGS



Do not exceed 62 mph (100 km/h). This could result in the loss of vehicle control, serious personal injury or death.



Do not exceed the maximum gross train weight stated on your vehicle identification plate. This could result in the loss of vehicle control, serious personal injury or death. See **Vehicle Identification Plate** (page 204).



Do not exceed the maximum permissible trailer nose weight (vertical weight on the tow ball) as stated in the vehicle specification chart. This could result in the loss of vehicle control, serious personal injury or death.



The anti-lock braking system does not control the overrun brake on the trailer. This could result in the loss of vehicle control, serious personal injury or death.

When towing a trailer:

- Obey country specific regulations for towing a trailer.
- Do not exceed 62 mph (100 km/h) even if a country allows higher speeds under certain conditions.
- Place loads as low as possible and central to the axle of your trailer. If you are towing with an unladen vehicle, the load in your trailer should be placed toward the nose, within the maximum nose load, as this gives the best stability.
- The trailer nose weight (vertical weight on the tow ball), is essential for the driving stability of your vehicle and trailer.

- The vertical weight on the tow ball should be at least 4% of the trailer weight and not exceed the maximum permissible weight.
- Reduce speed immediately if the trailer shows any sign of swaying. See **Trailer Sway Control** (page 133).
- Use a low gear when descending a steep downhill gradient.

Note: *The maximum permissible trailer nose weight on the trailer identification plate is the trailer manufacturer's testing value. The vehicle maximum permissible trailer nose weight may be lower.*

The stability of your vehicle to trailer combination is very much dependent on the quality of the trailer.

Towing a trailer changes the vehicle handling characteristics and increases stopping distances. Adapt your speed and driving behavior to the load of the trailer.

The gross train weight stated on the vehicle identification plate applies for road gradients up to 12% and altitudes up to 3281 feet (1000 meters) when towing a trailer. In mountainous regions the engine performance decreases due to lower air density with increasing altitude. In high altitude regions above 3281 feet (1000 metres), the stipulated maximum permitted gross train weight must be reduced by 10% for every extra 3281 feet (1000 metres).

Note: *Not all vehicles are suitable or approved to have tow bars fitted. See an authorized dealer for further information.*

Trailer Lighting

The electrical system on your vehicle is not suitable for towing trailers with LED lamps.

Towing

TRAILER SWAY CONTROL

Note: This feature does not prevent trailer sway, but reduces it once it begins.

Note: This feature cannot stop all trailers from swaying.

Note: In some cases, if your vehicle speed is too high, the system may turn on multiple times, gradually reducing your vehicle speed.

This feature applies your vehicle brakes at individual wheels and if necessary, reduces engine power. If the trailer begins to sway, the traction control warning lamp flashes and a message will appear in the information display. Slow your vehicle down, pull safely to the side of the road and check for correct load distribution. See **Load Carrying** (page 130).

TOWING POINTS

WARNING



The recovery hook has a left-hand thread. Turn it counterclockwise to install it. Make sure that it is fully tightened. Failure to do so could result in the recovery hook becoming loose.

Front Towing Point



E146426

Remove the cover and install the recovery hook.

Rear Towing Point

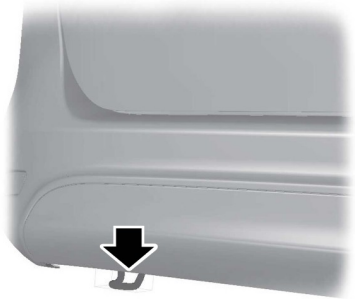

E142319

Note: If your vehicle has a tow bar, use this to tow other vehicles instead of the recovery hook.

Recovery Hook Location

You must carry the recovery hook in your vehicle at all times.



E171163

Towing

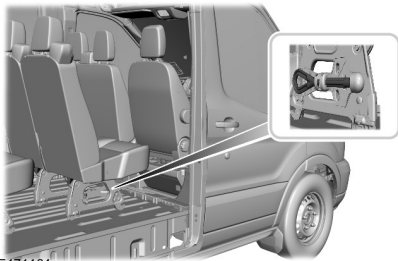





E171164

The recovery hook is located on the side of the first row rear seat or under the front passenger seat. See **Under Seat Storage** (page 92).

TOWING THE VEHICLE ON FOUR WHEELS

WARNINGS

-  You must switch the ignition on when your vehicle is being towed.
-  The brake and steering assistance will not operate unless the engine is running. Press the brake pedal harder and allow for increased stopping distances and heavier steering.
-  Too much tension in the tow rope could cause damage to your vehicle or the vehicle that is towing.
-  Do not use a rigid tow bar on the front towing eye.
-  When towing your vehicle you must select neutral.

Drive off slowly and smoothly without jerking the vehicle you are towing.

Driving Hints

BREAKING-IN

Tires

WARNING



New tires need to be run-in for approximately 300 miles (500 kilometers). During this time, you may experience different driving characteristics.

Brakes and Clutch

WARNING



Avoid heavy use of the brakes and clutch if possible for the first 100 miles (150 kilometers) in town and for the first 1000 miles (1500 kilometers) on freeways.

Engine

WARNING



Avoid driving too fast during the first 1000 miles (1500 kilometers). Vary your speed frequently and change up through the gears early. Do not labor the engine.

REDUCED ENGINE PERFORMANCE

WARNING



Continued operation will increase the engine temperature and cause the engine to shut down completely.

If the engine coolant temperature gauge needle moves to the upper limit position, the engine is overheating. See **Gauges** (page 56).

You must only drive your vehicle for a short distance if the engine overheats. The distance you can travel depends on ambient temperature, vehicle load and terrain. The engine will continue to operate with limited power for a short time.

If the engine temperature continues to rise, the fuel supply to the engine will reduce. The air conditioning will switch off and the engine cooling fan will operate continually.

1. Reduce your speed gradually and stop your vehicle as soon as it is safe to do so.
2. Switch the engine off immediately to prevent severe engine damage.
3. Wait for the engine to cool down.
4. Check the coolant level. See **Engine Coolant Check** (page 157).
5. Have your vehicle checked by an authorized dealer as soon as possible.

ECONOMICAL DRIVING

The following will help to improve fuel consumption.

Tire Pressures

Check your tire pressures regularly to optimize fuel economy. For best results use the economy pressures. See **Technical Specifications** (page 190).

Gear Shifting

Use the highest drivable gear appropriate for the road conditions.

Anticipation

Adjust your vehicle speed and the distance to other vehicles without the need for heavy braking or acceleration.

Driving Hints

Efficient Speed

Higher speeds use more fuel. Reduce your cruising speed on open roads.

Accessories

Try not to add unnecessary accessories to the exterior of your vehicle. If you use a roof rack, remember to fold it down or remove it when not in use.

Electrical Systems

Switch off all electrical systems when not in use, for example air conditioning. Make sure you unplug any accessories from the auxiliary power points when not in use.

COLD WEATHER PRECAUTIONS

The functional operation of some components and systems can be affected at temperatures below -13°F (-25°C).

DRIVING THROUGH WATER

WARNINGS



Drive through water in an emergency only and not as part of normal driving.



Engine damage can occur if water enters the air filter.

In an emergency, you can drive your vehicle through water to a maximum depth of 8 inches (200 millimeters) and at a maximum speed of 6 mph (10 km/h). You must take extra care when driving through flowing water.

When driving in water, maintain a low speed and do not stop your vehicle. After driving through water and as soon as it is safe to do so:

- Depress the brake pedal lightly to check that the brakes are functioning correctly.
- Check that the horn works.
- Check that your vehicle's lamps are fully operational.
- Check the power assistance of the steering system.

FLOOR MATS



E142666

WARNINGS



Always use floor mats that are designed to fit the foot well of your vehicle, leaving the pedal area unobstructed, and which can be firmly secured to retention posts so that they cannot slip out of position and interfere with the pedals or impair safe operation of your vehicle in other ways.



Incorrectly fitted floor mats can cause the accelerator pedal to become stuck in the open position. This can cause loss of vehicle control.



Always correctly install the floor mats to the retention posts so that they cannot slip out of position or obstruct pedal operation.

Driving Hints

WARNINGS



Do not place unsecured floor mats or any other covering in the foot well.



Do not place additional floor mats or any other covering on top of the original floor mats. This will reduce the pedal clearance and interfere with the pedal operation.



Do not allow objects to fall or become trapped under the pedals of your vehicle. This can cause loss of vehicle control.



Carry out regular inspections to make sure the floor mats are secure.

To install the floor mats, position the floor mat eyelet over the retention post and press down to lock in position.

Remove in reverse order.

Roadside Emergencies

HAZARD WARNING FLASHERS



The hazard warning button is located on the instrument panel. Use it when your vehicle is creating a safety hazard for other motorists.

Press the button to turn on the hazard warning function, and the front and rear direction indicators will flash.

Press the button again to turn them off.

Note: *If used when the engine is not running, the battery will lose charge. There may be insufficient power to restart your engine.*

Note: *Depending on applicable laws and regulations in the country for which your vehicle was originally built, the hazard warning flashers may flash if you brake heavily.*

FIRST AID KIT

Space is provided in the passenger's side lower door bin.

WARNING TRIANGLE

Space is provided in the driver's side lower door bin.

EMERGENCY EXIT

WARNING



Make sure that the roof rack and its load do not obstruct the emergency exit. Ask your dealer for advice on roof racks suitable for your vehicle.

Break the glass with the hammer in an emergency.

FUEL SHUTOFF

WARNING



Failure to inspect and if necessary repair fuel leaks after a crash may increase the risk of fire and serious injury. We recommend that the fuel system be inspected by an authorized dealer after any crash.

In the event of a moderate to severe crash, your vehicle is equipped with a fuel pump shut-off feature that stops the flow of fuel to the engine. Not every impact will cause a shut-off.

Should the engine turn off after a crash, you may restart the engine by doing the following:

1. Switch the ignition off.
2. Switch the ignition to position III.
3. Switch the ignition off.
4. Switch the ignition on again to re-enable the fuel pump.

JUMP STARTING THE VEHICLE

WARNINGS



Do not use fuel lines, engine rocker covers or the intake manifold as grounding points.



Connect batteries with only the same nominal voltage.



Always use booster cables with insulated clamps and adequate size cable.

Note: *Do not disconnect the battery.*

Roadside Emergencies

To Connect the Booster Cables

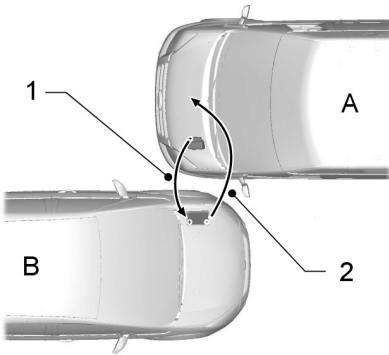

E75524

- A Flat battery vehicle
- B Booster battery vehicle
- 1 Positive connection cable
- 2 Negative connection cable

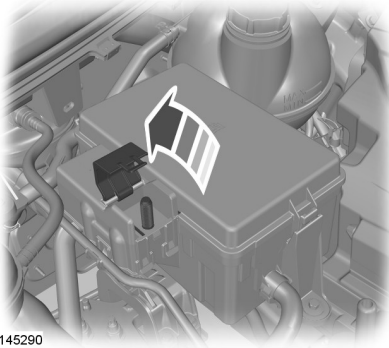

E145290

1. Position the vehicles so that they do not touch one another.
2. Switch the ignition off and any electrical equipment.

3. Lift up the battery positive connection point cover. For item location, refer to the appropriate under hood overview. See **Maintenance** (page 153).
4. Connect the positive (+) terminal of vehicle B with the positive (+) terminal of vehicle A (cable 1).

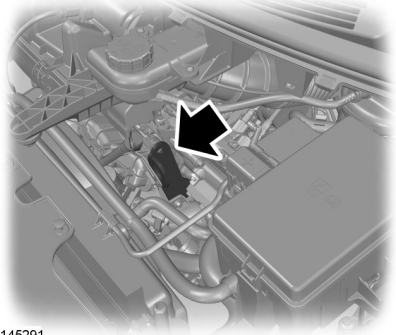

E145291

5. Connect the negative (-) terminal of vehicle B to the engine block or the engine lifting eye of vehicle A (cable 2).

WARNINGS



Do not connect directly to the negative (-) terminal of the flat battery.



Make sure that the cables are clear of any moving parts and fuel delivery system parts.

To Start the Engine

1. Run the engine of vehicle B at a moderately high speed.
2. Start the engine of vehicle A.
3. Run both vehicles for a minimum of three minutes before disconnecting the cables.

Roadside Emergencies

WARNING



Do not switch the headlamps on when disconnecting the cables. The peak voltage could blow the bulbs.

Disconnect the cables in the reverse order.

Fuses

FUSE BOX LOCATIONS

Engine Compartment Fuse Box

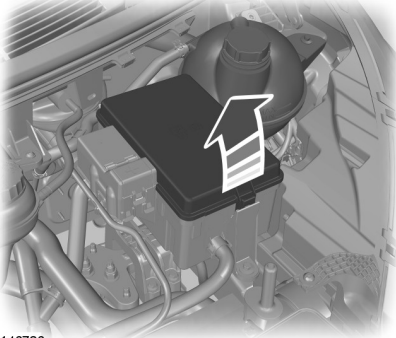

E146726

For item location: See **Under Hood Overview** (page 154).

Passenger Compartment Fuse Box

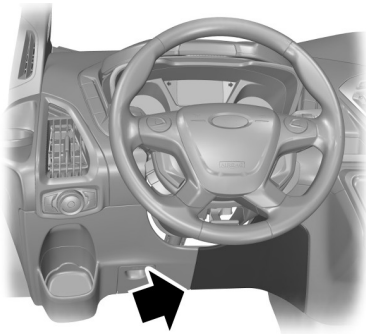

E152513

This is located behind the removable trim panel.

Pre-fuse Box

This is located under the driver's seat.

Body Control Module Fuse Box



E152512

This is located behind the removable trim panel.

Fuses

FUSE SPECIFICATION CHART

Engine Compartment Fuse Box

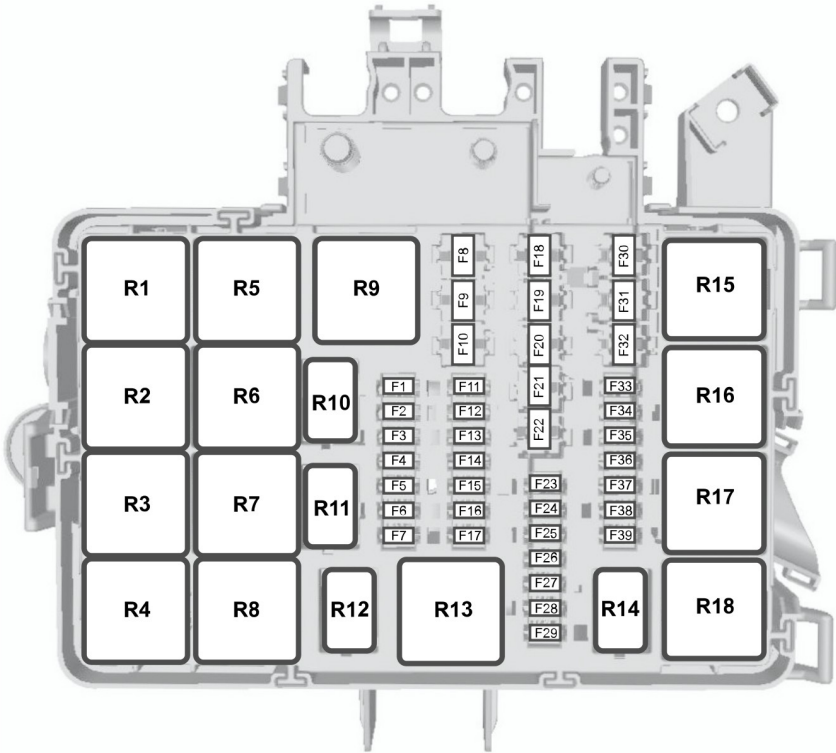

E148826

Fuse	Fuse rating	Circuits protected
F1	10A	Selective Catalytic Reduction.
F2	15A	Selective Catalytic Reduction.
F3	15A	Selective Catalytic Reduction.
F4	10A	Selective Catalytic Reduction.

Fuses

Fuse	Fuse rating	Circuits protected
F5	3A	Diesel particulate filter vaporizer. Glow plug monitor.
F6	3A	Anti-lock brake system. Stability assist. Ignition.
F7	7.5A	Powertrain control module.
F8	20A	Cooling fan.
F9	30A	Left-hand windshield wiper.
F10	30A	Right-hand windshield wiper.
F11	10A	Air conditioning clutch.
F12	20A	Diesel particulate filter vaporizer glow plug.
F13	-	Not used.
F14	3A	Selective Catalytic Reduction - ignition.
F15	-	Not used.
F16	-	Not used.
F17	-	Not used.
F18	40A	Anti-lock brake system. Stability assist pump.
F19	30A	Starter solenoid.
F20	60A	Glow plugs.
F21	60A	Ignition relay 3.
F22	-	Not used.
F22	-	Not used.
F23	-	Not used.
F24	7.5A	Fuel injection pump.
F25	-	Not used.
F26	-	Not used.
F27	-	Not used.

Fuses

Fuse	Fuse rating	Circuits protected
F28	-	Not used.
F29	-	Not used.
F30	40A	Cooling fan 1.
F31	40A	Cooling fan 2.
F32	60A	Windshield dual wiper motors.
F33	20A	Start-Stop auxiliary water pump.
F34	-	Not used.
F35	15A	Powertrain control system supply.
F36	15A	Sensor NOXI 2.
F37	7.5A	Volume Control Valve.
F38	7.5A	Mass air flow sensor.
F39	15A	Diesel pump vaporizer.

Relay	Circuits switched
R1	Ignition.
R2	Starter motor.
R3	Rear window wiper.
R4	Not used.
R5	Cooling fan.
R6	Windshield wiper - on and off.
R7	Windshield wiper - low and high speed.
R8	Not used.
R9	Not used.
R10	Air conditioning clutch.
R11	Fuel vaporizer system glow plug.
R12	Fuel injection pump.
R13	All-wheel drive pump.

Fuses

Relay	Circuits switched
R14	Econetic.
R15	Low and high speed cooling fan.
R16	Selective Catalytic Reduction.
R17	Powertrain control module.
R18	High speed cooling fan.

Passenger Compartment Fuse panel

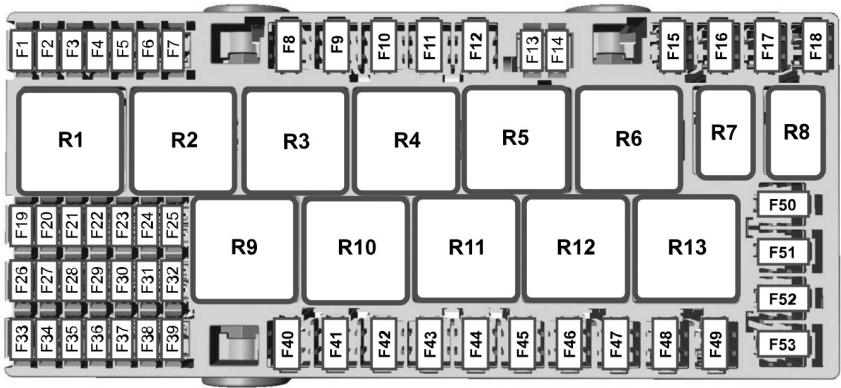

E148827

Fuse	Fuse rating	Circuits protected
F1	10A	Airbag module.
F2	20A	Heated rear window.
F3	10A	Heated exterior mirrors.
F4	-	Not used.
F5	-	Not used.
F6	5A	Tachograph.
F7	10A	Battery sensor.

Fuses

Fuse	Fuse rating	Circuits protected
F8	40A	AC power outlet socket.
F9	-	Not used.
F10	30A	Driver power seat.
F11	30A	Passenger power seat.
F12	30A	Power step.
F13	-	Not used.
F14	5A	Tracking and blocking control module.
F15	40A	Powertrain control module battery relay.
F16	40A	Powertrain control module power relay.
F17	-	Not used.
F18	30A	Anti-lock brake system valves. Stability assist valves.
F19	5A	Tachograph.
F20	5A	Heated exterior mirror relay. Heated windshield relay.
F21	-	Not used.
F22	15A	Passenger compartment fuse panel.
F23	7.5A	Air conditioning control module.
F24	5A	Headlamp leveling.
F25	7.5A	Interior lighting.
F26	10A	Heated exterior mirrors.
F27	20A	Heated front seats.
F28	20A	Cornering lamps.
F29	10A	Rear parking aid camera. Lane keeping system. Electro mirror.
F30	5A	Adaptive cruise control.
F31	-	Not used.

Fuses

Fuse	Fuse rating	Circuits protected
F32	10A	Interior lighting.
F33	20A	All wheel drive module.
F34	20A	Rear window wiper.
F35	5A	Power folding mirrors.
F36	20A	Horn.
F37	7.5A	SYNC module.
F38	5A	Blower motor. Horn relay. Windshield wiper relay.
F39	7.5A	Remote keyless entry. Battery. Power windows. Rear heating, ventilation and air conditioning.
F40	40A	Front blower motor.
F41	40A	Rear blower motor.
F42	30A	Heated rear window.
F43	30A	Trailer socket.
F44	60A	Auxiliary power points.
F45	-	Not used.
F46	30A	Power windows.
F47	20A	Cigar lighter socket.
F48	20A	Rear auxiliary power points.
F49	20A	Front auxiliary power points.
F50	60A	Ignition relay 1.
F51	60A	Ignition relay 2.
F52	40A	Left-hand heated windshield element.
F53	40A	Right-hand heated windshield element.

Fuses

Relay	Circuits switched
R1	Fuel fired booster heater.
R2	Auxiliary power points.
R3	Not used.
R4	Ignition 2.
R5	Power windows.
R6	Ignition 1.
R7	Horn.
R8	Not used.
R9	Front blower motor.
R10	Rear blower motor.
R11	Heated rear window. Heated exterior mirrors.
R12	Left-hand heated windshield element.
R13	Right-hand heated windshield element.

Pre-fuse Box

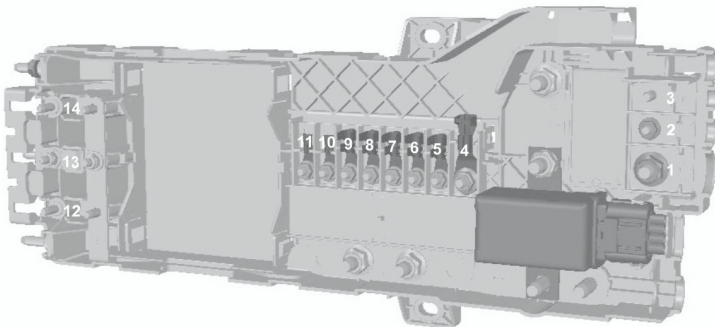

E148828

Fuses

Fuse	Fuse rating	Circuits protected
F1	470A	Engine compartment fuse box. Starter motor. Alternator.
F2	100A	Passenger compartment fuse panel. Body control module fuse box.
F3	40A	Powertrain control module. Anti-lock brake system.
F4	200A	Passenger compartment fuse panel.
F5	100A	Passenger compartment fuse panel.
F6	80A	Cabin heater.
F7	80A	Heated windshield.
F8	100A	Engine junction box.
F9	100A	Passenger compartment fuse panel.
F10	60A	Passenger compartment fuse panel supply.
F11	60A	Passenger compartment fuse panel supply.
F12	60A	Auxiliary power point 1.
F13	60A	Auxiliary power point 2.
F14	60A	Auxiliary power point 3.

Fuses

Body Control Module Fuse Box

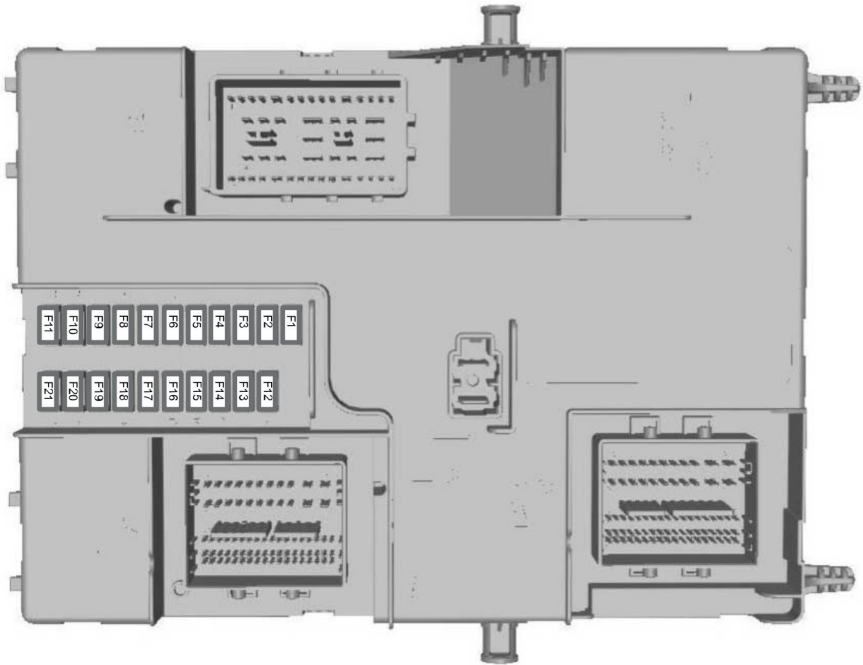

E148830

Fuse	Fuse rating	Circuits protected
F1	15A	Central locking system 2.
F2	15A	Central locking system 1.
F3	15A	Ignition switch.
F4	5A	Parking assist control module.
F5	5A	Rain sensor module.
F6	15A	Windshield washer pump.
F7	7.5A	Exterior mirrors.

Fuses

Fuse	Fuse rating	Circuits protected
F8	15A	Front fog lamps.
F9	10A	Right-hand high beam.
F10	10A	Left-hand high beam.
F11	25A	Right-hand exterior lamps. Left-hand side lamps.
F12	20A	Battery backup sounder. Anti-theft alarm horn.
F13	15A	On-board diagnostic. Battery saver.
F14	25A	Turn signal indicator.
F15	25A	Left-hand exterior lamps. Right-hand side lamp. Central high mounted brake lamp.
F16	20A	Audio unit. Navigation unit.
F17	7.5A	Instrument panel cluster. Heater control.
F18	10A	Headlamp switch module. Steering wheel module.
F19	5A	Front control/display interface module.
F20	5A	Ignition passive anti-theft system.
F21	3A	Accessory relay.

CHANGING A FUSE

WARNINGS



Do not modify the electrical system of your vehicle in any way. Have repairs to the electrical system and the replacement of relays and high current fuses carried out by an authorized dealer.



Switch the ignition and all electrical equipment off before attempting to change a fuse.

WARNINGS



Always replace a fuse with one that has the specified amperage rating. Using a fuse with a higher amperage rating can cause severe wire damage and could start a fire.

Fuses

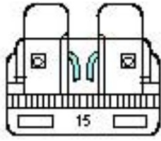

E142430

If electrical components in your vehicle are not working, a fuse may have blown. A break in the fuse wire will indicate a blown fuse. Check the appropriate fuses before replacing any electrical components.

Maintenance

GENERAL INFORMATION

Have your vehicle serviced regularly to help maintain its roadworthiness and resale value. There is a large network of Ford authorized repairers that are there to help you with their professional servicing expertise. Authorized repairers are best qualified to service your vehicle properly and expertly, with a wide range of highly specialized tools.

In addition to regular servicing, we recommend that you carry out the following checks.

WARNINGS



Switch the ignition off before touching or attempting adjustment of any kind.



Do not touch the electronic ignition system parts after you have switched the ignition on or when the engine is running. The system operates at high voltage.



Keep your hands and clothing clear of the engine cooling fan. Under certain conditions, the fan may continue to run for several minutes after you have switched the engine off.



Make sure that you fit filler caps securely after carrying out maintenance checks.

Daily Checks

- Exterior lamps.
- Interior lamps.
- Warning lamps and indicators.

Check When Refueling

- Engine oil level. See **Engine Oil Check** (page 156).
- Brake fluid level. See **Brake and Clutch Fluid Check** (page 157).

- Washer fluid level. See **Washer Fluid Check** (page 158).
- Tire pressures (when cold). See **Technical Specifications** (page 179).
- Tire condition. See **Wheels and Tires** (page 176).

Monthly Checks

- Engine coolant level (engine cold). See **Engine Coolant Check** (page 157).
- Pipes, hoses and reservoirs for leaks.
- Air conditioning operation.
- Parking brake operation.
- Horn operation.
- Tightness of lug nuts. See **Technical Specifications** (page 179).

OPENING AND CLOSING THE HOOD

Opening the Hood

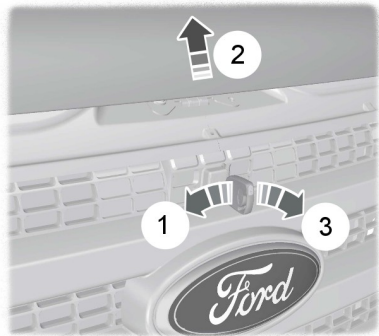

E72108

1. Insert the vehicle key into the hood lock and turn counterclockwise.
2. Slightly lift the hood.
3. Turn the key clockwise to release the hood.

Maintenance

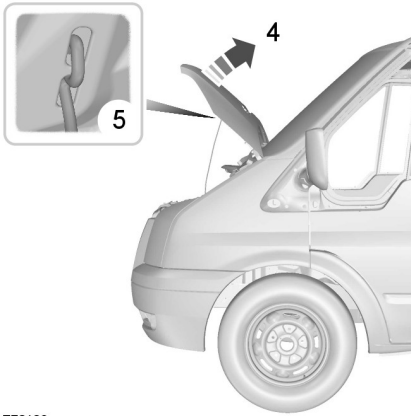

4. Open the hood.
5. Support the hood with the hood strut.

Closing the Hood

1. Remove the hood strut from the catch and secure it correctly in the clip.
2. Lower the hood and allow it to drop under its own weight for the last 8-12 in (20-30 cm).

Note: Make sure that the hood is correctly closed.

E72109

UNDER HOOD OVERVIEW - FWD

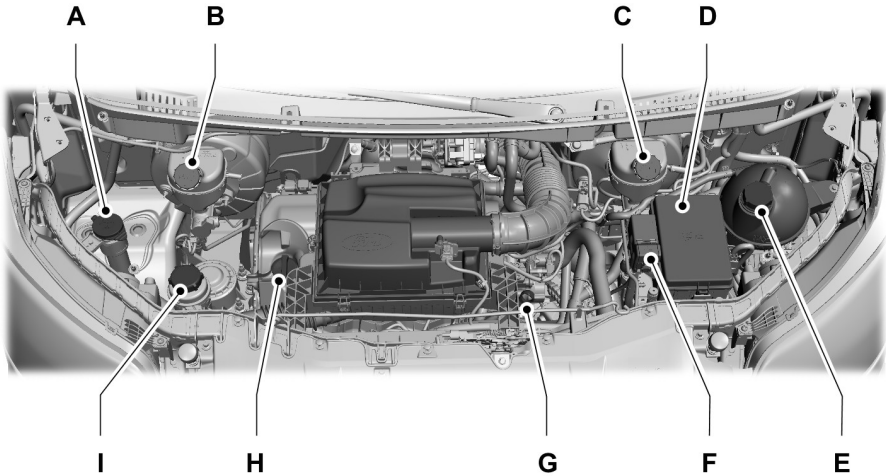

E174213

Maintenance

- A Washer fluid reservoir*. See **Washer Fluid Check** (page 158).
- B Brake and clutch fluid reservoir (right-hand drive). See **Brake and Clutch Fluid Check** (page 157).
- C Brake and clutch fluid reservoir (left-hand drive). See **Brake and Clutch Fluid Check** (page 157).
- D Engine junction box. See **Fuses** (page 141).
- E Engine coolant reservoir. See **Engine Coolant Check** (page 157).
- F Battery positive connection (for connecting booster cables). See **Jump Starting the Vehicle** (page 138).
- G Engine oil dipstick*. See **Engine Oil Check** (page 156).
- H Engine oil filler cap. See **Engine Oil Check** (page 156).
- I Power steering fluid reservoir. See **Power Steering Fluid Check** (page 158).

* The filler caps and the engine oil dipstick are colored for easy identification.

UNDER HOOD OVERVIEW - AWD/RWD

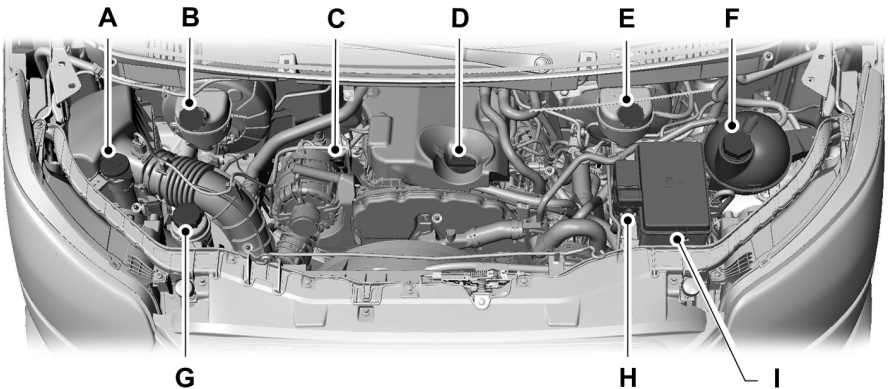

E169967

- A Windshield washer reservoir*. See **Washer Fluid Check** (page 158).
- B Brake and clutch fluid reservoir (right-hand drive). See **Brake and Clutch Fluid Check** (page 157).

Maintenance

- C Engine oil dipstick*. See **Engine Oil Check** (page 156).
- D Engine oil filler cap. See **Engine Oil Check** (page 156).
- E Brake and clutch fluid reservoir (left-hand drive). See **Brake and Clutch Fluid Check** (page 157).
- F Engine coolant reservoir. See **Engine Coolant Check** (page 157).
- G Power steering fluid reservoir. See **Power Steering Fluid Check** (page 158).
- H Battery positive connection (for connecting booster cables). See **Jump Starting the Vehicle** (page 138).
- I Engine compartment fuse box. See **Fuses** (page 141).

* The filler caps and the engine oil dipstick are colored for easy identification.

ENGINE OIL DIPSTICK

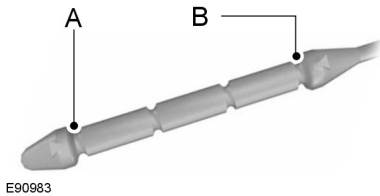

- A Minimum
- B Maximum

ENGINE OIL CHECK

1. Make sure that your vehicle is on level ground.
2. Switch off the engine and wait 10 minutes for the oil to drain into the oil pan.
3. Remove the dipstick and wipe it with a clean, lint free cloth. Replace the dipstick and remove it again to check the oil level.

If the oil level is at the minimum mark, add oil immediately. See **Technical Specifications** (page 170).

Note: Check the oil level before starting the engine.

Note: Make sure that the oil level is between the minimum and the maximum marks.

Note: Do not use oil additives or other engine treatments. Under certain conditions, they could damage the engine.

Note: The oil consumption of new engines reaches its normal level after approximately 3000 mi (5,000 km).

Adding Engine Oil

WARNINGS



Only add oil when the engine is cold. If the engine is hot, wait 10 minutes for the engine to cool down.



Do not remove the filler cap when the engine is running.

1. Remove the engine oil filler cap.
2. Add engine oil that meets Ford specifications. See **Technical Specifications** (page 170).
3. Replace the engine oil filler cap. Turn it until you feel a strong resistance.

Maintenance

Note: Do not add oil further than the maximum mark. Oil levels above the maximum mark may cause engine damage.

Note: Soak up any spillage with an absorbent cloth immediately.

ENGINE COOLANT CHECK

WARNINGS



Never remove the coolant reservoir cap while the engine is running or hot.



Only add coolant when the engine is cold. If the engine is hot, wait 10 minutes for the engine to cool down.



Do not allow the fluid to touch your skin or eyes. If this happens, rinse the affected areas immediately with plenty of water and contact your physician.



Undiluted coolant is flammable and may ignite if spilt on a hot exhaust.



E169064

Make sure that the coolant level is between the **MIN** and the **MAX** marks. If the coolant level is on or below the **MIN** mark, add coolant meets the correct specification immediately. See **Technical Specifications** (page 170).

Note: Coolant expands when it is hot. The level may therefore extend beyond the **MAX** mark.

Adding Engine Coolant

1. Remove the filler cap.
2. Add engine coolant to the **MAX** mark, do not overfill.
3. Replace the filler cap. Turn it until you feel a strong resistance.

Note: Add a 50/50 mixture of antifreeze and water, or prediluted engine coolant that meets the correct specification. See **Technical Specifications** (page 170).

Note: In an emergency you can add just water to the cooling system to reach a vehicle service station.

Note: Prolonged use of an incorrect dilution of engine coolant can cause engine damage, for example corrosion, overheating or freezing.

BRAKE AND CLUTCH FLUID CHECK

WARNINGS



Do not use any fluid other than the recommended brake fluid as this will reduce brake efficiency. Use of incorrect fluid could result in the loss of vehicle control, serious personal injury or death.



Only use brake fluid from a sealed container. Contamination with dirt, water, petroleum products or other materials may result in brake system damage or failure. Failure to adhere to this warning could result in the loss of vehicle control, serious personal injury or death.



Do not allow the fluid to touch your skin or eyes. This could cause serious personal injury. Rinse the affected areas immediately with plenty of water and consult a physician.

Maintenance

WARNINGS



A fluid level between the **MAX** and **MIN** lines is within the normal operating range and there is no need to add fluid. A fluid level outside of the normal operating range could compromise the performance of the brake or clutch systems. Have your vehicle checked immediately.



E 169063

See **Technical Specifications** (page 170).

Note: *The brake and the clutch systems are supplied from the same reservoir.*

POWER STEERING FLUID CHECK

WARNING



Do not allow the fluid to touch your skin or eyes. This could cause serious personal injury. Rinse the affected areas immediately with plenty of water and consult a physician.

If the power steering fluid level is between the **MAX** and **MIN** marks add power steering fluid that meets the correct specification. See **Technical Specifications** (page 170).

Adding Power Steering Fluid

1. Remove the filler cap.
2. Add power steering fluid to the **MAX** mark. Do not overfill.
3. Replace the filler cap. Turn it until you feel a strong resistance.

WASHER FLUID CHECK

Note: *The reservoir supplies the front and rear washer systems.*

When adding fluid, use a mixture of washer fluid and water to help prevent freezing in cold weather and improve the cleaning capability. We recommend that you use only high quality washer fluid.

For information on fluid dilution, refer to the product instructions.

DRAINING THE FUEL FILTER WATER TRAP

WARNING



Do not dispose of fuel in the household refuse or the public sewage system. Use an authorized waste disposal facility.

Maintenance

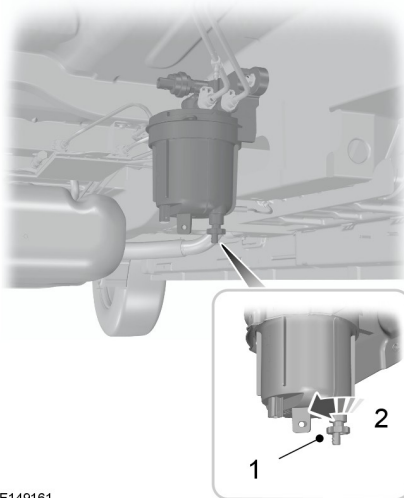

E149161

1. Attach a tube to the drain plug and place the end of the tube into a suitable container.
2. Loosen the drain plug one to two turns and allow the water to drain.
3. Tighten the drain plug until you feel a strong resistance.

Note: The drain plug will rise while opening.

Note: To drain the fuel filter water trap you will need to access the underside of your vehicle.

Note: Only add fuel that meets the Ford specification. See **Fuel and Refueling** (page 99).





With the engine running the water in fuel indicator lamp will go out after approximately two seconds.

CHANGING THE 12V BATTERY

Removing the Battery

WARNINGS

-  You must replace your vehicle battery with one of exactly the same specification.
-  Make sure the battery box is correctly sealed.
-  Your vehicle battery is heavy; take care when lifting and removing.

Note: If you have power seats and the battery has no charge, jump-start your vehicle to move the seat. See **Jump Starting the Vehicle** (page 138).

Note: Where applicable you must reprogram the audio system using the keycode.

The battery is located inside your vehicle under the driver's seat.

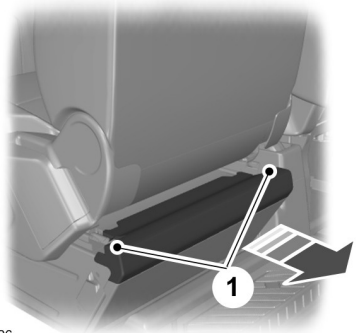

E152526

1. Remove the cover trim by pulling up the tabs with your fingers.

Maintenance

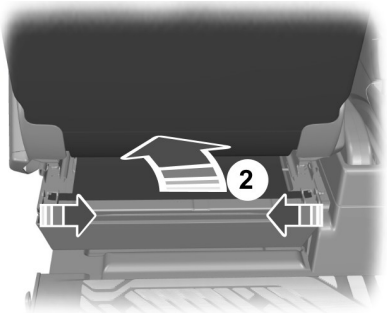

E152529

2. Unhook the cover flap and tuck it under the seat valance.

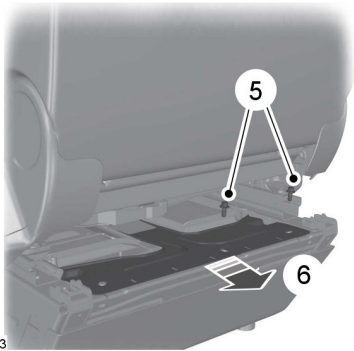

E146773

5. Remove the battery clamp bolts.
6. Remove the battery clamp and cover.

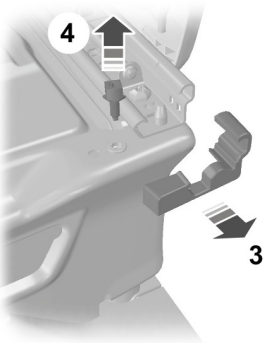

E146781

3. Remove the cover on both sides.
4. Remove the seat runner bolts on both sides. Slide the seat fully forward, making sure the arm rest is folded up. See **Seats** (page 81).

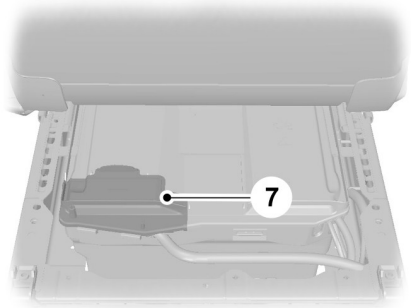

E162774

7. Remove the battery terminal cover.

Maintenance

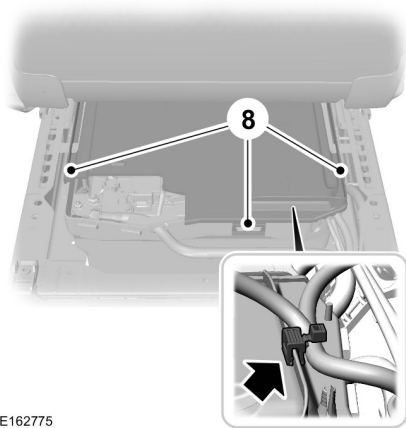

E162775

8. Remove the cable securing clips from the cover. Release the retaining clips and remove the cover.

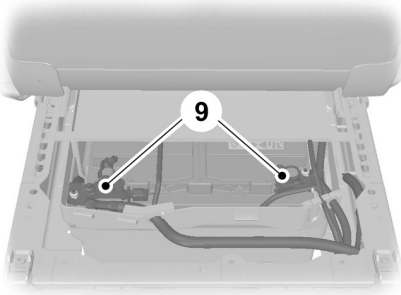

E162776

9. Disconnect the battery.

Installing the Battery

WARNING



Make sure that you securely fasten the seat runner bolts before installing the covers.

Install in the reverse order.

CHECKING THE WIPER BLADES



E142463

Run the tip of your fingers over the edge of the blade to check for roughness.

Clean the wiper blades with washer fluid or water applied with a soft sponge or cloth.

CHANGING THE WIPER BLADES

Changing the Windshield Wiper Blades

Lift the wiper arm.

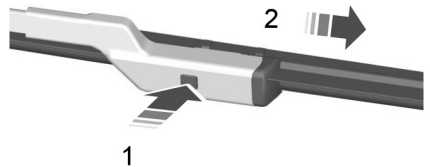

E72899

1. Press the locking button.
2. Remove the wiper blade.
3. Install in the reverse order. Make sure that the wiper blade locks into place.

Maintenance

Note: The windshield wiper blades are different in length. If you install wiper blades of the wrong length, the rain sensor may not work correctly.

Changing the Rear Window Wiper Blade

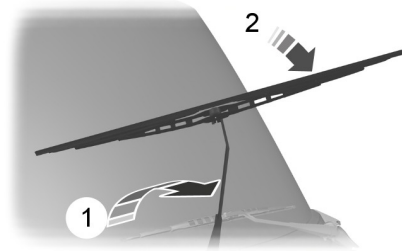

E93783

1. Lift the wiper arm.
2. Position the wiper blade at right angles to the wiper arm.

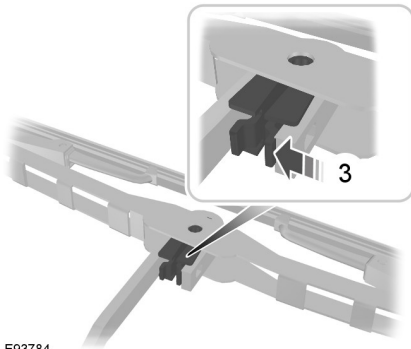

E93784

3. Press the locking lever.

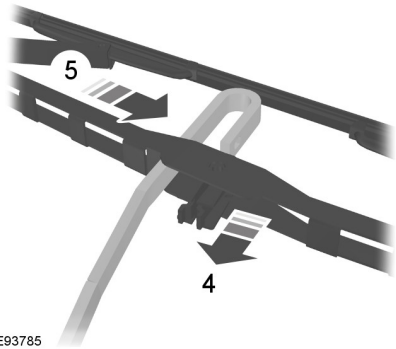

E93785

4. Disengage the wiper blade from the wiper arm.
5. Slide the wiper blade to the side.

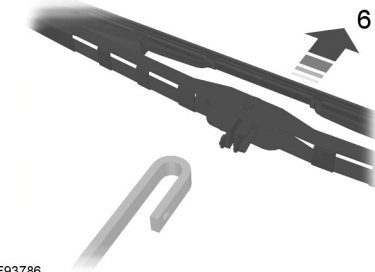

E93786

6. Remove the wiper blade.
7. Install in the reverse order. Make sure that the wiper blade locks into place.

REMOVING A HEADLAMP

WARNING



Switch all of the lamps and the ignition off. Failure to do so could result in serious personal injury.

1. Open the hood. See **Opening and Closing the Hood** (page 153).

Maintenance

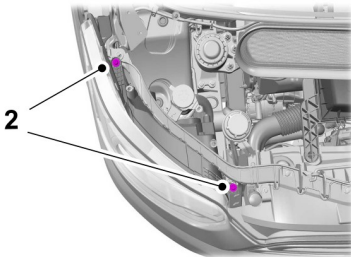

E169198

2. Remove the screws.

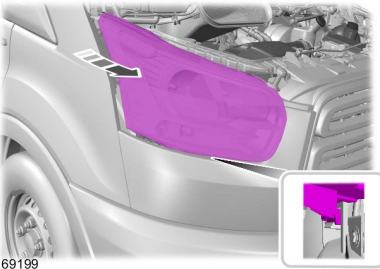

E169199

3. Pull the headlamp toward the front of your vehicle to disengage it from its locating points, and then lift the headlamp up.

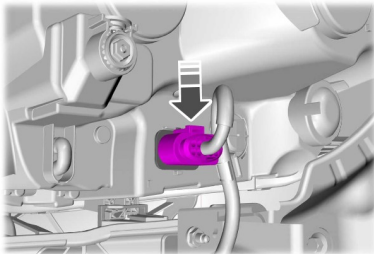

E169200

4. Disconnect the electrical connector.

Note: When you install the headlamp make sure that you attach the electrical connector correctly.

Note: When you install the headlamp make sure that you engage its locating points correctly.

CHANGING A BULB

WARNINGS



Switch all of the lamps and the ignition off. Failure to do so could result in serious personal injury.



Bulbs become hot when in use. Let them cool down before you remove them.

Use the correct specification bulb. See **Bulb Specification Chart** (page 168).

The following instructions describe how to remove the bulbs. Install in the reverse order unless otherwise stated.

Note: LED lamps are not serviceable. See an authorized dealer.

Headlamp

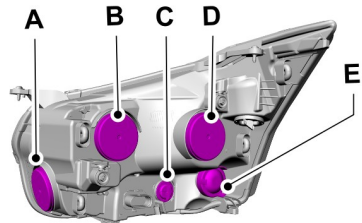

E169204

- A Cornering lamp
- B Daytime running lamp and headlamp high beam
- C Direction indicator
- D Headlamp low beam
- E Side lamp

Maintenance

Note: You may have to remove a cover to gain access to the bulb.

Side Lamp

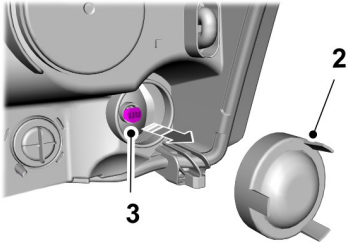

E170405

1. Remove the headlamp. See **Removing a Headlamp** (page 162).
2. Remove the cover.
3. Remove the bulb holder by pulling it straight out. Remove the bulb.

Direction Indicator

Remove the headlamp. See **Removing a Headlamp** (page 162).

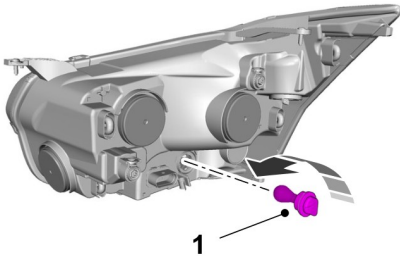

E169205

1. Turn the bulb holder counterclockwise and remove it.
2. Press the bulb in and turn the bulb counterclockwise to remove it.

Headlamp Low Beam

Remove the headlamp. See **Removing a Headlamp** (page 162).

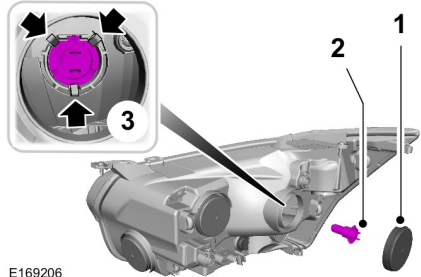

E169206

1. Remove the cover.
2. Disconnect the electrical connector.
3. Pull the bulb straight out past the retaining clips.

Note: Do not touch the glass of the bulb.

Headlamp High Beam

1. Remove the headlamp. See **Removing a Headlamp** (page 162).

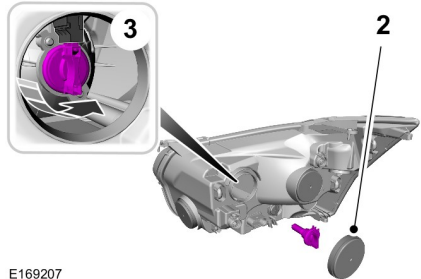

E169207

2. Remove the cover.
3. Turn the bulb counterclockwise and remove it.

Note: Do not touch the glass of the bulb.

Note: You cannot separate the bulb from the bulb holder.

Maintenance

Cornering Lamp

Remove the headlamp. See **Removing a Headlamp** (page 162).

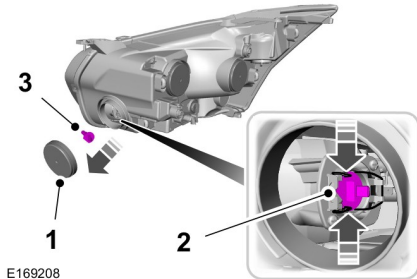

E169208

1. Remove the cover.
2. Disconnect the electrical connector and release the clip.
3. Remove the bulb.

Note: Do not touch the glass of the bulb.

Side Repeater

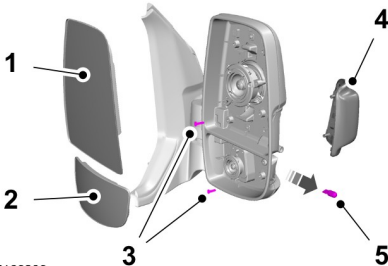

E169209

1. Remove the large mirror glass. Tilt the mirror glass fully up, pull the mirror glass toward you from the bottom.
2. Remove the small mirror glass. Tilt the mirror glass fully down, pull the mirror glass toward you from the top.
3. Remove the screws.
4. Remove the lamp lens.

5. Remove the bulb.

Front Fog Lamps

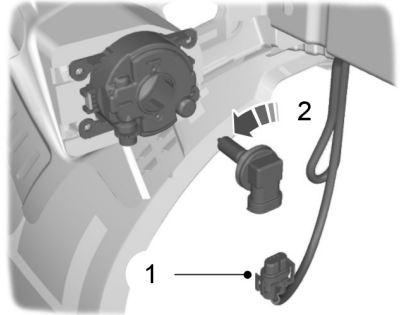

E71062

1. Disconnect the electrical connector.
2. Turn the bulb holder counterclockwise and remove it.

Note: You cannot separate the bulb from the bulb holder.

Maintenance

Rear Lamps

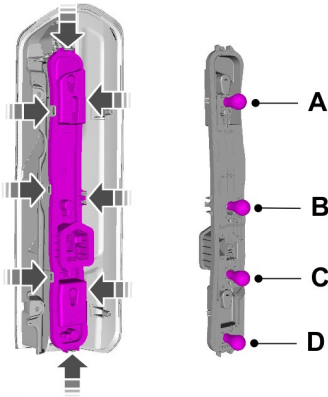
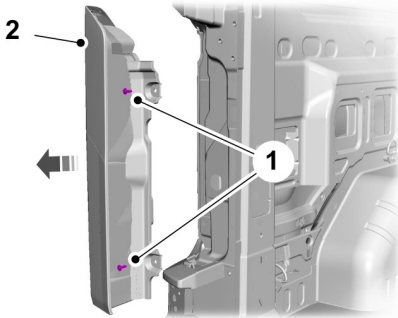

E169210

- A Tail and brake lamp
- B Direction indicator
- C Reversing lamp
- D Fog lamp

1. Remove the screws.
2. Remove the lamp and unclip the bulb holder.
3. Press the bulb in and turn the bulb counterclockwise to remove it.

Central High Mounted Brake Lamp

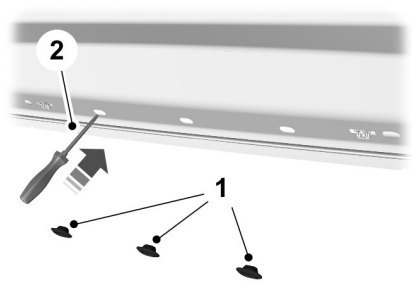

E162641

1. Remove the rubber grommets.
- Note:** *If fitted, remove the trim panel first.*
2. Using a screwdriver, gently prise the clips to release the lamp.

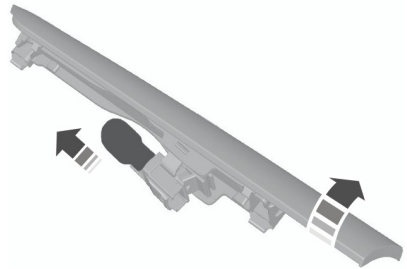

E146638

3. Carefully remove the lamp.
4. Remove the bulb.

Note: *LED lamps are not serviceable. See an authorized dealer.*

Maintenance

License Plate Lamp

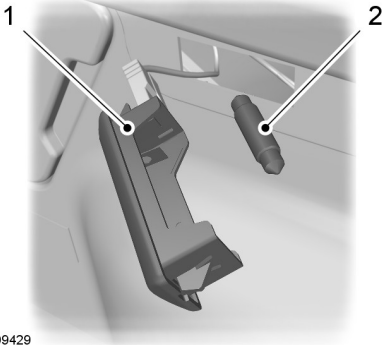

E99429

1. Carefully remove the lamp.
2. Remove the bulb.

Interior Lamp

Entrance Lamps

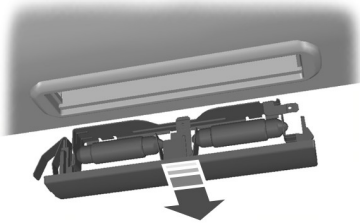

E154369

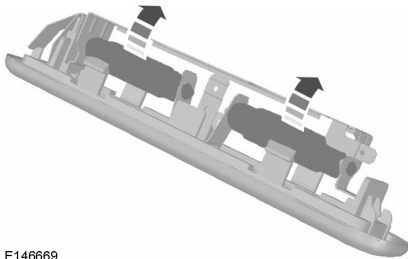

E146669

1. Carefully remove the lamp.
2. Remove the bulbs.

Vehicles with Interior Sensors

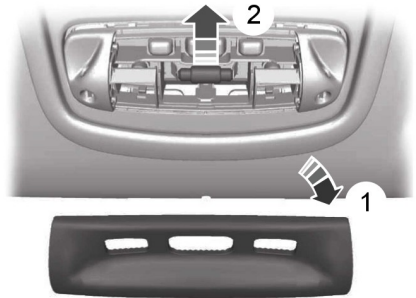

E154370

1. Carefully remove the lens.
2. Remove the bulb.

Reading Lamps

Vehicles with Interior Sensors

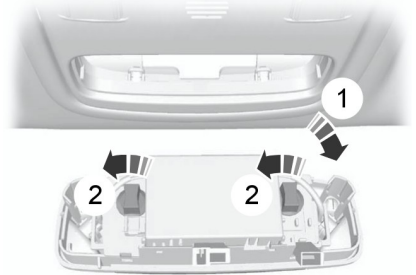

E72786

1. Carefully remove the lamp.
2. Turn the bulb holder counterclockwise and remove it.

Maintenance

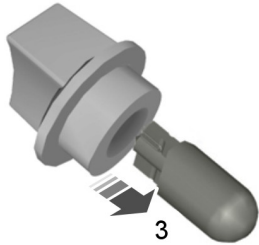

E73939

3. Remove the bulb.

Vehicles without Interior Sensors

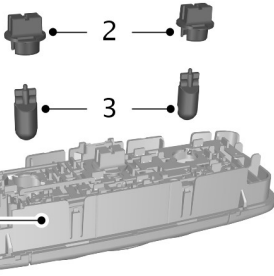

E99453

1. Carefully remove the lamp.
2. Turn the bulb holder counterclockwise and remove it.
3. Remove the bulb.

Sun Visor Mirror Lamp

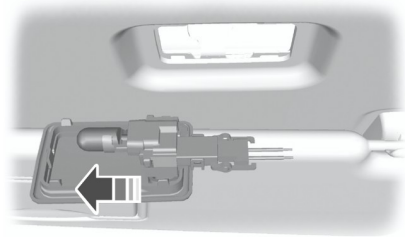

E72785

1. Carefully remove the lamp.
2. Remove the bulb.

BULB SPECIFICATION CHART

Exterior Lamps

Lamp	Specification	Power (watt)
Body side marker lamp	W5W	5
Brake and tail lamp	P21/5W	21/5
Central high mounted brake lamp	W16W	16
Chassis cab rear marker lamp	W5W	5
Cornering lamp	H1	55
Front direction indicator lamp	PY21W	21
Front fog lamp	H11	55

Maintenance

Lamp	Specification	Power (watt)
Front side lamp	W5W	5
High beam headlamp and Daytime running lamp	H15	55/15
License plate lamp	W5W	5
Low beam headlamp	H7	55
Rear direction indicator lamp	PY21W	21
Rear fog lamp	P21W	21
Reversing lamp	P21W	21
Roof outline marker lamp	W5W	5
Side repeater lamp - high watt	W16W	16
Side repeater lamp - low watt	WY5W	5

Note: *If your vehicle is fitted with LED lamps these are not serviceable items, see an authorized dealer if they fail.*

Interior Lamps

Lamp	Specification	Power (watt)
Front interior lamp	W6W	6
Front interior lamp - with category 1 alarm	Festoon	6
Luggage compartment lamp	211 Festoon	10
Map reading lamp	W6W	6
Side door entrance lamp	211 Festoon	10

Note: *If your vehicle is fitted with LED lamps these are not serviceable items, see an authorized dealer if they fail.*

Maintenance

TECHNICAL SPECIFICATIONS - FWD

Capacities

Item	Capacity
Engine cooling system	3.1 gal (14.1 L)
Engine lubrication system - including the oil filter	1.4 gal (6.5 L)
Engine lubrication system - excluding the oil filter	1.4 gal (6.2 L)
Engine oil top-up - raise the level on the dipstick from minimum to maximum	0.4 gal (1.5 L)
Fuel tank - normal capacity	17.6 gal (80 L)
Fuel tank - increased capacity	20.9 gal (95 L)
Diesel exhaust fluid	4.6 gal (21 L)
Windshield and rear window washer system - including headlamp washer	1 gal (4.5 L)

Specifications

Materials

Name	Specification
Engine Oil - 5W-30	WSS-M2C913-C
Transmission Oil - 75W FE 7U7J-M2C200-BA/CA	WSS-M2C200-D2
Automatic Transmission Oil C-ML5 7U7J-M2C938-AB	WSS-M2C938-A
Antifreeze Super Plus Premium 4U7J-19544-xxxx	WSS-M97B44-D
Antifreeze Super Plus Premium Ready Mix 2U2J-19544-xxxx	WSS-M97B44-D2
Brake Fluid DOT 4 LV High Performance BU7J-M6C65-xxxx	WSS-M6C65-A2

Note: *If you are unable to find an engine oil that meets the specification defined, you must use an SAE 5W-30 engine oil defined by ACEA A5/B5 for top-up only.*

Use oil and fluids that meet the defined specification and viscosity grades.

If you use oil and fluids that do not meet the defined specification and viscosity grades this may lead to:

- Component damage which may not be covered by the vehicle Warranty.
- Longer engine cranking periods.
- Increased emission levels.

Maintenance

- Reduced engine performance.
- Reduced fuel economy.
- Degraded brake performance.



We recommend that you use Castrol or Ford engine oil.

TECHNICAL SPECIFICATIONS - RWD

Capacities

Item	Capacity
Engine cooling system	3.1 gal (14 L)
Engine lubrication system - including the oil filter	2.2 gal (10.1 L)
Engine lubrication system - excluding the oil filter	2.1 gal (9.7 L)
Engine oil top-up - raise the level on the dipstick from minimum to maximum	0.4 gal (2 L)
Fuel tank - normal capacity	17.6 gal (80 L)
Fuel tank - increased capacity	20.9 gal (95 L)
Diesel exhaust fluid	4.6 gal (21 L)
Windshield and rear window washer system - including headlamp washer	1 gal (4.5 L)

Specifications

Materials

Name	Specification
Engine Oil - 5W-30	WSS-M2C913-C
Transmission Oil - 75W FE 7U7J-M2C200-BA/CA	WSS-M2C200-D2
Automatic Transmission Oil C-ML5 7U7J-M2C938-AB	WSS-M2C938-A
Antifreeze Super Plus Premium 4U7J-19544-xxxx	WSS-M97B44-D
Antifreeze Super Plus Premium Ready Mix 2U2J-19544-xxx	WSS-M97B44-D2
Brake Fluid DOT 4 LV High Performance BU7J-M6C65-xxxx	WSS-M6C65-A2

Maintenance

Note: If you are unable to find an engine oil that meets the specification defined, you must use an SAE 5W-30 engine oil defined by ACEA A5/B5 for top-up only.

Use oil and fluids that meet the defined specification and viscosity grades.

If you use oil and fluids that do not meet the defined specification and viscosity grades this may lead to:

- Component damage which may not be covered by the vehicle Warranty.
- Longer engine cranking periods.

- Increased emission levels.
- Reduced engine performance.
- Reduced fuel economy.
- Degraded brake performance.

We recommend that you use Castrol or Ford engine oil.



TECHNICAL SPECIFICATIONS - AWD

Capacities

Item	Capacity
Engine cooling system	3.1 gal (14 L)
Engine lubrication system - including the oil filter	2.2 gal (10.1 L)
Engine lubrication system - excluding the oil filter	2.1 gal (9.7 L)
Engine oil top-up - raise the level on the dipstick from minimum to maximum	0.4 gal (2 L)
Fuel tank - normal capacity	17.6 gal (80 L)
Fuel tank - increased capacity	20.9 gal (95 L)
Diesel exhaust fluid	4.6 gal (21 L)
Windshield and rear window washer system - including headlamp washer	1 gal (4.5 L)

Specifications

Materials

Name	Specification
Engine Oil - 5W-30	WSS-M2C913-C
Transmission Oil - 75W FE 7U7J-M2C200-BA/CA	WSS-M2C200-D2
Gear/Transmission Fluid - 75W90	GL-5

Maintenance

Name	Specification
Rear Axle Oil SAE 90 2L5J-M2C9102-AA	SR-M2C9102-A
Automatic Transmission Oil C-ML5 7U7J-M2C938-AB	WSS-M2C938-A
Antifreeze Super Plus Premium 4U7J-19544-xxxx	WSS-M97B44-D
Antifreeze Super Plus Premium Ready Mix 2U2J-19544-xxxx	WSS-M97B44-D2
Brake Fluid DOT 4 LV High Performance BU7J-M6C65-xxxx	WSS-M6C65-A2

Note: *If you unable to find an engine oil that meets the specification defined, you must use an SAE 5W-30 engine oil defined by ACEA A5/B5 for top-up only.*

Use oil and fluids that meet the defined specification and viscosity grades.

If you use oil and fluids that do not meet the defined specification and viscosity grades this may lead to:

- Component damage which may not be covered by the vehicle Warranty.
- Longer engine cranking periods.
- Increased emission levels.
- Reduced engine performance.
- Reduced fuel economy.
- Degraded brake performance.





We recommend that you use Castrol or Ford engine oil.



Vehicle Care

CLEANING THE EXTERIOR



WARNINGS

-  If you use a car wash with a waxing cycle, make sure that you remove the wax from the windshield.
-  Prior to using a car wash facility check the suitability of it for your vehicle.
-  Some car wash installations use water at high pressure. This could damage certain parts of your vehicle.
-  Remove the aerial before using an automatic car wash.
-  Switch the heater blower off to prevent contamination of the fresh air filter.

We recommend that you wash your vehicle with a sponge and lukewarm water containing a car shampoo.

Cleaning the Headlamps

WARNINGS

-  Do not scrape the headlamp lenses or use abrasives, alcoholic solvents or chemical solvents to clean them.
-  Do not wipe the headlamps when they are dry.

Cleaning the Rear Window



WARNING

-  Do not scrape the inside of the rear window or use abrasives or chemical solvents to clean it.

Use a clean, lint free cloth or a damp chamois leather to clean the inside of the rear window.



Cleaning the Chrome Trim

WARNINGS

-  Do not use abrasives or chemical solvents. Use soapy water.
-  Do not apply cleaning product to hot surfaces and do not leave cleaning product on chrome surfaces for a period of time exceeding that which is recommended.
-  Industrial-strength (heavy-duty) cleaners, or cleaning chemicals, may cause damage over a period of time.

Body Paintwork Preservation

WARNINGS

-  Do not polish your vehicle in strong sunshine.
-  Do not allow polish to touch plastic surfaces. It could be difficult to remove.
-  Do not apply polish to the windshield or rear window. This could cause the wipers to become noisy and they may not clear the window properly.

We recommend that you wax the paintwork once or twice a year.

CLEANING THE INTERIOR

Note: Do not allow air fresheners and hand sanitizers to spill on interior surfaces. If a spill occurs, wipe off immediately. Damage may not be covered by your warranty.

Safety Belts

WARNINGS

-  Do not use abrasives, or chemical solvents to clean them.

Vehicle Care

WARNINGS



Do not allow moisture to penetrate the safety belt retractor mechanism.

Clean them with interior cleaner or water applied with a soft sponge. Let them dry naturally, away from artificial heat.

Instrument Cluster Screens, LCD Screens and Radio Screens

WARNING



Do not use abrasives, alcoholic solvents or chemical solvents to clean them.

Rear Windows

WARNING



Do not use any abrasive materials to clean the interior of the rear windows.

Note: Do not install stickers or labels to the interior of the rear windows.

REPAIRING MINOR PAINT DAMAGE

You should repair paintwork damage caused by stones from the road or minor scratches as soon as possible. A choice of products are available from an authorized dealer.

Remove particles such as bird droppings, tree sap, insect deposits, tar spots, road salt and industrial fallout before repairing paint chips.

Always read and follow the manufacturer's instructions before using the products.

CLEANING THE ALLOY WHEELS

Note: Do not apply a cleaning chemical to warm or hot wheel rims and covers.

Note: Industrial-strength (heavy-duty) cleaners, or cleaning chemicals, in combination with brush agitation to remove brake dust and dirt, could wear away the clear coat finish over a period of time.

Note: Do not use hydrofluoric acid-based or high caustic-based wheel cleaners, steel wool, fuels or strong household detergent.

Note: If you intend parking your vehicle for an extended period after cleaning the wheels with a wheel cleaner, drive your vehicle for a few minutes before doing so. This will reduce the risk of increased corrosion of the brake discs, brake pads and linings.

Note: Some automatic car washes may cause damage to the finish on your wheel rims and covers.

Alloy wheels and wheel covers are coated with a clear coat paint finish. To maintain their condition we recommend that you:

- Clean them weekly with the recommended wheel and tire cleaner.
- Use a sponge to remove heavy deposits of dirt and brake dust accumulation.
- Rinse them thoroughly with a pressurized stream of water when you have completed the cleaning process.

We recommend that you use Ford service wheel cleaner. Make sure that you read and follow the manufacturer's instructions.

Using other non-recommended cleaning products can result in severe and permanent cosmetic damage.

Wheels and Tires

GENERAL INFORMATION

A decal with tire pressure data is located in the driver's door opening.

Check and set the tire pressure at the ambient temperature in which you are intending to drive your vehicle and when the tires are cold.

Note: Check your tire pressures regularly to optimize fuel economy.

Note: Use only approved wheel and tire sizes. Using other sizes could damage your vehicle and will make the National Type Approval invalid.

Note: If you change the diameter of the tires from that fitted at the factory, the speedometer may not display the correct speed. Take your vehicle to an authorized dealer to have the engine management system reprogrammed.

Note: If you intend to change the size of the wheels from that fitted at the factory, check the suitability with an authorized dealer.

TEMPORARY MOBILITY KIT

WARNING



Motorhome owners must refer to separate instructions issued with the temporary mobility kit.

Your vehicle may not have a spare wheel and tire. In these cases it will be supplied with a temporary mobility kit which will only repair one damaged tire.

The compressor is located under the passenger seat. The sealant bottle is located in the right-hand side stepwell.

Note: The compressor is located in the load space area on vehicles with rear climate control.

General Information

WARNINGS



Depending on the type and extent of tire damage, some tires can only be partially sealed or not sealed at all.

Loss of tire pressure can affect vehicle handling, leading to loss of vehicle control.



Do not use the temporary mobility kit on a previously damaged tire. For example, when a tire has been driven under inflated.



Do not use the temporary mobility kit to run flat tires.



Do not use the temporary mobility kit to repair the sidewall of a damaged tire.

The temporary mobility kit seals most tire punctures with a diameter of up to ¼ in (6 mm) to temporarily restore mobility.





You must observe the following rules when using the temporary mobility kit:

- Drive with caution and avoid making sudden steering or driving manoeuvres especially if your vehicle is heavily loaded or towing a trailer.
- Only continue your journey to the next vehicle or tire dealer or drive a maximum distance of 125 miles (200 kilometers).
- Do not exceed a maximum speed of 50 mph (80 km/h).
- Keep the temporary mobility kit out of the reach of children.
- Only use the temporary mobility kit when the ambient temperature is between -30° and 70° C (-22° and 158° F).

Wheels and Tires

Using the Temporary Mobility Kit

WARNINGS







-  Park your vehicle so that you do not obstruct the flow of traffic or place yourself in any danger and set up a warning triangle.
-  Compressed air can act as an explosive or propellant.
-  Never leave the temporary mobility kit unattended while in use.
-  Do not keep the compressor operating for longer than 10 minutes.
-  You must only use the temporary mobility kit for the vehicle with which it was supplied.

Before you use the temporary mobility kit:

- Apply the parking brake.
- Do not attempt to remove foreign material that is penetrating the tire, for example, nails or screws.
- Leave the engine running while the temporary mobility kit is in use. If your vehicle is in an enclosed or poorly ventilated area use the temporary mobility kit with the engine switched off.
- You must replace the sealant bottle with a new one before the expiry date which is printed on the top of sealant bottle.
- Inform all vehicle users that a tire has been repaired using the temporary mobility kit. Make them aware of the special driving conditions that apply.

Inflating the Tire

WARNINGS

-  Check the sidewall of the tire prior to using the temporary mobility kit. If there are any cracks, bumps or similar damage do not attempt to inflate the tire.
-  Do not stand directly beside the tire while the compressor is operating.
-  Watch the sidewall of the tire. If any cracks, bumps or similar damage appears, switch off the compressor immediately and deflate the tire using the pressure relief valve B.
-  The sealant contains natural rubber latex. Avoid contact with skin or clothing. If this happens, rinse the affected areas immediately with plenty of water and contact a physician.
-  If the tire inflation pressure does not reach 44 psi (3 bar) within 10 minutes, the tire may have suffered excessive damage. Do not continue driving with this tire.
-  Screwing the sealant bottle onto the bottle holder will pierce the seal of the sealant bottle. Do not unscrew the sealant bottle from the bottle holder prior to completing a temporary repair as the sealant will escape.
-  If you experience heavy vibrations, unsteady steering behavior or noises while driving, reduce your speed and drive with caution to a place where it is safe for you to stop your vehicle. Recheck the tire and its pressure. If the tire pressure is less than 44 psi (3 bar) or if there are any cracks, bumps or similar damage visible, do not continue driving with this tire.

Wheels and Tires

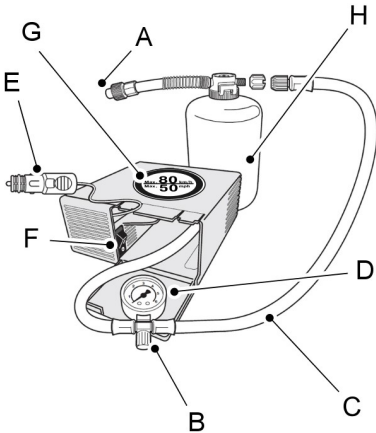

E146784

- A Protective cap
- B Pressure relief valve
- C Hose
- D Pressure gauge
- E Power plug with cable
- F Compressor switch
- G Label
- H Sealant bottle

1. Open the lid of the temporary mobility kit.
2. Peel off the label G showing the maximum permissible speed of 50 mph (80 km/h) from the casing and attach it to the instrument panel in the driver's field of view. Make sure the label does not obscure anything important.
3. Take the hose C and the power plug with cable E out of the temporary mobility kit.
4. Screw the hose C onto the sealant bottle.
5. Remove the valve cap from the damaged tire.
6. Remove the protective cap A from the sealant bottle hose and screw the hose firmly onto the valve of the damaged tire.
7. Make sure that the compressor switch F is in position 0.
8. Insert the power plug E into the auxiliary power point. See **Auxiliary Power Points** (page 89).
9. Start the engine.
10. Move the compressor switch F to position 1.
11. After a minimum of two minutes move the compressor switch F to position 0 and unscrew the hose C from the sealant bottle. Unscrew the sealant bottle hose from the tire valve.
12. Screw the hose C onto the tire valve and move the compressor switch F to position 1.
13. Inflate the tire for no longer than 10 minutes or to an inflation pressure of a minimum of 44 psi (3 bar) and a maximum of 73 psi (5 bar). Move the compressor switch F to position 0 and check the current tire pressure with pressure gauge D. Unscrew the hose C from the tire valve.
14. Remove the power plug E from the auxiliary power point.
15. Make sure the temporary mobility kit, the bottle lid and the orange cap are stored safely, but still easily accessible in your vehicle. The temporary mobility kit will be required again when you check the tire pressure.
16. Immediately drive approximately six miles (10 kilometers) so that the sealant can seal the damaged area.

Wheels and Tires

Note: When pumping in the sealant through the tire valve, the pressure may rise up to 87 psi (6 bar) but will drop again after about 30 seconds.

Checking the Tire Pressure

WARNING



Before driving make sure the tire is adjusted to the recommended inflation pressure. See **Technical Specifications** (page 190). Monitor the tire pressure until the sealed tire is replaced.

1. Stop your vehicle after driving approximately six miles (10 kilometers). Check, and where necessary, adjust the pressure of the damaged tire.
2. Attach the temporary mobility kit and check the tire pressure from the pressure gauge D.
3. If the pressure of the damaged tire is 44 psi (3 bar) or more, adjust it to the specified pressure. See **Technical Specifications** (page 190).
4. Follow the inflation procedure once again to inflate the tire.
5. Check the tire pressure again from the pressure gauge D. If the tire pressure is too high, deflate the tire to the specified pressure using the pressure relief valve B.
6. If the tire pressure is below 44 psi (3 bar), repeat steps 13 to 16 and steps 1 to 5 (Checking the Tire Pressure).
7. Once you have inflated the tire to its correct tire pressure, move the compressor switch F to position O, remove the power plug E from the auxiliary power point, unscrew the sealant bottle hose, fasten the valve cap and replace the protective cap A.

8. Drive to the nearest tire specialist to get the damaged tire replaced. Before the tire is removed from the wheel, inform the tire specialist that the tire contains sealant. Renew the sealant bottle as soon as possible after it has been used once.

Note: The temporary mobility kit only provides an emergency repair. Regulations concerning tire repair after using the temporary mobility kit may differ from country to country. You should consult a tire specialist for advice.

Empty sealant bottles can be disposed of together with normal household waste. Return remaining sealant to an authorized dealer or dispose of it in compliance with local waste disposal regulations.

TIRE CARE



E70415

To make sure the front and rear tires of your vehicle wear evenly and last longer, we recommend that you swap the tires from front to rear and vice versa at regular intervals of between 3000 and 6000 miles (5000 and 10000 kilometers).

WARNING



Do not scrub the sidewalls of the tires when you are parking.

Wheels and Tires

If you have to mount a curb, do so slowly and approach it with the wheels at right-angles to the curb.

Examine the tires regularly for cuts, foreign objects and uneven wear of the tread. Uneven wear could mean that the wheel alignment is outside specification.

Check the tire pressures (including the spare) when cold, every two weeks.

USING WINTER TIRES

If winter tires are used you must make sure that you use the correct tire pressures. See **Technical Specifications** (page 190).

USING SNOW CHAINS

WARNINGS



Do not exceed 31 mph (50 km/h).



Do not use snow chains on snow-free roads.



Only fit snow chains to specified tires. See **Technical Specifications** (page 190).



If your vehicle has wheel trims, remove them before fitting snow chains.

Only use snow chains of 10 millimeters or smaller.

Only use snow chains on the driven wheels.

Note: *The anti-lock brake system will continue to operate normally.*

Vehicles with Stability Control

When stability control is on, your vehicle may exhibit some unusual driving characteristics. To reduce this, switch traction control off. See **Using Traction Control** (page 112).

TIRE PRESSURE MONITORING SYSTEM

WARNING



The tire pressure monitoring system is not a substitute for manually checking tire pressures. You should periodically check tire pressures using a pressure gauge. Failure to correctly maintain tire pressures could increase the risk of tire failure, loss of control, vehicle rollover and personal injury.



You must check the tire pressures (including the spare tire where applicable) every two weeks when the tires are cold.

You must inflate the tires to the correct pressure.

See **Wheels and Tires** (page 176). The tire pressures are also on the tire inflation pressure label (located on the edge of driver door or the B-Pillar).

As a driver assistance feature, your vehicle has a tire pressure monitoring system. A warning lamp will illuminate when one or more of the tires are significantly under-inflated. If the low tire pressure warning lamp illuminates, you should stop your vehicle as soon as it is safe to do so, check the tires and inflate them to the correct pressure.

Driving on under-inflated tires can:

- Cause them to overheat.
- Lead to tire failure.
- Reduce fuel efficiency.
- Reduce tire life.
- Affect vehicle handling or stopping ability.

Wheels and Tires

The system is not a substitute for correct tire maintenance.

You must maintain the correct tire pressures, even if low tire pressure has not illuminated the warning lamp.

The tire pressure monitoring system has a system malfunction indicator to warn you when the system is not operating correctly. The malfunction indicator and low tire pressure warning lamp have a combined function. When the system detects a malfunction, the warning lamp will flash for approximately one minute and then remain illuminated. This sequence will occur every time you switch the ignition on while the malfunction remains. The system has detected a fault that requires service.

When the malfunction indicator is illuminated, the system may not be able to detect or signal low tire pressures. A malfunction may occur for a variety of reasons, including the installation of a replacement tire or wheel that prevents the system from functioning correctly. Always check the tire pressure monitoring system malfunction warning after replacing one or more tires or wheels on your vehicle. Make sure the replacement tires or wheels allow the system to continue to function correctly. See **When the Temporary Spare Tire is Installed** in this section.

Changing Tires With a Tire Pressure Monitoring System



E142549

You should always have tires serviced by an authorized dealer.

Note: Each road wheel and tire is fitted with a tire pressure sensor located inside the wheel and tire assembly cavity. The pressure sensor attaches to the valve stem. The tire covers the pressure sensor and it is not visible unless the tire is removed. Take care when changing the tire to avoid damaging the sensor.

Understanding the Tire Pressure Monitoring System

The system measures the pressure in the four road tires and sends the tire pressure readings to your vehicle.

The system detects this lower pressure as being significantly below the correct inflation pressure and the warning lamp illuminates. You must inflate the tires to the correct pressure.

When the Temporary Spare Tire is Installed

If you need to replace a road wheel and tire with the temporary spare wheel, the system will continue to identify a defect. This is to remind you to repair the damaged road wheel and tire and refit the repaired road wheel and tire assembly to your

Wheels and Tires

vehicle. To restore the correct operation of the system, you must have the repaired road wheel and tire assembly refitted to your vehicle. For additional information, see **Changing Tires with a Tire Pressure Monitoring System** in this section.

When You Believe the System is Not Operating Correctly

The main function of the system is to warn you when the tire pressures are low. It can also warn you in the event the system is no longer capable of operating correctly. See the following chart for information concerning the system:

Warning lamp	Description	Action
Solid warning lamp	Tire(s) under-inflated	<ol style="list-style-type: none"> 1. Make sure tires are at the correct pressure. See Wheels and Tires (page 176). The tire pressures are also on the tire inflation pressure label (located on the edge of driver door or the B-Pillar). 2. After inflating the tires to the correct pressure you must carry out the tire pressure monitoring system reset procedure. See Tire Pressure Monitoring System Reset Procedure in this chapter.
	Spare tire in use	Repair the damaged road wheel and tire and refit the repaired road wheel and tire assembly to your vehicle to restore the correct operation of the system.
Flashing warning lamp	Tire pressure monitoring system malfunction	If the tires are correctly inflated and the spare tire is not in use but the light remains on, the system has detected a fault that requires service.
	Spare tire in use	Repair the damaged road wheel and tire and refit the repaired road wheel and tire assembly to your vehicle to restore the correct operation of the system.
Flashing warning lamp	Tire pressure monitoring system malfunction	If the tires are correctly inflated and the spare tire is not in use but the light remains on, the system has detected a fault that requires service.

Wheels and Tires

Tire Pressure Monitoring System Reset Procedure

Overview

You must carry out the system reset procedure after each tire replacement or adjustment of the tire pressures.

To maintain your vehicle load carrying capability, your vehicle requires different tire pressures in the front tires compared to the rear tires.

The system illuminates the warning lamp at different pressures for the front and rear tires.

The tires need to be periodically rotated to provide consistent performance and maximum tire life, the system needs to know when the tires have been rotated to determine which set of tires are on the front and rear axles. With this information, the system can detect and correctly warn of low tire pressures.

Carrying Out the System Reset Procedure

Switch the ignition on. Using the information display control select:

Message	Description and Action
Settings	
Driver assist	
Tyre monitor	Press and hold the OK button until confirmation appears. Alternatively, if your vehicle has a tire pressure monitoring system reset button, press and hold the button until confirmation appears.

How Temperature Affects the Tire Pressures

Under normal driving conditions tire pressures may increase by up to 4 psi (0.3 bar) from a cold start situation.

If the vehicle is stationary overnight and the temperature significantly lower than the daytime temperature, tire pressures may decrease by up to 3 psi (0.2 bar) when there is a drop in the ambient temperature of 63°F (17°C) or more. The system detects this pressure decrease as being significantly below the correct inflation pressure and the warning lamp illuminates.

When Inflating the Tires

When inflating the tires the system may not respond immediately to the air added to the tires.

If the Warning Lamp is On:

1. Check each tire to verify that none are flat.
2. If one or more tires are flat, repair as necessary.
3. Check the tire pressures and inflate all the tires to the correct pressure.
4. Carry out the tire pressure monitoring system reset procedure.

Wheels and Tires

CHANGING A ROAD WHEEL

WARNING



Do not fit more than one spare wheel on your vehicle at any one time.

Locking Lug Nuts

You can obtain replacement locking lug nuts or a locking lug nut key using the reference number certificate.

Vehicles with a Spare Wheel

The spare wheel is located underneath the rear of your vehicle.

Note: *Vehicles with a temporary mobility kit do not have a spare wheel. See **Temporary Mobility Kit** (page 176).*

If the spare wheel is the same type and size as your vehicle road wheel, you can fit the spare wheel and continue to drive in the normal manner.

If the spare wheel is not the same type and size as your vehicle road wheel, it will have a label showing the maximum speed limit.



E145138

1. Open the rear doors. Remove the grommet and insert the flat end of the wheel brace and the short arm of the jack handle into the socket. Turn counterclockwise until the spare wheel rests on the ground and the cable is loose.



E146811

2. Raise the cable end cover.



E146812

Wheels and Tires

3. Rotate the cable through 90 degrees. Slide the cable through the slot to release the spare wheel bracket from the winch.

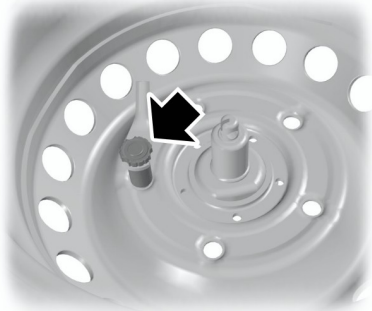







E146813

4. Remove the retaining nut to release the spare wheel bracket.

Vehicle Jack

WARNINGS

-  Only use the vehicle jack supplied with your vehicle when changing a wheel in an emergency.
-  The vehicle jack must not be damaged or deformed and the thread lubricated and free from foreign material.
-  Never place anything between the vehicle jack and the ground.
-  Never place anything between the vehicle jack and your vehicle.
-  Make sure that the vehicle jack is vertical to the jacking point and the base is flat on the ground.
-  Do not work on your vehicle when the jack is the only support. If the vehicle slips off the jack, you or someone else could be seriously injured.

Note: Vehicles with a Temporary Mobility Kit do not have a vehicle jack or a wheel brace. See **Temporary Mobility Kit** (page 176).

Front Wheel Drive Vehicles and Rear Wheel Drive Vehicles up to T370

The vehicle jack and wheel brace are located in a storage compartment in the front right-hand side stepwell.

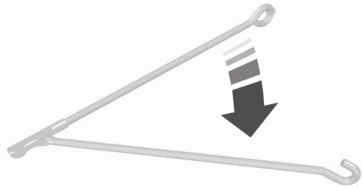

E146837

1. Unfold the jack handle.

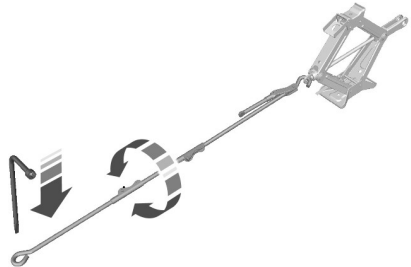

E70958

2. Insert the hook of the jack handle into the ring on the vehicle jack. Insert the wheel brace into the end of the jack handle and rotate clockwise to raise your vehicle. Rotate counterclockwise to lower your vehicle.

Wheels and Tires

Rear Wheel Drive Vehicles T410 and Over

The vehicle jack is located under the passenger seat. The jack handle and wheel brace are located in a storage compartment in the front right-hand side stepwell.

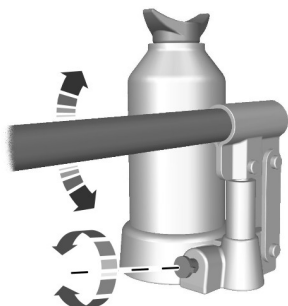

E70959

1. Assemble the jack handle.
2. Insert the jack handle onto the release valve and turn clockwise until you feel a strong resistance.
3. Insert the jack handle into the pump and use a pumping action to raise your vehicle. Insert the jack handle onto the release valve and rotate counterclockwise to lower your vehicle.

Front Jacking Points

WARNING



You must use the specified jacking points.

Note: If your vehicle has rear air conditioning make sure the vehicle jack does not come in contact with the air conditioning lines.

Front Wheel Drive Vehicles and Rear Wheel Drive Vehicles up to T370.

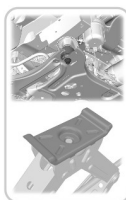
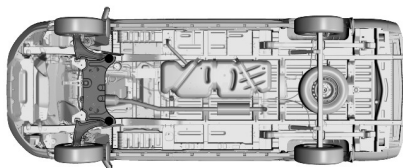
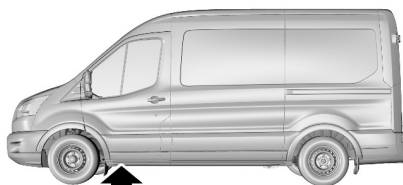

E170180

Position the head of the vehicle jack under the front sub-frame rear mounting bolts.

Rear Wheel Drive Vehicles T410 and Over.

Wheels and Tires

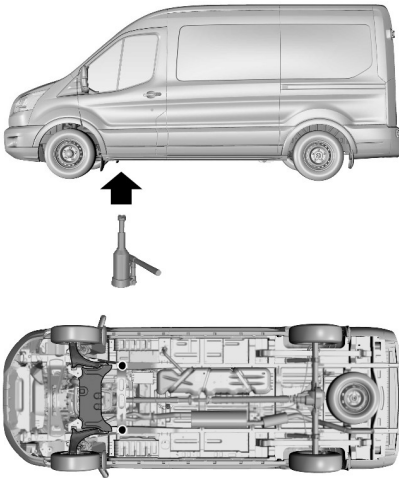

E171405

Position the head of the vehicle jack under the protrusions at the rear of front sub-frame.

Rear Jacking Points

WARNING



You must use the specified jacking points.

Front Wheel Drive Vehicles and Rear Wheel Drive Vehicles up to T370.

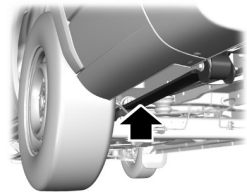
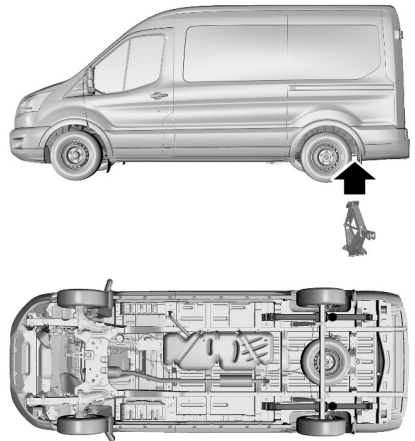

E170181

Position the head of the vehicle jack under the rear leaf spring directly behind the rear wheel.

Rear Wheel Drive Vehicles T410 and Over.

Wheels and Tires

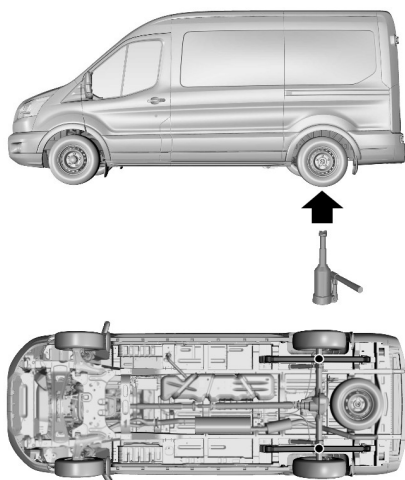



E171406

Position the head of the vehicle jack under the rear axle.

Removing a Road Wheel

WARNINGS

 Park your vehicle so that you do not obstruct the flow of traffic or place yourself in any danger and set up a warning triangle.

 Switch the ignition off and apply the parking brake.

 If your vehicle has a manual transmission, move the transmission selector lever to first or reverse gear. If your vehicle has an automatic transmission, move the transmission selector lever to position **P**.

 Make sure all passengers are out of your vehicle.

 Make sure that your vehicle is on firm and level ground with the front wheels pointing straight ahead.

WARNINGS

 Chock the diagonally opposite wheel to the punctured tire with an appropriate block or wheel chock. A wheel chock may be located in the B-pillar or in a storage compartment in the front right-hand side stepwell.

 Make sure that the arrows on directional tires point in the direction of rotation when your vehicle is moving forward. If you have to fit a spare wheel and tire with the arrows pointing in the opposite direction have the tire refitted as soon as possible.

1. Insert the flat end of the wheel brace between the rim and the wheel trim and carefully remove the wheel trim.
2. Use the locking lug nut key to loosen the locking lug nut.
3. Loosen the remaining lug nuts, but do not remove them.
4. Raise your vehicle until the wheel and tire is clear of the ground.
5. Remove the lug nuts and the road wheel.

Note: *Do not lay alloy road wheels face down on the ground.*

Installing a Road Wheel

WARNINGS

 Use only approved wheel and tire sizes. Using other wheel and tire sizes could damage your vehicle and will make the National Type Approval invalid. See **Technical Specifications** (page 190).

 Make sure there is no lubrication (grease or oil) on the threads or the surface between the wheel lugs and nuts. This can cause the lug nuts to loosen while driving.

Wheels and Tires

WARNINGS



Make sure the wheel and hub contact surfaces are free from foreign material.

1. Install the wheel.

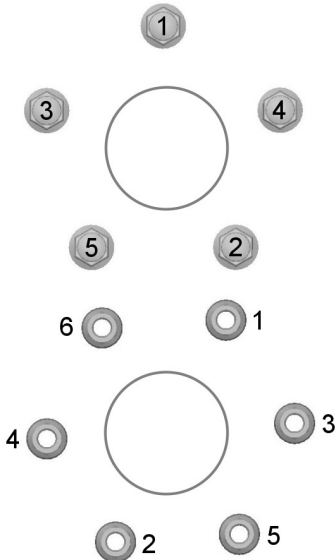

E70961

2. Install all of the lug nuts and partially tighten them in the sequence shown.
3. Lower your vehicle and remove the vehicle jack.
4. Fully tighten all of the lug nuts in the sequence shown. See **Technical Specifications** (page 190).
5. Install the wheel trim.

Note: Make sure that the cones on the lug nuts are against the wheel.

Note: Alloy wheel lug nuts are suitable for use on a steel spare wheel.

Note: If the spare wheel is not the same type and size as your vehicle road wheel replace it as soon as possible.

Note: Check the lug nuts for correct tightness and check the tire pressure as soon as possible. See **Technical Specifications** (page 190).

Stowing the Wheel and Vehicle Jack

Note: Do not raise the spare wheel bracket without a wheel attached. Damage can occur to the winch mechanism if the spare wheel bracket is lowered without a wheel attached.

1. Attach the spare wheel bracket to the wheel using the retaining nut.
2. Slide the cable through the slot and attach the spare wheel bracket to the winch.
3. Rotate the cable through 90 degrees and lower the cable end cover.



E145138

4. Insert the flat end of the wheel brace or the short arm of the jack handle into the socket. Turn it clockwise until you feel a strong resistance. Make sure the wheel is secure.

Wheels and Tires

5. Stow the vehicle jack, jack handle and wheel brace in their correct locations

and secure them with the straps.

TECHNICAL SPECIFICATIONS

Lug Nut Torque

Wheel type	lb.ft (Nm)
All	148 lb.ft (200 Nm)

Tire Pressures (Cold Tires)

Van, Kombi-Van and Kombi (front wheel drive)

Vehicle type	Tire size	Front	Rear
		psi (bar)	psi (bar)
280, vehicles with steel wheels	215/65 R15C	51 psi (3.5 bar)	48 psi (3.3 bar)
280, vehicles with alloy wheels	215/65 R16C	54 psi (3.7 bar)	52 psi (3.6 bar)
290, vehicles with steel wheels	215/65 R15C	51 psi (3.5 bar)	48 psi (3.3 bar)
290, vehicles with alloy wheels	215/65 R16C	54 psi (3.7 bar)	52 psi (3.6 bar)
310L, vehicles with steel wheels	215/65 R15C	54 psi (3.75 bar)	54 psi (3.7 bar)
310L, vehicles with alloy wheels	215/65 R16C	58 psi (4 bar)	58 psi (4 bar)
310L Econetic	215/65 R16C	58 psi (4 bar)	58 psi (4 bar)
310M, vehicles with steel wheels	215/65 R15C	51 psi (3.5 bar)	54 psi (3.7 bar)
310M, vehicles with alloy wheels	215/65 R16C	55 psi (3.8 bar)	58 psi (4 bar)
310M Econetic	215/65 R16C	55 psi (3.8 bar)	58 psi (4 bar)
330	235/65 R16C	48 psi (3.3 bar)	58 psi (4 bar)
350L	235/65 R16C	48 psi (3.3 bar)	65 psi (4.5 bar)

Wheels and Tires

Vehicle type	Tire size	Front	Rear
		psi (bar)	psi (bar)
350M	235/65 R16C	48 psi (3.3 bar)	61 psi (4.2 bar)
350L, vehicles with maximum front axle weight 1850 kg	235/65 R16C	51 psi (3.5 bar)	61 psi (4.2 bar)
350M, vehicles with maximum front axle weight 1850 kg	235/65 R16C	48 psi (3.3 bar)	61 psi (4.2 bar)
410	235/65 R16C	49 psi (3.4 bar)	71 psi (4.9 bar)

Van, Kombi-Van and Kombi (rear wheel drive and all-wheel drive)

Vehicle type	Tire size	Front	Rear
		psi (bar)	psi (bar)
310	235/65 R16C	48 psi (3.3 bar)	46 psi (3.2 bar)
350L and 370L, vehicles with maximum front axle weight 1750 kg	235/65 R16C	48 psi (3.3 bar)	65 psi (4.5 bar)
350L and 370L, vehicles with maximum front axle weight 1850 kg	235/65 R16C	51 psi (3.5 bar)	65 psi (4.5 bar)
350M, vehicles with maximum front axle weight 1750 kg	235/65 R16C	48 psi (3.3 bar)	61 psi (4.2 bar)
350M, vehicles with maximum front axle weight 1850 kg	235/65 R16C	51 psi (3.5 bar)	61 psi (4.2 bar)

Wheels and Tires

Chassis Cab (front wheel drive)

Vehicle type	Tire size	Front	Rear
		psi (bar)	psi (bar)
310	215/65 R16C	55 psi (3.8 bar)	58 psi (4 bar)
330	235/65 R16C	48 psi (3.3 bar)	58 psi (4 bar)
350L	235/65 R16C	48 psi (3.3 bar)	65 psi (4.5 bar)
350M	235/65 R16C	48 psi (3.3 bar)	61 psi (4.2 bar)

Chassis Cab (rear wheel drive and all-wheel drive)

Vehicle type	Tire size	Front	Rear
		psi (bar)	psi (bar)
310	235/65 R16C	42 psi (2.9 bar)	46 psi (3.2 bar)
330	235/65 R16C	44 psi (3 bar)	58 psi (4 bar)
350E and 350L, vehicles with maximum front axle weight 1750 kg	235/65 R16C	48 psi (3.3 bar)	65 psi (4.5 bar)
350E and 350L, vehicles with maximum front axle weight 1850 kg	235/65 R16C	51 psi (3.5 bar)	65 psi (4.5 bar)
350M single and double cab, vehicles with maximum front axle weight 1750 kg	235/65 R16C	48 psi (3.3 bar)	61 psi (4.2 bar)
350M single and double cab, vehicles with maximum front axle weight 1850 kg	235/65 R16C	51 psi (3.5 bar)	61 psi (4.2 bar)

Wheels and Tires

Bus

Vehicle type	Tire size	Front	Rear
		psi (bar)	psi (bar)
350, vehicles with maximum front axle weight 1750 kg	235/65 R16C	48 psi (3.3 bar)	59 psi (4.1 bar)
350, vehicles with maximum front axle weight 1850 kg	235/65 R16C	51 psi (3.5 bar)	59 psi (4.1 bar)
370, vehicles with maximum front axle weight 1750 kg	235/65 R16C	48 psi (3.3 bar)	65 psi (4.5 bar)
370, vehicles with maximum front axle weight 1850 kg	235/65 R16C	51 psi (3.5 bar)	65 psi (4.5 bar)
410	235/65 R16C	49 psi (3.4 bar)	71 psi (4.9 bar)
460	195/75 R16C	67 psi (4.6 bar)	57 psi (3.9 bar)

Van, Kombi and Chassis Cab (dual rear wheel)

Vehicle type	Tire size	Front	Rear
		psi (bar)	psi (bar)
350, vehicles with maximum front axle weight 1750 kg	195/75 R16C	62 psi (4.3 bar)	44 psi (3 bar)
350, vehicles with maximum front axle weight 1850 kg	195/75 R16C	67 psi (4.6 bar)	44 psi (3 bar)
410	195/75 R16C	67 psi (4.6 bar)	46 psi (3.2 bar)
430	195/75 R16C	67 psi (4.6 bar)	55 psi (3.8 bar)
470	195/75 R16C	67 psi (4.6 bar)	62 psi (4.3 bar)

Wheels and Tires

Snow Chain Wheel

Vehicle type	Tire size	psi (bar)
All vehicles with front wheel drive, maximum front axle weight 1750 kg.	185/75 R16C	62 psi (4.3 bar)
All vehicles with front wheel drive, maximum front axle weight 1850 kg.	195/75 R16C	67 psi (4.6 bar)
All vehicles with rear wheel drive.*	235/65 R16C	51 psi (3.5 bar)

*Only fit snow chains to the outer tires on vehicles with dual rear wheels.

Capacities and Specifications

VEHICLE DIMENSIONS

Van/Kombi/Bus

Medium Wheelbase

Description	Variant	
	in (mm)	
Overall length	217.8 in (5,531 mm)	
Overall width including exterior mirrors	97.4 in (2,474 mm)	
Overall height (measured at curb weight)	Minimum	Maximum
	98.0 in (2,490 mm)	109.8 in (2,789 mm)
Wheelbase	129.9 in (3,300 mm)	
Front track	68.2 in (1,732 mm)	
Rear track	68.6 in (1,743 mm)	

Long Wheelbase

Description	Variant	
	in (mm)	
Overall length	235.5 in (5,981 mm)	
Overall width including exterior mirrors	97.4 in (2,474 mm)	
Overall height (measured at curb weight)	Minimum	Maximum
	97.7 in (2,481 mm)	109.9 in (2,792 mm)
Wheelbase	147.6 in (3,750 mm)	
Front track	68.2 in (1,732 mm)	
Rear track	68.6 in (1,743 mm)	

Capacities and Specifications

Long Wheelbase Extended Frame

Description	Variant	
	in (mm)	
Overall length	263.9 in (6,704 mm)	
Overall width including exterior mirrors	97.4 in (2,474 mm)	
Overall height (measured at curb weight)	Minimum	Maximum
	108.3 in (2,750 mm)	109.5 in (2,782 mm)
Wheelbase	147.6 in (3,750 mm)	
Front track single wheel and dual wheel	68.2 in (1,732 mm)	68.5 in (1,740 mm)
Rear track single wheel and dual wheel	68.6 in (1,743 mm)	65.7 in (1,670 mm)

Chassis Cab

Short Wheelbase

Description	Variant	
	in (mm)	
Overall length	204.9 in (5,205 mm)	
Overall width including exterior mirrors	97.4 in (2,474 mm)	
Overall height (measured at curb weight)	Minimum	Maximum
	86.3 in (2,192 mm)	87.4 in (2,219 mm)
Wheelbase	123.5 in (3,137 mm)	
Front track	68.2 in (1,732 mm)	
Rear track	68.6 in (1,743 mm)	

Capacities and Specifications

Medium Wheelbase

Description	Variant	
	in (mm)	
Overall length	219.4 in (5,572 mm)	
Overall width including standard or wide exterior mirrors	Minimum	Maximum
	97.4 in (2,474 mm)	108.1 in (2,746 mm)
Overall height (measured at curb weight)	85.4 in (2,168 mm)	87.2 in (2,214 mm)
Wheelbase	138.0 in (3,504 mm)	
Front track single wheel and dual wheel	68.2 in (1,732 mm)	68.5 in (1,740 mm)
Rear track single wheel and dual wheel	68.6 in (1,743 mm)	65.7 in (1,670 mm)

Long Wheelbase

Description	Variant	
	in (mm)	
Overall length	259.9 in (6,602 mm)	
Overall width including standard or wide exterior mirrors	Minimum	Maximum
	97.4 in (2,474 mm)	108.1 in (2,746 mm)
Overall height (measured at curb weight)	85.9 in (2,183 mm)	86.9 in (2,207 mm)
Wheelbase	155.7 in (3,954 mm)	
Front track single wheel and dual wheel	68.2 in (1,732 mm)	68.5 in (1,740 mm)
Rear track single wheel and dual wheel	68.6 in (1,743 mm)	65.7 in (1,670 mm)

Long Wheelbase Extended Frame Single Chassis Cab

Description	Variant	
	in (mm)	
Overall length	259.0 in (6,579 mm)	
Overall width including standard or wide exterior mirrors	Minimum	Maximum
	97.4 in (2,474 mm)	108.1 in (2,746 mm)

Capacities and Specifications

Description	Variant	
	in (mm)	
Overall height (measured at curb weight)	85.9 in (2,183 mm)	86.9 in (2,207 mm)
Wheelbase	155.7 in (3,954 mm)	
Front track single wheel and dual wheel	68.2 in (1,732 mm)	68.5 in (1,740 mm)
Rear track single wheel and dual wheel	68.6 in (1,743 mm)	65.7 in (1,670 mm)

Long Wheelbase Extended Frame Double Chassis Cab

Description	Variant	
	in (mm)	
Overall length	252.1 in (6,404 mm)	
Overall width including standard or wide exterior mirrors	Minimum	Maximum
	97.4 in (2,474 mm)	108.1 in (2,746 mm)
Overall height (measured at curb weight)	86.5 in (2,198 mm)	86.6 in (2,200 mm)
Wheelbase	155.7 in (3,954 mm)	
Front track single wheel and dual wheel	68.2 in (1,732 mm)	68.5 in (1,740 mm)
Rear track single wheel and dual wheel	68.6 in (1,743 mm)	65.7 in (1,670 mm)

Extra Long Wheelbase Extended Frame Single Chassis Cab

Description	Variant	
	in (mm)	
Overall length	298.3 in (7,577 mm)	
Overall width including standard or wide exterior mirrors	Minimum	Maximum
	97.4 in (2,474 mm)	108.1 in (2,746 mm)
Overall height (measured at curb weight)	86.4 in (2,195 mm)	86.5 in (2,197 mm)
Wheelbase	178.0 in (4,522 mm)	
Front track single wheel and dual wheel	68.2 in (1,732 mm)	68.5 in (1,740 mm)
Rear track single wheel and dual wheel	68.6 in (1,743 mm)	65.7 in (1,670 mm)

Capacities and Specifications

Extra Long Wheelbase Extended Frame Double Chassis Cab

Description	Variant	
	in (mm)	
Overall length	291.1 in (7,394 mm)	
Overall width including standard or wide exterior mirrors	Minimum	Maximum
	97.4 in (2,474 mm)	108.1 in (2,746 mm)
Overall height (measured at curb weight)	86.1 in (2,187 mm)	86.3 in (2,191 mm)
Wheelbase	178.0 in (4,522 mm)	
Front track single wheel and dual wheel	68.2 in (1,732 mm)	68.5 in (1,740 mm)
Rear track single wheel and dual wheel	68.6 in (1,743 mm)	65.7 in (1,670 mm)

Motorhome Chassis

Medium Wheelbase

Description	Variant	
	in (mm)	
Overall length	209.5 in (5,321 mm)	
Overall width including standard or wide exterior mirrors	97.4 in (2,474 mm)	108.1 in (2,746 mm)
	87.1 in (2,212 mm)	
Wheelbase	129.9 in (3,300 mm)	
Front track	68.2 in (1,732 mm)	
Rear track	68.6 in (1,743 mm)	

Capacities and Specifications

Long Wheelbase

Description	Variant	
	in (mm)	
Overall length	235.2 in (5,975 mm)	
Overall width including standard or wide exterior mirrors	97.4 in (2,474 mm)	108.1 in (2,746 mm)
Overall height (measured at curb weight)	86.8 in (2,205 mm)	
Wheelbase	147.6 in (3,750 mm)	
Front track	68.2 in (1,732 mm)	
Rear track	68.6 in (1,743 mm)	

Long Wheelbase Extended Frame

Description	Variant	
	in (mm)	
Overall length	235.2 in (5,975 mm)	
Overall width including standard or wide exterior mirrors	97.4 in (2,474 mm)	108.1 in (2,746 mm)
Overall height (measured at curb weight)	86.6 in (2,199 mm)	
Wheelbase	155.7 in (3,954 mm)	
Front track	68.2 in (1,732 mm)	
Rear track	68.6 in (1,743 mm)	

TOWBAR DIMENSIONS

Maximum Permissible Nose Weight All Vehicles

lb (kg)
247 lb (112 kg)

Capacities and Specifications

Van/Kombi/Bus

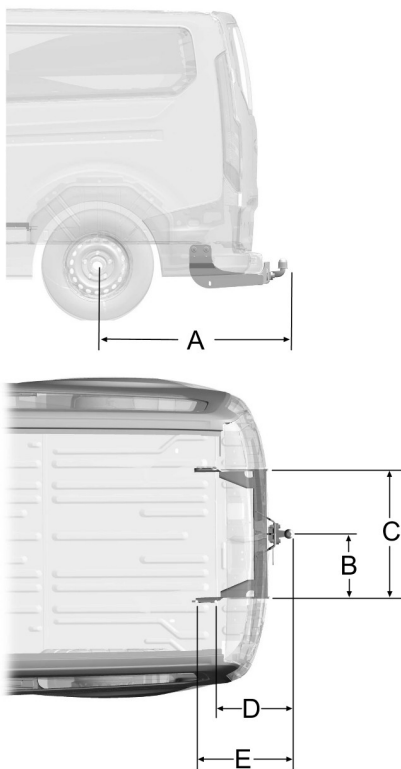

E148831

Capacities and Specifications

Measurement	Dimension description	in (mm)
A	wheel center – end of tow ball	53.8 in (1,367 mm)
B	Center of tow ball - side member	14.6 in (371.5 mm)
C	Inner side of side member	29.3 in (743 mm)
D	Center of tow ball – center 1.attachment point	24.8 in (629 mm)
E	Center of tow ball – center 2.attachment point	27.7 in (704 mm)

Single Chassis Cab

Short Medium and Long Wheelbase

Measurement	Dimension description	in (mm)
A	wheel center – end of tow ball	46.4 in (1,178 mm)
B	Center of tow ball - side member	16.5 in (418 mm)
C	Inner side of side member	32.9 in (836 mm)
D	Center of tow ball – center 1.attachment point	9.3 in (237 mm)
E	Center of tow ball – center 2.attachment point	13.5 in (343.5 mm)

Capacities and Specifications

Long and Extra Long Wheelbase Extended Frame

Measurement	Dimension description	in (mm)
A	wheel center – end of tow ball	85.2 in (2,165 mm)
B	Center of tow ball - side member	16.5 in (418 mm)
C	Inner side of side member	32.9 in (836 mm)
D	Center of tow ball – center 1.attachment point	9.3 in (237 mm)
E	Center of tow ball – center 2.attachment point	13.5 in (343.5 mm)

Double Chassis Cab

Short Medium and Long Wheelbase

Measurement	Dimension description	in (mm)
A	wheel center – end of tow ball	46.4 in (1,178 mm)
B	Center of tow ball - side member	16.5 in (418 mm)
C	Inner side of side member	32.9 in (836 mm)
D	Center of tow ball – center 1.attachment point	9.3 in (237 mm)
E	Center of tow ball – center 2.attachment point	13.5 in (343.5 mm)

Capacities and Specifications

Long Wheelbase Extended Frame

Measurement	Dimension description	in (mm)
A	wheel center – end of tow ball	61.4 in (1,560 mm)
B	Center of tow ball - side member	16.5 in (418 mm)
C	Inner side of side member	32.9 in (836 mm)
D	Center of tow ball – center 1.attachment point	9.3 in (237 mm)
E	Center of tow ball – center 2.attachment point	13.5 in (343.5 mm)

Extra Long Wheelbase Extended Frame

Measurement	Dimension description	in (mm)
A	wheel center – end of tow ball	78.0 in (1,982 mm)
B	Center of tow ball - side member	16.5 in (418 mm)
C	Inner side of side member	32.9 in (836 mm)
D	Center of tow ball – center 1.attachment point	9.3 in (237 mm)
E	Center of tow ball – center 2.attachment point	13.5 in (343.5 mm)

Note: *The information shown on your vehicle identification plate is dependent upon market requirements.*

VEHICLE IDENTIFICATION PLATE

Note: *Your vehicle identification plate design may vary to that shown.*

Capacities and Specifications

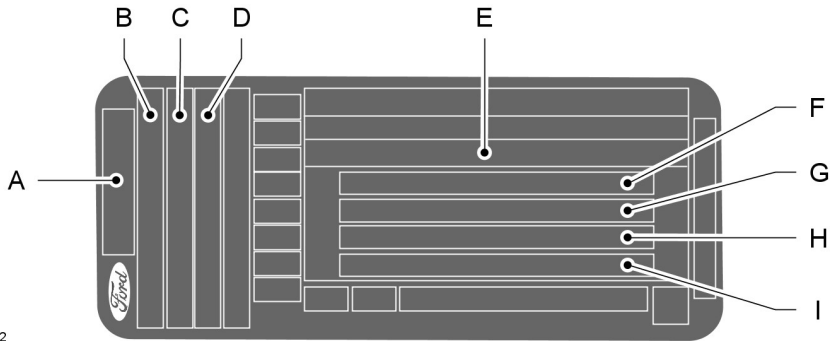

E135662

- A Model
- B Variant
- C Engine designation
- D Engine power and emission level
- E Vehicle identification number
- F Gross vehicle weight
- G Gross train weight
- H Maximum front axle weight
- I Maximum rear axle weight

You can find your vehicle identification number and maximum weights on a plate, which is located at the bottom of the lock side of the passenger door aperture.

Capacities and Specifications

VEHICLE IDENTIFICATION NUMBER

The vehicle identification number is located on the left-hand side of the instrument panel. You will also find it stamped into the right-hand front wheel arch.



E71369

FUEL CONSUMPTION FIGURES

Variant	Urban	Extra-Urban	Combined	CO2 Emissions
	mpg (l/100 km)	mpg (l/100 km)	mpg (l/100 km)	g/km
All vehicles	24.4 - 38.7 (11.6 - 7.3)	32.5 - 47.9 (8.7 - 5.9)	29.1 - 44.1 (9.7 - 6.4)	169 - 255

Audio System

GENERAL INFORMATION

Radio Frequencies and Reception Factors

Radio reception factors	
Distance and Strength	The further you travel away from an FM station, the weaker the signal and the weaker the reception.
Terrain	Hills, mountains, tall buildings, bridges, tunnels, freeway overpasses, parking garages, dense tree foliage and thunderstorms can interfere with the reception.
Station overload	When you pass near a radio transmission tower, a stronger signal can override a weaker signal and can cause interference in the audio system.

CD and CD Player Information

Note: *CD units play commercially pressed 4.75-inch (12 centimeter) audio compact discs only. Due to technical incompatibility, certain recordable and re-recordable compact discs may not function correctly when used in Ford CD players.*

Note: *Do not insert CDs with homemade paper (adhesive) labels into the CD player as the label may peel and cause the CD to become jammed. You should use a permanent felt tip marker rather than adhesive labels on your homemade CDs. Ballpoint pens may damage CDs. Please contact an authorized dealer for further information.*

Note: *Do not use any irregularly shaped discs or discs with a scratch protection film attached.*

Always handle discs by their edges only. Clean the disc with an approved CD cleaner only. Wipe it from the center of the disc toward the edge. Do not clean in a circular motion.

Do not expose discs to direct sunlight or heat sources for extended periods.

MP3 and WMA Track and Folder Structure

Audio systems capable of recognizing and playing MP3 and WMA individual tracks and folder structures work as follows:

- There are two different modes for MP3 and WMA disc playback: MP3 and WMA track mode (system default) and MP3 and WMA folder mode.
- MP3 and WMA track mode ignores any folder structure on the MP3 and WMA disc. The player numbers each MP3 and WMA track on the disc (noted by the MP3 or WMA file extension) from T001 to a maximum of T255. The maximum number of playable MP3 and WMA files may be less depending on the structure of the CD and exact model of radio present.

Audio System

- MP3 and WMA folder mode represents a folder structure consisting of one level of folders. The CD player numbers all MP3 and WMA tracks on the disc (noted by the MP3 or WMA file extension) and all folders containing MP3 and WMA files, from F001 (folder) T001 (track) to F253 T255.
- Creating discs with only one level of folders helps with navigation through the disc files.

If you are burning your own MP3 and WMA discs, it is important to understand how the system reads the structures you create. While various files may be present, (files with extensions other than MP3 and WMA), only files with the MP3 and WMA extension are played; other files are ignored by the system. This enables you to use the same MP3 and WMA disc for a variety of tasks on your work computer, home computer and your in-vehicle system.

In track mode, the system displays and plays the structure as if it were only one level deep (all MP3 and WMA files play, regardless of being in a specific folder). In folder mode, the system only plays the MP3 and WMA files in the current folder.

AUDIO UNIT

WARNING



Driving while distracted can result in loss of vehicle control, crash and injury. We strongly recommend that you use extreme caution when using any device that may take your focus off the road. Your primary responsibility is the safe operation of your vehicle. We recommend against the use of any hand-held device while driving and encourage the use of voice-operated systems when possible. Make sure you are aware of all applicable local laws that may affect the use of electronic devices while driving.

Audio System

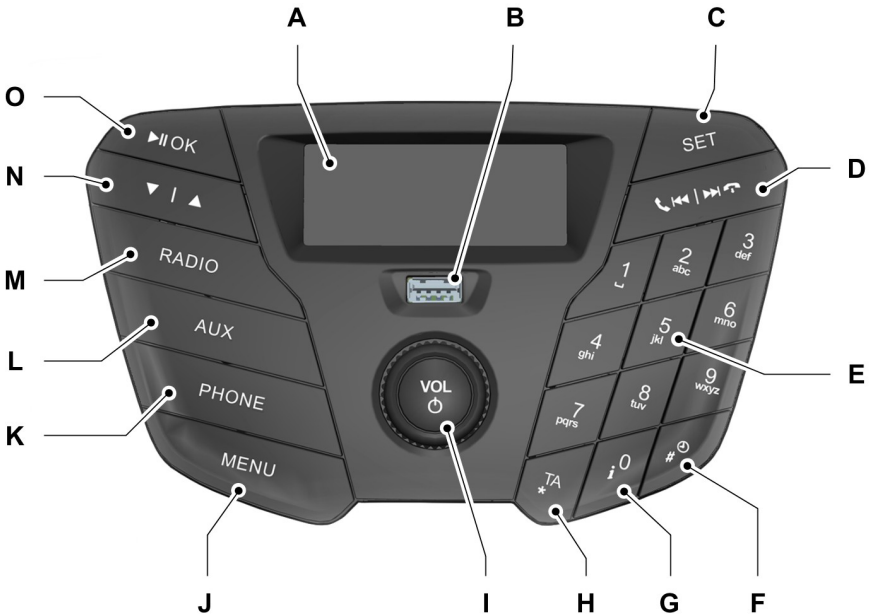

E172221

- A **Display:** Shows the status of the current mode selected.
- B **USB socket:** Insert to play audio from a compatible external device or memory stick.
- C **SET:** Press the button to adjust the sound settings for bass, treble, balance and fade.
- D **Seek up:** Press the button to go to the next radio station up the radio frequency band. Seek tuning will stop at the first radio station it locates. In **AUX** mode, press the button to go to the next track (Bluetooth audio streaming or USB playback only). In **PHONE** mode, press the button to end or reject a phone call.
- D **Seek down:** Press the button to go to the next radio station down the radio frequency band. Seek tuning will stop at the first radio station it locates. In **AUX** mode, press the button to go to the previous track (Bluetooth audio streaming or USB playback only). In **PHONE** mode, press the button to begin or accept a phone call.
- E **Numeric keypad:** Press a button to recall a previously stored radio station. In **PHONE** mode, you can use the numeric keypad to enter a phone number.

Audio System

- F **Clock:** Press the button to select clock setup.
- G **Information:** Press the button to access more information if it does not fit the display.
- H **TA:** Press the button to turn traffic announcements on or off and cancel announcements during an active announcement.
- I **On, Off and Volume:** Press the button to switch the audio system on or off. Turn the dial to adjust the volume.
- J **MENU:** Press the button to access different audio system features, depending on which mode has been selected.
- K **PHONE:** Press the button to access the Bluetooth phone feature of the system by pressing **PHONE** then **MENU**. When paired further presses of this button will display phone name, signal strength and the battery level.
- L **AUX:** Press the button to access Bluetooth audio streaming, USB or Aux input playback.
- M **RADIO:** Press the button to select different radio frequency bands. Press to cancel the menu or list browsing.
- N **Cursor up and down:** Press a button to scroll through on-screen choices. In radio mode press to manual tune.
- O **OK, Play and Pause:** Press the button to confirm on-screen selections. Press to play or pause during playback with compatible external devices.

Set Button

This will allow you to adjust the sound settings, for example bass, treble, balance and fade.

1. Press the **SET** button until the required setting is displayed.
2. Use the up and down arrow buttons to select the required level.
3. Press the **OK** button to confirm the new settings.

Radio Button

Press the **RADIO** button to select from the frequency bands available.

You can use the button to return to radio reception when you have been listening to another source.

Station Tuning Control

Seek Tuning

Select a frequency band and briefly press the seek up or seek down button. Seek tuning will stop at the first radio station it locates.

Manual Tuning

Use the up and down arrow buttons to tune down or up the frequency band in small increments or press and hold to increment quickly, until you find a station you want to listen to.

Station Preset Buttons

This feature allows you to store your favorite stations. They can be recalled by selecting the appropriate frequency band and pressing one of the preset buttons.

Audio System

1. Select a frequency band.
2. Tune to the station required.
3. Press and hold one of the preset buttons. A progress bar and message will appear. When the progress bar completes the station has been stored. The audio unit will also mute momentarily as confirmation.

You can repeat this on each frequency band and for each preset button.

Note: *When you drive to another part of the country, stations that broadcast on alternative frequencies, and are stored on preset buttons, may be updated with the correct frequency and station name for that area.*

Traffic Information Control

Many stations that broadcast on the FM frequency band have a TP code to signify that they carry traffic program information.

Turning Traffic Announcements On and Off

Before you can receive traffic announcements, you must press either the **TA** or **TRAFFIC** button. A TA display will appear to show the feature is switched on.

If you are already tuned to a station that broadcasts traffic information, TP will also be displayed. Otherwise the unit will search for a traffic program.

When traffic information is broadcast, it will automatically interrupt normal radio or device playback.

If a non-traffic station is selected or recalled using a preset button, the audio unit will remain on that station unless **TA** or **TRAFFIC** is turned off, then on again.

Note: *If traffic announcement is on and you select a preset or manual tune to a non traffic announcement station no traffic announcements will be heard.*

Note: *When you are listening to a non traffic announcement station and turn traffic announcement off and on again a TP seek will occur.*

Traffic Announcement Volume

Traffic announcements interrupt normal broadcasts at a preset minimum level that is usually louder than normal listening volumes.

To adjust the preset volume use the volume control to make the necessary adjustment during an incoming traffic announcement broadcast. The display will show the level selected.

Ending Traffic Announcements

The audio unit will return to normal operation at the end of each traffic announcement. To end the announcement prematurely, press **TA** or **TRAFFIC** during the announcement.

Note: *If you press **TA** or **TRAFFIC** at any other time it will switch all announcements off.*

News Broadcasts

The audio unit may interrupt normal reception to broadcast news bulletins from stations on the FM frequency band, radio data system or other enhanced network linked stations.

The display will indicate there is an incoming announcement, during news broadcasts. When the audio unit interrupts for a news broadcast the preset volume level will be the same as traffic announcements.

1. Press the **MENU** button.
2. Scroll to the news option and turn on or off with the up and down arrow buttons.
3. Press the **OK** button to return.

Audio System

Alternative Frequencies

The majority of programs that broadcast on the FM frequency band have a program identification code, it can be recognized by audio units.

When your vehicle moves from one transmission area to another with the alternative frequencies tuning switched on, this function will search for the strongest station signal.

Under certain conditions, however, alternative frequencies tuning may temporarily disrupt normal reception.

When selected, the unit continually evaluates signal strength and, if a better signal becomes available, the unit will switch to that alternative. It mutes while it checks a list of alternative frequencies and if necessary, it will search once across the selected frequency band for a genuine alternative frequency.

It will restore radio reception when it finds one or if one is not found, the unit will return to the original stored frequency.

When selected, AF will appear in the display.

1. Press the **MENU** button.
2. Scroll to the AF option and turn to auto or off with the up and down arrow buttons.
3. Press the **OK** button to return.

Regional Mode

Regional mode controls the behavior of alternative frequencies switching between regionally related networks of a parent broadcaster. A broadcaster may run a fairly large network across a large part of the country. At various times of the day this

large network may be broken down into a number of smaller regional networks, typically centered on major towns or cities. When the network is not split into regional variants, the whole network carries the same programming.

Regional mode on: This prevents random alternative frequency switches when neighboring regional networks are not carrying the same programming.

Regional mode off: This allows a larger coverage area if neighboring regional networks are carrying the same programming, but can cause random alternative frequency switches if they are not.

1. Press the **MENU** button.
2. Scroll to the region option and turn on or off with the up and down arrow buttons.
3. Press the **OK** button to return.

Phone

This section describes the functions and features of the Bluetooth cell phone hands free system.

The Bluetooth cell phone part of the system provides interaction with the audio system and your cell phone. It allows you to use the audio system to make and receive calls without having to hold your cell phone.

Note: *Using the system with the engine off will drain the battery.*

Audio System

Note: As no common agreement exists, cell phone manufacturers are able to implement a variety of profiles in their Bluetooth devices. Because of this, an incompatibility can occur between the phone and hands free system, which in some cases may significantly degrade the system performance. To avoid this situation, only recommended phones should be used. To check if your cell phone is compatible, refer to the cell phone user manual or visit the regional Ford website.

Bluetooth Setup

Before you can use your cell phone with your vehicle it must be paired to the audio system.

The following procedure is required before an initial Bluetooth phone connection can be made.

Note: Up to five Bluetooth devices can be paired to the system.

Note: If there is an ongoing call when the phone in use is selected as the new active phone, the call is transferred to the vehicle audio system.

Note: Even if connected to the system, your phone can still be used in the usual way.

Note: A call will be disconnected if the audio unit is switched off. If the ignition is switched off the phone call will remain in progress.

Message	Description and Action
ADD DEVICE	<ol style="list-style-type: none"> 1. Press the PHONE button and then keep pressing the MENU button to scroll to the screen display term. Press the OK button. 2. Press the OK button again and note the six digit number displayed. 3. Search for Bluetooth devices using the cell phone. For information on phone settings, refer to your cell phone user manual. 4. Select FORD AUDIO from the list of Bluetooth devices found by your phone. 5. Enter the six digit number into your cell phone when prompted to pair the audio system and cell phone.
SET PRIMARY	<ol style="list-style-type: none"> 1. Once pairing has been successful the screen display term will be shown on the audio display. 2. Press the OK button twice to confirm your cell phone as the primary device for all future connections.
LOAD PHONEBK	<ol style="list-style-type: none"> 1. The screen display term will then be displayed on the audio unit. Press the OK button twice to confirm that the contents of your phonebook are downloaded to the system. 2. The Bluetooth device name is displayed on the audio unit.

Audio System

Phonebook Downloading

If your phonebook was not downloaded during initial Bluetooth pairing follow this process:

1. Press the **PHONE** button and then keep pressing the **MENU** button to scroll to the load phonebook option.
2. Press the **OK** button.

Deleting a Paired Device or Cell Phone

To remove a paired device follow this process:

1. Press the **PHONE** button and then keep pressing the **MENU** button to scroll to the delete device option.
2. Press the **OK** button. The first paired device name will be shown. Scroll to the required device name using the up and down arrow buttons. Select delete all to erase all paired devices.
3. Press the **OK** button multiple times to remove the device from the audio unit.

Privacy Mode

You can transfer a call from hands free to private mode during an active call.

Press the **MENU** button until the privacy option appears, then press the **OK** button to transfer. To return to hands free mode, press the dial button.

Phone Menu Options

Press the **PHONE** button to select phone mode. Press the **PHONE** button again to display information such as phone name, signal strength and battery level.

When in phone mode, press the **MENU** button to scroll through the various phone options.

Phone options
REDIAL
PHONEBOOK
CALL HISTORY
ADD DEVICE
SEL DEVICE
SET PRIMARY
DEL DEVICE
BLUETOOTH
BLUETOOTH OFF
LOAD PHONEBK

Press the **OK** button to select the required option, and use the up and down arrows to change features.

Making and Receiving Calls

Outgoing calls can be made by:

- Entering a number using the numeric keypad.
- Selecting a contact from the downloaded phonebook.
- Selecting a number or contact from the call history log.
- Using quick dial by pressing one of the radio preset buttons.
- Using the redial function.
- Using the cell phone.

Incoming calls can be answered by:

- Pressing the call pickup button on the audio unit.
- Using the cell phone.

Calls can be rejected using the end call button on the audio unit, or by using the cell phone directly.

Audio System

USB

The audio unit supports a range of external devices. Once connected, control of the external device is possible through the audio unit.

Note: Only use USB mass-storage device compliant devices.

Note: Always switch the audio unit to a different source before unplugging the USB device, for example radio.

Note: Do not use USB hubs or splitters.

Note: The system is only designed to recognize and read suitable audio files from a USB device that conforms to the USB Mass-Storage device class or an iPod. Not all available USB devices can be guaranteed to function with the system.

Note: It is possible to connect compatible devices with a trailing USB lead as well as those that plug into the USB socket directly, for example USB memory sticks or pen drives.

Note: Some USB devices with a higher power consumption may not be compatible, for example some larger hard drives.

Note: Access time to read the files on the external device will vary depending upon factors such as the file structure, size and device content.

Operating the USB Device

Connect the device to the audio unit.

Select the USB device as the audio source by pressing the **AUX** button until the USB screen appears in the display. After first connecting the USB device, the first track within the first folder will start to play automatically. Following audio source switching, the position of playback on the USB device is remembered.

Press the seek up and down keys to skip forward or backward through tracks. Press and hold to fast forward and reverse through the track.

Message	Description
AUTOPL	USB playback will start automatically when you connect a compatible device. To turn this feature off, select this option and turn off using the menu function.

iPod

Connect the iPod to the audio unit.

Select the iPod as the audio source by pressing the **AUX** button until the iPod option appears in the display. After first connecting the iPod, the first track within the first folder will start to play automatically. Following audio source switching, the position of playback on the iPod is remembered.

Press the seek up and down keys to skip backward and forward through tracks.

Press and hold the seek keys to enable fast rewind or fast forward through track content.

Various functions may be controlled from the audio unit including:

- Next and previous track select.
- Track seek.
- Shuffle.
- Repeat.

Bluetooth Audio Streaming

Compatible Bluetooth devices can be connected to the audio unit to playback using the vehicle audio system.

Audio System

Select the device as the audio source by pressing the **AUX** button until the Bluetooth audio option appears in the display.

The device playback can be controlled using the audio unit buttons play, pause, next and previous track.

Note: *Make sure the device is paired before using this feature.*

Declaration of Conformity

Hereby, Visteon Corporation, declares that this Bluetooth enabled car radio is in compliance with the essential requirements and other relevant provisions of Directive 1999/5/EC.

EC Declaration of Conformity

Hereby,

Name of manufacturer: Palmela Electronics – Visteon Corporation
Address: Estrada Nacional 252, KM 12 Volta Da Pedra
City: Palmela
Country: Portugal

declares that this equipment:

Product description: VE-BT001 - ULC Medialess Radio – Bluetooth enabled car radio
Type designation(s): VE-BT001
Trademark: Visteon

is in compliance with the essential requirements and other relevant provisions of Directive 55013:2001 + A1:2003 +A2:2006
EN 301 489 -1, EN 301 489 -17
EN 300 328 v1.7.1
EN 60950-1 :2006 + All :2009 +A1:2010+A12:2011 IEG 60950-1 :2005 (2nd Edition):AM 1 :2009

E167208

Audio System

AUDIO UNIT - VEHICLES WITH: AM/FM/CD

WARNING



Driving while distracted can result in loss of vehicle control, crash and injury. We strongly recommend that you use extreme caution when using any device that may take your focus off the road. Your primary responsibility is the safe operation of your vehicle. We recommend against the use of any hand-held device while driving and encourage the use of voice-operated systems when possible. Make sure you are aware of all applicable local laws that may affect the use of electronic devices while driving.

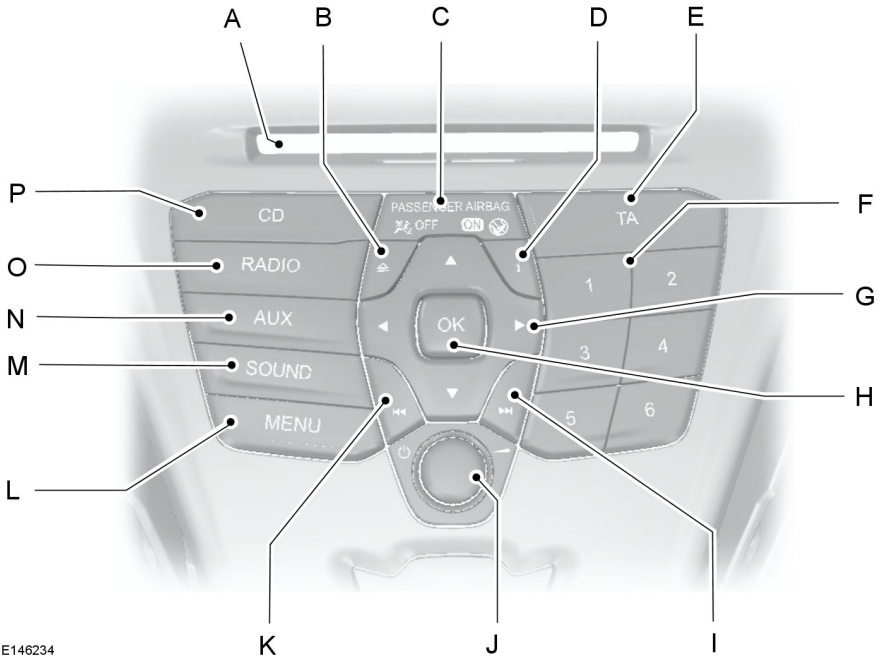

E146234

- A **CD slot:** Where you insert a CD.
- B **Eject:** Press the button to eject a CD.

Audio System

- C **Passenger airbag information:** Informs you when the passenger airbag is either on or off.
- D **INFO:** Press the button to access radio, CD, USB and iPod information.
- E **TA:** Press the button to turn traffic announcements on or off and cancels announcements during an active announcement.
- F **Numeric Keypad:** Press a button to recall a previously stored radio station.
- G **Cursor arrows:** Press a button to scroll through on-screen choices.
- H **OK:** Press the button to confirm on-screen selections.
- I **Seek up:** Press the button to go to the next radio station up the radio frequency band. Seek tuning will stop at the first radio station it locates. While listening to a CD, press the button to go to the next track.
- J **On, Off and Volume:** Press the button to switch the audio system on or off. Turn the dial to adjust the volume.
- K **Seek down:** Press the button to go to the next radio station down the radio frequency band. Seek tuning will stop at the first radio station it locates. While listening to a CD, press the button to go to the previous track.
- L **MENU:** Press the button to access different audio system features.
- M **SOUND:** Press the button to adjust the sound settings for bass, treble, middle, balance and fade.
- N **AUX:** Press the button to access the AUX and SYNC features, it will also cancel the menu or list browsing.
- O **RADIO:** Press the button to select different radio frequency bands, it will also cancel the menu or list browsing.
- P **CD:** Press the button to change source to CD, it will also cancel the menu or list browsing.

Sound Button

This will allow you to adjust the sound settings (for example bass, middle and treble).

1. Press the **SOUND** button.
2. Use the up and down arrow buttons to select the required setting.
3. Use the left and right arrow buttons to make the necessary adjustment. The display indicates the level selected.
4. Press the **OK** button to confirm the new settings.

Radio Button

Press the **RADIO** button to select from the frequency bands available.

You can use the button to return to radio reception when you have been listening to another source.

Alternatively, press the left arrow button to display the available frequency bands. Scroll to the required frequency band and press **OK**.

Audio System

Station Tuning Control

Seek Tuning

Select a frequency band and briefly press the seek up or seek down button. Seek tuning will stop at the first radio station it locates.

Manual Tuning

1. Press the **MENU** button.
2. Select radio mode and then manual tune.
3. Use the left and right arrow buttons to tune down or up the frequency band in small increments or press and hold to increment quickly, until you find a station you want to listen to.
4. Press **OK** to continue listening to a station.

Scan Tuning

Scan allows you to listen to a few seconds of each station detected.

1. Press the **MENU** button.
2. Select radio mode and then scan.
3. Use the seek buttons to scan up or down the selected frequency band.
4. Press **OK** to continue listening to a station.

Station Preset Buttons

This feature allows you to store your favorite stations, they can be recalled by selecting the appropriate frequency band and pressing one of the preset buttons.

1. Select a frequency band.
2. Tune to the station required.

3. Press and hold one of the preset buttons. A progress bar and message will appear. When the progress bar completes the station has been stored. The audio unit will also mute momentarily as confirmation.

You can repeat this on each frequency band and for each preset button.

Note: *When you drive to another part of the country, stations that broadcast on alternative frequencies, and are stored on preset buttons, may be updated with the correct frequency and station name for that area.*

Autostore Control

Note: *This will store up to a maximum of the six strongest signals available, either from the AM or the FM frequency band, and overwrite the previously stored stations. You can also store stations manually in the same way as other frequency bands.*

- Press the **MENU** button, select radio mode and press autostore.
- When the search is complete, sound is restored and the strongest signals are stored on the autostore presets.

Traffic Information Control

Many stations that broadcast on the FM frequency band have a TP code to signify that they carry traffic program information.

Turning Traffic Announcements On and Off

Before you can receive traffic announcements, you must press either the **TA** or **TRAFFIC** button. A TA display will appear to show the feature is switched on.

If you are already tuned to a station that broadcasts traffic information, **TP** will also be displayed. Otherwise the unit will search for a traffic program.

Audio System

When traffic information is broadcast, it will automatically interrupt normal radio or CD playback and a message will appear in the display.

If a non-traffic station is selected or recalled using a preset button, the audio unit will remain on that station unless **TA** or **TRAFFIC** is turned off, then on again.

Note: *If traffic announcement is on and you select a preset or manual tune to a non traffic announcement station no traffic announcements will be heard.*

Note: *When you are listening to a non traffic announcement station and turn traffic announcement off and on again a TP seek will occur.*

Traffic Announcement Volume

Traffic announcements interrupt normal broadcasts at a preset minimum level that is usually louder than normal listening volumes.

To adjust the preset volume:

- Use the volume control to make the necessary adjustment during an incoming traffic announcement broadcast. The display will show the level selected.

Ending Traffic Announcements

The audio unit will return to normal operation at the end of each traffic announcement. To end the announcement prematurely, press **TA** or **TRAFFIC** during the announcement.

Note: *If you press **TA** or **TRAFFIC** at any other time it will switch all announcements off.*

Automatic Volume Control

When available, automatic volume control adjusts the volume level to compensate for engine noise and road speed noise.

Press the **MENU** button.

Action	Description
1	Audio settings
2	Adaptive volume

1. Use the left or right arrow button to adjust the setting.
2. Press the **OK** button to confirm your selection.
3. Press the **MENU** button to return.

News Broadcasts

The audio unit may interrupt normal reception to broadcast news bulletins from stations on the FM frequency band, radio data system or other enhanced network linked stations.

The display will indicate there is an incoming announcement, during news broadcasts. When the audio unit interrupts for a news broadcast the preset volume level will be the same as traffic announcements.

Press the **MENU** button.

Action	Description
1	Audio settings
2	News

1. Turn on or off with the **OK** button.
2. Press the **MENU** button to return.

Alternative Frequencies

The majority of programs that broadcast on the FM frequency band have a program identification code, it can be recognized by audio units.

Audio System

When your vehicle moves from one transmission area to another with the alternative frequencies tuning switched on, this function will search for the strongest station signal.

Under certain conditions, however, alternative frequencies tuning may temporarily disrupt normal reception.

When selected, the unit continually evaluates signal strength and if a better signal becomes available, the unit will switch to that alternative. It mutes while it checks a list of alternative frequencies and if necessary, it will search once across the selected frequency band for a genuine alternative frequency.

It will restore radio reception when it finds one or if one is not found, the unit will return to the original stored frequency.

When selected, AF may appear in the display.

Press the **MENU** button.

Action	Description
1	Audio settings
2	Alt. frequency

1. Turn on or off with the **OK** button.
2. Press the **MENU** button to return.

Regional Mode

Regional mode controls the behavior of alternative frequencies switching between regionally related networks of a parent broadcaster. A broadcaster may run a fairly large network across a large part of the country. At various times of the day this

large network may be broken down into a number of smaller regional networks, typically centered on major towns or cities. When the network is not split into regional variants, the whole network carries the same programming.

Regional mode on: This prevents random alternative frequency switches when neighboring regional networks are not carrying the same programming.

Regional mode off: This allows a larger coverage area if neighboring regional networks are carrying the same programming, but can cause random alternative frequency switches if they are not.

Press the **MENU** button.

Action	Description
1	Audio settings
2	RDS regional

1. Turn on or off with the **OK** button.
2. Press the **MENU** button to return.

AUDIO UNIT - VEHICLES WITH: SYNC/NAVIGATION SYSTEM

WARNING



Driving while distracted can result in loss of vehicle control, crash and injury. We strongly recommend that you use extreme caution when using any device that may take your focus off the road. Your primary responsibility is the safe operation of your vehicle. We recommend against the use of any hand-held device while driving and encourage the use of voice-operated systems when possible. Make sure you are aware of all applicable local laws that may affect the use of electronic devices while driving.

Audio System

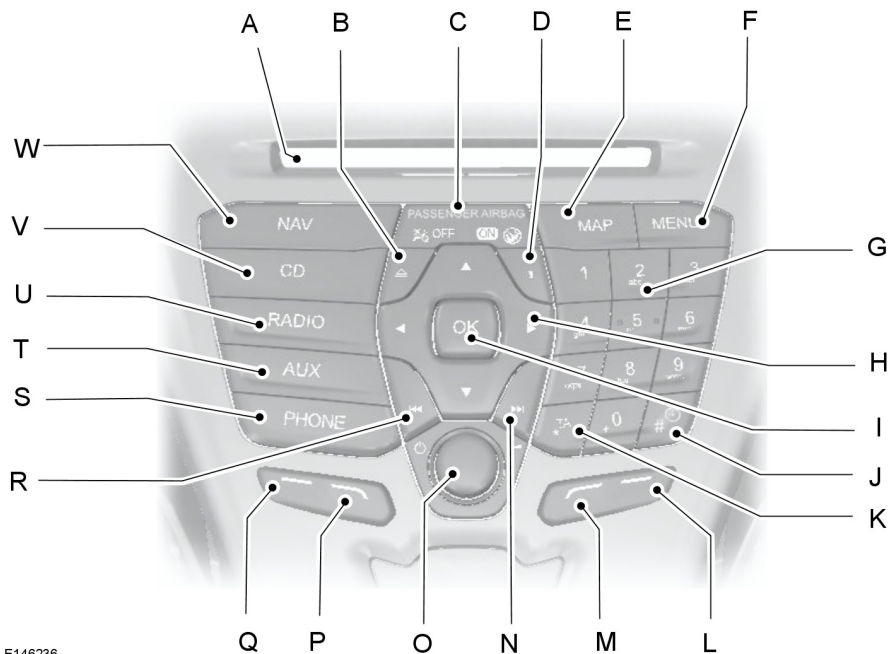

E146236

- A **CD slot:** Where you insert a CD.
- B **Eject:** Press the button to eject a CD.
- C **Passenger airbag information:** Informs you when the passenger airbag is either on or off.
- D **INFO:** Press the button to access radio, CD, USB, iPod and Navigation information. If Navigation has been selected, pressing this button will show details of your current location or journey.
- E **MAP:** Press the button to access map features.
- F **MENU:** Press the button to access different audio system features.
- G **Numeric keypad** Press a button to recall a previously stored radio station. In **PHONE** mode, you can use the numeric keypad to enter a phone number.
- H **Cursor arrows:** Press a button to scroll through on-screen choices.
- I **OK:** Press the button to confirm on-screen selections.

Audio System

- J **Clock:** Press the button to select clock setup.
- K **TA:** Press the button to turn traffic announcements on or off and cancel announcements during an active announcement. If Navigation has been selected pressing this button takes you to the Traffic menu.
- L **Function button 4:** Press the button to select different functions of the audio system depending on which mode you are in, for example radio or CD.
- M **Function button 3:** Press the button to select different functions of the audio system depending on which mode you are in, for example radio or CD.
- N **Seek up:** Press the button to go to the next radio station up the radio frequency band. Seek tuning will stop at the first radio station it locates. While listening to a CD, press the button to go to the next track. In **PHONE** mode, press the button to end or reject a phone call.
- O **On, Off and Volume:** Press the button to switch the audio system on or off. Turn the dial to adjust the volume.
- P **Function button 2:** Press the button to select different functions of the audio system depending on which mode you are in, for example radio or CD.
- Q **Function button 1:** Press the button to select different functions of the audio system depending on which mode you are in, for example radio or CD.
- R **Seek down:** Press the button to go to the next radio station down the radio frequency band. Seek tuning will stop at the first radio station it locates. While listening to a CD, press the button to go to the previous track. In **PHONE** mode, press the button to begin or accept a phone call.
- S **PHONE:** Press the button to access the phone feature of the SYNC system by pressing **PHONE** then **MENU**.
- T **AUX:** Press the button to access the AUX and SYNC features, it will also cancel the menu or list browsing.
- U **RADIO:** Press the button to select different radio frequency bands, it will also cancel the menu or list browsing.
- V **CD:** Press the button to change source to CD, it will also cancel the menu or list browsing.
- W **NAV:** Press the button to access the navigation system.

Sound Button

This will allow you to adjust the sound settings, for example bass, middle and treble.

1. Press the sound button.
2. Use the up and down arrow buttons to select the required setting.

3. Use the left and right arrow buttons to make the necessary adjustment. The display indicates the level selected.
4. Press the **OK** button to confirm the new settings.

Radio Button

Press the **RADIO** button to select from the frequency bands available.

Audio System

You can use the button to return to radio reception when you have been listening to another source.

Alternatively, press the left arrow button to display up or available frequency bands. Scroll to the required frequency band and press **OK**.

Station Tuning Control

Seek Tuning

Select a frequency band and briefly press the seek up or seek down button. Seek tuning will stop at the first radio station it locates.

Manual Tuning

1. Press function button 2.
2. Use the left and right arrow buttons to tune down or up the frequency band in small increments or press and hold to increment quickly, until you find a station you want to listen to.
3. Press **OK** to continue listening to a station.

Scan Tuning

Scan allows you to listen to a few seconds of each station detected.

1. Press function button 3.
2. Use the seek buttons to scan up or down the selected frequency band.
3. Press function button 3 again or **OK** to continue listening to a station.

Station Preset Buttons

This feature allows you to store your favorite stations, they can be recalled by selecting the appropriate frequency band and pressing one of the preset buttons.

1. Select a frequency band.
2. Tune to the station required.

3. Press and hold one of the preset buttons. A progress bar and message will appear. When the progress bar completes the station has been stored. The audio unit will also mute momentarily as confirmation.

You can repeat this on each frequency band and for each preset button.

Note: *When you drive to another part of the country, stations that broadcast on alternative frequencies, and are stored on preset buttons, may be updated with the correct frequency and station name for that area.*

Autostore Control

Note: *This will store up to a maximum of the 10 strongest signals available, either from the AM or the FM frequency band, and overwrite the previously stored stations. You can also store stations manually in the same way as other frequency bands.*

Note: *You must select either **FM AST** or **AM AST** to use this function.*

- Press the **MENU** button, select audio mode then press and hold the **RADIO** button.
- When the search is complete, sound is restored and the strongest signals are stored on the autostore presets.

Traffic Information Control

Many stations that broadcast on the FM frequency band have a TP code to signify that they carry traffic program information.

Turning Traffic Announcements On and Off

Before you can receive traffic announcements, you must press either the **TA** or **TRAFFIC** button. A TA display will appear to show the feature is switched on.

Audio System

If you are already tuned to a station that broadcasts traffic information, TP will also be displayed. Otherwise the unit will search for a traffic program.

When traffic information is broadcast, it will automatically interrupt normal radio or CD playback and a message will appear in the display.

If a non-traffic station is selected or recalled using a preset button, the audio unit will remain on that station unless **TA** or **TRAFFIC** is turned off, then on again.

Note: *If traffic announcement is on and you select a preset or manual tune to a non traffic announcement station no traffic announcements will be heard.*

Note: *When you are listening to a non traffic announcement station and turn traffic announcement off and on again a TP seek will occur.*

Traffic Announcement Volume

Traffic announcements interrupt normal broadcasts at a preset minimum level that is usually louder than normal listening volumes.

To adjust the preset volume:

- Use the volume control to make the necessary adjustment during an incoming traffic announcement broadcast. The display will show the level selected.

Ending Traffic Announcements

The audio unit will return to normal operation at the end of each traffic announcement. To end the announcement prematurely, press **TA** or **TRAFFIC** during the announcement.

Note: *If you press **TA** or **TRAFFIC** at any other time it will switch all announcements off.*

Automatic Volume Control

When available, automatic volume control adjusts the volume level to compensate for engine noise and road speed noise.

Press the **MENU** button.

Action	Message
1	Audio settings
2	Adaptive volume

1. Use the left or right arrow button to adjust the setting.
2. Press the **OK** button to confirm your selection.
3. Press the **MENU** button to return.

Digital Signal Processing

Digital Signal Processing Occupancy

This feature takes into account the differences in distance from the various speakers in your vehicle to each seat. You must select the correct sitting position for the audio to be correctly set.

Digital Signal Processing Equalizer

Select the music category that most suits your listening preference. The audio output will change to enhance the particular style of music chosen.

Changing the Digital Signal Processing Settings

Press the **MENU** button.

Action	Message
1	Audio settings

1. Scroll to the required digital signal processing function.

Audio System

2. Use the up and down arrow buttons to select the required setting.
3. Press the **OK** button to confirm your selection.
4. Press the **MENU** button to return.

News Broadcasts

The audio unit may interrupt normal reception to broadcast news bulletins from stations on the FM frequency band, radio data system or other enhanced network linked stations.

The display will indicate there is an incoming announcement, during news broadcasts. When the audio unit interrupts for a news broadcast the preset volume level will be the same as traffic announcements.

Press the **MENU** button.

Action	Message
1	Audio settings
2	News

1. Turn on or off with the **OK** button.
2. Press the **MENU** button to return.

Alternative Frequencies

The majority of programs that broadcast on the FM frequency band have a program identification code, it can be recognized by audio units.

When your vehicle moves from one transmission area to another with the alternative frequencies tuning switched on, this function will search for the strongest station signal.

Under certain conditions, however, alternative frequencies tuning may temporarily disrupt normal reception.

When selected, the unit continually evaluates signal strength and, if a better signal becomes available, the unit will switch to that alternative. It mutes while it checks a list of alternative frequencies and if necessary, it will search once across the selected frequency band for a genuine alternative frequency.

It will restore radio reception when it finds one or if one is not found, the unit will return to the original stored frequency.

When selected, AF may appear in the display.

Press the **MENU** button.

Action	Message
1	Audio settings
2	Alt. frequency

1. Turn on or off with the **OK** button.
2. Press the **MENU** button to return.

Regional Mode

Regional mode controls the behavior of alternative frequencies switching between regionally related networks of a parent broadcaster. A broadcaster may run a fairly large network across a large part of the country. At various times of the day this large network may be broken down into a number of smaller regional networks, typically centered on major towns or cities. When the network is not split into regional variants, the whole network carries the same programming.

Regional mode on: This prevents random alternative frequency switches when neighboring regional networks are not carrying the same programming.

Audio System

Regional mode off: This allows a larger coverage area if neighboring regional networks are carrying the same programming, but can cause random alternative frequency switches if they are not.

Press the **MENU** button.

Action	Message
1	Audio settings
2	RDS regional

1. Turn on or off with the **OK** button.
2. Press the **MENU** button to return.

AUDIO UNIT - VEHICLES WITH: SYNC/AM/FM/CD

WARNING



Driving while distracted can result in loss of vehicle control, crash and injury. We strongly recommend that you use extreme caution when using any device that may take your focus off the road. Your primary responsibility is the safe operation of your vehicle. We recommend against the use of any hand-held device while driving and encourage the use of voice-operated systems when possible. Make sure you are aware of all applicable local laws that may affect the use of electronic devices while driving.

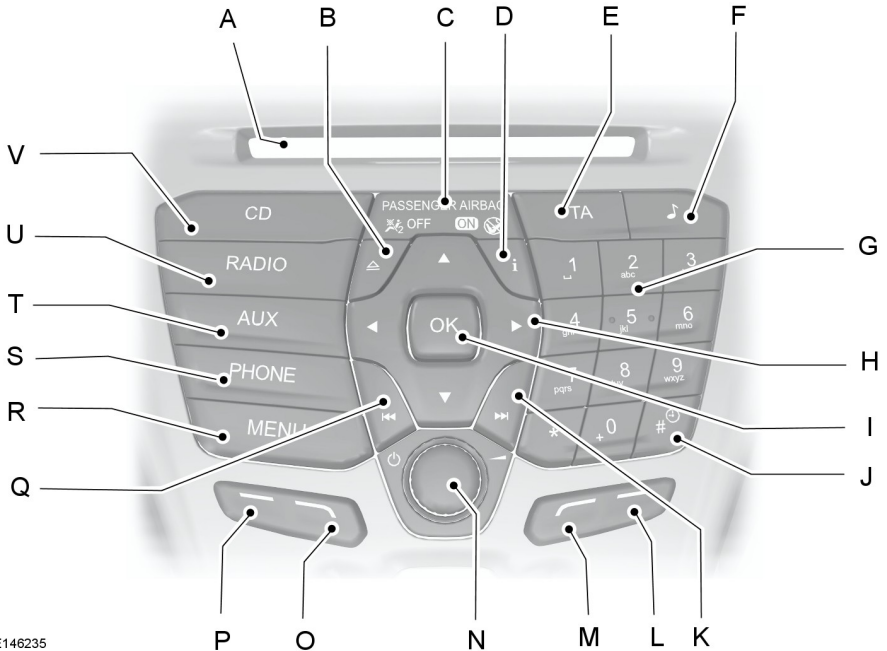

E146235

Audio System

- A **CD slot:** Where you insert a CD.
- B **Eject:** Press the button to eject a CD.
- C **Passenger airbag information:** Informs you when the passenger airbag is either on or off.
- D **INFO:** Press the button to access radio, CD, USB and iPod information.
- E **TA:** Press the button to turn traffic announcements on or off and cancel announcements during an active announcement.
- F **SOUND:** Press the button to adjust the sound settings for bass, treble, middle, balance and fade.
- G **Numeric keypad:** Press a button to recall a previously stored radio station. In **PHONE** mode, you can use the numeric keypad to enter a phone number.
- H **Cursor arrows:** Press a button to scroll through on-screen choices.
- I **OK:** Press the button to confirm on-screen selections.
- J **Clock:** Press the button to select clock setup.
- K **Seek up:** Press the button to go to the next radio station up the radio frequency band. Seek tuning will stop at the first radio station it locates. While listening to a CD, press the button to go to the next track. In **PHONE** mode, press the button to end or reject a phone call.
- L **Function button 4:** Press the button to select different functions of the audio system depending on which mode you are in, for example radio or CD.
- M **Function button 3:** Press the button to select different functions of the audio system depending on which mode you are in, for example radio or CD.
- N **On, Off and Volume:** Press the button to switch the audio system on or off. Turn the dial to adjust the volume.
- O **Function button 2:** Press the button to select different functions of the audio system depending on which mode you are in, for example radio or CD.
- P **Function button 1:** Press the button to select different functions of the audio system depending on which mode you are in, for example radio or CD.
- Q **Seek down:** Press the button to go to the next radio station down the radio frequency band. Seek tuning will stop at the first radio station it locates. While listening to a CD, press the button to go to the previous track. In **PHONE** mode, press the button to begin or accept a phone call.
- R **MENU:** Press the button to access different audio system features.
- S **PHONE:** Press the button to access the phone feature of the SYNC system by pressing **PHONE** then **MENU**.
- T **AUX:** Press the button to access the AUX and SYNC features, it will also cancel the menu or list browsing.

Audio System

- U **RADIO:** Press the button to select different radio frequency bands, it will also cancel the menu or list browsing.
- V **CD:** Press the button to change source to CD, it will also cancel the menu or list browsing.

Sound Button

This will allow you to adjust the sound settings for bass, treble, middle, balance and fade.

1. Press the sound button.
2. Use the up and down arrow buttons to select the required setting.
3. Use the left and right arrow buttons to make the necessary adjustment. The display indicates the level selected.
4. Press the **OK** button to confirm the new settings.

Radio Button

Press the **RADIO** button to select from the frequency bands available.

You can use the button to return to radio reception when you have been listening to another source.

Alternatively, press the left arrow button to display the available frequency bands. Scroll to the required frequency band and press **OK**.

Station Tuning Control

Seek Tuning

Select a frequency band and briefly press the seek up or seek down button. Seek tuning will stop at the first radio station it locates.

Manual Tuning

1. Press function button 2.

2. Use the left and right arrow buttons to tune down or up the frequency band in small increments or press and hold to increment quickly, until you find a station you want to listen to.
3. Press **OK** to continue listening to a station.

Scan Tuning

Scan allows you to listen to a few seconds of each station detected.

1. Press function button 3.
2. Use the seek buttons to scan up or down the selected frequency band.
3. Press function button 3 again or **OK** to continue listening to a station.

Station Preset Buttons

This feature allows you to store your favorite stations, they can be recalled by selecting the appropriate frequency band and pressing one of the preset buttons.

1. Select a frequency band.
2. Tune to the station required.
3. Press and hold one of the preset buttons. A progress bar and message will appear. When the progress bar completes the station has been stored. The audio unit will also mute momentarily as confirmation.

You can repeat this on each frequency band and for each preset button.

Audio System

Note: When you drive to another part of the country, stations that broadcast on alternative frequencies, and are stored on preset buttons, may be updated with the correct frequency and station name for that area.

Autostore Control

Note: This will store up to a maximum of the 10 strongest signals available, either from the AM or the FM frequency band, and overwrite the previously stored stations. You can also store stations manually in the same way as other frequency bands.

- Press the **MENU** button, select audio mode then press and hold the **RADIO** button.
- When the search is complete, sound is restored and the strongest signals are stored on the autostore presets.

Traffic Information Control

Many stations that broadcast on the FM frequency band have a TP code to signify that they carry traffic program information.

Turning Traffic Announcements On and Off

Before you can receive traffic announcements, you must press either the **TA** or **TRAFFIC** button. A TA display will appear to show the feature is switched on.

If you are already tuned to a station that broadcasts traffic information, TP will also be displayed. Otherwise the unit will search for a traffic program.

When traffic information is broadcast, it will automatically interrupt normal radio or CD playback and a message will appear in the display.

If a non-traffic station is selected or recalled using a preset button, the audio unit will remain on that station unless **TA** or **TRAFFIC** is turned off, then on again.

Note: If traffic announcement is on and you select a preset or manual tune to a non traffic announcement station no traffic announcements will be heard.

Note: When you are listening to a non traffic announcement station and turn traffic announcement off and on again a TP seek will occur.

Traffic Announcement Volume

Traffic announcements interrupt normal broadcasts at a preset minimum level that is usually louder than normal listening volumes.

To adjust the preset volume:

- Use the volume control to make the necessary adjustment during an incoming traffic announcement broadcast. The display will show the level selected.

Ending Traffic Announcements

The audio unit will return to normal operation at the end of each traffic announcement. To end the announcement prematurely, press **TA** or **TRAFFIC** during the announcement.

Note: If you press **TA** or **TRAFFIC** at any other time it will switch all announcements off.

Automatic Volume Control

When available, automatic volume control adjusts the volume level to compensate for engine noise and road speed noise.

Press the **MENU** button.

Audio System

Action	Message
1	Audio settings
2	Adaptive volume

1. Use the left or right arrow button to adjust the setting.
2. Press the **OK** button to confirm your selection.
3. Press the **MENU** button to return.

News Broadcasts

The audio unit may interrupt normal reception to broadcast news bulletins from stations on the FM frequency band, radio data system or other enhanced network linked stations.

The display will indicate there is an incoming announcement, during news broadcasts. When the audio unit interrupts for a news broadcast the preset volume level will be the same as traffic announcements.

Press the **MENU** button.

Action	Message
1	Audio settings
2	News

1. Turn on or off with the **OK** button.
2. Press the **MENU** button to return.

Alternative Frequencies

The majority of programs that broadcast on the FM frequency band have a program identification code, it can be recognized by audio units.

When your vehicle moves from one transmission area to another with the alternative frequencies tuning switched on, this function will search for the strongest station signal.

Under certain conditions, however, alternative frequencies tuning may temporarily disrupt normal reception.

When selected, the unit continually evaluates signal strength and, if a better signal becomes available, the unit will switch to that alternative. It mutes while it checks a list of alternative frequencies and if necessary, it will search once across the selected frequency band for a genuine alternative frequency.

It will restore radio reception when it finds one or if one is not found, the unit will return to the original stored frequency.

When selected, AF may appear in the display.

Press the **MENU** button.

Action	Message
1	Audio settings
2	Alt. frequency

1. Turn on or off with the **OK** button.
2. Press the **MENU** button to return.

Regional Mode

Regional mode controls the behavior of alternative frequencies switching between regionally related networks of a parent broadcaster. A broadcaster may run a fairly large network across a large part of the country. At various times of the day this large network may be broken down into a number of smaller regional networks, typically centered on major towns or cities. When the network is not split into regional variants, the whole network carries the same programming.

Audio System

Regional mode on: This prevents random alternative frequency switches when neighboring regional networks are not carrying the same programming.

Regional mode off: This allows a larger coverage area if neighboring regional networks are carrying the same programming, but can cause random alternative frequency switches if they are not.

Press the **MENU** button.

Action	Message
1	Audio settings
2	RDS regional

1. Turn on or off with the **OK** button.
2. Press the **MENU** button to return.

DIGITAL RADIO

The system allows you to listen to DAB (Digital Audio Broadcast) radio stations.

Note: Coverage differs from region to region and will influence the quality of reception. It is broadcast nationwide, regionally and locally.

The following formats are supported:

- DAB
- DAB+
- DMB-Audio (Digital Multimedia Broadcasting).

Ensembles

Ensembles contain a group of radio stations. Each ensemble can consist of several different radio stations.

The radio station name displays below the ensemble name.

Note: When you tune from one ensemble to another, it can take a while until the system synchronizes to the next ensemble. The system mutes during synchronization.

Selecting Radio Band

DAB1 and DAB2 operate in the same way. You can store up to 10 different presets on each band.

1. Press the **RADIO** button.
2. Press the left arrow button to display the available wavebands.
3. Select **DAB1** or **DAB2**.

Radio Station Tuning Control

Press the **RADIO** button and select **DAB1** or **DAB2**. Both preset banks operate in the same way and can store up to 10 different preset radio stations.

Note: When you reach the first or last radio station within an ensemble, further tuning will skip to the next ensemble. There may be a delay during this change and the audio will briefly mute.

Seek Tuning

1. Press a seek button. The system will stop at the first radio station it finds in the direction chosen.

Radio Station List

This feature displays all the available radio stations in a list.

1. Press function button 1.
2. Press the left or right arrow buttons to change ensembles. Press the up or down arrow button to navigate to your required radio station.
3. Press **OK** to confirm your selection.

Note: The display will only show radio stations in the current ensemble.

Audio System

Manual Tuning

1. Press function button 2.
2. Press the left or right arrow button to tune up or down the waveband in small increments. Press and hold to move through the waveband quickly.
3. Press **OK** to confirm your selection.

Note: *Seek tuning is also possible within this screen.*

Radio Station Preset Buttons

This feature allows you to store up to 10 favorite radio stations from any ensemble in each preset bank.

1. Select a radio station.
2. Press and hold one of the preset buttons. A progress bar and message will appear. When the progress bar completes the radio station has been stored. The system will mute momentarily as confirmation.

Once stored press a preset button at any time to select a favourite radio station.

Note: *Radio stations stored on the preset buttons may not always be available if you have left the coverage area. The system will mute when this happens.*

Radio Text

You can display extra information. For example; artist name. To switch this option on, select a radio station and press function button 3.

Note: *Extra information may not always be available.*

Service Linking

If you leave the coverage area of a DAB radio station the system will automatically switch to the corresponding FM radio station.

You can switch this feature on and off using the information display. See **General Information** (page 62).

Note: *If a DAB radio station has no corresponding FM radio station, the audio will mute when attempting to switch.*

Note: *The system will display the FM symbol when DAB and FM radio stations link.*

AUDIO INPUT JACK

WARNINGS



Driving while distracted can result in loss of vehicle control, accident and injury. We strongly recommend that you use extreme caution when using any device or feature that may take your focus off the road. Your primary responsibility is the safe operation of your vehicle. We recommend against the use of any handheld device while driving and encourage the use of voice-operated systems when possible. Make sure you are aware of all applicable local laws that may affect the use of electronic devices while driving.



For safety reasons, do not connect or adjust the settings on your portable music player while your vehicle is moving.



Store the portable music player in a secure location, such as the center console or the glove box, when your vehicle is in moving. Hard objects may become projectiles in a collision or sudden stop, which may increase the risk of serious injury. The audio extension cable must be long enough to allow the portable music player to be safely stored while your vehicle is moving.

Audio System

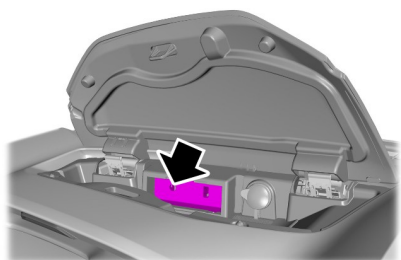

E169601

5. Switch the portable music player on and adjust its volume to half its maximum level.
6. Select the auxiliary input mode on the audio unit. You should hear music from your device even if it is low.
7. Adjust the volume on your portable music player until it reaches the volume level of the FM station or CD. Do this by switching back and forth between the AUX and FM or CD controls.

USB PORT

The auxiliary input jack allows you to connect and play music from your portable music player through your vehicle speakers. You can use any portable music player designed for use with headphones. Your audio extension cable must have male 1/8 inch (3.5mm) connector at each end.

1. Make sure your vehicle is stationary with the radio and portable music players turned off.
2. Plug the extension cable from the portable music player into the auxiliary input jack.
3. Switch the radio on. Select either a tuned FM station or a CD.
4. Adjust the volume as desired.

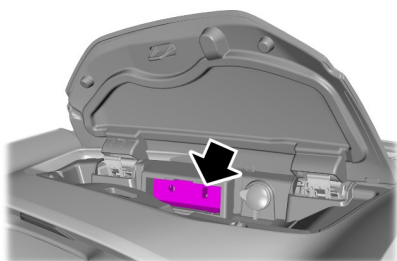

E169602

The USB port allows you to plug in media playing devices, memory sticks and charge devices (if supported). See **General Information** (page 235).

AUDIO TROUBLESHOOTING

Message	Description and Action
Please check CD	General error message for CD fault conditions. For example cannot read the CD, data-CD inserted, etc. Make sure the disc is loaded correctly. Clean and re-try, or replace disc with known music disc. If error persists contact an authorized dealer.
Drive malfunction	General error message for CD fault conditions. For example a mechanism fault.
drive too hot	Ambient temperature too hot – unit will not work until it has cooled down.

GENERAL INFORMATION

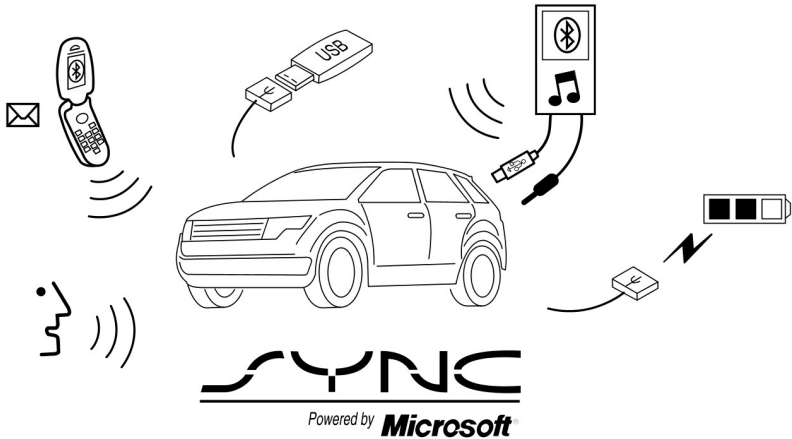

E142598

SYNC is an in-vehicle communications system that works with your Bluetooth-enabled cell phone and portable media player.

This allows you to:

- Make and receive calls
- Access and play music from your media player
- Use Emergency Assistance
- Access phonebook contacts and music using voice commands
- Stream music from your connected cell phone
- Select pre-defined text messages

- Use the advanced voice recognition system
- Charge your USB device (if your device supports this).

Make sure that you review your device's manual before using it with SYNC.

Support

For further support, see an authorized dealer. For more information, visit the regional Ford website.

Safety Information

WARNING



Driving while distracted can result in loss of vehicle control, crash and injury. We strongly recommend that you use extreme caution when using any device that may take your focus off the road. Your primary responsibility is the safe operation of your vehicle. We recommend against the use of any hand-held device while driving and encourage the use of voice-operated systems when possible. Make sure you are aware of all applicable local laws that may affect the use of electronic devices while driving.

When using SYNC:

- Do not operate playing devices if the power cords or cables are broken, split or damaged. Carefully place cords and cables where you cannot step on them or they do not interfere with the operation of pedals, seats, compartments or safe driving abilities.
- Do not leave playing devices in your vehicle during extreme conditions as it could cause them damage. Refer to your device's manual for further information.
- Do not attempt to service or repair the system. See an authorized dealer.

Privacy Information

When a cell phone is connected to SYNC, the system creates a profile that is linked to that cell phone. The system creates the profile to offer you more mobile features and to operate more efficiently. Among other things, this profile may contain data about your phonebook, text messages (read and unread) and call history. This will include the history of calls when your cell phone was not connected to the system. If you connect a media player, the system creates and retains an index of

supported media content. The system also records a short development log of approximately 10 minutes of all recent system activity. The log profile and other system data may be used to improve the system and help diagnose any problems that may occur.

The cell phone profile, media player index and development log will remain in the system unless deleted. They are generally accessible in your vehicle only when you connect your cell phone or media player. If you no longer plan to use the system or your vehicle, we recommend you complete a master reset to erase all stored information. See **Information Displays** (page 62).

Special equipment is required to access system data. Access to your vehicle's SYNC module is also required. We will not access the system data for any purpose other than as described without consent. Examples where system data can be accessed are for a court order, where required by law enforcement, other government authorities or other third parties acting with lawful authority. Other parties may seek to access the information independently of us. Further privacy information is available. See **SYNC™ Applications and Services** (page 250).

USING VOICE RECOGNITION

This system helps you control many features using voice commands. This allows you to keep your hands on the steering wheel and focus on what is around you.

Helpful Hints

Make sure the interior of your vehicle is as quiet as possible. Wind noise from open windows and road vibrations may prevent the system from correctly recognizing spoken commands.

Before giving a voice command, wait for the system announcement to finish followed by a single beep. Any command spoken before this does not register with the system.

Speak naturally, without long pauses between words.

You can interrupt the system at any time while it is speaking by pressing the voice button. You can also cancel a voice session at any time by pressing and holding the voice button.

Initiating a Voice Session



Press the voice button. A list of available commands appears in the display.

Command	Description
Bluetooth audio	Stream audio from your cell phone.
(cancel stop exit)	Cancel the requested action.
((line AV audio video) in AUX audio video)	Access the device connected to the auxiliary input jack.
(phone Blackberry iPhone Mobile)	Make calls.
(USB [stick] iPod MP3 [player])	Access the device connected to your USB port.
voice settings	Adjust the level of voice interaction and feedback.
[main menu] help	Hear a list of voice commands available in the current mode.

System Interaction and Feedback

The system provides feedback through audible tones, prompts, questions and spoken confirmations depending on the situation and your chosen level of interaction. You can customize the voice recognition system to provide more or less instruction and feedback.

The default setting is to a higher level of interaction in order to help you learn to use the system. You can change these settings at any time.

Adjusting the Interaction Level



Press the voice button. When prompted:

Command	Description
voice settings	Provides access to change the interaction level.

Then any of the following:

Command	Description
interaction mode advanced	Provides less audible interaction and more tone prompts.
interaction mode novice	Provides more detailed interaction and guidance.

Confirmation prompts are short questions the system asks when it is not sure of your request or when there is more than one possible response to your request. For example, the system may ask if the command phone is correct.

Press the voice button. When prompted:

Command	Description
voice settings	Provides access to change the confirmation prompt setting.

Then any of the following:

Command	Description
confirmation prompts off	Makes a best guess from the command. You may still occasionally be asked to confirm settings.
confirmation prompts on	Clarifies your voice command with a short question.

The system creates suggestion lists when it has the same confidence level of several options based on your voice commands. When switched on, the system may prompt you with as many as four possibilities for clarification.

Command	Description
media candidate lists off	Makes a best guess from the media suggestion list. The system may occasionally ask you questions.
media candidate lists on	Clarifies your voice command for media suggestions.
phone candidate lists off	Makes a best guess from the cell phone suggestion list. The system may occasionally ask you questions.
phone candidate lists on	Clarifies your voice command for cell phone suggestions.

Changing the Voice Settings

You can change the voice settings using

the information and entertainment display.

Press the **MENU** button.

Action	Message
1	SYNC-Settings
2	Voice settings

USING SYNC™ WITH YOUR PHONE

Hands-free calling is one of the main features of SYNC. While the system supports a variety of features, many are dependent on your cell phone's functionality.

At a minimum, most cell phones with Bluetooth wireless technology support the following functions:

- Answering an incoming call.
- Ending a call.
- Using privacy mode.
- Dialing a number.
- Redialing.
- Call waiting notification.
- Caller ID.

Other features such as text messaging using Bluetooth and automatic phonebook download are cell phone dependent features. To check your cell phone's compatibility, refer to your device's manual or visit the regional Ford website.

Pairing a Cell Phone For the First Time

Wirelessly pairing your cell phone with the system allows you to make and receive hands-free calls.

Note: *You must switch the ignition and radio on.*

Note: *To scroll through the menus, press the up or down arrows on your audio system.*

1. Make sure the Bluetooth feature on your cell phone is switched on before starting the search. Refer to your device's manual if necessary.
2. Press the **PHONE** button. When the audio display indicates that no phones are paired, select the option to add.
3. When a message to begin pairing appears in the audio display, search for SYNC on your cell phone to start the pairing process.
4. When prompted on your cell phone's display, enter the six-digit PIN provided by the system in the audio display. The display indicates when the pairing is successful.

Depending on your cell phone's capability and your market, the system may prompt you with questions such as setting the current cell phone as the primary cell phone (the cell phone the system automatically tries to connect with first when you switch the ignition on), downloading your phonebook, etc.

Pairing Subsequent Cell Phones

Wirelessly pairing your cell phone with the system allows you to make and receive hands-free calls.

Note: *You must switch the ignition and radio on.*

Note: *To scroll through the menus, press the up or down arrows on your audio system.*

1. Make sure the Bluetooth feature on your cell phone is switched on before starting the search. Refer to your device's manual if necessary.
2. Press the **PHONE** button.
3. Select the option for Bluetooth devices.
4. Press the **OK** button.
5. Select the option to add. This starts the pairing process.
6. When a message to begin pairing appears in the audio display, search for SYNC on your device to start the pairing process.
7. When prompted on your cell phone's display, enter the six-digit PIN provided by the system in the audio display. The display indicates when the pairing is successful.

The system may prompt you with questions such as setting the current cell phone as the primary cell phone, downloading your phonebook, etc.

Cell Phone Voice Commands



Press the voice button and when prompted say either:

Command	Action
call (someone [[a] name])	You do not need to say "phone" prior to these commands.
Call <name> at home	You do not need to say "phone" prior to these commands.
Call <name> at work	You do not need to say "phone" prior to these commands.
Call <name> in office	You do not need to say "phone" prior to these commands.
Call <name> on cell	You do not need to say "phone" prior to these commands.
Call <name> on other	You do not need to say "phone" prior to these commands.
Call history incoming	These commands are not available until your cell phone information has completely downloaded using Bluetooth.
Call history missed	These commands are not available until your cell phone information has completely downloaded using Bluetooth.
Call history outgoing	These commands are not available until your cell phone information has completely downloaded using Bluetooth.
[Phone] Connections	These commands are not available until your cell phone information has completely downloaded using Bluetooth.
dial [[a] number]	You do not need to say "phone" prior to these commands.
([go to] privacy [on] transfer to phone handsfree off)	
(hold call [on] (put place) call on hold)	

Command	Action
join (call calls)	
Menu	These commands are not available until your cell phone information has completely downloaded using Bluetooth. See Menu table.
Phonebook <name>	These commands are not available until your cell phone information has completely downloaded using Bluetooth.
Phonebook <name> at home	These commands are not available until your cell phone information has completely downloaded using Bluetooth.
Phonebook <name> in office	These commands are not available until your cell phone information has completely downloaded using Bluetooth.
Phonebook <name> at work	These commands are not available until your cell phone information has completely downloaded using Bluetooth.
Phonebook <name> on cell	These commands are not available until your cell phone information has completely downloaded using Bluetooth.
Phonebook <name> on other	These commands are not available until your cell phone information has completely downloaded using Bluetooth.

Phonebook Commands

Press the voice button and when prompted say either:

When you ask the system to access a phonebook name, number, etc., the requested information appears in the audio display.

Command	Action
call (someone [[a] name])	To call the contact.
dial [[a] number]	112 (one-one-two), 700 (seven hundred) etc.
Pound	
Number	0 (zero) to 9 (nine)
Asterisk	
clear	Deletes all entered digits
(delete correct)	Deletes one digit

Command	Action
Plus	
Star	

Note: To exit dial mode, press and hold the phone button or any button on the audio unit.

Menu Commands

Press the voice button and when prompted say either:

Command
[Phone] Connections
[Phone] [Message] Notification off
[Phone] [Message] Notification on
(turn ringer on silent mode off)
[Phone] [Set] Ringer 1
[Phone] [Set] Ringer 2
[Phone] [Set] Ringer 3
(turn ringer off silent mode [on])
Phone name
Text message inbox

Words in parenthesis are optional and do not have to be spoken for the system to understand the command.

Making a Call

Press the voice button and when prompted say either:

Command	Action
call (someone [[a] name])	
dial [[a] number]	Followed by a number. When the system confirms the number say: dial [[a] number]

To erase the last spoken digit say:

Command	Action
(delete correct)	Or press the left arrow button on the audio unit.

To erase all spoken digits say:

Command	Action
clear	Or press and hold the left arrow button on the audio unit.

To end the call, press the end call button on the steering wheel or select the end call option in the audio display and press **OK**.

Cell Phone Options During an Active Call

During an active call, you have extra menu features which become available, for example putting a call on hold.

To access this menu, choose one of the options available at the bottom of the audio display or select the option for more.

Receiving a Call

When receiving a call, you can:

- Answer the call by pressing the accept call button on the steering wheel or by selecting the accept call option in the audio display. Press the **OK** button.
- Reject the call by pressing the reject call button on the steering wheel or by selecting the reject call option in the audio display. Press the **OK** button.
- Ignore the call by doing nothing.

Message	Description and Action
Mic. off	Turn your vehicle's microphone off. To turn the microphone on, select the option again.
Privacy	Switch a call from an active hands-free environment to your cell phone for a more private conversation. When selected, the audio display will indicate the call is private.
Hold	Put an active call on hold. When selected, the audio display will indicate the call is on hold.
Dial a number	Enter numbers using the audio system numeric keypad, for example numbers for passwords.

Message	Description and Action
Join calls	<p>Join two separate calls. The system supports a maximum of three callers on a multi-party or conference call.</p> <ol style="list-style-type: none"> 1. Select the option for more. 2. Access the desired contact through the system or use voice commands to place the second call. Once actively in the second call, select the option for more. 3. Scroll to the option to join calls and press the OK button.
Phonebook	<p>Access your phonebook contacts.</p> <ol style="list-style-type: none"> 1. Select the option for more. 2. Scroll to the option for phonebook and press the OK button. 3. Scroll through your phonebook contacts. 4. Press the OK button again when the desired selection appears in the audio display. 5. Press the OK button or dial button to call the selection.
Call history	<p>Access your call history log.</p> <ol style="list-style-type: none"> 1. Select the option for more. 2. Scroll to the option for call history appears and press the OK button. 3. Scroll through your call history options (incoming, outgoing or missed). 4. Press the OK button again when the desired selection appears in the audio display. 5. Press the OK button or dial button to call the selection.

Accessing Features Through the Cell Phone Menu

You can access your call history, phonebook, sent text messages as well as access cell phone and system settings. You can also access advanced features such as emergency assistance.

The system attempts to automatically re-download your phonebook and call history each time your cell phone connects to the system. You must turn on the auto download feature if your cell phone supports it.

Note: *This is a cell phone dependent feature.*

1. Press the **PHONE** button to enter the cell phone menu.
2. Select one of the options available.

Message	Description and Action
Dial a number	Dial a number using the audio system numeric keypad.
Redial	Redial the last number called (if available). Press the OK button to select.
Phonebook	<p>Access your downloaded phonebook.</p> <ol style="list-style-type: none"> 1. Press the OK button to confirm and enter. You can use the options at the bottom of the screen to quickly access an alphabetical category. You can also use the letters on the keypad to jump in the list. 2. Scroll through your phonebook contacts. 3. Press the OK button again when the desired selection appears in the audio display. 4. Press the OK button or dial button to call the selection.
Call history	<p>Access any previously dialed, received or missed calls.</p> <ol style="list-style-type: none"> 1. Press the OK button to select. 2. Scroll to select either incoming calls, outgoing calls or missed calls. Press the OK button to make your selection. 3. Press the OK button or dial button to call the selection.
Speed Dial	Select one of 10 speed dial entries. To set a speed dial entry, go to the phonebook and press and hold one of the numbers on the audio system numeric keypad.
Text messaging	Send, download and delete text messages.
BT Devices	Access the option for Bluetooth device menu listings (add, connect, set as primary, on or off, delete).
Phone settings	View various settings and features on your cell phone.
Emergency Assistance	Turn the SYNC emergency assistance feature on or off.

Text Messaging

The system allows you to receive, send, download and delete text messages. The system can also read incoming text messages to you so that you do not have to take your eyes off the road.

Note: *This is a cell phone dependent feature.*

Receiving a Text Message

When a new message arrives, an audible tone sounds and the audio display indicates you have a new message.

You have these options:

- Select the listen option to have the system read the message to you.
- Select the view option to open the text message. Select the ignore option or do nothing and the message goes into your text message inbox. Once selected, you have the ability to have the message read out to you, to view other messages or to select the more option.

- Press the voice button and say "Read text message".
- Select the more option and use the arrow buttons to scroll through further options.

Note: *Your cell phone must support downloading text messages using Bluetooth to receive incoming text messages.*

Choose from the following:

Message	Action
Reply to sender	Press the OK button to access and then scroll through the list of pre-defined messages to send.
Call sender	Press the OK button to call the sender of the message.
Forward msg.	Press the OK button to forward the message to anyone in your phonebook or call history. You can also choose to enter a number.

Sending, Downloading and Deleting Your Text Messages

1. Press the **PHONE** button.

2. Select the text messaging option, then press the **OK** button.

Choose from the following:

Message	Description and Action
New	When you select the option to send a text message, a list of pre-defined messages appear in the audio display. Allows you to send a new text message based on a pre-defined set of 15 messages.
View	Allows you to read the full message and in addition provides the option to have the message read out to you by the system. To go to the next message select the more option. This allows you to reply to the sender, call the sender or forward the message.
Delete	Allows you to delete current text messages from the system (not your cell phone). The audio display indicates when all your text messages have been deleted.
More...	Allows you to delete all messages or to manually trigger a download of all unread messages from your cell phone.

Sending a Text Message

1. Select the send option when the desired selection is highlighted in the audio display.
2. Select the confirmation option when the contact appears and press the **OK** button again to confirm when the system asks if you would like to send the message. Each text message is sent with a pre-defined signature.

Note: You can send text messages either by choosing a contact from the phonebook and selecting the text option from the audio display or by replying to a received message in the inbox.

Note: Only one recipient is allowed per text message.

Accessing Your Cell Phone Settings

These are cell phone dependent features. Your cell phone settings allow you to access and adjust features such as your ringtone, text message notification, modify your phonebook and set up automatic download.

1. Press the **PHONE** button.
2. Scroll until the phone settings option appears, then press the **OK** button.
3. Scroll to select from the following options:

Message	Description and Action
Set as master	If this option is checked, the system will use this cell phone as the master when there is more than one cell phone paired to the system. This option can be changed for all paired cell phones (not only for the active one) using the Bluetooth devices menu.
Phone status	See the cell phone name, provider name, cell phone number, signal level and battery level. When done, press the left arrow button to return to the cell phone status menu.
Set ringtone	Select which ringtone sounds during an incoming call (one of the system's or your cell phone's). If your cell phone supports in-band ringing, your cell phone's ringtone sounds when you choose the cell phone ringtone option. <ol style="list-style-type: none"> 1. Press the OK button to select and scroll to hear each ringtone. 2. Press the OK button to select.
Text msg notify	Have the option of hearing an audible tone to notify you when a text message arrives. Press the OK button to turn the audible tone on or off.
Phonebook pref.	Modify the contents of your phonebook, e.g. add, delete, download. Press the OK button to select and scroll between:

Choose from the following:

Message	Description and Action
Add contacts	Push the desired contacts on your cell phone. Refer to your device's manual on how to push contacts. Press the OK button to add more contacts from your phonebook.
Delete	When a message asking you to delete appears, select the option to confirm. Press the OK button to delete the current phonebook and call history. The system takes you back to the menu for phone settings.
Download now	Press the OK button to select and download your phonebook to the system.
Auto-download	When automatic download is switched on, any changes, additions or deletions saved in the system since your last download are deleted. When automatic download is switched off, your phonebook will not be downloaded when your cell phone connects to the system. Your phonebook, call history and text messages can only be accessed when your paired cell phone is connected to the system. Check or uncheck this option to automatically download your phonebook each time your cell phone connects to the system. Downloading times are cell phone dependent and quantity dependent.

Bluetooth Devices

This menu provides access to your Bluetooth devices. Use the arrow buttons to scroll through the menu options. It allows you to add, connect and delete devices and set a cell phone as primary.

Bluetooth Devices Menu Options

1. Press the **PHONE** button.
2. Scroll until the Bluetooth device option appears, then press the **OK** button.
3. Scroll to select from the following options:

Message	Description and Action
Add	Pair additional cell phones to the system. <ol style="list-style-type: none"> 1. Select the option to add to start the pairing process. 2. When a message to begin pairing appears in the audio display, search for SYNC on your cell phone. Refer to your device's manual if necessary.

SYNC™

Message	Description and Action
	<ol style="list-style-type: none">3. When prompted on your cell phone's display, enter the six-digit PIN provided by the system in the audio display. The display indicates when the pairing is successful.4. When the option to set the cell phone as the primary cell phone appears, select either yes or no.5. Depending on the functionality of your cell phone, you may be asked extra questions (for example, if you would like to download your phonebook). Select either yes or no to confirm your response.
Delete	After deleting a cell phone from the list, the cell phone can only be connected again by repeating the full pairing process. Select the delete option and confirm when the system asks to delete the selected device.
Master	The system attempts to connect with the primary cell phone every time you switch the ignition on. When a cell phone is selected as primary, it appears first in the list and is marked with an asterisk. Set a previously paired cell phone as your primary cell phone. Select the master option to confirm the primary cell phone.
Conn.	Connect a previously paired cell phone. You can only have one cell phone connected at a time to use the cell phone functionality. When another cell phone is connected, the previous cell phone will be disconnected from the telephone services. The system allows you to use different Bluetooth devices for the cell phone functionality and the Bluetooth audio music playback feature at the same time.
Discon.	Disconnects the selected cell phone. Select this option and confirm when asked to. After disconnecting a cell phone, it can be connected again without repeating the full pairing process.

System Settings

1. Press the **MENU** button.
2. Select the SYNC settings option, then press the **OK** button.
3. Scroll to select from the following options:

Message	Description and Action
Bluetooth on	Check or uncheck this option to turn the Bluetooth interface of the system on or off. Select this option then press the OK button to change the option's status.
Set defaults	This selection does not erase your indexed information (phonebook, call history, text messages and paired devices). Select this option and confirm when prompted in the audio display. Return to the factory default settings.
Master reset	Completely erase all information stored on the system (phonebook, call history, text messages and paired devices) and return to the factory default settings. Select this option and confirm when prompted in the audio display. The display indicates when complete and the system takes you back to the previous menu.
Install on SYNC	Install applications or software updates you have downloaded. Select this option and confirm when prompted in the audio display. There must be a valid SYNC application or update available on the USB thumb drive in order to finish an installation successfully.
System info	Display the system's version numbers as well as its serial number. Press the OK button to select.
Voice settings	The voice settings submenu contains various options. See Using Voice Recognition (page 236).
Browse USB	Browse the actual menu structure of the connected USB device. Press the OK button and use the up or down arrows to scroll through the folders and files. Use the left or right arrows to enter and leave a folder. Media content can be directly selected for playback from this menu.
Emergency Assistance	You can turn the emergency assistance feature on or off. See SYNC™ Applications and Services (page 250).

SYNC™ APPLICATIONS AND SERVICES

A list of available applications appears. Each application may have its own specific settings.

Press the **MENU** button to enter the system menu.

Note: Some versions of SYNC may operate differently. Press the **PHONE** button instead of the **MENU** button to access the *Emergency Assistance* menu.

Message	Description and Action
SYNC-Apps	Scroll to this option, and then press OK .

SYNC Emergency Assistance

WARNINGS



For this feature to work, your cell phone must have Bluetooth and be compatible with the system.



Always place your cell phone in a secure location inside your vehicle. Failure to do so may cause serious injury to someone or damage the cell phone which could prevent this feature from working correctly.



Unless the feature setting is switched on prior to a crash, the system will not attempt to place an emergency call which could delay the response time, potentially increasing the risk of serious injury or death. Do not wait for the system to make an emergency call if you can do it yourself. Dial emergency services immediately to avoid a delayed response time. If you do not hear Emergency Assistance within five seconds of the crash, the system or cell phone may be damaged or non-functional.

If a crash deploys an airbag or triggers the fuel pump shut off, the system may contact emergency services by dialing 112 (the wireless emergency number that works in most European countries) through a paired and connected cell phone. For more information about the system and Emergency Assistance, visit the regional Ford website.

Note: Before selecting this feature, you must read the Emergency Assistance privacy notice later in this section for important information.

Note: When you switch this feature on or off, that setting applies for all paired cell phones. If you have turned this feature off and a previously paired phone connects when you switch on the ignition, either a voice message plays, a display message or icon is shown or both.

Note: Every cell phone operates differently. While this feature works with most cell phones, some cell phones may experience difficulties using this feature.

Note: Make sure you are familiar with the information about airbag deployment. See **Supplementary Restraints System** (page 27).

Switching Emergency Assistance On and Off

Press the **MENU** button then select:

Message	Action
SYNC-Apps	Press OK .
Emergency Assistance	Press OK . Select the option you require and press OK .

Display Options

If you switch on this feature, a confirmation message appears in the display.

If you switch off this feature, a dialog will appear in the display, which allows you to set a voice reminder.

Off with voice reminder provides a display and voice reminder when your cell phone connects and your vehicle starts.

Off without voice reminder provides a display reminder only without a voice reminder when your cell phone connects.

To make sure that Emergency Assistance works correctly:

- The system must have power and be working correctly at the time of the crash and during feature activation and use.
- You must switch on the feature before a crash.
- You must have a cell phone connected to the system.
- In certain countries, it may be necessary to have a valid and registered SIM card with credit in order to place and maintain an emergency call.
- A connected cell phone must have the ability to make and maintain an outgoing call at the time of the crash.
- A connected cell phone must have adequate network coverage, battery power and signal strength.
- Your vehicle must have battery power.

Note: *This feature only works in a European country or region where SYNC Emergency Assistance can call the local emergency services. Visit the regional Ford website for details.*

In the Event of a Crash

Note: *Not every crash deploys an airbag or triggers the fuel pump shut off (which may turn on Emergency Assistance). However, if Emergency Assistance is triggered the system tries to contact the emergency services. If a connected cell phone sustains damage or loses connection to the system, it searches for and tries to connect to any available previously paired cell phone. The system attempts to dial 112.*

Before making a call:

- If you do not cancel the call and SYNC makes a successful call, an introductory message plays for the emergency operator. After this message, there is hands-free communication between your vehicle's occupants and the operator.
- The system provides a short window of time (approximately 10 seconds) to cancel the call. If you do not cancel the call, the system attempts to dial 112.
- The system plays a message letting you know when it attempts to make an emergency call. You can cancel the call by selecting the relevant function button or by pressing the end call button on the steering wheel.

During a call:

- Emergency Assistance uses your vehicle GPS or cellular network information when available to determine the most appropriate language to use. It alerts the emergency operator of the crash and delivers the introductory message. This may include your vehicle GPS coordinates.
- The language the system uses to interact with the occupants of your vehicle may differ from the language used to deliver information to the emergency operator.

- After the delivery of the introductory message the voice line opens so that you can speak hands-free with the emergency operator.
- When the line is connected, you must be prepared to provide your name, phone number and location information immediately.

Note: *While the system provides information to the emergency operator, the system plays a message letting you know it is sending important information. It then lets you know when the line is open to start hands-free communication.*

Note: *During an Emergency Assistance call, an emergency priority screen appears which contains vehicle GPS coordinates when available.*

Note: *It is possible that GPS location information is not available at the time of the crash; in this case, Emergency Assistance will still attempt to place an emergency call.*

Note: *It is possible that the emergency services will not receive the GPS coordinates; in this case, hands-free communication with an emergency operator is available.*

Note: *The emergency operator may also receive information from the cellular network such as cell phone number, cell phone location and cell phone carrier name independent from SYNC Emergency Assistance.*

Emergency Assistance may not work if:

- Your cell phone or Emergency Assistance hardware sustains damage in the crash.
- The vehicle battery or the system has no power.
- A crash ejects your cell phone from your vehicle.

- You do not have a valid and registered SIM card with credit in your cell phone.
- You are in a European country or region where the SYNC Emergency Assistance cannot place the call. Visit the regional Ford website for details.

Important Information about the Emergency Assistance Feature

Emergency Assistance does not currently call emergency services in the following markets: Albania, Belarus, Bosnia and Herzegovina, Macedonia, Netherlands, Ukraine, Moldova and Russia.

Visit the regional Ford website for latest details.

Emergency Assistance Privacy Notice

When you switch on Emergency Assistance, it may disclose to emergency services that your vehicle has been in a crash involving the deployment of an airbag or activation of the fuel pump shut off. This feature has the capability to disclose your location information to the emergency operator or other details about your vehicle or crash to provide the most appropriate emergency services.

If you do not want to disclose this information, do not switch on the feature.

SYNC AppLink

The system enables voice and manual control of SYNC AppLink enabled smartphone apps. Once an app is running through AppLink, you can control main features of the app through voice commands and manual controls.

Note: *You must pair and connect your smartphone to SYNC to access AppLink.*

Note: *iPhone users need to connect the phone to the USB port.*

Note: *Android users need to connect the phone to SYNC using Bluetooth.*

Note: For information on available apps, supported smartphone devices and troubleshooting tips please visit the Ford website.

Note: Make sure you have an active account for the app that you have downloaded. Some apps will work automatically with no setup. Other apps will want you to configure your personal settings and personalize your experience by creating stations or favorites. We recommend you do this at home or outside of your vehicle.

To Access Using the SYNC Menu

Scroll through the list of available applications and press **OK** to select an app. Once an app is running through SYNC, press the right arrow button to access the app menu. You can access various app features from here, for example thumbs up and thumbs down. Press the left arrow button to exit the app menu.

Press the **MENU** button then select:

Message	Description and Action
SYNC-Apps	
Mobile Apps	Scroll to this option, and then press OK .
Find new Apps	Select this option if the app required is not listed.

Note: If a SYNC AppLink compatible app cannot be found, make sure the required app is running on the mobile device.

To Access Using Voice Commands

Press the voice button and when prompted say:

Command	Description and Action
mobile (apps applications)	Say the name of the application after the tone. The application will start. While an app is running through SYNC, you can press the voice button and speak commands specific to the app.

The following voice commands are always available:

Command	Description and Action
[main menu] help	Use this command to hear a list of available voice commands.
mobile (apps applications)	The system will prompt you to say the name of the app to start it.
list [mobile] (apps applications)	The system will list all of the currently available mobile apps.

Command	Description and Action
find [new] [mobile] (apps applications)	The system will search your connected mobile device for SYNC compatible apps.
<the name of the app>	Say the name of an app to start it on SYNC.
<the name of the app> Help	The system will list the available voice commands for the requested app.

Enabling and Disabling Push Notifications

Some apps can send push notifications. A push notification is an alert from an app running in the background and is delivered by voice, pop up or both. This may be particularly useful for news or location based apps.

Press the **MENU** button then select:

Message	Description and Action
SYNC-Apps	
Mobile Apps	
Settings	
All Apps	If push notifications are supported this setting will be listed. Select to enable or disable the feature as required.

Enabling SYNC Mobile Apps

To use the system you must consent to send and receive app authorization information and updates, using the data plan associated with the connected device.

Data is sent to Ford in the United States through the connected device. The information is encrypted and includes your VIN, SYNC module number, anonymous usage statistics and debugging information. Updates may take place automatically.

Note: You must enable mobile apps for each connected device the first time you select a mobile app using the system.

Note: Standard data rates will apply. Ford is not responsible for any additional charges you may receive from your service provider, when your vehicle sends or receives data through the connected device. This includes any additional charges incurred due to driving in areas when roaming out of a home network.

App Status

You can view the current status of an app in the settings menu. There are three possible statuses:

Message	Description and Action
Update needed	The system has detected a new app requiring authorization or a general permissions update is required.
Up-to-date	No update is required.
Updating...	The system is trying to receive an update.

Options in the settings menu:

Message	Description and Action
Request Update	If an update is required and you want to manually request the update, for example when you are in a Wi-Fi hotspot.
Disable Updates	Select this option to disable automatic updates.

App Permissions

Permissions are divided by groups. You can grant these group permissions individually. You can change a permission group status any time when not driving, by using the settings menu.

When you launch an app using SYNC, the system may ask you to grant certain permissions, for example:

- To allow your vehicle to provide vehicle information to the app including, but not limited to: Fuel level, fuel consumption, engine speed, battery voltage, odometer, VIN, external temperature, gear position, tire pressure, ambient temperature, date and time.
- To allow your vehicle to provide driving characteristic information, including, but not limited to: MyKey, seat belt status, engine speeds, braking events, brake pedal switch, acceleration, accelerator pedal position, clutch pedal switch, trip length, trip time, trip cost, percent engine on time, and percent of time at speed.

- To allow your vehicle to provide location information, including: GPS and speed.
- To allow the app to send push notifications using the vehicle display and voice capabilities while running in a background state.

Note: *You will only need to grant permissions the first time you use an app with SYNC.*

Note: *We are not responsible or liable for any damages or loss of privacy relating to usage of an app, or dissemination of any vehicle data that you approve us to provide to an app.*

USING SYNC™ WITH YOUR MEDIA PLAYER

You can access and play music from your media player through your vehicle's speaker system using the system's media menu or voice commands. You can also sort and play your music by specific categories such as artist or albums.

SYNC is capable of hosting nearly any media player including: iPod, Zune, Plays from device players, and most USB drives. SYNC also supports audio formats such as MP3, WMA, WAV and ACC.

Connecting Your Media Player to the USB Port

Note: *If your media player has a power switch, make sure you switch on the device.*

To Connect Using Voice Commands

1. Plug the device into your vehicle's USB port.
2. Press the voice button and when prompted say:

Command	Description and Action
(USB [stick] iPod MP3 [player])	You can now play music by saying any of the appropriate voice commands. Refer to the media voice commands.

To Connect Using the System Menu

1. Plug the device into your vehicle's USB port.

2. Press the **AUX** button until an initializing message appears in the display.

Message	Description and Action
Browse USB	Depending on how many media files are on your connected device, an indexing message may appear in the display. When indexing is complete, the screen returns to the playback menu.

Choose from the following:

Message
Play all
Playlists
Songs
Artists
Albums
Genres
Browse USB
Reset USB
Exit

What's Playing?

At any time during playback, you can press the voice button and ask the system what is playing. The system reads the metadata tags (if populated) of the current track.

Media Voice Commands



Press the voice button and when prompted say:

Command	Description and Action
(USB [stick] iPod MP3 [player])	You can now play music by saying any of the appropriate voice commands.

Then any of the following:

Command	Description and Action
play	
pause	
Play album <name>	<name> is a dynamic listing, meaning that it could be the name of anything such as desired group, artist or song. Voice commands that are not available until indexing is complete.
play all	
play [artist]	<name> is a dynamic listing, meaning that it could be the name of anything such as desired group, artist or song. Voice commands that are not available until indexing is complete.
play [genre]	<name> is a dynamic listing, meaning that it could be the name of anything such as desired group, artist or song. Voice commands that are not available until indexing is complete.
[Play] Next folder	Voice commands that are only available in folder mode.
[Play] Next track	
play [playlist]	<name> is a dynamic listing, meaning that it could be the name of anything such as desired group, artist or song. Voice commands that are not available until indexing is complete.
[Play] Previous folder	Voice commands that are only available in folder mode.
[Play] Previous track	
Play song <name>	<name> is a dynamic listing, meaning that it could be the name of anything such as desired group, artist or song.

SYNC™

Command	Description and Action
Play track <name>	<name> is a dynamic listing, meaning that it could be the name of anything such as desired group, artist or song. Voice commands that are not available until indexing is complete.
repeat [all folder track song] off	
repeat (track song) [on]	
Search album <name>	<name> is a dynamic listing, meaning that it could be the name of anything such as desired group, artist or song. Voice commands that are not available until indexing is complete.
Search artist <name>	<name> is a dynamic listing, meaning that it could be the name of anything such as desired group, artist or song. Voice commands that are not available until indexing is complete.
Search genre <name>	<name> is a dynamic listing, meaning that it could be the name of anything such as desired group, artist or song.
Search song <name>	<name> is a dynamic listing, meaning that it could be the name of anything such as desired group, artist or song.
Search track <name>	<name> is a dynamic listing, meaning that it could be the name of anything such as desired group, artist or song. Voice commands that are not available until indexing is complete.
(shuffle random mix) [disc CD [player] folder] off	
(shuffle random mix) [on (tracks songs) [on]]	
[play] (similar music more like this)	
((who's who is) this who plays this (what's what is) playing [now] (what which) (song track artist) is this (who's who is) playing (what's what is) this)	

Voice Command Guide

Command	Description and Action
Search genre	The system searches all the data from your indexed music and if available, begins to play the chosen type of music.
play [genre]	You can only play genres of music that are present in the genre metadata tags that you have on your media player.
[play] (similar music more like this)	The system compiles a playlist and then plays similar music to what is currently playing from the USB port using indexed metadata information.
Search artist	The system searches for a specific artist, track or album from the music indexed through the USB port.
Search track	The system searches for a specific artist, track or album from the music indexed through the USB port.
Search album	The system searches for a specific artist, track or album from the music indexed through the USB port.
play [artist]	The system searches for a specific artist, track or album from the music indexed through the USB port.
Play track	The system searches for a specific artist, track or album from the music indexed through the USB port.
Play album	The system searches for a specific artist, track or album from the music indexed through the USB port.

The system is also capable of playing music from your cell phone through Bluetooth.

To switch the Bluetooth audio on, use the **AUX** or **Source** button or press the voice button and when prompted and say:

Command	Description and Action
Bluetooth audio	

Then any of the following:

Command	Description and Action
[Bluetooth] Connections	
pause	
play	
[Play] Next track	
[Play] Previous track	

Press **AUX** to select USB playback.

Media Menu Features

The media menu allows you to select how to play your music (such as by artist, genre, shuffle or repeat) and to find similar music or reset the index of your USB devices.

Message	Description and Action
Options	This will enter the media menu.

Then any of the following:

Message	Description and Action
Shuffle	Choose to shuffle or repeat your music. Once you make your choice, it remains on until you switch it off.
Repeat track	Choose to shuffle or repeat your music. Once you make your choice, it remains on until you switch it off.
Similar music	You can play similar types of music to the current playlist from the USB port. The system uses the metadata information of each track to compile a playlist. The system then creates a new list of similar tracks and then begins playing. Each track must have the metadata tags populated for this feature. With certain playing devices, if your metadata tags

Message	Description and Action
	are not populated, the tracks will not be available in voice recognition, the play menu or this option. However, if you place these tracks onto your playing device in mass storage device mode they are available in voice recognition, the play menu or this option. The system places unknowns into any unpopulated metadata tag.
Reset SYNC USB	Resets the USB index. After the new indexing is complete you can choose what to play from the USB song library.

Accessing Your USB Song Library

1. Plug the device into your vehicle's USB port.

2. Press **AUX** to select USB playback.

Message	Description and Action
Browse USB	This menu allows you to select and play your media files by artist, album, genre, playlist and track or even to browse what is on your USB device.

If there are no media files to access, the display indicates there is no media. If there are media files, you have the following options to scroll through and select:

Message	Description and Action
Play all	Play all indexed media files from your playing device one at a time in numerical order.* 1. Press OK to select. The first track title appears in the display.
Playlists	Access your playlists (from formats such as ASX, M3U, WPL or MTP).* 1. Press OK to select. 2. Scroll to select the desired playlist, and then press OK .
Songs	Search for and play a specific indexed track.* 1. Press OK to select. 2. Scroll to select the desired track, and then press OK .

SYNC™

Message	Description and Action
Artists	Sort all indexed media files by artist. Once selected, the system lists and then plays all artists and tracks alphabetically.* 1. Press OK to select. 2. Scroll to select the desired artist, and then press OK .
Albums	Sort all indexed media files by albums.* 1. Press OK to select. 2. Scroll to select the desired albums, and then press OK .
Genres	Sort indexed music by genre (category) type.* 1. Press OK to select. 2. Scroll to select the desired genre, and then press OK .
Browse USB	Browse all supported media files on your media player connected to the USB port. You can only view media files that are compatible with SYNC; other saved files are not visible. 1. Press OK to select. 2. Scroll to browse indexed media files on your flash drive, and then press OK .
Reset USB	Resets the USB index. After the new indexing is complete, you can choose what to play from the USB song library.

* You can use the buttons at the bottom of the audio display to jump to a certain alphabetical category quickly. You can also use the letters on the numeric keypad to jump in the list.

Bluetooth Devices and System Settings

You can access these menus using the audio display. See **Using SYNC™ With Your Phone** (page 239).

SYNC™ TROUBLESHOOTING

Your SYNC system is easy to use. However, should questions arise, please refer to the tables below.

To check your cell phone's compatibility, visit the regional Ford website.

SYNC™

Cell phone issues		
Issue	Possible cause	Possible solution
A lot of back-ground noise during a phone call.	The audio control settings on your cell phone may be affecting SYNC performance.	Refer to your device's manual about audio adjustments.
During a call, I can hear the other person but they cannot hear me.	Possible cell phone malfunction.	Try switching off your cell phone, resetting it or removing the battery, then trying again. Make sure that the microphone for SYNC is not set to off.
SYNC is not able to download my phonebook.	This is a cell phone-dependent feature.	Check your cell phone's compatibility.
	Possible cell phone malfunction.	Try switching off your cell phone, resetting it or removing the battery, then trying again.
		Try pushing your phonebook contacts to SYNC by selecting the option to add.
		You must switch on your cell phone and the automatic phonebook download feature on SYNC.
The system says "Phonebook downloaded" but my SYNC phonebook is empty or is missing contacts.	Limitations on your cell phone's capability.	Try pushing your phonebook contacts to SYNC by selecting the option to add.
		If the missing contacts are stored on your SIM card, try moving them to your cell phone's memory.
		Remove any pictures or special ring tones associated with the missing contact.
		You must switch on your cell phone and the automatic phonebook download feature on SYNC.
I am having trouble connecting my cell phone to SYNC.	This is a cell phone-dependent feature.	Check your cell phone's compatibility.
	Possible cell phone malfunction.	Try switching off your cell phone, resetting it or removing the battery, then trying again.

Cell phone issues		
Issue	Possible cause	Possible solution
		Try deleting your device from SYNC and deleting SYNC from your device, then trying again.
		Always check the security and auto accept prompt settings relative to the SYNC Bluetooth connection on your cell phone.
		Update your cell phone's firmware.
		Switch off the auto download setting.
Text messaging is not working on SYNC.	This is a cell phone-dependent feature.	Check your cell phone's compatibility.
	Possible cell phone malfunction.	Try switching off your cell phone, resetting it or removing the battery, then trying again.
Audible text messages do not work on my cell phone.	This is a cell phone-dependent feature.	Your cell phone must support downloading text messages through Bluetooth to receive incoming text messages.
		Access the text messaging menu of SYNC to see if your cell phone supports the feature. Press the PHONE button and then scroll and select the option for text messaging, then press OK .
	This is a cell phone limitation.	Because each cell phone is different, refer to your device's manual for the specific cell phone you are pairing. In fact, there can be differences between cell phones due to brand, model, service provider and software version.

USB and media issues		
Issue	Possible cause	Possible solution
I am having trouble connecting my device.	Possible device malfunction.	Try switching off the device, resetting it or removing the battery, then trying again.
		Make sure you are using the manufacturer's cable.
		Make sure correctly insert the USB cable to the device and your vehicle's USB port.
		Make sure that the device does not have an auto-install program or active security settings.
SYNC does not recognize my device when I start my vehicle.	This is a device limitation.	Make sure you are not leaving the device in your vehicle during very hot or cold temperatures.
Bluetooth audio does not stream.	This is a device-dependent feature.	Make sure you connect the device to SYNC and press play on your device.
	The device is not connected.	
SYNC does not recognize music that is on my device.	Your music files may not contain the correct artist, song title, album or genre information.	Make sure that all song details are populated.
	The file may be corrupted.	Try replacing the corrupt file with a new version.
	The song may have copyright protection that does not allow it to play.	Some devices require you to change the USB settings from mass storage to media transfer protocol class.
When I connect my iPhone or iPod Touch through the USB and Bluetooth Audio at the same time, I sometimes do not hear any sound.	This is a device limitation.	From the iPhone or iPod Touch music now playing screen, select the audio device airplay icon at the very bottom of your iPhone or iPod Touch screen.
		To listen to the iPhone or iPod Touch through Bluetooth Audio, select SYNC.
		To listen to the iPhone or iPod Touch through USB, select Dock Connector.

Voice command issues		
Issue	Possible cause	Possible solution
SYNC does not understand what I am saying.	You may be using the wrong voice commands.	Review the cell phone voice commands and the media voice commands at the beginning of their respective sections.
		Refer to the audio display during an active voice session to find a list of voice commands there.
	You may be speaking too soon or at the wrong time.	The microphone for the system is either in your rear view mirror or in the headliner just above the windshield.
SYNC does not understand the name of a song or artist.	You may be using the wrong voice commands.	Review the media voice commands at the beginning of the media section.
	You may not be saying the name exactly as the system saved it.	Say the song or artist exactly as the system saved it. If you say, "Play Artist Prince", the system does not play music by Prince and the Revolution or Prince and the New Power Generation.
		Make sure you are saying the complete title such as "California remix featuring Jennifer Nettles".
		If the song titles are in capital letters, you have to spell them. LOLA requires you to say "L-O-L-A".
	The system may not be reading the name the same way you are saying it.	Do not use special characters in the title, as the system does not recognize them.
SYNC does not understand or is calling the wrong contact when I want to make a call.	You may be using the wrong voice commands.	Review the cell phone voice commands at the beginning of the cell phone section.
		You can also use the cell phone and media suggestion lists to get a list of possible suggestions when the system cannot fully understand you. See Using Voice Recognition (page 236).

Voice command issues		
Issue	Possible cause	Possible solution
	You may not be saying the name exactly as the system saved it.	Make sure you are saying the name exactly as the system saved it. For example, if the contact name is Joe Wilson, say "Call Joe Wilson".
		The system works better if you list full names such as "Joe Wilson" rather than "Joe".
	Contacts in your phonebook may be very short and similar or they may contain special characters.	Do not use special characters such as 123 or ICE as the system does not recognize them.
	Your phonebook contacts may be in capital letters.	If the contacts are in capital letters, you have to spell them. JAKE requires you to say "Call J-A-K-E".
The SYNC voice control system is having trouble recognizing foreign names stored on my cell phone.	You may be saying the foreign names using the currently selected language for SYNC.	SYNC applies the phonetic pronunciation rules of the selected language to the contact names stored on your cell phone.
		Helpful Hint: You can select your contact manually. Press PHONE . Select the option for phonebook and then contact name. Press the soft-key option to hear it. SYNC will read the contact name to you, giving you some idea of the pronunciation it is expecting.
The SYNC voice control system is having trouble recognizing foreign tracks, artists, albums, genres and playlist names from my media player or USB flash drive.	You may be saying the foreign names using the currently selected language for SYNC.	SYNC applies the phonetic pronunciation rules of the selected language to the names stored on your media player or USB flash drive. It is able to make some exceptions for very popular artist names (for example, U2) such that you can always use the English pronunciation for these artists.

SYNC™

Voice command issues		
Issue	Possible cause	Possible solution
The system generates voice prompts and the pronunciation of some words may not be accurate for my language.	SYNC uses text-to-speech voice prompt technology.	SYNC uses a synthetically generated voice rather than pre-recorded human voice.
		SYNC offers several new voice control features for a wide range of languages. Dialing a contact name directly from the phonebook without pre-recording (for example, "call John Smith") or selecting a track, artist, album, genre or playlist directly from your media player (for example, "play artist Madonna).
My previous Bluetooth voice control system allowed me to control the radio, CD, and climate control systems. Why can I not control these systems with SYNC?	The focus of SYNC is to control your mobile devices and the content stored on them.	SYNC offers significant capability beyond the previous system such as dialing a contact name directly from the phonebook without pre-recording (for example, "call John Smith") or selecting a track, artist, album, genre or playlist directly from your media player (for example, "play artist Madonna).

General		
Issue	Possible cause	Possible solution
<p>The language selected for the instrument cluster and information and entertainment display does not match the SYNC language (phone, USB, Bluetooth audio, voice control and voice prompts).</p>	<p>SYNC does not support the currently selected language for the instrument cluster and information and entertainment display.</p>	<p>SYNC only supports four languages in a single module for text display, voice control and voice prompts. The country where you bought your vehicle dictates the four languages based on the most popular languages spoken. If the selected language is not available, SYNC remains in the current active language.</p>
		<p>SYNC offers several new voice control features for a wide range of languages. Dialing a contact name directly from the phonebook without pre-recording (for example, "call John Smith") or selecting a track, artist, album, genre or playlist directly from your media player (for example, play artist Madonna).</p>

Navigation

Press the relevant button on the unit bezel to access the system functions. This will take you into the selected mode.

For instructions on how to operate the audio unit and the available navigation features, see the relevant audio unit procedure. See **Audio System** (page 207).

Loading Map Data

WARNINGS



The indicated maximum speed may not be applicable to your vehicle. It is always your responsibility to control your vehicle, supervise any system and obey the correct speed limit. Failure to do so could result in loss of vehicle control.



The front glass on the liquid crystal display may break if hit with a hard object. If the glass breaks, do not touch the liquid crystalline material. In case of contact with the skin, wash immediately with soap and water.

Note: Do not switch the ignition on or attempt to start the engine while the software is updating.

Note: Do not clean the unit with solvents or aerosol cleaning agents. Use only a damp cloth.

Note: The navigation SD card must be in the SD card slot to operate the navigation system. If you need a replacement SD card, see an authorized dealer.

Note: The SD card slot is spring-loaded. To remove the SD card, push the card in and release it. Do not attempt to remove the card without first pushing it in. This could cause damage.



E129900

1. Load the navigation SD card into the slot.
2. Press the **NAV** button. The road safety warning confirms the map data import was successful.
3. The system is now ready to use.

For map updates and system upgrades, see an authorized dealer.

Note: You can only use Ford licensed data.

Road Safety

WARNING



Driving while distracted can result in loss of vehicle control, crash and injury. We strongly recommend that you use extreme caution when using any device that may take your focus off the road. Your primary responsibility is the safe operation of your vehicle. We recommend against the use of any handheld device while driving and encourage the use of voice-operated systems when possible. Make sure you are aware of all applicable local laws that may affect the use of electronic devices while driving.

Navigation

Note: You are ultimately responsible for the safe operation of your vehicle and must evaluate whether it is safe to follow route suggestions. Navigation features are provided only as an aid. Driving decisions based on observations of local conditions and existing traffic regulations must be observed. Do not follow route suggestions if they would result in an unsafe or illegal maneuver, an unsafe situation, or if you would be directed into an area that you consider unsafe. Maps used by this system may be inaccurate due to errors, changes in roads, traffic or driving conditions.

Safety Information

If detailed viewing of route instructions is necessary, pull off the road when it is safe to do so and park your vehicle.

Setting a Route

Note: After the first entry, the country selected will remain the default option until you manually change it.

Press the **NAV** button and select:

Message	Action
Destination input	Starting at the top, select the country followed by either the postcode or city and street name, together with the house number or intersection. Use the arrow buttons to enter the destination details.
Start guidance	Select this after entering sufficient information.

The route is calculated and the screen returns to the main navigation screen. If prompted, select the type of route you require first. Follow the screen and voice prompts to reach your destination.

Note: If required you can select different character screens by using the up and down arrow buttons.

Note: If you only need to navigate to a city center, just enter the city name and start guidance.

Note: If you only need to navigate to a district, within a city for example, just enter the district name and start guidance.

Menu Structure

You can access the menu using the information and entertainment display control. See **Information Displays** (page 62).

For a description on some menu items refer to the relevant table.

Note: Some options may appear slightly different or not at all if the items are optional.

Message	
Route	Active guidance
	Route sections list
	Block next section

Navigation

Message		
	Unblock route sections	
Destination input	Country	
	City/postcode	
	Street	
	District	
	Start guidance	
Traffic	TA	
	TMC for route	
	All TMC	
	Block next section	
	Route sections list	
	Unblock route sections	
Home address	Start guidance	
	Change address	
Last destinations		
Favourites	Favourites (A-Z)	
Points of interest	POIs nearby	
	Near destination	
	Along motorway	
	POIs near address	
	Search by name	
Tour planning	New tour	
	Stored tours	
Store position		
Route options	Route	Eco
		Fast
		Short

Navigation

Message	
	Always ask
	Driver:
	Leisurely
	Normal
	Fast
	Eco settings
	Trailer:
	Roof box
	Dynamic
	Motorway
	Tunnel
	Ferry/motorail
Toll	
Seasonal roads	
Toll sticker	
Special functions	GPS info
	System info
	Enter position
	Demo mode

Route Options

Press the **NAV** button and scroll to route options. You can then set your route options for any of the following.

Message	Description and Action
Route: Always ask	Select to make sure that you are always given the choice of route option for your journey.
Eco	Uses the most fuel efficient route. Your driving style will influence this.
Fast	Uses the fastest route possible.

Navigation

Message		Description and Action
Short		Uses the shortest distance possible.
Driver:	Leisurely	This option will calculate your time of arrival based on a leisurely drive to the destination.
	Normal	This option will calculate your time of arrival based on a normal drive to the destination.
	Fast	This option will calculate your time of arrival based on a fast drive to the destination.
Eco settings	Trailer:	Use this feature to change the economy settings of your journey relating to whether or not you are towing a trailer and if so the size of trailer being towed.
	Roof box	Use this feature to change the economy settings of your journey relating to the use of a roof box.
	Dynamic	When switched on, and if the unit is receiving a valid traffic message channel signal, the route will be automatically updated to take into account real time traffic incidents or congestion. This feature can be useful in avoiding delays or hold ups on journeys.
	Motorway	When switched off the system will avoid freeways on your route and automatically update your route distance and timings.
	Tunnel	When switched off the system will avoid tunnels on your route and automatically update your route distance and timings.
	Ferry/motorail	When switched off the system will avoid ferry crossings and car train facilities on your route and automatically update your route distance and timings.

Navigation

Message		Description and Action
	Toll	When switched off the system will avoid toll roads on your route and automatically update your route distance and timings.
	Seasonal roads	When switched off the system will avoid seasonal roads (for example, mountain passes) on your route and automatically update your route distance and timings.
	Toll sticker	When switched off the system will avoid toll routes and automatically update your route distance and timings.

Information

Press the information button to view details of your current location or journey. During active route guidance pressing this button will repeat the last navigation instruction.

Setting Your Navigation Preferences

Select settings for the system to take into account when planning your route.

Press the NAV button and choose any of the following options.

Message	Description and Action
Destination input	Enter your destination details (for example enter city names, enter street names or pick a place from a map).
Traffic	Choose how you want the system to handle traffic problems along your route (for example, block sections on route).
Home address	See the location on the map currently stored as the home position. Only one entry can be saved as the home address.
Last destinations	Access a history of previous destinations entered in the system. Select the required repeat destination from the list.
Favourites	See a list of your saved favorites.
Points of interest	Search for and select points of interest nearby, on your route or at your destination. You can search by name or by category.
Tour planning	Set up and store a new tour by entering a number of different destinations and select the order in which you wish to visit them. You can also modify an existing tour or recall a previous tour. The system will automatically calculate and display your chosen journey.

Navigation

Message	Description and Action
Store position	Store and name your current position. This will automatically save in your favorites.
Route options	Set your route options from the available list.
Special functions	Select GPS and system information or a demonstration of the system functionality. Select a demonstration mode where the system will simulate a journey whilst the vehicle is stationary. You can manually select a vehicle start position.

Press the MENU button, select the navigation option and choose any of the following options.

Message	Description and Action
Route options	Set your route options.
Map display	Customize the map display for your journey (for example arrows on map, arrival times and map content).
Assistance options	Customize display information for your journey (for example signs, lanes and speed limits). Turn the hazard warning feature on or off.
Personal data	Delete personal data (for example your home address).
Reset all settings	Reset the navigation settings.

Storing Your Home Address

1. Press the **NAV** button.
2. Select the home address option.
3. Enter the required details using the arrow buttons.
4. Press the confirm function button.

Note: *Your last destination will automatically display if you go to change your home address.*

Adding a Favorite

1. Press the **NAV** button.
2. Scroll to the destination input option.

3. Enter the required details using the arrow buttons.
4. Press the store function button.

Note: *If you select store position, this will also save the destination in your favorites.*

Selecting a Favorite

1. Press the **NAV** button.
2. Select the favorites option.
3. Scroll to the required destination using the arrow buttons.
4. Press the **OK** button to start navigation.

Navigation

Adjusting the Navigation Voice Level

You can adjust the voice prompt level during an active voice prompt by using the volume control.

Note: *During active route guidance pressing the information button will repeat the last navigation instruction.*

Nav Audio Mixing

This feature allows you to adjust the volume mix between the audio unit and navigation voice level.

Tolerant Destination Input

This function will search a number of destinations with a similar spelling to what you have entered. This is helpful if you are unsure on how to spell a destination.

Message	Action
Tolerant	Press the NAV button and scroll to this destination input option before entering your destination details.

Then begin to input your destination. Press the **OK** button. The system will search for destinations with similar spellings. Use the arrow buttons to select a destination from the list and press the **OK** button to confirm your destination.

Route Displays

Map Display

Press the **MAP** button to view map mode. This view will show your current location with your vehicle in the center shown as an arrow surrounded by a circle. The arrow will face in the direction of travel.

The information on the top line gives the name of the current road, or the next road to take if a turn is approaching.

You can change the way the map is displayed by altering the zoom and orientation settings. Press function button one. The current map scale is shown on the display.

Map scale settings may be set between 0.05 miles to 500 miles or 50 meters to 500 kilometers, with an auto setting on the top. The auto setting continuously changes the map scale according to vehicle speed and the road type being driven.

You can use the arrow buttons to change the view to 2D, turn-by-turn, 3D or a clean view.

Zoom

This feature will automatically increase the zoom on the map display at times when you are required to make a turn, or perform more complex maneuvers. Shortly after the zoom scale will return to the previous level when in auto mode.

Manual: Press function button one and adjust the setting using the left or right arrow buttons. Press **OK** to confirm your setting.

Auto: Press function button one and using the up or down arrow key select the auto option. Press **OK** to confirm your setting.

Navigation

Move

When you are in map mode, press function button two. You can now use the arrow buttons on the audio unit to move around the map.

Press function button two again to return to the original view.

Navigation Display

After commencing a navigation route, the default screen is the main navigation screen.

Once an active route is underway, guidance will be given by on-screen information and voice prompts. Whichever audio source you wish to leave the unit in, basic turn by turn and distance information will remain on the screen in the form of a graphic inset. You do not need to leave the unit on the main navigation screen when you are navigating a route. Press the **MAP** button at any time to return to the main navigation screen. Slightly more detailed information on your route may be available using the main navigation screen if required.

Hazard Spot Warning

The system supports a hazard spot warning feature which informs you with visible and audible feedback about hazardous traffic areas.

Message	Description
Assistance options	You can switch the system on and off using the information and entertainment display menu. Refer to this option in the navigation menu.

Note: *This feature is only available in certain countries.*

Navigation Map Updates

Annual navigation map updates are available for purchase. See an authorized dealer.

SD Logo is a trademark.

The navigation software is based in part on the work of the FreeType team © 2006

The navigation software is based in part on the work of the independent JPEG Group.

Type Approvals



Appendices

ELECTROMAGNETIC COMPATIBILITY

WARNINGS

 Your vehicle has been tested and certified to legislation relating to electromagnetic compatibility (72/245/EEC, UN ECE Regulation 10 or other applicable local requirements). It is your responsibility to make sure that any equipment you have fitted complies with applicable local legislation. Have any equipment fitted by an authorized dealer.

 Radio frequency transmitter equipment (e.g. cell phones, amateur radio transmitters etc.) may only be fitted to your vehicle if they comply with the parameters shown in the table below. There are no special provisions or conditions for installations or use.

WARNINGS

 Do not mount any transceiver, microphones, speakers, or any other item in the deployment path of the airbag system.

 Do not fasten antenna cables to original vehicle wiring, fuel pipes and brake pipes.

 Keep antenna and power cables at least 4 inches (10 centimeters) from any electronic modules and airbags.

Note: *Only fit antennae in the positions shown to the roof of your vehicle.*

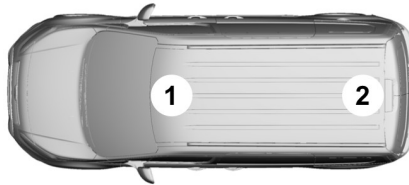

E164941

Frequency Band MHz	Maximum output power Watt (Peak RMS)	Antenna Positions
1 – 30	50 W	2
30 – 54	50 W	1, 2
68 – 87.5	50 W	1, 2
142 – 176	50 W	1, 2
380 – 512	50 W	1, 2

Appendices

Frequency Band MHz	Maximum output power Watt (Peak RMS)	Antenna Positions
806 – 940	10 W	1, 2
1200 – 1400	10 W	1, 2
1710 – 1885	10 W	1, 2
1885 – 2025	10 W	1, 2

Note: After the installation of radio frequency transmitters, check for disturbances from and to all electrical equipment in your vehicle, both in the standby and transmit modes.

Check all electrical equipment:

- with the ignition on
- with the engine running
- during a road test at various speeds.

Check that electromagnetic fields generated inside your vehicle cabin by the transmitter installed do not exceed applicable human exposure requirements.

END USER LICENSE AGREEMENT

SYNC® End User License Agreement (EULA)

- You have acquired a device ("DEVICE") that includes software licensed by Ford Motor Company and its affiliates ("FORD MOTOR COMPANY") from an affiliate of Microsoft Corporation ("MS"). Those installed software products of MS origin, as well as associated media, printed materials,

and "online" or electronic documentation ("MS SOFTWARE") are protected by international intellectual property laws and treaties. The MS SOFTWARE is licensed, not sold. All rights reserved.

- The MS SOFTWARE may interface with and/or communicate with, or may be later upgraded to interface with and/or communicate with additional software and/or systems provided by FORD MOTOR COMPANY. The additional software and systems of FORD MOTOR COMPANY origin, as well as associated media, printed materials, and "online" or electronic documentation ("FORD SOFTWARE") are protected by international intellectual property laws and treaties. The FORD SOFTWARE is licensed, not sold. All rights reserved.

Appendices

- The MS SOFTWARE and/or FORD SOFTWARE may interface with and/or communicate with, or may be later upgraded to interface with and/or communicate with additional software and/or systems provided by third party software and service suppliers. The additional software and services of third party origin, as well as associated media, printed materials, and "online" or electronic documentation ("THIRD PARTY SOFTWARE") are protected by international intellectual property laws and treaties. The THIRD PARTY SOFTWARE is licensed, not sold. All rights reserved.
- The MS SOFTWARE, FORD SOFTWARE and THIRD PARTY SOFTWARE hereinafter collectively and individually will be referred to as "SOFTWARE".

IF YOU DO NOT AGREE TO THIS END USER LICENSE AGREEMENT ("EULA") DO NOT USE THE DEVICE OR COPY THE SOFTWARE. ANY USE OF THE SOFTWARE, INCLUDING BUT NOT LIMITED TO USE ON THE DEVICE, WILL CONSTITUTE YOUR AGREEMENT TO THIS EULA (OR RATIFICATION OF ANY PREVIOUS CONSENT).

GRANT OF SOFTWARE LICENSE: This EULA grants you the following license:

- You may use the SOFTWARE as installed on the DEVICE and as otherwise interfacing with systems and/or services provide by or through FORD MOTOR COMPANY or its third party software and service providers.

Description of Other Rights and Limitations

- **Speech Recognition:** If the SOFTWARE includes speech recognition component(s), you should understand that speech recognition is an inherently statistical process and that recognition errors are inherent in the process. Neither FORD MOTOR COMPANY nor its suppliers shall be liable for any damages arising out of errors in the speech recognition process.
- **Limitations on Reverse Engineering, Decompilation and Disassembly:** You may not reverse engineer, decompile, or disassemble nor permit others to reverse engineer, decompile or disassemble the SOFTWARE, except and only to the extent that such activity is expressly permitted by applicable law notwithstanding this limitation.
- **Limitations on Distributing, Copying, Modifying and Creating Derivative Works:** You may not distribute, copy, make modifications to or create derivative works based on the SOFTWARE, except and only to the extent that such activity is expressly permitted by applicable law notwithstanding this limitation.
- **Single EULA:** The end user documentation for the DEVICE and related systems and services may contain multiple EULAs, such as multiple translations and/or multiple media versions (e.g., in the user documentation and in the software). Even if you receive multiple EULAs, you are licensed to use only one (1) copy of the SOFTWARE.

Appendices

- **SOFTWARE Transfer:** You may permanently transfer your rights under this EULA only as part of a sale or transfer of the DEVICE, provided you retain no copies, you transfer all of the SOFTWARE (including all component parts, the media and printed materials, any upgrades, and, if applicable, the Certificate(s) of Authenticity), and the recipient agrees to the terms of this EULA. If the SOFTWARE is an upgrade, any transfer must include all prior versions of the SOFTWARE.
- **Termination:** Without prejudice to any other rights, FORD MOTOR COMPANY or MS may terminate this EULA if you fail to comply with the terms and conditions of this EULA.
- **Security Updates/Digital Rights Management:** Content owners use the WMDRM technology included in your DEVICE to protect their intellectual property, included copyrighted content. Portions of the SOFTWARE on your DEVICE use WMDRM software to access WMDRM-protected content. If the WMDRM software fails to protect the content, content owners may ask Microsoft to revoke the SOFTWARE's ability to use WMDRM to play or copy protected content. This action does not affect unprotected content. When your DEVICE downloads licenses for protected content, you agree that Microsoft may include a revocation list with the licenses. Content owners may require you to upgrade the SOFTWARE on your DEVICE to access their content. If you decline an upgrade, you will not be able to access content that requires the upgrade.
- **Consent to Use of Data:** You agree that MS, Microsoft Corporation, FORD MOTOR COMPANY, third party software and systems suppliers, their affiliates and/or their designated agent may collect and use technical information gathered in any manner as part of product support services related to the SOFTWARE or related services. MS, Microsoft Corporation, FORD MOTOR COMPANY, third party software and services suppliers, their affiliates and/or their designated agent may use this information solely to improve their products or to provide customized services or technologies to you. MS, Microsoft Corporation, FORD MOTOR COMPANY, third party software and systems suppliers, their affiliates and/or their designated agent may disclose this information to others, but not in a form that personally identifies you.
- **Internet-Based Services Components:** The SOFTWARE may contain components that enable and facilitate the use of certain Internet-based services. You acknowledge and agree that MS, Microsoft Corporation, FORD MOTOR COMPANY, third party software and service suppliers, their affiliates and/or their designated agent may automatically check the version of the SOFTWARE and/or its components that you are utilizing and may provide upgrades or supplements to the SOFTWARE that may be automatically downloaded to your DEVICE.
- **Additional Software/Services:** The SOFTWARE may permit FORD MOTOR COMPANY, third party software and service suppliers, MS, Microsoft Corporation, their affiliates and/or their designated agent to provide or make available to you SOFTWARE updates,

Appendices

supplements, add-on components, or Internet-based services components of the SOFTWARE after the date you obtain your initial copy of the SOFTWARE ("Supplemental Components").

If FORD MOTOR COMPANY or third party software and services suppliers provide or make available to you Supplemental Components and no other EULA terms are provided along with the Supplemental Components, then the terms of this EULA shall apply.

If MS, Microsoft Corporation, their affiliates and/or their designated agent make available Supplemental Components, and no other EULA terms are provided, then the terms of this EULA shall apply, except that the MS, Microsoft Corporation or affiliate entity providing the Supplemental Component(s) shall be the licensor of the Supplemental Component(s).

FORD MOTOR COMPANY, MS, Microsoft Corporation, their affiliates and/or their designated agent reserve the right to discontinue without liability any Internet-based services provided to you or made available to you through the use of the SOFTWARE.

- **Links to Third Party Sites:** The MS SOFTWARE may provide you with the ability to link to third party sites through the use of the SOFTWARE. The third party sites are not under the control of MS, Microsoft Corporation, their affiliates and/or their designated agent. Neither MS nor Microsoft Corporation nor their affiliates nor their designated agent are responsible for (i) the contents of any third party sites, any links contained in third party sites, or any changes or updates to third party sites, or (ii) webcasting or any other form of transmission received from any third party sites. If the SOFTWARE provides links to third party sites, those links are provided to you only as a convenience, and the inclusion of any link does not imply an endorsement of the third party site by MS, Microsoft Corporation, their affiliates and/or their designated agent.
- **Obligation to Drive Responsibly:** You recognize your obligation to drive responsibly and keep attention on the road. You will read and abide with the DEVICE operating instructions particularly as they pertain to safety and assumes any risk associated with the use of the DEVICE.

UPGRADES AND RECOVERY MEDIA:

If the SOFTWARE is provided by FORD MOTOR COMPANY separate from the DEVICE on media such as a ROM chip, CD ROM disk(s) or via web download or other means, and is labeled "For Upgrade Purposes Only" or "For Recovery Purposes Only" you may install one (1) copy of such SOFTWARE onto the DEVICE as a replacement copy for the existing SOFTWARE, and use it in accordance with this EULA, including any additional EULA terms accompanying the upgrade SOFTWARE.

Appendices

INTELLECTUAL PROPERTY RIGHTS:

All title and intellectual property rights in and to the SOFTWARE (including but not limited to any images, photographs, animations, video, audio, music, text and "applets" incorporated into the SOFTWARE), the accompanying printed materials, and any copies of the SOFTWARE, are owned by MS, Microsoft Corporation, FORD MOTOR COMPANY, or their affiliates or suppliers. The SOFTWARE is licensed, not sold. You may not copy the printed materials accompanying the SOFTWARE. All title and intellectual property rights in and to the content which may be accessed through use of the SOFTWARE is the property of the respective content owner and may be protected by applicable copyright or other intellectual property laws and treaties. This EULA grants you no rights to use such content. All rights not specifically granted under this EULA are reserved by MS, Microsoft Corporation, FORD MOTOR COMPANY, third party software and service providers, their affiliates and suppliers. Use of any on-line services which may be accessed through the SOFTWARE may be governed by the respective terms of use relating to such services. If this SOFTWARE contains documentation that is provided only in electronic form, you may print one copy of such electronic documentation.

EXPORT RESTRICTIONS: You acknowledge that the SOFTWARE is subject to U.S. and European Union export jurisdiction. You agree to comply with all applicable international and national laws that apply to the SOFTWARE, including the U.S. Export Administration Regulations, as well as end-user, end-use and destination restrictions issued by U.S. and other governments. For additional information, see <http://www.microsoft.com/exporting/>.

TRADEMARKS: This EULA does not grant you any rights in connection with any trademarks or service marks of FORD MOTOR COMPANY, MS, Microsoft Corporation, third party software or service providers, their affiliates or suppliers.

PRODUCT SUPPORT: Product support for the SOFTWARE is not provided by MS, its parent corporation Microsoft Corporation, or their affiliates or subsidiaries. For product support, please refer to FORD MOTOR COMPANY instructions provided in the documentation for the DEVICE. Should you have any questions concerning this EULA, or if you desire to contact FORD MOTOR COMPANY for any other reason, please refer to the address provided in the documentation for the DEVICE.

No Liability for Certain Damages: EXCEPT AS PROHIBITED BY LAW, FORD MOTOR COMPANY, ANY THIRD PARTY SOFTWARE OR SERVICES SUPPLIERS, MS, MICROSOFT CORPORATION AND THEIR AFFILIATES SHALL HAVE NO LIABILITY FOR ANY INDIRECT, SPECIAL, CONSEQUENTIAL OR INCIDENTAL DAMAGES ARISING FROM OR IN CONNECTION WITH THE USE OR PERFORMANCE OF THE SOFTWARE. THIS LIMITATION SHALL APPLY EVEN IF ANY REMEDY FAILS OF ITS ESSENTIAL PURPOSE. IN NO EVENT SHALL MS, MICROSOFT CORPORATION AND/OR THEIR AFFILIATES BE LIABLE FOR ANY AMOUNT IN EXCESS OF U.S. TWO HUNDRED FIFTY DOLLARS (U.S. \$250.00).

- THERE ARE NO WARRANTIES OTHER THAN THOSE THAT MAY EXPRESSLY BE PROVIDED FOR YOUR NEW VEHICLE.

Appendices

Adobe

Contains Adobe® [Flash® Player] or [AIR®] technology by Adobe Systems Incorporated. This [Licensee Product] contains [Adobe® Flash® Player] [Adobe® AIR®] software under license from Adobe Systems Incorporated, Copyright ©1995-2009 Adobe Macromedia Software LLC. All rights reserved. Adobe, Flash and AIR are trademarks of Adobe Systems Incorporated.

End User Notice

Microsoft® Windows® Mobile for Automotive Important Safety Information

This system Ford SYNC™ contains software that is licensed to Manufacturer FORD MOTOR COMPANY by an affiliate of Microsoft Corporation pursuant to a license agreement. Any removal, reproduction, reverse engineering or other unauthorized use of the software from this system in violation of the license agreement is strictly prohibited and may subject you to legal action.

Read and follow instructions: Before using your Windows Automotive-based system, read and follow all instructions and safety information provided in this end user manual ("User's Guide"). Not following precautions found in this User's Guide can lead to an accident or other serious consequences.

Keep User's Guide in vehicle: When kept in the vehicle, the User's Guide will be a ready reference for you and other users unfamiliar with the Windows Automotive-based system. Please make certain that before using the system for the first time, all persons have access to the User's Guide and read its instructions and safety information carefully.

WARNING



Operating certain parts of this system while driving can distract your attention away from the road, and possibly cause an accident or other serious consequences. Do not change system settings or enter data non-verbally (using your hands) while driving. Stop the vehicle in a safe and legal manner before attempting these operations. This is important since while setting up or changing some functions you might be required to distract your attention away from the road and remove your hands from the wheel.

General Operation

Voice Command Control: Functions within the Windows Automotive-based system may be accomplished using only voice commands. Using voice commands while driving allows you to operate the system without removing your hands from the wheel.

Prolonged Views of Screen: Do not access any function requiring a prolonged view of the screen while you are driving. Pull over in a safe and legal manner before attempting to access a function of the system requiring prolonged attention. Even occasional short scans to the screen may be hazardous if your attention has been diverted away from your driving task at a critical time.

Volume Setting: Do not raise the volume excessively. Keep the volume at a level where you can still hear outside traffic and emergency signals while driving. Driving while unable to hear these sounds could cause an accident.

Appendices

Use of Speech Recognition Functions:

Speech recognition software is inherently a statistical process which is subject to errors. It is your responsibility to monitor any speech recognition functions included in the system and address any errors.

Navigation Features: Any navigation features included in the system are intended to provide turn by turn instructions to get you to a desired destination. Please make certain all persons using this system carefully read and follow instructions and safety information fully.

Distraction Hazard: Any navigation features may require manual (non-verbal) setup. Attempting to perform such set-up or insert data while driving can seriously distract your attention and could cause an accident or other serious consequences. Stop the vehicle in a safe and legal manner before attempting these operations.

Let Your Judgment Prevail: Any navigation features are provided only as an aid. Make your driving decisions based on your observations of local conditions and existing traffic regulations. Any such feature is not a substitute for your personal judgment. Any route suggestions made by this system should never replace any local traffic regulations or your personal judgment or knowledge of safe driving practices.

Route Safety: Do not follow the route suggestions if doing so would result in an unsafe or illegal maneuver, if you would be placed in an unsafe situation, or if you would be directed into an area that you consider unsafe. The driver is ultimately responsible for the safe operation of the vehicle and therefore, must evaluate whether it is safe to follow the suggested directions.

Potential Map Inaccuracy: Maps used by this system may be inaccurate because of changes in roads, traffic controls or driving conditions. Always use good judgment and common sense when following the suggested routes.

Emergency Services: Do not rely on any navigation features included in the system to route you to emergency services. Ask local authorities or an emergency services operator for these locations. Not all emergency services such as police, fire stations, hospitals and clinics are likely to be contained in the map database for such navigation features.

TeleNav Software End User License Agreement

Please read these terms and conditions carefully before you use the TeleNav Software. Your use of the TeleNav Software indicates that you accept these terms and conditions. If you do not accept these terms and conditions, do not break the seal of the package, launch, or otherwise use the TeleNav Software.

TeleNav may revise this Agreement and the privacy policy at any time, with or without notice to you. You agree to visit <http://www.telenav.com> from time to time to review the then current version of this Agreement and of the privacy policy.

1. Safe and Lawful Use

You acknowledge that devoting attention to the TeleNav Software may pose a risk of injury or death to you and others in situations that otherwise require your undivided attention, and you therefore agree to comply with the following when using the TeleNav Software: (a) observe all traffic laws and otherwise drive safely; (b) use your own personal judgment while driving. If you feel that a route suggested by the TeleNav Software instructs you to perform an unsafe or illegal maneuver,

Appendices

places you in an unsafe situation, or directs you into an area that you consider to be unsafe, do not follow such instructions; (c) do not input destinations, or otherwise manipulate the TeleNav Software, unless your vehicle is stationary and parked; (d) do not use the TeleNav Software for any illegal, unauthorized, unintended, unsafe, hazardous, or unlawful purposes, or in any manner inconsistent with this Agreement; (e) arrange all GPS and wireless devices and cables necessary for use of the TeleNav Software in a secure manner in your vehicle so that they will not interfere with your driving and will not prevent the operation of any safety device (such as an airbag).

You agree to indemnify and hold TeleNav harmless against all claims resulting from any dangerous or otherwise inappropriate use of the TeleNav Software in any moving vehicle, including as a result of your failure to comply with the directions above.

2. Account Information

You agree: (a) when registering the TeleNav Software, to provide TeleNav with true, accurate, current, and complete information about yourself, and (b) to inform TeleNav promptly of any changes to such information, and to keep it true, accurate, current and complete.

3. Software License

Subject to your compliance with the terms of this Agreement, TeleNav hereby grants to you a personal, non-exclusive, non-transferable license (except as expressly permitted below in connection with your permanent transfer of the TeleNav Software license), without the right to sublicense, to use the TeleNav Software (in object code form only) in order to access and use the TeleNav Software. This license shall terminate upon

any termination or expiration of this Agreement. You agree that you will use the TeleNav Software only for your personal business or leisure purposes, and not to provide commercial navigation services to other parties.

3.1 License Limitations

You agree not to do any of the following: (a) reverse engineer, decompile, disassemble, translate, modify, alter or otherwise change the TeleNav Software or any part thereof; (b) attempt to derive the source code, audio library or structure of the TeleNav Software without the prior express written consent of TeleNav; (c) remove from the TeleNav Software, or alter, any of TeleNav's or its suppliers' trademarks, trade names, logos, patent or copyright notices, or other notices or markings; (d) distribute, sublicense or otherwise transfer the TeleNav Software to others, except as part of your permanent transfer of the TeleNav Software; or (e) use the TeleNav Software in any manner that (i) infringes the intellectual property or proprietary rights, rights of publicity or privacy or other rights of any party, (ii) violates any law, statute, ordinance or regulation, including but not limited to laws and regulations related to spamming, privacy, consumer and child protection, obscenity or defamation, or (iii) is harmful, threatening, abusive, harassing, tortuous, defamatory, vulgar, obscene, libelous, or otherwise objectionable; and (f) lease, rent out, or otherwise permit unauthorized access by third parties to the TeleNav Software without advanced written permission of TeleNav.

Appendices

4. Disclaimers

To the fullest extent permissible pursuant to applicable law, in no event will TeleNav, its licensors and suppliers, or agents or employees of any of the foregoing, be liable for any decision made or action taken by you or anyone else in reliance on the information provided by the TeleNav Software. TeleNav also does not warrant the accuracy of the map or other data used for the TeleNav Software. Such data may not always reflect reality due to, among other things, road closures, construction, weather, new roads and other changing conditions. You are responsible for the entire risk arising out of your use of the TeleNav Software. For example but without limitation, you agree not to rely on the TeleNav Software for critical navigation in areas where the well-being or survival of you or others is dependent on the accuracy of navigation, as the maps or functionality of the TeleNav Software are not intended to support such high risk applications, especially in more remote geographical areas.

TELENAV EXPRESSLY DISCLAIMS AND EXCLUDES ALL WARRANTIES IN CONNECTION WITH THE TELENAV SOFTWARE, WHETHER STATUTORY, EXPRESS OR IMPLIED, INCLUDING ALL WARRANTIES WHICH MAY ARISE FROM COURSE OF DEALING, CUSTOM OR TRADE AND INCLUDING, BUT NOT LIMITED TO, THE IMPLIED WARRANTIES OF MERCHANTABILITY, FITNESS FOR A PARTICULAR PURPOSE AND NON-INFRINGEMENT OF THIRD PARTY RIGHTS WITH RESPECT TO THE TELENAV SOFTWARE. Certain jurisdictions do not permit the disclaimer of certain warranties, so this limitation may not apply to you.

5. Limitation of Liability

TO THE EXTENT PERMITTED UNDER APPLICABLE LAW, UNDER NO CIRCUMSTANCES SHALL TELENAV OR ITS LICENSORS AND SUPPLIERS BE LIABLE TO YOU OR TO ANY THIRD PARTY FOR ANY INDIRECT, INCIDENTAL, CONSEQUENTIAL, SPECIAL OR EXEMPLARY DAMAGES (INCLUDING IN EACH CASE, BUT NOT LIMITED TO, DAMAGES FOR THE INABILITY TO USE THE EQUIPMENT OR ACCESS DATA, LOSS OF DATA, LOSS OF BUSINESS, LOSS OF PROFITS, BUSINESS INTERRUPTION OR THE LIKE) ARISING OUT OF THE USE OF OR INABILITY TO USE THE TELENAV SOFTWARE, EVEN IF TELENAV HAS BEEN ADVISED OF THE POSSIBILITY OF SUCH DAMAGES.

NOTWITHSTANDING ANY DAMAGES THAT YOU MIGHT INCUR FOR ANY REASON WHATSOEVER (INCLUDING, WITHOUT LIMITATION, ALL DAMAGES REFERENCED HEREIN AND ALL DIRECT OR GENERAL DAMAGES IN CONTRACT, TORT (INCLUDING NEGLIGENCE) OR OTHERWISE), THE ENTIRE LIABILITY OF TELENAV AND OF ALL OF TELENAV'S SUPPLIERS SHALL BE LIMITED TO THE AMOUNT ACTUALLY PAID BY YOU FOR THE TELENAV SOFTWARE. SOME STATES AND/OR JURISDICTIONS DO NOT ALLOW THE EXCLUSION OR LIMITATION OF INCIDENTAL OR CONSEQUENTIAL DAMAGES, SO THE ABOVE LIMITATIONS OR EXCLUSIONS MAY NOT APPLY TO YOU.

6. Arbitration and Governing Law

You agree that any dispute, claim or controversy arising out of or relating to this Agreement or the TeleNav Software shall be settled by independent arbitration involving a neutral arbitrator and administered by the American Arbitration Association in the County of Santa Clara, California. The arbitrator shall apply the

Appendices

Commercial Arbitration Rules of the American Arbitration Association, and the judgment upon the award rendered by the arbitrator may be entered by any court having jurisdiction. Note that there is no judge or jury in an arbitration proceeding and the decision of the arbitrator shall be binding upon both parties. You expressly agree to waive your right to a jury trial.

This Agreement and performance hereunder will be governed by and construed in accordance with the laws of the State of California, without giving effect to its conflict of laws provisions. To the extent judicial action is necessary in connection with the binding arbitration, both TeleNav and you agree to submit to the exclusive jurisdiction of the courts of the County of Santa Clara, California. The United Nations Convention on Contracts for the International Sale of Goods shall not apply.

7. Assignment

You may not resell, assign, or transfer this Agreement or any of your rights or obligations, except in totality, in connection with your permanent transfer of the TeleNav Software, and expressly conditioned upon the new user of the TeleNav Software agreeing to be bound by the terms and conditions of this Agreement. Any such sale, assignment or transfer that is not expressly permitted under this paragraph will result in immediate termination of this Agreement, without liability to TeleNav, in which case you and all other parties shall immediately cease all use of the TeleNav Software. Notwithstanding the foregoing, TeleNav may assign this Agreement to any other party at any time without notice, provided the assignee remains bound by this Agreement.

8. Miscellaneous

8.1

This Agreement constitutes the entire agreement between TeleNav and you with respect to the subject matter hereof.

8.2

Except for the limited licenses expressly granted in this Agreement, TeleNav retains all right, title and interest in and to the TeleNav Software, including without limitation all related intellectual property rights. No licenses or other rights which are not expressly granted in this Agreement are intended to, or shall be, granted or conferred by implication, statute, inducement, estoppel or otherwise, and TeleNav and its suppliers and licensors hereby reserve all of their respective rights other than the licenses explicitly granted in this Agreement

8.3

By using the TeleNav Software, you consent to receive from TeleNav all communications, including notices, agreements, legally required disclosures or other information in connection with the TeleNav Software (collectively, "Notices") electronically. TeleNav may provide such Notices by posting them on TeleNav's Website or by downloading such Notices to your wireless device. If you desire to withdraw your consent to receive Notices electronically, you must discontinue your use of the TeleNav Software.

8.4

TeleNav's or your failure to require performance of any provision shall not affect that party's right to require performance at any time thereafter, nor shall a waiver of any breach or default of this Agreement constitute a waiver of any subsequent breach or default or a waiver of the provision itself.

Appendices

8.5

If any provision herein is held unenforceable, then such provision will be modified to reflect the intention of the parties, and the remaining provisions of this Agreement will remain in full force and effect

8.6

The headings in this Agreement are for convenience of reference only, will not be deemed to be a part of this Agreement, and will not be referred to in connection with the construction or interpretation of this Agreement. As used in this Agreement, the words "include" and "including" and variations thereof, will not be deemed to be terms of limitation, but rather will be deemed to be followed by the words "without limitation".

9. Other Vendors Terms and Conditions

The TeleNav Software utilizes map and other data licensed to TeleNav by third party vendors for the benefit of you and other end users. This Agreement includes end-user terms applicable to these companies (included at the end of this Agreement), and thus your use of the TeleNav Software is also subject to such terms. You agree to comply with the following additional terms and conditions, which are applicable to TeleNav's third party vendor licensors:

NavTeq End User License Agreement

END USER TERMS

The content provided ("Data") is licensed, not sold. By opening this package, or installing, copying, or otherwise using the Data, you agree to be bound by the terms of this agreement. If you do not agree to the terms of this agreement, you are not permitted to install, copy, use, resell or transfer the Data. If you wish to reject the terms of this agreement, and have not

installed, copied, or used the Data, you must contact your retailer or NAVTEQ North America, LLC ("NT") within thirty (30) days of purchase for a refund of your purchase price. To contact NT, please visit www.navteq.com.

The Data is provided for your personal, internal use only and may not be resold. It is protected by copyright, and is subject to the following terms (this "End User License Agreement") and conditions which are agreed to by you, on the one hand, and NAVTEQ North America, LLC ("NT") and its licensors (including their licensors and suppliers) on the other hand.

The Data for areas of Canada includes information taken with permission from Canadian authorities, including: © Her Majesty the Queen in Right of Canada, © Queen's Printer for Ontario, © Canada Post Corporation, GeoBase®.

NT holds a nonexclusive license from the United States Postal Service® to publish and sell ZIP+4® information.

© United States Postal Service® 2009. Prices are not established, controlled or approved by the United States Postal Service® The following trademarks and registrations are owned by the USPS: United States Postal Service, USPS, and ZIP+4.

The Data for Mexico includes certain Data from Instituto Nacional de Estadística y Geografía.

TERMS AND CONDITIONS

License Limitations on Use: You agree that your license to use this Data is limited to and conditioned on use for solely personal, noncommercial purposes, and not for service bureau, timesharing or other similar purposes. Except as otherwise set forth herein, you agree not to otherwise

Appendices

reproduce, copy, modify, decompile, disassemble or reverse engineer any portion of this Data, and may not transfer or distribute it in any form, for any purpose, except to the extent permitted by mandatory laws.

License Limitations on Transfer: Your limited license does not allow transfer or resale of the Data, except on the condition that you may transfer the Data and all accompanying materials on a permanent basis if: (a) you retain no copies of the Data; (b) the recipient agrees to the terms of this End User License Agreement; and (c) you transfer the Data in the exact same form as you purchased it by physically transferring the original media (e.g., the CD-ROM or DVD you purchased), all original packaging, all Manuals and other documentation. Specifically, Multi-disc sets may only be transferred or sold as a complete set as provided to you and not as a subset thereof.

Additional License Limitations: Except where you have been specifically licensed to do so by NT in a separate written agreement, and without limiting the preceding paragraph, your license is conditioned on use of the Data as prescribed in this agreement, and you may not (a) use this Data with any products, systems, or applications installed or otherwise connected to or in communication with vehicles capable of vehicle navigation, positioning, dispatch, real time route guidance, fleet management or similar applications; or (b) with, or in communication with, including without limitation, cellular phones, palmtop and handheld computers, pagers, and personal digital assistants or PDAs.

WARNING



This Data may contain inaccurate or incomplete information due to the passage of time, changing circumstances, sources used and the nature of collecting comprehensive geographic Data, any of which may lead to incorrect results.

No Warranty: This Data is provided to you "as is", and you agree to use it at your own risk. NT and its licensors (and their licensors and suppliers) make no guarantees, representations or warranties of any kind, express or implied, arising by law or otherwise, including but not limited to, content, quality, accuracy, completeness, effectiveness, reliability, fitness for a particular purpose, usefulness, use or results to be obtained from this Data, or that the Data or server will be uninterrupted or error free.

Disclaimer of Warranty: NT AND ITS LICENSORS (INCLUDING THEIR LICENSORS AND SUPPLIERS) DISCLAIM ANY WARRANTIES, EXPRESS OR IMPLIED, OF QUALITY, PERFORMANCE, MERCHANTABILITY, FITNESS FOR A PARTICULAR PURPOSE OR NON-INFRINGEMENT. Some States, Territories and Countries do not allow certain warranty exclusions, so to that extent the above exclusion may not apply to you.

Disclaimer of Liability: NT AND ITS LICENSORS (INCLUDING THEIR LICENSORS AND SUPPLIERS) SHALL NOT BE LIABLE TO YOU IN RESPECT OF ANY CLAIM, DEMAND OR ACTION, IRRESPECTIVE OF THE NATURE OF THE CAUSE OF THE CLAIM, DEMAND OR ACTION ALLEGING ANY LOSS, INJURY OR DAMAGES, DIRECT OR INDIRECT, WHICH MAY RESULT FROM THE USE OR POSSESSION OF THIS DATA; OR FOR ANY LOSS OF PROFIT, REVENUE, CONTRACTS

Appendices

OR SAVINGS, OR ANY OTHER DIRECT, INDIRECT, INCIDENTAL, SPECIAL OR CONSEQUENTIAL DAMAGES ARISING OUT OF YOUR USE OF OR INABILITY TO USE THIS DATA, ANY DEFECT IN THIS DATA, OR THE BREACH OF THESE TERMS OR CONDITIONS, WHETHER IN AN ACTION IN CONTRACT OR TORT OR BASED ON A WARRANTY, EVEN IF NT OR ITS LICENSORS HAVE BEEN ADVISED OF THE POSSIBILITY OF SUCH DAMAGES. Some States, Territories and Countries do not allow certain liability exclusions or damages limitations, so to that extent the above may not apply to you.

Export Control: You agree not to export from anywhere any part of the Data or any direct product thereof except in compliance with, and with all licenses and approvals required under, applicable export laws, rules and regulations, including but not limited to the laws, rules and regulations administered by the Office of Foreign Assets Control of the U.S. Department of Commerce and the Bureau of Industry and Security of the U.S. Department of Commerce. To the extent that any such export laws, rules or regulations prohibit NT from complying with any of its obligations hereunder to deliver or distribute Data, such failure shall be excused and shall not constitute a breach of this Agreement.

Entire Agreement: These terms and conditions constitute the entire agreement between NT (and its licensors, including their licensors and suppliers) and you pertaining to the subject matter hereof, and supersedes in their entirety any and all written or oral agreements previously existing between us with respect to such subject matter.

Severability: You and NT agree that if any portion of this agreement is found illegal or unenforceable, that portion shall be severed and the remainder of the Agreement shall be given full force and effect.

Governing Law: The above terms and conditions shall be governed by the laws of the State of Illinois, without giving effect to (i) its conflict of laws provisions, or (ii) the United Nations Convention for Contracts for the International Sale of Goods, which is explicitly excluded. You agree to submit to the personal jurisdiction of the State of Illinois for any and all disputes, claims and actions arising from or in connection with the Data provided to you hereunder.

Government End Users: If the Data is being acquired by or on behalf of the United States government or any other entity seeking or applying rights similar to those customarily claimed by the United States government, this Data is a "commercial term" as that term is defined at 48 C.F.R. ("FAR") 2.101, is licensed in accordance with this End User License Agreement, and each copy of Data delivered or otherwise furnished shall be marked and embedded as appropriate with the following "Notice of Use", and be treated in accordance with such Notice:

NOTICE OF USE

CONTRACTOR
(MANUFACTURER/SUPPLIER)

NAME:

NAVTEQ

CONTRACTOR
(MANUFACTURER/SUPPLIER)

ADDRESS:

**425 West Randolph Street, Chicago, IL
60606.**

Appendices

This Data is a commercial item as defined in FAR 2.101

and is subject to the End User License Agreement under

which this Data was provided.

© 2011 NAVTEQ. All rights reserved.

If the Contracting Officer, federal government agency, or any federal official refuses to use the legend provided herein, the Contracting Officer, federal government agency, or any federal official must notify NAVTEQ prior to seeking additional or alternative rights in the Data.

Wi-Fi hotspot data provided by JiWire, © 2013 JiWire.

Gracenote® Copyright

CD and music-related data from Gracenote, Inc., copyright© 2000-2007 Gracenote. Gracenote Software, copyright © 2000-2007 Gracenote. This product and service may practice one or more of the following U.S. Patents #5,987,525, #6,061,680, #6,154,773, #6,161,132, #6,230,192, #6,230,207, #6.240,459, #6,330,593 and other patents issued or pending. Some services supplied under license from Open Globe, Inc. for U.S. Patent: #6,304,523.

Gracenote and CDDB are registered trademarks of Gracenote. The Gracenote logo and logotype, and the "Powered by Gracenote™" logo are trademarks of Gracenote.

Gracenote® End User License Agreement (EULA)

This device contains software from Gracenote, Inc. of 2000 Powell Street Emeryville, California 94608 ("Gracenote").

The software from Gracenote (the "Gracenote Software") enables this device to do disc and music file identification and obtain music-related information, including name, artist, track, and title information ("Gracenote Data") from online servers ("Gracenote Servers"), and to perform other functions. You may use Gracenote Data only by means of the intended End User functions of this device.

This device may contain content belonging to Gracenote's providers. If so, all of the restrictions set forth herein with respect to Gracenote Data shall also apply to such content and such content providers shall be entitled to all of the benefits and protections set forth herein that are available to Gracenote.

You agree that you will use the content from Gracenote ("Gracenote Content"), Gracenote Data, the Gracenote Software, and Gracenote Servers for your own personal, non-commercial use only. You agree not to assign, copy, transfer or transmit the Gracenote Content, Gracenote Software or any Gracenote Data (except in a Tag associated with a music file) to any third party. YOU AGREE NOT TO USE OR EXPLOIT GRACENOTE CONTENT, GRACENOTE DATA, THE GRACENOTE SOFTWARE, OR GRACENOTE SERVERS, EXCEPT AS EXPRESSLY PERMITTED HEREIN.

You agree that your non-exclusive licenses to use the Gracenote Content, Gracenote Data, the Gracenote Software, and Gracenote Servers will terminate if you violate these restrictions. If your licenses terminate, you agree to cease any and all use of the Gracenote Content, Gracenote Data, the Gracenote Software, and Gracenote Servers. Gracenote, respectively, reserve all rights in Gracenote Data, the Gracenote Software, and the Gracenote Servers and Gracenote Content, including all ownership rights. Under no circumstances will either Gracenote

Appendices

become liable for any payment to you for any information that you provide, including any copyrighted material or music file information. You agree that Gracenote may enforce its respective rights, collectively or separately, under this agreement against you, directly in each company's own name.

Gracenote uses a unique identifier to track queries for statistical purposes. The purpose of a randomly assigned numeric identifier is to allow Gracenote to count queries without knowing anything about who you are. For more information, see the web page at www.gracenote.com for the Gracenote Privacy Policy.

THE GRACENOTE SOFTWARE, EACH ITEM OF GRACENOTE DATA AND THE GRACENOTE CONTENT ARE LICENSED TO YOU "AS IS". NEITHER GRACENOTE MAKES ANY REPRESENTATIONS OR WARRANTIES, EXPRESS OR IMPLIED, REGARDING THE ACCURACY OF ANY GRACENOTE DATA FROM THE GRACENOTE SERVERS OR GRACENOTE CONTENT. GRACENOTE COLLECTIVELY AND SEPARATELY RESERVE THE RIGHT TO DELETE DATA AND/OR CONTENT FROM THE COMPANIES' RESPECTIVE SERVERS OR, IN THE CASE OF GRACENOTE, CHANGE DATA CATEGORIES FOR ANY CAUSE THAT GRACENOTE DEEMS SUFFICIENT. NO WARRANTY IS MADE THAT EITHER GRACENOTE CONTENT OR THE GRACENOTE SOFTWARE OR GRACENOTE SERVERS ARE ERROR-FREE OR THAT THE FUNCTIONING OF THE GRACENOTE SOFTWARE OR GRACENOTE SERVERS WILL BE UNINTERRUPTED. GRACENOTE IS NOT OBLIGATED TO PROVIDE YOU WITH ANY ENHANCED OR ADDITIONAL DATA TYPES THAT GRACENOTE MAY CHOOSE TO PROVIDE IN THE FUTURE AND IS FREE TO DISCONTINUE ITS ONLINE SERVICES AT ANY TIME. GRACENOTE DISCLAIMS ALL

WARRANTIES EXPRESS OR IMPLIED, INCLUDING, BUT NOT LIMITED TO, IMPLIED WARRANTIES OF MERCHANTABILITY, FITNESS FOR A PARTICULAR PURPOSE, TITLE, AND NON-INFRINGEMENT. NEITHER GRACENOTE WARRANTS THE RESULTS THAT WILL BE OBTAINED BY YOUR USE OF THE GRACENOTE SOFTWARE OR ANY GRACENOTE SERVER. IN NO CASE WILL GRACENOTE BE LIABLE FOR ANY CONSEQUENTIAL OR INCIDENTAL DAMAGES OR FOR ANY LOST PROFITS OR LOST REVENUES FOR ANY REASON WHATSOEVER.

© Gracenote 2007.

FCC ID: KMHSYNGC2

IC: 1422A-SYNGC2

This device complies with Part 15 of the FCC Rules and with RSS-210 of Industry Canada. Operation is subject to the following two conditions: (1) This device may not cause harmful interference, and (2) this device must accept any interference received, including interference that may cause undesired operation.

WARNING



Changes or modifications not expressly approved by the party responsible for compliance could void the user's authority to operate the equipment. The term "IC" before the radio certification number only signifies that Industry Canada technical specifications were met.

The antenna used for this transmitter must not be co-located or operating in conjunction with any other antenna or transmitter.

Index

A

- A/C
 - See: Climate Control.....73
- About This Manual.....5
 - Protecting the Environment.....5
- ABS
 - See: Brakes.....109
- ABS driving hints
 - See: Hints on Driving With Anti-Lock Brakes.....109
- Accessories
 - See: Replacement Parts Recommendation.....8
- ACC
 - See: Using Adaptive Cruise Control.....119
- Adjusting the Steering Wheel.....41
- Air Conditioning
 - See: Climate Control.....73
- Air Vents.....73
 - Center Air Vents.....73
 - Side Air Vent.....73
- Alarm
 - See: Anti-Theft Alarm.....36
- All-Wheel Drive.....108
- Anti-Theft Alarm.....36
 - Alarm System.....36
 - Arming the Alarm.....37
 - Disarming the Alarm.....38
 - Guard Settings.....37
 - Triggering the Alarm.....37
- Appendices.....280
- Ashtray.....91
- At a Glance.....10
- Audible Warnings and Indicators.....61
 - Airbag Secondary Warning.....61
 - Auto-Start-Stop.....61
 - Door Ajar.....61
 - Emergency Door Open.....61
 - Exterior Lamps On.....61
 - Over Speed Warning.....61
 - Parking Brake On.....61
 - Safety Belt Minder.....61
- Audio Control.....41
 - Type 1.....41
 - Type 2.....42
- Audio Input Jack.....233
- Audio System.....207
 - General Information.....207
- Audio Troubleshooting.....234
- Audio unit.....208
 - Alternative Frequencies.....212
 - Bluetooth Audio Streaming.....215
 - Declaration of Conformity.....216
 - iPod.....215
 - Making and Receiving Calls.....214
 - News Broadcasts.....211
 - Phone.....212
 - Phone Menu Options.....214
 - Radio Button.....210
 - Regional Mode.....212
 - Set Button.....210
 - Station Preset Buttons.....210
 - Station Tuning Control.....210
 - Traffic Information Control.....211
 - USB.....215
- Audio unit - Vehicles With: AM/FM/CD.....217
 - Alternative Frequencies.....220
 - Automatic Volume Control.....220
 - Autostore Control.....219
 - News Broadcasts.....220
 - Radio Button.....218
 - Regional Mode.....221
 - Sound Button.....218
 - Station Preset Buttons.....219
 - Station Tuning Control.....219
 - Traffic Information Control.....219
- Audio unit - Vehicles With: SYNC/AM/FM/CD.....227
 - Alternative Frequencies.....231
 - Automatic Volume Control.....230
 - Autostore Control.....230
 - News Broadcasts.....231
 - Radio Button.....229
 - Regional Mode.....231
 - Sound Button.....229
 - Station Preset Buttons.....229
 - Station Tuning Control.....229
 - Traffic Information Control.....230

Index

Audio unit - Vehicles With: SYNC/ Navigation System.....	221	Catalytic Converter.....	101
Alternative Frequencies.....	226	Driving with a Catalytic Converter.....	101
Automatic Volume Control.....	225	Changing a Bulb.....	163
Autostore Control.....	224	Central High Mounted Brake Lamp.....	166
Digital Signal Processing.....	225	Front Fog Lamps.....	165
News Broadcasts.....	226	Headlamp.....	163
Radio Button.....	223	Interior Lamp.....	167
Regional Mode.....	226	License Plate Lamp.....	167
Sound Button.....	223	Reading Lamps.....	167
Station Preset Buttons.....	224	Rear Lamps.....	166
Station Tuning Control.....	224	Side Repeater.....	165
Traffic Information Control.....	224	Sun Visor Mirror Lamp.....	168
Autolamps.....	48	Changing a Fuse.....	151
Auto-Start-Stop.....	97	Changing a Road Wheel.....	184
ECO System.....	98	Front Jacking Points.....	186
To Restart the Engine.....	98	Installing a Road Wheel.....	188
To Stop the Engine.....	97	Locking Lug Nuts.....	184
Using Auto-Start-Stop.....	97	Rear Jacking Points.....	187
Autowipers.....	44	Removing a Road Wheel.....	188
Auxiliary Heater.....	77	Stowing the Wheel and Vehicle Jack.....	189
Fuel Operated Heater.....	80	Vehicle Jack.....	185
Fuel Operated Parking Heater.....	77	Vehicles with a Spare Wheel.....	184
Auxiliary Power Points.....	89	Changing the 12V Battery.....	159
AC Power Point.....	89	Installing the Battery.....	161
Auxiliary Power Point Locations.....	89	Removing the Battery.....	159
AWD		Changing the Wiper Blades.....	161
See: All-Wheel Drive.....	108	Changing the Rear Window Wiper Blade.....	162
B		Changing the Windshield Wiper Blades.....	161
Bonnet Lock		Checking the Wiper Blades.....	161
See: Opening and Closing the Hood.....	153	Child Safety.....	15
Bottle Holder.....	91	Child Safety Locks.....	23
Brake and Clutch Fluid Check.....	157	Left-Hand Side.....	23
Brakes.....	109	Right-Hand Side.....	23
General Information.....	109	Child Seat Positioning.....	19
Breaking-In.....	135	Cigar Lighter.....	90
Brakes and Clutch.....	135	Cleaning the Alloy Wheels.....	175
Engine.....	135	Cleaning the Exterior.....	174
Tires.....	135	Body Paintwork Preservation.....	174
Bulb Specification Chart.....	168	Cleaning the Chrome Trim.....	174
C		Cleaning the Headlamps.....	174
Capacities and Specifications.....	195	Cleaning the Rear Window.....	174
Car Wash		Cleaning the Interior.....	174
See: Cleaning the Exterior.....	174	Instrument Cluster Screens, LCD Screens and Radio Screens.....	175
		Rear Windows.....	175
		Safety Belts.....	174

Index

Climate Control.....	73	Economical Driving.....	135
Principle of Operation.....	73	Accessories.....	136
Clock.....	67	Anticipation.....	135
Type 1.....	67	Efficient Speed.....	136
Type 2.....	67	Electrical Systems.....	136
Cold Weather Precautions.....	136	Gear Shifting.....	135
Coolant Check		Tire Pressures.....	135
See: Engine Coolant Check.....	157	Electromagnetic compatibility.....	280
Cornering Lamps.....	51	Emergency Exit.....	138
Cruise Control.....	42	End User License Agreement.....	281
Principle of Operation.....	118	SYNC® End User License Agreement	
Cruise control		(EULA).....	281
See: Using Cruise Control.....	118	Engine Coolant Check.....	157
Cup Holders.....	91	Adding Engine Coolant.....	157
D		Engine Immobilizer	
Data Recording.....	7	See: Passive Anti-Theft System.....	36
Daytime Running Lamps.....	49	Engine Oil Check.....	156
Daytime Running Lamps.....	49	Adding Engine Oil.....	156
Diesel Particulate Filter.....	95	Engine Oil Dipstick.....	156
Regeneration.....	95	Event Data Recording	
Digital Radio.....	232	See: Data Recording.....	7
Direction Indicators.....	51	Exterior Mirrors.....	54
DPF		Fold-Away Exterior Mirrors.....	54
See: Diesel Particulate Filter.....	95	Power Exterior Mirrors.....	54
Draining the Fuel Filter Water Trap.....	158	Power Folding Mirrors.....	54
Driver Airbag.....	27	F	
Driver Alert.....	125	Fastening the Safety Belts.....	24
Principle of Operation.....	125	Using Safety Belts During Pregnancy.....	24
Using Driver Alert.....	126	First Aid Kit.....	138
Driving Aids.....	124	Flat Tire Inflation	
Driving Hints.....	135	See: Temporary Mobility Kit.....	176
Driving Through Water.....	136	Floor Mats.....	136
DRL		Fog Lamps - Front	
See: Daytime Running Lamps.....	49	See: Front Fog Lamps.....	50
E		Fog Lamps - Rear	
Eco Mode.....	128	See: Rear Fog Lamps.....	50
Resetting Eco Mode.....	129	Front Door Storage Compartment.....	93
Type 1.....	129	Front Exterior Overview.....	10
Type 2 and 3.....	129	Front Fog Lamps.....	50
		Fuel and Refueling.....	99
		Fuel Burning Heater	
		See: Auxiliary Heater.....	77
		Fuel Consumption Figures.....	206
		Fuel Consumption.....	106
		Calculating Fuel Economy.....	106
		Filling the Fuel Tank.....	106

Index

Fuel Quality.....	100
Long-Term Storage.....	100
Fuel Shutoff.....	138
Fuse Box Locations.....	141
Body Control Module Fuse Box.....	141
Engine Compartment Fuse Box.....	141
Passenger Compartment Fuse Box.....	141
Pre-fuse Box.....	141
Fuses.....	141
Fuse Specification Chart.....	142
Body Control Module Fuse Box.....	150
Engine Compartment Fuse Box.....	142
Passenger Compartment Fuse panel.....	145
Pre-fuse Box.....	148

G

Gauges.....	56
Engine Coolant Temperature Gauge.....	57
Fuel Gauge.....	57
Information Display.....	56
General Information on Radio Frequencies.....	30

H

Handbrake See: Parking Brake.....	110
Hazard Warning Flashers.....	138
Headlamp Exit Delay.....	49
Headlamp Leveling.....	50
Head Restraints.....	81
Adjusting the Head Restraint.....	82
Removing the Head Restraint.....	82
Heated Seats.....	88
Heated Windows and Mirrors.....	77
Heated Exterior Mirrors.....	77
Heated Rear Window.....	77
Heated Windshield.....	77
Heating See: Climate Control.....	73
Hill Start Assist.....	111
Switching the System On and Off.....	111
Using Hill Start Assist.....	111

Hints on Controlling the Interior Climate.....	75
Cooling the Interior Quickly.....	75
General Hints.....	75
Heating the Interior Quickly.....	75
Maximum Cooling Performance in Instrument Panel or Instrument Panel and Footwell Positions.....	76
Recommended Settings for Cooling.....	75
Recommended Settings for Heating.....	75
Side Window Defogging in Cold Weather.....	76
Vehicle Stationary for Extended Periods During Extreme High Ambient Temperatures.....	75
Hints on Driving With Anti-Lock Brakes.....	109
Hood Lock See: Opening and Closing the Hood.....	153

I

Ignition Switch.....	94
Information Display Control.....	43
Information Displays.....	62
General Information.....	62
Information Messages.....	68
Installing Child Seats.....	15
Attaching a Child Seat with a Support Leg.....	18
Attaching a Child Seat with Top Tethers.....	18
Booster Seats.....	16
Child Seats for Different Mass Groups.....	15
ISOFIX Anchor Points.....	17
Instrument Cluster.....	56
Instrument Lighting Dimmer.....	49
Instrument Panel Overview - LHD.....	12
Instrument Panel Overview - RHD.....	13
Interior Lamps.....	52
Courtesy Lamp.....	52
Entrance Lamps.....	52
Reading Lamps.....	52
Interior Mirror.....	54
Auto-Dimming Mirror.....	55
Introduction.....	5

Index

J

Jump Starting the Vehicle.....	138
To Connect the Booster Cables.....	139
To Start the Engine.....	139

K

Keys and Remote Controls.....	30
-------------------------------	----

L

Lane Keeping System.....	127
Lane Keeping Alert.....	127
Lighting Control.....	47
Headlamp Flasher.....	48
High Beams.....	48
Lighting Control Positions.....	47
Parking Lamps.....	47
Lighting.....	47
General Information.....	47
Load Carriers	
See: Roof Racks and Load Carriers.....	130
Load Carrying.....	130
General Information.....	130
Load Retaining Fixtures.....	130
Securing Cargo.....	131
Locking and Unlocking.....	31
Automatic Locking.....	33
Automatic Re-Locking.....	33
Automatic Unlocking.....	34
Configurable Unlocking.....	35
Double Locking.....	31
Locking.....	31
Locking and Unlocking Confirmation.....	31
Locking and Unlocking the Doors From	
Inside.....	32
One-Stage Unlocking.....	34
Opening and Closing the Sliding Door.....	32
Opening the Double Rear Doors.....	33
Rear Emergency Exit.....	35
Slam Locking.....	33
Two-Stage Unlocking.....	34
Unlocking.....	31
Zone Re-Locking.....	34
Locks.....	31
Lug Nuts	
See: Changing a Road Wheel.....	184

M

Maintenance.....	153
General Information.....	153
Manual Climate Control.....	74
Manual Seats.....	82
Adjusting the Armrest.....	83
Adjusting the Height of the Driver	
Seat.....	83
Adjusting the Lumbar Support.....	82
Moving the Seat Backward and	
Forward.....	82
Recline Adjustment.....	83
Seat Cushion Adjustment.....	83
Swivel Seat.....	83
Manual Transmission.....	107
Selecting Reverse Gear.....	107
Message Center	
See: Information Displays.....	62
Mirrors	
See: Heated Windows and Mirrors.....	77
See: Windows and Mirrors.....	53
Mobile Communications Equipment.....	8

N

Navigation.....	271
Hazard Spot Warning.....	279
Information.....	276
Loading Map Data.....	271
Menu Structure.....	272
Navigation Map Updates.....	279
Road Safety.....	271
Route Options.....	274
Setting a Route.....	272
Setting Your Navigation Preferences.....	276
Type Approvals.....	279

O

Oil Check	
See: Engine Oil Check.....	156
Opening and Closing the Hood.....	153
Closing the Hood.....	154
Opening the Hood.....	153
Overhead Console.....	91
Overhead Storage Compartments.....	91

Index

P

Parking Aid.....	114
Switching the Parking Aid System Off.....	116
Parking Aids.....	114
Principle of Operation.....	114
Parking Brake.....	110
Center Parking Brake.....	110
Outboard Parking Brake.....	110
Passenger Airbag.....	27
Switching the Passenger Airbag Off.....	28
Switching the Passenger Airbag On.....	28
Passive Anti-Theft System.....	36
Arming the Engine Immobilizer.....	36
Coded Keys.....	36
Disarming the Engine Immobilizer.....	36
Principle of Operation.....	36
PATS	
See: Passive Anti-Theft System.....	36
Personalized Settings.....	68
Measure Units.....	68
Switching Chimes Off.....	68
Power Door Locks	
See: Locking and Unlocking.....	31
Power Running Boards.....	39
Power Seats.....	84
Power Lumbar.....	86
Power Steering Fluid Check.....	158
Adding Power Steering Fluid.....	158
Power Windows.....	53
Bounce-Back.....	53
Driver Side One-Touch Down.....	53
Driver Side One-Touch Up.....	53

R

Rear Fog Lamps.....	50
Rear Passenger Climate Controls.....	76
Rear Quarter Windows.....	55
Rear Seats.....	86
Installing the Seats.....	87
Recline Adjustment.....	86
Removing Seats - M2 Bus Only.....	86
Rear View Camera.....	116
Switching the Rear View Camera Off.....	117
Switching the Rear View Camera On.....	116
Using the Display.....	116
Vehicles with Parking Aid.....	117

Rear View Camera	
See: Rear View Camera.....	116
Rear Window Wiper and Washers.....	46
Rear Window Washer.....	46
Rear Window Wiper.....	46
Reduced Engine Performance.....	135
Refueling.....	104
Remote Control.....	30
Removing a Headlamp.....	162
Repairing Minor Paint Damage.....	175
Replacement Parts	
Recommendation.....	8
Collision Repairs.....	8
Scheduled Maintenance and Mechanical Repairs.....	8
Warranty on Replacement Parts.....	8
Replacing a Lost Key or Remote Control.....	30
Roadside Emergencies.....	138
Roof Racks and Load Carriers.....	130
Running-In	
See: Breaking-In.....	135
Running Out of Fuel.....	100
Adding Fuel From a Portable Fuel Container.....	100
Filling a Portable Fuel Container.....	100

S

Safety Belt Height Adjustment.....	25
Front Safety Belt.....	25
Rear Safety Belt.....	25
Safety Belt Minder.....	26
Turning the Safety Belt Minder Off.....	26
Safety Belts.....	24
Safety Precautions.....	99
Seats.....	81
Security.....	36
Selective Catalytic Reduction System.....	102
Contaminated Diesel Exhaust Fluid or Inoperative Selective Catalytic Reduction System.....	103
Diesel Exhaust Fluid Guidelines.....	103
Diesel Exhaust Fluid Level.....	102
Side Airbags.....	29
Side Curtain Airbags.....	29
Sitting in the Correct Position.....	81

Index

Sliding Windows.....	55	Technical Specifications - RWD.....	171
Snow Chains		Capacities.....	171
See: Using Snow Chains.....	180	Specifications.....	171
Speed Control		Temporary Mobility Kit.....	176
See: Cruise Control.....	118	Checking the Tire Pressure.....	179
Speed Limiter.....	124	General Information.....	176
Engine Speed Limiter.....	124	Inflating the Tire.....	177
Vehicle Speed Limiter - Adjustable.....	124	Using the Temporary Mobility Kit.....	177
Vehicle Speed Limiter - Fixed.....	124	Tire Care.....	179
Stability Control.....	113	Tire Inflation When Punctured	
Principle of Operation.....	113	See: Temporary Mobility Kit.....	176
Starter Switch		Tire Pressure Monitoring System.....	180
See: Ignition Switch.....	94	Changing Tires With a Tire Pressure	
Starting a Diesel Engine.....	95	Monitoring System.....	181
Cold or Hot Engine.....	95	How Temperature Affects the Tire	
Failure to Start.....	95	Pressures.....	183
Starting and Stopping the Engine.....	94	Tire Pressure Monitoring System Reset	
General Information.....	94	Procedure.....	183
Steering Wheel Lock.....	94	Understanding the Tire Pressure Monitoring	
Steering Wheel.....	41	System.....	181
Stepwell Lamps.....	51	Tire Repair Kit	
Storage Compartments.....	91	See: Temporary Mobility Kit.....	176
Supplementary Restraints System.....	27	Tires	
Principle of Operation.....	27	See: Wheels and Tires.....	176
Switching Off the Engine.....	96	Towbar Dimensions.....	200
Vehicles With a Turbocharger.....	96	Double Chassis Cab.....	203
Symbols Glossary.....	5	Maximum Permissible Nose Weight All	
SYNC™ Applications and		Vehicles.....	200
Services.....	250	Single Chassis Cab.....	202
In the Event of a Crash.....	252	Van/Kombi/Bus.....	201
Switching Emergency Assistance On and		Towing a Trailer.....	132
Off.....	251	Trailer Lighting.....	132
SYNC Applink.....	253	When towing a trailer.....	132
SYNC Emergency Assistance.....	251	Towing Points.....	133
SYNC™.....	235	Front Towing Point.....	133
General Information.....	235	Rear Towing Point.....	133
SYNC™ Troubleshooting.....	263	Recovery Hook Location.....	133
T		Towing the Vehicle on Four	
Technical Specifications - AWD.....	172	Wheels.....	134
Capacities.....	172	Towing.....	132
Specifications.....	172	Traction Control.....	112
Technical Specifications		Principle of Operation.....	112
See: Capacities and Specifications.....	195	Trailer Sway Control.....	133
Technical Specifications - FWD.....	170	Transmission.....	107
Capacities.....	170	Transmission	
Specifications.....	170	See: Transmission.....	107

Index

Trip Computer.....	67
All Values.....	68
Average Fuel Consumption.....	67
Average Speed.....	67
Distance to Empty.....	67
Instantaneous Fuel Consumption.....	67
Outside Air Temperature.....	68
Resetting the Trip Computer.....	67
Trip Odometer.....	67
U	
Under Hood Overview - AWD/ RWD.....	155
Under Hood Overview - FWD.....	154
Under Seat Storage.....	92
Under Seat Storage Compartment.....	92
Under Seat Storage Guard.....	93
Unique Driving Characteristics.....	97
USB Port.....	234
Using Adaptive Cruise Control.....	119
Automatic Braking.....	120
Automatic Switch Off.....	122
Changing the Set Speed.....	121
Detection Beam Issues.....	120
Forward Alert Function.....	123
Setting a Speed.....	121
Setting the Vehicle Gap.....	121
Standby Mode.....	122
Switching the System Off.....	122
Switching the System On.....	121
Using the System.....	121
Using All-Wheel Drive.....	108
All-Wheel Drive Lock Mode.....	108
Automatic Mode.....	108
Using Cruise Control.....	118
Switching Cruise Control Off.....	119
Switching Cruise Control On.....	118
Using Power Running Boards.....	39
Deploy and Stow Automatically.....	39
Deploy and Stow Using the Information Display.....	40
Manual Operation.....	40
Resetting the System.....	40
Using Snow Chains.....	180
Vehicles with Stability Control.....	180
Using Stability Control.....	113
Switching the System Off and On Using the Information Display Controls.....	113
Switching the System Off Using a Switch.....	113
Using SYNC™ With Your Media Player.....	256
Accessing Your USB Song Library.....	262
Bluetooth Devices and System Settings.....	263
Connecting Your Media Player to the USB Port.....	257
Media Menu Features.....	261
Media Voice Commands.....	258
What's Playing?.....	258
Using SYNC™ With Your Phone.....	239
Accessing Features Through the Cell Phone Menu.....	244
Accessing Your Cell Phone Settings.....	247
Bluetooth Devices.....	248
Cell Phone Options During an Active Call.....	243
Cell Phone Voice Commands.....	240
Making a Call.....	242
Pairing a Cell Phone For the First Time.....	239
Pairing Subsequent Cell Phones.....	239
Receiving a Call.....	243
Text Messaging.....	245
Using Traction Control.....	112
Switching the System Off and On Using the Button.....	112
Switching the System Off and On Using the Information Display Controls.....	112
Using Voice Recognition.....	236
Helpful Hints.....	236
Initiating a Voice Session.....	237
System Interaction and Feedback.....	237
Using Winter Tires.....	180
V	
Vehicle Care.....	174
Vehicle Dimensions.....	195
Chassis Cab.....	196
Motorhome Chassis.....	199
Van/Kombi/Bus.....	195
Vehicle Identification Number.....	206

Index

Vehicle Identification Plate.....	204
Vehicle Interior Overview.....	11
Ventilation	
See: Climate Control.....	73
Vents	
See: Air Vents.....	73
VIN	
See: Vehicle Identification Number.....	206
Voice Control.....	42
W	
Warning Lamps and Indicators.....	57
All-Wheel Drive Lock Indicator.....	57
Anti-Lock Brake System Warning Lamp.....	57
Brake Pad Wear Warning Lamp.....	57
Brake System Warning Lamp.....	57
Collision Warning System Indicator.....	58
Direction Indicator.....	58
Door Ajar Warning Lamp.....	58
Engine Temperature Warning Lamp.....	58
Engine Warning Lamps.....	58
Exhaust Emission Fluid Warning Lamp.....	58
Front Airbag Warning Lamp.....	59
Front Fog Lamp Indicator.....	59
Frost Warning Lamp.....	59
Glow Plug Indicator.....	59
Headlamp Indicator.....	59
High Beam Indicator.....	59
Hill Start Assist Indicator.....	59
Ignition Warning Lamp.....	59
Lane Departure Warning Indicator.....	59
Low Fuel Level Warning Lamp.....	59
Low Tire Pressure Warning Indicator.....	60
Message Center Indicator.....	59
Oil Pressure Warning Lamp.....	60
Over Speed Warning Indicator.....	60
Rear Fog Lamp Indicator.....	60
Safety Belt Minder Warning Lamp.....	60
Shift Indicator.....	60
Stability Control Indicator.....	60
Stability Control Off.....	60
Start-Stop Indicator.....	60
Water In Fuel Indicator.....	61
Warning Triangle.....	138
Washer Fluid Check.....	158
Washers	
See: Cleaning the Exterior.....	174
See: Wipers and Washers.....	44
Wheel Nuts	
See: Changing a Road Wheel.....	184
Wheels and Tires.....	176
General Information.....	176
Technical Specifications.....	190
Windows and Mirrors.....	53
Windshield Washers.....	45
Windshield Wipers.....	44
Intermittent Wipe.....	44
Speed dependent wipers (if equipped).....	44
Winter Tires	
See: Using Winter Tires.....	180
Wipers and Washers.....	44

