



ABOUT THIS WRECKER TOWING MANUAL

Ford Motor Company salutes and applauds the towing industry for many fine years of service to the automotive industry. We will continue to work to provide our customers with guidelines.

This manual contains the latest towing procedures for 2012 Ford and Lincoln vehicles. Ford Motor Company has created easy-to-follow instructions with illustrations showing the correct hook-up for damage-free towing.

As an additional safety measure, be sure to use safety chains on every tow, including wheel lift and flatbed hook-ups. This procedure will prevent losing the vehicle in the event of equipment failure or vehicle breakage at the chain attachment.

New body effects and aerodynamic styling require new methods of towing; this is to eliminate the possibility of damage while in-tow. Wheel lifts or flatbed equipment is required to tow Ford Motor Company vehicles. Refer to the instructions given for the specific vehicle to be towed.

GENERAL TOWING INFORMATION

NOTE, NOTICE AND WARNING

As you read through this manual, you may come across a **NOTE, NOTICE** or **WARNING**. Each one is there for a specific purpose: A **NOTE** calls attention to unique, additional or essential information related to the subject procedure. A **NOTICE** identifies a hazard that could damage the vehicle or property. A **WARNING** identifies a hazard, to yourself or others, that could result in severe injury or death.

Preparatory Steps

NOTICE: Never use a tow bar that attaches to the fascia/bumper when towing a vehicle. The fascia/bumper could be damaged and/or cause an accident.

NOTICE: Incorrect towing of a vehicle may result in damage to the transmission/transaxle, transfer case, front or rear fascia, steering/suspension, exhaust, etc. Always follow the outlined towing procedures. It is recommended that only an unloaded vehicle be towed.

NOTICE: Always consult the tow equipment manufacturer, for specific instructions, on how to operate their equipment.

To prevent damage to the vehicle, it is the tow equipment operator's responsibility to evaluate and adjust to the specific towing conditions.

If a vehicle has been modified, consult the equipment modifier or supplier for the specific towing instruction.

NOTE: When towing a vehicle, the steering wheel should be left unlocked.

NOTE: Disabling the airbag system when towing an undamaged vehicle as instructed in this manual is not necessary. If the ignition is OFF, the bags will not deploy regardless of any impact during towing. An air bag is highly unlikely to deploy during towing. Standard towing or recovery procedures on an air bag equipped vehicle should not cause air bag deployment. However, when working with a vehicle that has been damaged, always proceed with caution around un-deployed airbags.

NOTE: When towing the vehicle, turn the ignition to the off position to deactivate the airbag system. Reference the Owner Guide "Starting and Stopping the Engine" chapter for Keyless Ignition System.

If the air bags are not deployed and as a precaution the air bag system needs to be disabled, disconnect the battery in a safe manner.

When towing a vehicle, release the parking brake and place the transmission/transaxle in NEUTRAL. As a general rule, vehicles should be towed with the drive wheels off the ground. If the vehicle is to be towed on its drive wheels, place the drive wheels on a dolly.

When a vehicle is towed on its front wheels, the steering wheel must be clamped in the straight-ahead position with a steering wheel clamping device designed for towing service use, such as those provided by towing system manufacturers.

Do not use the vehicle's steering column lock, when towing from either the front or rear, to lock the wheels in a straight-ahead position. If the steering wheel is not able to be unlocked, place a dolly underneath the drive wheels of the vehicle and tow with the non-drive wheels raised.

Brake-Shift Interlock

All Ford and Lincoln vehicles incorporate a brake-shift interlock feature that will prevent the gearshift lever from being moved from PARK when the ignition switch is in the ON position, however, when the brake pedal is depressed, the gearshift lever is unlocked and can then be moved. If you cannot move the gearshift lever out of PARK with the ignition in the ON position and the brake pedal depressed, refer to the automatic transmission/transaxle section in the driving section of the Owner's Literature Guide.

PowerShift 6-speed Automatic Shift to Neutral and Focus Electric (Fiesta and Focus)

NOTE: There must be 12 volt battery power to shift the transmission into neutral.

For vehicles with a key:

1. Step on the brake.
2. Turn the key to the on (II) position.
3. Shift the transmission to the neutral position.
4. Turn the ignition to the off position.

For vehicles with push button start:

1. With the brake not depressed, press the "Push-Button Start" button. This will turn the ignition on.
2. Depress the brake pedal.
3. Shift the vehicle to neutral.
4. Release the brake pedal.
5. Depress the "Push-Button Start" button to turn the ignition off.

On both ignitions, "Transmission Ready" will display in the message center.

Flat Bed

NOTICE: On vehicles equipped with an air suspension system, be sure the air suspension service switch is turned off prior to the vehicle being tied down.

NOTICE: Never hook a J-hook to any suspension or driveline component.

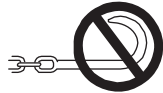

When using a flatbed to transport a vehicle, unless indicated otherwise, use a T-hook inserted in the appropriate tie-down slot. **Never hook a J-hook to any suspension, wheel or driveline component because damage to these components may occur.** When using winches, care must be taken to avoid damaging the fascia, bumper, lower body panels and/or air dams.

Wheel Lift

NOTICE: Check vehicle specifications for raised vehicle height requirements. If these height requirements are not followed, damage to the body and/or the underbody may occur.

NOTICE: When towing over roads that are rough or have crowned intersection, the following special procedures are required when using any wheel lift equipment. The vehicle must be secure to the wheel lift equipment using safety chains equipped with T-hooks or safety hooks. If this procedure is not followed, excessive jounce travel of the suspension may cause damage to the underbody.

1. Unless otherwise specified, attach the safety chain T-hooks in the appropriate slot of the body or frame of the vehicle being towed.
2. Run the chain through the hooks on the wheel lift crossbar and attach it to the towing vehicle.
3. Make sure there is no slack in the safety chain between the vehicle and the crossbar.
4. Repeat Steps 1 through 3 for the other side of the vehicle.

Slingbelts

Ford Motor Company does not recommend the use of slingbelt towing. Using slingbelt towing procedures may cause damage to the fascia, lower body panels, air dams and/or other components.

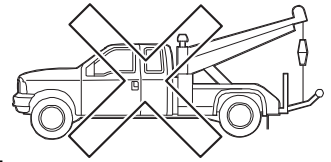

Towing Speeds and Distance

NOTE: If a distance of 50 mi (80 km) and/or a speed of 35 mph (55 km/h) is exceeded, or when the vehicle is towed with the drive wheels on the ground, position dollies under the wheels. Towing speed should not exceed 50 mph (80 km/h) when the vehicle is towed with the front wheels off the ground. Do not tow with both front and rear wheels on the ground.

NOTE: On rough pavement, the maximum towing speed is 35 mph (55 km/h). Maximum towing speed of 35 mph (55 km/h) should be used whenever the tow truck operator is not sure of road surface condition.

See specific model instructions for vehicle towing speed and distance limitations.

UNLTD = Unlimited miles, at speeds up to 50 mph (80 km/h).

Refer to the dolly manufacturer for speed and weight limitations.

Towing Four-Wheel Drive Vehicles with Lever-Operated Transfer Case – F-150, F-250 through F-550

1. Place an automatic transmission in PARK or manual transmission in 1st gear.
2. **NOTE:** The transfer case NEUTRAL setting is located between 4H and 4L. In order to place the transfer case in NEUTRAL, the lever must be moved slightly to the left and rearward of the 4H position. With the ignition in the ON position, both the 4x4 and LOW RANGE indicators will be OFF when the transfer case is in NEUTRAL. If the battery is dead, jump the vehicle to make sure the indicator lights are off.

Place the transfer case in N (NEUTRAL).

3. **NOTE:** To verify the hubs are in the FREE position or “unlocked”, check the front driveshaft, it should turn freely if the hubs are unlocked.

On an F-Super Duty, set and verify that the manual locking hubs are in the FREE position. Use dollies if the hubs do not unlock.

Towing speed should not exceed 50 mph (80 km/h). This applies with either the front or rear wheels off the ground.

Towing Four-Wheel Drive Vehicles with Electronic Shift Transfer Case – F-150, F-250 through F-550, and Ranger

1. **NOTE:** With the ignition in the ON position, both the 4x4 HI and the LOW RANGE indicators will be OFF when the transfer case is in 2 HI. If the battery is dead, jump the vehicle to make sure the indicator lights are off.
2. Place an automatic transmission in PARK or manual transmission in 1st gear.
3. **NOTE:** Manual locking hubs apply to F-250 through F-550 only.

Set the locking hubs to the AUTO position. Verify that the hubs are unlocked. Use dollies if the hubs do not unlock. Once these conditions are met, follow the instructions for towing a 2-wheel drive vehicle.

Damaged Vehicle Guidance for Ford Motor Company Electric and Hybrid-Electric Vehicles Equipped with High Voltage Batteries

(Towing and Recovery Operators and Vehicle Storage Facilities)

For questions contact Ford USA 1-800-392-3673
/ Ford Canada 1-800-565-3673

In the event of damage or fire involving an Electric Vehicle (EV) or Hybrid-Electric Vehicle (HEV):

- Always assume the high voltage (HV) battery and associated components are energized and fully charged.
- Exposed electrical components, wires and HV batteries present potential HV shock hazards.
- Venting/off-gassing HV battery vapors are potentially toxic and flammable.
- Physical damage to the vehicle or HV battery may result in immediate or delayed release of toxic and/or flammable gases and fire.

Vehicle Shutdown and High Voltage System Disabling

Identify Vehicle

- Determine if the vehicle is an electric or hybrid-electric vehicle, and if it is, advise your dispatch and all other responders that an electric or hybrid-electric vehicle is involved.
- To identify potential symptoms of a damaged high voltage system, contact an authorized service center or vehicle manufacturer representative. Refer to the Vehicle Owner Manual, Emergency Placard (included in the Vehicle Owner Manual) and/or the Emergency Response Guide for appropriate contact information.
- If you detect leaking fluids, sparks, smoke, flames, increased temperature, gurgling, popping or hissing noises from the HV battery compartment, ventilate the passenger area (i.e., roll down windows or open doors) and call 911.
- Be alert. There is a potential for delayed fire with damaged lithium-ion batteries.

Recovering/Transporting Vehicle

- Call an authorized service center or vehicle manufacturer representative, if necessary, to determine additional steps that you should take to safely recover or transport the vehicle.
- Always approach the vehicle from the sides to stay out of potential travel path. It may be

difficult to determine if the vehicle is running due to lack of engine noise.

- Place vehicle into Park, set the parking brake, turn off the vehicle, activate hazard lights, and remove keys to a distance at least 16 feet from the vehicle until loading the vehicle for transport.
- Refer to vehicle manual/recovery guide to locate proper attachment/connection points and transport method.
- Avoid contact with orange high voltage cabling and areas identified as high voltage risk by warning labels.

Storing Vehicle

- **For vehicles in the United States, notify Ford Motor Company 1-800-392-3673 (then follow the prompts on the voice response menu) or an authorized Ford Dealer as soon as possible as there may be additional steps necessary to secure, discharge, handle, and/or store the HV battery and vehicle.**
- **For vehicles in Canada, notify Ford Motor Company 1-800-565-3673 (then follow the prompts on the voice response menu), or an authorized Ford dealer as soon as possible as there may be additional steps necessary to secure, discharge, handle, and/or store the HV battery and vehicle.**
- Do not store a severely damaged vehicle with a lithium-ion battery inside a structure or within 50 feet of any structure or vehicle.
- Ensure that passenger and cargo compartments remain ventilated.
- Prior to placing and while located in storage area/tow lot, continue to inspect vehicle for leaking fluids, sparks, smoke, flames, gurgling or bubbling sounds from the HV battery and call 911 if any of these are detected.
- Maintain clear access to stored vehicles for monitoring and emergency response if needed.

For specific information and safety preparation regarding the high voltage system, refer to WWW.MOTORCRAFTSERVICE.COM, select quick guides for the appropriate vehicle emergency response guide.

NOTICE: Never attempt to tow the vehicle with its drive wheels on the ground.

WARNING: DAMAGED ELECTRIC VEHICLES SUBMERGED IN WATER PRESENT A POTENTIAL HIGH VOLTAGE ELECTRICAL SHOCK HAZARD. EXERCISE CAUTION AND WEAR APPROPRIATE PERSONAL PROTECTIVE EQUIPMENT (PPE) SAFETY GEAR, INCLUDING HIGH VOLTAGE SAFETY GLOVES AND BOOTS. REMOVE ALL METALLIC JEWELRY, INCLUDING WATCHES AND RINGS. DO NOT ATTEMPT TO EXTRACT THE VEHICLE UNTIL THE HIGH VOLTAGE BATTERY HAS DISCHARGED INDICATED BY THE ABSENCE OF BUBBLING OR FIZZING. FAILURE TO FOLLOW THESE INSTRUCTIONS MAY RESULT IN SERIOUS PERSONAL INJURY OR DEATH.

WARNING: FIRES IN CRASH-DAMAGED ELECTRIC VEHICLES MAY EMIT TOXIC OR COMBUSTIBLE GASSES. SMALL AMOUNTS OF EYE, SKIN OR LUNG IRRITANTS MAY BE PRESENT. WEAR PERSONAL PROTECTIVE EQUIPMENT (PPE) AND SELF-CONTAINED BREATHING APPARATUS WHEN WORKING IN CLOSE PROXIMITY OR IN A CONFINED AREA, SUCH AS A TUNNEL OR GARAGE. VENTILATE THE VEHICLE INTERIOR BY OPENING VEHICLE WINDOWS OR DOORS. VENTILATE THE WORKING AREA. FAILURE TO FOLLOW THIS INSTRUCTION MAY RESULT IN SERIOUS PERSONAL INJURY OR DEATH.

WARNING: ELECTRIC VEHICLES DAMAGED BY A CRASH MAY HAVE COMPROMISED HIGH VOLTAGE SAFETY SYSTEMS AND PRESENT A POTENTIAL HIGH VOLTAGE ELECTRICAL SHOCK HAZARD. EXERCISE CAUTION AND WEAR APPROPRIATE PERSONAL PROTECTIVE EQUIPMENT (PPE) SAFETY GEAR, INCLUDING HIGH VOLTAGE SAFETY GLOVES AND BOOTS. REMOVE ALL METALLIC JEWELRY, INCLUDING WATCHES AND RINGS. ISOLATE THE HV SYSTEM AS DIRECTED BY THE FORD EMERGENCY RESPONSE GUIDE FOR THE VEHICLE. FAILURE TO FOLLOW THESE INSTRUCTIONS MAY RESULT IN SERIOUS PERSONAL INJURY OR DEATH.

WARNING: ELECTRIC VEHICLES WITH DAMAGED HIGH VOLTAGE BATTERIES REQUIRE SPECIAL HANDLING PRECAUTIONS. INSPECT THE VEHICLE CAREFULLY FOR LEAKING BATTERY FLUIDS, SPARKS, FLAMES, AND GURGLING OR BUBBLING SOUNDS. CONTACT EMERGENCY SERVICES IMMEDIATELY IF ANY OF THESE PROBLEMS ARE OBSERVED. FAILURE TO FOLLOW THESE INSTRUCTIONS MAY RESULT IN A VEHICLE FIRE AND PERSONAL INJURY OR DEATH.

Focus Electric Battery and High Voltage Service Disconnect Locations

1. High Voltage Batteries.
2. High Voltage Service Disconnects.

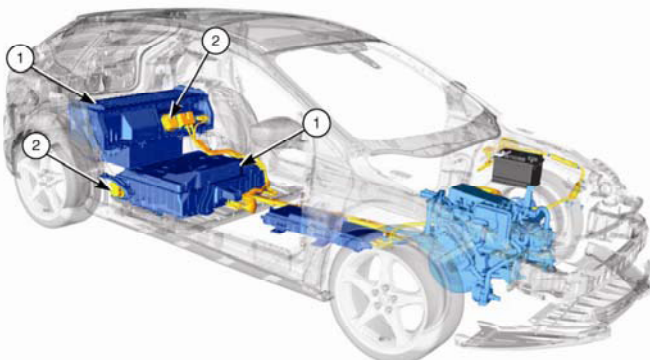

TOWING SPECIFICATION AND ILLUSTRATION TABLE

Vehicle	Warnings, Notices and Notes	Flatbed		Front and Rear Wheel Lift							
		Flat Bed	Tie Down	Wheel Lift Front	Wheel Lift Rear	Clearance Height — Front	Clearance Height — Rear	Towing from Front	mph – km/h miles - km	Towing from Rear	mph – km/h miles - km
CARS											
Fiesta	A,B,C,I,M,S	1	24	3	5	15 in	15 in	W/Dolly See 25	Unltd	W/Dolly See 25	Unltd
Focus (FWD)	A,B,C,H,I	1	12	3	5	18 in	18 in	W/Dolly See 25	Unltd	W/Dolly See 25	Unltd
Focus Electric	A,B,C,G,H,I,U,V, Y Æ,Y	1	13	3	5	16 in	16 in	W/Dolly See 25	Unltd	W/Dolly See 25	Unltd
Fusion/MKZ (AWD) Fusion/MKZ Hybrid (AWD)	A,B,C,D,E,I	1	22	3	5	19 in	19 in	W/Dolly	Unltd	W/Dolly	Unltd
Fusion/MKZ (FWD) Fusion/MKZ Hybrid (FWD)	A,B,C,E,I	1	22	2	5	19 in	19 in	W/O	Unltd	W/Dolly	Unltd
Fusion Sport (FWD)	A,B,C,E,I,M	1,6,8	22	2	5	19 in	19 in	W/O	Unltd	W/Dolly	Unltd
Taurus/MKS (AWD)	A,B,C,D,E,H,I,M	1	23	3	5	12 in	12 in	W/Dolly	Unltd	W/Dolly	Unltd
Taurus/MKS (FWD)	A,B,C,E,H,I,M	1	23	2	5	12 in	12 in	W/O	Unltd	W/Dolly	Unltd
Mustang (RWD) V6 and V8	A,B,C,D,I,K,L	1	13	3	5	16 in	14 in	W/Dolly	Unltd	W/Dolly	Unltd
Mustang Shelby GT 500 (RWD)	A,B,C,D,I,K,L,M,N	1,7,8,9	13	3	N/A	16 in	14 in	W/Dolly	Unltd	N/A	N/A
Mustang Boss With Side Exhaust (RWD)	A,B,C,D,I,K,L,M,N	1,7,8,9	13	3	N/A	16 in	14 in	W/Dolly	Unltd	N/A	N/A
TRUCKS											
E-Series, E-150/250/350/450	A,B,E,I,O,R	1	14	3	4	12 in	12 in	W/Dolly	Unltd	W/O	Unltd
Edge/MKX (AWD)	A,B,C,D,E,H,I	1	20	3	5	12 in	12 in	W/Dolly	Unltd	W/Dolly	Unltd
Edge/MKX (FWD)	A,B,C,D,E,H,I	1	20	2	5	12 in	12 in	W/O	Unltd	W/Dolly	Unltd
Escape/Escape Hybrid, (4WD)	A,B,C,D,I	1	15	3	5	12 in	12 in	W/Dolly	Unltd	W/Dolly	Unltd
Escape/Escape Hybrid, (FWD)	A,B,C,D,I	1	15	2	5	12 in	12 in	W/O	Unltd	W/Dolly	Unltd
Expedition/Navigator (4WD)	A,B,C,D,G,I,Q,R	1	18	3	5	12 in	12 in	W/Dolly	Unltd	W/Dolly	Unltd
Expedition/Navigator (RWD)	A,B,D,G,I,R	1	18	3	4	12 in	12 in	W/Dolly	* Unltd	W/O	Unltd
Explorer (AWD)	A,B,C,D,E,H,I,M	1	21	3	5	15 in	15 in	W/Dolly	Unltd	W/Dolly	Unltd
Explorer (FWD)	A,B,C,E,H,I,M	1	21	2	5	15 in	15 in	W/O	Unltd	W/Dolly	Unltd
F-150 (4WD)	A,B,C,D,G,I,Q,R	1	18	3	5	12 in	12 in	W/Dolly	Unltd	W/Dolly	Unltd
F-150 (RWD)	A,B,D,G,I,R	1	18	3	4	12 in	12 in	W/Dolly	* Unltd	W/O	Unltd
F-250/350/450/550 (4WD)	A,B,I,J,O,P,Q,R	1,10	16	3	5	12 in	12 in	W/Dolly	Unltd	** W/O	Unltd
F-250/350/450/550 (RWD)	A,B,J,I,O,R	1,10	16	3	4	12 in	12 in	W/Dolly	* Unltd	** W/O	Unltd
Flex/MKT (AWD)	A,B,C,D,E,H,I,M	1	21	3	5	15 in	15 in	W/Dolly	Unltd	W/Dolly	Unltd
Flex/MKT (FWD)	A,B,C,E,H,I,M	1	21	2	5	15 in	15 in	W/O	Unltd	W/Dolly	Unltd
Raptor	A,G,I,R	1	18	N/A	N/A	N/A	N/A	N/A	N/A	N/A	N/A
Transit Connect	A,B,C,H,I	1	11	2	5	12 in	12 in	W/O	Unltd	W/Dolly	Unltd

* In case of an emergency, the vehicle can be towed with the drive wheels on the ground up to a speed of 35 mph (55 km/h) and up to a distance of 50 mi (80 km).

** On a 4X2/4X4 vehicle in 2HI and the hubs in the AUTO/FREE position, it is acceptable to tow the vehicle with the front wheels on the ground (without dollies) and the rear wheels off the ground.

WARNINGS, NOTICES AND NOTES

(See page 6 for specific vehicle application)

A	<p>NOTICE: Ford Motor Company has not approved a slingbelt towing procedure. It is recommended that the vehicle be towed with a flatbed or wheel lift equipment. If the vehicle is towed by any other means or incorrectly, damage to the vehicle may occur.</p>
B	<p>NOTICE: If the vehicle is to be towed from the front or rear using wheel lift equipment, the lifted tire must be raised to a clearance height ABOVE the dollied tire to prevent damage to the vehicle undercarriage.</p> <p>The clearance height is the difference between the bottom of the tire lifted and the bottom of the dollied wheel. (See Illustration numbers 3 and/or 5.)</p>
C	<p>NOTICE: It is recommended that the vehicle (4WD, AWD, FWD and some RWD) be towed from the rear using wheel lift equipment. It is required that the front wheels be placed on a dolly to prevent damage to the vehicle fascia/bumper and/or the FWD, 4WD and AWD system.</p>
D	<p>NOTICE: It is recommended that the vehicle (4x2, 4WD, AWD, RWD and some FWD) be towed from the front using wheel lift equipment. It is required that the rear wheels be placed on a dolly to prevent damage to the vehicle fascia/bumper and/or the driveline system.</p>
E	<p>NOTICE: On a vehicle equipped with fog lamps or a sport package, care must be taken not to damage the components while loading and towing with a wheel lift or flatbed. For flatbed towing, wrap loading cable with a shop towel to protect fascia/bumper from damage.</p>
F	<p>WARNING: ON VEHICLES EQUIPPED WITH THE FIRE SUPPRESSION SYSTEM, COMPLETE ALL PRE-TOWING, UNDER-VEHICLE ACTIVITY (SECURING VEHICLE, CHAINS, STRAPS, ETC.) BEFORE TURNING THE KEY TO THE RUN POSITION. THE FIRE SUPPRESSION SYSTEM IS ACTIVE WHENEVER THE KEY IS IN THE RUN POSITION AND WILL DEPLOY IF THE MANUAL ACTIVATION BUTTON IS DEPRESSED.</p>
G	<p>NOTICE: On a vehicle equipped with an air suspension system, the system switch must be turned to the off position before the vehicle can be towed. Refer to the Owner's Literature for the procedure and switch location. If the rear air bags are deflated, load the vehicle on a flatbed and use a 4x4 board under the bed to lift the rear of the vehicle so that the rear bumper will not drag on the road</p>
H	<p>NOTICE: When a vehicle is towed over rough pitching roads, such as a crowned road intersection at a railroad crossing, towing speed should be greatly reduced to avoid damaging the vehicle undercarriage.</p>

I	<p>WARNING: DO NOT TOW A VEHICLE BACKWARD WHEN THE VEHICLE BEING TOWED HAS ALL 4 WHEELS ON THE GROUND.</p>
J	<p>NOTICE: When loading a vehicle on a flatbed, crossbeam/spacer blocks must be used to keep the cable from coming in contact with the chin spoiler. The crossbeam/spacer block can be held in place on the frame by using bungee cords.</p>
K	<p>NOTICE: Do not disconnect the driveshaft since the system is aligned and balanced. Connecting the driveshaft in the wrong position may cause vibration or damage to the driveline.</p>
L	<p>NOTICE: Manual transmission vehicles MUST have the parking brake fully engaged when the rear wheels are on the dolly. Failure to apply the parking brake may cause damage to the driveline.</p>
M	<p>NOTICE: To prevent damage to the bottom of the front or rear fascia/bumper covers, it is recommended that the vehicle be loaded onto a flatbed tow truck with the tow hook attached to a canvas strap. If the cable, chain or strap comes in contact with the fascia, wrap the tow cable, chain or strap with a shop towel.</p>
N	<p>NOTICE: When using a flatbed, it is recommended to use mini J-hooks to tie down the front of the vehicle. Larger J-hooks may cause damage to the undercarriage.</p>
O	<p>NOTE: For Dual Rear Wheel (DRW) vehicles, it may be necessary to remove the outer rear wheel when using wheel lift equipment.</p>
P	<p>NOTE: On a 4WD vehicle with Electronic Shift on the Fly (ESOF), it is recommended that the vehicle be towed with a wheel lift and dolly or flatbed equipment with all the wheels off the ground.</p>
Q	<p>NOTE: On a 4WD vehicle with Manual Shift on Stop (MSOS) and the lever operated transfer case positioned in NEUTRAL, it is acceptable to tow the vehicle with the rear wheels on the ground.</p>
R	<p>NOTE: For towing or operating conditions other than what is prescribed in this manual, the driveshaft must be removed. Always mark the location of the driveshaft to the attaching flange before removal so the shaft can be correctly indexed upon installation. Driveshaft attachment bolts should be replaced with new OEM bolts or have threadlocking compound added to the original bolts. Reinstall the driveshaft as instructed the workshop manual.</p>
S	<p>NOTICE: When wheel lifting from the rear, the front tires must be put on a dolly. Lift the rear wheels and secure with a safety strap. Pull the front tires onto 4x4 blocks using the stinger. Position the dollies to the smallest size opening. Secure the dollies with safety straps. Refer to Illustration 25.</p>

CONTINUED: WARNINGS, NOTICES AND NOTES

(See page 6 for specific vehicle application)

T **NOTICE:** For vehicles with side exhaust. For flatbed towing, secure the rear of the vehicle by using axle straps or lasso straps around the rear axle. One strap is required on each side of the differential. Using the standard T-slot attachment can damage the side exiting exhaust. Refer to Illustration 26.

U **WARNING:** ELECTRIC VEHICLES DAMAGED BY A CRASH MAY HAVE COMPROMISED HIGH VOLTAGE SAFETY SYSTEMS AND PRESENT A POTENTIAL HIGH VOLTAGE ELECTRICAL SHOCK HAZARD. EXERCISE CAUTION AND WEAR APPROPRIATE PERSONAL PROTECTIVE EQUIPMENT (PPE) SAFETY GEAR, INCLUDING HIGH VOLTAGE SAFETY GLOVES AND BOOTS. REMOVE ALL METALLIC JEWELRY, INCLUDING WATCHES AND RINGS. ISOLATE THE HV SYSTEM AS DIRECTED BY THE FORD EMERGENCY RESPONSE GUIDE FOR THE VEHICLE. FAILURE TO FOLLOW THESE INSTRUCTIONS MAY RESULT IN SERIOUS PERSONAL INJURY OR DEATH.

V **WARNING:** DAMAGED ELECTRIC VEHICLES SUBMERGED IN WATER PRESENT A POTENTIAL HIGH VOLTAGE ELECTRICAL SHOCK HAZARD. EXERCISE CAUTION AND WEAR APPROPRIATE PERSONAL PROTECTIVE EQUIPMENT (PPE) SAFETY GEAR, INCLUDING HIGH VOLTAGE SAFETY GLOVES AND BOOTS. REMOVE ALL METALLIC JEWELRY, INCLUDING WATCHES AND RINGS. DO NOT ATTEMPT TO EXTRACT THE VEHICLE UNTIL THE HIGH VOLTAGE BATTERY HAS DISCHARGED INDICATED BY THE ABSENCE OF BUBBLING OR FIZZING. FAILURE TO FOLLOW THESE INSTRUCTIONS MAY RESULT IN SERIOUS PERSONAL INJURY OR DEATH.

W **WARNING:** ELECTRIC VEHICLES WITH DAMAGED HIGH VOLTAGE BATTERIES REQUIRE SPECIAL HANDLING PRECAUTIONS. INSPECT THE VEHICLE CAREFULLY FOR LEAKING BATTERY FLUIDS, SPARKS, FLAMES, AND GURGLING OR BUBBLING SOUNDS. CONTACT EMERGENCY SERVICES IMMEDIATELY IF ANY OF THESE PROBLEMS ARE OBSERVED. FAILURE TO FOLLOW THESE INSTRUCTIONS MAY RESULT IN A VEHICLE FIRE AND PERSONAL INJURY OR DEATH.

X **NOTICE:** Never attempt to tow the vehicle with its drive wheels on the ground.

Y **WARNING:** FIRES IN CRASH-DAMAGED ELECTRIC VEHICLES MAY EMIT TOXIC OR COMBUSTIBLE GASSES. SMALL AMOUNTS OF EYE, SKIN OR LUNG IRRITANTS MAY BE PRESENT. WEAR PERSONAL PROTECTIVE EQUIPMENT (PPE) AND SELF-CONTAINED BREATHING APPARATUS WHEN WORKING IN CLOSE PROXIMITY OR IN A CONFINED AREA, SUCH AS A TUNNEL OR GARAGE. VENTILATE THE VEHICLE INTERIOR BY OPENING VEHICLE WINDOWS OR DOORS. VENTILATE THE WORKING AREA. FAILURE TO FOLLOW THIS INSTRUCTION MAY RESULT IN SERIOUS PERSONAL INJURY OR DEATH.

ILLUSTRATIONS

1

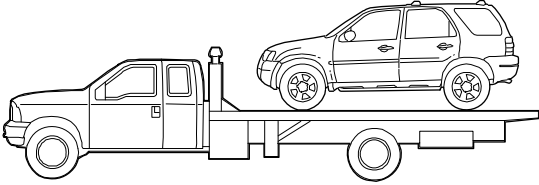

2

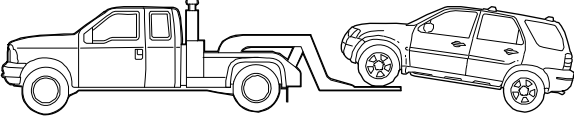

3

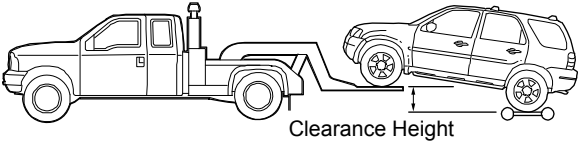

Clearance Height

4

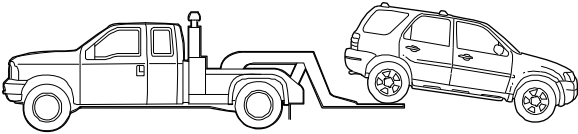

5

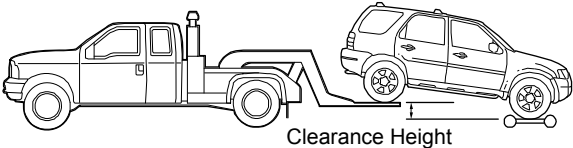

Clearance Height

6

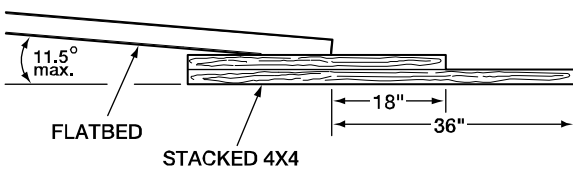

11.5° max.

FLATBED

STACKED 4X4

18"

36"

7

CROSSBEAM/WITHOUT SPACER BLOCKS

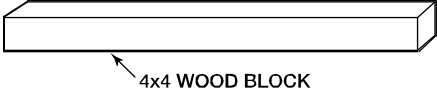

4x4 WOOD BLOCK

MATERIAL - CROSSBEAMS
2 - 4x4x60" LONG 2 - 4x4x48" LONG

8

V STRAP-FORGED CLUSTER HOOKS

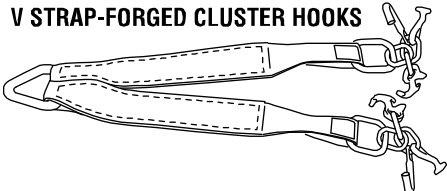

9 **LOADING**

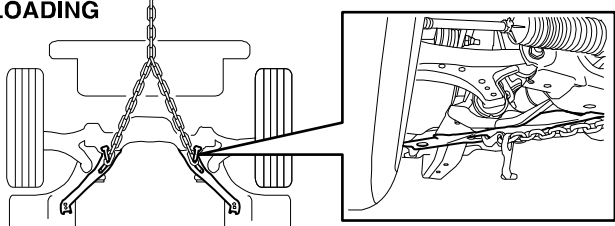

SHELBY GT500

TOW LINE

11.5° max.

FLATBED

STACKED 4X4

18"

36"

10

CROSSBEAM/SPACER BLOCKS

MATERIAL - CROSSBEAMS
ONE 4x4x60" LONG - ONE 4x4x48" LONG
for F-Super Duty

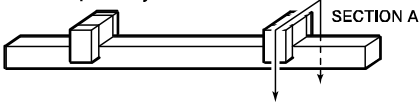

SECTION A

SPACER BLOCKS CAN BE FABRICATED AS SHOWN.

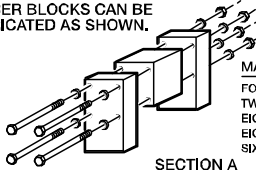

MATERIAL-SPACER BLOCKS
FOUR - 2x4x6" LONG
TWO - 2x4x3-1/2" LONG
EIGHT - 1/4x7" CARRIAGE BOLT
EIGHT - 1/4" NUT
SIXTEEN - 1/4" WASHER

SECTION A

Safety Chain Location Codes

T = Tie Down T-Slot **FT** = Flatbed/Rollback T-Slot

W = Wrap Chain **FW** = Flatbed/Rollback Winch Location

11

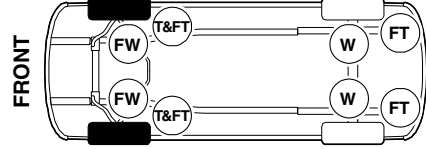

FRONT

FW T&FT

FW T&FT

W FT

W FT

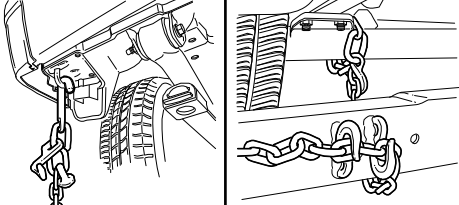

Use FT tie-downs for flatbed only.

Wrap rear axle for safety chains on wheel lift.

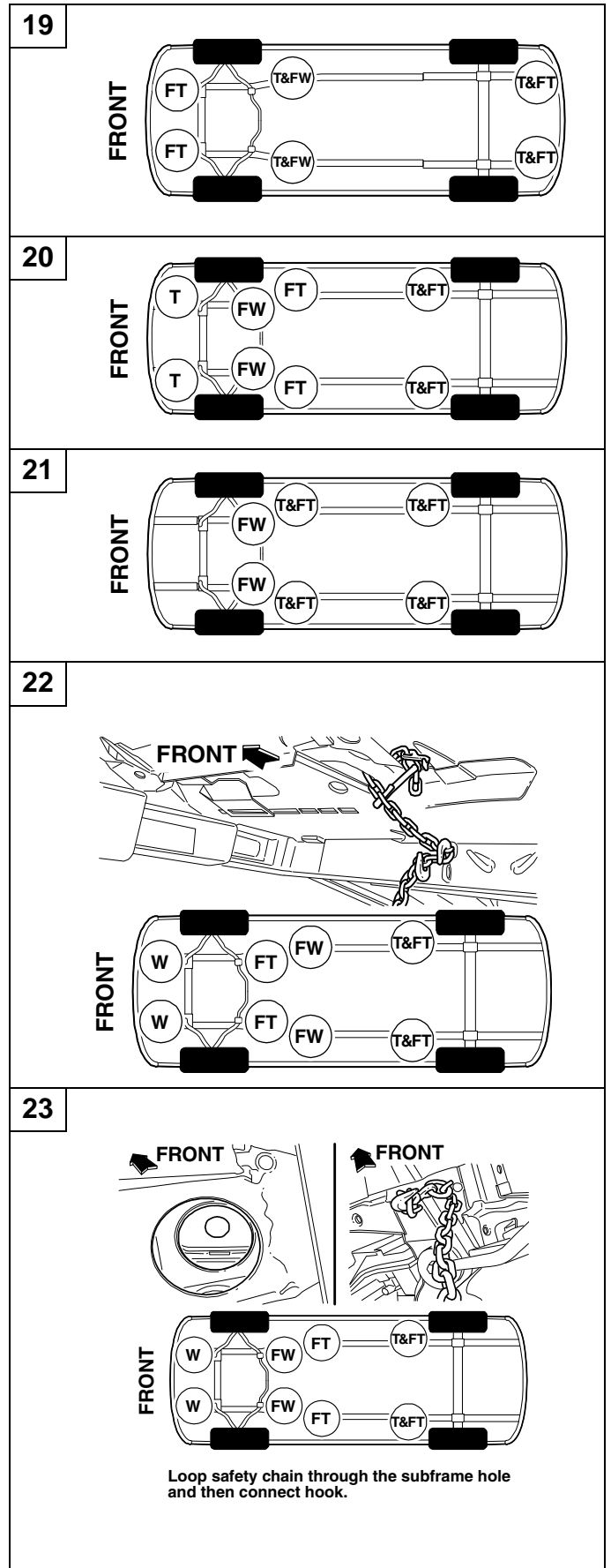
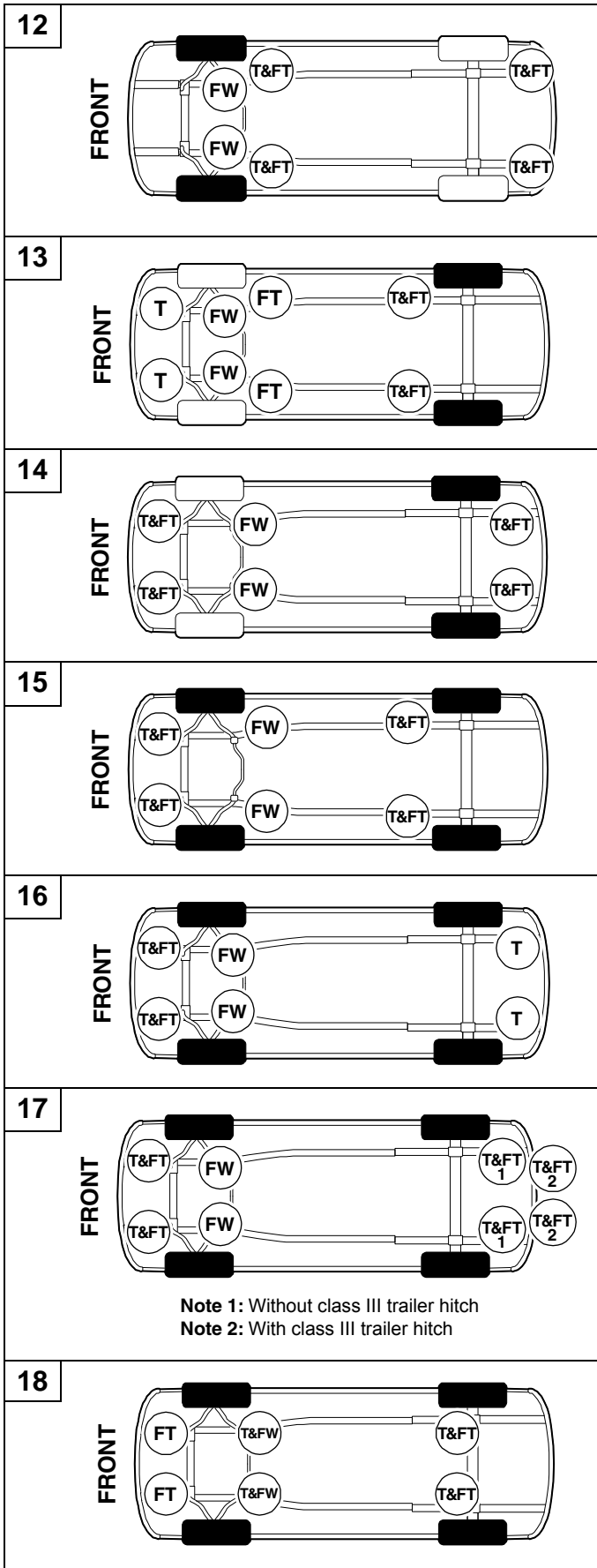

24

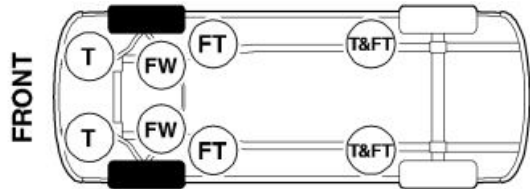

25

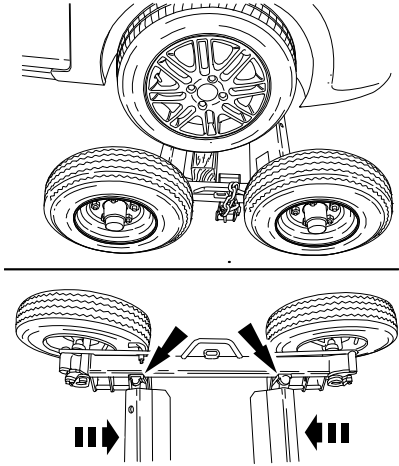

26

