

## ABOUT THIS MANUAL

Ford Motor Company salutes the towing industry and applauds you for your many fine years of service to the automotive industry. We will continue to work with you to provide our customers and yours with guidelines.

This manual contains the latest towing procedures for 2005 Ford, Lincoln and Mercury passenger cars and light trucks. As you turn the pages of this book, you will find the instructions easy to follow with clear illustrations showing the correct hook-up for damage-free towing.

As an additional safety measure, be sure you use safety chains on every tow, including wheel lift and flatbed hook-ups. This will prevent you from losing the vehicle in the event of equipment failure or vehicle breakage at the tow chain attachment.

New materials and aerodynamic styling require new methods of towing to eliminate the possibility of vehicle towing damage. Wheel lifts and flatbed equipment are required to tow many vehicles. Refer to the instructions given for the specific vehicle you are towing.

# FOREWORD

**This manual contains information and procedures for towing Ford Motor Company passenger cars and light trucks using slingbelt wrecker equipment.**

**CAUTION: To help avoid personal injury and/or vehicle damage, carefully follow procedures in this manual.**

**NOTE: Due to the many variations of wheel lift and flatbed equipment, instructions for their usage are not included in this manual. Refer to the instruction manuals supplied with wheel lift and flatbed equipment.**

# TABLE OF CONTENTS

	Page
Foreword .....	2
<b>TOWING EQUIPMENT .....</b>	<b>4</b>
<b>GENERAL TOWING INFORMATION — PASSENGER CARS .....</b>	<b>5-6</b>
<b>WRECKER TOWING FORD VEHICLES WITH AIR BAGS .....</b>	<b>7</b>
<b>PASSENGER CAR TOWING</b>	
Taurus, Sable .....	8-9
GT .....	10
Hydrogen Fuel Cell Focus .....	11
Focus .....	12-13
Town Car, Crown Victoria, Grand Marquis, Marauder .....	14-15
Mustang .....	16-17
Lincoln LS .....	18-19
Thunderbird .....	20-21
Five Hundred, Montego .....	22-23
<b>GENERAL TOWING INFORMATION — LIGHT TRUCKS .....</b>	<b>25-28</b>
<b>WRECKER TOWING FORD VEHICLES WITH AIR BAGS .....</b>	<b>29</b>
<b>LIGHT TRUCK TOWING</b>	
Freestyle .....	30-31
Freestar, Monterey .....	32
Aviator, Explorer, Mountaineer .....	33-34
Sport-Trac .....	35-36
Ranger .....	37-38
F-150, Navigator, Expedition, Mark LT .....	39-40
Harley Davidson, F-Super Duty (F-250, F-350, F-450, F-550) .....	41-42
Excursion .....	43-44
Escape, Escape Hybrid .....	45-46
E-Series, Club Wagon, E-150, E-250, E-350, E-450 .....	47-48
<b>2005 FORD SERVICE INFORMATION .....</b>	<b>49</b>

# TOWING EQUIPMENT

## SLINGBELT

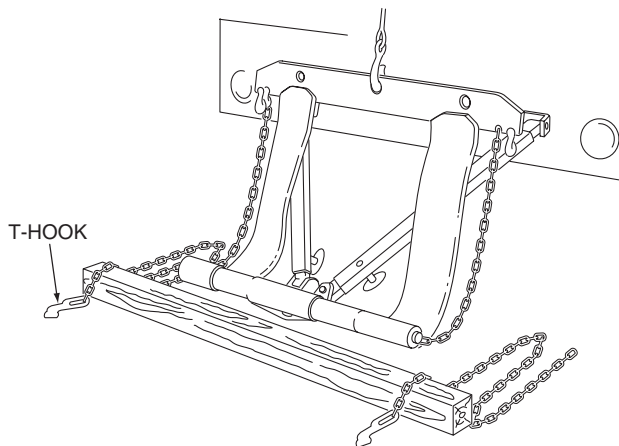

## CROSSBEAM/SPACER BLOCKS

MATERIAL – CROSSBEAMS

ONE – 4x4x60" LONG – ONE 4x4x48" LONG

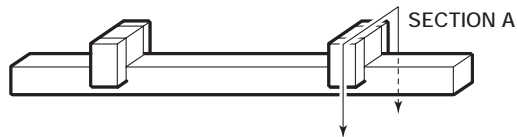

SPACER BLOCKS CAN BE  
FABRICATED AS SHOWN.

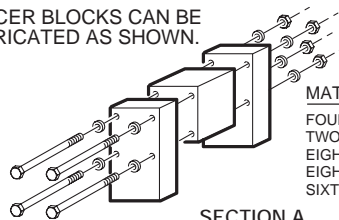

MATERIAL-SPACER BLOCKS

FOUR – 2x4x6" LONG

TWO – 2x4x3-1/2" LONG

EIGHT – 1/4x7" CARRIAGE BOLT

EIGHT – 1/4" NUT

SIXTEEN – 1/4" WASHER

SECTION A

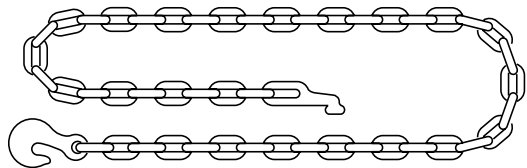

## CROSSBEAM/WITHOUT SPACER BLOCKS

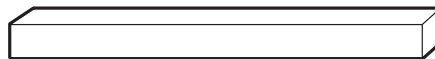

4x4 WOOD BLOCK

MATERIAL – CROSSBEAMS

2 – 4x4x60" LONG    2 – 4x4x48" LONG

# GENERAL TOWING INFORMATION — PASSENGER CARS

## IMPORTANT SAFETY NOTICE

### NOTES AND CAUTIONS

**As you read through the procedures, you will come across NOTES and CAUTIONS. Each one is there for a specific purpose. NOTES give you added information that will help to complete a particular procedure. CAUTIONS are given to prevent you from making an error that could damage the vehicle.**

### Preparatory Steps

Release the parking brake (see Lincoln LS for Electronic Parking Brake release procedure), and place transmission/transaxle in NEUTRAL. As a general rule, vehicles should be towed with the drive wheels off the ground. If the vehicle is to be towed on its drive wheels, the transmission/transaxle and differential must be operable. If the transmission/transaxle is not operable, place the drive wheels on a dolly or disconnect the rear driveshaft on rear wheel drive vehicles. **DO NOT** disconnect the driveshaft on Lincoln LS, Thunderbird or Mustang; refer to the caution in Lincoln LS, Thunderbird or Mustang portion of this manual. If the differential is not operable, place the drive wheels on a dolly.

When a vehicle is towed on its front wheels, the steering wheel must be clamped in the straight ahead position with a steering wheel clamping device designed for towing service use, such as those provided by towing system manufacturers.

Do not use the vehicle's steering column lock to lock the wheels in a straight ahead position when towed from the front or rear. If the ignition key is not available, place a dolly underneath the driving wheels of the vehicle and tow with the non-drive wheels raised.

### Brake-Shift Interlock

All Ford, Lincoln and Mercury vehicles, equipped with an automatic transmission/transaxle, incorporate a brake-shift interlock feature that prevents the gearshift lever from being moved from PARK when the ignition is in the ON position, unless the brake pedal is depressed. If you cannot move the gearshift lever out of PARK with the ignition in the ON position and the brake pedal depressed, refer to the automatic transmission or transaxle section in the driving section of the applicable Owner Guide.

### Flatbeds

When using a flatbed to transport a vehicle, always use T-hooks inserted in the appropriate tie down slot. Never fasten J-hooks to any suspension wheel or driveline component because J-hooks will damage these components. When using winches, take care to avoid damaging the bumper system, lower body panels or air dams.

On vehicles equipped with an air suspension system, be sure the air suspension service switch is turned off prior to vehicle tie down.

**CAUTION: Improperly tying down a disabled vehicle may damage the vehicle's suspension, driveline or body parts.**

### Wheel Lift

**CAUTION: When towing over very rough or crowned intersection roads, the following special procedures are required when using any wheel lift equipment. The vehicle must be secured to the wheel lift equipment using safety chains equipped with T-hooks. If these procedures are not followed, damage to the underbody may result from excessive jounce travel of the suspension.**

# GENERAL TOWING INFORMATION — PASSENGER CARS

1. Attach the safety chain T-hooks in the appropriate slot of the body or frame of the vehicle to be towed.
2. Run the chain through the hooks on the wheel lift crossbar and attach it to the towing vehicle.
3. For all vehicles except the Five Hundred and Montego, make sure that there is no slack in the safety chain between the vehicle to be towed and the crossbar.
4. Repeat steps 1 and 2 for the other side of the vehicle.

**NOTE:** Check vehicles specifications for raised vehicle height requirements.

## **Slingbelts**

Slingbelts may only be used when indicated in the towing procedure for a specific vehicle. When attaching slingbelts, take care to avoid damage to the license plate, fog lamps, etc., if equipped. Using a slingbelt when not indicated may cause damage to the bumper system, lower body panels or air dams.

## **Towing Speeds**

See specific model instructions for vehicle towing speed and distance limitations.

UNLTD = Unlimited speed (50 mph/80 km/h) or mileage.

**On rough pavement, the maximum towing speed is 35 mph (56 km/h). Maximum towing speed of 35 mph (56 km/h) should be used whenever the tow truck operator is not sure of road surface condition.**

**Refer to the dolly manufacturer for speed and weight limitations.**

# WRECKER TOWING FORD VEHICLES WITH AIR BAGS

## General Information

An air bag is highly unlikely to deploy during wrecker towing. Standard wrecker towing or recovery procedures on an air bag equipped vehicle should not cause air bag deployment. Only a significant frontal or side (if equipped with side air bags) impact that closes two crash sensors will deploy an air bag.

## How to Determine if a Ford Vehicle has Air Bags

- The fourth position of all Ford passenger car VINs is the letter:
  - “F” if equipped with active belts at all designated seating positions plus driver and passenger air bags.
  - “H” if equipped with active belts at all designated seating positions, driver and passenger air bags, plus driver and passenger side air bags, curtains, or canopies.
  - “B” if equipped with active belts at all designated seating positions less driver and passenger air bags – valid for F/CMVSS 500 low-speed vehicles only.
- The steering wheel hub will also be larger and more rectangular (about 6 in x 9 in). The passenger-side air bag module trim covers will be molded with “SRS” or “AIRBAG”.

- The VIN plate may have “AIR BAG” printed on it.

## Is it Necessary to Disable the Air Bag System for Wrecker Towing?

- Disabling the air bag system is **not** necessary in most cases. But, as a precaution, disconnect the battery ground (-) cable in a safe manner when the vehicle has significant damage to the front of the vehicle and an undeployed air bag.

**NOTE:** Turning the ignition switch to OFF may **not** disable the Ford air bag system. Some older model air bag deployment systems operate independently of the ignition key position.

## Wrecker Towing a Vehicle with Deployed Air Bags

- Deployed air bags are **not** dangerous.
- Any powdery residue consists of corn starch or talcum powder and sodium compounds, mostly sodium carbonates (e.g., baking soda) accompanied by very minute deposits of sodium hydroxide that can be irritating to the skin and eyes but poses no long term health hazard.

# TAURUS, SABLE

## FRONT TOWING CONNECTIONS

**CAUTION:** Use care not to damage fog lamps on vehicles, if equipped.



**CAUTION:** It is recommended that the Taurus, Sable be towed with a wheel lift or flatbed equipment. Do not tow with a slingbelt. Ford Motor Company has not approved a slingbelt towing procedure. If the vehicle is towed by other means or incorrectly, vehicle damage may occur.

**NOTE:** Refer to general towing information on pages 5 and 6 before towing vehicle.

TRANS	MPH/KMH	MILES/KMS
AUTO	UNLTD	UNLTD

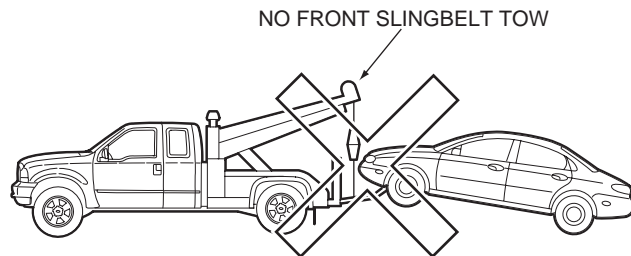
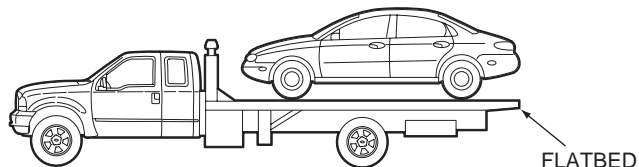
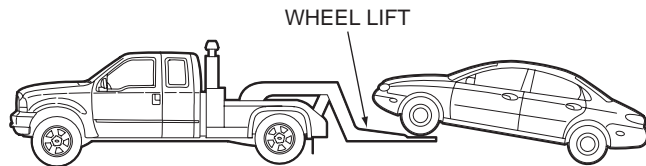



TRANS	MPH/KMH	MILES/KMS
AUTO without Dolly	35/56	50/80
AUTO with Dolly	UNLTD	UNLTD

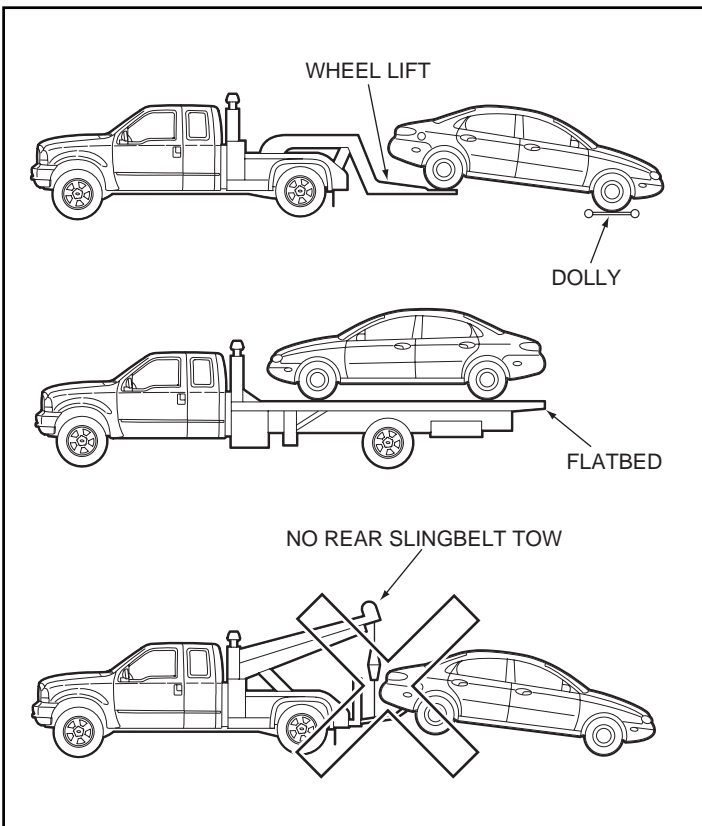

## TAURUS, SABLE

### REAR TOWING CONNECTIONS

**CAUTION:** If the Taurus, Sable is to be towed from the rear using wheel lift equipment, it is recommended that the front wheels (drive wheels) be placed on a dolly to prevent damage to the transaxle.



**CAUTION:** Do not use shipping slots on bumper brackets for towing.

**CAUTION:** It is recommended that the Taurus, Sable be towed with a wheel lift or flatbed equipment. Do not tow with a slingbelt. Ford Motor Company has not approved a slingbelt towing procedure. If the vehicle is towed by other means or incorrectly, vehicle damage may occur.

**NOTE:** Refer to general towing information on pages 5 and 6 before towing vehicle.

# GT

## TOWING CONNECTION

### Flatbed Towing Only

**CAUTION:** Do not attempt to tow this vehicle from the rear. Ford Motor Company has not approved towing this vehicle from the rear.



**CAUTION:** It is recommended that the GT be towed with flatbed equipment only. Do not tow with a slingbelt or wheel lift. Ford Motor Company has not approved a slingbelt or wheel lift towing procedure. If the vehicle is towed by other means or incorrectly, vehicle damage may occur.

The GT tow hook is stored inside the tire inflation kit in the front compartment.

### Flatbed Towing Procedure

1. Install the tow hook.
2. Stack one long and one short 4x4 wood block per side (used to extend the ramp length).
3. Lower wrecker deck to hold ramps in place.  
Upper 4x4 should extend 36 in (91 cm) behind the wrecker ramp.  
Lower 4x4 should extend 60 in (152 cm) behind the wrecker ramp.
4. Use the supplied tow hook on the front of the vehicle.
5. Transport the vehicle with the parking brake OFF and the transmission in NEUTRAL.
6. Secure the vehicle with wheel basket tie-downs to the wrecker deck.

**NOTE:** Inspect tie-downs periodically for tightness.

**NOTE:** Refer to general towing information on pages 5 and 6 before towing vehicle.

TRANS	MPH/KMH	MILES/KMS
MANUAL	UNLTD	UNLTD

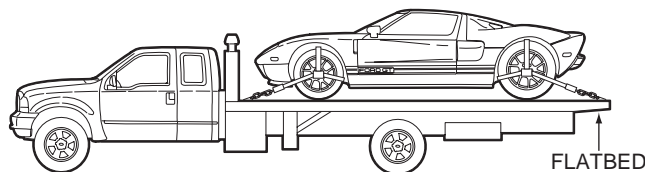
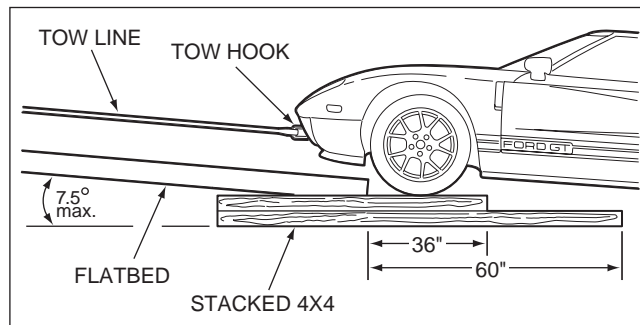
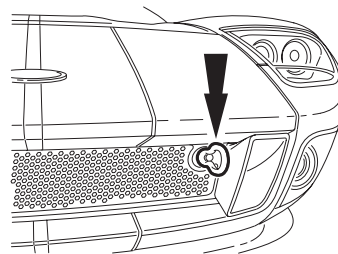

TRANS	MPH/KMH	MILES/KMS
AUTO	UNLTD	UNLTD
MANUAL	UNLTD	UNLTD

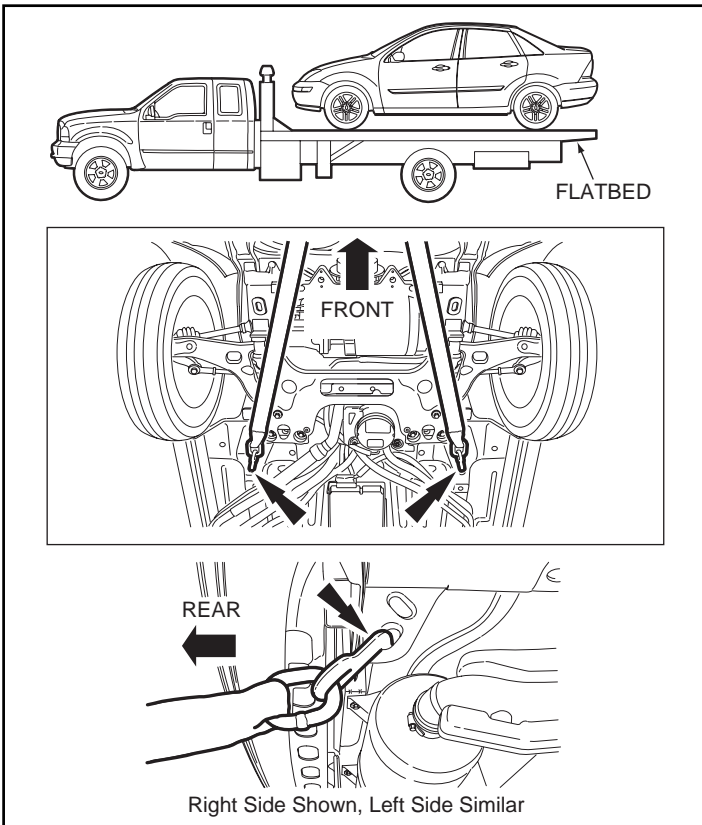

## Hydrogen Fuel Cell Focus

### FRONT AND REAR TOWING CONNECTIONS

**CAUTION:** The Hydrogen Fuel Cell Focus must be towed with flatbed equipment. Do not tow with a slingbelt. Ford Motor Company has not approved a slingbelt or wheel lift towing procedure. 

If the vehicle is towed from the front by other means or incorrectly, vehicle damage may occur.

**CAUTION:** Use supplied towing strap located in the trunk, in only the locations indicated. Failure to use the tow strap in the indicated locations, may cause vehicle damage.

**CAUTION:** When using the tow strap from the rear, it is essential to install the tow hooks from the outside. Failure to follow this procedure will cause damage to the rear fascia.

**CAUTION:** If the brake-shift interlock is not deactivated, the tires cannot roll. If you cannot move the gearshift lever from P (Park) with the brake pedal depressed, proceed as follows:

1. Turn the ignition off and remove the ignition key.
2. Apply the parking brake and the brake pedal.
3. Insert a screwdriver or similar tool about 2 in (5 cm) into the square opening to the right of the gearshift, at the base of the console.
4. Rotate the screwdriver point rearward.
5. Push and hold the thumb button and move the gearshift.
6. Remove the screwdriver when the gearshift moves from the P (Park) position.

The console-mounted gearshift will lock when you turn the key to the lock position. When the gearshift is in any position except P (Park), the ignition key cannot be removed from the steering column. To remove the key, the gearshift lever must be in P (Park).

**NOTE:** Refer to general towing information on pages 5 and 6 before towing vehicle.

## FOCUS

### FRONT TOWING CONNECTIONS

**CAUTION:** It is recommended that the Focus be towed with a wheel lift or flatbed equipment. Do not tow with a slingbelt. Ford Motor Company has not approved a slingbelt towing procedure. If the vehicle is towed from the front by other means or incorrectly, vehicle damage may occur.



**CAUTION:** If the brake-shift interlock is not deactivated, the tires cannot roll. If you cannot move the gearshift lever from P (Park) with the brake pedal depressed, proceed as follows:

1. Turn the ignition off and remove the ignition key.
2. Apply the parking brake and the brake pedal.
3. Insert a screwdriver or similar tool about 2 in (5 cm) into the square opening to the right of the gearshift, at the base of the console.
4. Rotate the screwdriver point rearward.
5. Push and hold the thumb button and move the gearshift.
6. Remove the screwdriver when the gearshift moves from the P (Park) position.

The console-mounted gearshift will lock when you turn the key to the lock position. When the gearshift is in any position except P (Park), the ignition key cannot be removed from the steering column. To remove the key, the gearshift lever must be in P (Park).

**NOTE:** Refer to general towing information on pages 5 and 6 before towing vehicle.

TRANS	MPH/KMH	MILES/KMS
AUTO	UNLTD	UNLTD
MANUAL	UNLTD	UNLTD

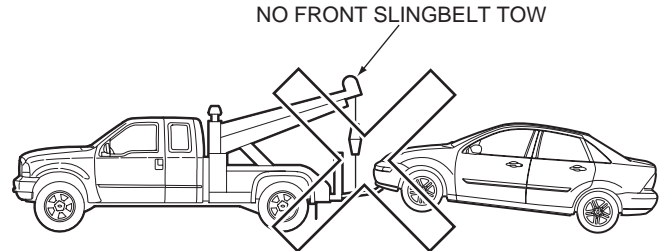
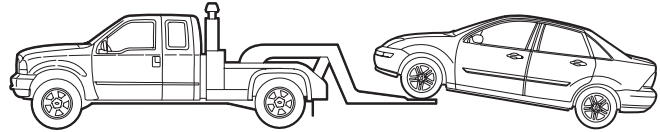
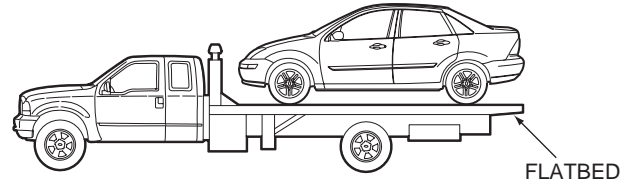

TRANS	MPH/KMH	MILES/KMS
AUTO	UNLTD	UNLTD
MANUAL	UNLTD	UNLTD

## FOCUS

### REAR TOWING CONNECTIONS

**CAUTION:** If the vehicle is to be towed from the rear using wheel lift equipment, the front wheels (drive wheels) must be placed on a dolly to prevent damage to the transaxle.



**CAUTION:** It is recommended that the Focus be towed with a wheel lift or flatbed equipment. Do not tow with a slingbelt. Ford Motor Company has not approved a slingbelt towing procedure. If the vehicle is towed by other means or incorrectly, vehicle damage may occur.

**NOTE:** Refer to general towing information on pages 5 and 6 before towing vehicle.

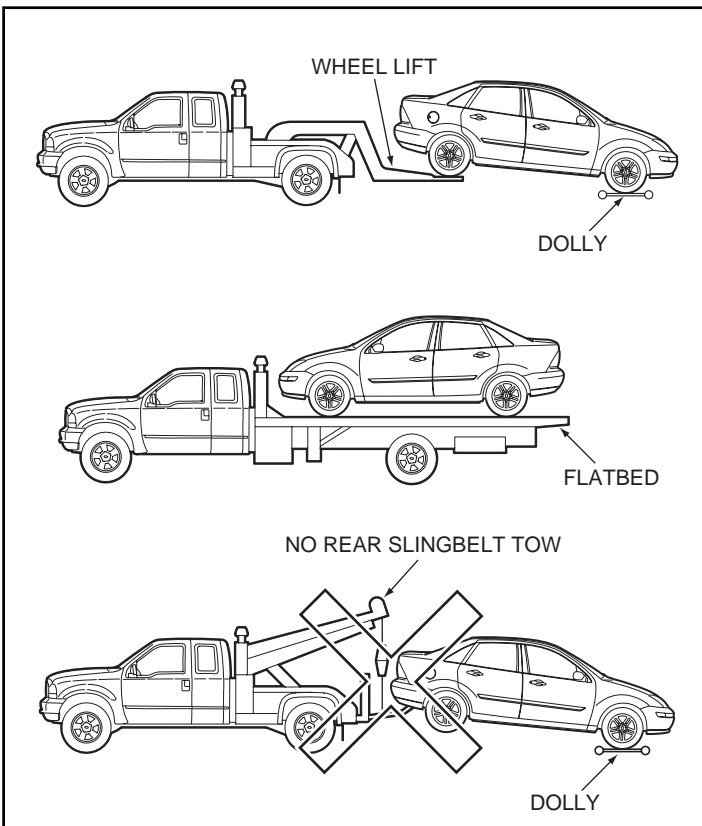

**TOWN CAR, CROWN VICTORIA, GRAND MARQUIS, MARAUDER**

**FRONT TOWING CONNECTIONS**

**WARNING:** On vehicles equipped with the Fire Suppression System, complete all pre-towing, under-vehicle activity (securing vehicle, chains, straps, etc.) before turning the key to the RUN position. The Fire Suppression System is active whenever the key is in the RUN position and will deploy if the manual activation button is depressed.



**CAUTION:** Before the vehicle can be towed, the air suspension control in the luggage compartment must be turned to the OFF position (if equipped).

**CAUTION:** It is recommended that the Town Car, Crown Victoria, Grand Marquis and Marauder be towed with a wheel lift or flatbed equipment. Do not tow with a slingbelt. Ford Motor Company has not approved a slingbelt towing procedure. If the vehicle is towed by other means or incorrectly, vehicle damage may occur.

**CAUTION:** On vehicles with air suspension – if the rear air bags are deflated, load the vehicle on a flatbed and use a 4x4 board under the bed to lift the rear of the vehicle so that the rear bumper will not drag on the road surface. (Refer to GT for example).

**NOTE:** Refer to general towing information on pages 5 and 6 before towing vehicle.

TRANS	MPH/KMH	MILES/KMS
AUTO	35/56	50/80

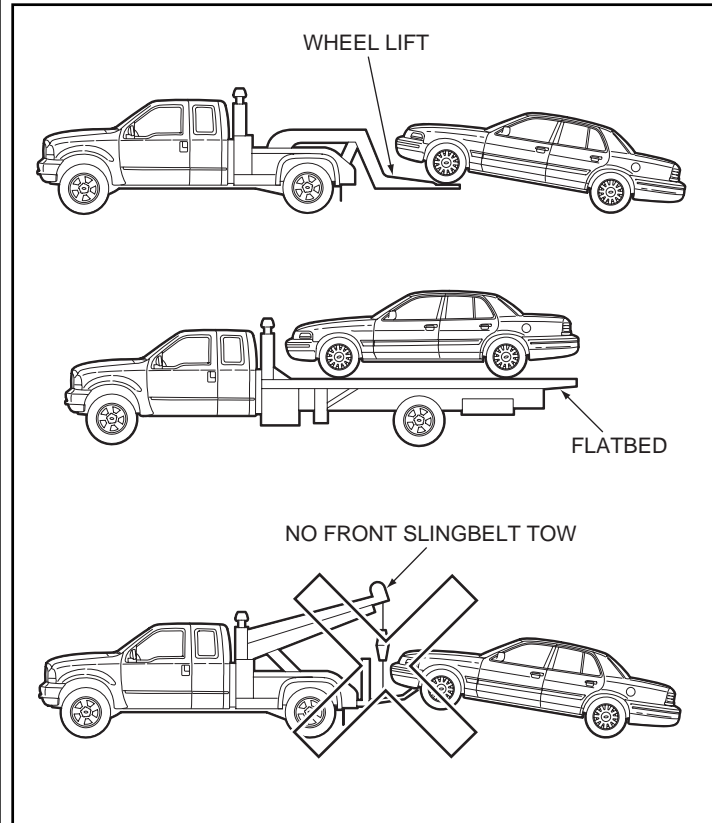

TRANS	MPH/KMH	MILES/KMS
AUTO	UNLTD	UNLTD

**TOWN CAR, CROWN VICTORIA, GRAND MARQUIS, MARAUDER**

**REAR TOWING CONNECTIONS**

**WARNING:** On vehicles equipped with the Fire Suppression System, complete all pre-towing, under-vehicle activity (securing vehicle, chains, straps, etc.) before turning the key to the RUN position. The Fire Suppression System is active whenever the key is in the RUN position and will deploy if the manual activation button is depressed.



**CAUTION:** Before the vehicle can be towed, the air suspension control in the luggage compartment must be turned to the OFF position (if equipped).

**CAUTION:** It is recommended that the Town Car, Crown Victoria, Grand Marquis and Marauder be towed with a wheel lift or flatbed equipment. Do not tow with a slingbelt. Ford Motor Company has not approved a slingbelt towing procedure. If the vehicle is towed by other means or incorrectly, vehicle damage may occur.

**CAUTION:** On vehicles with air suspension – if the rear air bags are deflated, load the vehicle on a flatbed and use a 4x4 board under the bed to lift the rear of the vehicle so that the rear bumper will not drag on the road surface. (Refer to GT for example.)

**NOTE:** Refer to general towing information on pages 5 and 6 before towing vehicle.

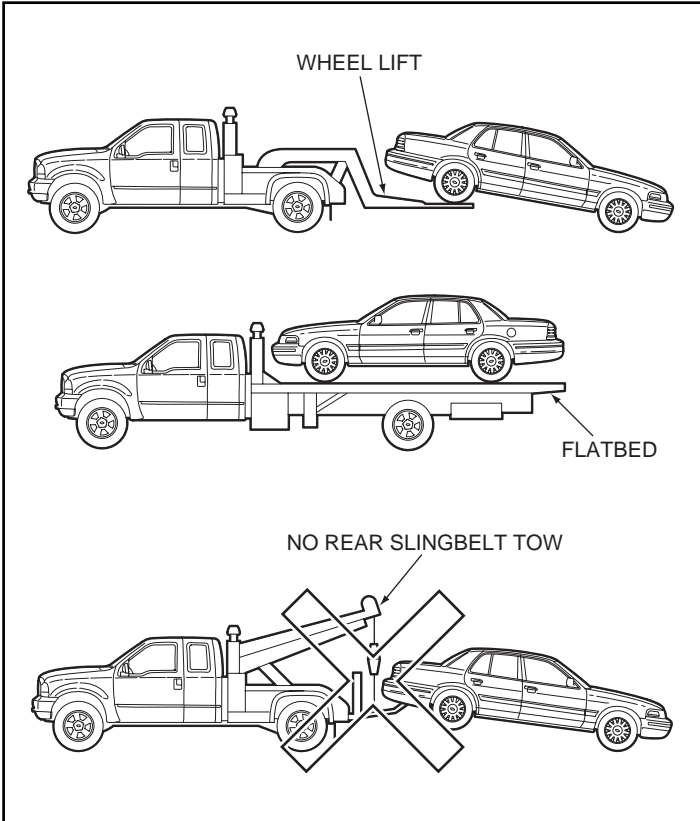

# MUSTANG

## FRONT TOWING CONNECTIONS

**CAUTION:** Do not disconnect the driveshaft since the system is aligned and balanced.

### V6 COUPE AND CONVERTIBLE WHEEL LIFT TOWING

**CAUTION:** If the Mustang is to be towed from the front using wheel lift equipment, the front wheels must be raised to a minimum height of 18 in (46 cm) ABOVE the non-raised wheels to prevent damage to the vehicle undercarriage.

**CAUTION:** Manual transmission vehicles **MUST** have the parking brake fully engaged.

### V8 COUPE AND CONVERTIBLE WHEEL LIFT TOWING

**CAUTION:** If the Mustang is to be towed from the front using wheel lift equipment, the front wheels must be raised to a minimum height of 16 in (41 cm) ABOVE the non-raised wheels to prevent damage to the vehicle undercarriage.

**CAUTION:** Manual transmission vehicles **MUST** have the parking brake fully engaged.

**CAUTION:** If the vehicle is towed from the front without using tow dollies for the rear tires, damage to the rear fascia may occur.

**CAUTION:** It is recommended that the Mustang be towed with wheel lift or flatbed equipment only. Do not tow with a slingbelt. Ford Motor Company has not approved a slingbelt towing procedure. If the vehicle is towed by other means or incorrectly, vehicle damage may occur.

**CAUTION:** It is recommended that the vehicle be loaded onto a flatbed tow truck with the tow hook attached to a canvas strap, to prevent damage to the bottom of the front or rear bumper covers. If a strap is not available, wrap the tow cable/chain with a cloth.

**NOTE:** Position the "L" arm as tight to the wheel as possible.

**NOTE:** Refer to general towing information on pages 5 and 6 before towing vehicle.

TRANS	MPH/KMH	MILES/KMS
AUTO	UNLTD	UNLTD
MANUAL	UNLTD	UNLTD

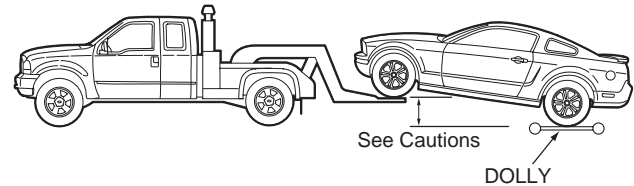
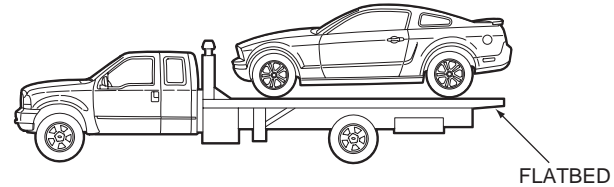

NO FRONT SLINGBELT TOW

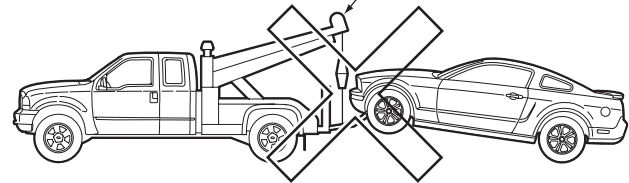



TRANS	MPH/KMH	MILES/KMS
AUTO	UNLTD	UNLTD
MANUAL	UNLTD	UNLTD

# MUSTANG

## REAR TOWING CONNECTIONS

**CAUTION:** Do not disconnect the driveshaft since the system is aligned and balanced.

**CAUTION:** If the Mustang is to be towed from the rear using wheel lift equipment, the rear wheels must be raised to a minimum height of 14 in (36 cm) ABOVE the non-raised wheels to prevent damage to the vehicle undercarriage.



**CAUTION:** If the vehicle is towed from the rear without using tow dollies for the front tires, damage to the front fascia may occur.

**CAUTION:** It is recommended that the vehicle be loaded onto a flatbed tow truck with the tow hook attached to a canvas strap, to prevent damage to the bottom of the front or rear bumper covers. If a strap is not available, wrap the tow cable/chain with a cloth.

**NOTE:** Position the L arm as tight to the wheel as possible.

**NOTE:** Safety chain T-hook slot is located inward of the rear tires.

**NOTE:** Refer to general towing information on pages 5 and 6 before towing vehicle.

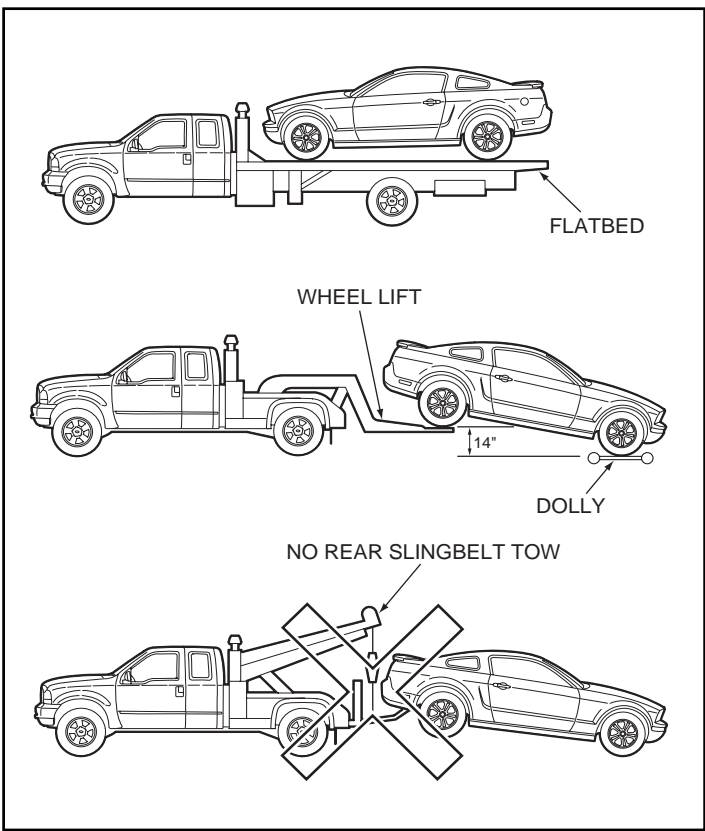

# LINCOLN LS

## FRONT TOWING CONNECTIONS

**CAUTION:** Do not disconnect the driveshaft since the system is aligned and balanced.



**CAUTION:** It is recommended that the Lincoln LS be towed with a wheel lift or flatbed equipment. Do not tow with a slingbelt. Ford Motor Company has not approved a slingbelt towing procedure. If the vehicle is towed by other means or incorrectly, vehicle damage may occur.

**CAUTION:** It is recommended that the vehicle be loaded onto a flatbed tow truck with the tow hook attached to a canvas strap, to prevent damage to the bottom of the front or rear bumper covers. If a strap is not available, wrap the tow cable/chain with a cloth.

**NOTE:** Refer to general towing information on pages 5 and 6 before towing vehicle.

### LS Electronic Parking Brake

To release the Electronic Parking Brake (EPB) on the vehicle with no battery power, perform the following steps.

1. Connect jumper cables as normal (battery access is in the trunk).
2. Turn the ignition key to the ON position.
3. Depress and hold the brake pedal, and then shift the transmission out of PARK.
  - The EPB will be released, but the system will need to be recalibrated. This procedure can be performed once the vehicle reaches its destination.

To release the EPB on a vehicle with battery power, perform the following steps.

1. Turn the ignition key to the ON position.
2. Depress and hold the brake pedal.
3. Push the EPB switch down.

TRANS	MPH/KMH	MILES/KMS
AUTO without Dolly	35/56	50/80
AUTO with Dolly	UNLTD	UNLTD

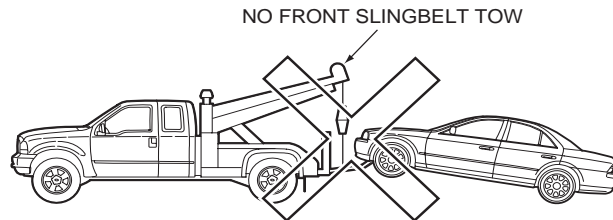
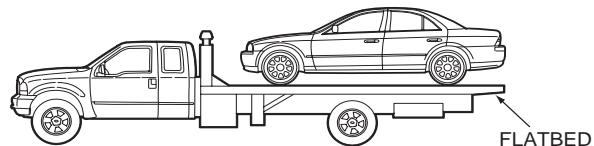
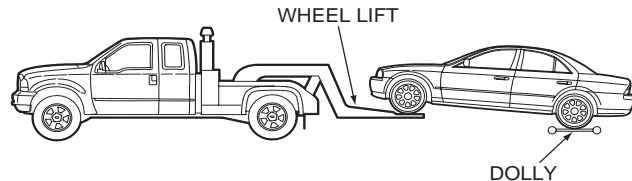

TRANS

MPH/KMH

MILES/KMS

AUTO

UNLTD

UNLTD

**LINCOLN LS****REAR TOWING CONNECTIONS**

**CAUTION:** Do not disconnect the driveshaft since the system is aligned and balanced.



**CAUTION:** It is recommended that the Lincoln LS be towed with a wheel lift or flatbed equipment. Do not tow with a slingbelt. Ford Motor Company has not approved a slingbelt towing procedure. If the vehicle is towed by other means or incorrectly, vehicle damage may occur.

**CAUTION:** It is recommended that the vehicle be loaded onto a flatbed tow truck with the tow hook attached to a canvas strap, to prevent damage to the bottom of the front or rear bumper covers. If a strap is not available, wrap the tow cable/chain with a cloth.

**NOTE:** Refer to general towing information on pages 5 and 6 before towing vehicle.

**LS Electronic Parking Brake**

To release the Electronic Parking Brake (EPB) on the vehicle with no battery power, perform the following steps.

1. Connect jumper cables as normal (battery access is in the trunk).
2. Turn the ignition key to the ON position.
3. Depress and hold the brake pedal, and then shift the transmission out of PARK.
  - The EPB will be released, but the system will need to be recalibrated. This procedure can be performed once the vehicle reaches its destination.

To release the EPB on a vehicle with battery power, perform the following steps.

1. Turn the ignition key to the ON position.
2. Depress and hold the brake pedal.
3. Push the EPB switch down.

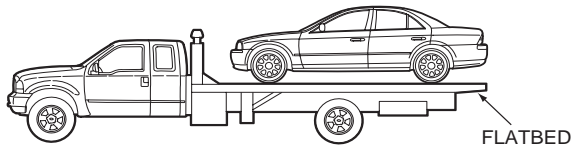
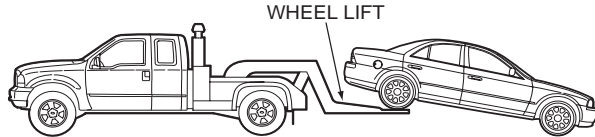

NO REAR SLINGBELT TOW

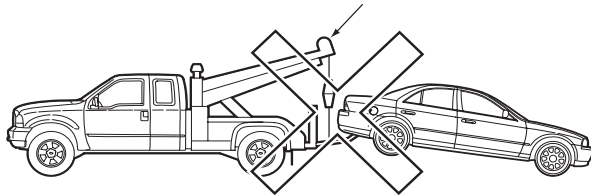

# THUNDERBIRD

## FRONT TOWING CONNECTIONS

**CAUTION:** Do not disconnect the driveshaft since the system is aligned and balanced.



**CAUTION:** It is recommended that the Thunderbird be towed with a wheel lift or flatbed equipment. Do not tow with a slingbelt. Ford Motor Company has not approved a slingbelt towing procedure. If the vehicle is towed by other means or incorrectly, vehicle damage may occur.

**CAUTION:** It is recommended that the vehicle be pulled onto a flatbed tow truck with the tow hook attached to a canvas strap, to prevent damage to the bottom of the front or rear bumper covers. If a strap is not available, wrap the tow cable/chain with a cloth.

**NOTE:** Refer to general towing information on pages 5 and 6 before towing vehicle.

TRANS	MPH/KMH	MILES/KMS
AUTO without Dolly	35/56	50/80
AUTO with Dolly	UNLTD	UNLTD

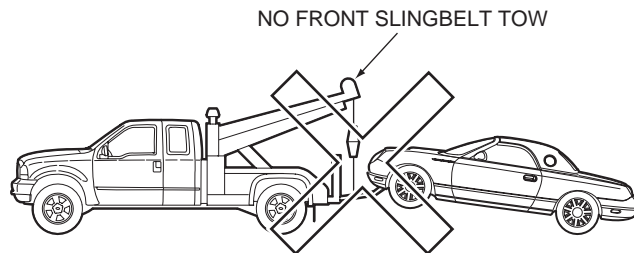
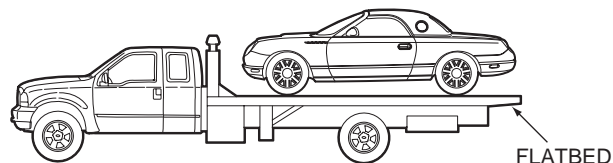
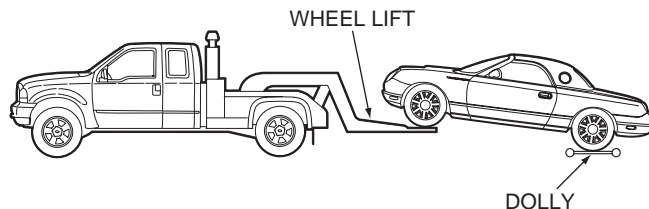

TRANS	MPH/KMH	MILES/KMS
AUTO	UNLTD	UNLTD

## THUNDERBIRD

### REAR TOWING CONNECTIONS

**CAUTION:** Do not disconnect the driveshaft since the system is aligned and balanced.



**CAUTION:** It is recommended that the Thunderbird be towed with a wheel lift or flatbed equipment. Do not tow with a slingbelt. Ford Motor Company has not approved a slingbelt towing procedure. If the vehicle is towed by other means or incorrectly, vehicle damage may occur.

**CAUTION:** It is recommended that the vehicle be pulled onto a flatbed tow truck with the tow hook attached to a canvas strap, to prevent damage to the bottom of the front or rear bumper covers. If a strap is not available, wrap the tow cable/chain with a cloth.

**NOTE:** Refer to general towing information on pages 5 and 6 before towing vehicle.

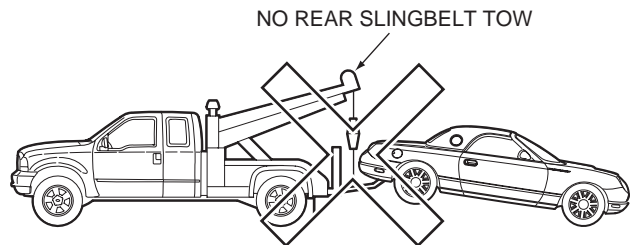
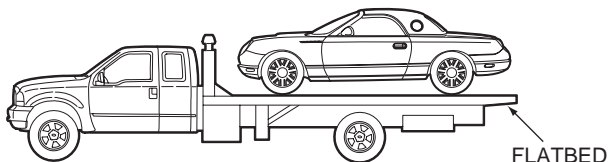
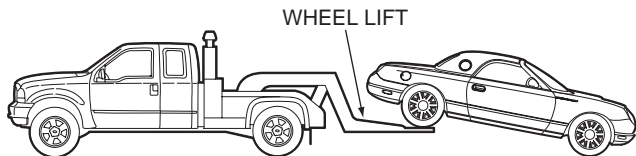

# FIVE HUNDRED, MONTEGO

## FRONT TOWING CONNECTIONS

**CAUTION:** Use care not to damage fog lamps on vehicles, if equipped.



**CAUTION:** It is required that the Five Hundred and Montego be towed with a wheel lift or flatbed equipment. Do not tow with a slingshot. Ford Motor Company has not approved a slingshot towing procedure. If the vehicle is towed by other means or incorrectly, vehicle damage may occur.

**CAUTION:** If the Five Hundred or Montego is to be towed from the front using wheel lift equipment, it is required that the rear wheels be placed on a dolly to prevent damage to the vehicle's rear bumper and AWD system (if equipped).

**CAUTION:** If the Five Hundred or Montego is to be towed from the front using wheel lift equipment, the front wheels must be raised to a height of 12 in (30 cm) ABOVE the rear wheels to prevent damage to the vehicle undercarriage.

**CAUTION:** If the Five Hundred or Montego is equipped with AWD, it is required to tow the vehicle with all wheels off the ground. Use wheel lift equipment and a dolly or a flatbed transport vehicle to prevent damage to the AWD system.

**NOTE:** Safety chains should be attached in the T-hook slots located on the underside of the rocker panels rearward of the front wheels.

**NOTE:** Refer to general towing information on pages 5 and 6 before towing vehicle.

TRANS	MPH/KMH	MILES/KMS
FWD	UNLTD	UNLTD
AWD with Dolly	UNLTD	UNLTD

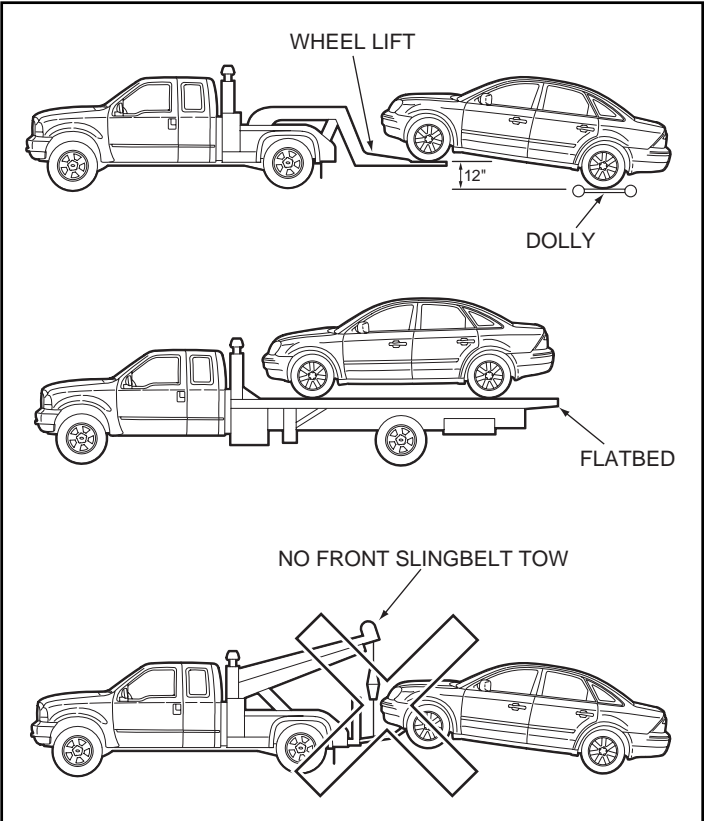

TRANS	MPH/KMH	MILES/KMS
FWD with Dolly	UNLTD	UNLTD
AWD with Dolly	UNLTD	UNLTD

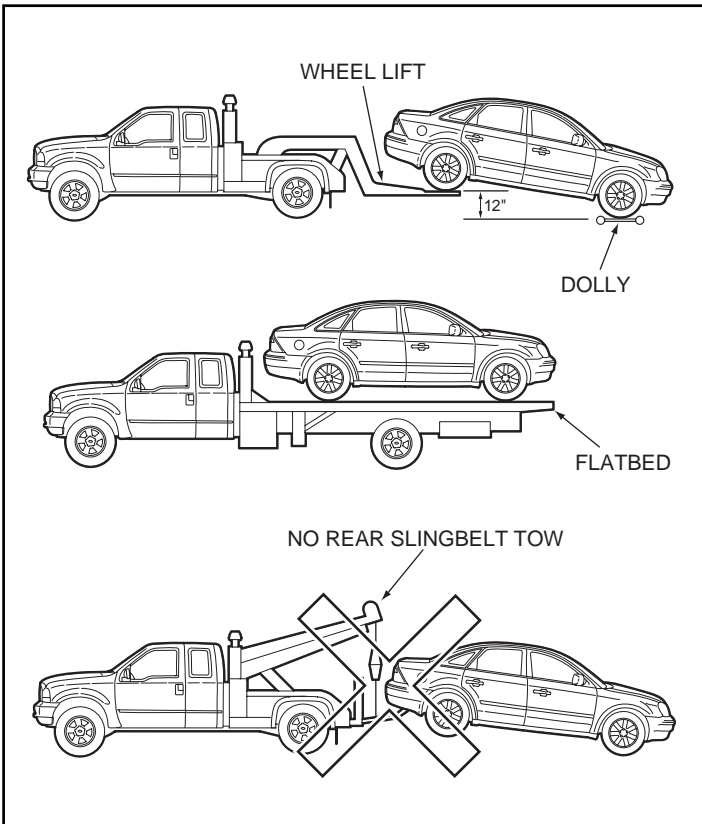

## FIVE HUNDRED, MONTEGO

### REAR TOWING CONNECTIONS

**CAUTION:** If the Five Hundred or Montego is to be towed from the rear using wheel lift equipment, it is required that the front wheels (drive wheels) be placed on a dolly to prevent damage to the transaxle and the vehicle.



**CAUTION:** It is required that the Five Hundred or Montego is towed with wheel lift or flatbed equipment. Do not tow with a slingbelt. Ford Motor Company has not approved a slingbelt towing procedure. If the vehicle is towed by other means or incorrectly, vehicle damage may occur.

**CAUTION:** If the Five Hundred or Montego is to be towed from the rear using wheel lift equipment, the rear wheels must be raised to a height of 12 in (30 cm) ABOVE the front wheels to prevent damage to the vehicle undercarriage.

**NOTE:** Safety chains should be attached in the T-hook slots located on the underside of the rocker panels forward of the rear wheels.

**NOTE:** Refer to general towing information on pages 5 and 6 before towing vehicle.

**PAGE LEFT BLANK INTENTIONALLY**



# GENERAL TOWING INFORMATION — LIGHT TRUCKS

## IMPORTANT SAFETY NOTICE

### NOTES AND CAUTIONS

As you read through the procedures, you will come across **NOTES** and **CAUTIONS**. Each one is there for a specific purpose. **NOTES** give you added information that will help to complete a particular procedure. **CAUTIONS** are given to prevent you from making an error that could damage the vehicle.

### Preparatory Steps

Release the parking brake and place the transmission/transaxle in NEUTRAL. As a general rule, vehicles should be towed with the drive wheels off the ground. If the vehicle is to be towed on its drive wheels, the transmission/transaxle and differential must be operable. If the transmission/transaxle is not operable, place the drive wheels on a dolly or disconnect the rear driveshaft (on rear wheel drive vehicles). If the differential is not operable, place the drive wheels on a dolly.

When a vehicle is towed on its front wheels, the steering wheel must be clamped in the straight ahead position with a steering wheel clamping device designed for towing service use, such as those provided by towing system manufacturers.

Do not use the vehicle's steering column lock to lock the wheels in a straight ahead position when pulled from the rear. If the ignition key is not available, place a dolly underneath the drive wheels of the vehicle and tow with the non-drive wheels raised.

### Brake-Shift Interlock

All Ford, Lincoln and Mercury vehicles, equipped with an automatic transmission/transaxle, incorporate a brake-shift interlock feature that prevents the gearshift lever from being moved from PARK when the ignition is in the ON position, unless the brake pedal is depressed. If you cannot move the gearshift lever out of PARK with the ignition in the ON position and the brake pedal depressed, refer to the automatic transmission or transaxle section in the driving section of the applicable Owner Guide.

**WARNING: DO NOT TOW VEHICLE BACKWARD WHEN TOWING THE VEHICLE WITH ALL FOUR WHEELS ON THE GROUND.**

When towing the vehicle with all four wheels on the ground, the steering wheel should be left unlocked.

**CAUTION: Improper towing of the vehicle could result in transmission/transaxle and/or transfer case damage. Always follow the outlined towing procedures. It is recommended that only an unloaded vehicle be towed.**

**IF TOWING WITH A LOAD IS UNAVOIDABLE, CARE MUST BE TAKEN TO PROPERLY RESTRAIN LOAD FROM SHIFTING AND DISTRIBUTE THE LOAD EVENLY IN THE PICKUP BOX.**

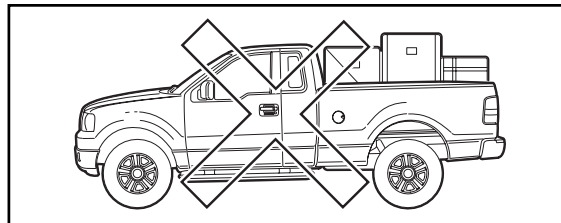

# GENERAL TOWING INFORMATION — LIGHT TRUCKS

## Towing Four-Wheel Drive Vehicles with Lever-Operated Transfer Case – F-150, F-250 through F-550

1. Place the transmission/transaxle automatic transmission in PARK or manual transmission in 1st gear.
2. Place the transfer case in N (NEUTRAL) on manually operated transfer case.

**NOTE:** The transfer case NEUTRAL setting is located between 4H and 4L. In order to place the transfer case in NEUTRAL, the lever must be moved slightly to the left and rearward of the 4H position. With the ignition in the ON position, both the 4x4 and LOW RANGE indicators will be OFF when the transfer case is in NEUTRAL. If the battery is dead, jump the vehicle to make sure the lights are off.

3. On a F-Super Duty, set the manual locking hubs to the FREE position.

**NOTE:** To verify that the hubs are in the FREE/AUTO position, the front driveshaft should turn freely.

Towing speed should not exceed 50 mph (80 km/h). This applies with either the front or rear wheels off the ground.

## Towing Four-Wheel Drive Vehicles with Electronic Shift Transfer Case

1. Place the transmission/transaxle automatic transmission in PARK or manual transmission in 1st gear.

**NOTE:** With the ignition in the ON position, both the 4x4 HI and the LOW RANGE indicators will be OFF when the transfer case is in NEUTRAL. If the battery is dead, jump the vehicle to make sure the lights are off.

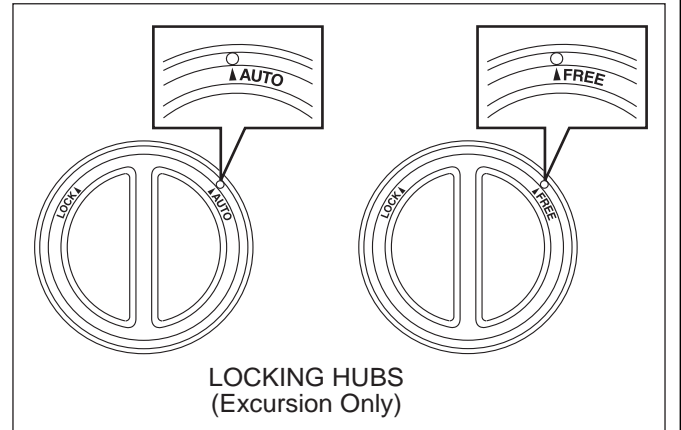
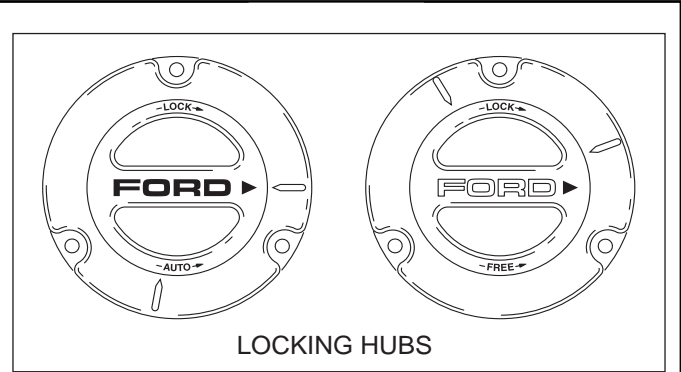

# GENERAL TOWING INFORMATION — LIGHT TRUCKS

2. Set the locking hubs to the AUTO position.

**NOTE:** Manual locking hubs apply to F-250 through F-550 and Excursion only.

Once these three conditions are met, follow the instructions for towing a two-wheel drive vehicle.

**WARNING: NEVER USE A TOW BAR THAT ATTACHES TO THE BUMPER WHEN TOWING THE VEHICLE. THE BUMPER COULD BE DAMAGED AND CAUSE AN ACCIDENT.**

**NOTE:** If a distance of 50 miles (80 km) and/or a speed of 35 mph (55 km/h) is exceeded, or when the vehicle is towed with the drive wheels on the ground, either position dollies under the wheels, or disconnect the driveshaft. Towing speed should not exceed 50 mph (80 km/h), when the vehicle is towed with the wheels off the ground. Do not tow with both front wheels on the ground.

## Flatbeds

**CAUTION: Improperly tying down a disabled vehicle may damage the vehicle's suspension, driveline or body parts.**

## Wheel Lift

**CAUTION: When towing over very rough or crowned intersection roads, the following special procedures are required when using any wheel lift equipment. The vehicle must be secured to the wheel lift equipment using safety chains equipped with T-hooks. If this procedure is not followed, damage to the underbody may result from excessive jounce travel of the suspension.**

1. Attach the safety chain T-hooks in the appropriate slot of the body or frame of the vehicle to be towed.
2. Run the chain through the hooks on the wheel lift crossbar and attach it to the towing vehicle.

3. For all vehicles except Freestyle, make sure that there is no slack in the safety chain between the vehicle to be towed and the crossbar.
4. Repeat steps 1 and 2 for the other side of the vehicle.

**NOTE:** Check vehicles' specifications for raised vehicle height requirements.

## Slingbelts/Chains/Hooks

Slingbelts may only be used when indicated in the towing procedure for a specific vehicle. When attaching slingbelts, take care to avoid damage to the license plate, fog lamps, etc., if equipped. Using a slingbelt when not indicated may cause damage to the bumper system, lower body panels or air dams.

**CAUTION: Use caution when attaching tow hooks and safety chains to vehicle. Position and remove hooks with care to avoid damage to brake hoses, brake lines and steering linkage components.**

**NOTE:** On vehicles equipped with bumper guards, make sure the slingbelt towbar is under the bumper and the weight of the vehicle is not supported by the bumper guards.

## Towing Speeds

See specific model instructions for vehicle towing speed and distance limitations.

UNLTD = Unlimited speed (50 mph/80 km/h) or mileage.

**On rough pavement, the maximum towing speed is 35 mph (55 km/h). Maximum towing speed of 35 mph (55 km/h) should be used whenever the tow truck operator is not sure of road surface conditions.**

**Refer to the dolly manufacturer for speed and weight limitations.**

# LIGHT TRUCK GVWR RATING

Vehicle line	VIN code 4th digit	GVWR	
		Kilograms (kg)	Pounds (lbs)
Aviator	E	2,722 - 3,175	6,001 - 7,000
Blackwood	E	2,722 - 3,175	6,001 - 7,000
Escape/Escape Hybrid	B	1,361 - 1,814	3,000 - 4,000
	U	1,361 - 1,814	3,000 - 4,000
	C	1,814 - 2,268	4,001 - 5,000
	Y	1,814 - 2,268	4,001 - 5,000
E-Series	R	2,722 - 3,175	6,001 - 7,000
	P	3,176 - 3,628	7,001 - 8,000
	V	3,629 - 3,855	8,001 - 8,500
	N	3,856 - 4,082	8,501 - 9,000
	S	4,083 - 4,535	9,001 - 10,000
	W	4,536 - 6,350	10,001 - 14,000
	X	6,351 - 7,257	14,001 - 16,000
	A	7,258 - 8,845	16,001 - 19,500
Excursion	N	3,629 - 3,855	8,501 - 9,000
F-Super Duty 250 - 550	S	4,083 - 4,535	9,001 - 10,000
	W	4,536 - 6,350	10,001 - 14,000
	X	6,351 - 7,257	14,001 - 16,000
	A	7,258 - 8,845	16,001 - 19,500
	H	3,629 - 3,855	8,501 - 9,000
	J	4,083 - 4,535	9,001 - 10,000
	K	4,536 - 6,350	10,001 - 14,000
	L	6,351 - 7,257	14,001 - 16,000
	M	7,258 - 8,845	16,001 - 19,500

Vehicle line	VIN code 4th digit	GVWR	
		Kilograms (kg)	Pounds (lbs)
Expedition Navigator	E	3,129 - 3,379	7,100 - 7,450
	F	3,129 - 3,379	7,100 - 7,450
	R	3,129 - 3,379	7,100 - 7,450
	P	3,129 - 3,379	7,100 - 7,450
Explorer	Z	2,269 - 2,721	5,001 - 6,000
Mountaineer	D	2,269 - 2,721	5,001 - 6,000
Explorer Sport Trac	D	2,269 - 2,721	5,001 - 6,000
	Z	2,269 - 2,721	5,001 - 6,000
F-150	V	3,630 - 3,855	8,001 - 8,500
LT	R	2,722 - 3,175	6,001 - 7,000
	P	3,176 - 3,628	7,001 - 8,000
	Y	1,814 - 2,268	4,001 - 5,000
Ranger	Z	2,269 - 2,721	5,001 - 6,000
Freestar	Z	2,269 - 2,721	5,001 - 6,000
Monterey	D	2,269 - 2,721	5,001 - 6,000
Freestyle	F	2,269 - 2,721	5,000 - 6,000

# WRECKER TOWING FORD VEHICLES WITH AIR BAGS

## General Information

An air bag is highly unlikely to deploy during wrecker towing. Standard wrecker towing or recovery procedures on an air bag equipped vehicle should not cause air bag deployment. Only a significant frontal impact that closes two crash sensors will deploy an air bag.

## How to Determine if a Ford Vehicle has Air Bags

- The fourth position of all Ford light truck VINs is the letter:
  - “A, P, R, U, V, W, X, Y or Z” if equipped with driver and passenger air bags.
  - “B, C, D, E, F, N or S” if equipped with driver and passenger air bags, plus driver and passenger side air bags, curtains or canopies.
  - “H, J, K, L or M” if **not** equipped with air bags.
- The steering wheel hub will also be larger and more rectangular (about 6 in x 9 in). The passenger-side air bag module trim covers will be moulded with “SRS”.

## Is it Necessary to Disable the Air Bag System for Wrecker Towing?

- Disabling the air bag system is **not** necessary in most cases.
- As a precaution, disconnect the battery in a safe manner when the vehicle has significant damage to the front of the vehicle and an undeployed air bag.

**NOTE:** Turning the ignition switch to OFF will **not** disable the Ford air bag system. The air bag deployment system operates independently of the ignition key position.

## Wrecker Towing a Vehicle with Deployed Air Bags

- Deployed air bags are **not** dangerous.
- Any powdery residue consists of corn starch or talcum powder and sodium compounds, mostly sodium carbonates (e.g., baking soda) accompanied by very minute deposits of sodium hydroxide that can be irritating to the skin and eyes but poses no long-term health hazard.

# FREESTYLE

## FRONT TOWING CONNECTIONS

**CAUTION:** Use care not to damage fog lamps on vehicles, if equipped.



**CAUTION:** It is required that the Freestyle be towed with a wheel lift or flatbed equipment. Do not tow with a slingbelt. Ford Motor Company has not approved a slingbelt towing procedure. If the vehicle is towed by other means or incorrectly, vehicle damage may occur.

**CAUTION:** If the Freestyle is to be towed from the front using wheel lift equipment, the front wheels must be raised to a height of 12 in (30 cm) ABOVE the rear wheels to prevent damage to the vehicle body.

**CAUTION:** If the Freestyle is equipped with AWD, it is required to tow the vehicle with all wheels off the ground. Use wheel lift equipment and a dolly or a flatbed transport vehicle to prevent damage to the AWD system.

**NOTE:** Safety chains should be attached in the T-hook slots located on the underside of the rocker panels rearward of the front wheels.

**NOTE:** Refer to general towing information on pages 25 through 28 before towing vehicle.

TRANS	MPH/KMH	MILES/KMS
FWD	UNLTD	UNLTD
AWD with Dolly	UNLTD	UNLTD

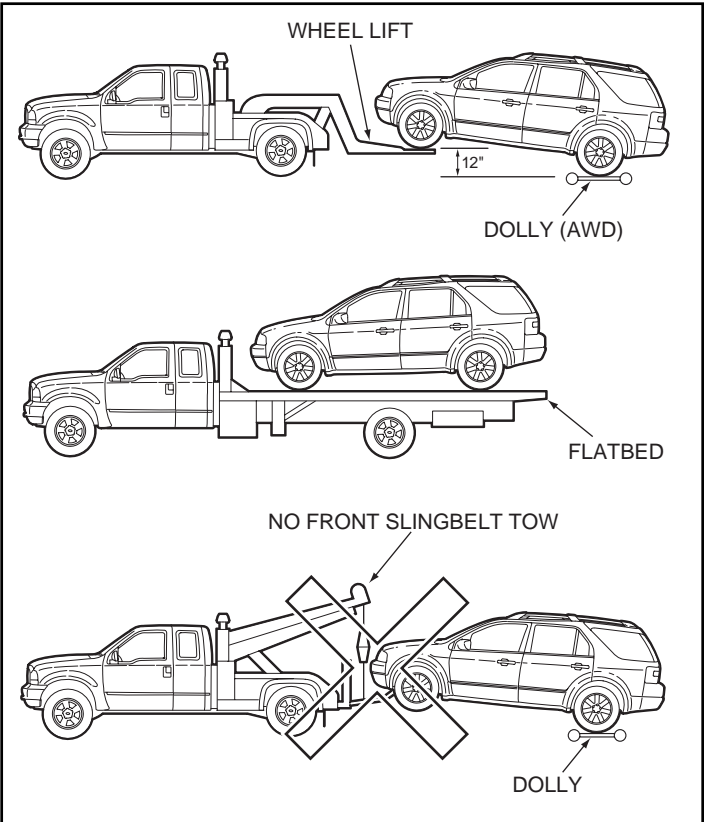

TRANS	MPH/KMH	MILES/KMS
FWD with Dolly	UNLTD	UNLTD
AWD with Dolly	UNLTD	UNLTD

## FREESTYLE

### REAR TOWING CONNECTIONS

**CAUTION:** If the Freestyle is to be towed from the rear using wheel lift equipment, it is required that the front wheels (drive wheels) be placed on a dolly to prevent damage to the transaxle and the vehicle.



**CAUTION:** It is required that the Freestyle be towed with a wheel lift or flatbed equipment. Do not tow with a slingbelt. Ford Motor Company has not approved a slingbelt towing procedure. If the vehicle is towed by other means or incorrectly, vehicle damage may occur.

**CAUTION:** If the Freestyle is to be towed from the rear using wheel lift equipment, the rear wheels must be raised to a height of 12 in (30 cm) ABOVE the front wheels to prevent damage to the vehicle body.

**NOTE:** Safety chains should be attached in the T-hook slots located on the underside of the rocker panels forward of the rear wheels.

**NOTE:** Refer to general towing information on pages 25 through 28 before towing vehicle.

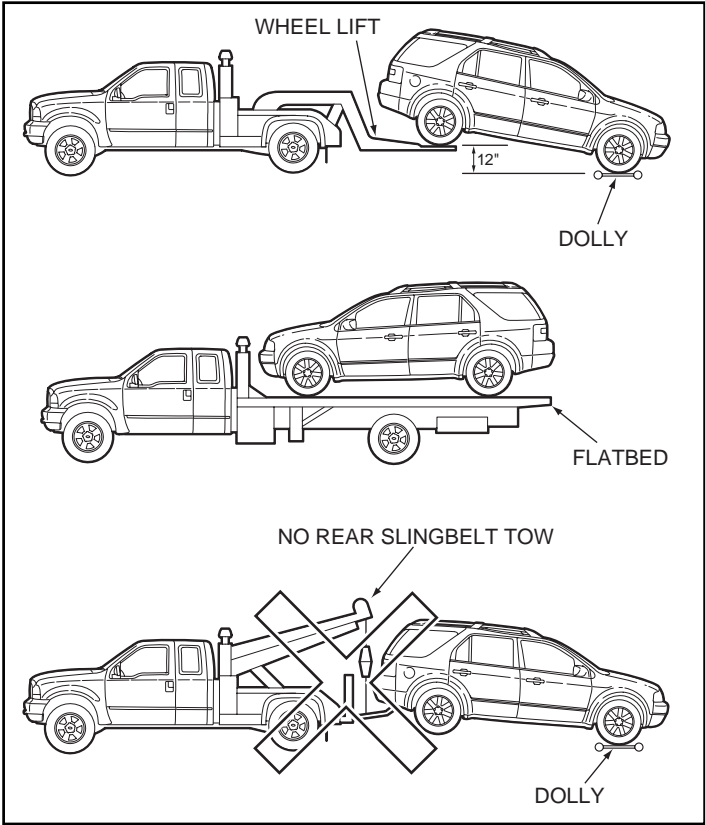

# FREESTAR, MONTEREY

## FRONT AND REAR TOWING CONNECTIONS

**CAUTION:** If the Freestar, Monterey is to be towed from the rear using wheel lift equipment, the front wheels (drive wheels) must be placed on a dolly to prevent damage to the transaxle.



**CAUTION:** It is recommended that the Freestar, Monterey be towed with a wheel lift or flatbed equipment. Do not tow with a slingbelt. Ford Motor Company has not approved a slingbelt towing procedure. If the vehicle is towed by other means or incorrectly, vehicle damage may occur.

**NOTE:** Refer to general towing information on pages 25 through 28 before towing vehicle.

TRANS	MPH/KMH	MILES/KMS
AUTO without Dolly	35/56	50/80
AUTO with Dolly	UNLTD	UNLTD

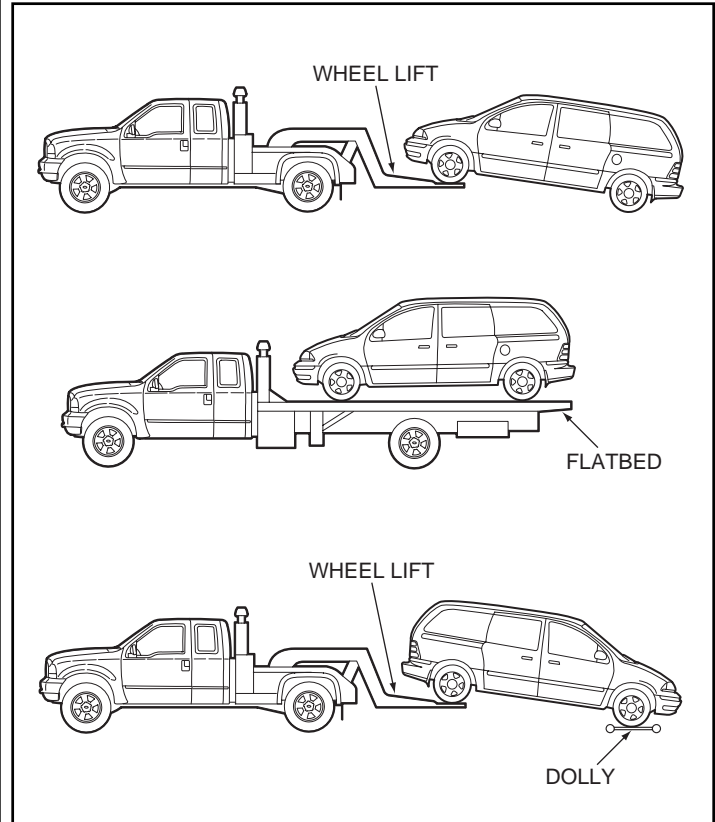





TRANS	MPH/KMH	MILES/KMS
AUTO/4x2 without Dolly	35/56	50/80
AUTO with Dolly	UNLTD	UNLTD

## AVIATOR, EXPLORER, MOUNTAINEER

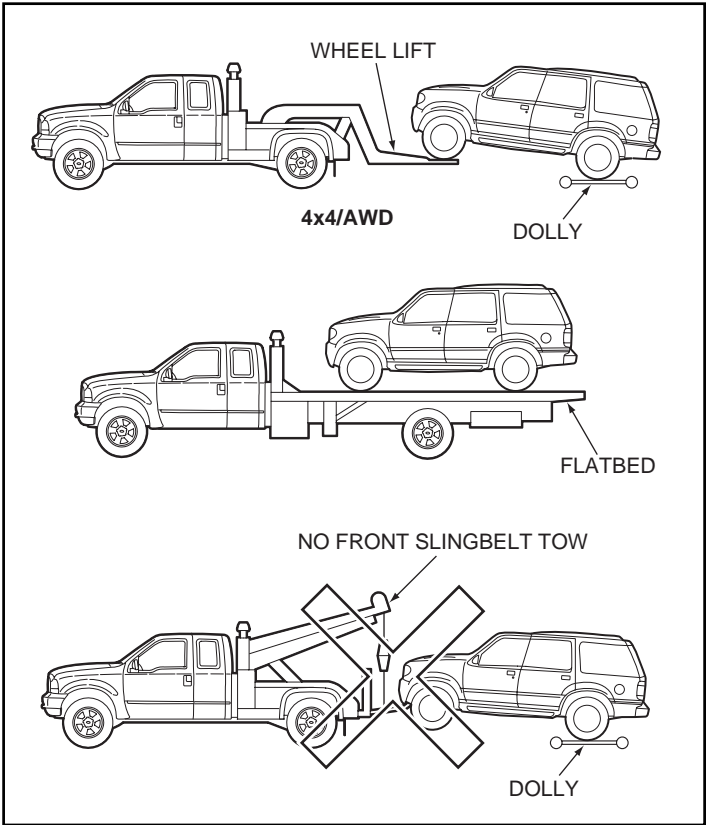
### FRONT TOWING CONNECTIONS



**CAUTION:** It is recommended that the Aviator, Explorer, Mountaineer (4x2, 4x4/AWD) be towed with a wheel lift or flatbed equipment.  Do not tow with a slingbelt. Ford Motor Company has not approved a slingbelt towing procedure. If the vehicle is towed by other means or incorrectly, vehicle damage may occur.

**NOTE:** Refer to general towing information on pages 25 through 28 before towing vehicle.

**NOTE:** On a AWD vehicle, it is required that the vehicle be towed with a wheel lift or flatbed equipment with all the wheels off the ground.

## AVIATOR, EXPLORER, MOUNTAINEER

### REAR TOWING CONNECTIONS

**CAUTION:** It is recommended that the Aviator, Explorer, Mountaineer (4x2, 4x4) be towed with a wheel lift or flatbed equipment. Do not tow with a slingbelt. Ford Motor Company has not approved a slingbelt towing procedure. If the vehicle is towed by other means or incorrectly, vehicle damage may occur.

**NOTE:** Refer to general towing information on pages 25 through 28 before towing vehicle.

**NOTE:** On a 4x2 vehicle, it is acceptable to tow the vehicle with the front wheels on the ground (without dollies) and the rear wheels off the ground.

**NOTE:** On a 4x4/AWD vehicle, it is required that the vehicle be towed with a wheel lift or flatbed equipment with all the wheels off the ground.



TRANS	MPH/KMH	MILES/KMS
AUTO/4x2 without Dolly	35/56	50/80
AUTO with Dolly	UNLTD	UNLTD

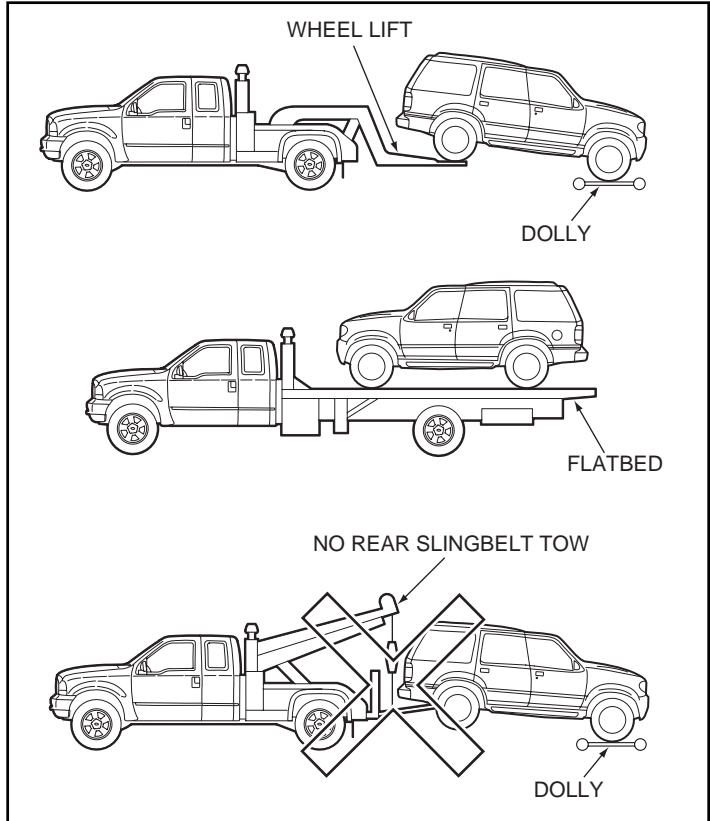

TRANS	MPH/KMH	MILES/KMS
AUTO	35/56	50/80
AUTO with Dolly	UNLTD	UNLTD

## SPORT-TRAC

### FRONT TOWING CONNECTIONS

**CAUTION:** It is recommended that the Sport-Trac (4x2, 4x4) be towed with a wheel lift or flatbed equipment. Do not tow with a slingbelt. Ford Motor Company has not approved a slingbelt towing procedure. If the vehicle is towed by other means or incorrectly, vehicle damage may occur.



**NOTE:** Refer to general towing information on pages 25 through 28 before towing vehicle.

**NOTE:** On all vehicles, it is recommended that the vehicle be towed with a wheel lift or flatbed equipment with all the wheels off the ground.

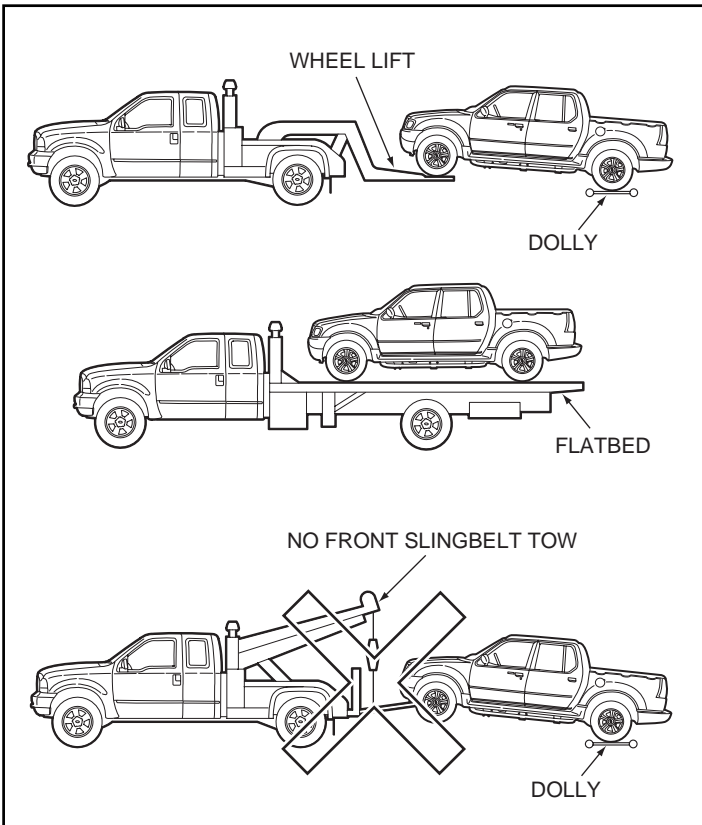

# SPORT-TRAC

## REAR TOWING CONNECTIONS

**CAUTION:** It is recommended that the Sport-Trac be towed with a wheel lift or flatbed equipment. Do not tow with a slingbelt. Ford Motor Company has not approved a slingbelt towing procedure. If the vehicle is towed by other means or incorrectly, vehicle damage may occur.



**CAUTION:** On a 4x4 vehicle in 4 HI or 4 LOW, it is required that the vehicle be towed with a wheel lift or flatbed equipment with all of the wheels off the ground.

**NOTE:** Refer to general towing information on pages 25 through 28 before towing vehicle.

TRANS	MPH/KMH	MILES/KMS
AUTO	UNLTD	UNLTD

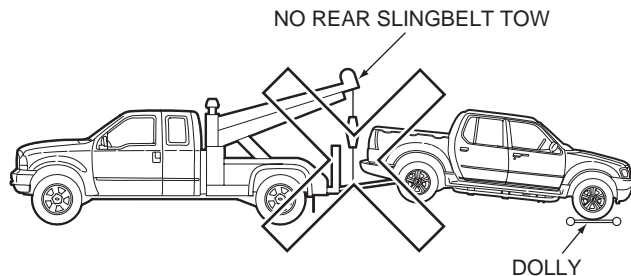
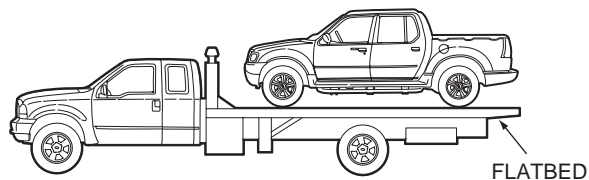
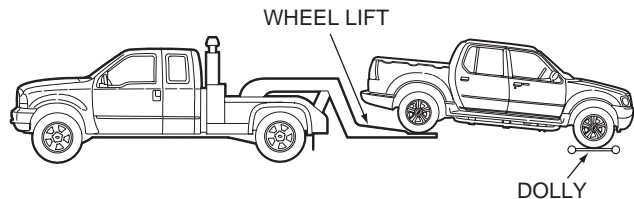

TRANS	MPH/KMH	MILES/KMS
AUTO with Dolly	UNLTD	UNLTD
AUTO without Dolly	35/56	55/80
MANUAL without Dolly	UNLTD	UNLTD

# RANGER

## FRONT TOWING CONNECTIONS

**CAUTION:** It is recommended that the Ranger (4x2, 4x4) be towed with a wheel lift or flatbed equipment. Do not tow with a slingbelt. Ford Motor Company has not approved a slingbelt towing procedure. If the vehicle is towed by other means or incorrectly, vehicle damage may occur.



**CAUTION:** If the Ranger STX is to be towed from the front using wheel lift equipment, the front wheels must be raised to a minimum height of 20 in (51 cm) ABOVE the rear wheels to prevent damage to the front fascia.

**NOTE:** Refer to general towing information on pages 25 through 28 before towing vehicle.

**NOTE:** On all vehicles, it is recommended that the vehicle be towed with a wheel lift and dolly or flatbed equipment with all the wheels off the ground.

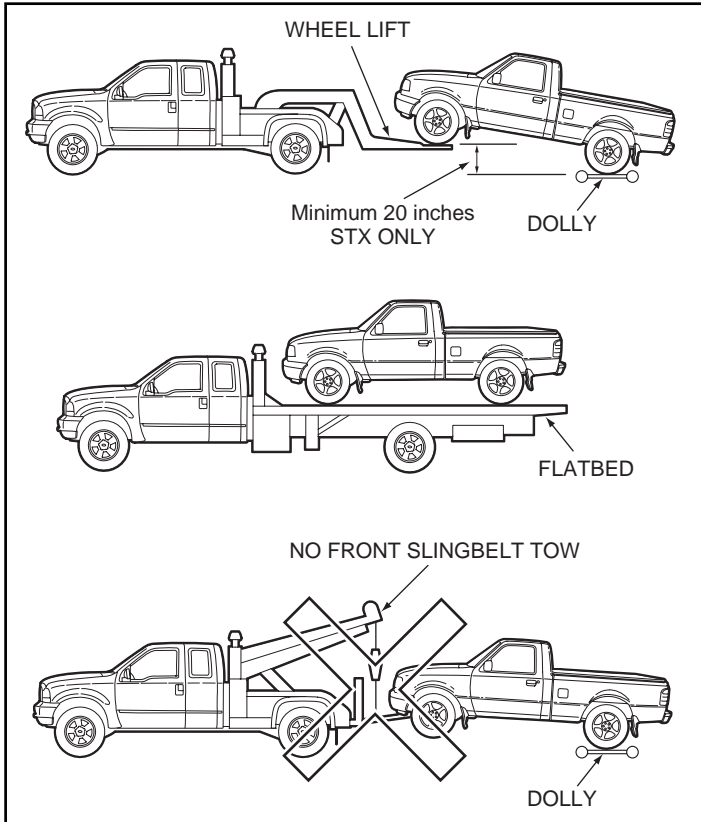

# RANGER

## REAR TOWING CONNECTIONS

**CAUTION:** It is recommended that the Ranger be towed with a wheel lift or flatbed equipment. Do not tow with a slingbelt. Ford Motor Company has not approved a slingbelt towing procedure. If the vehicle is towed by other means or incorrectly, vehicle damage may occur.



**NOTE:** Refer to general towing information on pages 25 through 28 before towing vehicle.

**NOTE:** All STX models must have dollies under the front wheels when towed from the rear to avoid damaging the front fascia. All others (4x2 and 4x4 in 2 HI) can be towed with the front wheels on the ground and the rear wheels off the ground.

TRANS	MPH/KMH	MILES/KMS
AUTO	UNLTD	UNLTD
MANUAL	UNLTD	UNLTD

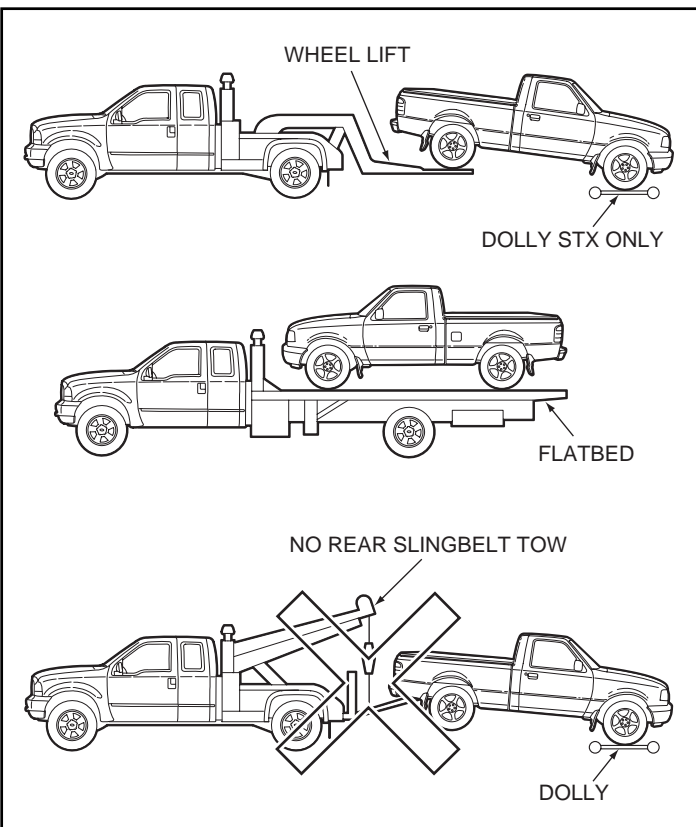

TRANS	MPH/KMH	MILES/KMS
MANUAL/AUTO 2WD	35/56	50/80
4x4 with Dolly	UNLTD	UNLTD

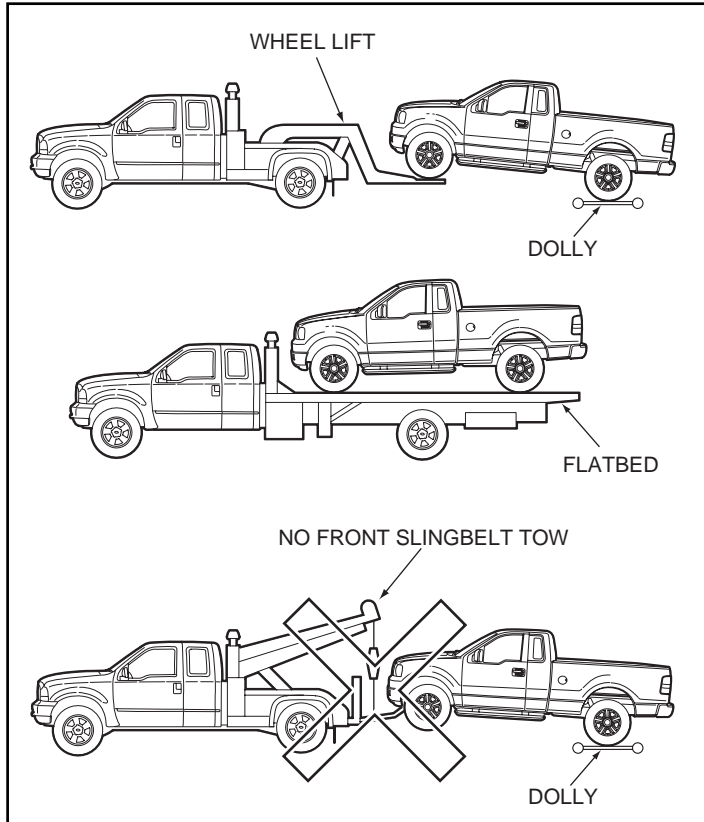

## F-150, NAVIGATOR, EXPEDITION, MARK LT

### FRONT TOWING CONNECTIONS

**CAUTION:** It is recommended that the vehicle be towed with a wheel lift or flatbed equipment. Do not tow with a slingbelt. Ford Motor Company has not approved a slingbelt towing procedure. If the vehicle is towed by other means or incorrectly, vehicle damage may occur.



**CAUTION:** If the vehicle is equipped with air suspension, the air suspension control must be turned to the OFF position. For Expedition and Navigator, the air suspension shut-off switch is located behind an access panel on the left rear quarter trim panel, near the liftgate. For all other vehicles, the control is located behind an access panel beneath the passenger side of the instrument panel.

**NOTE:** Refer to general towing information on pages 25 through 28 before towing vehicle.

**NOTE:** On a 4x4 vehicle with a Lever-Operated transfer case in NEUTRAL, it is acceptable to tow the vehicle with the rear wheels on the ground.

## F-150, NAVIGATOR, EXPEDITION, MARK LT

### REAR TOWING CONNECTIONS

#### DO NOT TOW WITH SLINGBELT EQUIPMENT

**CAUTION:** It is recommended that the vehicle be towed with a wheel lift or flatbed equipment. Do not tow with a slingbelt. Ford Motor Company has not approved a slingbelt towing procedure. If the vehicle is towed by other means or incorrectly, vehicle damage may occur.



**CAUTION:** If the vehicle is equipped with air suspension, the air suspension control must be turned to the OFF position. For Expedition and Navigator, the air suspension shut-off switch is located behind an access panel on the left rear quarter trim panel, near the liftgate. For all other vehicles, the control is located behind an access panel beneath the passenger side of the instrument panel.

**CAUTION:** On a 4x4 Control Trac System (Expedition and Navigator), the vehicle must be towed with the wheels on a dolly or flatbed.

**NOTE:** Refer to general towing information on pages 25 through 28 before towing vehicle.

TRANS	MPH/KMH	MILES/KMS
MANUAL/AUTO 2WD	UNLTD	UNLTD
4x4 with Dolly	UNLTD	UNLTD

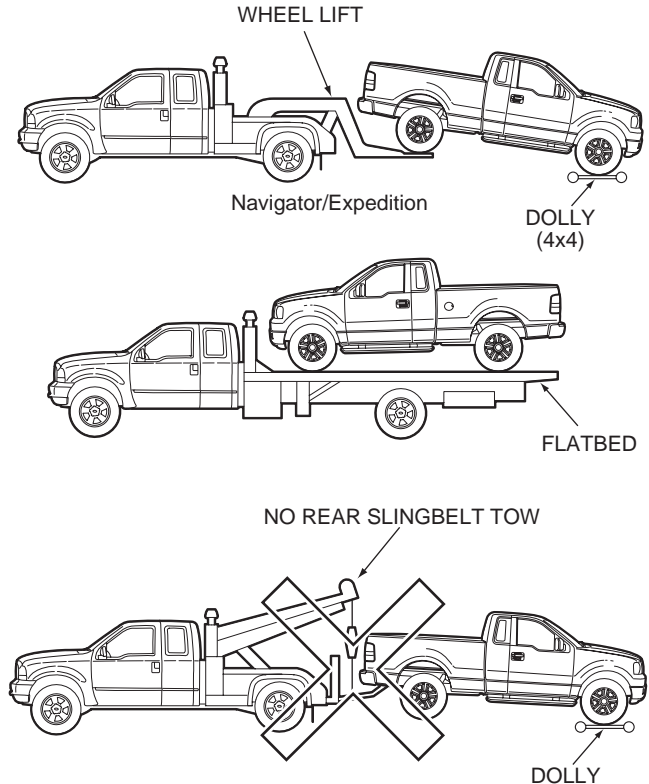



TRANS	MPH/KMH	MILES/KMS
*Auto, 2WD	35/56	50/80
**Auto, 4x4 ESOF with rear wheel dolly	UNLTD	UNLTD
Auto, MSOS	UNLTD	UNLTD
Manual	UNLTD	UNLTD

\*Exceeding speed or mileage may cause auto transmission damage.  
 \*\*Towing 4x4 ESOF with rear wheels on ground may cause transmission damage.

## FRONT TOWING CONNECTIONS

**CAUTION: It is recommended that the vehicle be towed with a wheel lift or flatbed equipment. Do not tow with a slingbelt. Ford Motor Company has not approved a slingbelt towing procedure. If the vehicle is towed by other means or incorrectly, vehicle damage may occur.**



**NOTE:** Refer to general towing information on pages 25 through 28 before towing vehicle.

- Insert T-hooks in T-hook slots in the blocker beam slots that are located in the flattened portion of the beam at each end.

**NOTE:** Some F-450 and F-550 vehicles may include or be equipped with aftermarket equipment. These components could be damaged using a wheel lift. Refer to the body builders information for towing instructions.

**NOTE:** On a 4x4 vehicle with Electronic Shift on the Fly (ESOF), it is recommended that the vehicle be towed with a wheel lift and dolly or flatbed equipment with all the wheels off the ground.

**NOTE:** On a 4x4 vehicle with Manual Shift on Stop (MSOS) with the transfer case in NEUTRAL it is acceptable to tow the vehicle with the rear wheels on the ground and the transmission in PARK.

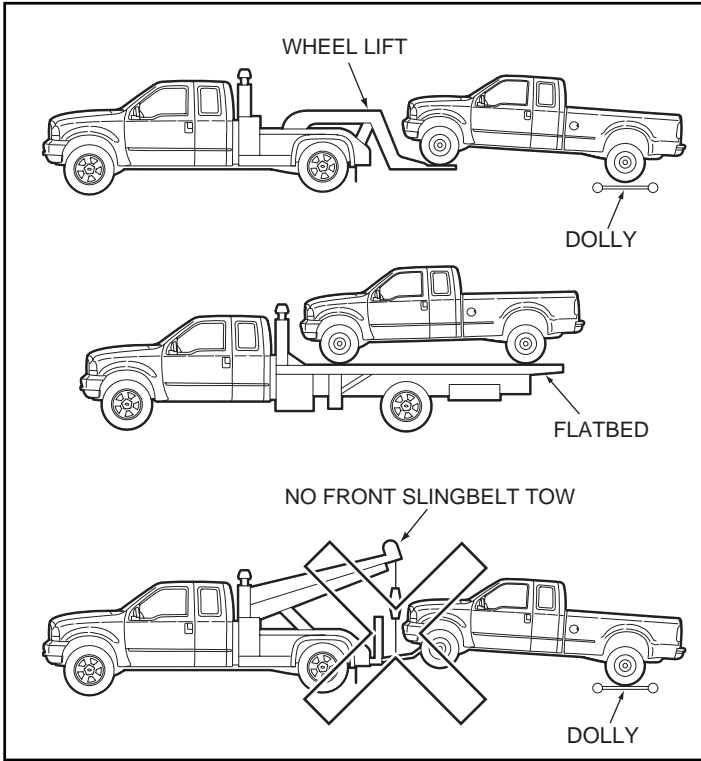

## REAR TOWING CONNECTIONS

**CAUTION:** It is recommended that the vehicle be towed with a wheel lift or flatbed equipment. Do not tow with a slingbelt. Ford Motor Company has not approved a slingbelt towing procedure. If the vehicle is towed by other means or incorrectly, vehicle damage may occur.



**NOTE:** Refer to general towing information on pages 25 through 28 before towing vehicle.

- Attach T-hooks in T-hook slots on frame rail.

**NOTE:** Some F-450 and F-550 vehicles may include or be equipped with aftermarket equipment. These components could be damaged using a wheel lift. Refer to the body builder information for towing instructions.

**NOTE:** On a 4x2/4x4 vehicle in 2 HI and the hubs in the AUTO/FREE position, it is acceptable to tow the vehicle with the front wheels on the ground (without dollies) and the rear wheels off the ground.

TRANS	MPH/KMH	MILES/KMS
Auto, 2WD	UNLTD	UNLTD
*Auto, 4x4 ESOF with front hubs free	UNLTD	UNLTD
Manual	UNLTD	UNLTD
*Towing 4x4 ESOF from the rear with the front hubs engaged may cause auto transmission damage.		

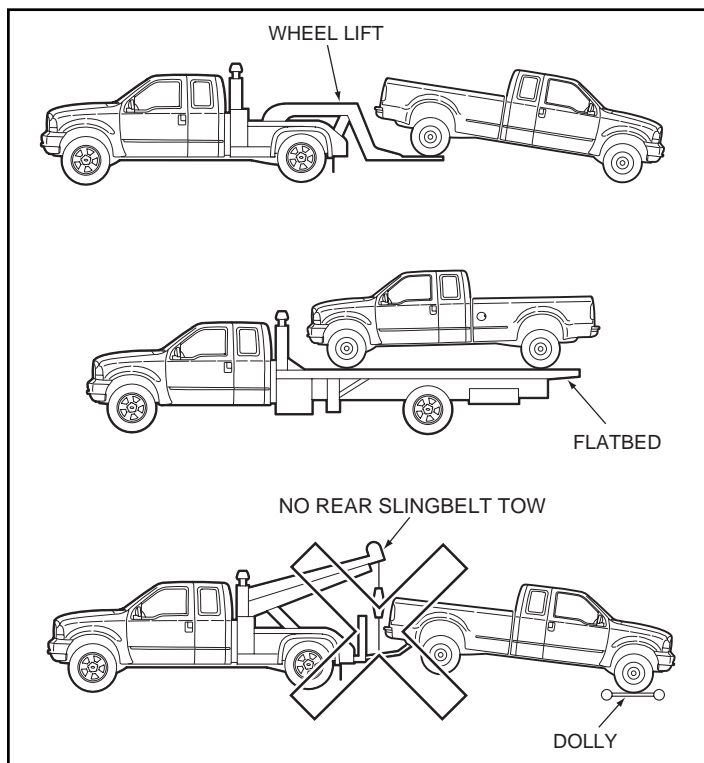

TRANS	MPH/KMH	MILES/KMS
AUTO with Dolly	UNLTD	UNLTD
AUTO/4x2 without Dolly	35/56	50/80

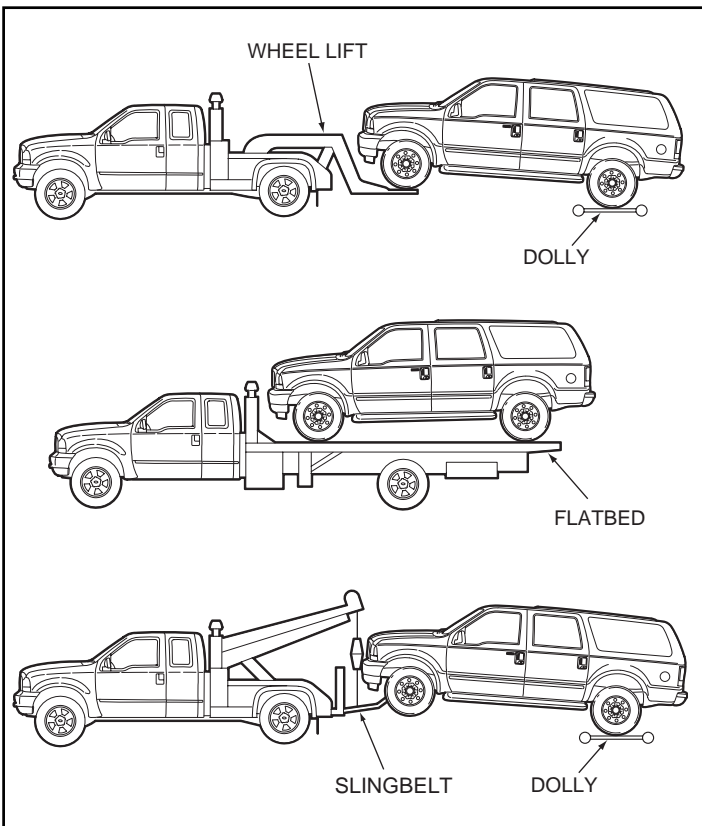

## EXCURSION

### FRONT TOWING CONNECTIONS

**CAUTION:** When towing the Excursion, a crossbeam should be used with 4x4 models, to avoid potential damage to the lower radiator support and oil cooler lines. Do not use a crossbeam on 4x2 models. If the vehicle is towed by other means or incorrectly, vehicle damage may occur.



**NOTE:** Refer to general towing information on pages 25 through 28 before towing vehicle.

- Insert T-hooks in T-hook slots in the blocker beam slots that are located in the flattened portion of the beam at each end.
- Position 4x4 crossbeam under each leaf spring, supported at the tow chains and sling tow bar.
- Attach safety chain around axle.

**NOTE:** On 4x4 vehicles it is required that the vehicle be towed with all the wheels off the ground. However, a slingbelt with T-hooks and a dolly can be used.

# EXCURSION

## REAR TOWING CONNECTIONS

**CAUTION: Towing a 4x4 with Electronic Shift on the Fly (ESOF) from the rear with the hubs in the Engaged/Lock position may cause automatic transmission damage. If the vehicle is towed by other means or incorrectly, vehicle damage may occur.**



**NOTE:** Refer to general towing information on pages 25 through 28 before towing vehicle.

- Attach T-hooks in T-hook slots on frame rail or frame-mounted trailer hitch.
- Locate the slingbelt under the rear bumper or frame-mounted trailer hitch.
- Attach safety chain around rear axle.

**NOTE:** On 4x2/4x4 vehicles in 2 HI with hubs in the FREE/AUTO position, it is acceptable to tow the vehicle with the front wheels on the ground (without dollies) and the rear wheels off the ground using a wheel lift or a slingbelt with T-hook.

TRANS	MPH/KMH	MILES/KMS
AUTO	UNLTD	UNLTD

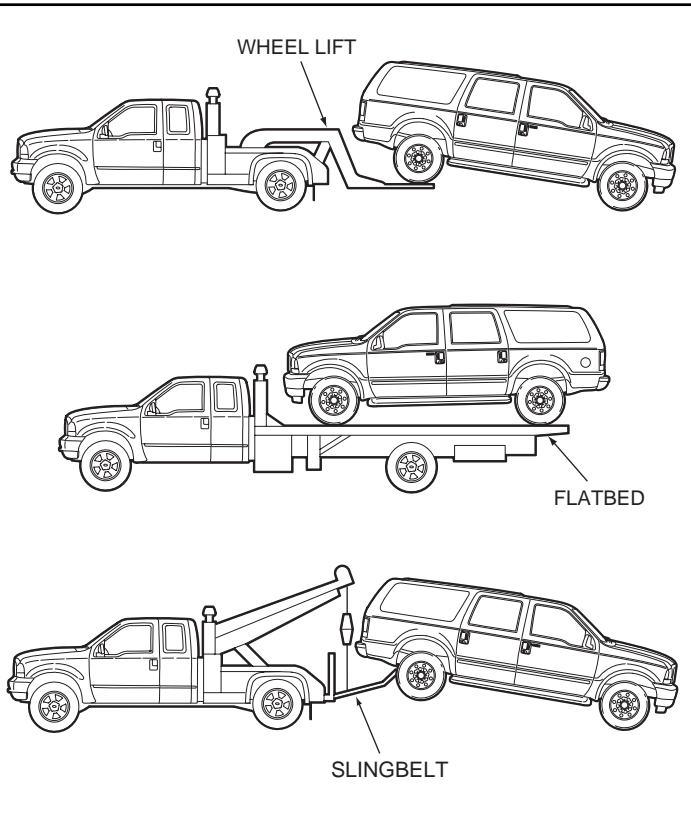

TRANS	MPH/KMH	MILES/KMS
FWD	UNLTD	UNLTD
4x4 with Dolly	UNLTD	UNLTD

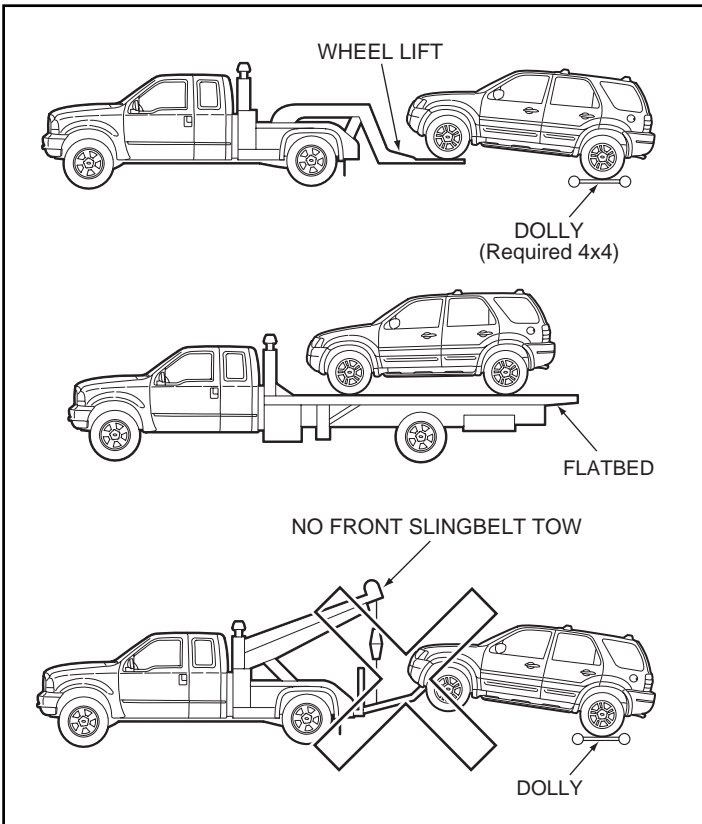

## ESCAPE, ESCAPE HYBRID

### FRONT TOWING CONNECTIONS

**CAUTION:** It is recommended that the Escape (FWD, 4x4) be towed with a wheel lift or flatbed equipment. Do not tow with a slingbelt. Ford Motor Company has not approved a slingbelt towing procedure. If the vehicle is towed by other means or incorrectly, vehicle damage may occur.



**NOTE:** On a FWD vehicle, it is acceptable to tow the vehicle with the rear wheels on the ground and the front wheels off the ground.

**NOTE:** On a 4x4 vehicle, it is required that the vehicle be towed with a wheel lift and dolly or flatbed equipment with all the wheels off the ground.

**NOTE:** Refer to general towing information on pages 25 through 28 before towing vehicle.

# ESCAPE, ESCAPE HYBRID

## REAR TOWING CONNECTIONS

**CAUTION:** If the Escape (FWD, 4x4) is to be towed from the rear using wheel lift equipment, the front wheels (drive wheels) must be placed on a dolly to prevent damage to the transaxle.



**CAUTION:** It is recommended that the Escape be towed with a wheel lift or flatbed equipment. Do not tow with a slingbelt. Ford Motor Company has not approved a slingbelt towing procedure. If the vehicle is towed by other means or incorrectly, vehicle damage may occur.

**NOTE:** Refer to general towing information on pages 25 through 28 before towing vehicle.

TRANS	MPH/KMH	MILES/KMS
AUTO with Dolly	UNLTD	UNLTD

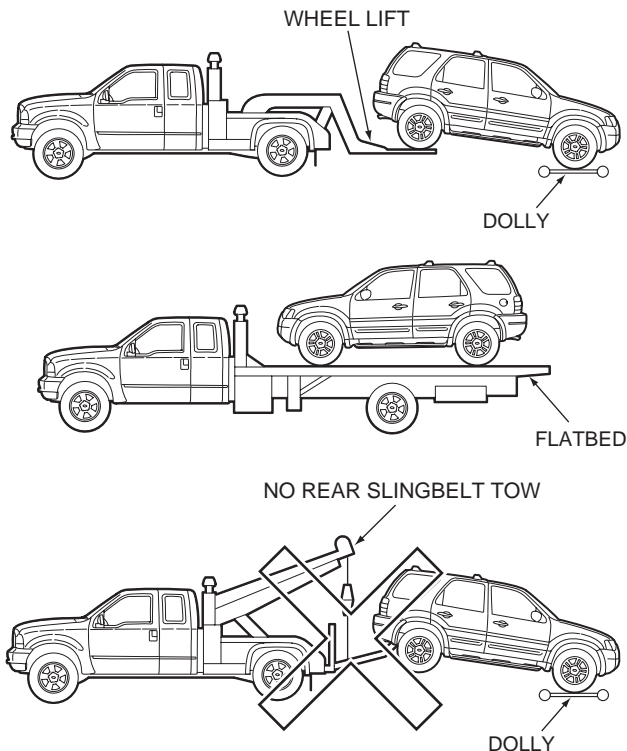

TRANS	MPH/KMH	MILES/KMS
AUTO	35/56	50/80

## E-SERIES, CLUB WAGON, E-150, E-250, E-350, E-450

### FRONT TOWING CONNECTIONS — SLINGBELT

**CAUTION:** If the vehicle is equipped with an air dam and must be towed from the front, it is recommended that the vehicle be towed with a wheel lift or flatbed equipment to prevent damage to the air dam. If the vehicle is towed by other means or incorrectly, vehicle damage may occur.



**CAUTION:** It is recommended that the E-Series vehicles be towed with a wheel lift or flatbed equipment. However, a slingbelt with T-hooks can also be used.

**CAUTION:** When towing E-Series vehicles, spacer blocks must be used with a 4x4 crossbeam.

**NOTE:** Refer to general towing information on pages 25 through 28 before towing vehicle.

- Insert T-hooks in horizontal T-hook slots in frame.
- Place spacer blocks and 4x4 crossbeam behind bumper and air dam and across frame rails. Make sure that spacer blocks are under frame rails.
- Attach safety chains around axle, outboard of coil springs.

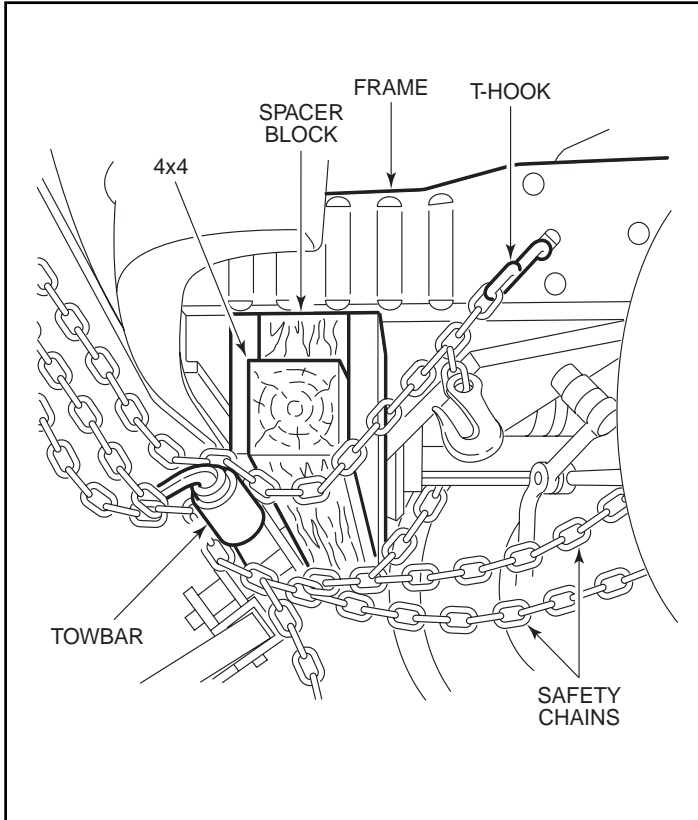

## E-SERIES, CLUB WAGON, E-150, E-250, E-350, E-450

### REAR TOWING CONNECTIONS

**CAUTION:** It is recommended that E-Series vehicles be towed with a wheel lift or flatbed equipment. However, a slingbelt with T-hooks can also be used. If the vehicle is towed by other means or incorrectly, vehicle damage may occur.



**NOTE:** Refer to general towing information on pages 25 through 28 before towing vehicle.

- Attach T-hooks in T-hook slots on frame rail, inside the leaf spring.
- Route chains below spring shackles, on the right side route chain above tail pipe.
- Place towbar under rear bumper, missing spare tire.
- Attach safety chain around rear axle. Route chain between axle and parking brake cable on RH side.

TRANS	MPH/KMH	MILES/KMS
AUTO	UNLTD	UNLTD

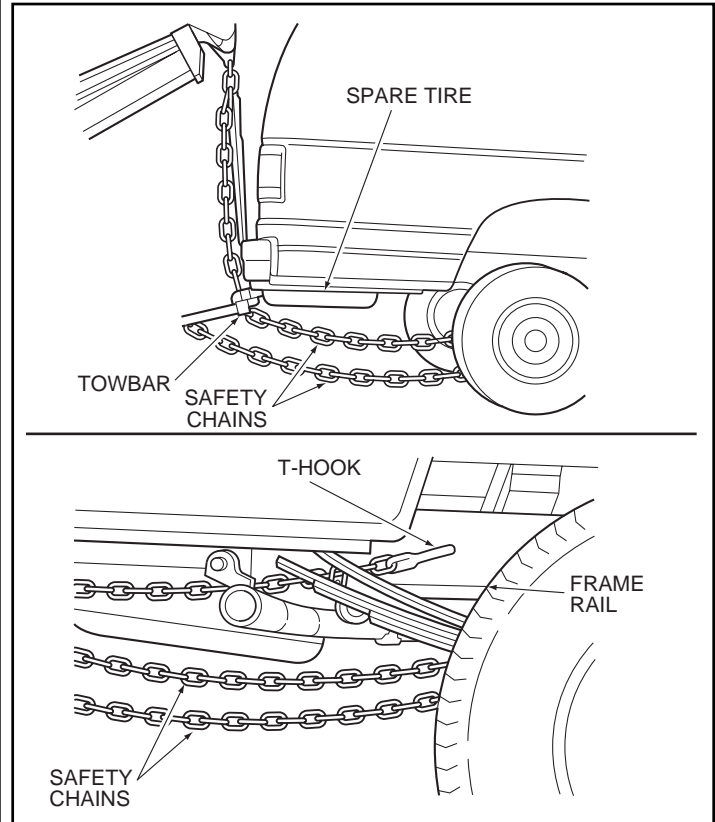



## **2005 FORD SERVICE INFORMATION**

With our 2005 Service Information, you can repair Ford, Lincoln and Mercury Cars and Light Trucks in an expert manner and ensure customer satisfaction. The low cost of this information is an investment in the growth of your business.

### **WORKSHOP MANUALS**

Now available on DVD-ROM, Workshop Manuals provide complete maintenance and repair procedures. Both Car and Truck Workshop Manuals cover Body, Chassis, Electrical, Powertrain, Pre-Delivery and Emissions. A “must” to do the job right the first time.

### **WIRING DIAGRAMS**

Provide schematics of all electrical components and identify each wire to its proper function.

### **PUBLICATIONS ORDERING INFORMATION**

To obtain information about ordering additional copies of this publication or to order any other Ford or Lincoln/Mercury publication write to: Ford Publications, care of Helm Inc., P.O. Box 07150, Detroit, MI 48207.