

## ABOUT THIS MANUAL

Ford Motor Company salutes the towing industry and applauds you for your many fine years of service to the automotive industry. We will continue to work with you to provide our customers and yours with guidelines.

This manual contains the latest towing procedures for 2007 Ford, Lincoln and Mercury passenger cars and light trucks. As you turn the pages of this book, you will find the instructions easy to follow with clear illustrations showing the correct hook-up for damage-free towing.

As an additional safety measure, be sure you use safety chains on every tow, including wheel lift and flatbed hook-ups. This will prevent you from losing the vehicle in the event of equipment failure or vehicle breakage at the tow chain attachment.

New materials and aerodynamic styling require new methods of towing to eliminate the possibility of vehicle towing damage. Wheel lifts and flatbed equipment are required to tow many vehicles. Refer to the instructions given for the specific vehicle you are towing.

## FOREWORD

**This manual contains information for the proper and safe towing of Ford Motor Company passenger cars and light trucks using slingbelt, wheel lift and flatbed wrecker towing equipment.**

**CAUTION: To help avoid personal injury and/or vehicle damage, thoroughly review the information in this manual and carefully follow all notes, cautions, warnings and procedures.**

**NOTE: Due to the many variations of wrecker towing equipment, specific instructions for equipment usage is not included in this manual. Refer instead to the instruction manuals supplied with the slingbelt, wheel lift or flatbed equipment.**

# TABLE OF CONTENTS

	Page
Foreword .....	2
<b>TOWING EQUIPMENT .....</b>	<b>4</b>
<b>GENERAL TOWING INFORMATION — PASSENGER CARS .....</b>	<b>5-6</b>
<b>WRECKER TOWING FORD VEHICLES WITH AIR BAGS .....</b>	<b>7</b>
<b>PASSENGER CAR TOWING</b>	
Taurus .....	8-9
Focus .....	10-11
Town Car, Crown Victoria, Grand Marquis .....	12-13
Mustang.....	14-15
Fusion, Milan, MKZ .....	16-17
Five Hundred, Montego .....	18-19
<b>GENERAL TOWING INFORMATION — LIGHT TRUCKS .....</b>	<b>21-23</b>
<b>LIGHT TRUCK GVWR RATING .....</b>	<b>24</b>
<b>WRECKER TOWING FORD VEHICLES WITH AIR BAGS .....</b>	<b>25</b>
<b>LIGHT TRUCK TOWING</b>	
Freestyle.....	26-27
Edge, MKX .....	28-29
Freestar, Monterey.....	30
Explorer, Mountaineer, Sport-Trac .....	31-32
Ranger .....	33-34
F-150, Navigator, Expedition, Mark LT .....	35-36
F-Super Duty (F-250, F-350, F-450, F-550) .....	37-38
Escape, Mariner, Escape Hybrid, Mariner Hybrid .....	39-40
E-Series, Club Wagon, E-150, E-250, E-350, E-450 .....	41-42
E-Series H2 ICE .....	43-44
<b>2007 FORD SERVICE INFORMATION .....</b>	<b>45</b>

# TOWING EQUIPMENT

## SLINGBELT

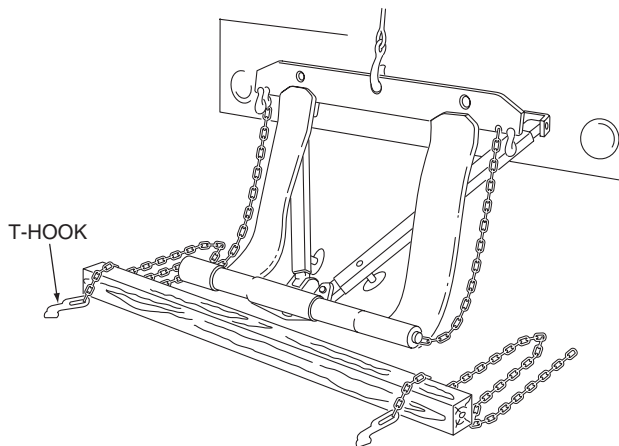

## CROSSBEAM/SPACER BLOCKS

MATERIAL – CROSSBEAMS

ONE – 4x4x60" LONG – ONE 4x4x48" LONG

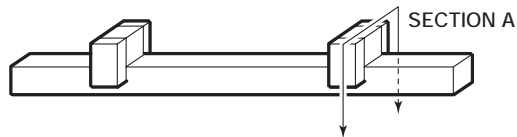

SPACER BLOCKS CAN BE  
FABRICATED AS SHOWN.

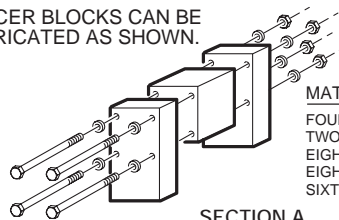

MATERIAL-SPACER BLOCKS

FOUR – 2x4x6" LONG

TWO – 2x4x3-1/2" LONG

EIGHT – 1/4x7" CARRIAGE BOLT

EIGHT – 1/4" NUT

SIXTEEN – 1/4" WASHER

SECTION A

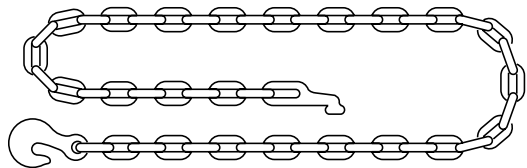

## CROSSBEAM/WITHOUT SPACER BLOCKS



MATERIAL – CROSSBEAMS

2 – 4x4x60" LONG    2 – 4x4x48" LONG

# GENERAL TOWING INFORMATION — PASSENGER CARS

## IMPORTANT SAFETY NOTICE

### NOTES AND CAUTIONS

**As you read through the procedures, you will come across NOTES and CAUTIONS. Each one is there for a specific purpose. NOTES give you added information that will help to complete a particular procedure. CAUTIONS are given to prevent you from making an error that could damage the vehicle.**

### Preparatory Steps

Release the parking brake and place transmission/transaxle in NEUTRAL. As a general rule, vehicles should be towed with the drive wheels off the ground. If the vehicle is to be towed on its drive wheels, the transmission/transaxle and differential must be operable. If the transmission/transaxle is not operable, place the drive wheels on a dolly or disconnect the rear driveshaft on rear wheel drive vehicles. **DO NOT** disconnect the driveshaft on Mustang; refer to the caution in the Mustang portion of this manual. If the differential is not operable, place the drive wheels on a dolly.

When a vehicle is towed on its front wheels, the steering wheel must be clamped in the straight ahead position with a steering wheel clamping device designed for towing service use, such as those provided by towing system manufacturers.

Do not use the vehicle's steering column lock to lock the wheels in a straight ahead position when towed from the front or rear. If the ignition key is not available, place a dolly underneath the driving wheels of the vehicle and tow with the non-drive wheels raised.

### Brake-Shift Interlock

All Ford, Lincoln and Mercury vehicles, equipped with an automatic transmission/transaxle, incorporate a brake-shift interlock feature that prevents the gearshift lever from being moved from PARK when the ignition is in the ON position, unless the brake pedal is depressed. If you cannot move the gearshift lever out of PARK with the ignition in the ON position and the brake pedal depressed, refer to the automatic transmission or transaxle section in the driving section of the applicable Owner Guide.

### Flatbeds

When using a flatbed to transport a vehicle, unless indicated otherwise, use T-hooks inserted in the appropriate tie down slot. Never fasten J-hooks to any suspension wheel or driveline component because J-hooks will damage these components. When using winches, take care to avoid damaging the bumper system, lower body panels or air dams.

On vehicles equipped with an air suspension system, be sure the air suspension service switch is turned off prior to vehicle tie down.

**CAUTION: Improperly tying down a disabled vehicle may damage the vehicle's suspension, driveline or body parts.**

### Wheel Lift

**CAUTION: When towing over very rough or crowned intersection roads, the following special procedures are required when using any wheel lift equipment. The vehicle must be secured to the wheel lift equipment using safety chains equipped with T-hooks or safety hooks. If these procedures are not followed, damage to the underbody may result from excessive jounce travel of the suspension.**

# GENERAL TOWING INFORMATION — PASSENGER CARS

1. Attach the safety chain T-hooks in the appropriate slot of the body or frame of the vehicle to be towed.
2. Run the chain through the hooks on the wheel lift crossbar and attach it to the towing vehicle.
3. For all vehicles except the Five Hundred and Montego, make sure that there is no slack in the safety chain between the vehicle to be towed and the crossbar.
4. Repeat steps 1 and 2 for the other side of the vehicle.

**NOTE:** Check vehicles specifications for raised vehicle height requirements.

## **Slingbelts**

Slingbelts may only be used when indicated in the towing procedure for a specific vehicle. When attaching slingbelts, take care to avoid damage to the license plate, fog lamps, etc., if equipped. Using a slingbelt when not indicated may cause damage to the bumper system, lower body panels or air dams.

## **Towing Speeds**

See specific model instructions for vehicle towing speed and distance limitations.

UNLTD = Unlimited speed (50 mph/80 km/h) or mileage.

**On rough pavement, the maximum towing speed is 35 mph (56 km/h). Maximum towing speed of 35 mph (56 km/h) should be used whenever the tow truck operator is not sure of road surface condition.**

**Refer to the dolly manufacturer for speed and weight limitations.**

# WRECKER TOWING FORD VEHICLES WITH AIR BAGS

## General Information

An air bag is highly unlikely to deploy during wrecker towing. Standard wrecker towing or recovery procedures on an air bag equipped vehicle should not cause air bag deployment. Only a significant frontal or side (if equipped with side air bags) impact that closes two crash sensors will deploy an air bag.

## How to Determine if a Ford Vehicle has Air Bags

- The fourth position of all Ford passenger car VINs is the letter:
  - “F” if equipped with active belts at all designated seating positions plus driver and passenger air bags.
  - “H” if equipped with active belts at all designated seating positions, driver and passenger air bags, plus driver and passenger side air bags, curtains, or canopies.
- The steering wheel hub will also be larger and more rectangular (about 6 in x 9 in). The passenger-side air bag module trim covers will be molded with “SRS” or “AIRBAG”.
- The VIN plate may have “AIR BAG” printed on it.

## Is it Necessary to Disable the Air Bag System for Wrecker Towing?

- Disabling the air bag system is **not** necessary in most cases. But, as a precaution, disconnect the battery ground (-) cable in a safe manner when the vehicle has significant damage to the front of the vehicle and an undeployed air bag.

NOTE: Turning the ignition switch to OFF may **not** disable the Ford air bag system. Some older model air bag deployment systems operate independently of the ignition key position.

## Wrecker Towing a Vehicle with Deployed Air Bags

- Deployed air bags are **not** dangerous.
- Any powdery residue consists of corn starch or talcum powder and sodium compounds, mostly sodium carbonates (e.g., baking soda) accompanied by very minute deposits of sodium hydroxide that can be irritating to the skin and eyes but poses no long term health hazard.

# TAURUS

## FRONT TOWING CONNECTIONS

**CAUTION:** Use care not to damage fog lamps on vehicles, if equipped.



**CAUTION:** It is recommended that the Taurus be towed with a wheel lift or flatbed equipment. Do not tow with a slingbelt. Ford Motor Company has not approved a slingbelt towing procedure. If the vehicle is towed by other means or incorrectly, vehicle damage may occur.

**NOTE:** Refer to general towing information on pages 5 and 6 before towing vehicle.

TRANS	MPH/KMH	MILES/KMS
AUTO	UNLTD	UNLTD

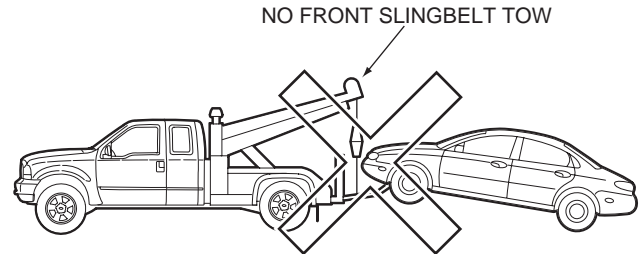
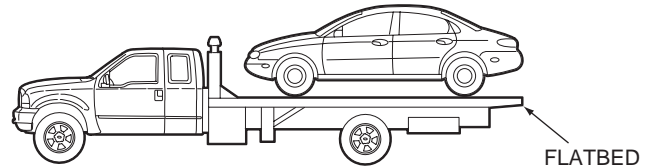
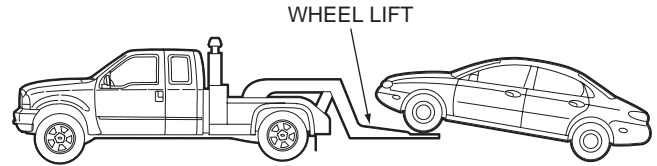



TRANS	MPH/KMH	MILES/KMS
AUTO without Dolly	35/56	50/80
AUTO with Dolly	UNLTD	UNLTD

# TAURUS

## REAR TOWING CONNECTIONS

**CAUTION:** If the Taurus is to be towed from the rear using wheel lift equipment, it is recommended that the front wheels (drive wheels) be placed on a dolly to prevent damage to the transaxle.



**CAUTION:** Do not use shipping slots on bumper brackets for towing.

**CAUTION:** It is recommended that the Taurus be towed with a wheel lift or flatbed equipment. Do not tow with a slingbelt. Ford Motor Company has not approved a slingbelt towing procedure. If the vehicle is towed by other means or incorrectly, vehicle damage may occur.

**NOTE:** Refer to general towing information on pages 5 and 6 before towing vehicle.

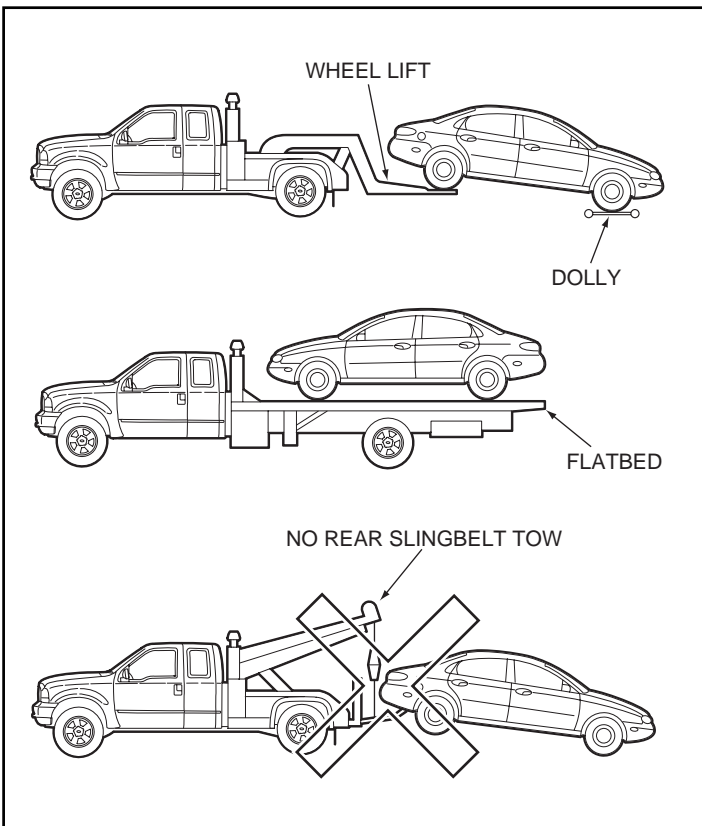

# FOCUS

## FRONT TOWING CONNECTIONS

**CAUTION:** It is recommended that the Focus be towed with a wheel lift or flatbed equipment. Do not tow with a slingbelt. Ford Motor Company has not approved a slingbelt towing procedure. If the vehicle is towed from the front by other means or incorrectly, vehicle damage may occur.



**CAUTION:** When the Focus is towed over very rough, pitching roads such as a crowned road intersection at a railroad crossing, towing should be greatly reduced to avoid damaging the vehicle undercarriage.

**NOTE:** Refer to general towing information on pages 5 and 6 before towing vehicle.

TRANS	MPH/KMH	MILES/KMS
AUTO	UNLTD	UNLTD
MANUAL	UNLTD	UNLTD

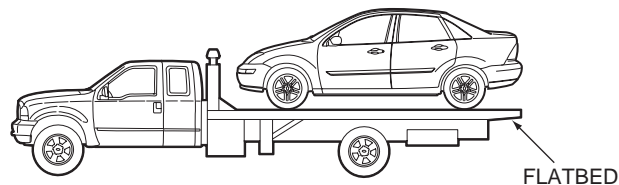
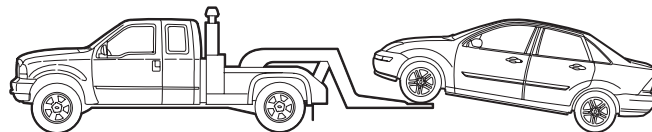

NO FRONT SLINGBELT TOW

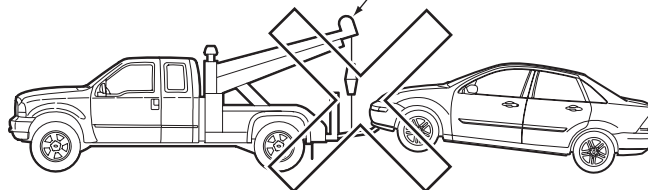

TRANS	MPH/KMH	MILES/KMS
AUTO	UNLTD	UNLTD
MANUAL	UNLTD	UNLTD

## FOCUS

### REAR TOWING CONNECTIONS

**CAUTION:** If the vehicle is to be towed from the rear using wheel lift equipment, the front wheels (drive wheels) must be placed on a dolly to prevent damage to the transaxle.



**CAUTION:** It is recommended that the Focus be towed with a wheel lift or flatbed equipment. Do not tow with a slingbelt. Ford Motor Company has not approved a slingbelt towing procedure. If the vehicle is towed by other means or incorrectly, vehicle damage may occur.

**NOTE:** Refer to general towing information on pages 5 and 6 before towing vehicle.

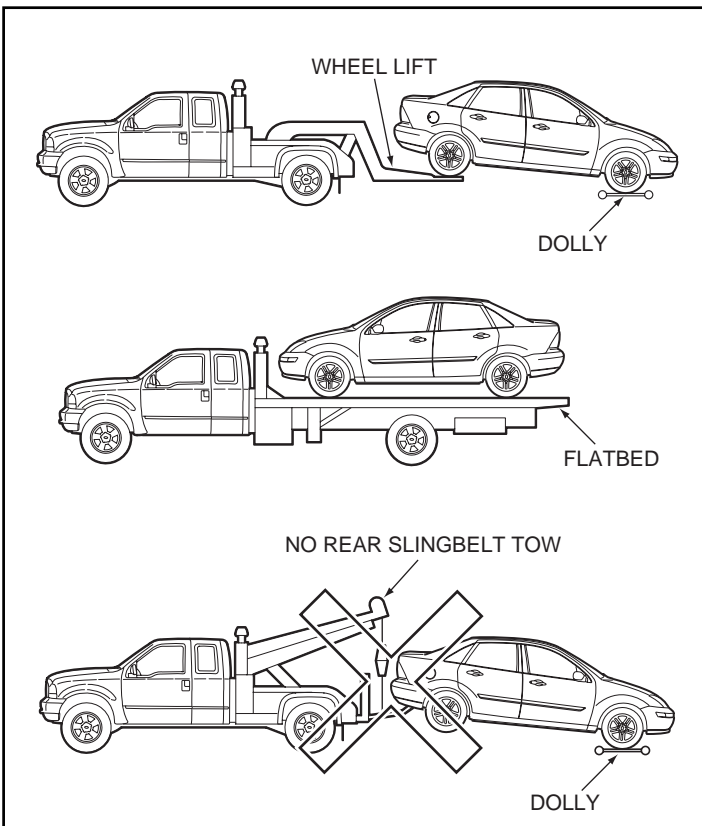

## TOWN CAR, CROWN VICTORIA, GRAND MARQUIS

### FRONT TOWING CONNECTIONS

**WARNING: ON VEHICLES EQUIPPED WITH THE FIRE SUPPRESSION SYSTEM, COMPLETE ALL PRE-TOWING, UNDER-VEHICLE ACTIVITY (SECURING VEHICLE, CHAINS, STRAPS, ETC.) BEFORE TURNING THE KEY TO THE RUN POSITION. THE FIRE SUPPRESSION SYSTEM IS ACTIVE WHENEVER THE KEY IS IN THE RUN POSITION AND WILL DEPLOY IF THE MANUAL ACTIVATION BUTTON IS DEPRESSED.**



**CAUTION:** Before the vehicle can be towed, the air suspension control in the luggage compartment must be turned to the OFF position (if equipped).

**CAUTION:** It is recommended that the Town Car, Crown Victoria and Grand Marquis be towed with a wheel lift or flatbed equipment. Do not tow with a slingbelt. Ford Motor Company has not approved a slingbelt towing procedure. If the vehicle is towed by other means or incorrectly, vehicle damage may occur.

**CAUTION:** On vehicles with air suspension – if the rear air bags are deflated, load the vehicle on a flatbed and use a 4x4 board under the bed to lift the rear of the vehicle so that the rear bumper will not drag on the road surface.

**NOTE:** Refer to general towing information on pages 5 and 6 before towing vehicle.

TRANS	MPH/KMH	MILES/KMS
AUTO	35/56	50/80

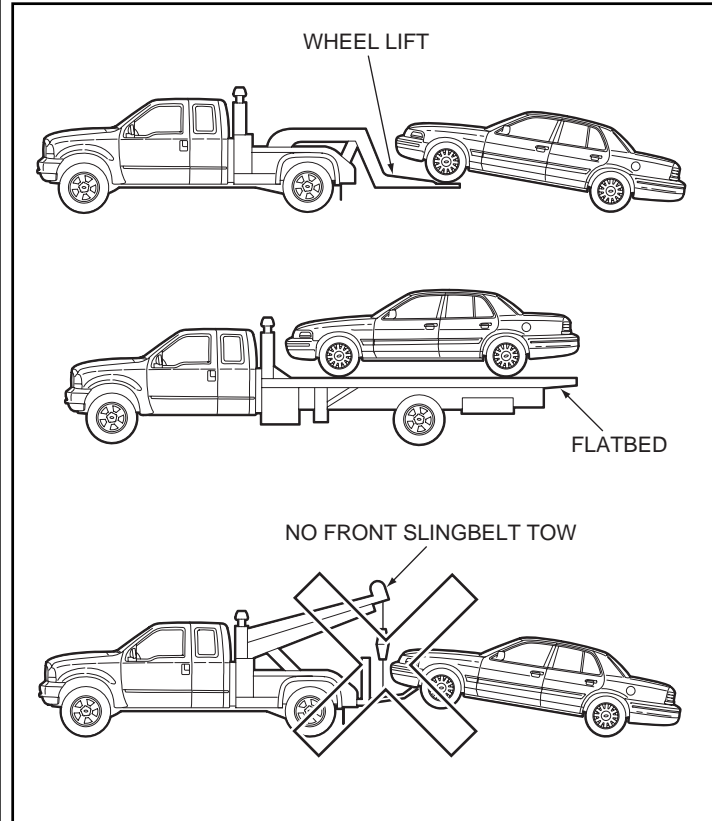

TRANS

MPH/KMH

MILES/KMS

AUTO

UNLTD

UNLTD

**TOWN CAR, CROWN VICTORIA, GRAND MARQUIS**

**REAR TOWING CONNECTIONS**

**WARNING: ON VEHICLES EQUIPPED WITH THE FIRE SUPPRESSION SYSTEM, COMPLETE ALL PRE-TOWING, UNDER-VEHICLE ACTIVITY (SECURING VEHICLE, CHAINS, STRAPS, ETC.) BEFORE TURNING THE KEY TO THE RUN POSITION. THE FIRE SUPPRESSION SYSTEM IS ACTIVE WHENEVER THE KEY IS IN THE RUN POSITION AND WILL DEPLOY IF THE MANUAL ACTIVATION BUTTON IS DEPRESSED.**



**CAUTION: Before the vehicle can be towed, the air suspension control in the luggage compartment must be turned to the OFF position (if equipped).**

**CAUTION: It is recommended that the Town Car, Crown Victoria and Grand Marquis be towed with a wheel lift or flatbed equipment. Do not tow with a slingbelt. Ford Motor Company has not approved a slingbelt towing procedure. If the vehicle is towed by other means or incorrectly, vehicle damage may occur.**

**CAUTION: On vehicles with air suspension – if the rear air bags are deflated, load the vehicle on a flatbed and use a 4x4 board under the bed to lift the rear of the vehicle so that the rear bumper will not drag on the road surface.**

**NOTE: Refer to general towing information on pages 5 and 6 before towing vehicle.**

WHEEL LIFT

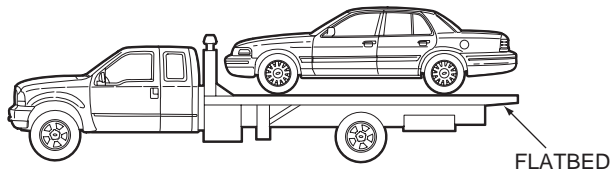
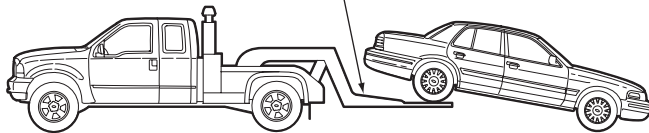

NO REAR SLINGBELT TOW

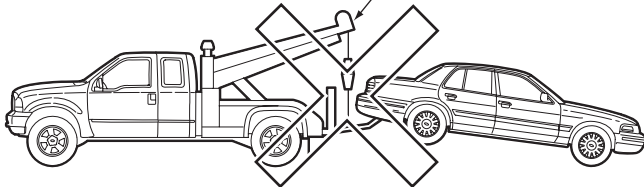

# MUSTANG, SHELBY GT500

## FRONT AND REAR TOWING CONNECTIONS

**CAUTION:** Do not disconnect the driveshaft since the system is aligned and balanced.

**CAUTION:** Manual transmission vehicles **MUST** have the parking brake fully engaged when the rear wheels are on the dolly. 

### V6 COUPE AND CONVERTIBLE WHEEL LIFT TOWING

**CAUTION:** If the Mustang is to be towed from the front using wheel lift equipment, the front wheels must be raised to a minimum height of 18 in (46 cm) **ABOVE** the non-raised wheels to prevent damage to the vehicle undercarriage.

**CAUTION:** If the Mustang is to be towed from the rear using wheel lift equipment, the rear wheels must be raised to a minimum height of 14 in (36 cm) **ABOVE** the non-raised wheels to prevent damage to the vehicle undercarriage.

**CAUTION:** If the vehicle is towed from the rear without using tow dollies for the front tires, damage to the front fascia may occur.

### V8 COUPE, SHELBY GT500 AND CONVERTIBLE WHEEL LIFT TOWING

**CAUTION:** If the Mustang is to be towed from the front using wheel lift equipment, the front wheels must be raised to a minimum height of 16 in (41 cm) **ABOVE** the non-raised wheels to prevent damage to the vehicle undercarriage.

**CAUTION:** If the vehicle is towed from the front without using tow dollies for the rear tires, damage to the rear fascia may occur.

**CAUTION:** If the Mustang is to be towed from the rear using wheel lift equipment, the rear wheels must be raised to a minimum height of 14 in (36 cm) **ABOVE** the non-raised wheels to prevent damage to the vehicle undercarriage.

**CAUTION:** If the vehicle is towed from the rear without using tow dollies for the front tires, damage to the front fascia may occur.

**CAUTION:** It is recommended that the Mustang be towed with wheel lift or flatbed equipment only. Do not tow with a slingbelt. Ford Motor Company has not approved a slingbelt towing procedure. If the vehicle is towed by other means or incorrectly, vehicle damage may occur.

**NOTE:** Refer to general towing information on pages 5 and 6 before towing vehicle.

TRANS	MPH/KMH	MILES/KMS
AUTO	UNLTD	UNLTD
MANUAL	UNLTD	UNLTD

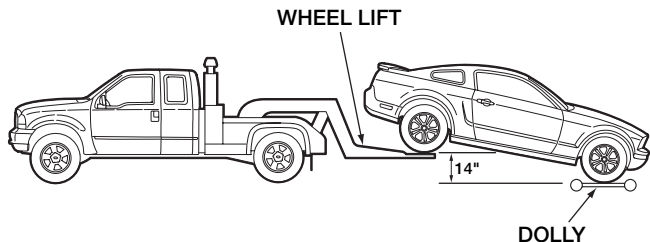
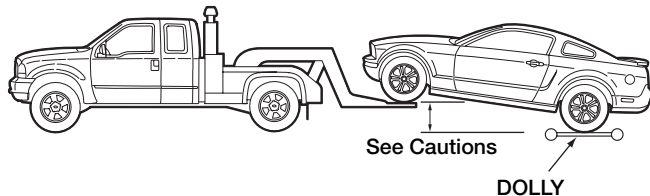

### NO FRONT OR REAR SLINGBELT TOW

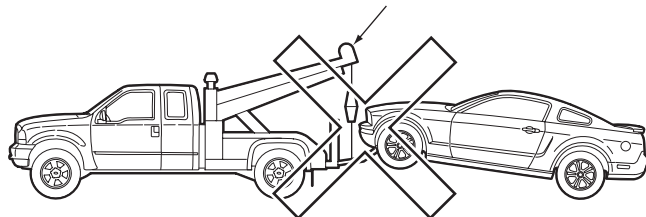

TRANS	MPH/KMH	MILES/KMS
AUTO	UNLTD	UNLTD
MANUAL	UNLTD	UNLTD

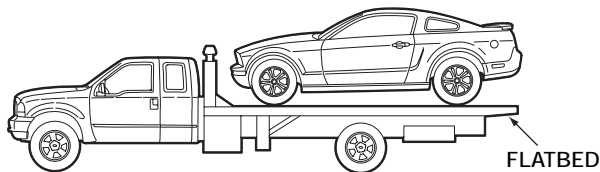
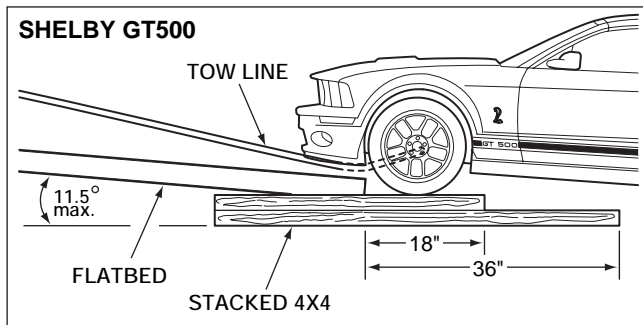
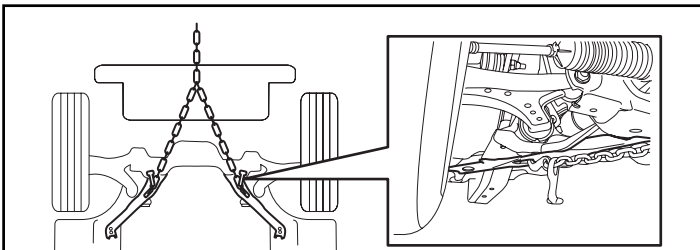

## MUSTANG, SHELBY GT500

### FLATBED TOWING

**CAUTION:** Do not disconnect the driveshaft since the system is aligned and balanced.

**CAUTION:** It is recommended that the vehicle be loaded onto a flatbed tow truck with the tow hook attached to a canvas strap, to prevent damage to the bottom of the front or rear bumper covers. If a strap is not available, wrap the tow cable/chain with a cloth.



**CAUTION:** It is recommended when using a flatbed, use mini J-hooks to tie down the front of the vehicle.

**NOTE:** Two rear tie-down devices should be attached with T-hooks in the shipping slots located in the rockers inward and forward of the rear wheels.

#### Flatbed Towing Procedure – SHELBY GT500

- Stack one long and one short 4x4 wood block per side (or other suitable ramping used to reduce the approach angle of the bed to 11.5 degrees and get the nose of the vehicle on the bed).
- Lower the carrier deck to hold ramps in place. Upper 4x4 should extend 18 in (45.72 cm) behind the carrier ramp. Lower 4x4 should extend 36 in (91 cm) behind the carrier ramp.
- Attach the tow hooks.
- Transport the vehicle with the parking brake OFF and the transmission in NEUTRAL.

**NOTE:** Two rear tie-down devices should be attached with T-hooks in the shipping slots located in the rockers inward and forward of the rear wheels.

**NOTE:** Inspect tie-downs periodically for tightness.

**NOTE:** Refer to general towing information on pages 5 and 6 before towing vehicle.

# FUSION, MILAN, MKZ

## FRONT TOWING CONNECTIONS

**CAUTION:** Use care not to damage fog lamps on vehicles, if equipped.



**CAUTION:** It is required that the Fusion, Milan and MKZ be towed with wheel lift equipment and dollies or flatbed equipment. Do not tow with a slingbelt. Ford Motor Company has not approved a slingbelt towing procedure. If the vehicle is towed by other means or incorrectly, vehicle damage may occur.

**CAUTION:** If the Fusion, Milan and MKZ is to be towed from the front using wheel lift equipment, it is required that the rear wheels be placed on a dolly to prevent damage to the vehicle's rear bumper or powertrain if equipped with all wheel drive (AWD).

**CAUTION:** If the Fusion, Milan and MKZ are to be towed from the front using wheel lift equipment, the front wheels must be raised to a height of 19 inches (48 cm) **ABOVE** the dollies to prevent damage to the vehicle undercarriage.

**NOTE:** Using safety hooks, safety chains should be attached to the front corners of the subframe.

**NOTE:** Refer to general towing information on pages 5 and 6 before towing vehicle.

TRANS	MPH/KMH	MILES/KMS
AUTO without Dolly	35/56	50/80
AUTO with Dolly	UNLTD	UNLTD

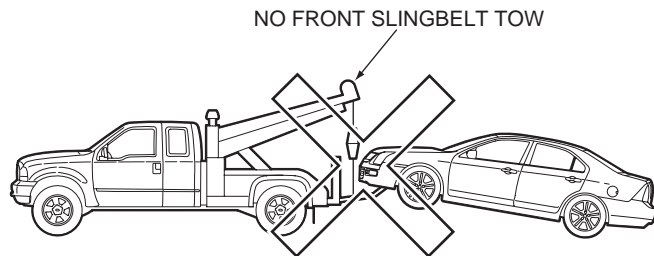
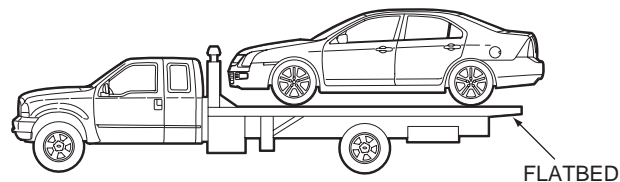
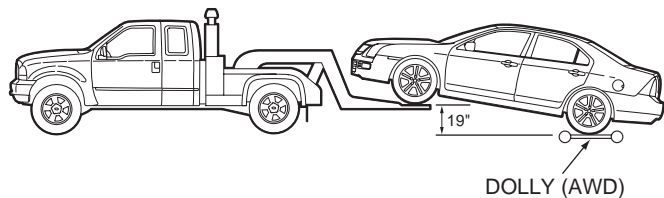



TRANS	MPH/KMH	MILES/KMS
AUTO	UNLTD	UNLTD

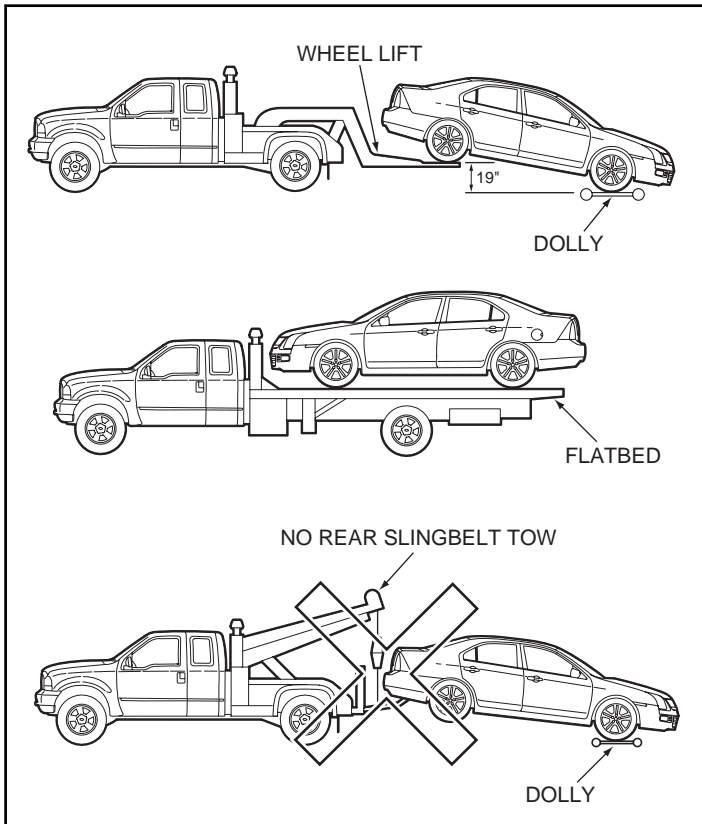

## FUSION, MILAN, MKZ

### REAR TOWING CONNECTIONS

**CAUTION:** If the Fusion, Milan and MKZ are to be towed from the rear using wheel lift equipment, it is required that the front wheels (drive wheels) be placed on a dolly to prevent damage to the transaxle and the vehicle.



**CAUTION:** It is required that the Fusion, Milan and MKZ are towed with wheel lift equipment and dollies or flatbed equipment. Do not tow with a slingbelt. Ford Motor Company has not approved a slingbelt towing procedure. If the vehicle is towed by other means or incorrectly, vehicle damage may occur.

**CAUTION:** If the Fusion, Milan and MKZ are to be towed from the rear using wheel lift equipment, the rear wheels must be raised to a height of 19 inches (48 cm) ABOVE the dollies to prevent damage to the vehicle undercarriage.

**NOTE:** Safety chains should be attached in the T-hook slots located on the underside of the rocker panels forward of the rear wheels.

**NOTE:** Refer to general towing information on pages 5 and 6 before towing vehicle.

# FIVE HUNDRED, MONTEGO

## FRONT TOWING CONNECTIONS

**CAUTION:** Use care not to damage fog lamps on vehicles, if equipped.



**CAUTION:** It is required that the Five Hundred and Montego be towed with a wheel lift or flatbed equipment. Do not tow with a slingbelt. Ford Motor Company has not approved a slingbelt towing procedure. If the vehicle is towed by other means or incorrectly, vehicle damage may occur.

**CAUTION:** If the Five Hundred or Montego is to be towed from the front using wheel lift equipment, it is required that the rear wheels be placed on a dolly to prevent damage to the vehicle's rear bumper and AWD system (if equipped).

**CAUTION:** If the Five Hundred or Montego is to be towed from the front using wheel lift equipment, the front wheels must be raised to a height of 12 in (30 cm) ABOVE the rear wheels to prevent damage to the vehicle undercarriage.

**CAUTION:** If the Five Hundred or Montego is equipped with AWD, it is required to tow the vehicle with all wheels off the ground. Use wheel lift equipment and a dolly or a flatbed transport vehicle to prevent damage to the AWD system.

**NOTE:** Safety chains should be attached in the T-hook slots located on the underside of the rocker panels rearward of the front wheels.

**NOTE:** Refer to general towing information on pages 5 and 6 before towing vehicle.

TRANS	MPH/KMH	MILES/KMS
FWD	UNLTD	UNLTD
AWD with Dolly	UNLTD	UNLTD

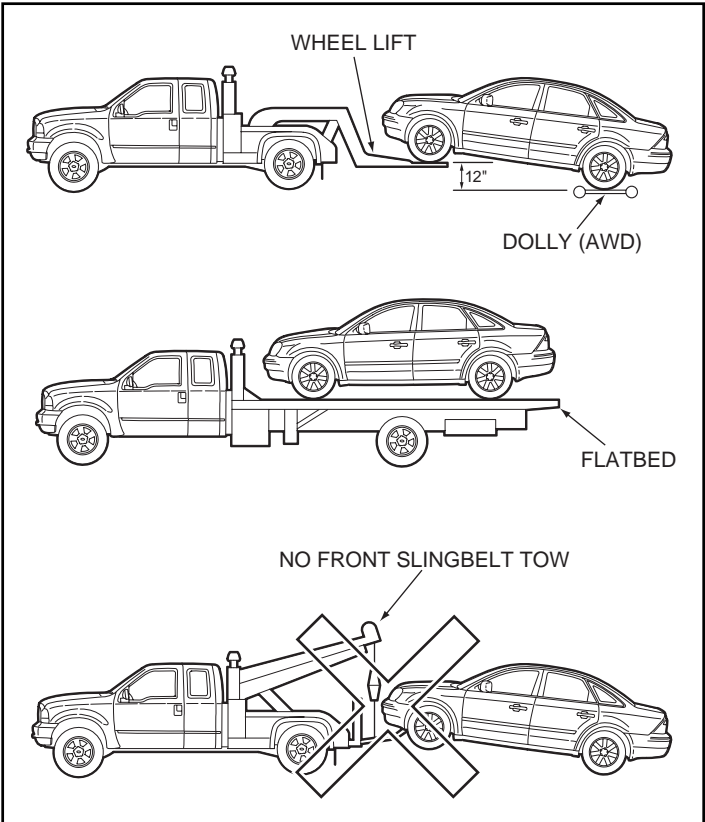

TRANS	MPH/KMH	MILES/KMS
FWD with Dolly	UNLTD	UNLTD
AWD with Dolly	UNLTD	UNLTD

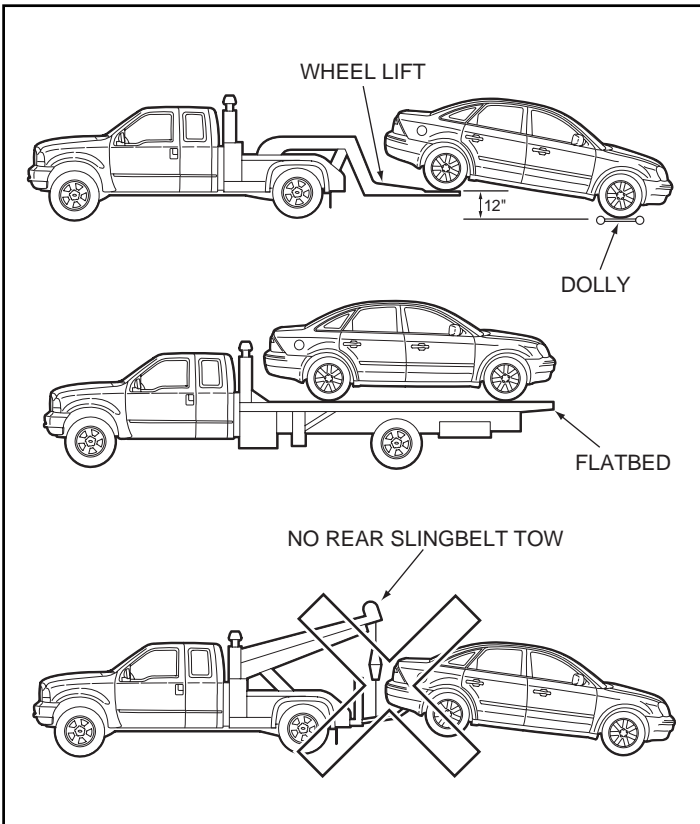

## FIVE HUNDRED, MONTEGO

### REAR TOWING CONNECTIONS

**CAUTION:** If the Five Hundred or Montego is to be towed from the rear using wheel lift equipment, it is required that the front wheels (drive wheels) be placed on a dolly to prevent damage to the transaxle and the vehicle.



**CAUTION:** It is required that the Five Hundred or Montego is towed with wheel lift or flatbed equipment. Do not tow with a slingbelt. Ford Motor Company has not approved a slingbelt towing procedure. If the vehicle is towed by other means or incorrectly, vehicle damage may occur.

**CAUTION:** If the Five Hundred or Montego is to be towed from the rear using wheel lift equipment, the rear wheels must be raised to a height of 12 in (30 cm) ABOVE the front wheels to prevent damage to the vehicle undercarriage.

**NOTE:** Safety chains should be attached in the T-hook slots located on the underside of the rocker panels forward of the rear wheels.

**NOTE:** Refer to general towing information on pages 5 and 6 before towing vehicle.

**PAGE LEFT BLANK INTENTIONALLY**

# GENERAL TOWING INFORMATION — LIGHT TRUCKS

## IMPORTANT SAFETY NOTICE

### NOTES AND CAUTIONS

As you read through the procedures, you will come across **NOTES** and **CAUTIONS**. Each one is there for a specific purpose. **NOTES** give you added information that will help to complete a particular procedure. **CAUTIONS** are given to prevent you from making an error that could damage the vehicle.

### Preparatory Steps

Release the parking brake and place the transmission/transaxle in NEUTRAL. As a general rule, vehicles should be towed with the drive wheels off the ground. If the vehicle is to be towed on its drive wheels, the transmission/transaxle and differential must be operable. If the transmission/transaxle is not operable, place the drive wheels on a dolly or disconnect the rear driveshaft (on rear wheel drive vehicles). If the differential is not operable, place the drive wheels on a dolly.

When a vehicle is towed on its front wheels, the steering wheel must be clamped in the straight ahead position with a steering wheel clamping device designed for towing service use, such as those provided by towing system manufacturers.

Do not use the vehicle's steering column lock to lock the wheels in a straight ahead position when pulled from the rear. If the ignition key is not available, place a dolly underneath the drive wheels of the vehicle and tow with the non-drive wheels raised.

### Brake-Shift Interlock

All Ford, Lincoln and Mercury vehicles, equipped with an automatic transmission/transaxle, incorporate a brake-shift interlock feature that prevents the gearshift lever from being moved from PARK when the ignition is in the ON position unless the brake pedal is depressed. If you cannot move the gearshift lever out of PARK with the ignition in the ON position and the brake pedal depressed, refer to the automatic transmission or transaxle section in the driving section of the applicable Owner Guide.

**WARNING: DO NOT TOW VEHICLE BACKWARD WHEN TOWING THE VEHICLE WITH ALL FOUR WHEELS ON THE GROUND.**

When towing the vehicle with all four wheels on the ground, the steering wheel should be left unlocked.

**CAUTION: Improper towing of the vehicle could result in transmission/transaxle and/or transfer case damage. Always follow the outlined towing procedures. It is recommended that only an unloaded vehicle be towed.**

**IF TOWING WITH A LOAD IS UNAVOIDABLE, CARE MUST BE TAKEN TO PROPERLY RESTRAIN LOAD FROM SHIFTING AND DISTRIBUTE THE LOAD EVENLY IN THE PICKUP BOX.**

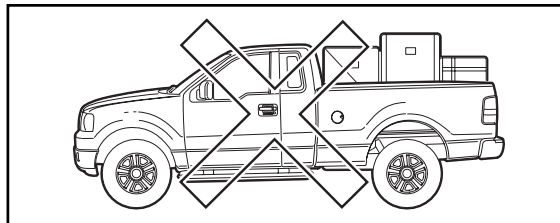

# GENERAL TOWING INFORMATION — LIGHT TRUCKS

## Towing Four-Wheel Drive Vehicles with Lever-Operated Transfer Case – F-150, F-250 through F-550

1. Place the automatic transmission in PARK or manual transmission in 1st gear.
2. Place the transfer case in N (NEUTRAL).

**NOTE:** The transfer case NEUTRAL setting is located between 4H and 4L. In order to place the transfer case in NEUTRAL, the lever must be moved slightly to the left and rearward of the 4H position. With the ignition in the ON position, both the 4x4 and LOW RANGE indicators will be OFF when the transfer case is in NEUTRAL. If the battery is dead, jump the vehicle to make sure the lights are off.

3. On a F-Super Duty, set the manual locking hubs to the FREE position.

**NOTE:** To verify that the hubs are in the FREE position, the front driveshaft should turn freely.

Towing speed should not exceed 50 mph (80 km/h). This applies with either the front or rear wheels off the ground.

## Towing Four-Wheel Drive Vehicles with Electronic Shift Transfer Case – F-150, F-250 through F-550, Ranger and Sport-Trac

1. Place the automatic transmission in PARK or manual transmission in 1st gear.

**NOTE:** With the ignition in the ON position, both the 4x4 HI and the LOW RANGE indicators will be OFF when the transfer case is in 2 HI. If the battery is dead, jump the vehicle to make sure the lights are off.

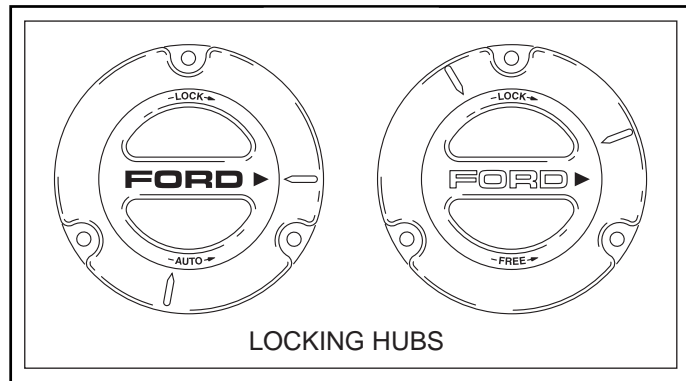

2. Set the locking hubs to the AUTO position.

**NOTE:** Manual locking hubs apply to F-250 through F-550 only.

Once these 2 conditions are met, follow the instructions for towing a two-wheel drive vehicle.

**WARNING: NEVER USE A TOW BAR THAT ATTACHES TO THE BUMPER WHEN TOWING THE VEHICLE. THE BUMPER COULD BE DAMAGED AND CAUSE AN ACCIDENT.**

**NOTE:** If a distance of 50 miles (80 km) and/or a speed of 35 mph (55 km/h) is exceeded, or when the vehicle is towed with the drive wheels on the ground, either position dollies under the wheels, or disconnect the driveshaft. Towing speed should not exceed 50 mph (80 km/h), when the vehicle is towed with the wheels off the ground. Do not tow with both front wheels on the ground.

# GENERAL TOWING INFORMATION — LIGHT TRUCKS

## Flatbeds

**CAUTION: Improperly tying down a disabled vehicle may damage the vehicle's suspension, driveline or body parts.**

## Wheel Lift

**CAUTION: When towing over very rough or crowned intersection roads, the following special procedures are required when using any wheel lift equipment. The vehicle must be secured to the wheel lift equipment using safety chains equipped with T-hooks. If this procedure is not followed, damage to the underbody may result from excessive jounce travel of the suspension.**

1. Attach the safety chain T-hooks in the appropriate slot of the body or frame of the vehicle to be towed.
2. Run the chain through the hooks on the wheel lift crossbar and attach it to the towing vehicle.
3. For all vehicles except Freestyle, make sure that there is no slack in the safety chain between the vehicle to be towed and the crossbar.
4. Repeat steps 1 and 2 for the other side of the vehicle.

**NOTE:** Check vehicles' specifications for raised vehicle height requirements.

## Slingbelts/Chains/Hooks

Slingbelts may only be used when indicated in the towing procedure for a specific vehicle. When attaching slingbelts, take care to avoid damage to the license plate, fog lamps, etc., if equipped. Using a slingbelt when not indicated may cause damage to the bumper system, lower body panels or air dams.

**CAUTION: Use caution when attaching tow hooks and safety chains to vehicle. Position and remove hooks with care to avoid damage to brake hoses, brake lines and steering linkage components.**

**NOTE:** On vehicles equipped with bumper guards, make sure the slingbelt towbar is under the bumper and the weight of the vehicle is not supported by the bumper guards.

## Towing Speeds

See specific model instructions for vehicle towing speed and distance limitations.

UNLTD = Unlimited speed (50 mph/80 km/h) or mileage.

**On rough pavement, the maximum towing speed is 35 mph (55 km/h). Maximum towing speed of 35 mph (55 km/h) should be used whenever the tow truck operator is not sure of road surface conditions.**

**Refer to the dolly manufacturer for speed and weight limitations.**

**NOTE:** For towing or operating conditions other than what is prescribed in this manual, the driveshaft must be removed to prevent driveline damage. Always mark the location of the driveshaft to the attaching flange before removal so the shaft can be properly indexed upon installation. Driveshaft attachment bolts must be replaced with the new OEM bolts.

# LIGHT TRUCK GVWR RATING

Vehicle line	VIN code 4th digit	GVWR	
		Kilograms (kg)	Pounds (lbs)
Escape/Escape Hybrid	C	1,814 - 2,268	4,001 - 5,000
Mariner/Mariner Hybrid	Y	1,814 - 2,268	4,001 - 5,000
E-Series	N	3,856 - 4,082	8,501 - 9,000
	S	4,083 - 4,535	9,001 - 10,000
	W	4,536 - 6,350	10,001 - 14,000
	X	6,351 - 7,257	14,001 - 16,000
	A	7,258 - 8,845	16,001 - 19,500
	H	3,856 - 4,082	8,501 - 9,000
	J	4,083 - 4,535	9,001 - 10,000
	K	4,536 - 6,350	10,001 - 14,000
	L	6,351 - 7,257	14,001 - 16,000
F-Super Duty 250 - 550	N	3,855 - 4,082	8,501 - 9,000
	S	4,083 - 4,535	9,001 - 10,000
	W	4,536 - 6,350	10,001 - 14,000
	X	6,351 - 7,257	14,001 - 16,000
	A	7,258 - 8,845	16,001 - 19,500
Expedition	F	3,175 - 3,629	7,001 - 8,000
Navigator	P	3,175 - 3,629	7,001 - 8,000
Explorer/Mountaineer	E	2,722 - 3,175	6,001 - 7,000
Explorer Sport Trac	R	2,722 - 3,175	6,001 - 7,000
	E	2,722 - 3,175	6,001 - 7,000

Vehicle line	VIN code 4th digit	GVWR	
		Kilograms (kg)	Pounds (lbs)
F-150	V	3,630 - 3,855	8,001 - 8,500
Mark LT	R	2,722 - 3,175	6,001 - 7,000
	P	3,176 - 3,628	7,001 - 8,000
Ranger	Y	1,814 - 2,268	4,001 - 5,000
	Z	2,269 - 2,721	5,001 - 6,000
Freestar	Z	2,269 - 2,721	5,001 - 6,000
Monterey	D	2,269 - 2,721	5,001 - 6,000
Freestyle	Z	2,269 - 2,721	5,001 - 6,000
	D	2,269 - 2,721	5,001 - 6,000
Edge	TBD	TBD	TBD
MKX	TBD	TBD	TBD



# WRECKER TOWING FORD VEHICLES WITH AIR BAGS

## General Information

An air bag is highly unlikely to deploy during wrecker towing. Standard wrecker towing or recovery procedures on an air bag equipped vehicle should not cause air bag deployment. Only a significant frontal impact that closes two crash sensors will deploy an air bag.

## How to Determine if a Ford Vehicle has Air Bags

- The fourth position of all Ford light truck VINs is the letter:
  - “A, N, P, R, S, T, U, V, W, X, Y or Z” if equipped with driver and passenger air bags.
  - “B, C, D, E, F, N or S” if equipped with driver and passenger air bags, plus driver and passenger side air bags, curtains or canopies.
  - “H, J, K, L or M” if **not** equipped with air bags.
- The steering wheel hub will also be larger and more rectangular (about 6 in x 9 in). The passenger-side air bag module trim covers will be moulded with “SRS”.

## Is it Necessary to Disable the Air Bag System for Wrecker Towing?

- Disabling the air bag system is **not** necessary in most cases.
- As a precaution, disconnect the battery in a safe manner when the vehicle has significant damage to the front of the vehicle and an undeployed air bag.

**NOTE:** Turning the ignition switch to OFF will **not** disable the Ford air bag system. The air bag deployment system operates independently of the ignition key position.

## Wrecker Towing a Vehicle with Deployed Air Bags

- Deployed air bags are **not** dangerous.
- Any powdery residue consists of corn starch or talcum powder and sodium compounds, mostly sodium carbonates (e.g., baking soda) accompanied by very minute deposits of sodium hydroxide that can be irritating to the skin and eyes but poses no long-term health hazard.

# FREESTYLE

## FRONT TOWING CONNECTIONS

**CAUTION:** Use care not to damage fog lamps on vehicles, if equipped.



**CAUTION:** It is required that the Freestyle be towed with a wheel lift or flatbed equipment. Do not tow with a slingbelt. Ford Motor Company has not approved a slingbelt towing procedure. If the vehicle is towed by other means or incorrectly, vehicle damage may occur.

**CAUTION:** If the Freestyle is to be towed from the front using wheel lift equipment, the front wheels must be raised to a height of 12 in (30 cm) ABOVE the rear wheels to prevent damage to the vehicle body.

**CAUTION:** If the Freestyle is equipped with AWD, it is required to tow the vehicle with all wheels off the ground. Use wheel lift equipment and a dolly or a flatbed transport vehicle to prevent damage to the AWD system.

**NOTE:** Safety chains should be attached in the T-hook slots located on the underside of the rocker panels rearward of the front wheels.

**NOTE:** Refer to general towing information on pages 21 through 24 before towing vehicle.

TRANS	MPH/KMH	MILES/KMS
FWD	UNLTD	UNLTD
AWD with Dolly	UNLTD	UNLTD

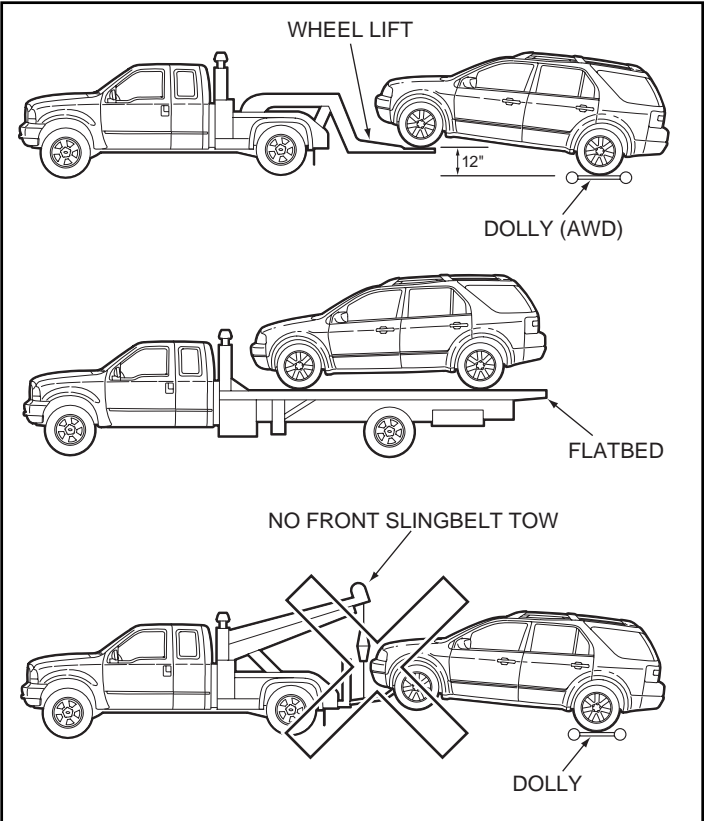

TRANS	MPH/KMH	MILES/KMS
FWD with Dolly	UNLTD	UNLTD
AWD with Dolly	UNLTD	UNLTD

## FREESTYLE

### REAR TOWING CONNECTIONS

**CAUTION:** If the Freestyle is to be towed from the rear using wheel lift equipment, it is required that the front wheels (drive wheels) be placed on a dolly to prevent damage to the transaxle and the vehicle.



**CAUTION:** It is required that the Freestyle be towed with a wheel lift or flatbed equipment. Do not tow with a slingbelt. Ford Motor Company has not approved a slingbelt towing procedure. If the vehicle is towed by other means or incorrectly, vehicle damage may occur.

**CAUTION:** If the Freestyle is to be towed from the rear using wheel lift equipment, the rear wheels must be raised to a height of 12 in (30 cm) ABOVE the front wheels to prevent damage to the vehicle body.

**NOTE:** Safety chains should be attached in the T-hook slots located on the underside of the rocker panels forward of the rear wheels.

**NOTE:** Refer to general towing information on pages 21 through 24 before towing vehicle.

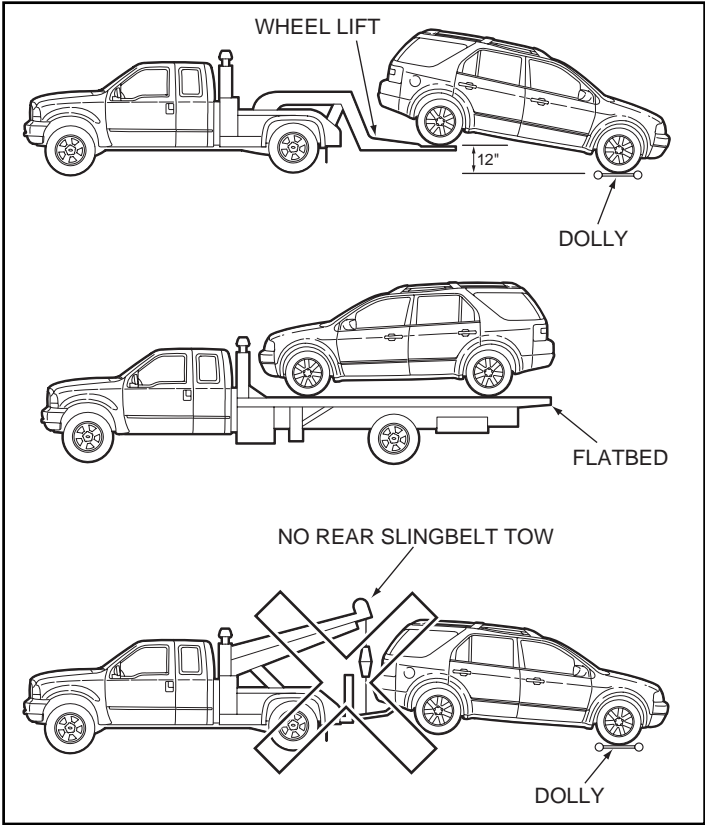

# EDGE, MKX

## FRONT TOWING CONNECTIONS

**CAUTION:** It is recommended that the Edge and MKX be towed with a wheel lift and dollies or flatbed equipment. Do not tow with a slingbelt. Ford Motor Company has not approved a slingbelt towing procedure. If the vehicle is towed by other means or incorrectly, vehicle damage may occur.



**NOTE:** On an AWD vehicle, it is required that the vehicle be towed with a wheel lift and dollies or flatbed equipment with all wheels off the ground to prevent damage to the automatic transmission, AWD systems or vehicle.

**NOTE:** Refer to general towing information on pages 21 through 24 before towing vehicle.

**NOTE:** On a FWD vehicle, it is acceptable to tow the vehicle with the rear wheels on the ground (without dollies).

**NOTE:** For flatbed towing, wrap loading cable with a shop towel to protect fascia from damage.

TRANS	MPH/KMH	MILES/KMS
FWD	UNLTD	UNLTD
AWD with Dolly	UNLTD	UNLTD

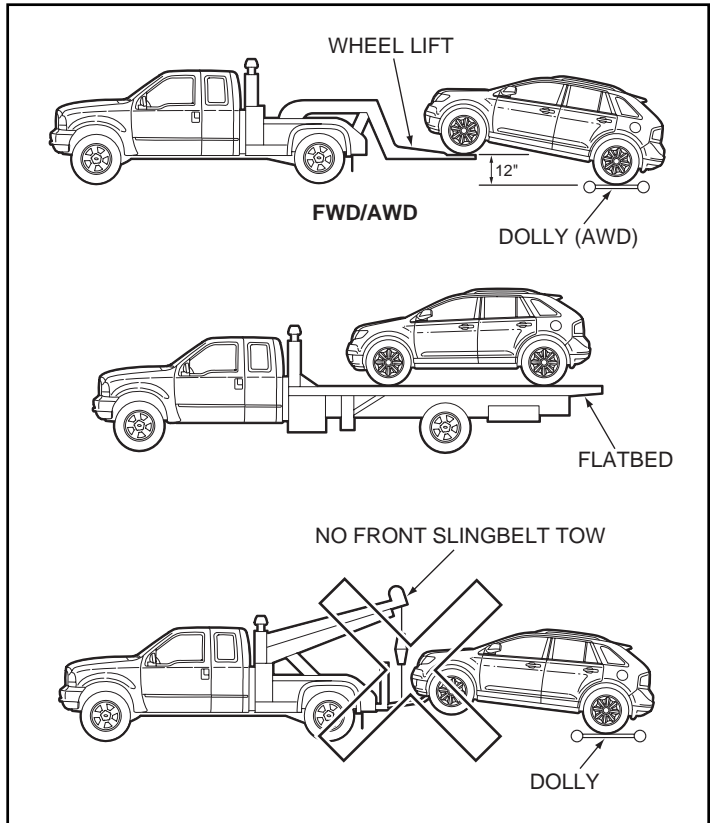

TRANS	MPH/KMH	MILES/KMS
FWD without Dolly	35/56	50/80
FWD/AWD with Dolly	UNLTD	UNLTD

## EDGE, MKX

### REAR TOWING CONNECTIONS

**CAUTION:** It is recommended that the Edge and MKX be towed with a wheel lift and dollies or flatbed equipment. Do not tow with a slingbelt. Ford Motor Company has not approved a slingbelt towing procedure. If the vehicle is towed by other means or incorrectly, vehicle damage may occur.



**NOTE:** On an AWD vehicle, it is required that the vehicle be towed with a wheel lift and dollies or flatbed equipment with all wheels off the ground to prevent damage to the automatic transmission, AWD systems or vehicle.

**NOTE:** Refer to general towing information on pages 21 through 24 before towing vehicle.

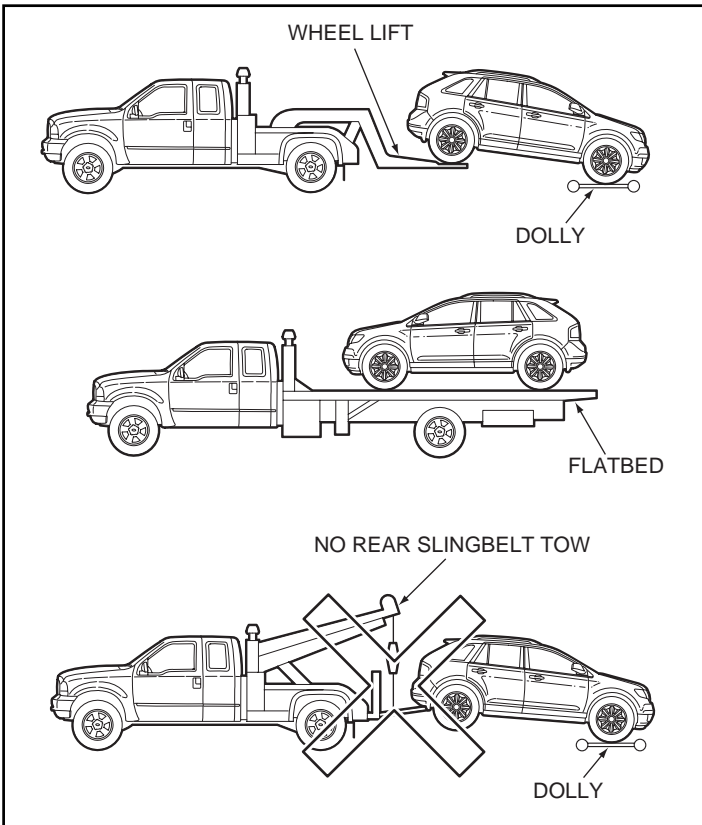

# FREESTAR, MONTEREY

## FRONT AND REAR TOWING CONNECTIONS

**CAUTION:** If the Freestar, Monterey is to be towed from the rear using wheel lift equipment, the front wheels (drive wheels) must be placed on a dolly to prevent damage to the transaxle.



**CAUTION:** It is recommended that the Freestar, Monterey be towed with a wheel lift or flatbed equipment. Do not tow with a slingbelt. Ford Motor Company has not approved a slingbelt towing procedure. If the vehicle is towed by other means or incorrectly, vehicle damage may occur.

**NOTE:** Refer to general towing information on pages 21 through 24 before towing vehicle.

TRANS	MPH/KMH	MILES/KMS
AUTO without Dolly	35/56	50/80
AUTO with Dolly	UNLTD	UNLTD

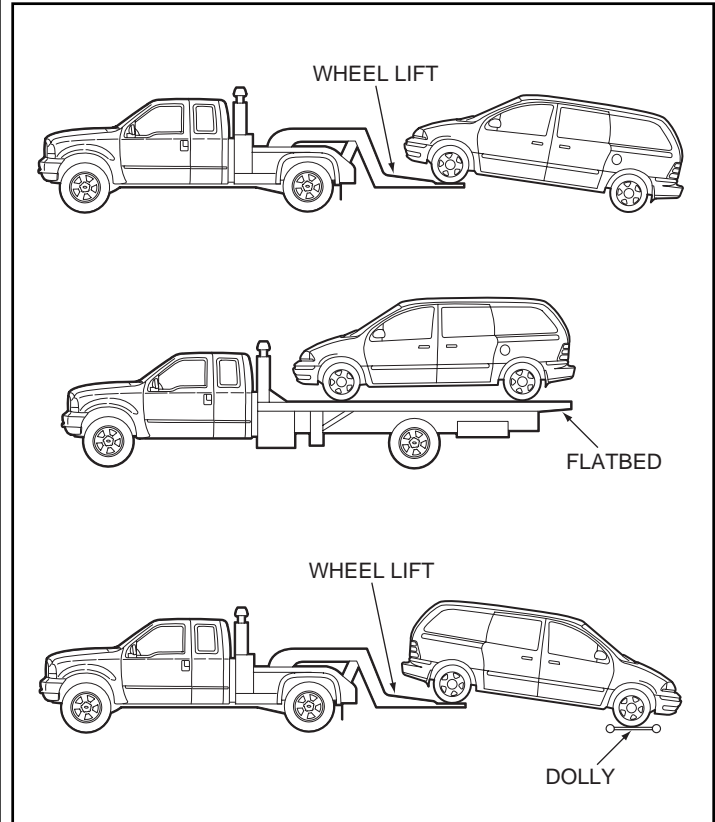

TRANS	MPH/KMH	MILES/KMS
AUTO/4x2 without Dolly	35/56	50/80
AUTO with Dolly	UNLTD	UNLTD

## EXPLORER, MOUNTAINEER, SPORT-TRAC

### FRONT TOWING CONNECTIONS

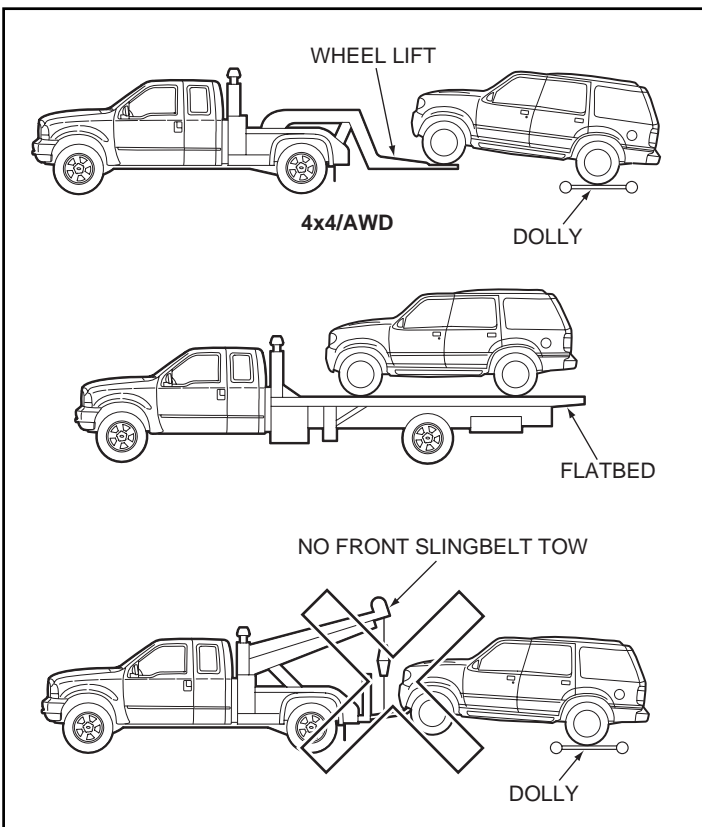

**CAUTION:** It is recommended that the Explorer, Mountaineer and Sport-Trac (4x2, 4x4/AWD) be towed with a wheel lift or flatbed equipment. Do not tow with a slingbelt. Ford Motor Company has not approved a slingbelt towing procedure. If the vehicle is towed by other means or incorrectly, vehicle damage may occur.



**NOTE:** Refer to general towing information on pages 21 through 24 before towing vehicle.

**NOTE:** On a 4x4/AWD vehicle, it is required that the vehicle be towed with a wheel lift or flatbed equipment with all the wheels off the ground.

## EXPLORER, MOUNTAINEER, SPORT-TRAC

### REAR TOWING CONNECTIONS

**CAUTION:** It is recommended that the Explorer, Mountaineer and Sport-Trac (4x2, 4x4) be towed with a wheel lift or flatbed equipment. Do not tow with a slingbelt. Ford Motor Company has not approved a slingbelt towing procedure. If the vehicle is towed by other means or incorrectly, vehicle damage may occur.

**NOTE:** Refer to general towing information on pages 21 through 24 before towing vehicle.

**NOTE:** On a 4x2 vehicle, it is acceptable to tow the vehicle with the front wheels on the ground (without dollies) and the rear wheels off the ground.

**NOTE:** On a 4x4/AWD vehicle, it is required that the vehicle be towed with a wheel lift or flatbed equipment with all the wheels off the ground.



TRANS	MPH/KMH	MILES/KMS
AUTO/4x2 without Dolly	35/56	50/80
AUTO with Dolly	UNLTD	UNLTD

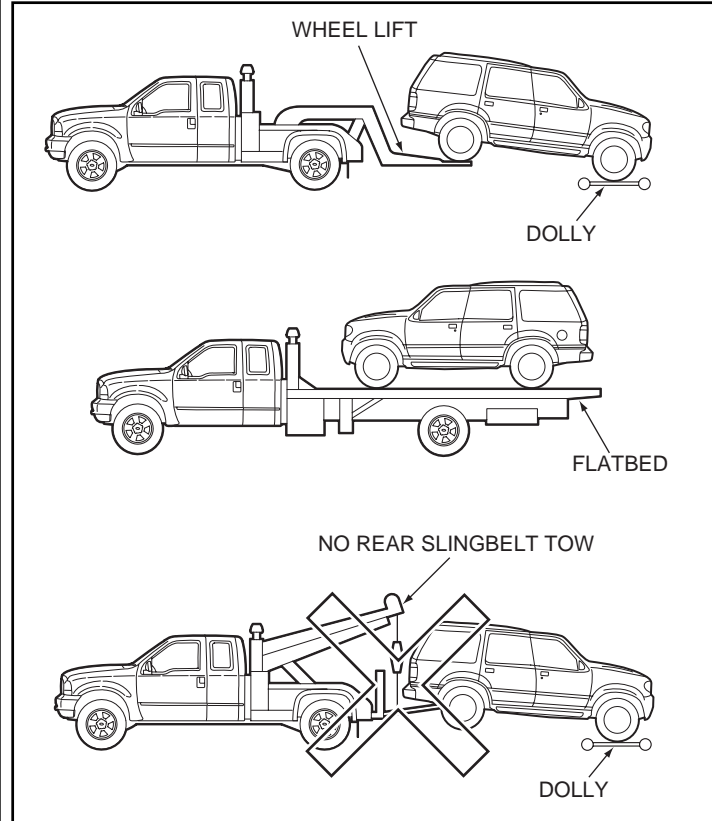



TRANS	MPH/KMH	MILES/KMS
AUTO with Dolly	UNLTD	UNLTD
AUTO without Dolly	35/56	55/80
MANUAL without Dolly	UNLTD	UNLTD

# RANGER

## FRONT TOWING CONNECTIONS

**CAUTION:** It is recommended that the Ranger (4x2, 4x4) be towed with a wheel lift or flatbed equipment. Do not tow with a slingbelt. Ford Motor Company has not approved a slingbelt towing procedure. If the vehicle is towed by other means or incorrectly, vehicle damage may occur.



**CAUTION:** If the Ranger STX is to be towed from the front using wheel lift equipment, the front wheels must be raised to a minimum height of 20 in (51 cm) ABOVE the rear wheels to prevent damage to the front fascia.

**NOTE:** Refer to general towing information on pages 21 through 24 before towing vehicle.

**NOTE:** On all vehicles, it is recommended that the vehicle be towed with a wheel lift and dolly or flatbed equipment with all the wheels off the ground.

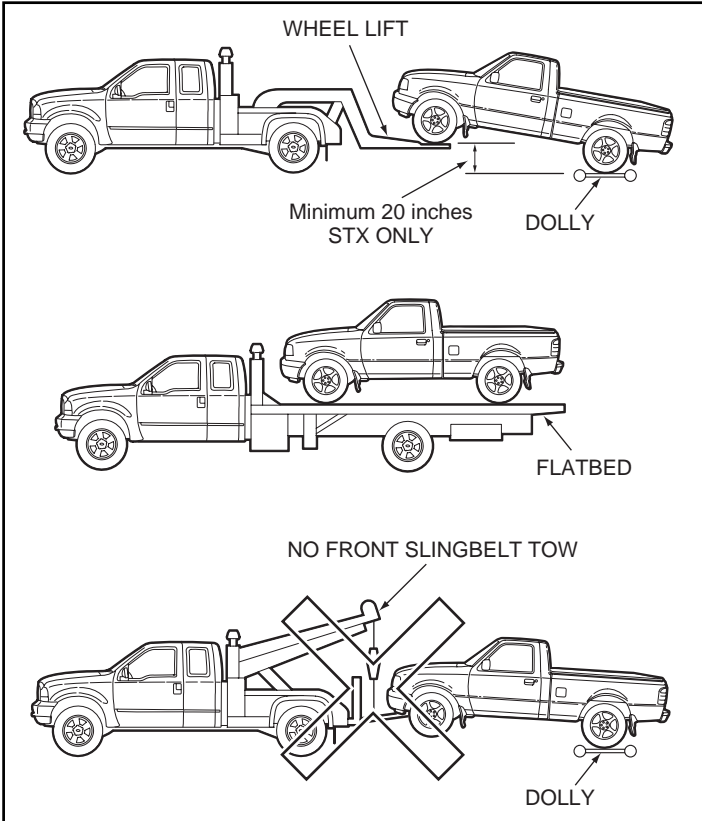

# RANGER

## REAR TOWING CONNECTIONS

**CAUTION:** It is recommended that the Ranger be towed with a wheel lift or flatbed equipment. Do not tow with a slingbelt. Ford Motor Company has not approved a slingbelt towing procedure. If the vehicle is towed by other means or incorrectly, vehicle damage may occur.



**NOTE:** Refer to general towing information on pages 21 through 24 before towing vehicle.

**NOTE:** All STX models must have dollies under the front wheels when towed from the rear to avoid damaging the front fascia. All others (4x2 and 4x4 in 2 HI) can be towed with the front wheels on the ground and the rear wheels off the ground.

TRANS	MPH/KMH	MILES/KMS
AUTO	UNLTD	UNLTD
MANUAL	UNLTD	UNLTD

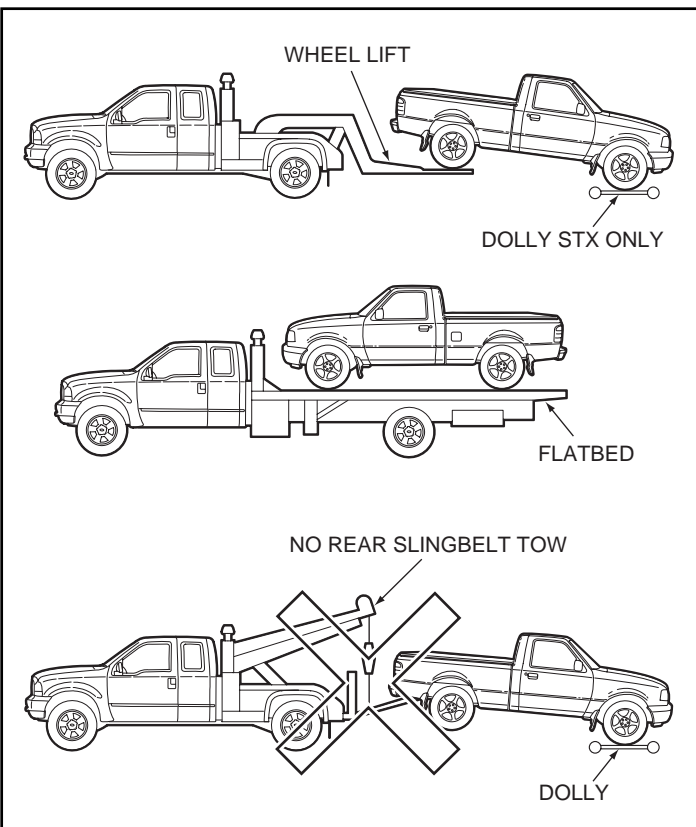

TRANS	MPH/KMH	MILES/KMS
MANUAL/AUTO 2WD	35/56	50/80
4x4 with Dolly	UNLTD	UNLTD

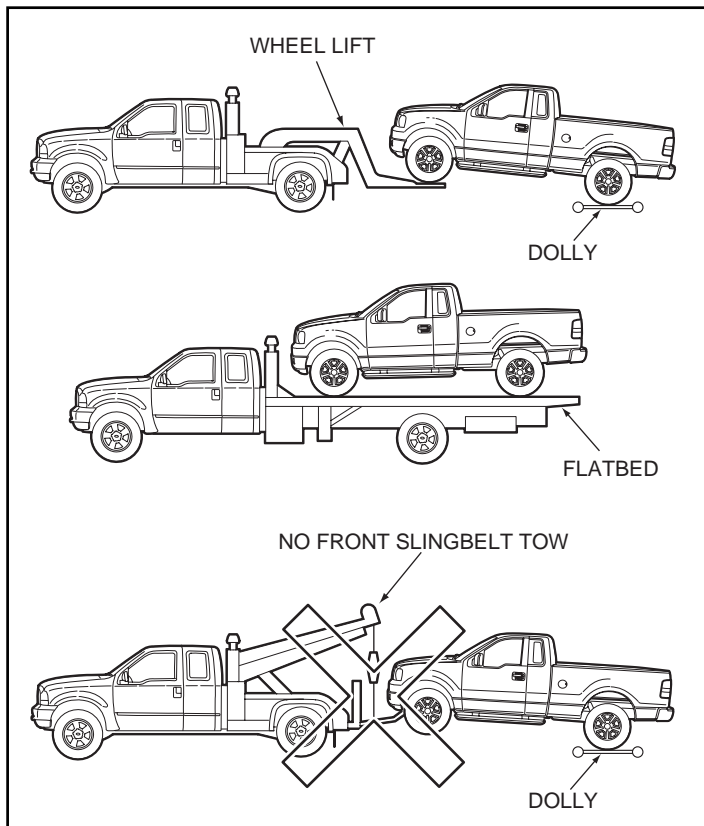

## F-150, NAVIGATOR, EXPEDITION, MARK LT

### FRONT TOWING CONNECTIONS

**CAUTION:** It is recommended that the vehicle be towed with a wheel lift or flatbed equipment. Do not tow with a slingbelt. Ford Motor Company has not approved a slingbelt towing procedure. If the vehicle is towed by other means or incorrectly, vehicle damage may occur.



**CAUTION:** If the vehicle is equipped with air suspension, the air suspension system must be turned to off. For all vehicles except Expedition and Navigator, the control is located behind an access panel beneath the passenger side of the instrument panel.

### For Expedition and Navigator Only

Disable Air Suspension (if equipped). Use the Instrument Cluster Message Center to disable:

1. With ignition in the ON position and doors closed, press the RESET button until all warnings are cleared.
2. Press the SETUP button until AIR SUSPENSION is displayed.
3. Press RESET button to cycle from OFF>ON to >OFF ON. To enable, reverse step 3.

**NOTE:** Refer to general towing information on pages 21 through 24 before towing vehicle.

**NOTE:** On a 4x4 vehicle with a Lever-Operated transfer case in NEUTRAL, it is acceptable to tow the vehicle with the rear wheels on the ground.

## F-150, NAVIGATOR, EXPEDITION, MARK LT

### REAR TOWING CONNECTIONS

#### DO NOT TOW WITH SLINGBELT EQUIPMENT

**CAUTION:** It is recommended that the vehicle be towed with a wheel lift or flatbed equipment. Do not tow with a slingbelt. Ford Motor Company has not approved a slingbelt towing procedure. If the vehicle is towed by other means or incorrectly, vehicle damage may occur.



**CAUTION:** If the vehicle is equipped with air suspension, the air suspension system must be turned to off. For all vehicles except Expedition and Navigator, the control is located behind an access panel beneath the passenger side of the instrument panel.

#### For Expedition and Navigator Only

Disable Air Suspension (if equipped). Use the Instrument Cluster Message Center to disable:

1. With ignition in the ON position and doors closed, press the RESET button until all warnings are cleared.
2. Press the SETUP button until AIR SUSPENSION is displayed.
3. Press RESET button to cycle from OFF>ON to >OFF ON. To enable, reverse step 3.

**CAUTION:** On a 4x4 Control Trac System (Expedition and Navigator), the vehicle must be towed with the wheels on a dolly or flatbed.

**NOTE:** Refer to general towing information on pages 21 through 24 before towing vehicle.

TRANS	MPH/KMH	MILES/KMS
MANUAL/AUTO 2WD	UNLTD	UNLTD
4x4 with Dolly	UNLTD	UNLTD

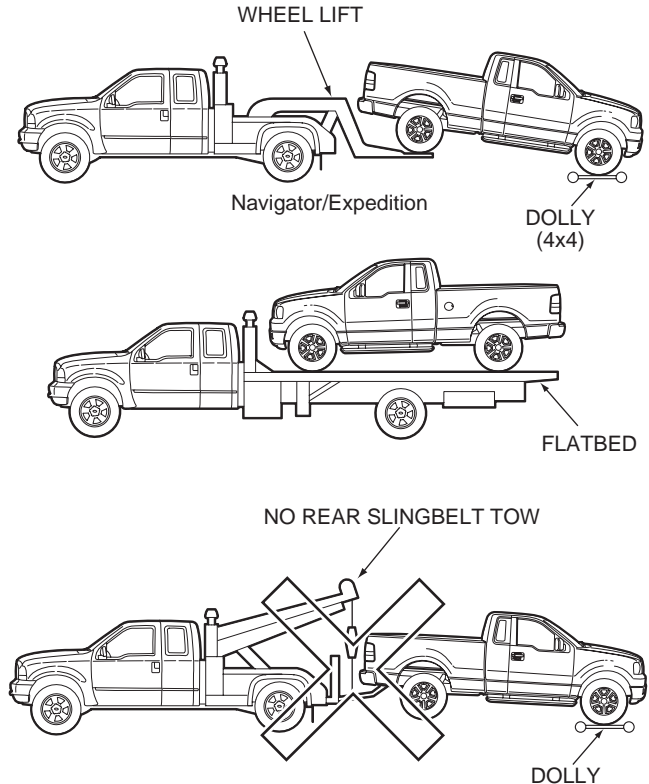

TRANS	MPH/KMH	MILES/KMS
*Auto, 2WD	35/56	50/80
**Auto, 4x4 ESOF with rear wheel dolly	UNLTD	UNLTD
Auto, MSOS	UNLTD	UNLTD
Manual	UNLTD	UNLTD

\*Exceeding speed or mileage may cause auto transmission damage.  
\*\*Towing 4x4 ESOF with rear wheels on ground may cause transmission damage.

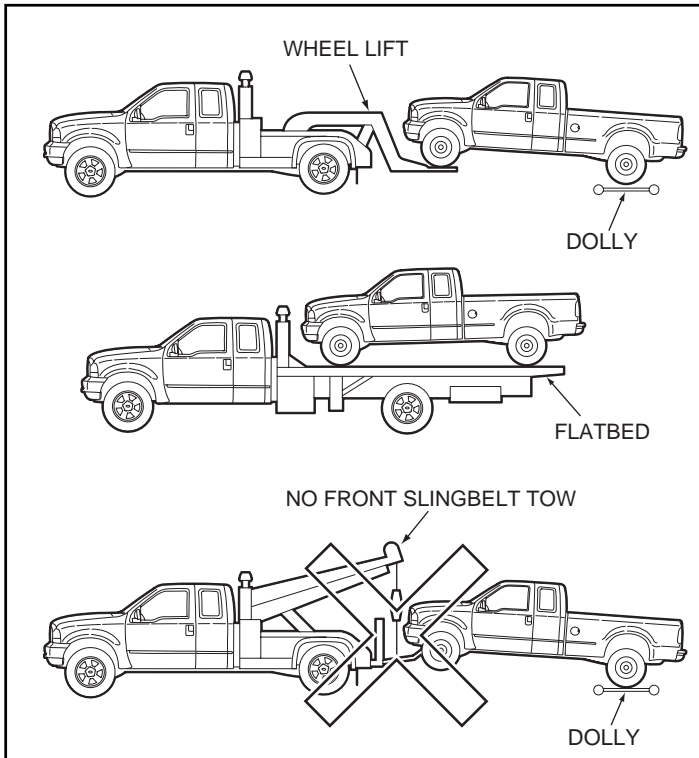

## F-SUPER DUTY (F-250, F-350, F-450, F-550)

### FRONT TOWING CONNECTIONS

**CAUTION: It is recommended that the vehicle be towed with a wheel lift or flatbed equipment. Do not tow with a slingbelt. Ford Motor Company has not approved a slingbelt towing procedure. If the vehicle is towed by other means or incorrectly, vehicle damage may occur.**



**NOTE:** Refer to general towing information on pages 21 through 24 before towing vehicle.

- Insert T-hooks in T-hook slots in the blocker beam slots that are located in the flattened portion of the beam at each end.

**NOTE:** Some F-450 and F-550 vehicles may include or be equipped with aftermarket equipment. These components could be damaged using a wheel lift. Refer to the body builders information for towing instructions.

**NOTE:** On a 4x4 vehicle with Electronic Shift on the Fly (ESOF), it is recommended that the vehicle be towed with a wheel lift and dolly or flatbed equipment with all the wheels off the ground.

**NOTE:** On a 4x4 vehicle with Manual Shift on Stop (MSOS) with the transfer case in NEUTRAL it is acceptable to tow the vehicle with the rear wheels on the ground and the transmission in PARK.

## F-SUPER DUTY (F-250, F-350, F-450, F-550)

### REAR TOWING CONNECTIONS

**CAUTION:** It is recommended that the vehicle be towed with a wheel lift or flatbed equipment. Do not tow with a slingbelt. Ford Motor Company has not approved a slingbelt towing procedure. If the vehicle is towed by other means or incorrectly, vehicle damage may occur.



**NOTE:** Refer to general towing information on pages 21 through 24 before towing vehicle.

- Attach T-hooks in T-hook slots on frame rail.

**NOTE:** For dual rear wheel (DRW) vehicles, it may be necessary to remove the outer rear wheel when using wheel lift equipment.

**NOTE:** Some F-450 and F-550 vehicles may include or be equipped with aftermarket equipment. These components could be damaged using a wheel lift. Refer to the body builder information for towing instructions.

**NOTE:** On a 4x2/4x4 vehicle in 2 HI and the hubs in the AUTO/FREE position, it is acceptable to tow the vehicle with the front wheels on the ground (without dollies) and the rear wheels off the ground.

TRANS	MPH/KMH	MILES/KMS
Auto, 2WD	UNLTD	UNLTD
*Auto, 4x4 ESOF with front hubs free	UNLTD	UNLTD
Manual	UNLTD	UNLTD
*Towing 4x4 ESOF from the rear with the front hubs engaged may cause auto transmission damage.		

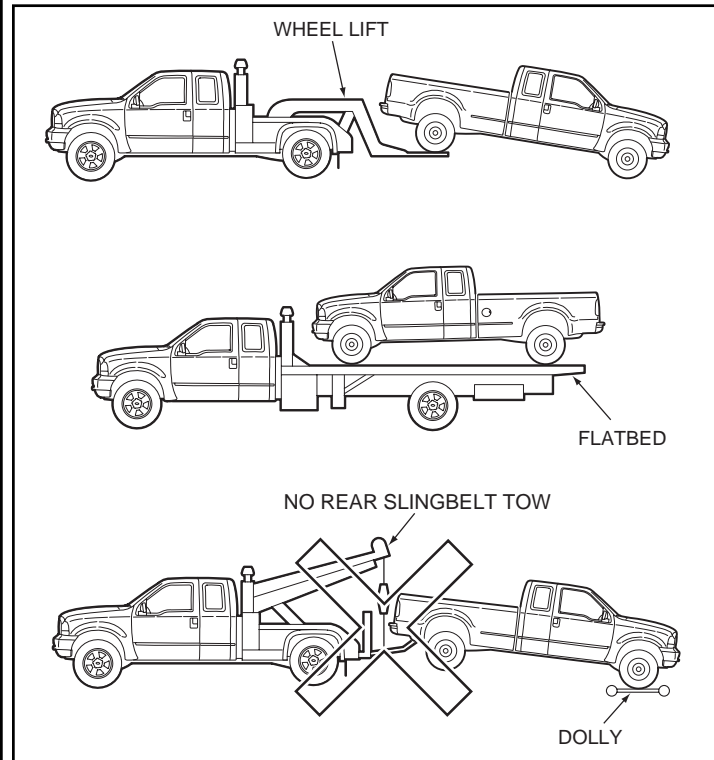

TRANS	MPH/KMH	MILES/KMS
FWD	UNLTD	UNLTD
4x4 with Dolly	UNLTD	UNLTD

**ESCAPE, MARINER, ESCAPE HYBRID, MARINER HYBRID**

**FRONT TOWING CONNECTIONS**

**CAUTION:** It is recommended that the Escape and Mariner (FWD, 4x4) be towed with a wheel lift or flatbed equipment. Do not tow with a slingbelt. Ford Motor Company has not approved a slingbelt towing procedure. If the vehicle is towed by other means or incorrectly, vehicle damage may occur.



**NOTE:** On a FWD vehicle, it is acceptable to tow the vehicle with the rear wheels on the ground and the front wheels off the ground.

**NOTE:** On a 4x4 vehicle, it is required that the vehicle be towed with a wheel lift and dolly or flatbed equipment with all the wheels off the ground.

**NOTE:** Refer to general towing information on pages 21 through 24 before towing vehicle.

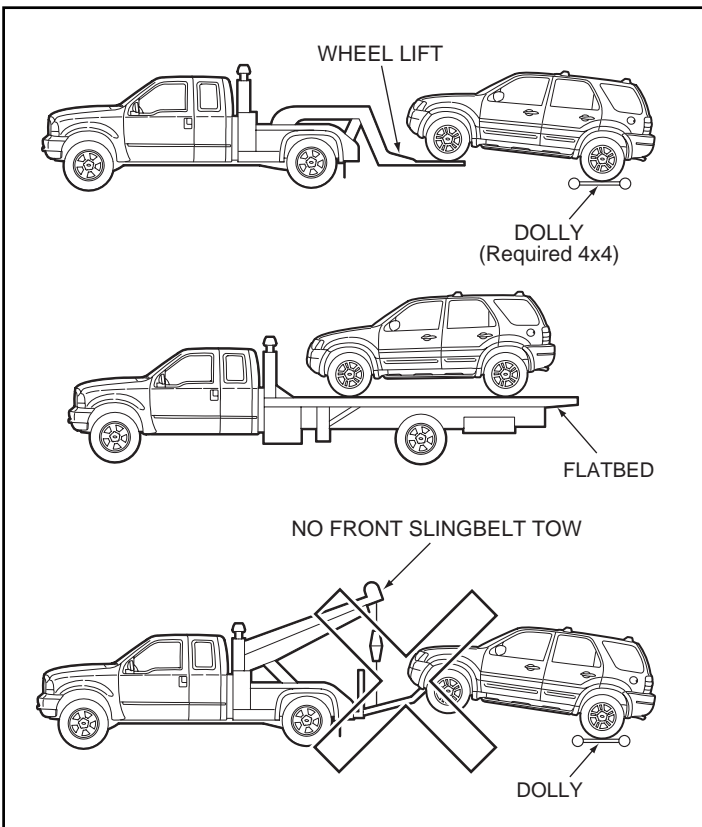

## ESCAPE, MARINER, ESCAPE HYBRID, MARINER HYBRID

### REAR TOWING CONNECTIONS

**CAUTION:** If the Escape and Mariner (FWD, 4x4) is to be towed from the rear using wheel lift equipment, the front wheels (drive wheels) must be placed on a dolly to prevent damage to the transaxle.



**CAUTION:** It is recommended that the Escape and Mariner (FWD, 4x4) be towed with a wheel lift or flatbed equipment. Do not tow with a slingbelt. Ford Motor Company has not approved a slingbelt towing procedure. If the vehicle is towed by other means or incorrectly, vehicle damage may occur.

**NOTE:** Refer to general towing information on pages 21 through 24 before towing vehicle.

TRANS	MPH/KMH	MILES/KMS
AUTO with Dolly	UNLTD	UNLTD

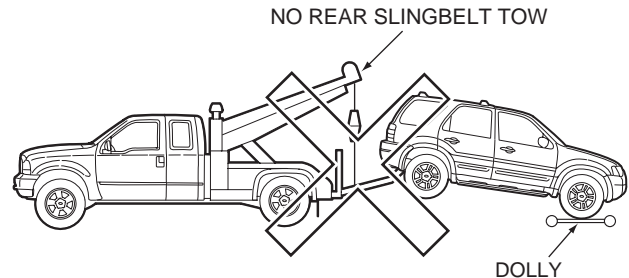
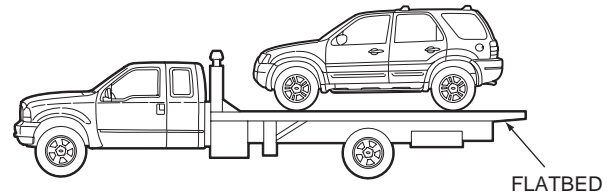
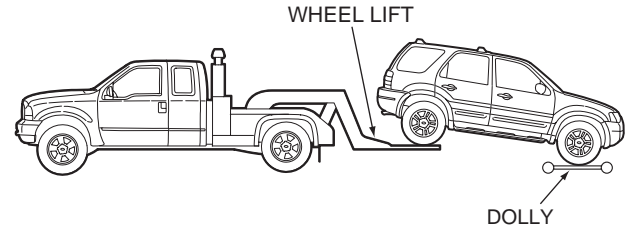



TRANS	MPH/KMH	MILES/KMS
AUTO	35/56	50/80

## E-SERIES, CLUB WAGON, E-150, E-250, E-350, E-450

### FRONT TOWING CONNECTIONS — SLINGBELT

**CAUTION:** If the vehicle is equipped with an air dam and must be towed from the front, it is recommended that the vehicle be towed with a wheel lift or flatbed equipment to prevent damage to the air dam. If the vehicle is towed by other means or incorrectly, vehicle damage may occur.



**CAUTION:** It is recommended that the E-Series vehicles be towed with a wheel lift or flatbed equipment. However, a slingbelt with T-hooks can also be used.

**CAUTION:** When towing E-Series vehicles, spacer blocks must be used with a 4x4 crossbeam.

**NOTE:** Refer to general towing information on pages 21 through 24 before towing vehicle.

- Insert T-hooks in horizontal T-hook slots in frame.
- Place spacer blocks and 4x4 crossbeam behind bumper and air dam and across frame rails. Make sure that spacer blocks are under frame rails.
- Attach safety chains around axle, outboard of coil springs.

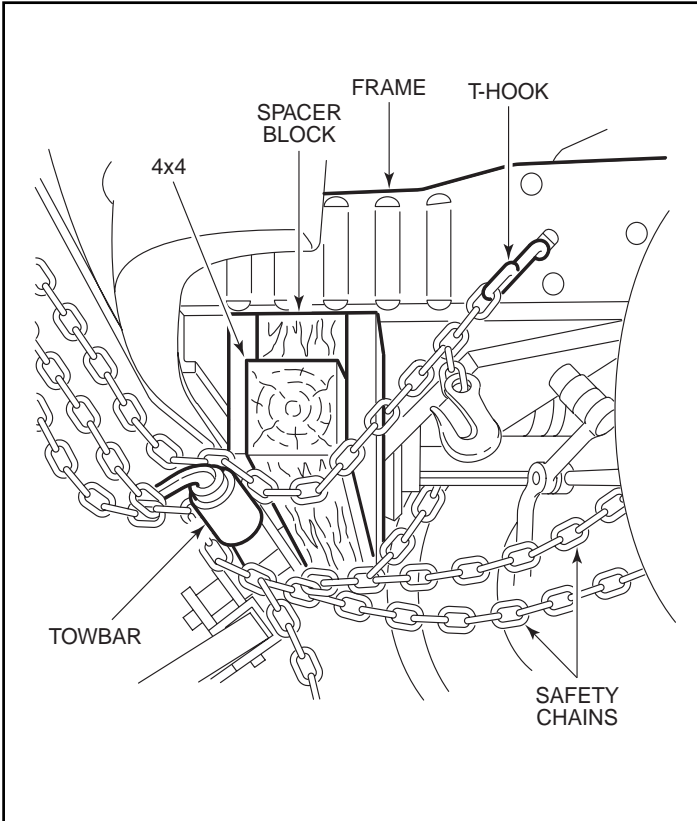

## E-SERIES, CLUB WAGON, E-150, E-250, E-350, E-450

### REAR TOWING CONNECTIONS

**CAUTION:** It is recommended that E-Series vehicles be towed with a wheel lift or flatbed equipment. However, a slingbelt with T-hooks can also be used. If the vehicle is towed by other means or incorrectly, vehicle damage may occur.



**NOTE:** Refer to general towing information on pages 21 through 24 before towing vehicle.

- Attach T-hooks in T-hook slots on frame rail, inside the leaf spring.
- Route chains below spring shackles, on the right side route chain above tail pipe.
- Place towbar under rear bumper, missing spare tire.
- Attach safety chain around rear axle. Route chain between axle and parking brake cable on RH side.

TRANS	MPH/KMH	MILES/KMS
AUTO	UNLTD	UNLTD

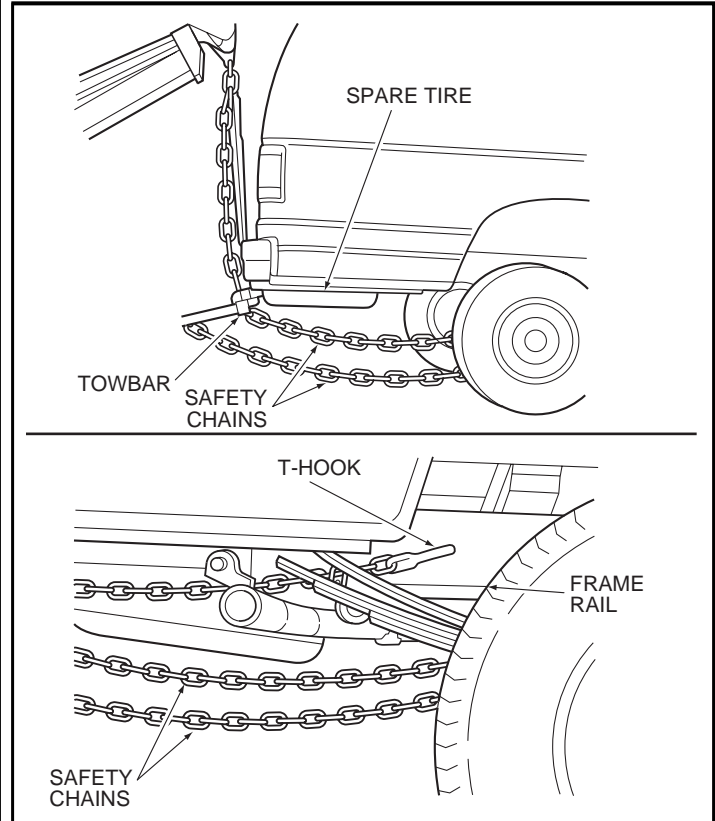

TRANS

MPH/KMH

MILES/KMS

AUTO

35/56

50/80

## E-SERIES H2 ICE

### FRONT TOWING CONNECTIONS

**CAUTION:** It is recommended that the vehicle be towed using wheel lift equipment only. If the vehicle is towed by any other means or incorrectly, vehicle damage may occur.



**CAUTION:** The driveshaft must be removed before the vehicle is towed to prevent damage to the drivetrain components. New bolts must be used when reinstalling the driveshaft.

**NOTE:** Refer to general towing information on pages 21 through 24 before towing vehicle.

- Attach the T-hooks to the T-hook slots in the frame just behind the front bumper, then wrap the chains under the tow bar and attach to the hooks on the front of the tow bar.
- Attach safety chains to the front axle inboard of the stabilizer bar connection.

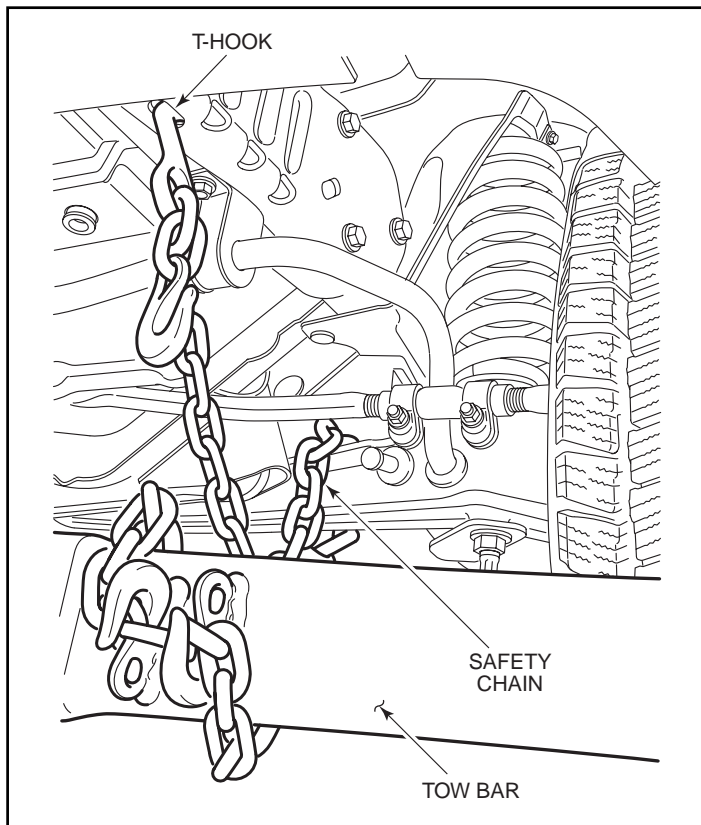

## E-SERIES H2 ICE

### REAR TOWING CONNECTIONS

**CAUTION: It is recommended that the vehicle be lifted using frame fork equipment only. If the vehicle is towed by any other means or incorrectly, vehicle damage may result.**



**NOTE:** Refer to general towing information on pages 21 through 24 before towing vehicle.

- Frame lift forks must not be placed under the hydrogen tank support brackets.
- Remove all slack from the chains, then attach hooks to the inboard side of the frame just forward of the rear bumper and adjacent to the rear leaf spring hangers.
- Attach safety chains as required.

TRANS	MPH/KMH	MILES/KMS
AUTO	UNLTD	UNLTD

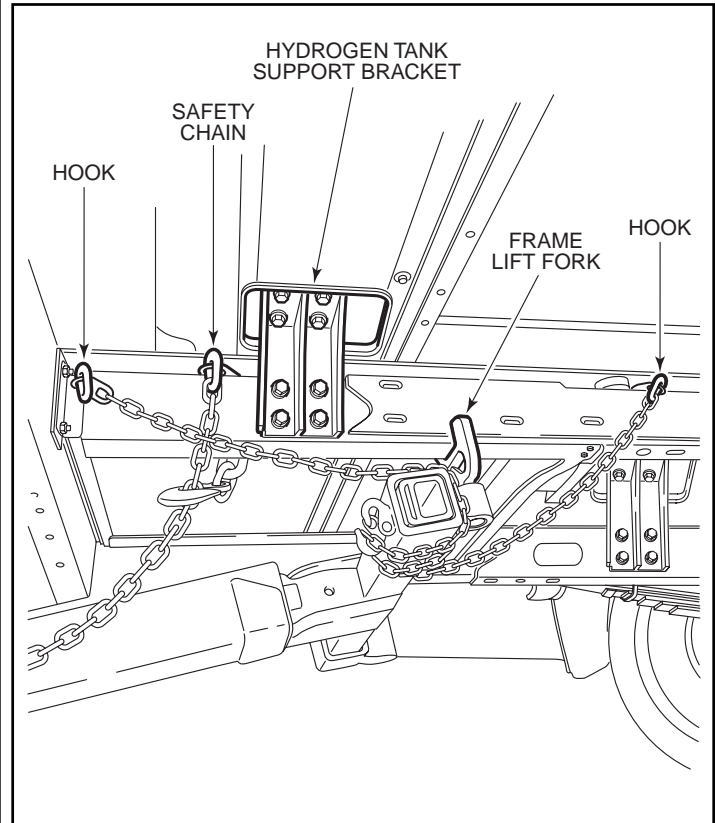

## 2007 FORD SERVICE INFORMATION

With our 2007 Service Information, you can repair Ford, Lincoln and Mercury Cars and Light Trucks in an expert manner and ensure customer satisfaction. The low cost of this information is an investment in the growth of your business.

### WORKSHOP MANUALS

Now available on DVD-ROM, Workshop Manuals provide complete maintenance and repair procedures. Both Car and Truck Workshop Manuals cover Body, Chassis, Electrical, Powertrain, Pre-Delivery and Emissions. A “must” to do the job right the first time.

### WIRING DIAGRAMS

Provide schematics of all electrical components and identify each wire to its proper function.

### ONLINE VIEWING

Go to [www.motorcraft.com](http://www.motorcraft.com), then click on **TECHNICAL RESOURCES** and then on **Quick Guides** to view past model year Wrecker Towing Manuals.

### PUBLICATIONS ORDERING INFORMATION

To obtain information about ordering additional copies of this publication or to order any other Ford or Lincoln/Mercury publication call 1-800-782-4326, go online to [www.helminc.com](http://www.helminc.com) or write to: Ford Publications, care of Helm Inc., P.O. Box 07150, Detroit, MI 48207.